

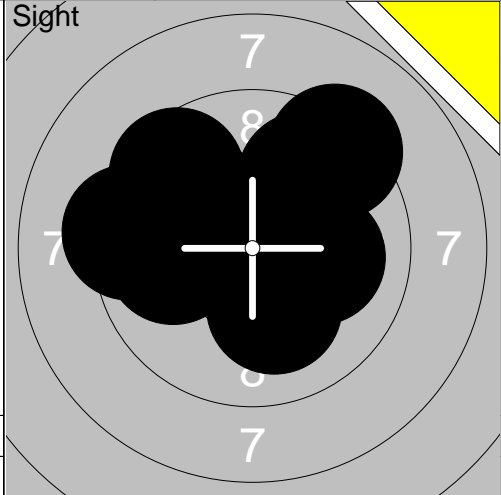

1:	8.5	←
2:	9.8	↖
3:	10.1	→
4:	7.6	←
5:	9.2	↗
6:	9.9	↙
7:	9.0	↗
8:	10.1	←
9:	*10.2	→
10:	9.9	↙
Series		90.0
Total		0.0

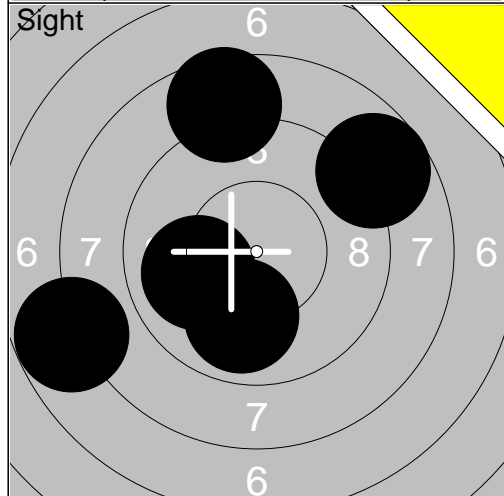

11:	9.3	←
12:	9.9	←
13:	9.6	↖
14:	9.8	↗
15:	10.1	→
16:	9.6	↗
17:	9.9	↗
18:	10.1	↙
19:	9.3	↗
20:	*10.5	↗
Series		93.0
Total		0.0



21:	7.8	←
22:	10.0	←
23:	8.6	↑
24:	9.9	↙
25:	8.7	↗
Series		42.0
Total		0.0

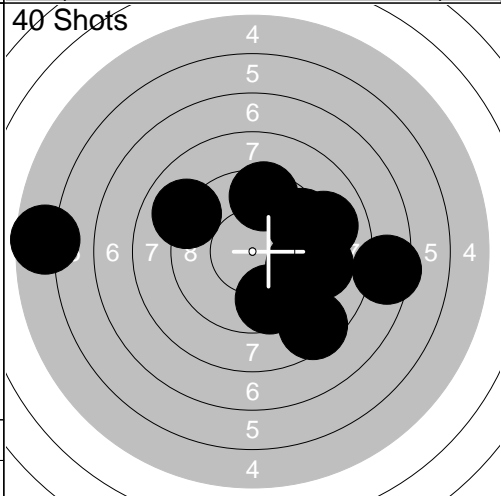

1:	9.0	↖
2:	9.0	→
3:	9.2	→
4:	5.6	←
5:	9.5	↑
6:	9.6	↙
7:	9.7	→
8:	8.5	↙
9:	9.5	↗
10:	7.5	→
Series		83.0
Total		83.0

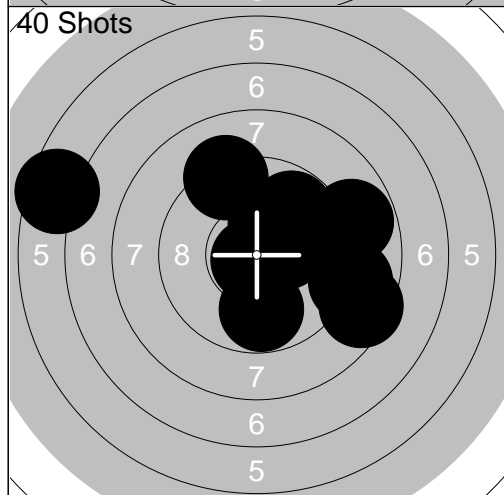

11:	9.8	↗
12:	*10.8	↙
13:	8.5	→
14:	*10.3	→
15:	9.2	↗
16:	8.9	→
17:	6.5	←
18:	8.8	→
19:	9.8	↙
20:	*10.2	↗
Series		87.0
Total		170.0

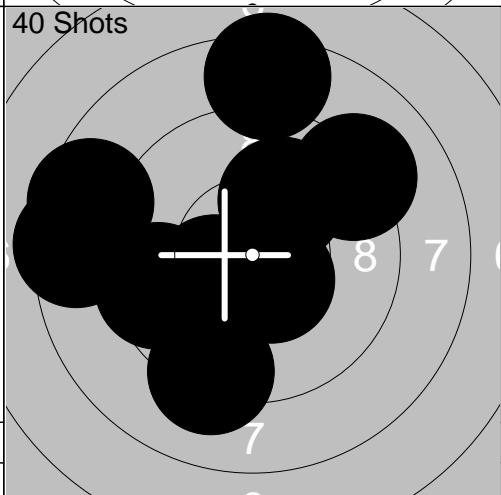

21:	10.1	↗
22:	8.4	↑
23:	8.5	←
24:	9.1	↗
25:	8.5	←
26:	*10.3	↙
27:	9.2	↙
28:	*10.5	↙
29:	*10.3	↙
30:	9.5	←
Series		91.0
Total		261.0

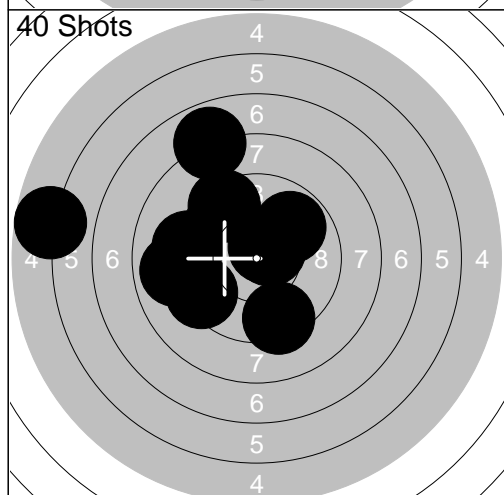

31:	9.3	←
32:	7.9	↗
33:	9.8	↗
34:	*10.6	↗
35:	9.4	↙
36:	*10.6	↗
37:	5.7	←
38:	9.4	↗
39:	9.2	←
40:	8.9	←
Series		85.0
Total		346.0

Relay	Lane	Johanna Nilsson			
10m		Ramselefors		Jun	Vb
26-01-2013		Föbunds mästerskap 2013		Ramselefors SKF	
Sight		1: 8.2 ↖	Sight		11: 9.6 ↗
		2: 8.9 ↗			12: 10.0 ↘
		3: 7.5 →			13: 8.1 ↖
		4: 8.1 ↖			14: 9.3 ↗
		5: 9.7 ↗			15: 9.4 ↗
		6: 8.0 ↗			16: *10.7 →
		7: 8.6 ↗			17: 10.0 ↘
		8: 7.5 ↗			18: 9.3 ↘
		9: 9.5 ↖			19: 9.2 ↖
		10: 9.1 ↖			20: 9.3 ↖
		Series 81.0			Series 92.0
		Total 0.0			Total 0.0
Sight		21: 8.9 →	Sight		31: 9.7 ↗
		22: 9.7 ↘			32: 10.0 ↗
		23: 9.5 →			33: 10.0 ↗
		24: *10.4 →			34: 9.9 ↘
		25: 9.8 ↗			35: 9.3 ↘
		26: 7.4 ↘			36: 9.6 ↗
		27: 9.6 ↘			37: *10.2 ↗
		28: 10.1 ↗			38: *10.6 →
		29: 9.6 ↘			39: 7.3 ↖
		30: 9.7 →			40: *10.5 →
		Series 89.0			Series 93.0
		Total 0.0			Total 0.0
Sight		41: 9.2 ↖	40 Shots		1: 8.4 ↘
		42: *10.2 ↖			2: 9.6 ↘
		43: 9.6 ↖			3: 9.7 ↖
		44: 9.4 →			4: 9.8 ↘
		45: 9.2 ↘			5: 9.1 ↘
		46: 9.6 →			6: 9.2 ↖
		47: 9.0 ↘			7: 8.8 ↗
		48: *10.2 ↘			8: *10.6 ↗
		49: 9.2 ↖			9: 8.8 ↖
		50: *10.3 ↘			10: 9.8 ↗
		Series 93.0			Series 88.0
		Total 0.0			Total 88.0
40 Shots		11: 10.1 ↘	40 Shots		21: 9.5 ↖
		12: *10.4 →			22: 10.0 ↘
		13: *10.5 ↗			23: 9.0 →
		14: 8.9 →			24: *10.8 ↗
		15: 9.7 →			25: 9.0 →
		16: 9.0 →			26: 9.9 ↗
		17: *10.2 ↘			27: 10.0 ↗
		18: 9.6 ↖			28: 9.8 ↗
		19: 7.9 ↖			29: 10.1 ↗
		20: 9.7 ↗			30: 8.7 ↗
		Series 91.0			Series 93.0
		Total 179.0			Total 272.0
40 Shots		31: 8.9 ↗			
		32: 9.9 ↗			
		33: 9.0 →			
		34: 8.1 ↗			
		35: 9.9 ↖			
		36: 9.0 ↗			
		37: 9.0 →			
		38: *10.3 ↖			
		39: 9.6 ↘			
		40: 10.0 ↗			
		Series 90.0			
		Total 362.0			

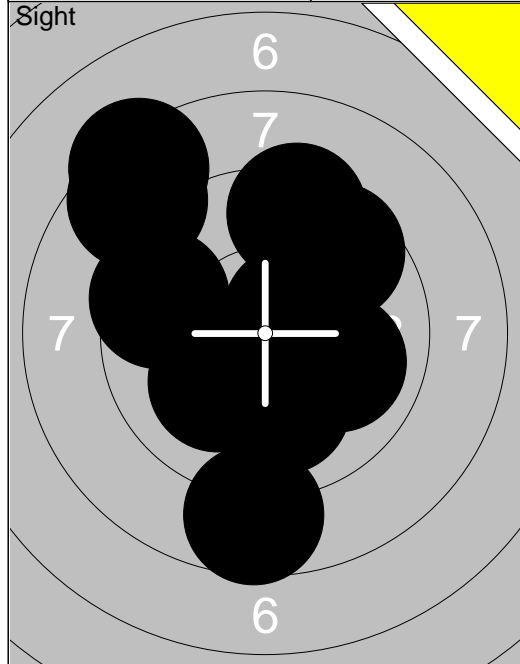

1:	8.6	↓
2:	8.6	↖
3:	9.4	↑
4:	10.1	↙
5:	10.0	→
6:	*10.5	↗
7:	8.3	↗
8:	9.5	←
9:	10.0	↓
10:	9.6	↗
Series		91.0
Total		0.0

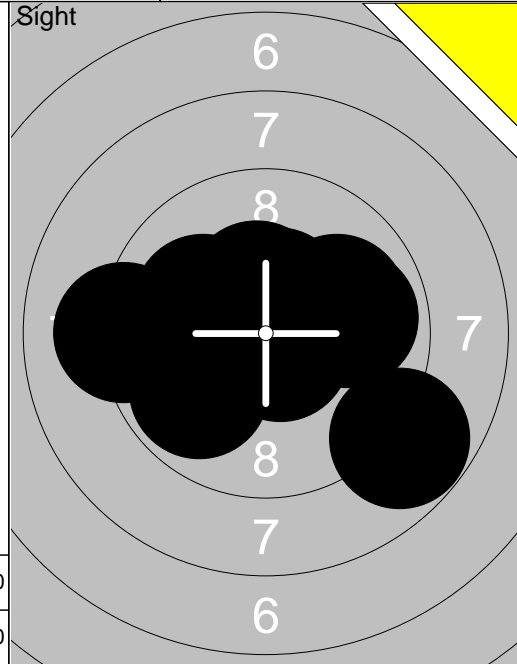

11:	8.8	↘
12:	9.1	←
13:	*10.6	↘
14:	9.9	↙
15:	10.0	↗
16:	*10.5	↑
17:	*10.4	↑
18:	10.1	↖
19:	9.9	↗
Series		85.0
Total		0.0

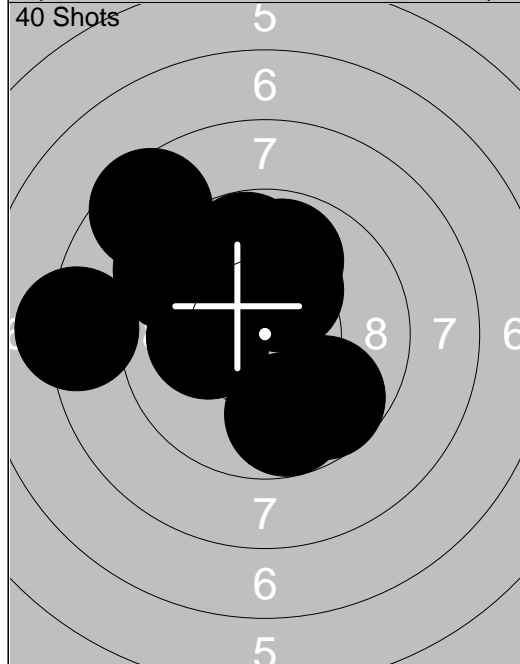

1:	10.1	←
2:	9.9	↑
3:	9.4	↖
4:	8.5	↗
5:	9.7	↘
6:	8.2	←
7:	9.8	↓
8:	*10.2	↑
9:	*10.3	↗
10:	9.8	↑
Series		91.0
Total		91.0

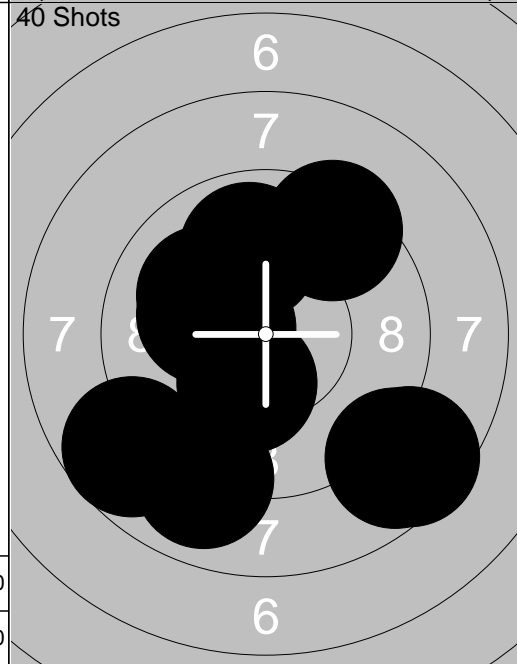

11:	8.7	↘
12:	*10.4	←
13:	8.7	↙
14:	*10.2	←
15:	9.4	↗
16:	8.5	↘
17:	8.9	↓
18:	9.9	↑
19:	*10.3	↘
20:	10.1	↖
Series		90.0
Total		181.0

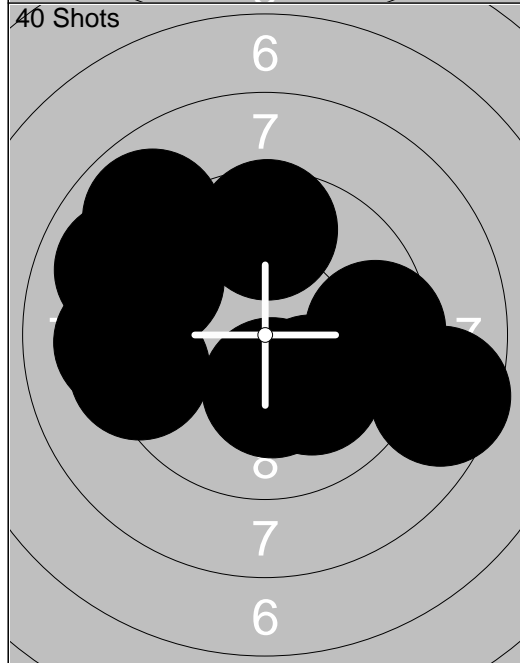

21:	9.5	→
22:	9.6	↑
23:	8.9	↖
24:	9.4	↖
25:	10.1	↘
26:	*10.3	↓
27:	8.6	→
28:	9.3	←
29:	9.0	↖
30:	9.1	←
Series		90.0
Total		271.0

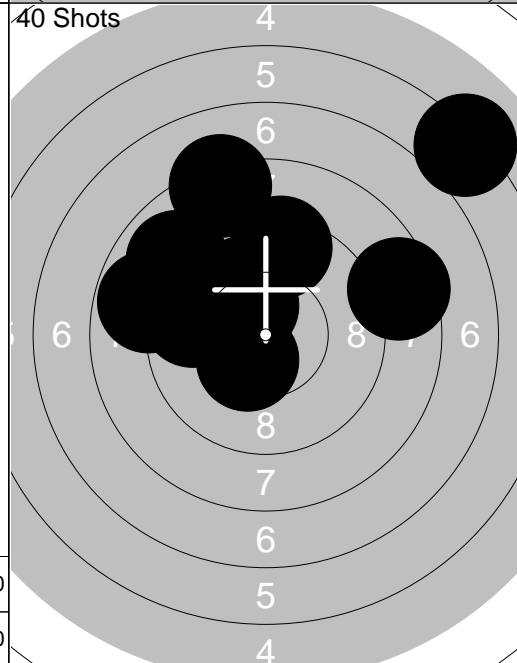



31:	*10.3	↖
32:	*10.4	↙
33:	8.2	↑
34:	8.5	→
35:	8.9	↖
36:	8.8	←
37:	6.1	↗
38:	10.0	↑
39:	9.6	←
40:	9.4	↑
Series		86.0
Total		357.0

<p>Sight</p>	<p>1: 9.6 ↘ 2: 9.6 ↘ 3: *10.3 ↙ 4: 9.6 ← 5: 10.0 ↗ 6: 8.3 ← 7: 9.4 ← 8: 9.5 ↘ 9: 10.1 ↗ 10: 9.9 ←</p>	<p>Sight</p>	<p>11: 9.5 ↙ 12: 8.7 ↗ 13: *10.5 ← 14: *10.3 ↘ 15: 8.7 → 16: *10.4 ↘</p>
<p>Series 92.0</p>		<p>Series 55.0</p>	
<p>Total 0.0</p>		<p>Total 0.0</p>	

<p>40 Shots</p>	<p>1: 9.9 → 2: 9.3 → 3: 10.0 ↗ 4: *10.3 ↗ 5: *10.3 ↘ 6: 9.5 ↘ 7: 9.5 ← 8: 10.0 ↑ 9: 9.2 ↗ 10: 10.0 ←</p>	<p>40 Shots</p>	<p>11: *10.5 ↘ 12: *10.7 ← 13: 9.7 ↘ 14: 10.0 ← 15: *10.6 ↙ 16: *10.4 ↗ 17: 9.1 ↗ 18: 10.0 ↙ 19: 9.1 ↑ 20: *10.9 ↗</p>
<p>Series 95.0</p>		<p>Series 97.0</p>	
<p>Total 95.0</p>		<p>Total 192.0</p>	

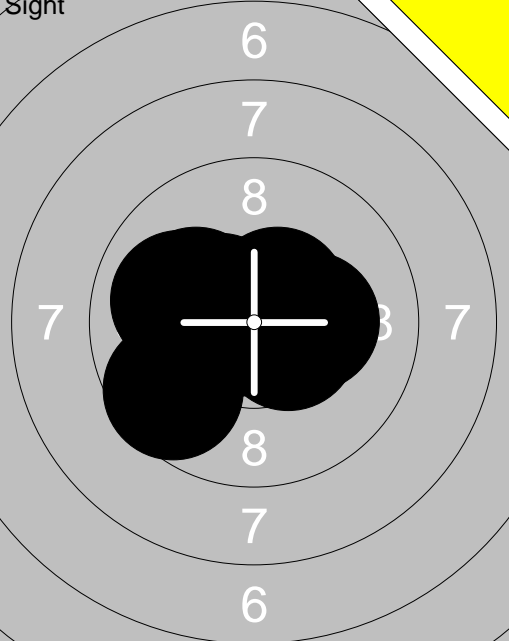
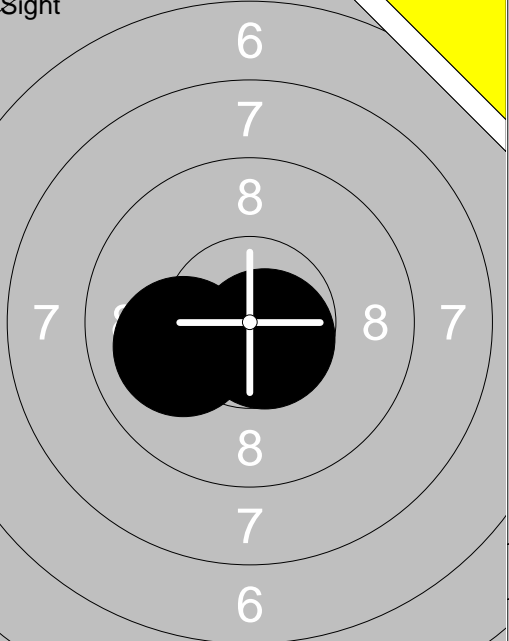
<p>40 Shots</p>	<p>21: *10.3 ← 22: 9.9 ↗ 23: 9.9 ↑ 24: *10.8 ↘ 25: 10.0 ← 26: *10.4 ↑ 27: 9.5 ↗ 28: 9.9 ← 29: 10.0 ↘ 30: *10.4 →</p>	<p>40 Shots</p>	<p>31: 9.9 ↗ 32: *10.4 ↘ 33: 9.5 → 34: 9.8 ↑ 35: 10.0 ↘ 36: *10.4 ↗ 37: 9.3 ↘ 38: 9.0 ↙ 39: 9.5 ↗ 40: 9.7 ↑</p>
<p>Series 96.0</p>		<p>Series 93.0</p>	
<p>Total 288.0</p>		<p>Total 381.0</p>	

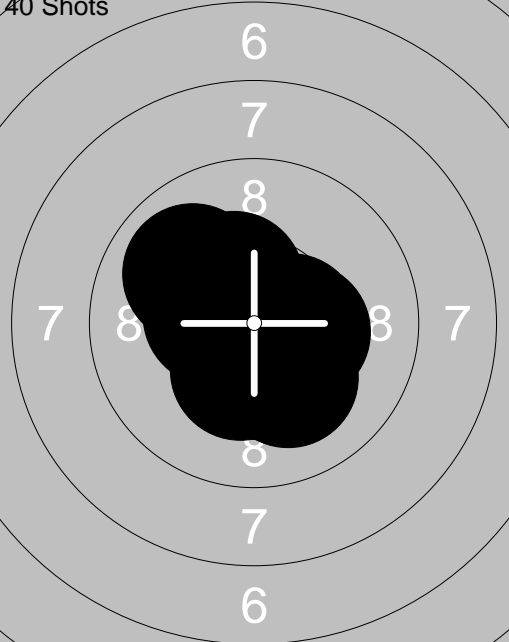
<p>Sight</p> 	<p>Sight</p> 	
<p>1: *10.5 →</p> <p>2: *10.4 ↖</p> <p>3: 10.1 ↖</p> <p>4: *10.9 ↖</p> <p>5: 10.0 ↖</p> <p>6: *10.5 ↗</p> <p>7: *10.2 →</p> <p>8: *10.7 ←</p> <p>9: *10.6 ↗</p> <p>10: 9.6 ↖</p>	<p>11: 10.0 ←</p> <p>12: *10.7 ↘</p>	
<p>Series 99.0</p> <p>Total 0.0</p>	<p>Series 20.0</p> <p>Total 0.0</p>	

<p>40 Shots</p> 	<p>40 Shots</p> 	
<p>1: *10.3 ↓</p> <p>2: *10.5 ↓</p> <p>3: *10.6 ↗</p> <p>4: 10.1 ↓</p> <p>5: *10.4 →</p> <p>6: 10.0 ↗</p> <p>7: *10.5 →</p> <p>8: *10.3 ↓</p> <p>9: *10.4 ←</p> <p>10: *10.4 ↗</p>	<p>11: 9.9 ←</p> <p>12: *10.8 ↓</p> <p>13: *10.3 ↓</p> <p>14: *10.8 ↓</p> <p>15: *10.9 ↗</p> <p>16: *10.5 ↓</p> <p>17: *10.6 ↑</p> <p>18: 10.0 ↓</p> <p>19: *10.3 →</p> <p>20: 10.1 ↗</p>	
<p>Series 100.0</p> <p>Total 100.0</p>	<p>Series 99.0</p> <p>Total 199.0</p>	

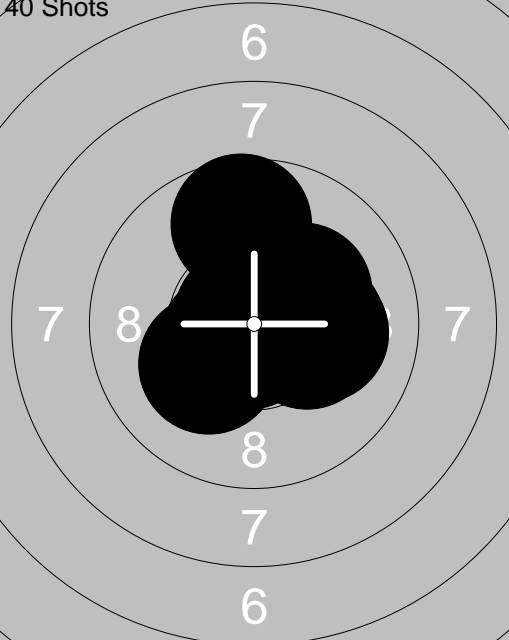
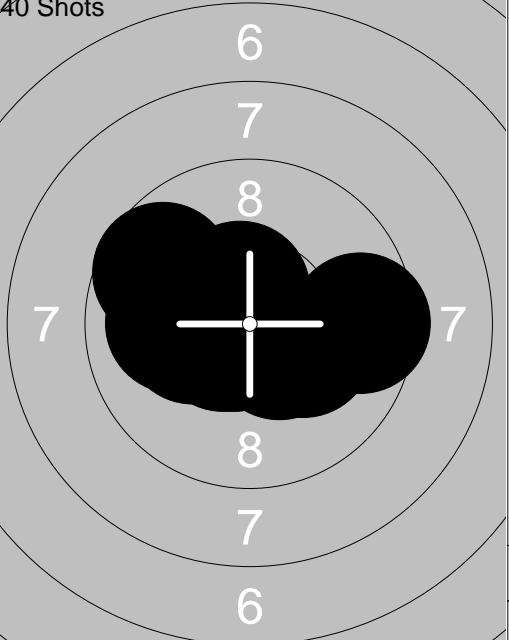
<p>40 Shots</p> 	<p>40 Shots</p> 	
<p>21: *10.2 →</p> <p>22: *10.8 ↖</p> <p>23: *10.7 ↓</p> <p>24: *10.6 ←</p> <p>25: 9.7 ↑</p> <p>26: 10.1 →</p> <p>27: *10.2 ↖</p> <p>28: *10.2 ↗</p> <p>29: *10.6 ↗</p> <p>30: *10.2 →</p>	<p>31: 9.5 →</p> <p>32: *10.2 ←</p> <p>33: *10.2 ↘</p> <p>34: 9.7 ↗</p> <p>35: *10.5 ↓</p> <p>36: *10.5 ↗</p> <p>37: *10.6 ←</p> <p>38: *10.7 ↘</p> <p>39: 10.0 ←</p> <p>40: *10.5 ↖</p>	
<p>Series 99.0</p> <p>Total 298.0</p>	<p>Series 98.0</p> <p>Total 396.0</p>	

<p>Sight</p>	<p>40 Shots</p>	<table style="width:100%; border-collapse: collapse;"> <tr><td>1: 9.9</td><td>↘</td><td>1: *10.7</td><td>←</td></tr> <tr><td>2: 10.1</td><td>↘</td><td>2: 8.0</td><td>↑</td></tr> <tr><td>3: 9.6</td><td>↗</td><td>3: 10.1</td><td>→</td></tr> <tr><td>4: *10.2</td><td>↗</td><td>4: *10.2</td><td>↗</td></tr> <tr><td>5: 7.8</td><td>←</td><td>5: 9.7</td><td>←</td></tr> <tr><td>6: 10.1</td><td>↘</td><td>6: 9.2</td><td>↑</td></tr> <tr><td></td><td></td><td>7: 9.8</td><td>↗</td></tr> <tr><td></td><td></td><td>8: 9.2</td><td>←</td></tr> <tr><td></td><td></td><td>9: 8.6</td><td>↗</td></tr> <tr><td></td><td></td><td>10: 10.0</td><td>↘</td></tr> <tr><td colspan="2">Series 55.0</td><td colspan="2">Series 92.0</td></tr> <tr><td colspan="2">Total 0.0</td><td colspan="2">Total 92.0</td></tr> </table>	1: 9.9	↘	1: *10.7	←	2: 10.1	↘	2: 8.0	↑	3: 9.6	↗	3: 10.1	→	4: *10.2	↗	4: *10.2	↗	5: 7.8	←	5: 9.7	←	6: 10.1	↘	6: 9.2	↑			7: 9.8	↗			8: 9.2	←			9: 8.6	↗			10: 10.0	↘	Series 55.0		Series 92.0		Total 0.0		Total 92.0	
1: 9.9	↘	1: *10.7	←																																															
2: 10.1	↘	2: 8.0	↑																																															
3: 9.6	↗	3: 10.1	→																																															
4: *10.2	↗	4: *10.2	↗																																															
5: 7.8	←	5: 9.7	←																																															
6: 10.1	↘	6: 9.2	↑																																															
		7: 9.8	↗																																															
		8: 9.2	←																																															
		9: 8.6	↗																																															
		10: 10.0	↘																																															
Series 55.0		Series 92.0																																																
Total 0.0		Total 92.0																																																

<p>40 Shots</p>	<p>40 Shots</p>	<table style="width:100%; border-collapse: collapse;"> <tr><td>11: 10.0</td><td>↗</td><td>21: 9.3</td><td>→</td></tr> <tr><td>12: 8.8</td><td>←</td><td>22: 9.3</td><td>←</td></tr> <tr><td>13: 9.8</td><td>←</td><td>23: 9.9</td><td>↘</td></tr> <tr><td>14: 9.0</td><td>←</td><td>24: 9.9</td><td>←</td></tr> <tr><td>15: *10.2</td><td>↘</td><td>25: *10.4</td><td>↘</td></tr> <tr><td>16: 9.3</td><td>→</td><td>26: 9.4</td><td>↗</td></tr> <tr><td>17: 8.7</td><td>→</td><td>27: *10.6</td><td>↗</td></tr> <tr><td>18: 9.6</td><td>←</td><td>28: 9.7</td><td>←</td></tr> <tr><td>19: 9.2</td><td>↗</td><td>29: 9.7</td><td>↘</td></tr> <tr><td>20: 9.5</td><td>↘</td><td>30: 10.1</td><td>↘</td></tr> <tr><td colspan="2">Series 90.0</td><td colspan="2">Series 93.0</td></tr> <tr><td colspan="2">Total 182.0</td><td colspan="2">Total 275.0</td></tr> </table>	11: 10.0	↗	21: 9.3	→	12: 8.8	←	22: 9.3	←	13: 9.8	←	23: 9.9	↘	14: 9.0	←	24: 9.9	←	15: *10.2	↘	25: *10.4	↘	16: 9.3	→	26: 9.4	↗	17: 8.7	→	27: *10.6	↗	18: 9.6	←	28: 9.7	←	19: 9.2	↗	29: 9.7	↘	20: 9.5	↘	30: 10.1	↘	Series 90.0		Series 93.0		Total 182.0		Total 275.0	
11: 10.0	↗	21: 9.3	→																																															
12: 8.8	←	22: 9.3	←																																															
13: 9.8	←	23: 9.9	↘																																															
14: 9.0	←	24: 9.9	←																																															
15: *10.2	↘	25: *10.4	↘																																															
16: 9.3	→	26: 9.4	↗																																															
17: 8.7	→	27: *10.6	↗																																															
18: 9.6	←	28: 9.7	←																																															
19: 9.2	↗	29: 9.7	↘																																															
20: 9.5	↘	30: 10.1	↘																																															
Series 90.0		Series 93.0																																																
Total 182.0		Total 275.0																																																

<p>40 Shots</p>	<p>40 Shots</p>	<table style="width:100%; border-collapse: collapse;"> <tr><td>31: 8.2</td><td>←</td><td></td><td></td></tr> <tr><td>32: *10.4</td><td>↘</td><td></td><td></td></tr> <tr><td>33: *10.5</td><td>↗</td><td></td><td></td></tr> <tr><td>34: *10.3</td><td>↗</td><td></td><td></td></tr> <tr><td>35: 9.7</td><td>↑</td><td></td><td></td></tr> <tr><td>36: 9.4</td><td>←</td><td></td><td></td></tr> <tr><td>37: *10.7</td><td>←</td><td></td><td></td></tr> <tr><td>38: 9.9</td><td>←</td><td></td><td></td></tr> <tr><td>39: 10.0</td><td>←</td><td></td><td></td></tr> <tr><td>40: 9.5</td><td>↗</td><td></td><td></td></tr> <tr><td colspan="2">Series 94.0</td><td colspan="2"></td></tr> <tr><td colspan="2">Total 369.0</td><td colspan="2"></td></tr> </table>	31: 8.2	←			32: *10.4	↘			33: *10.5	↗			34: *10.3	↗			35: 9.7	↑			36: 9.4	←			37: *10.7	←			38: 9.9	←			39: 10.0	←			40: 9.5	↗			Series 94.0				Total 369.0			
31: 8.2	←																																																	
32: *10.4	↘																																																	
33: *10.5	↗																																																	
34: *10.3	↗																																																	
35: 9.7	↑																																																	
36: 9.4	←																																																	
37: *10.7	←																																																	
38: 9.9	←																																																	
39: 10.0	←																																																	
40: 9.5	↗																																																	
Series 94.0																																																		
Total 369.0																																																		

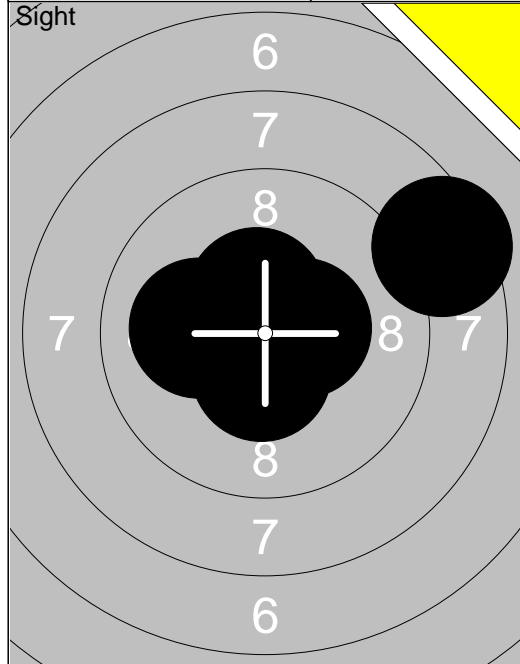

1:	8.4	↗
2:	*10.5	→
3:	*10.5	↓
4:	*10.8	↙
5:	10.1	←
6:	*10.5	↑
Series		58.0
Total		0.0

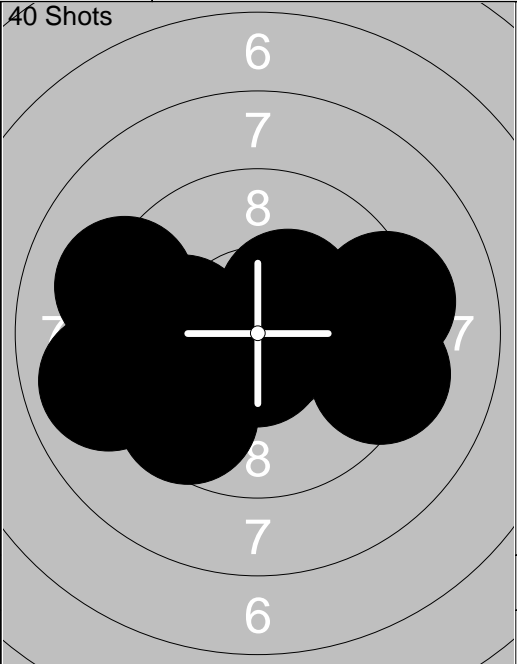

1:	*10.4	↗
2:	9.6	↙
3:	10.0	←
4:	9.3	→
5:	*10.7	↓
6:	9.0	←
7:	9.1	↙
8:	9.3	→
9:	9.5	→
10:	10.0	←
Series		94.0
Total		94.0

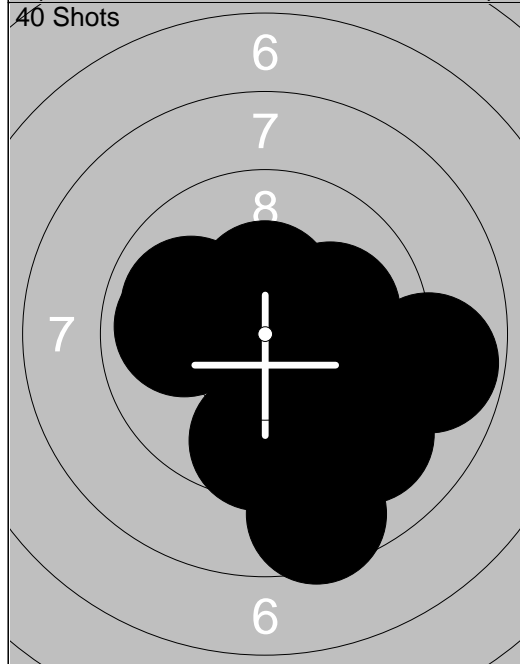

11:	*10.4	↑
12:	10.1	→
13:	9.6	↓
14:	9.9	←
15:	9.2	↙
16:	9.9	→
17:	8.8	→
18:	8.6	↓
19:	*10.9	↓
20:	9.9	↙
Series		91.0
Total		185.0

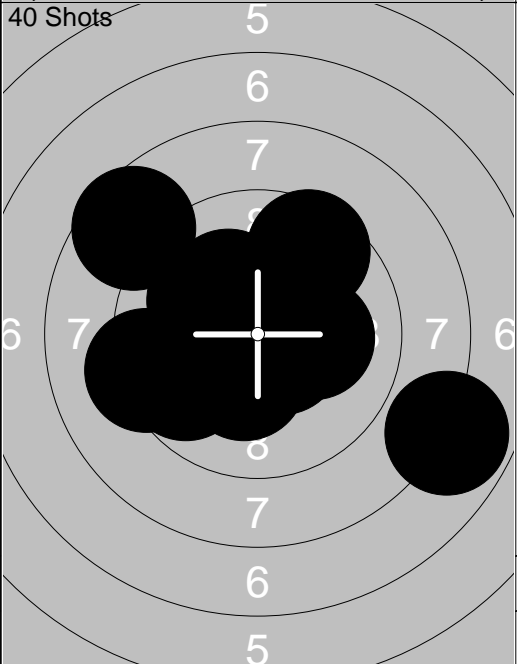

21:	*10.5	↘
22:	8.6	↗
23:	10.1	→
24:	7.9	↘
25:	9.5	↗
26:	*10.3	↓
27:	*10.2	↗
28:	10.1	↙
29:	9.7	↙
30:	9.3	←
Series		92.0
Total		277.0

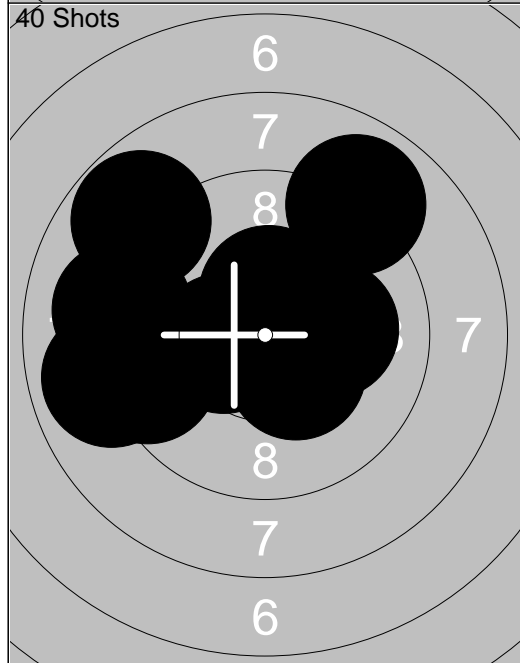

31:	*10.3	→
32:	10.1	→
33:	8.9	↗
34:	*10.4	↘
35:	8.8	↗
36:	*10.4	↑
37:	9.4	←
38:	*10.4	←
39:	8.9	←
40:	9.1	←
Series		92.0
Total		369.0

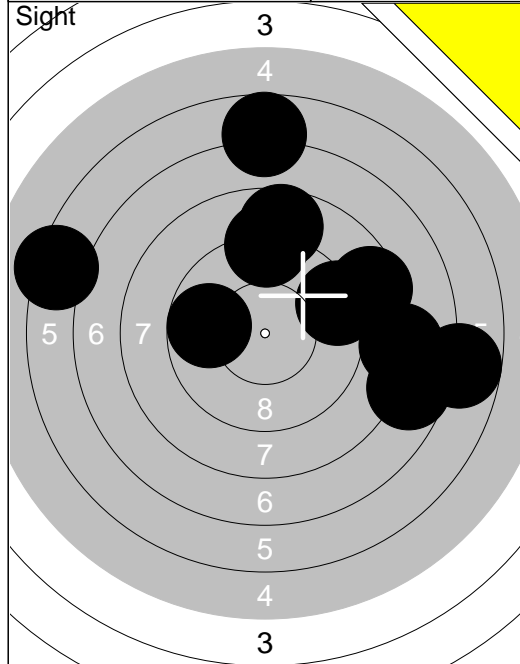

1:	8.5	➔
2:	9.7	➡
3:	8.0	➔
4:	6.7	⬆
5:	8.6	⬆
6:	6.8	➔
7:	6.3	➡
8:	9.3	➔
9:	7.7	➔
10:	9.1	⬆
Series		76.0
Total		0.0

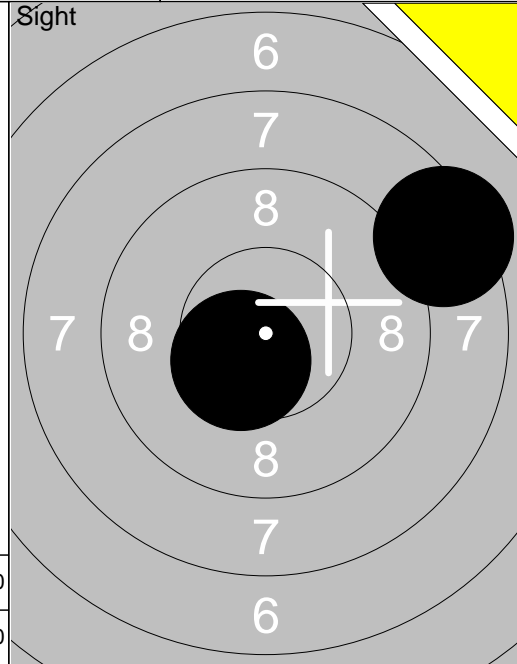

11:	8.4	➔
12:	*10.5	➡
Series		18.0
Total		0.0

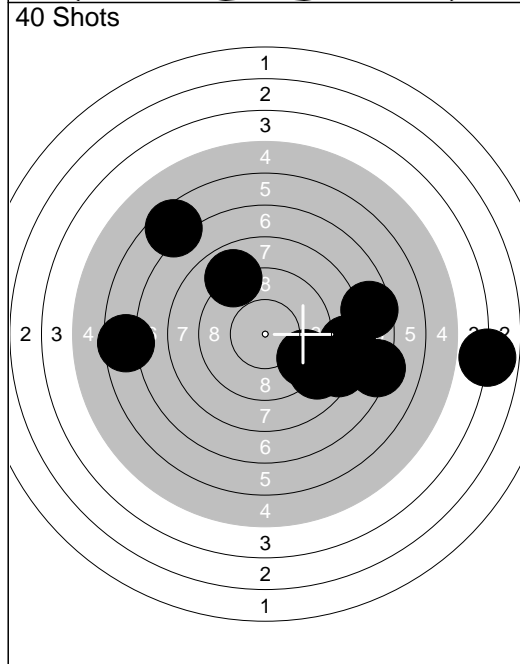

1:	7.3	➔
2:	6.5	➔
3:	3.9	➔
4:	8.9	➡
5:	9.5	➡
6:	8.4	➡
7:	8.3	➔
8:	7.6	➔
9:	8.9	⬆
10:	6.5	➡
Series		70.0
Total		70.0

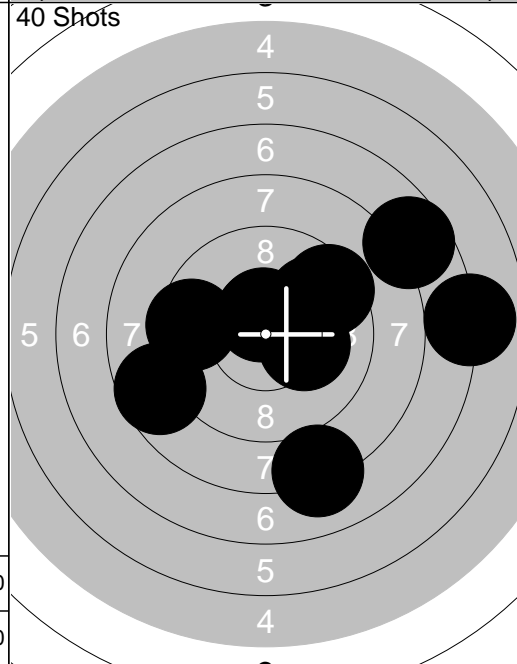

11:	7.0	➔
12:	*10.2	➔
13:	9.8	➔
14:	7.6	➔
15:	9.5	➔
16:	9.5	➡
17:	*10.6	⬆
18:	*10.5	⬆
19:	8.6	➡
20:	8.1	➡
Series		87.0
Total		157.0

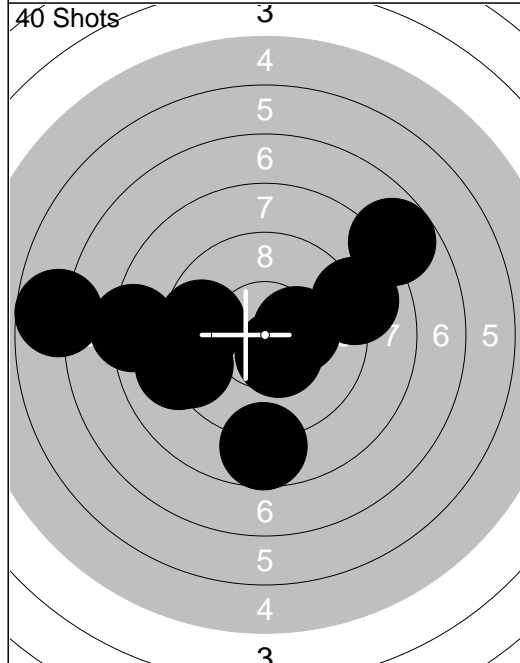

21:	*10.3	➔
22:	9.6	➡
23:	6.7	➡
24:	8.3	➡
25:	*10.5	➡
26:	8.7	➡
27:	9.1	➡
28:	7.7	➔
29:	9.3	➡
30:	9.0	➔
Series		85.0
Total		242.0

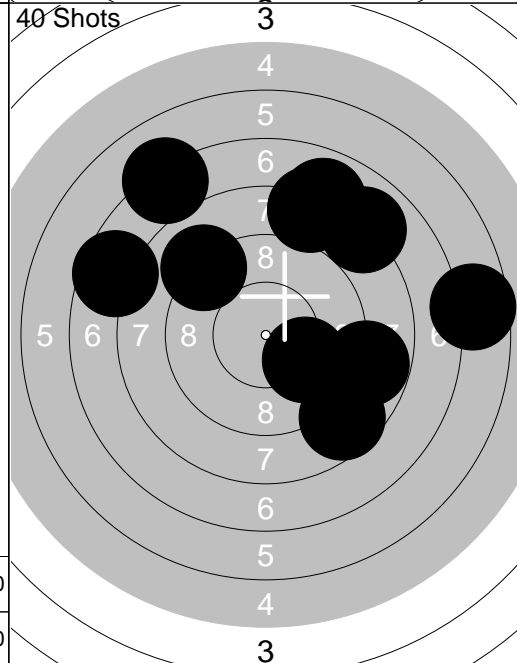

31:	8.8	➔
32:	10.0	➡
33:	8.6	➡
34:	8.0	➔
35:	7.9	⬆
36:	9.0	⬆
37:	7.1	⬆
38:	8.2	⬆
39:	7.6	➡
40:	6.6	➔
Series		78.0
Total		320.0



	<p>1: 10.1 ↗</p> <p>2: 9.7 ↗</p> <p>3: 9.9 ↘</p> <p>4: *10.3 ↘</p> <p>5: 10.1 ↗</p> <p>6: 9.9 ↗</p> <p>7: 9.2 ↘</p> <p>8: 10.1 ↘</p> <p>9: *10.3 ↘</p> <p>10: 9.6 →</p>		<p>11: 9.6 ↘</p> <p>12: *10.2 ↘</p> <p>13: 9.8 ↗</p> <p>14: *10.2 ↘</p> <p>15: 9.8 ↘</p> <p>16: 9.3 ↘</p> <p>17: 9.3 ←</p> <p>18: 9.9 ↑</p> <p>19: *10.2 ↘</p> <p>20: *10.6 ←</p>
Series 95.0		Series 94.0	
Total 0.0		Total 0.0	

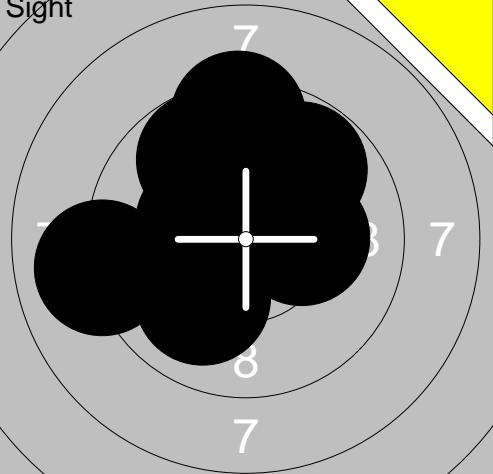
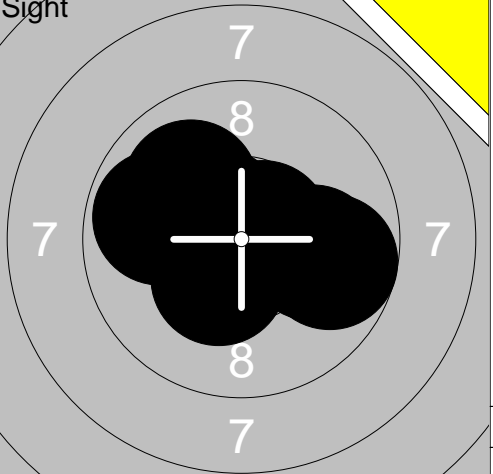

	<p>21: *10.3 ↗</p> <p>22: *10.5 ↘</p>		<p>1: *10.7 →</p> <p>2: *10.2 ↑</p> <p>3: 10.0 ↗</p> <p>4: *10.2 ↗</p> <p>5: *10.2 →</p> <p>6: *10.5 ←</p> <p>7: *10.4 ←</p> <p>8: 10.0 ↑</p> <p>9: *10.2 ↗</p> <p>10: 9.2 ↗</p>
Series 20.0		Series 99.0	
Total 0.0		Total 99.0	

	<p>11: 9.9 →</p> <p>12: *10.4 ↗</p> <p>13: 9.7 ↗</p> <p>14: *10.2 ↑</p> <p>15: 9.4 →</p> <p>16: *10.3 ↗</p> <p>17: 9.9 →</p> <p>18: *10.2 ↘</p> <p>19: 9.8 ↗</p> <p>20: 9.9 ↗</p>		<p>21: 9.7 ↑</p> <p>22: 9.6 ↗</p> <p>23: 9.7 ↗</p> <p>24: 8.7 ↑</p> <p>25: 9.0 →</p> <p>26: 9.0 ↘</p> <p>27: 9.6 ↗</p> <p>28: 8.9 →</p> <p>29: 9.7 ↘</p> <p>30: *10.2 ↘</p>
Series 94.0		Series 89.0	
Total 193.0		Total 282.0	



	<p>31: 8.1 →</p> <p>32: 9.6 →</p> <p>33: *10.2 →</p> <p>34: 10.0 ↑</p> <p>35: 9.2 ↗</p> <p>36: *10.4 ↘</p> <p>37: *10.3 ↗</p> <p>38: 10.0 →</p> <p>39: *10.4 ↗</p> <p>40: *10.3 ↘</p>		
Series 96.0			
Total 378.0			

Sight 	1: *10.4 ← 2: 9.0 ← 3: 10.1 ← 4: 9.8 ↗ 5: 10.0 ↓ 6: *10.4 → 7: 9.8 ↗ 8: *10.2 → 9: 10.0 ↑ 10: 9.4 ↑ <hr/> Series 96.0 Total 0.0	Sight 	11: *10.3 ← 12: *10.5 ↗ 13: 9.8 ← 14: *10.4 ↓ 15: *10.5 ↗ 16: 10.1 ↗ 17: *10.6 → 18: 9.7 → 19: 10.0 → 20: 10.0 ↗ <hr/> Series 98.0 Total 0.0
---	--	---	---

Sight 	21: 9.6 → 22: 10.0 → 23: 9.9 ↑ 24: *10.9 → 25: 10.0 ← <hr/> Series 48.0 Total 0.0	40 Shots 	1: *10.6 ↑ 2: 10.0 ↗ 3: 9.8 ↓ 4: *10.6 ← 5: *10.2 → 6: *10.5 ↓ 7: 10.0 ↓ 8: *10.7 → 9: *10.4 ↓ 10: *10.6 ← <hr/> Series 99.0 Total 99.0
--	---	---	--

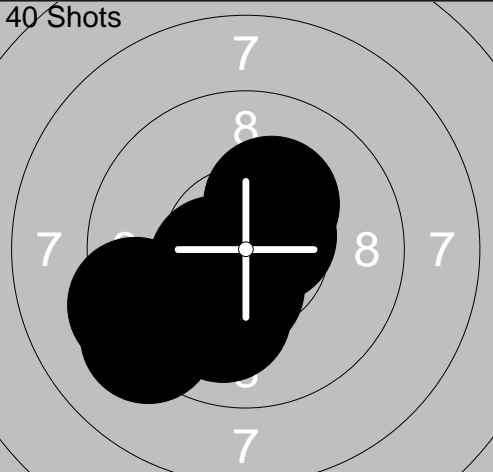
40 Shots 	11: *10.6 ↑ 12: *10.5 ↗ 13: *10.4 ↓ 14: 10.1 ↓ 15: 9.7 ↓ 16: 9.9 ← 17: *10.2 → 18: 10.1 ↑ 19: *10.4 ↑ 20: *10.5 ↓ <hr/> Series 98.0 Total 197.0	40 Shots 	21: *10.3 ↓ 22: *10.7 → 23: 10.1 ↗ 24: *10.4 ↓ 25: 9.8 ↓ 26: *10.6 ↓ 27: *10.6 ← 28: 10.0 ↓ 29: *10.2 ↓ 30: *10.3 ↓ <hr/> Series 99.0 Total 296.0
--	--	--	--

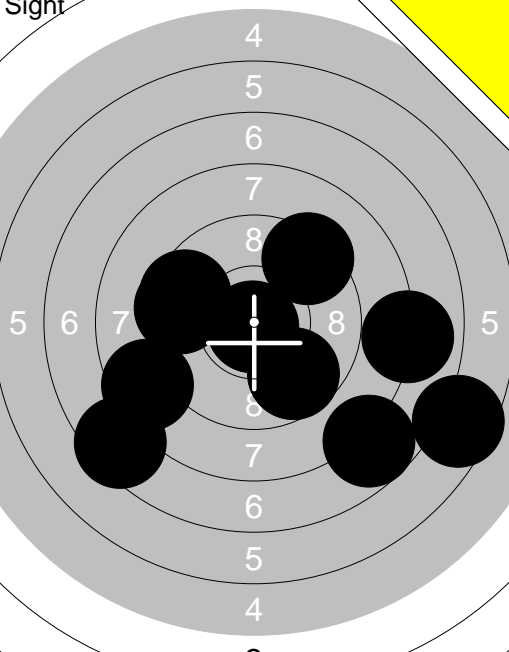
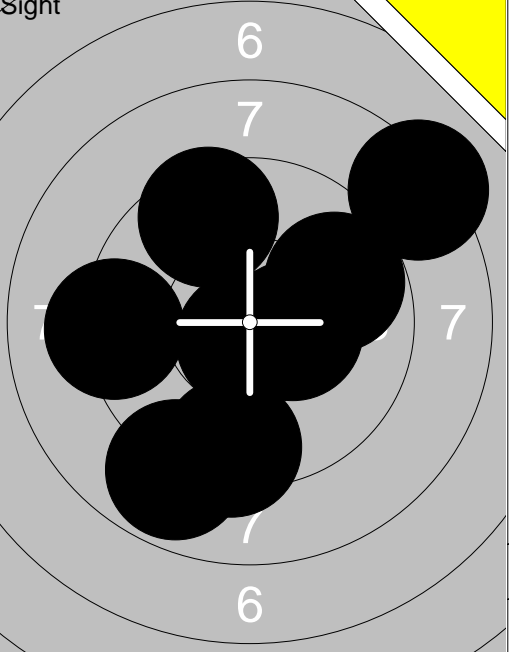
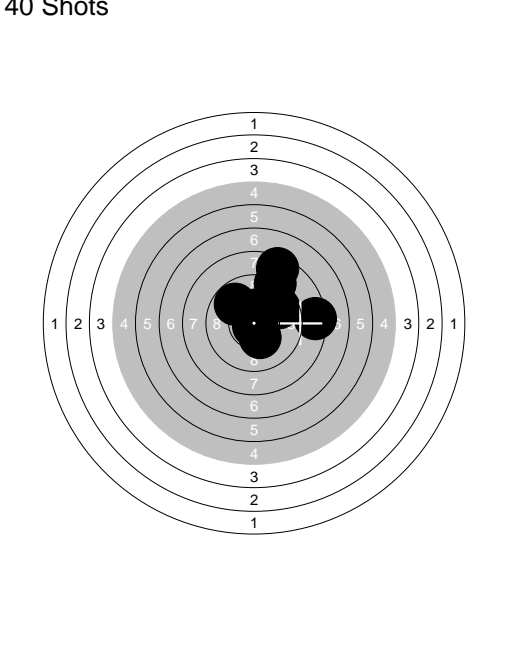
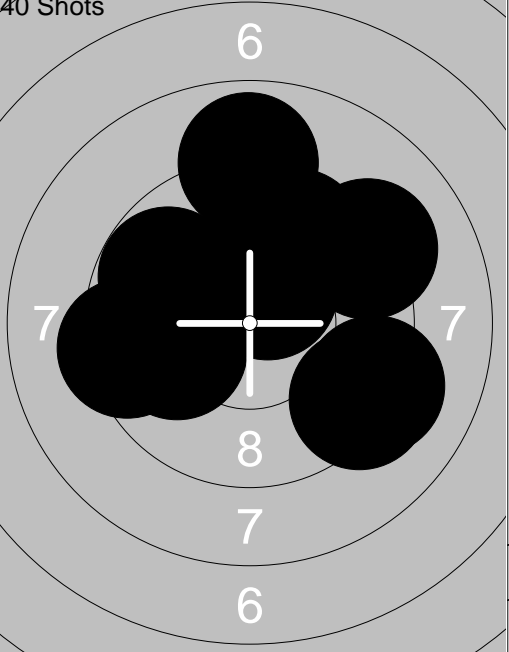
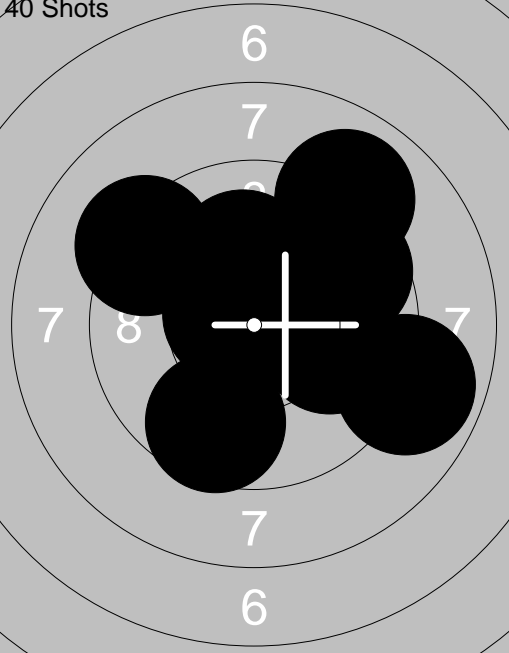
40 Shots 	31: 9.3 ← 32: 9.2 ← 33: *10.4 ↓ 34: *10.6 ↗ 35: *10.3 ↗ 36: *10.6 ← 37: 10.0 ↓ 38: *10.7 ↓ 39: 10.1 ↓ 40: *10.5 ← <hr/> Series 98.0 Total 394.0		
--	--	--	--

Relay	Lane	Joel Persson			
10m	Ramselefors	9	Vb		
26-01-2013	Förbundsmästerskap 2013	Ramselefors SKF			
Sight		1: 9.3 ↗ 2: 7.9 → 3: 9.7 ↘ 4: 6.5 ↘ 5: *10.9 ↓ 6: 7.7 ↘ 7: 8.5 ← 8: 9.5 ← 9: 7.5 ↘ 10: 9.5 ←	Sight		11: 9.8 ↗ 12: *10.7 ↓ 13: 9.3 ↓ 14: 9.5 ↗ 15: 8.2 ↗ 16: 9.2 ← 17: 8.8 ↓ 18: *10.4 →
		Series 81.0		Series 72.0	
		Total 0.0		Total 0.0	
40 Shots		1: 9.9 ↗ 2: 0.0 → 3: *10.3 ↓ 4: 9.7 ↗ 5: *10.4 ↑ 6: 9.0 ↗ 7: 8.3 → 8: 8.4 ↗ 9: *10.8 ↓ 10: 9.8 ↖	40 Shots		11: 9.2 ↗ 12: 9.4 ← 13: 8.9 ↑ 14: 9.7 ↗ 15: 9.2 ↘ 16: *10.4 ↑ 17: *10.5 ↗ 18: 9.8 ↖ 19: 10.0 ← 20: 9.2 ↘
		Series 82.0		Series 92.0	
		Total 82.0		Total 174.0	
40 Shots		21: 10.1 ↑ 22: *10.2 → 23: 10.0 → 24: 9.8 ↗ 25: *10.6 ↖ 26: 9.0 ↗ 27: 9.6 ↓ 28: 9.6 ↗ 29: 8.9 → 30: 9.2 ↖	40 Shots		31: *10.4 ↖ 32: 9.1 ↗ 33: 10.0 ↖ 34: 9.4 → 35: 9.2 ↗ 36: 10.1 ← 37: *10.5 → 38: *10.3 ↑ 39: 9.5 ↓ 40: 8.9 ↖
		Series 93.0		Series 94.0	
		Total 267.0		Total 361.0	

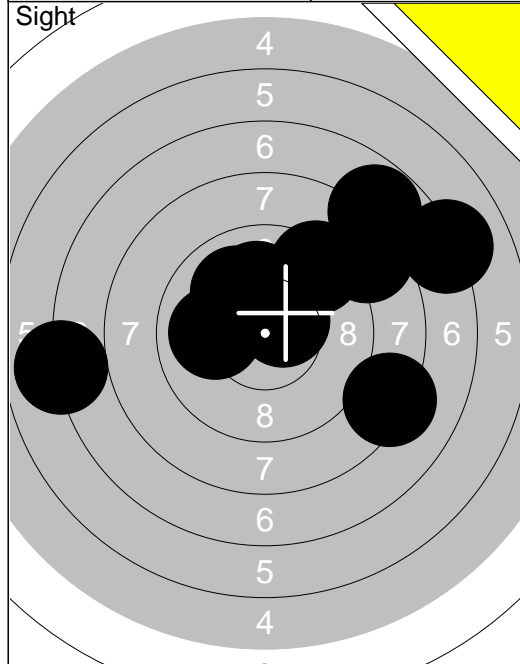

1:	8.2	↘
2:	9.3	↗
3:	10.0	←
4:	10.0	↖
5:	8.5	↗
6:	*10.5	↗
7:	7.1	↗
8:	7.8	↗
9:	10.1	↑
10:	7.0	←
Series		86.0
Total		0.0

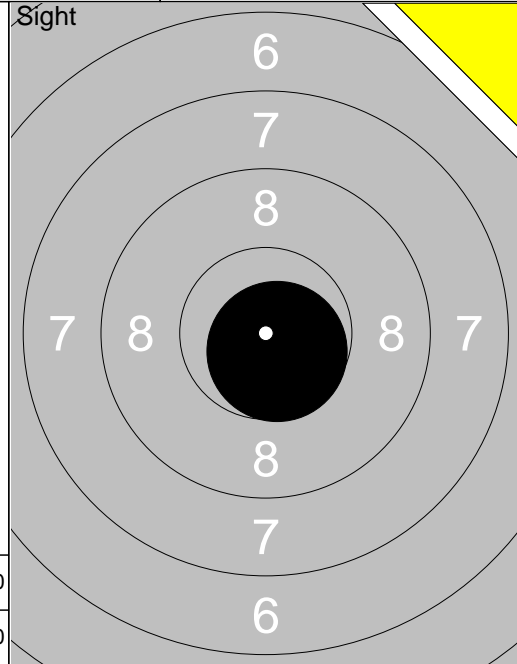

11:	*10.7	↘
Series		10.0
Total		0.0

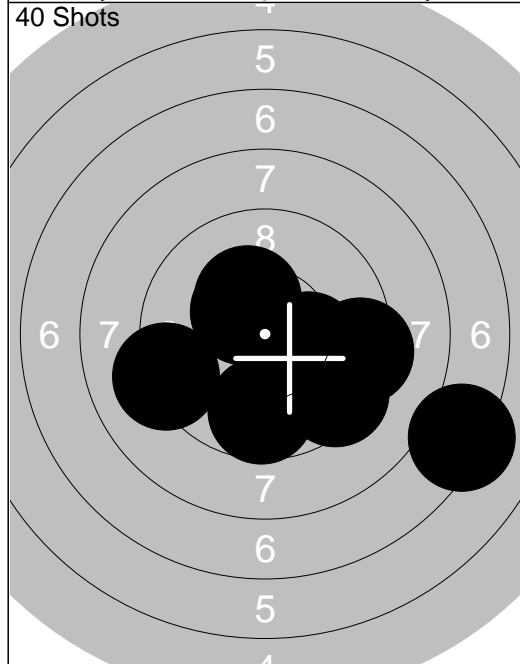

1:	9.1	←
2:	*10.4	↗
3:	*10.3	↗
4:	10.1	→
5:	7.2	→
6:	9.7	→
7:	9.3	→
8:	*10.2	→
9:	9.4	→
10:	9.7	↓
Series		92.0
Total		92.0

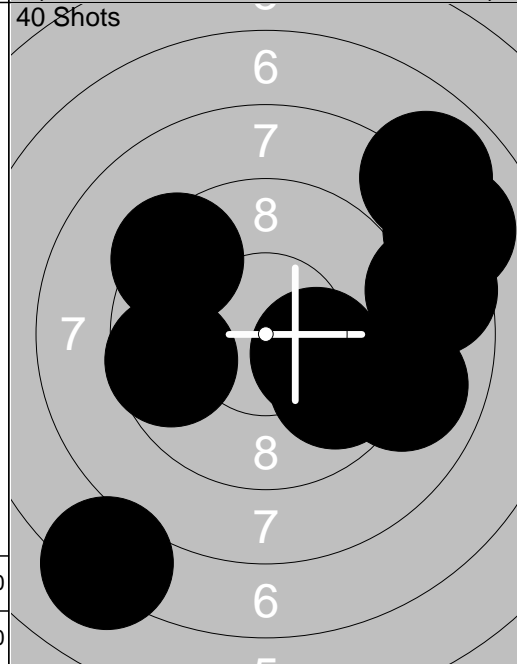

11:	9.6	←
12:	9.9	↘
13:	9.8	↘
14:	9.0	→
15:	8.6	→
16:	8.1	↗
17:	7.9	↗
18:	*10.2	→
19:	7.2	↙
20:	9.4	↖
Series		85.0
Total		177.0

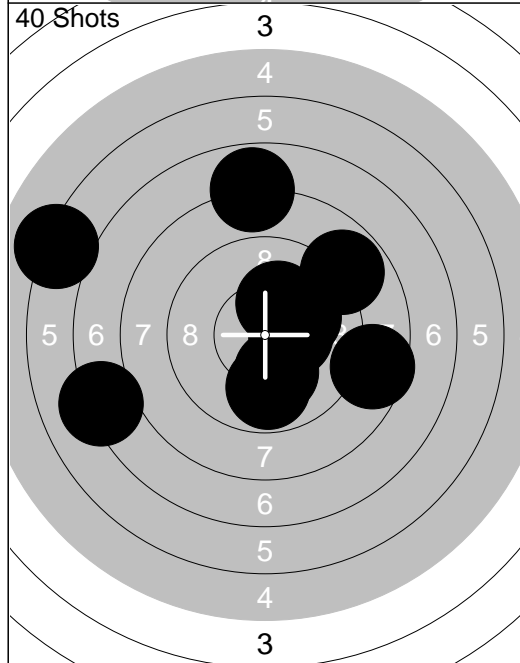

21:	10.1	↓
22:	8.8	↗
23:	8.6	→
24:	*10.2	↗
25:	*10.4	→
26:	7.2	←
27:	7.8	↑
28:	9.8	↓
29:	10.1	↗
30:	6.1	←
Series		85.0
Total		262.0

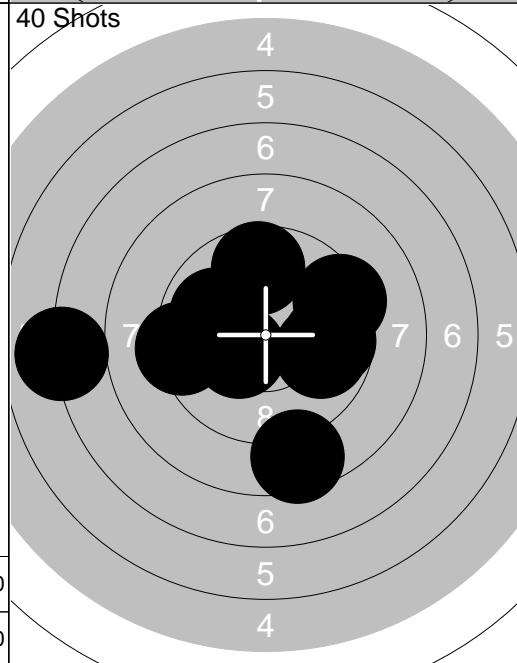

31:	7.0	←
32:	9.4	↗
33:	8.5	↓
34:	*10.3	↖
35:	9.7	→
36:	9.3	←
37:	9.9	↖
38:	9.8	→
39:	9.7	↑
40:	10.1	←
Series		89.0
Total		351.0



<p>Sight</p>	<p>Sight</p>
<p>1: 3.6 ↙</p> <p>2: 10.0 ↓</p> <p>3: 7.1 ↓</p> <p>4: 8.5 ↓</p> <p>5: *10.4 ↗</p> <p>6: *10.2 ↗</p> <p>7: 9.2 ↘</p> <p>8: 9.7 ↑</p> <p>9: 10.1 ↓</p> <p>10: *10.3 ↖</p>	<p>11: *10.4 ↘</p>
<p>Series 86.0</p> <p>Total 0.0</p>	<p>Series 10.0</p> <p>Total 0.0</p>

<p>40 Shots</p>	<p>40 Shots</p>
<p>1: 9.9 ↓</p> <p>2: 10.0 ↓</p> <p>3: 9.8 ←</p> <p>4: *10.6 ↗</p> <p>5: *10.7 ↖</p> <p>6: 9.6 ←</p> <p>7: 9.8 ↗</p> <p>8: *10.8 ↗</p> <p>9: *10.5 ↓</p> <p>10: *10.6 ↘</p>	<p>11: *10.3 ←</p> <p>12: 9.7 ↓</p> <p>13: *10.5 ↗</p> <p>14: *10.2 ↘</p> <p>15: *10.3 ↓</p> <p>16: *10.5 ↓</p> <p>17: 10.1 ←</p> <p>18: *10.7 ↗</p> <p>19: 9.8 ←</p> <p>20: 10.0 ↖</p>
<p>Series 96.0</p> <p>Total 96.0</p>	<p>Series 98.0</p> <p>Total 194.0</p>

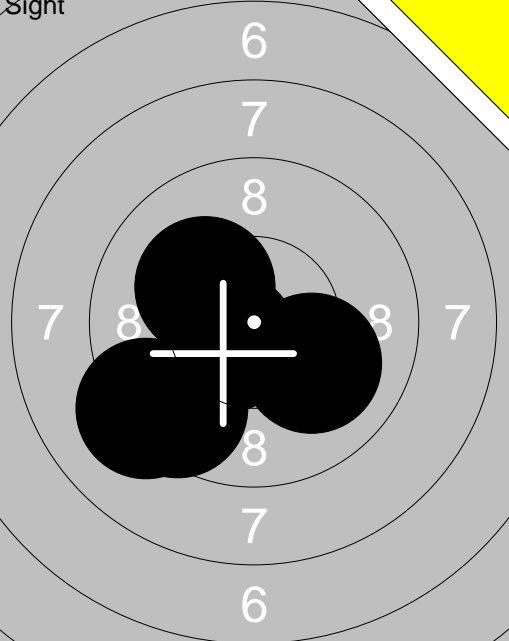
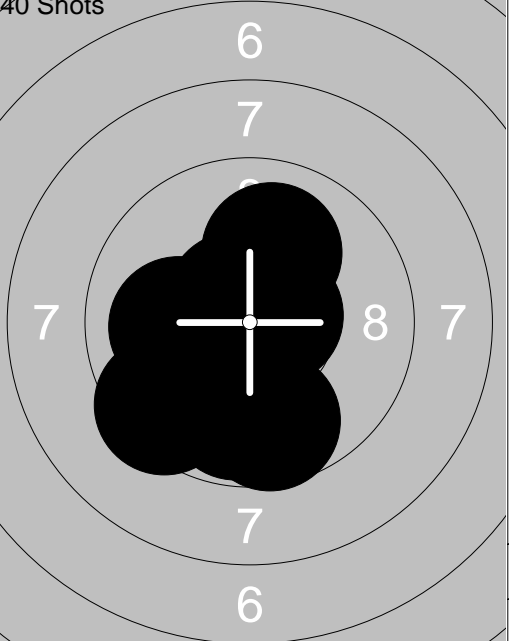
<p>40 Shots</p>	<p>40 Shots</p>
<p>21: 9.9 ↑</p> <p>22: *10.3 ↘</p> <p>23: 9.3 ↑</p> <p>24: *10.4 →</p> <p>25: *10.7 ↓</p> <p>26: *10.4 ↓</p> <p>27: *10.2 ↑</p> <p>28: *10.5 ↑</p> <p>29: *10.6 ↗</p> <p>30: *10.5 ↗</p>	<p>31: *10.7 ↓</p> <p>32: 9.7 ↖</p> <p>33: *10.4 ←</p> <p>34: 9.7 ↗</p> <p>35: *10.5 ↓</p> <p>36: *10.8 ←</p> <p>37: 10.0 ↗</p> <p>38: *10.2 ↖</p> <p>39: *10.2 ↑</p> <p>40: 9.1 ↖</p>
<p>Series 98.0</p> <p>Total 292.0</p>	<p>Series 97.0</p> <p>Total 389.0</p>

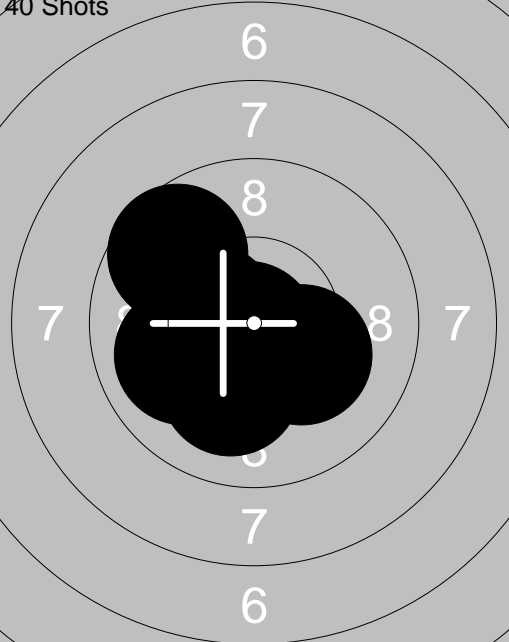
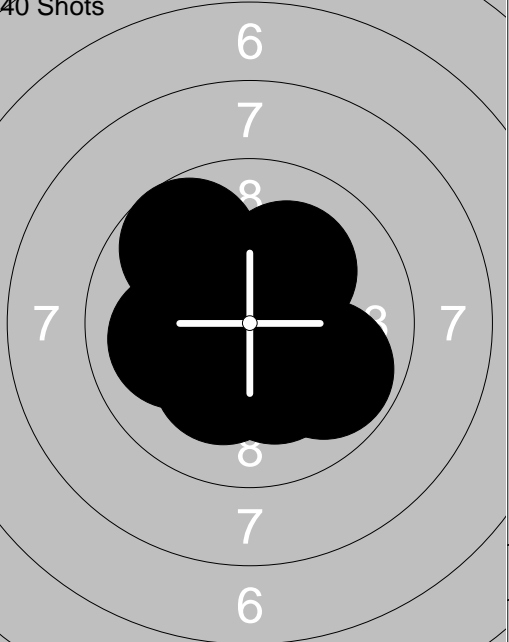
<p>Sight</p> 	<p>40 Shots</p> 	<p>1: 10.0 ↗</p> <p>2: *10.2 ↖</p> <p>3: 9.2 ↙</p> <p>4: 9.5 ↙</p> <p>5: *10.5 ↙</p> <hr/> <p>Series 48.0</p> <p>Total 0.0</p>	<p>1: 10.0 ↗</p> <p>2: 9.4 ↙</p> <p>3: *10.6 ↖</p> <p>4: *10.8 ↙</p> <p>5: 9.8 ↓</p> <p>6: *10.8 ↙</p> <p>7: 10.0 ←</p> <p>8: 10.0 ↓</p> <p>9: 9.7 ↓</p> <p>10: *10.6 →</p> <hr/> <p>Series 97.0</p> <p>Total 97.0</p>
---	--	--	--

<p>40 Shots</p> 	<p>40 Shots</p> 	<p>11: 10.0 ↙</p> <p>12: *10.3 ↓</p> <p>13: 10.1 ↓</p> <p>14: *10.2 →</p> <p>15: *10.8 ↙</p> <p>16: 9.6 ↖</p> <p>17: 10.1 ↙</p> <p>18: *10.2 ↙</p> <p>19: *10.3 ↙</p> <p>20: 10.1 ↙</p> <hr/> <p>Series 99.0</p> <p>Total 196.0</p>	<p>21: *10.4 ↓</p> <p>22: *10.5 ↙</p> <p>23: 9.7 ↗</p> <p>24: 10.0 ←</p> <p>25: *10.2 ↓</p> <p>26: *10.2 ↙</p> <p>27: 10.1 ↗</p> <p>28: 9.8 ↘</p> <p>29: *10.9 ↙</p> <p>30: *10.4 ↙</p> <hr/> <p>Series 98.0</p> <p>Total 294.0</p>
---	---	---	---

<p>40 Shots</p> 	<p>40 Shots</p> 	<p>31: *10.5 ↗</p> <p>32: 9.9 ↗</p> <p>33: *10.8 ↗</p> <p>34: *10.6 →</p> <p>35: *10.7 ←</p> <p>36: *10.5 ↓</p> <p>37: *10.3 →</p> <p>38: *10.4 →</p> <p>39: *10.5 →</p> <p>40: *10.8 ↗</p> <hr/> <p>Series 99.0</p> <p>Total 393.0</p>	
--	--	---	--

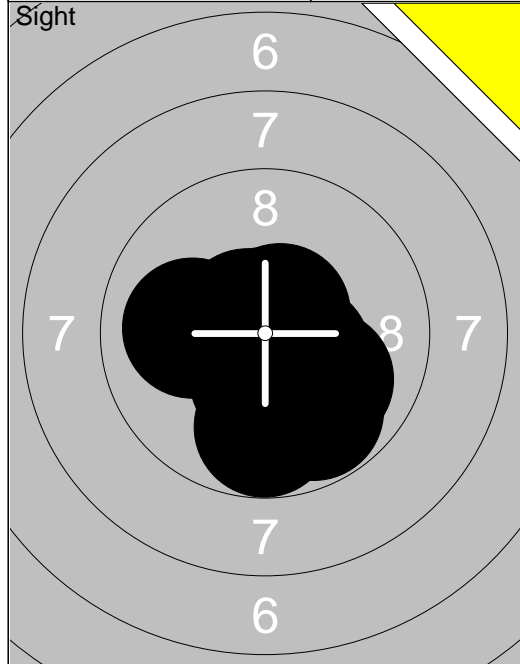

1:	*10.4	↘
2:	10.0	↘
3:	9.8	↘
4:	10.0	↘
5:	*10.4	↓
6:	9.8	↓
7:	*10.6	↗
8:	*10.9	↗
9:	*10.7	↖
10:	10.0	←
Series		98.0
Total		0.0

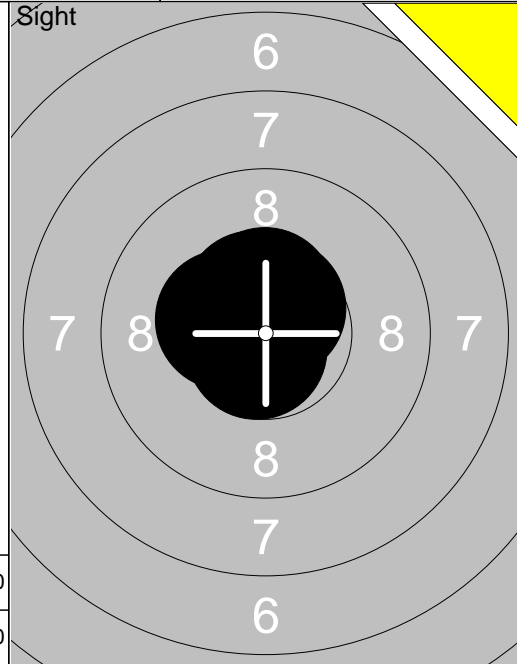

11:	*10.4	↖
12:	*10.5	↗
13:	*10.7	↗
14:	*10.6	↗
15:	*10.7	↘
16:	*10.5	↖
17:	*10.5	↑
18:	*10.6	↗
19:	*10.8	↖
Series		90.0
Total		0.0

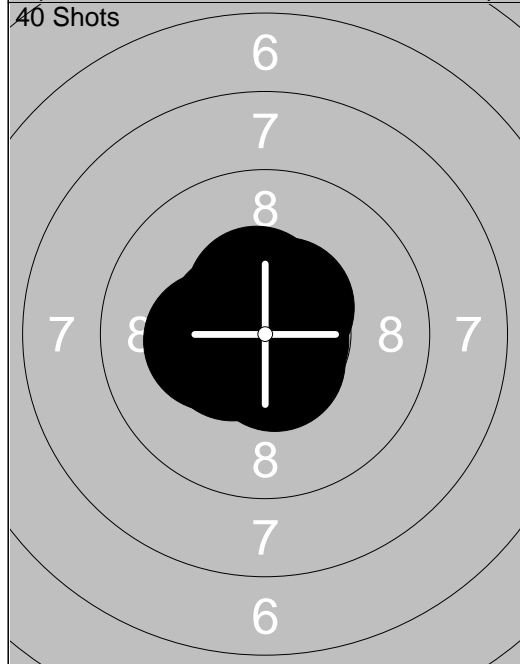

1:	*10.5	↗
2:	*10.7	↗
3:	*10.6	↗
4:	*10.6	↖
5:	*10.5	↗
6:	*10.9	↗
7:	*10.3	←
8:	*10.8	↘
9:	*10.6	↓
10:	*10.5	↖
Series		100.0
Total		100.0

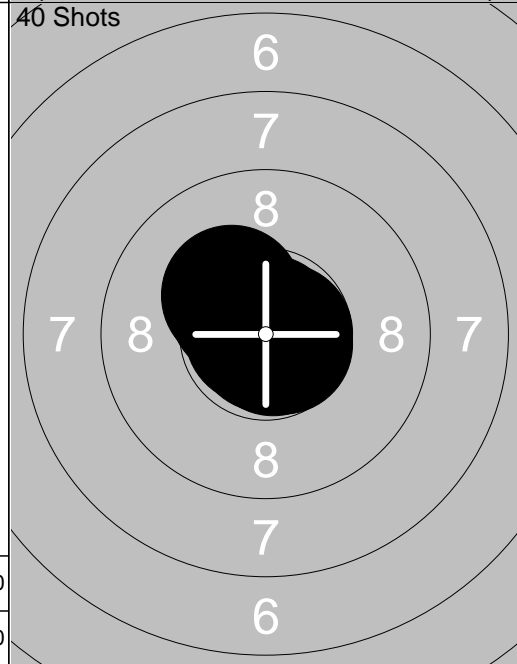

11:	*10.3	↖
12:	*10.9	↓
13:	*10.9	↗
14:	*10.8	↗
15:	*10.8	←
16:	*10.9	↗
17:	*10.7	↘
18:	*10.5	↗
19:	*10.7	→
20:	*10.8	↘
Series		100.0
Total		200.0

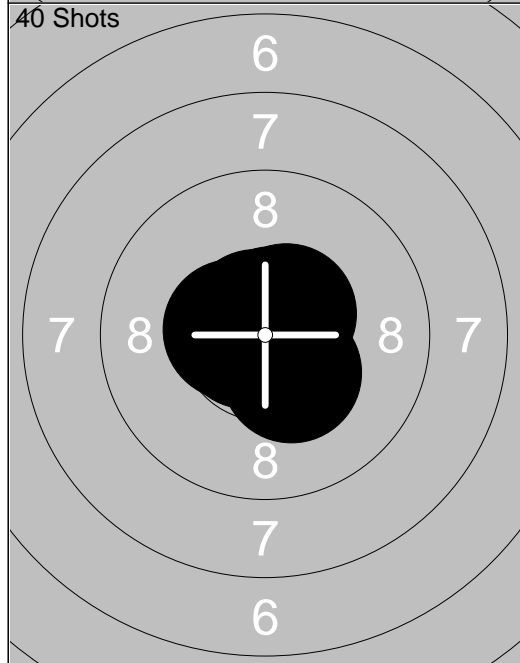

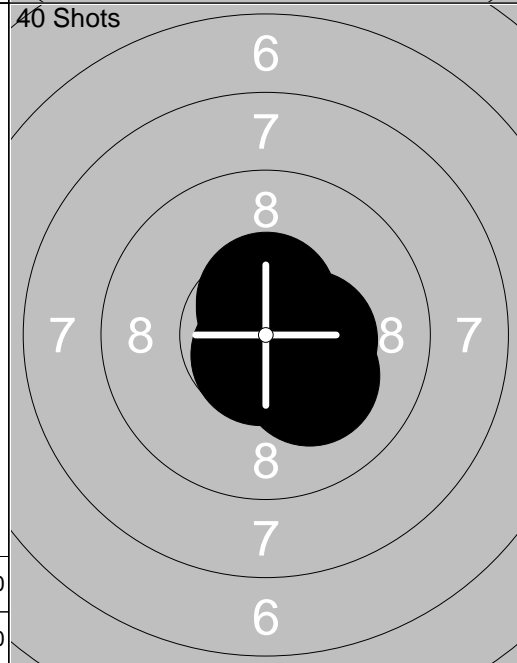

21:	*10.7	←
22:	*10.4	↘
23:	*10.9	↘
24:	*10.8	←
25:	*10.5	←
26:	*10.7	↗
27:	*10.7	↗
28:	*10.7	↗
29:	*10.6	↗
30:	*10.8	↘
Series		100.0
Total		300.0

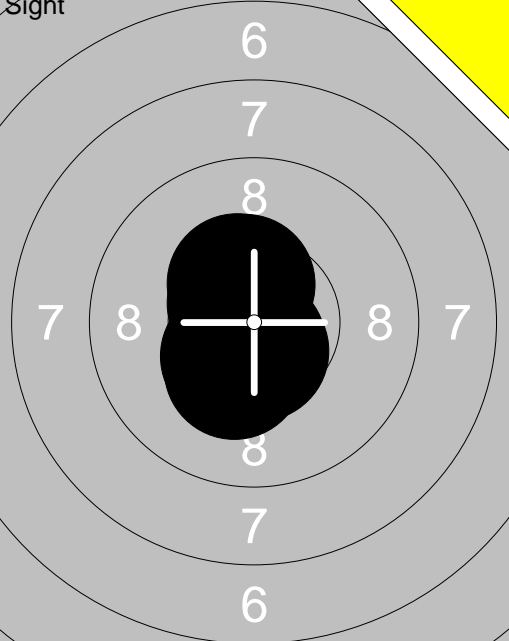
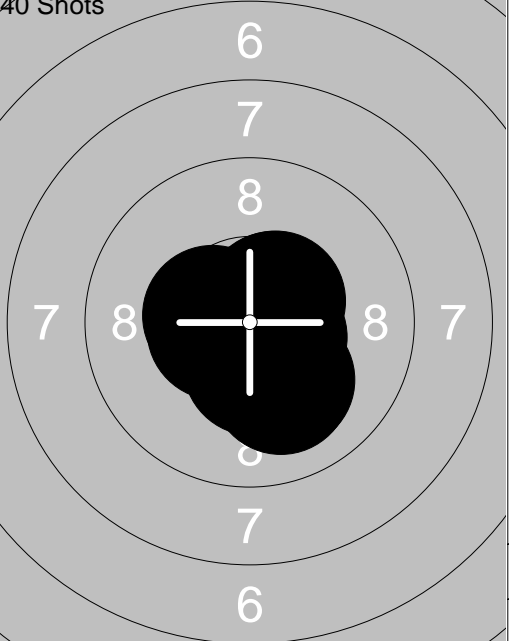

31:	*10.6	↗
32:	*10.8	↘
33:	*10.5	↗
34:	*10.7	↘
35:	*10.8	↘
36:	*10.4	→
37:	*10.2	↘
38:	*10.7	↘
39:	*10.5	↘
40:	*10.7	↘
Series		100.0
Total		400.0

<p>Sight</p> 	<p>40 Shots</p> 	<p>1: *10.6 ↖</p> <p>2: *10.5 ↑</p> <p>3: *10.4 ↗</p> <p>4: *10.7 ↓</p> <p>5: *10.4 ↘</p> <p>6: *10.8 ↙</p> <p>7: *10.6 ↓</p> <p>8: *10.7 ↓</p> <p>9: *10.3 ↓</p> <p>10: *10.6 ↓</p> <hr/> <p>Series 100.0</p> <hr/> <p>Total 0.0</p>	<p>1: *10.5 ←</p> <p>2: *10.8 ↗</p> <p>3: 10.1 ↘</p> <p>4: *10.6 ↗</p> <p>5: *10.5 ←</p> <p>6: *10.5 ↗</p> <p>7: 10.1 ↘</p> <p>8: *10.8 ↓</p> <p>9: *10.6 ↘</p> <p>10: *10.4 ↓</p> <hr/> <p>Series 100.0</p> <hr/> <p>Total 100.0</p>
---	--	---	---

<p>40 Shots</p> 	<p>40 Shots</p> 	<p>11: *10.4 ↓</p> <p>12: *10.3 ↓</p> <p>13: *10.7 ↓</p> <p>14: *10.3 →</p> <p>15: *10.6 ↗</p> <p>16: *10.7 ↓</p> <p>17: *10.7 ↗</p> <p>18: 10.0 ↘</p> <p>19: *10.9 ←</p> <p>20: *10.6 →</p> <hr/> <p>Series 100.0</p> <hr/> <p>Total 200.0</p>	<p>21: *10.3 ↓</p> <p>22: *10.5 ↗</p> <p>23: *10.7 ↘</p> <p>24: *10.7 ↓</p> <p>25: *10.5 ↘</p> <p>26: *10.2 ↘</p> <p>27: *10.7 ↗</p> <p>28: *10.2 ←</p> <p>29: *10.4 →</p> <p>30: *10.4 ↙</p> <hr/> <p>Series 100.0</p> <hr/> <p>Total 300.0</p>
---	---	---	--

<p>40 Shots</p> 	<p>31: *10.6 ↖</p> <p>32: *10.7 ↖</p> <p>33: *10.6 ←</p> <p>34: *10.7 ↓</p> <p>35: *10.3 ↑</p> <p>36: *10.8 ↖</p> <p>37: *10.5 ↘</p> <p>38: *10.9 ↘</p> <p>39: *10.8 ↓</p> <p>40: *10.2 ←</p> <hr/> <p>Series 100.0</p> <hr/> <p>Total 400.0</p>		
--	--	--	--

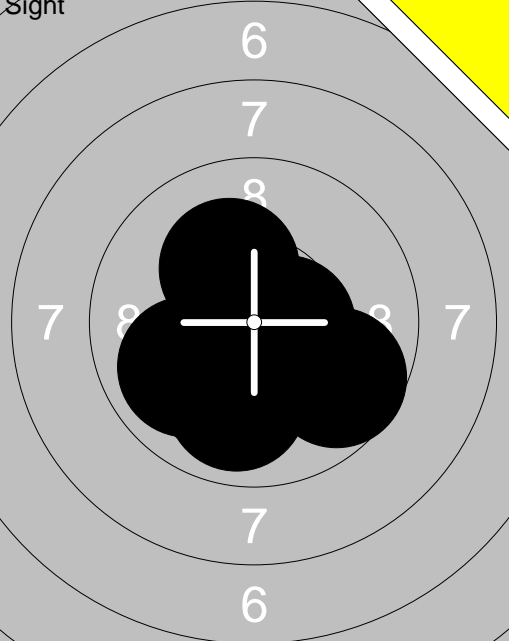
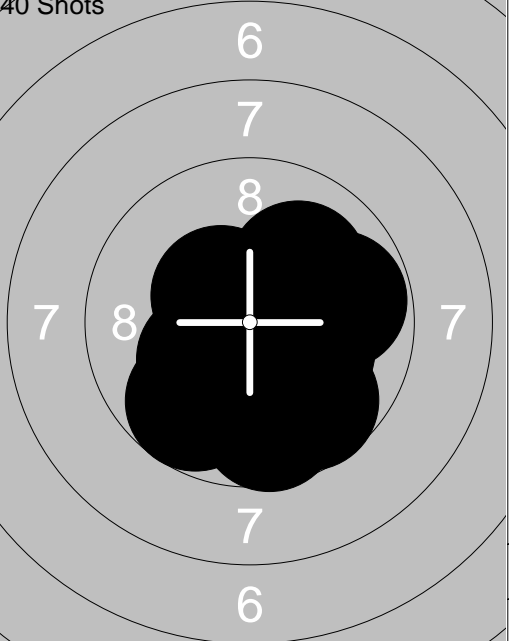
<p>Sight</p> 	<p>40 Shots</p> 	<p>1: *10.7 ↗</p> <p>2: *10.7 ↘</p> <p>3: *10.3 ↙</p> <p>4: 10.1 ↓</p> <p>5: 9.7 ↘</p> <p>6: 9.9 ↓</p> <p>7: 9.9 ↙</p> <p>8: *10.4 ↘</p> <p>9: *10.2 ↗</p> <p>10: *10.5 →</p> <hr/> <p>Series 97.0</p> <hr/> <p>Total 0.0</p>	<p>1: *10.9 ↗</p> <p>2: *10.2 ↘</p> <p>3: 9.7 ↓</p> <p>4: 10.0 ↗</p> <p>5: 9.8 →</p> <p>6: *10.2 ↙</p> <p>7: 9.7 ↙</p> <p>8: *10.7 ↓</p> <p>9: *10.4 ↖</p> <p>10: 9.7 ↓</p> <hr/> <p>Series 96.0</p> <hr/> <p>Total 96.0</p>
---	--	---	--

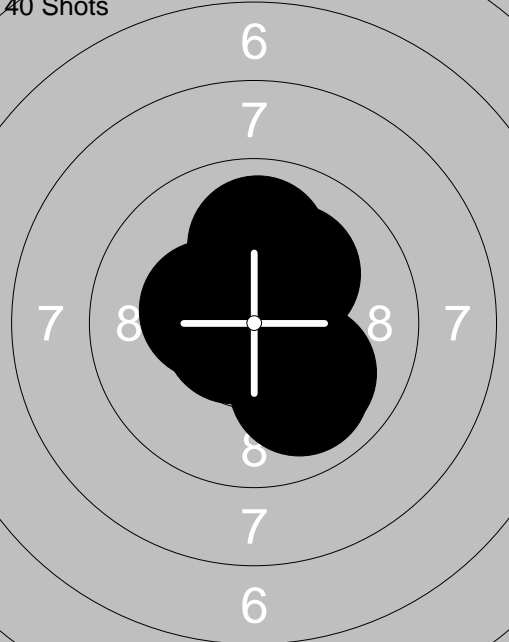
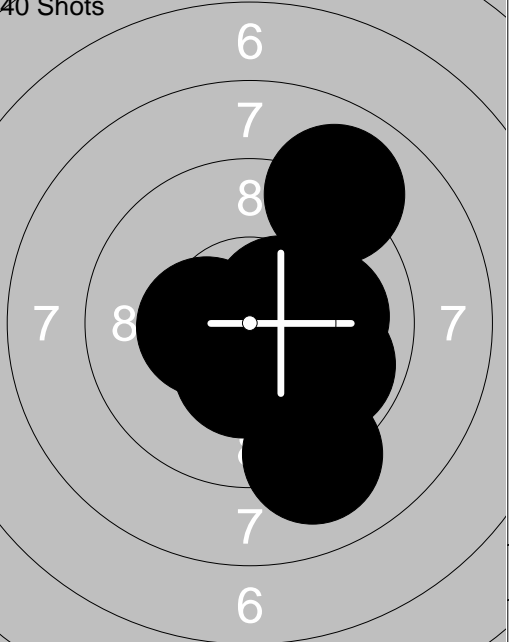
<p>40 Shots</p> 	<p>40 Shots</p> 	<p>11: 10.0 ↘</p> <p>12: *10.7 ↘</p> <p>13: *10.7 ↙</p> <p>14: *10.2 ↗</p> <p>15: *10.5 ↗</p> <p>16: *10.2 ↗</p> <p>17: *10.5 ↗</p> <p>18: 10.0 ↗</p> <p>19: *10.4 ↖</p> <p>20: 10.0 ↘</p> <hr/> <p>Series 100.0</p> <hr/> <p>Total 196.0</p>	<p>21: *10.4 ←</p> <p>22: *10.6 ↙</p> <p>23: 9.0 ↗</p> <p>24: 10.1 →</p> <p>25: *10.5 ↘</p> <p>26: 9.8 ↘</p> <p>27: 9.1 ↓</p> <p>28: *10.2 ↘</p> <p>29: *10.5 ↗</p> <p>30: *10.4 ↓</p> <hr/> <p>Series 97.0</p> <hr/> <p>Total 293.0</p>
---	---	---	--

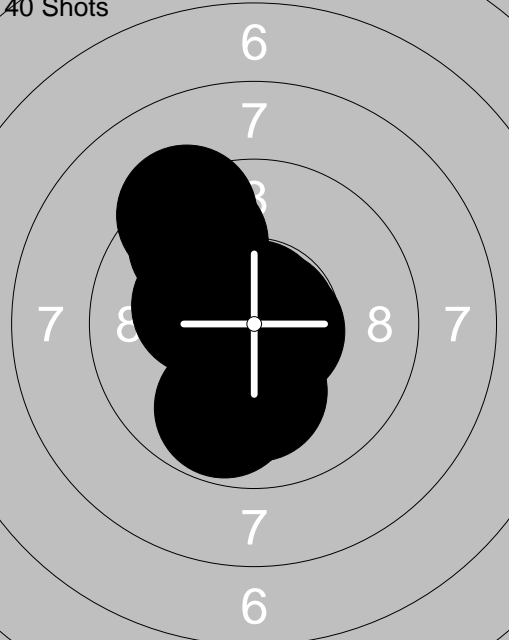
<p>40 Shots</p> 	<p>31: *10.8 →</p> <p>32: *10.2 ↖</p> <p>33: *10.5 ↓</p> <p>34: 9.7 ↗</p> <p>35: *10.3 ↖</p> <p>36: 10.1 ↓</p> <p>37: 9.8 ↓</p> <p>38: 9.3 ↗</p> <p>39: *10.7 →</p> <p>40: *10.8 ↗</p> <hr/> <p>Series 97.0</p> <hr/> <p>Total 390.0</p>		
--	--	--	--

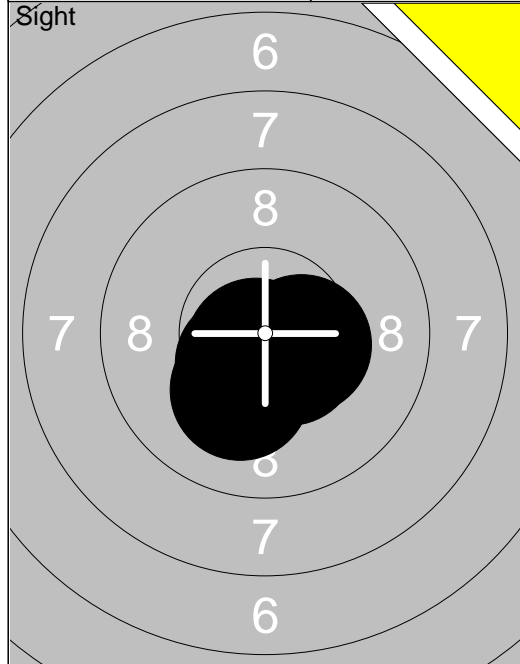

1:	*10.2	↘
2:	*10.5	↘
3:	*10.7	↘
4:	*10.5	→
5:	*10.5	↘
6:	*10.7	↘
Series		60.0
Total		0.0

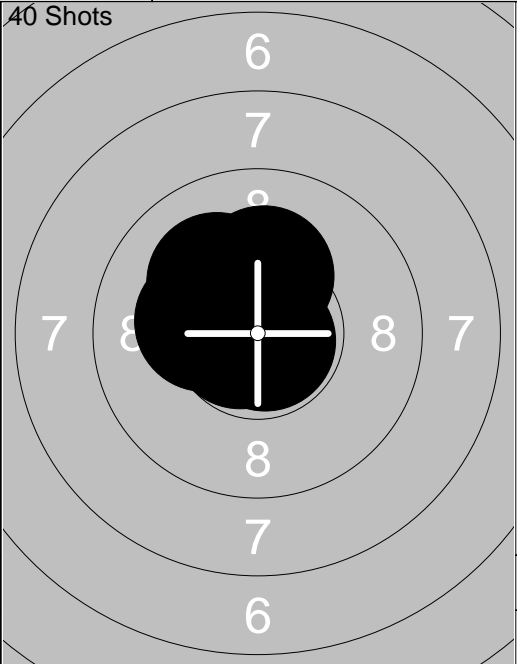

1:	*10.7	←
2:	*10.3	←
3:	*10.6	↗
4:	*10.8	↘
5:	*10.4	↖
6:	*10.3	↑
7:	*10.2	↑
8:	*10.7	↖
9:	*10.8	↑
10:	10.1	↖
Series		100.0
Total		100.0

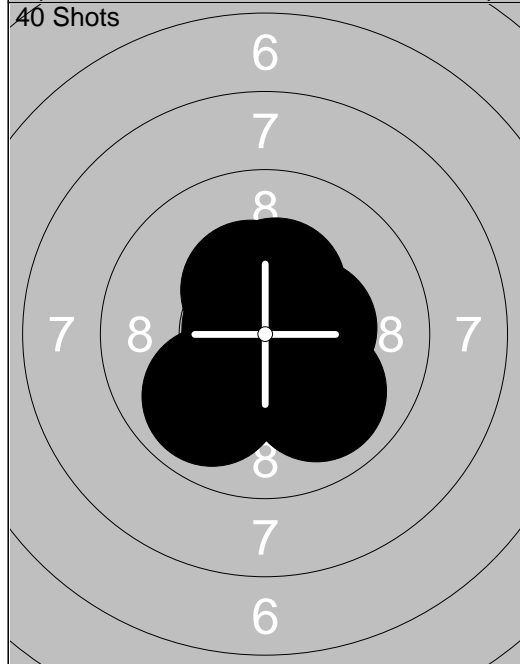

11:	*10.3	↑
12:	*10.4	↑
13:	*10.8	↓
14:	*10.8	↖
15:	*10.8	↓
16:	*10.8	←
17:	10.0	↘
18:	9.9	↘
19:	*10.4	→
20:	*10.6	↘
Series		99.0
Total		199.0

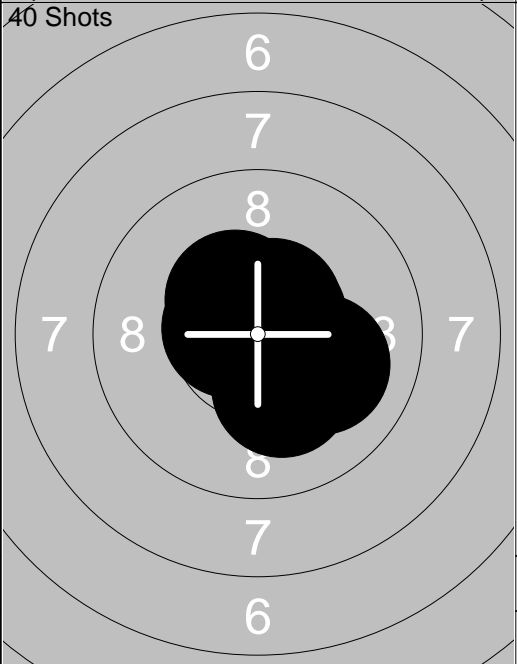

21:	10.1	↘
22:	*10.6	↗
23:	*10.6	↗
24:	*10.2	↓
25:	*10.7	↓
26:	*10.6	↑
27:	*10.5	↘
28:	*10.4	↖
29:	*10.6	←
30:	*10.8	↗
Series		100.0
Total		299.0

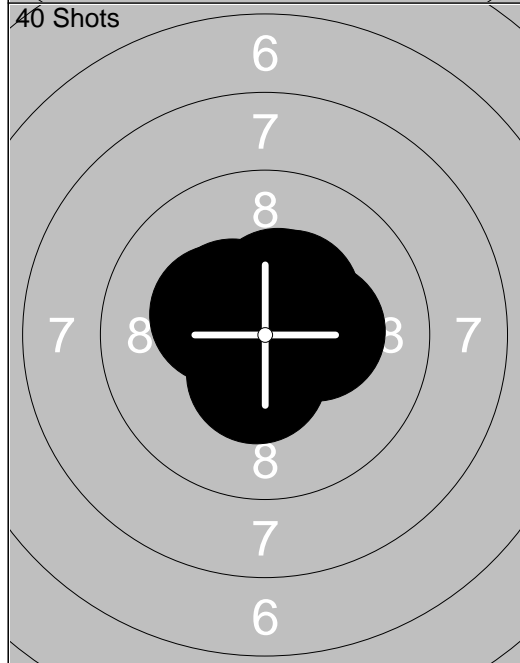

31:	*10.9	↘
32:	*10.5	↑
33:	*10.8	←
34:	*10.8	↖
35:	*10.7	↗
36:	*10.4	↗
37:	*10.4	↓
38:	*10.3	←
39:	*10.4	↖
40:	*10.3	→
Series		100.0
Total		399.0

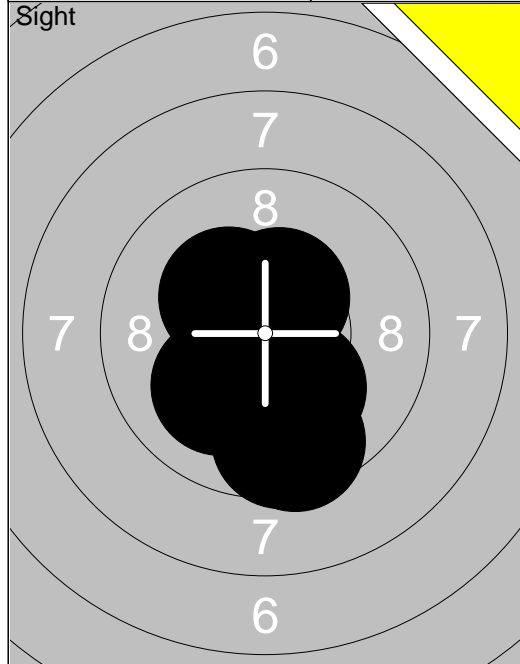

1:	10.1	↙
2:	9.5	↓
3:	10.1	↓
4:	*10.7	↗
5:	*10.3	↗
6:	9.6	↓
7:	*10.8	↗
8:	*10.5	↓
9:	*10.4	↓
10:	*10.5	↗
Series		98.0
Total		0.0

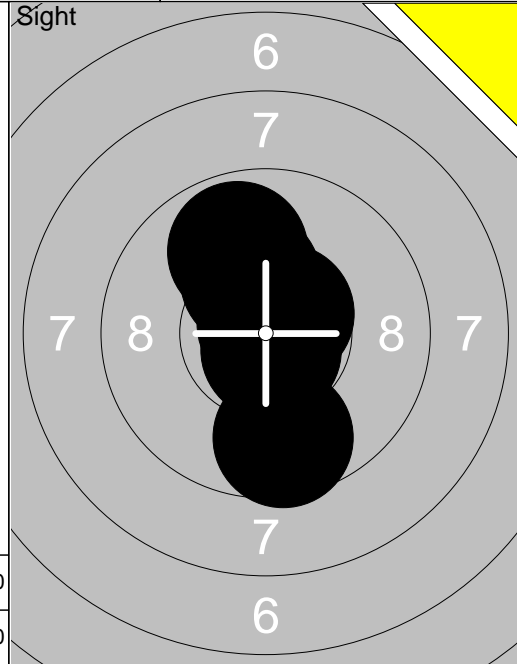

11:	9.6	↓
12:	*10.6	↗
13:	*10.8	↗
14:	9.8	↗
15:	*10.2	↗
16:	*10.7	↓
Series		58.0
Total		0.0

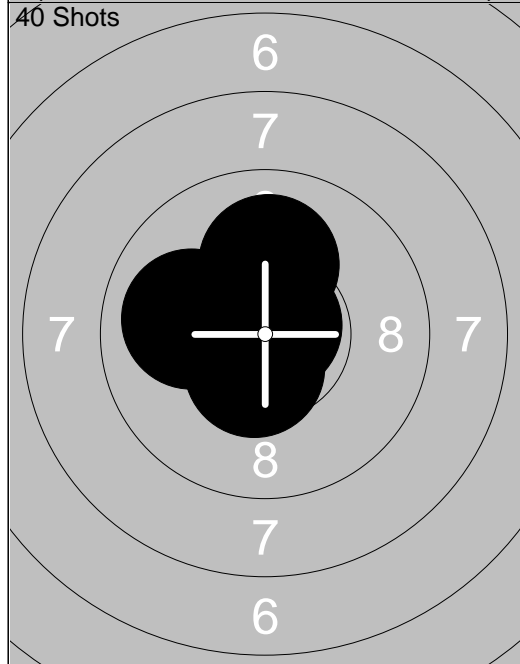

1:	10.1	↑
2:	*10.6	↖
3:	*10.2	←
4:	*10.6	↑
5:	*10.3	←
6:	*10.5	↓
7:	10.0	←
8:	*10.8	←
9:	*10.8	↗
10:	*10.7	↙
Series		100.0
Total		100.0

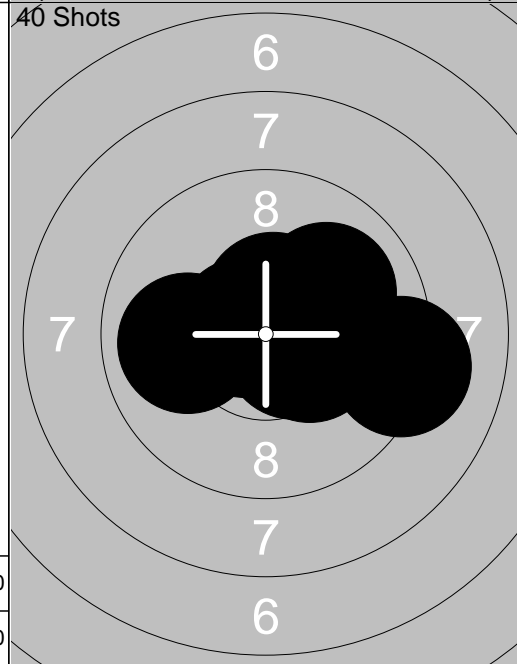

11:	*10.7	↗
12:	*10.7	↖
13:	*10.8	↑
14:	9.9	←
15:	10.0	↗
16:	*10.6	↗
17:	*10.5	↑
18:	*10.3	↘
19:	9.2	→
20:	*10.5	↘
Series		98.0
Total		198.0

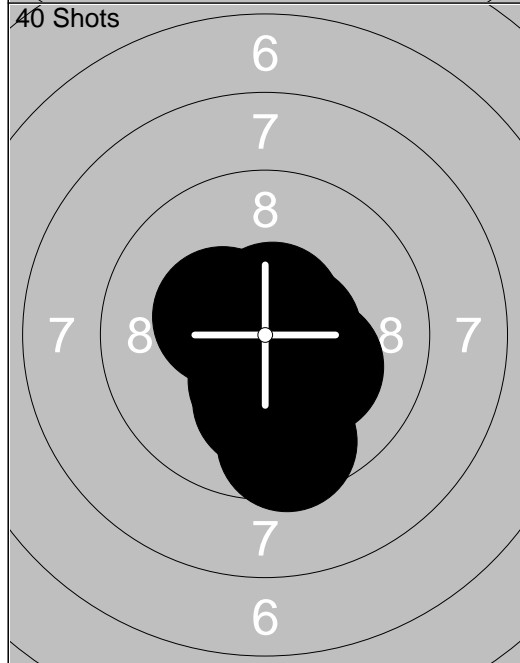

21:	*10.6	↗
22:	*10.4	↖
23:	*10.7	↖
24:	*10.4	↓
25:	*10.4	↓
26:	*10.6	→
27:	10.1	↓
28:	*10.2	↘
29:	*10.7	←
30:	9.6	↓
Series		99.0
Total		297.0

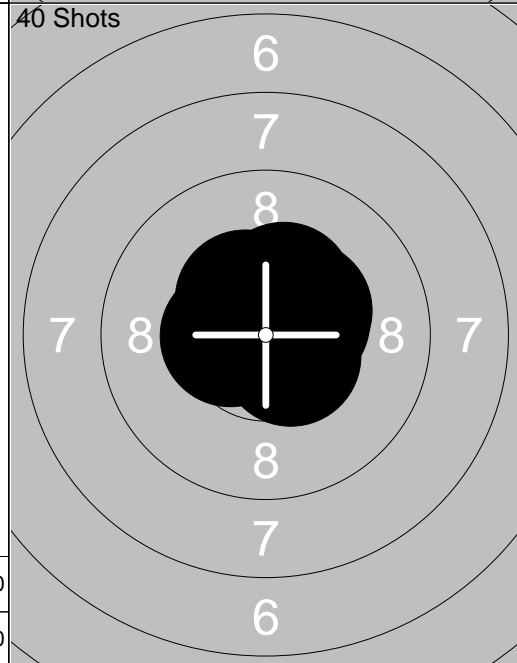

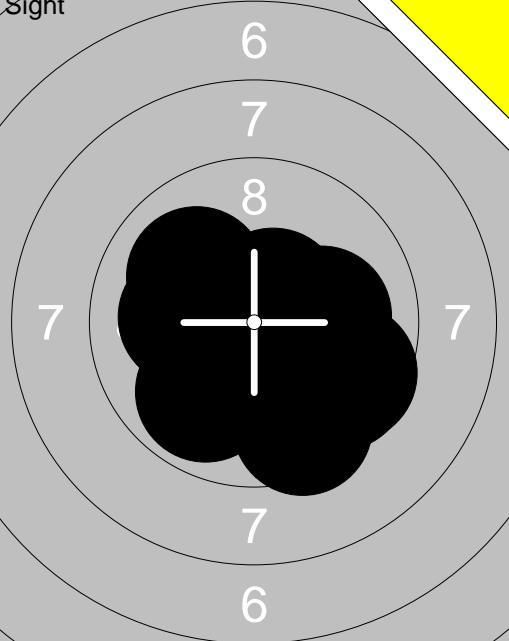
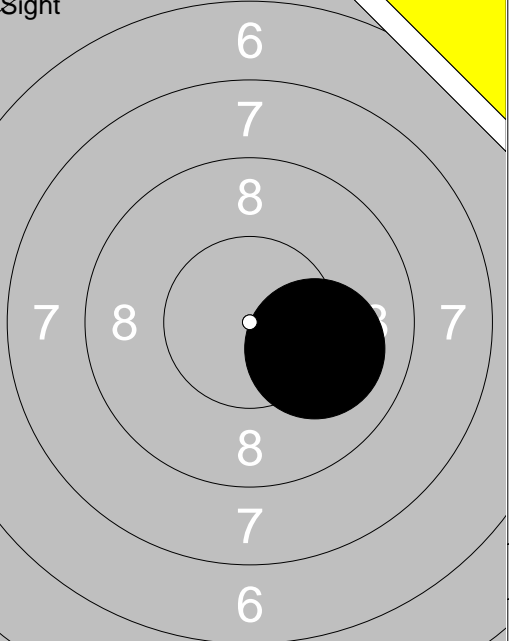

31:	*10.5	↘
32:	*10.6	↗
33:	*10.4	↖
34:	*10.5	↑
35:	*10.4	↗
36:	*10.5	↗
37:	*10.4	↗
38:	*10.7	↗
39:	*10.5	↗
40:	*10.5	←
Series		100.0
Total		397.0

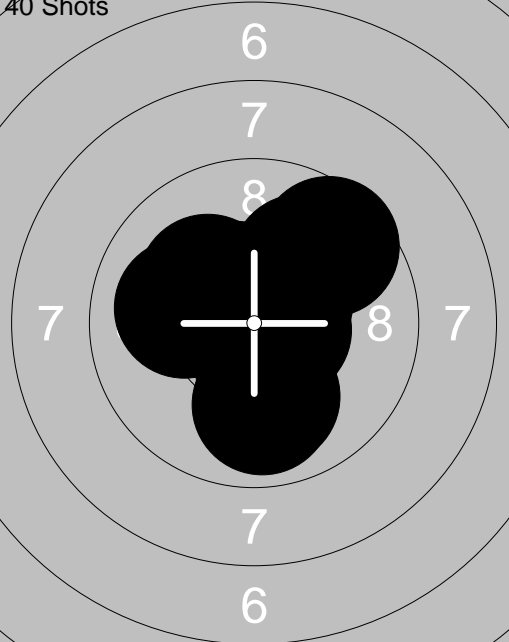
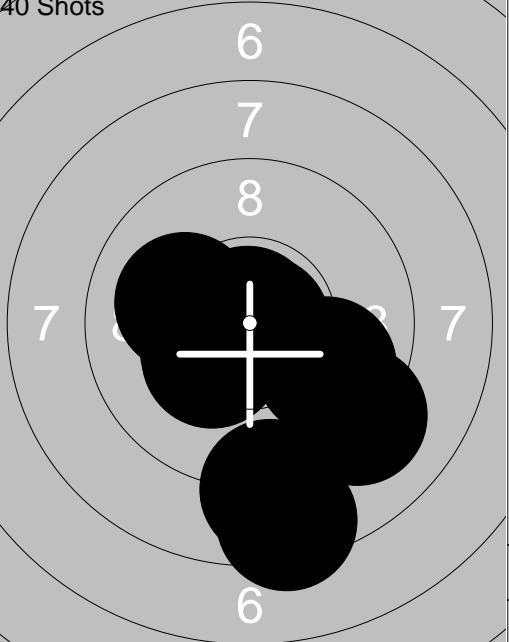
<p>Sight</p> 	<p>1: 10.1 →</p> <p>2: 9.9 ↙</p> <p>3: 10.0 ↖</p> <p>4: 10.1 ←</p> <p>5: 9.5 ↓</p> <p>6: *10.4 ←</p> <p>7: 9.6 →</p> <p>8: 9.6 ↓</p> <p>9: 10.1 →</p> <p>10: *10.6 ↗</p>	<p>Sight</p> 	<p>11: 10.1 →</p>
<p>Series 96.0</p> <p>Total 0.0</p>		<p>Series 10.0</p> <p>Total 0.0</p>	

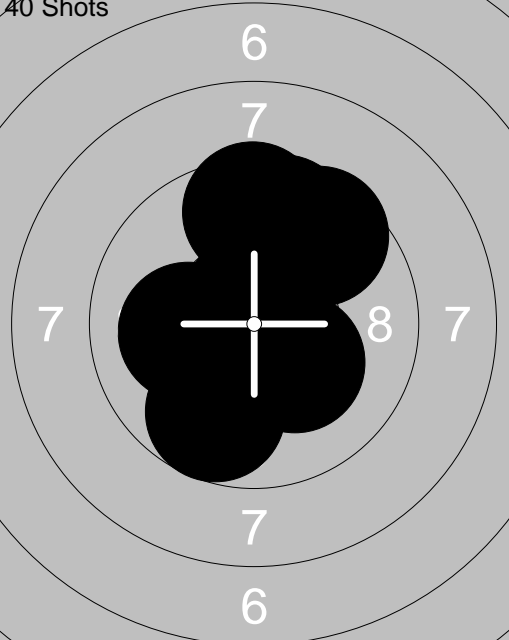
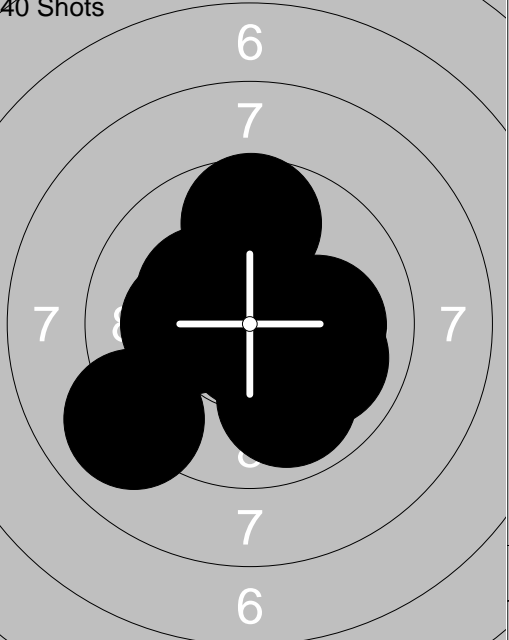
<p>40 Shots</p> 	<p>1: 10.0 ↗</p> <p>2: *10.5 ↗</p> <p>3: *10.6 →</p> <p>4: 10.0 ←</p> <p>5: 9.6 ↗</p> <p>6: *10.5 ↗</p> <p>7: 9.9 ↓</p> <p>8: *10.3 ↓</p> <p>9: 10.0 ↓</p> <p>10: *10.2 ↖</p>	<p>40 Shots</p> 	<p>11: *10.5 ←</p> <p>12: *10.3 ↙</p> <p>13: 10.1 ←</p> <p>14: 9.1 ↓</p> <p>15: *10.9 ↑</p> <p>16: *10.8 →</p> <p>17: *10.3 ↙</p> <p>18: 8.4 ↓</p> <p>19: 8.8 ↓</p> <p>20: 9.8 →</p>
<p>Series 98.0</p> <p>Total 98.0</p>		<p>Series 94.0</p> <p>Total 192.0</p>	

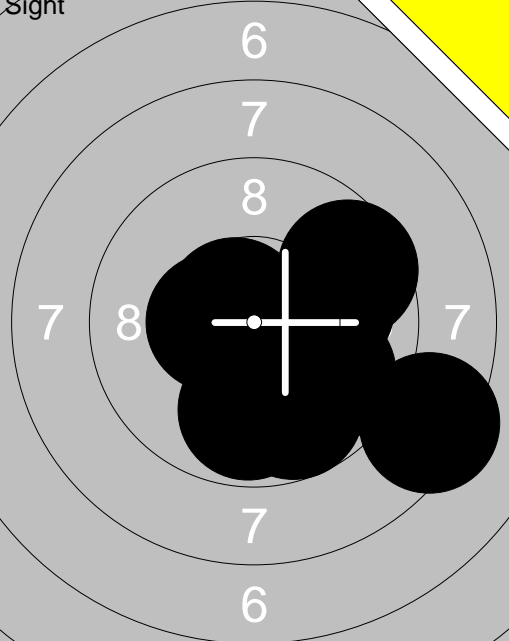
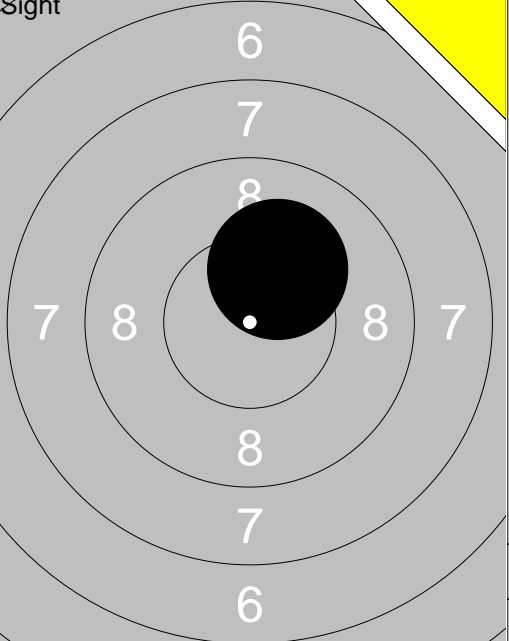
<p>40 Shots</p> 	<p>21: *10.2 ↓</p> <p>22: *10.6 ↓</p> <p>23: 9.5 ↑</p> <p>24: *10.7 ↓</p> <p>25: *10.6 ↑</p> <p>26: *10.6 ↑</p> <p>27: 10.1 ←</p> <p>28: 9.6 ↑</p> <p>29: 9.7 ↓</p> <p>30: 9.6 ↗</p>	<p>40 Shots</p> 	<p>31: 10.0 →</p> <p>32: 10.1 →</p> <p>33: 9.9 ↓</p> <p>34: *10.3 ↖</p> <p>35: 9.7 ↑</p> <p>36: *10.7 ↑</p> <p>37: 9.0 ↙</p> <p>38: *10.7 ←</p> <p>39: *10.2 ←</p> <p>40: *10.7 ↓</p>
<p>Series 96.0</p> <p>Total 288.0</p>		<p>Series 97.0</p> <p>Total 385.0</p>	

<p>Sight</p> 	<p>1: 8.4 →</p> <p>2: 10.0 →</p> <p>3: 9.8 ↓</p> <p>4: *10.8 ←</p> <p>5: 9.8 ↓</p> <p>6: 9.6 →</p> <p>7: *10.5 ←</p> <p>8: 10.1 ↓</p> <p>9: 9.7 ↓</p> <p>10: *10.6 ↖</p>	<p>Sight</p> 	<p>11: *10.2 ↗</p>
Series	94.0	Series	10.0
Total	0.0	Total	0.0

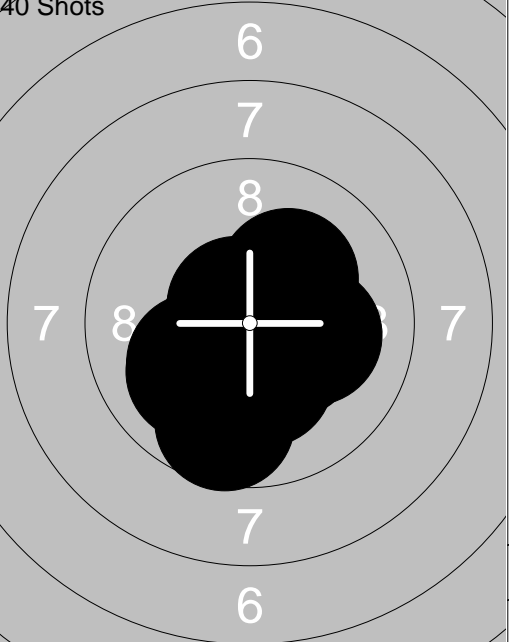
<p>40 Shots</p> 	<p>1: 9.9 →</p> <p>2: *10.7 ↗</p> <p>3: *10.2 ↖</p> <p>4: *10.2 ↓</p> <p>5: *10.6 ↖</p> <p>6: *10.4 ←</p> <p>7: *10.2 ↗</p> <p>8: *10.3 →</p> <p>9: 9.2 ↖</p> <p>10: *10.7 ↗</p>	<p>40 Shots</p> 	<p>11: *10.2 ↗</p> <p>12: 10.0 ↖</p> <p>13: *10.4 ↘</p> <p>14: 9.7 ↓</p> <p>15: *10.2 ↓</p> <p>16: 10.1 ↖</p> <p>17: 10.1 ↓</p> <p>18: 10.1 →</p> <p>19: *10.7 ↗</p> <p>20: *10.4 ↘</p>
Series	98.0	Series	99.0
Total	98.0	Total	197.0

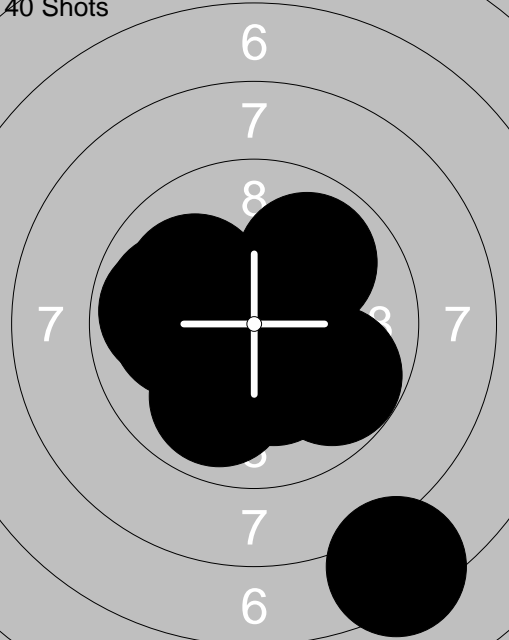
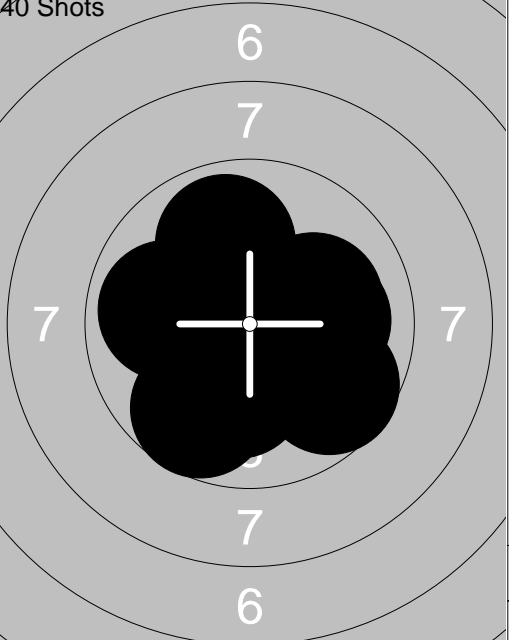
<p>40 Shots</p> 	<p>21: 9.9 ↗</p> <p>22: *10.7 ↖</p> <p>23: 10.0 ↖</p> <p>24: 9.8 ←</p> <p>25: 10.0 ←</p> <p>26: *10.3 ↓</p> <p>27: 9.9 ↓</p> <p>28: 9.8 ↓</p> <p>29: 7.4 ↓</p> <p>30: 9.9 ←</p>	<p>40 Shots</p> 	<p>31: *10.9 →</p> <p>32: 9.7 ↖</p> <p>33: 9.8 ↖</p> <p>34: 9.7 ↘</p> <p>35: 10.1 ↓</p> <p>36: 10.1 →</p> <p>37: *10.7 ↓</p> <p>38: 9.9 ↗</p> <p>39: 10.0 →</p> <p>40: 9.9 ←</p>
Series	92.0	Series	95.0
Total	289.0	Total	384.0

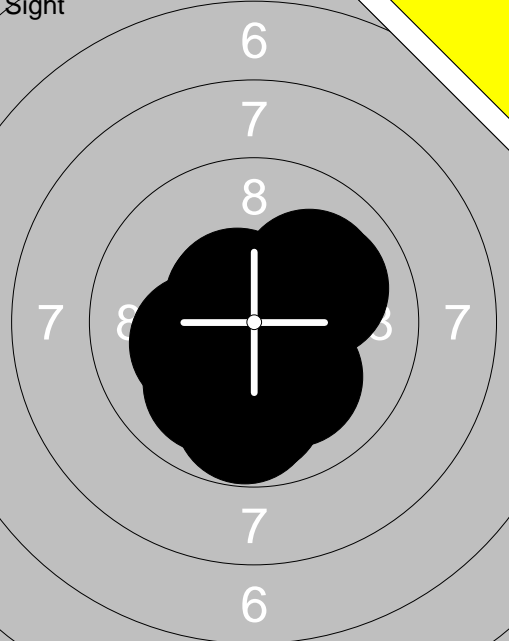
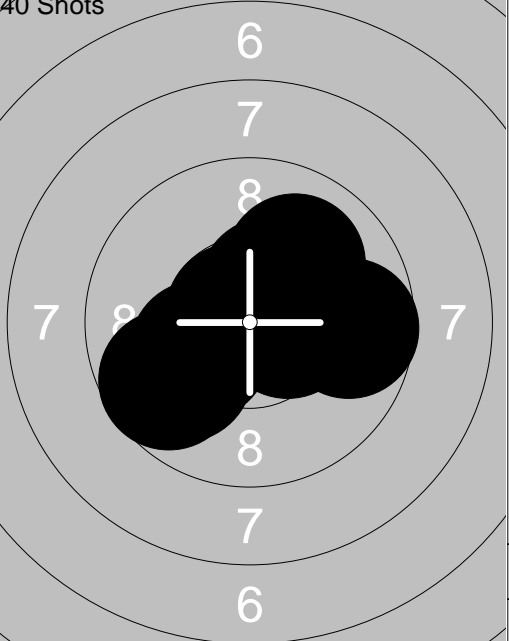
<p>Sight</p> 	<p>40 Shots</p> 	
<p>1: 9.8 ↓</p> <p>2: *10.2 ←</p> <p>3: 10.0 →</p> <p>4: 9.9 ↓</p> <p>5: 10.0 ↓</p> <p>6: *10.6 ↗</p> <p>7: 10.1 ↓</p> <p>8: *10.6 ↗</p> <p>9: 10.1 ↗</p>	<p>1: 9.7 ↙</p> <p>2: 9.7 →</p> <p>3: 9.9 ↙</p> <p>4: *10.2 ↙</p> <p>5: *10.7 ↗</p> <p>6: 10.0 ↗</p> <p>7: *10.7 ↗</p> <p>8: *10.4 ↗</p> <p>9: *10.5 →</p> <p>10: *10.7 ↙</p>	
<p>Series 88.0</p> <p>Total 0.0</p>	<p>Series 97.0</p> <p>Total 97.0</p>	

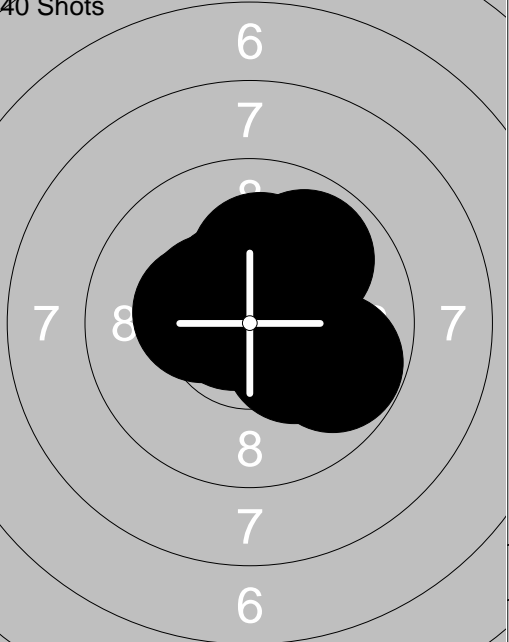
<p>40 Shots</p> 	<p>40 Shots</p> 	
<p>11: *10.5 ↗</p> <p>12: 10.1 →</p> <p>13: *10.3 ↓</p> <p>14: *10.4 ↗</p> <p>15: *10.7 →</p> <p>16: *10.7 ↗</p> <p>17: *10.4 ↗</p> <p>18: *10.4 ↗</p> <p>19: 9.9 ←</p> <p>20: *10.4 ←</p>	<p>21: *10.3 ↘</p> <p>22: *10.5 ↖</p> <p>23: *10.3 ↗</p> <p>24: 9.8 →</p> <p>25: *10.9 ↑</p> <p>26: 9.9 ↗</p> <p>27: *10.3 ←</p> <p>28: *10.2 ↑</p> <p>29: *10.7 ←</p> <p>30: *10.4 ↙</p>	
<p>Series 99.0</p> <p>Total 196.0</p>	<p>Series 98.0</p> <p>Total 294.0</p>	

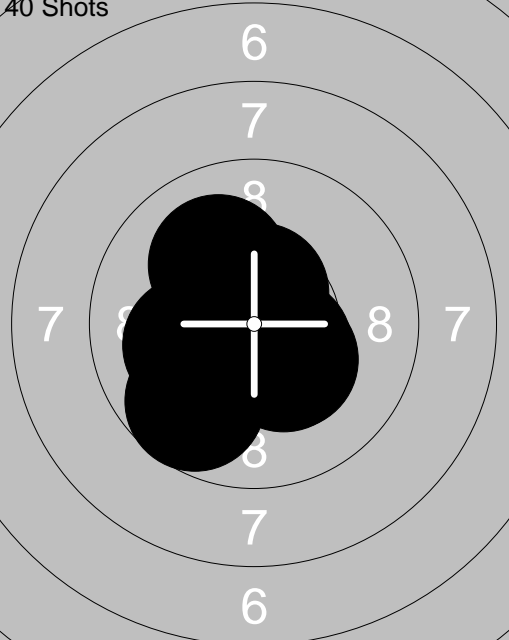
<p>40 Shots</p> 		
<p>31: *10.3 ↓</p> <p>32: 10.1 ←</p> <p>33: *10.7 ↓</p> <p>34: *10.5 ↑</p> <p>35: *10.3 ↓</p> <p>36: 9.7 ↙</p> <p>37: *10.5 ↓</p> <p>38: 10.1 ↗</p> <p>39: *10.6 ↓</p> <p>40: *10.7 ↙</p>		
<p>Series 99.0</p> <p>Total 393.0</p>		

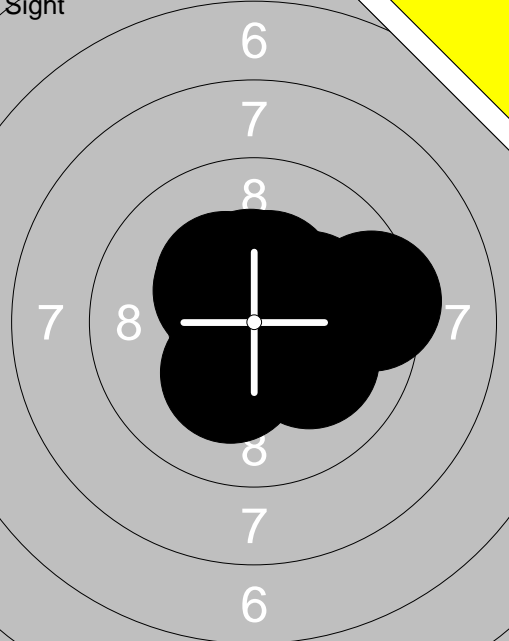
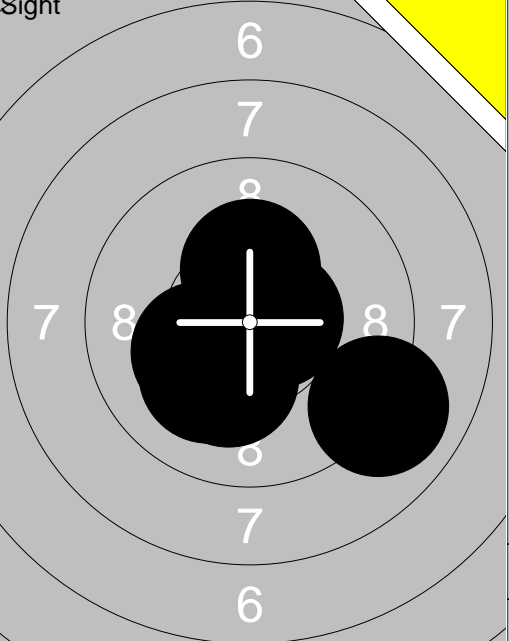
<p>Sight</p> 	<p>1: *10.6 ↘ 2: 9.4 → 3: 10.1 ↘ 4: *10.6 → 5: *10.3 ↗ 6: *10.2 → 7: *10.4 ↑ 8: *10.4 ↗ 9: *10.4 ↑ 10: *10.2 ↘</p> <table border="1" style="width:100%; border-collapse: collapse;"> <tr><td>Series</td><td style="text-align: right;">99.0</td></tr> <tr><td>Total</td><td style="text-align: right;">0.0</td></tr> </table>	Series	99.0	Total	0.0	<p>Sight</p> 	<p>11: 9.0 → 12: *10.2 ↘ 13: 10.1 ↘ 14: *10.3 ↑ 15: *10.6 → 16: *10.2 ↙</p> <table border="1" style="width:100%; border-collapse: collapse;"> <tr><td>Series</td><td style="text-align: right;">59.0</td></tr> <tr><td>Total</td><td style="text-align: right;">0.0</td></tr> </table>	Series	59.0	Total	0.0
Series	99.0										
Total	0.0										
Series	59.0										
Total	0.0										

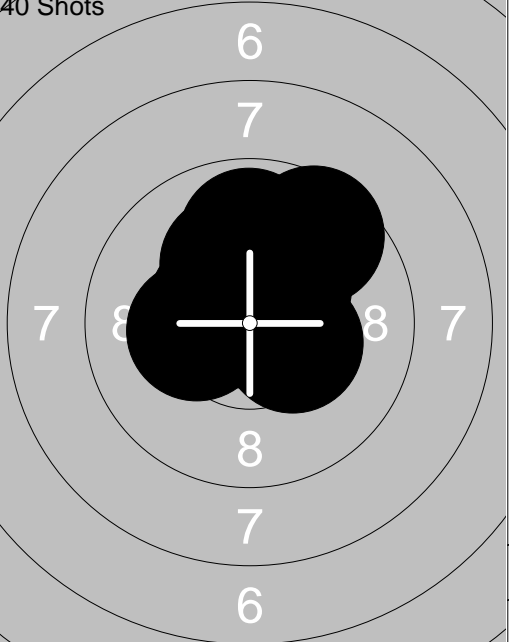
<p>40 Shots</p> 	<p>1: *10.4 ↑ 2: 9.9 ↙ 3: 10.1 → 4: *10.5 ↘ 5: 9.5 ↑ 6: 10.1 ↘ 7: *10.3 ↙ 8: 9.9 ↗ 9: 10.1 ↑ 10: *10.5 ↘</p> <table border="1" style="width:100%; border-collapse: collapse;"> <tr><td>Series</td><td style="text-align: right;">97.0</td></tr> <tr><td>Total</td><td style="text-align: right;">97.0</td></tr> </table>	Series	97.0	Total	97.0	<p>40 Shots</p> 	<p>11: 9.6 ↗ 12: *10.6 ↙ 13: *10.5 ↗ 14: *10.5 ↙ 15: 9.9 ↑ 16: *10.3 → 17: *10.3 ← 18: *10.2 ↑ 19: *10.8 ↙ 20: *10.3 ↗</p> <table border="1" style="width:100%; border-collapse: collapse;"> <tr><td>Series</td><td style="text-align: right;">98.0</td></tr> <tr><td>Total</td><td style="text-align: right;">195.0</td></tr> </table>	Series	98.0	Total	195.0
Series	97.0										
Total	97.0										
Series	98.0										
Total	195.0										

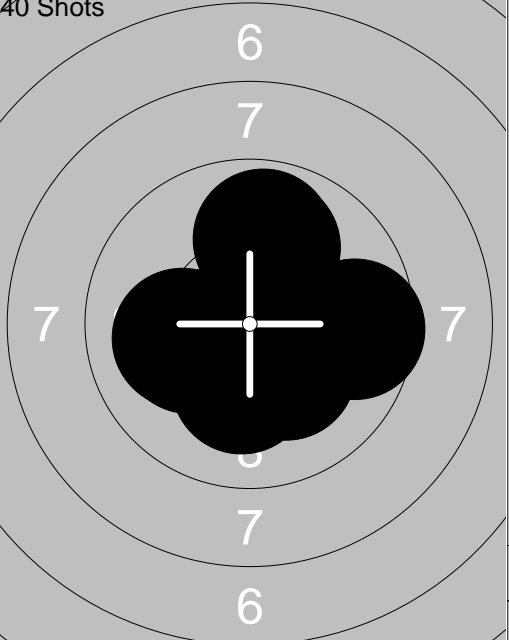
<p>40 Shots</p> 	<p>21: 9.9 ↘ 22: *10.3 ← 23: 9.6 → 24: *10.7 ← 25: *10.3 ↑ 26: 10.0 ↙ 27: 9.9 ↙ 28: *10.2 ↘ 29: *10.7 → 30: *10.3 ↘</p> <table border="1" style="width:100%; border-collapse: collapse;"> <tr><td>Series</td><td style="text-align: right;">97.0</td></tr> <tr><td>Total</td><td style="text-align: right;">292.0</td></tr> </table>	Series	97.0	Total	292.0	<p>40 Shots</p> 	<p>31: *10.5 ← 32: *10.2 ↘ 33: 9.9 ↑ 34: *10.6 → 35: 9.9 ↑ 36: 10.1 ← 37: 9.6 → 38: *10.2 ↘ 39: *10.2 ↘ 40: *10.2 ←</p> <table border="1" style="width:100%; border-collapse: collapse;"> <tr><td>Series</td><td style="text-align: right;">97.0</td></tr> <tr><td>Total</td><td style="text-align: right;">389.0</td></tr> </table>	Series	97.0	Total	389.0
Series	97.0										
Total	292.0										
Series	97.0										
Total	389.0										

<p>Sight</p>	<p>1: *10.2 →</p> <p>2: *10.9 ↘</p> <p>3: 8.6 ↘</p> <p>4: 9.3 ↘</p> <p>5: *10.6 →</p> <p>6: 9.8 ↘</p> <p>7: *10.7 →</p> <p>8: 10.1 ←</p> <p>9: *10.2 ↑</p> <p>10: 10.0 →</p>	<p>Sight</p>	<p>11: *10.9 ↗</p> <p>12: *10.6 ↖</p> <p>13: *10.6 ↑</p>
Series 96.0		Series 30.0	
Total 0.0		Total 0.0	

<p>40 Shots</p>	<p>1: *10.7 ↖</p> <p>2: *10.6 →</p> <p>3: *10.8 ↑</p> <p>4: 10.1 ↘</p> <p>5: *10.3 ↘</p> <p>6: *10.3 ↗</p> <p>7: *10.7 ↗</p> <p>8: *10.4 ↘</p> <p>9: *10.5 →</p> <p>10: *10.6 ↘</p>	<p>40 Shots</p>	<p>11: *10.5 ↖</p> <p>12: 10.0 ↖</p> <p>13: *10.5 ↗</p> <p>14: *10.6 →</p> <p>15: *10.7 ←</p> <p>16: *10.4 ↗</p> <p>17: 9.6 ↘</p> <p>18: *10.7 ←</p> <p>19: *10.7 →</p> <p>20: 9.8 ↖</p>
Series 100.0		Series 98.0	
Total 100.0		Total 198.0	

<p>40 Shots</p>	<p>21: *10.9 ↑</p> <p>22: *10.2 ↑</p> <p>23: *10.4 ↗</p> <p>24: *10.2 ↘</p> <p>25: 9.9 ↘</p> <p>26: *10.4 →</p> <p>27: *10.9 ↘</p> <p>28: 10.1 ↗</p> <p>29: *10.2 ↖</p> <p>30: *10.3 ↖</p>	<p>40 Shots</p>	<p>31: *10.5 ↖</p> <p>32: *10.6 ↗</p> <p>33: 10.1 ←</p> <p>34: *10.4 ↗</p> <p>35: 10.0 ←</p> <p>36: *10.3 ↑</p> <p>37: *10.7 ↖</p> <p>38: *10.4 ↘</p> <p>39: *10.7 ↑</p> <p>40: *10.6 ↘</p>
Series 99.0		Series 100.0	
Total 297.0		Total 397.0	

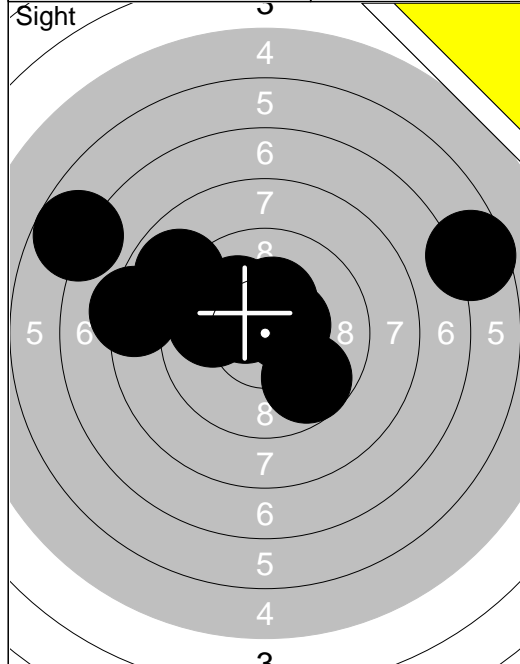

1:	*10.3	↗
2:	6.6	→
3:	9.7	↘
4:	9.9	←
5:	8.9	↗
6:	*10.5	↗
7:	6.8	↗
8:	*10.5	→
9:	8.3	←
10:	10.1	↗
Series		86.0
Total		0.0

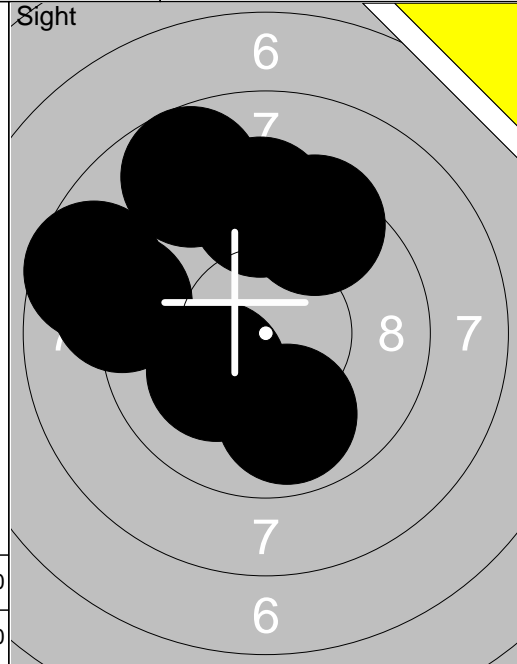

11:	8.6	↖
12:	9.3	↑
13:	*10.2	↙
14:	9.4	↗
15:	8.7	↗
16:	9.1	↖
17:	9.9	↘
Series		62.0
Total		0.0

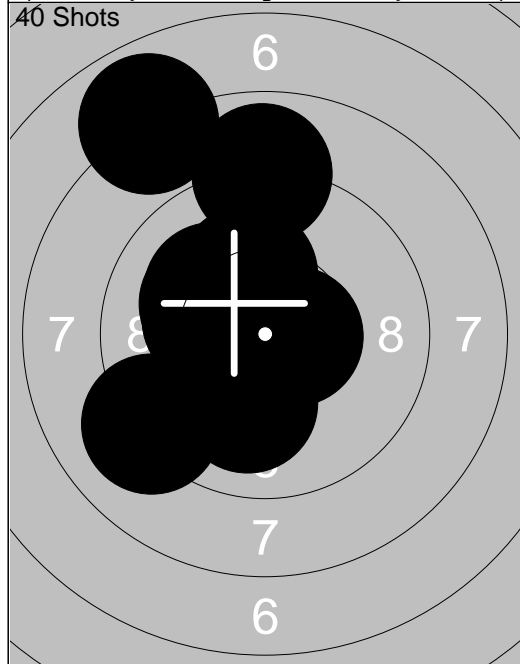

1:	8.9	↑
2:	*10.2	↑
3:	9.1	↖
4:	*10.5	↘
5:	10.0	↘
6:	*10.6	→
7:	10.1	↗
8:	*10.2	←
9:	10.1	↖
10:	7.9	↗
Series		94.0
Total		94.0

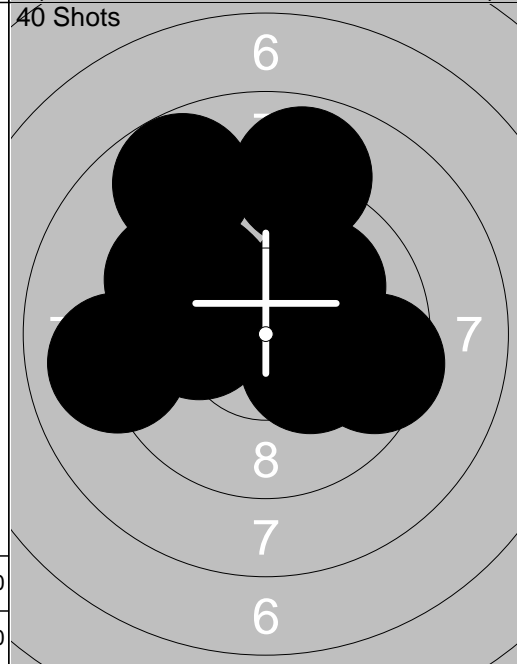

11:	10.1	↗
12:	8.9	↑
13:	9.0	↖
14:	10.1	↖
15:	10.0	↗
16:	9.9	↗
17:	8.8	↗
18:	9.6	↗
19:	9.5	→
20:	*10.3	↘
Series		92.0
Total		186.0

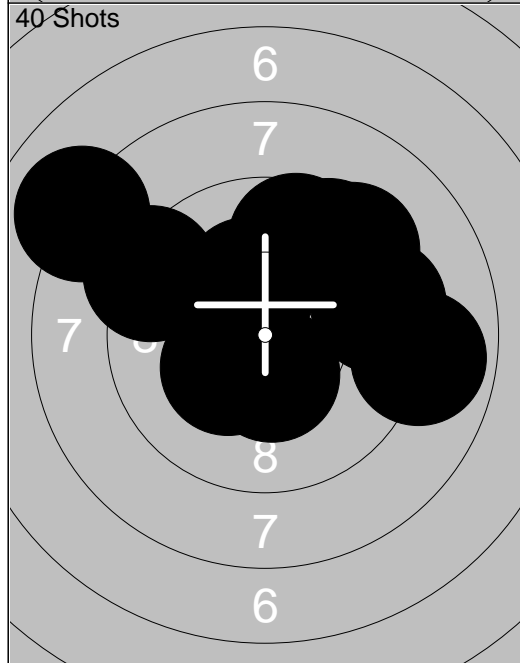

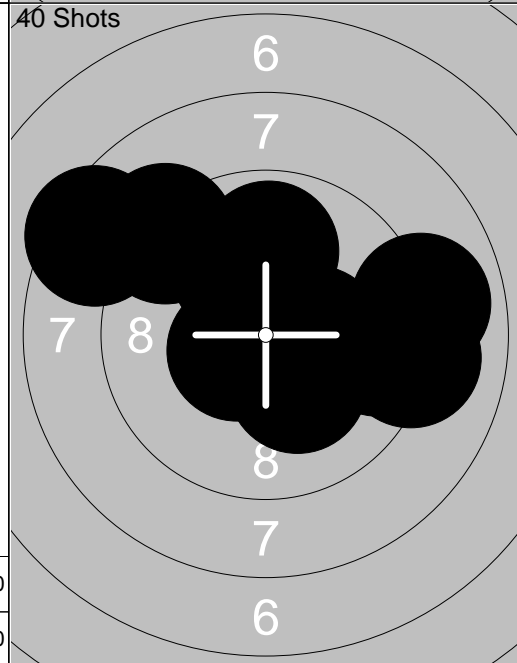

21:	*10.3	↑
22:	9.4	→
23:	9.5	↗
24:	8.9	→
25:	*10.4	↘
26:	9.3	↗
27:	*10.3	↖
28:	9.2	←
29:	8.0	↖
30:	9.6	↗
Series		91.0
Total		277.0

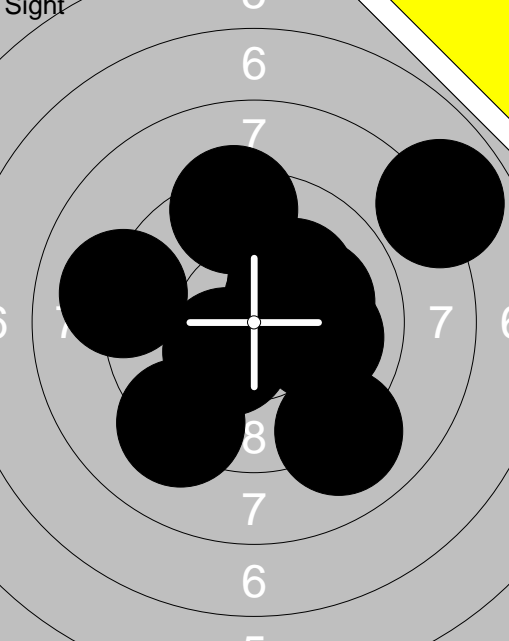
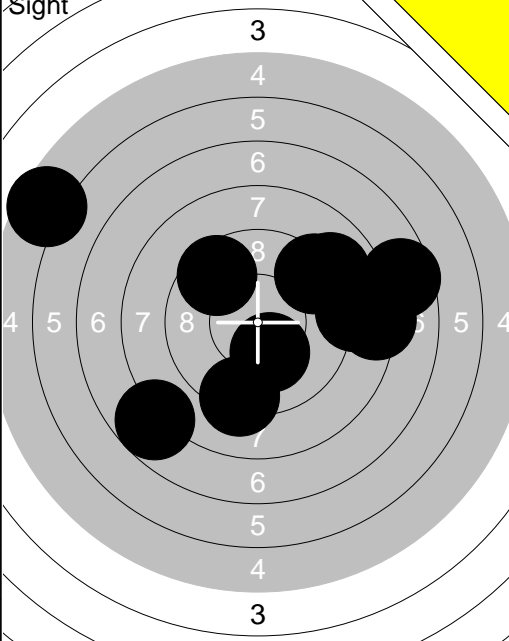

31:	*10.5	↖
32:	9.1	↗
33:	10.1	↗
34:	*10.2	↘
35:	*10.3	→
36:	9.1	→
37:	8.4	↖
38:	9.5	→
39:	9.9	↑
40:	8.9	→
Series		92.0
Total		369.0

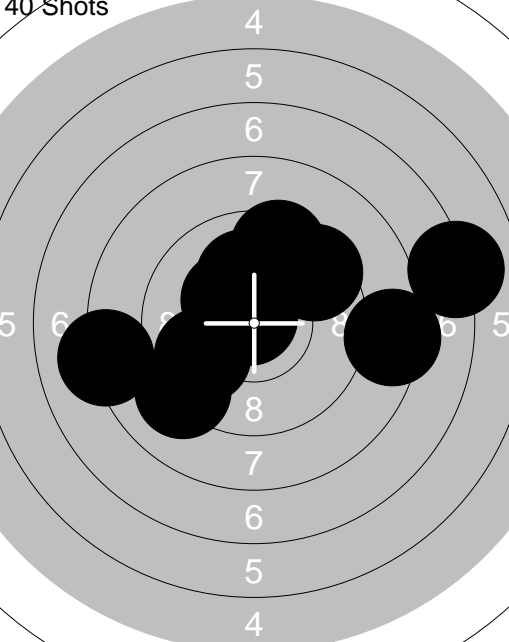
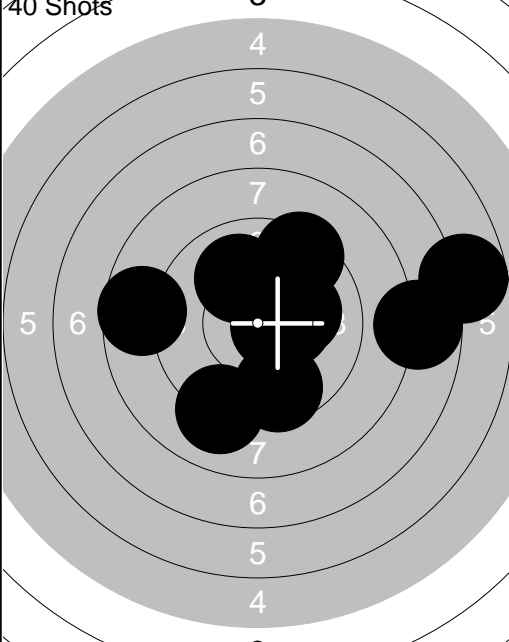
	<p>Sight</p> <table style="width:100%; border-collapse: collapse;"> <tr><td>1:</td><td>*10.4</td><td>↙</td></tr> <tr><td>2:</td><td>9.2</td><td>↙</td></tr> <tr><td>3:</td><td>9.1</td><td>←</td></tr> <tr><td>4:</td><td>10.1</td><td>→</td></tr> <tr><td>5:</td><td>*10.2</td><td>↗</td></tr> <tr><td>6:</td><td>9.0</td><td>↘</td></tr> <tr><td>7:</td><td>10.0</td><td>→</td></tr> <tr><td>8:</td><td>9.4</td><td>↑</td></tr> <tr><td>9:</td><td>*10.4</td><td>↗</td></tr> <tr><td>10:</td><td>7.9</td><td>↗</td></tr> </table> <table style="width:100%; border-collapse: collapse;"> <tr><td>Series</td><td style="text-align: right;">93.0</td></tr> <tr><td>Total</td><td style="text-align: right;">0.0</td></tr> </table>	1:	*10.4	↙	2:	9.2	↙	3:	9.1	←	4:	10.1	→	5:	*10.2	↗	6:	9.0	↘	7:	10.0	→	8:	9.4	↑	9:	*10.4	↗	10:	7.9	↗	Series	93.0	Total	0.0		<p>Sight</p> <table style="width:100%; border-collapse: collapse;"> <tr><td>11:</td><td>9.3</td><td>↗</td></tr> <tr><td>12:</td><td>5.5</td><td>↖</td></tr> <tr><td>13:</td><td>7.6</td><td>→</td></tr> <tr><td>14:</td><td>9.5</td><td>↖</td></tr> <tr><td>15:</td><td>*10.2</td><td>↘</td></tr> <tr><td>16:</td><td>8.3</td><td>→</td></tr> <tr><td>17:</td><td>8.7</td><td>→</td></tr> <tr><td>18:</td><td>7.7</td><td>↘</td></tr> <tr><td>19:</td><td>9.2</td><td>↘</td></tr> <tr><td>20:</td><td>9.0</td><td>↗</td></tr> </table> <table style="width:100%; border-collapse: collapse;"> <tr><td>Series</td><td style="text-align: right;">81.0</td></tr> <tr><td>Total</td><td style="text-align: right;">0.0</td></tr> </table>	11:	9.3	↗	12:	5.5	↖	13:	7.6	→	14:	9.5	↖	15:	*10.2	↘	16:	8.3	→	17:	8.7	→	18:	7.7	↘	19:	9.2	↘	20:	9.0	↗	Series	81.0	Total	0.0
1:	*10.4	↙																																																																					
2:	9.2	↙																																																																					
3:	9.1	←																																																																					
4:	10.1	→																																																																					
5:	*10.2	↗																																																																					
6:	9.0	↘																																																																					
7:	10.0	→																																																																					
8:	9.4	↑																																																																					
9:	*10.4	↗																																																																					
10:	7.9	↗																																																																					
Series	93.0																																																																						
Total	0.0																																																																						
11:	9.3	↗																																																																					
12:	5.5	↖																																																																					
13:	7.6	→																																																																					
14:	9.5	↖																																																																					
15:	*10.2	↘																																																																					
16:	8.3	→																																																																					
17:	8.7	→																																																																					
18:	7.7	↘																																																																					
19:	9.2	↘																																																																					
20:	9.0	↗																																																																					
Series	81.0																																																																						
Total	0.0																																																																						

	<p>40 Shots</p> <table style="width:100%; border-collapse: collapse;"> <tr><td>1:</td><td>10.1</td><td>↑</td></tr> <tr><td>2:</td><td>9.5</td><td>↗</td></tr> <tr><td>3:</td><td>8.4</td><td>→</td></tr> <tr><td>4:</td><td>9.8</td><td>↖</td></tr> <tr><td>5:</td><td>9.5</td><td>↑</td></tr> <tr><td>6:</td><td>7.1</td><td>→</td></tr> <tr><td>7:</td><td>*10.8</td><td>↗</td></tr> <tr><td>8:</td><td>8.1</td><td>←</td></tr> <tr><td>9:</td><td>*10.3</td><td>↖</td></tr> <tr><td>10:</td><td>9.1</td><td>↘</td></tr> </table> <table style="width:100%; border-collapse: collapse;"> <tr><td>Series</td><td style="text-align: right;">89.0</td></tr> <tr><td>Total</td><td style="text-align: right;">89.0</td></tr> </table>	1:	10.1	↑	2:	9.5	↗	3:	8.4	→	4:	9.8	↖	5:	9.5	↑	6:	7.1	→	7:	*10.8	↗	8:	8.1	←	9:	*10.3	↖	10:	9.1	↘	Series	89.0	Total	89.0		<p>40 Shots</p> <table style="width:100%; border-collapse: collapse;"> <tr><td>11:</td><td>*10.6</td><td>→</td></tr> <tr><td>12:</td><td>*10.4</td><td>→</td></tr> <tr><td>13:</td><td>9.4</td><td>↗</td></tr> <tr><td>14:</td><td>9.1</td><td>↘</td></tr> <tr><td>15:</td><td>8.6</td><td>←</td></tr> <tr><td>16:</td><td>7.7</td><td>→</td></tr> <tr><td>17:</td><td>10.1</td><td>→</td></tr> <tr><td>18:</td><td>9.6</td><td>↘</td></tr> <tr><td>19:</td><td>6.7</td><td>→</td></tr> <tr><td>20:</td><td>10.0</td><td>↖</td></tr> </table> <table style="width:100%; border-collapse: collapse;"> <tr><td>Series</td><td style="text-align: right;">88.0</td></tr> <tr><td>Total</td><td style="text-align: right;">177.0</td></tr> </table>	11:	*10.6	→	12:	*10.4	→	13:	9.4	↗	14:	9.1	↘	15:	8.6	←	16:	7.7	→	17:	10.1	→	18:	9.6	↘	19:	6.7	→	20:	10.0	↖	Series	88.0	Total	177.0
1:	10.1	↑																																																																					
2:	9.5	↗																																																																					
3:	8.4	→																																																																					
4:	9.8	↖																																																																					
5:	9.5	↑																																																																					
6:	7.1	→																																																																					
7:	*10.8	↗																																																																					
8:	8.1	←																																																																					
9:	*10.3	↖																																																																					
10:	9.1	↘																																																																					
Series	89.0																																																																						
Total	89.0																																																																						
11:	*10.6	→																																																																					
12:	*10.4	→																																																																					
13:	9.4	↗																																																																					
14:	9.1	↘																																																																					
15:	8.6	←																																																																					
16:	7.7	→																																																																					
17:	10.1	→																																																																					
18:	9.6	↘																																																																					
19:	6.7	→																																																																					
20:	10.0	↖																																																																					
Series	88.0																																																																						
Total	177.0																																																																						

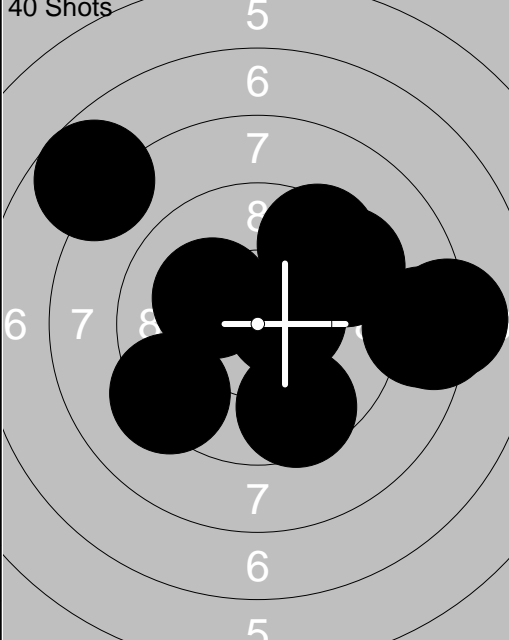
	<p>40 Shots</p> <table style="width:100%; border-collapse: collapse;"> <tr><td>21:</td><td>8.9</td><td>↗</td></tr> <tr><td>22:</td><td>9.0</td><td>↑</td></tr> <tr><td>23:</td><td>9.9</td><td>←</td></tr> <tr><td>24:</td><td>9.8</td><td>↖</td></tr> <tr><td>25:</td><td>9.7</td><td>↖</td></tr> <tr><td>26:</td><td>10.0</td><td>→</td></tr> <tr><td>27:</td><td>*10.5</td><td>←</td></tr> <tr><td>28:</td><td>9.8</td><td>↘</td></tr> <tr><td>29:</td><td>*10.3</td><td>↗</td></tr> <tr><td>30:</td><td>6.9</td><td>←</td></tr> </table> <table style="width:100%; border-collapse: collapse;"> <tr><td>Series</td><td style="text-align: right;">89.0</td></tr> <tr><td>Total</td><td style="text-align: right;">266.0</td></tr> </table>	21:	8.9	↗	22:	9.0	↑	23:	9.9	←	24:	9.8	↖	25:	9.7	↖	26:	10.0	→	27:	*10.5	←	28:	9.8	↘	29:	*10.3	↗	30:	6.9	←	Series	89.0	Total	266.0		<p>40 Shots</p> <table style="width:100%; border-collapse: collapse;"> <tr><td>31:</td><td>*10.2</td><td>↖</td></tr> <tr><td>32:</td><td>*10.5</td><td>→</td></tr> <tr><td>33:</td><td>9.5</td><td>↗</td></tr> <tr><td>34:</td><td>8.3</td><td>→</td></tr> <tr><td>35:</td><td>7.7</td><td>↖</td></tr> <tr><td>36:</td><td>9.4</td><td>↗</td></tr> <tr><td>37:</td><td>9.3</td><td>↖</td></tr> <tr><td>38:</td><td>9.6</td><td>↘</td></tr> <tr><td>39:</td><td>8.1</td><td>→</td></tr> <tr><td>40:</td><td>8.5</td><td>→</td></tr> </table> <table style="width:100%; border-collapse: collapse;"> <tr><td>Series</td><td style="text-align: right;">87.0</td></tr> <tr><td>Total</td><td style="text-align: right;">353.0</td></tr> </table>	31:	*10.2	↖	32:	*10.5	→	33:	9.5	↗	34:	8.3	→	35:	7.7	↖	36:	9.4	↗	37:	9.3	↖	38:	9.6	↘	39:	8.1	→	40:	8.5	→	Series	87.0	Total	353.0
21:	8.9	↗																																																																					
22:	9.0	↑																																																																					
23:	9.9	←																																																																					
24:	9.8	↖																																																																					
25:	9.7	↖																																																																					
26:	10.0	→																																																																					
27:	*10.5	←																																																																					
28:	9.8	↘																																																																					
29:	*10.3	↗																																																																					
30:	6.9	←																																																																					
Series	89.0																																																																						
Total	266.0																																																																						
31:	*10.2	↖																																																																					
32:	*10.5	→																																																																					
33:	9.5	↗																																																																					
34:	8.3	→																																																																					
35:	7.7	↖																																																																					
36:	9.4	↗																																																																					
37:	9.3	↖																																																																					
38:	9.6	↘																																																																					
39:	8.1	→																																																																					
40:	8.5	→																																																																					
Series	87.0																																																																						
Total	353.0																																																																						

<p>Sight</p>	<p>Sight</p>	<table border="1" style="width:100%; border-collapse: collapse;"> <tr><td>1:</td><td>3.2</td><td>↓</td></tr> <tr><td>2:</td><td>5.3</td><td>↓</td></tr> <tr><td>3:</td><td>1.6</td><td>↓</td></tr> <tr><td>4:</td><td>5.4</td><td>↓</td></tr> <tr><td>5:</td><td>7.7</td><td>↓</td></tr> <tr><td>6:</td><td>5.2</td><td>↓</td></tr> <tr><td>7:</td><td>8.2</td><td>↓</td></tr> <tr><td>8:</td><td>*10.6</td><td>↓</td></tr> <tr><td>9:</td><td>8.1</td><td>←</td></tr> <tr><td>10:</td><td>10.1</td><td>↓</td></tr> <tr><td colspan="2">Series</td><td>62.0</td></tr> <tr><td colspan="2">Total</td><td>0.0</td></tr> </table>	1:	3.2	↓	2:	5.3	↓	3:	1.6	↓	4:	5.4	↓	5:	7.7	↓	6:	5.2	↓	7:	8.2	↓	8:	*10.6	↓	9:	8.1	←	10:	10.1	↓	Series		62.0	Total		0.0
1:	3.2	↓																																				
2:	5.3	↓																																				
3:	1.6	↓																																				
4:	5.4	↓																																				
5:	7.7	↓																																				
6:	5.2	↓																																				
7:	8.2	↓																																				
8:	*10.6	↓																																				
9:	8.1	←																																				
10:	10.1	↓																																				
Series		62.0																																				
Total		0.0																																				

<p>Sight</p>	<p>40 Shots</p>	<table border="1" style="width:100%; border-collapse: collapse;"> <tr><td>11:</td><td>8.2</td><td>↘</td></tr> <tr><td>12:</td><td>8.3</td><td>←</td></tr> <tr><td>13:</td><td>9.3</td><td>↓</td></tr> <tr><td>14:</td><td>5.9</td><td>←</td></tr> <tr><td>15:</td><td>8.2</td><td>↗</td></tr> <tr><td>16:</td><td>9.7</td><td>←</td></tr> <tr><td>17:</td><td>6.6</td><td>↖</td></tr> <tr><td>18:</td><td>8.1</td><td>↓</td></tr> <tr><td>19:</td><td>9.2</td><td>↓</td></tr> <tr><td>20:</td><td>8.3</td><td>←</td></tr> <tr><td colspan="2">Series</td><td>78.0</td></tr> <tr><td colspan="2">Total</td><td>0.0</td></tr> </table>	11:	8.2	↘	12:	8.3	←	13:	9.3	↓	14:	5.9	←	15:	8.2	↗	16:	9.7	←	17:	6.6	↖	18:	8.1	↓	19:	9.2	↓	20:	8.3	←	Series		78.0	Total		0.0
11:	8.2	↘																																				
12:	8.3	←																																				
13:	9.3	↓																																				
14:	5.9	←																																				
15:	8.2	↗																																				
16:	9.7	←																																				
17:	6.6	↖																																				
18:	8.1	↓																																				
19:	9.2	↓																																				
20:	8.3	←																																				
Series		78.0																																				
Total		0.0																																				
<p>Sight</p>	<p>40 Shots</p>	<table border="1" style="width:100%; border-collapse: collapse;"> <tr><td>21:</td><td>8.9</td><td>↘</td></tr> <tr><td>22:</td><td>*10.6</td><td>↙</td></tr> <tr><td colspan="2">Series</td><td>18.0</td></tr> <tr><td colspan="2">Total</td><td>0.0</td></tr> </table>	21:	8.9	↘	22:	*10.6	↙	Series		18.0	Total		0.0																								
21:	8.9	↘																																				
22:	*10.6	↙																																				
Series		18.0																																				
Total		0.0																																				

<p>40 Shots</p>	<p>40 Shots</p>	<table border="1" style="width:100%; border-collapse: collapse;"> <tr><td>11:</td><td>*10.8</td><td>↗</td></tr> <tr><td>12:</td><td>7.3</td><td>←</td></tr> <tr><td>13:</td><td>8.9</td><td>↙</td></tr> <tr><td>14:</td><td>9.3</td><td>→</td></tr> <tr><td>15:</td><td>8.3</td><td>←</td></tr> <tr><td>16:</td><td>10.1</td><td>→</td></tr> <tr><td>17:</td><td>9.6</td><td>↗</td></tr> <tr><td>18:</td><td>9.0</td><td>↙</td></tr> <tr><td>19:</td><td>9.4</td><td>↗</td></tr> <tr><td>20:</td><td>7.0</td><td>←</td></tr> <tr><td colspan="2">Series</td><td>86.0</td></tr> <tr><td colspan="2">Total</td><td>171.0</td></tr> </table>	11:	*10.8	↗	12:	7.3	←	13:	8.9	↙	14:	9.3	→	15:	8.3	←	16:	10.1	→	17:	9.6	↗	18:	9.0	↙	19:	9.4	↗	20:	7.0	←	Series		86.0	Total		171.0
11:	*10.8	↗																																				
12:	7.3	←																																				
13:	8.9	↙																																				
14:	9.3	→																																				
15:	8.3	←																																				
16:	10.1	→																																				
17:	9.6	↗																																				
18:	9.0	↙																																				
19:	9.4	↗																																				
20:	7.0	←																																				
Series		86.0																																				
Total		171.0																																				
<p>40 Shots</p>	<p>40 Shots</p>	<table border="1" style="width:100%; border-collapse: collapse;"> <tr><td>21:</td><td>8.6</td><td>↙</td></tr> <tr><td>22:</td><td>7.7</td><td>↖</td></tr> <tr><td>23:</td><td>7.0</td><td>←</td></tr> <tr><td>24:</td><td>9.1</td><td>↗</td></tr> <tr><td>25:</td><td>6.9</td><td>←</td></tr> <tr><td>26:</td><td>*10.3</td><td>↗</td></tr> <tr><td>27:</td><td>9.1</td><td>↘</td></tr> <tr><td>28:</td><td>6.5</td><td>←</td></tr> <tr><td>29:</td><td>9.1</td><td>←</td></tr> <tr><td>30:</td><td>*10.3</td><td>↖</td></tr> <tr><td colspan="2">Series</td><td>81.0</td></tr> <tr><td colspan="2">Total</td><td>252.0</td></tr> </table>	21:	8.6	↙	22:	7.7	↖	23:	7.0	←	24:	9.1	↗	25:	6.9	←	26:	*10.3	↗	27:	9.1	↘	28:	6.5	←	29:	9.1	←	30:	*10.3	↖	Series		81.0	Total		252.0
21:	8.6	↙																																				
22:	7.7	↖																																				
23:	7.0	←																																				
24:	9.1	↗																																				
25:	6.9	←																																				
26:	*10.3	↗																																				
27:	9.1	↘																																				
28:	6.5	←																																				
29:	9.1	←																																				
30:	*10.3	↖																																				
Series		81.0																																				
Total		252.0																																				

<p>40 Shots</p>	<table border="1" style="width:100%; border-collapse: collapse;"> <tr><td>31:</td><td>9.1</td><td>↓</td></tr> <tr><td>32:</td><td>8.5</td><td>↓</td></tr> <tr><td>33:</td><td>9.5</td><td>↗</td></tr> <tr><td>34:</td><td>8.2</td><td>→</td></tr> <tr><td>35:</td><td>9.9</td><td>→</td></tr> <tr><td>36:</td><td>8.4</td><td>↗</td></tr> <tr><td>37:</td><td>10.1</td><td>←</td></tr> <tr><td>38:</td><td>8.9</td><td>←</td></tr> <tr><td>39:</td><td>8.0</td><td>←</td></tr> <tr><td>40:</td><td>8.8</td><td>←</td></tr> <tr><td colspan="2">Series</td><td>85.0</td></tr> <tr><td colspan="2">Total</td><td>337.0</td></tr> </table>	31:	9.1	↓	32:	8.5	↓	33:	9.5	↗	34:	8.2	→	35:	9.9	→	36:	8.4	↗	37:	10.1	←	38:	8.9	←	39:	8.0	←	40:	8.8	←	Series		85.0	Total		337.0
31:	9.1	↓																																			
32:	8.5	↓																																			
33:	9.5	↗																																			
34:	8.2	→																																			
35:	9.9	→																																			
36:	8.4	↗																																			
37:	10.1	←																																			
38:	8.9	←																																			
39:	8.0	←																																			
40:	8.8	←																																			
Series		85.0																																			
Total		337.0																																			

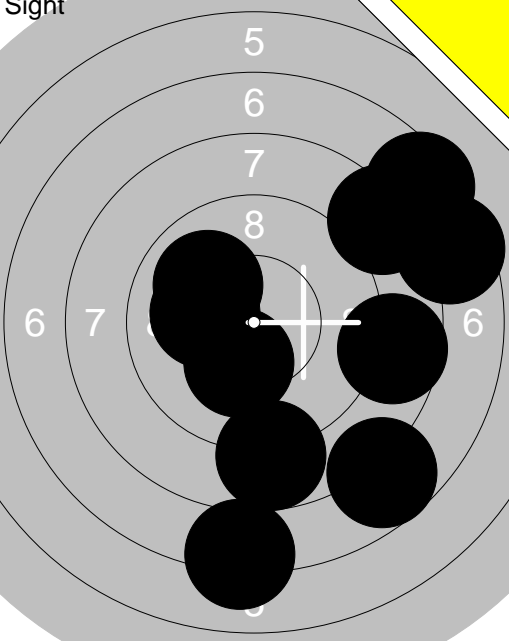
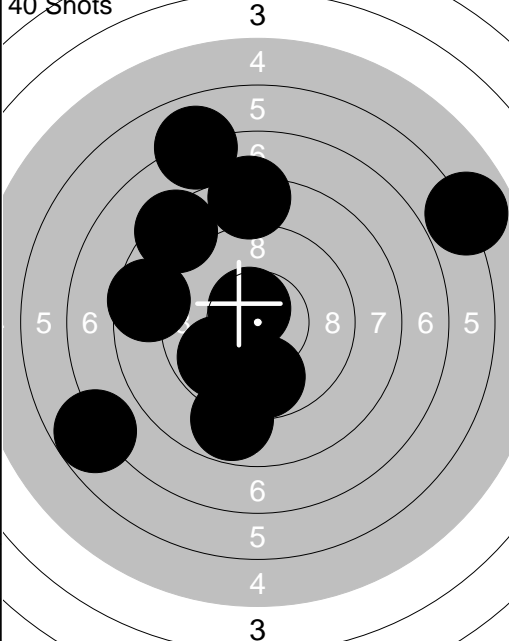
<p>Sight</p> 	<p>40 Shots</p> 	<table style="width:100%; border-collapse: collapse;"> <tr><td>1: 10.1</td><td style="text-align: right;">←</td><td>1: 9.8</td><td style="text-align: right;">↓</td></tr> <tr><td>2: *10.2</td><td style="text-align: right;">↓</td><td>2: 6.8</td><td style="text-align: right;">↙</td></tr> <tr><td>3: 10.0</td><td style="text-align: right;">↗</td><td>3: *10.6</td><td style="text-align: right;">↗</td></tr> <tr><td>4: 7.7</td><td style="text-align: right;">↓</td><td>4: 8.8</td><td style="text-align: right;">↓</td></tr> <tr><td>5: 7.4</td><td style="text-align: right;">↗</td><td>5: 8.3</td><td style="text-align: right;">↗</td></tr> <tr><td>6: 7.1</td><td style="text-align: right;">↓</td><td>6: 8.3</td><td style="text-align: right;">↑</td></tr> <tr><td>7: 8.6</td><td style="text-align: right;">→</td><td>7: 5.9</td><td style="text-align: right;">↗</td></tr> <tr><td>8: 7.5</td><td style="text-align: right;">↗</td><td>8: 8.6</td><td style="text-align: right;">←</td></tr> <tr><td>9: 8.3</td><td style="text-align: right;">↗</td><td>9: 9.8</td><td style="text-align: right;">↙</td></tr> <tr><td>10: 8.7</td><td style="text-align: right;">↓</td><td>10: 7.0</td><td style="text-align: right;">↑</td></tr> <tr><td colspan="2">Series 82.0</td><td colspan="2">Series 78.0</td></tr> <tr><td colspan="2">Total 0.0</td><td colspan="2">Total 78.0</td></tr> </table>	1: 10.1	←	1: 9.8	↓	2: *10.2	↓	2: 6.8	↙	3: 10.0	↗	3: *10.6	↗	4: 7.7	↓	4: 8.8	↓	5: 7.4	↗	5: 8.3	↗	6: 7.1	↓	6: 8.3	↑	7: 8.6	→	7: 5.9	↗	8: 7.5	↗	8: 8.6	←	9: 8.3	↗	9: 9.8	↙	10: 8.7	↓	10: 7.0	↑	Series 82.0		Series 78.0		Total 0.0		Total 78.0	
1: 10.1	←	1: 9.8	↓																																															
2: *10.2	↓	2: 6.8	↙																																															
3: 10.0	↗	3: *10.6	↗																																															
4: 7.7	↓	4: 8.8	↓																																															
5: 7.4	↗	5: 8.3	↗																																															
6: 7.1	↓	6: 8.3	↑																																															
7: 8.6	→	7: 5.9	↗																																															
8: 7.5	↗	8: 8.6	←																																															
9: 8.3	↗	9: 9.8	↙																																															
10: 8.7	↓	10: 7.0	↑																																															
Series 82.0		Series 78.0																																																
Total 0.0		Total 78.0																																																

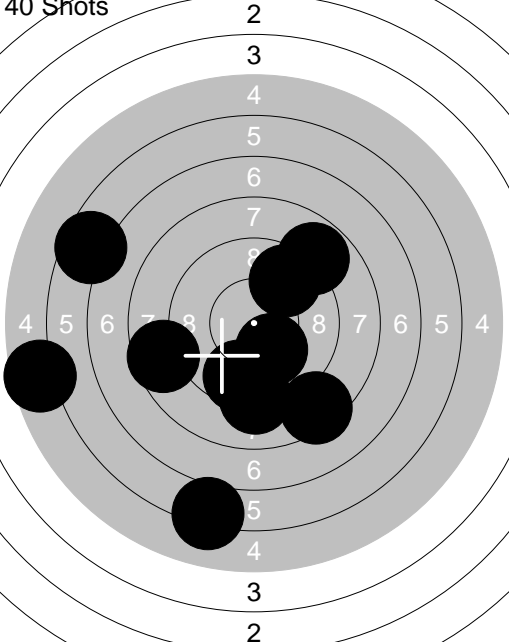
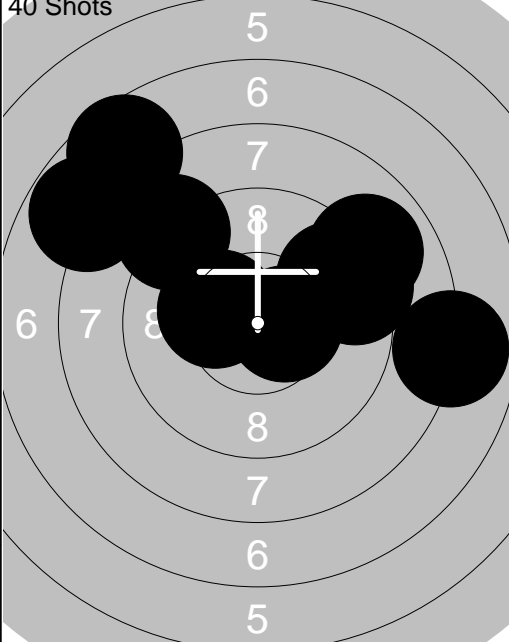
<p>40 Shots</p> 	<p>40 Shots</p> 	<table style="width:100%; border-collapse: collapse;"> <tr><td>11: 9.1</td><td style="text-align: right;">↓</td><td>21: *10.3</td><td style="text-align: right;">↙</td></tr> <tr><td>12: 6.1</td><td style="text-align: right;">↓</td><td>22: *10.3</td><td style="text-align: right;">↙</td></tr> <tr><td>13: 8.6</td><td style="text-align: right;">←</td><td>23: *10.5</td><td style="text-align: right;">→</td></tr> <tr><td>14: 5.5</td><td style="text-align: right;">←</td><td>24: 9.3</td><td style="text-align: right;">↗</td></tr> <tr><td>15: *10.2</td><td style="text-align: right;">↓</td><td>25: 8.9</td><td style="text-align: right;">↗</td></tr> <tr><td>16: 8.4</td><td style="text-align: right;">↓</td><td>26: 9.6</td><td style="text-align: right;">↗</td></tr> <tr><td>17: 6.5</td><td style="text-align: right;">↙</td><td>27: 7.9</td><td style="text-align: right;">→</td></tr> <tr><td>18: 9.7</td><td style="text-align: right;">↗</td><td>28: 7.8</td><td style="text-align: right;">↙</td></tr> <tr><td>19: 9.6</td><td style="text-align: right;">↓</td><td>29: 7.6</td><td style="text-align: right;">↗</td></tr> <tr><td>20: 8.8</td><td style="text-align: right;">↗</td><td>30: 9.0</td><td style="text-align: right;">↙</td></tr> <tr><td colspan="2">Series 78.0</td><td colspan="2">Series 86.0</td></tr> <tr><td colspan="2">Total 156.0</td><td colspan="2">Total 242.0</td></tr> </table>	11: 9.1	↓	21: *10.3	↙	12: 6.1	↓	22: *10.3	↙	13: 8.6	←	23: *10.5	→	14: 5.5	←	24: 9.3	↗	15: *10.2	↓	25: 8.9	↗	16: 8.4	↓	26: 9.6	↗	17: 6.5	↙	27: 7.9	→	18: 9.7	↗	28: 7.8	↙	19: 9.6	↓	29: 7.6	↗	20: 8.8	↗	30: 9.0	↙	Series 78.0		Series 86.0		Total 156.0		Total 242.0	
11: 9.1	↓	21: *10.3	↙																																															
12: 6.1	↓	22: *10.3	↙																																															
13: 8.6	←	23: *10.5	→																																															
14: 5.5	←	24: 9.3	↗																																															
15: *10.2	↓	25: 8.9	↗																																															
16: 8.4	↓	26: 9.6	↗																																															
17: 6.5	↙	27: 7.9	→																																															
18: 9.7	↗	28: 7.8	↙																																															
19: 9.6	↓	29: 7.6	↗																																															
20: 8.8	↗	30: 9.0	↙																																															
Series 78.0		Series 86.0																																																
Total 156.0		Total 242.0																																																

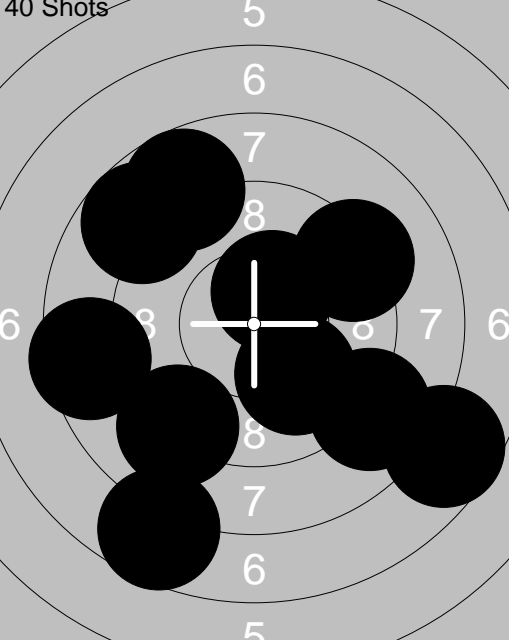
<p>40 Shots</p> 	<table style="width:100%; border-collapse: collapse;"> <tr><td>31: 9.1</td><td style="text-align: right;">↙</td></tr> <tr><td>32: 8.5</td><td style="text-align: right;">←</td></tr> <tr><td>33: 9.2</td><td style="text-align: right;">↗</td></tr> <tr><td>34: 8.7</td><td style="text-align: right;">↗</td></tr> <tr><td>35: 8.8</td><td style="text-align: right;">↓</td></tr> <tr><td>36: 10.0</td><td style="text-align: right;">↓</td></tr> <tr><td>37: 7.6</td><td style="text-align: right;">↓</td></tr> <tr><td>38: 8.7</td><td style="text-align: right;">↗</td></tr> <tr><td>39: 7.6</td><td style="text-align: right;">↓</td></tr> <tr><td>40: *10.4</td><td style="text-align: right;">↗</td></tr> <tr><td colspan="2">Series 84.0</td></tr> <tr><td colspan="2">Total 326.0</td></tr> </table>	31: 9.1	↙	32: 8.5	←	33: 9.2	↗	34: 8.7	↗	35: 8.8	↓	36: 10.0	↓	37: 7.6	↓	38: 8.7	↗	39: 7.6	↓	40: *10.4	↗	Series 84.0		Total 326.0		
31: 9.1	↙																									
32: 8.5	←																									
33: 9.2	↗																									
34: 8.7	↗																									
35: 8.8	↓																									
36: 10.0	↓																									
37: 7.6	↓																									
38: 8.7	↗																									
39: 7.6	↓																									
40: *10.4	↗																									
Series 84.0																										
Total 326.0																										

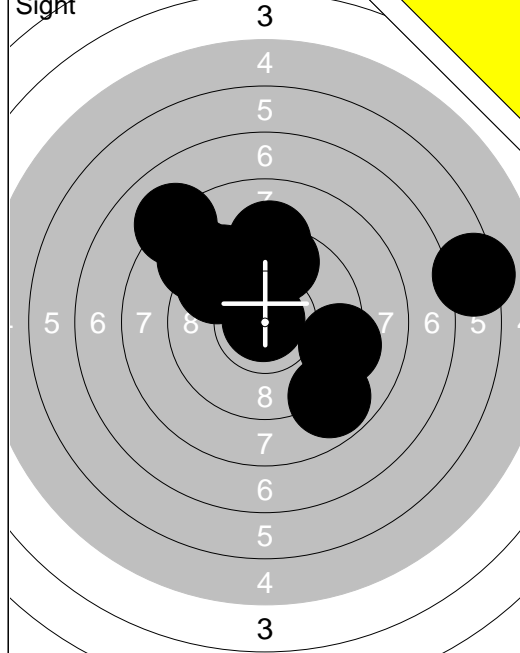

1:	8.8	↘
2:	9.6	↗
3:	9.3	→
4:	9.6	↑
5:	8.1	↗
6:	*10.9	↗
7:	6.3	→
8:	9.2	↑
9:	9.4	↗
10:	9.0	↖
Series		86.0
Total		0.0

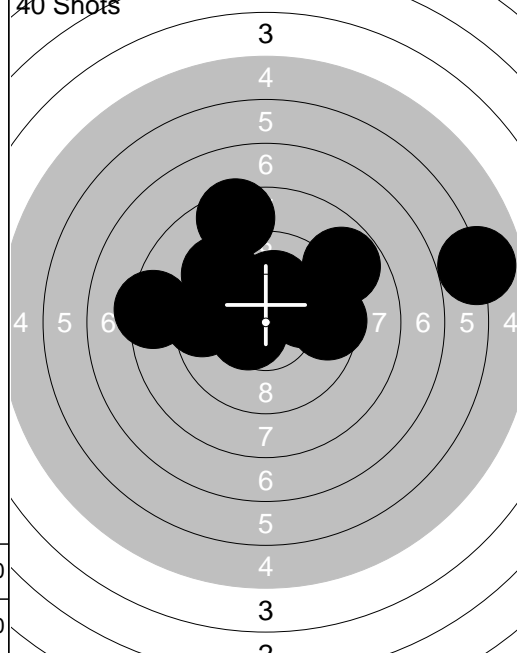

1:	5.9	→
2:	8.5	↑
3:	*10.2	↑
4:	*10.5	↙
5:	9.4	↖
6:	8.8	↗
7:	9.5	→
8:	10.0	→
9:	8.4	←
10:	9.5	←
Series		86.0
Total		86.0

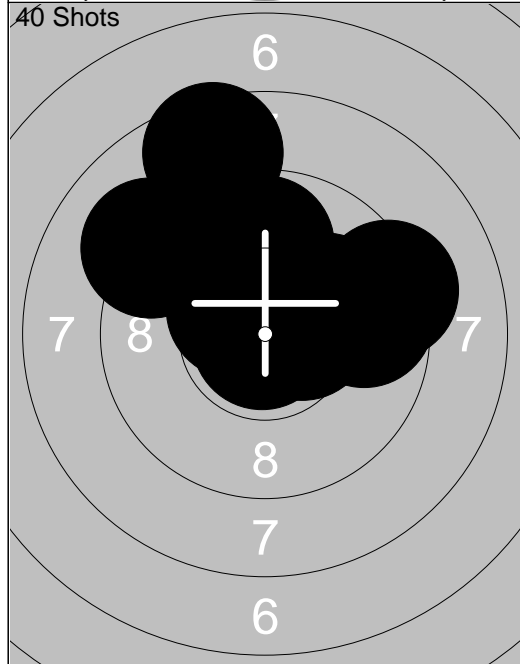

11:	9.1	↖
12:	9.7	→
13:	9.8	↑
14:	*10.9	↘
15:	10.1	↗
16:	*10.3	↑
17:	*10.5	↖
18:	9.3	→
19:	8.5	↑
20:	*10.5	→
Series		94.0
Total		180.0

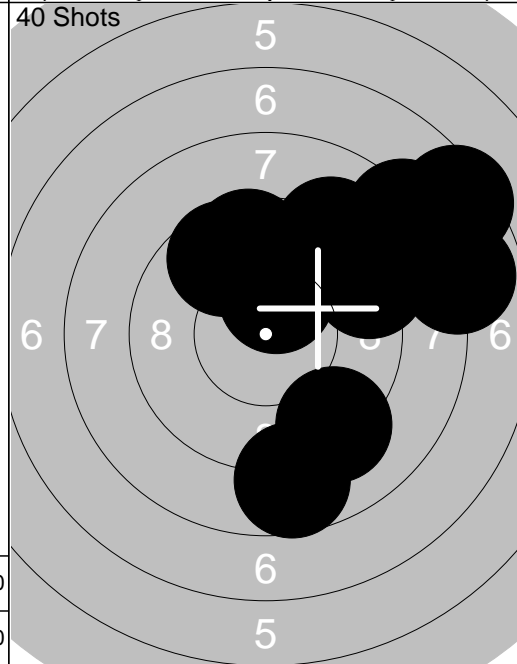

21:	9.6	↖
22:	9.2	↗
23:	7.9	→
24:	*10.3	↑
25:	7.4	↗
26:	8.2	↗
27:	9.1	↗
28:	9.6	↑
29:	8.7	↘
30:	9.2	↘
Series		85.0
Total		265.0

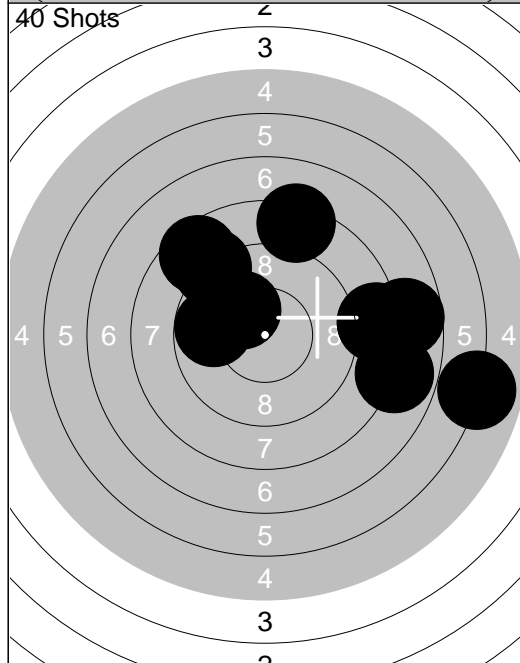

31:	8.4	→
32:	8.5	↗
33:	9.0	↗
34:	7.7	→
35:	8.4	→
36:	7.8	→
37:	5.9	→
38:	8.3	↑
39:	9.7	←
40:	*10.2	↖
Series		79.0
Total		344.0

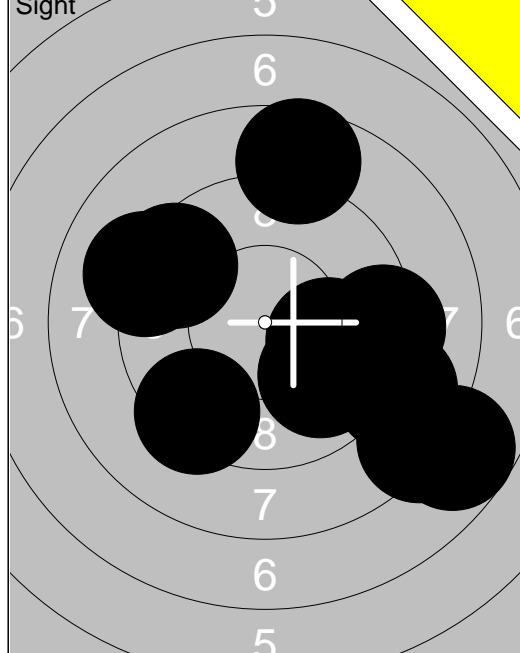

1:	7.7	↘
2:	9.1	↗
3:	9.4	↙
4:	9.3	→
5:	8.2	↙
6:	10.0	→
7:	9.9	↙
8:	8.6	↗
9:	9.4	↗
10:	8.9	↘
Series		86.0
Total		0.0

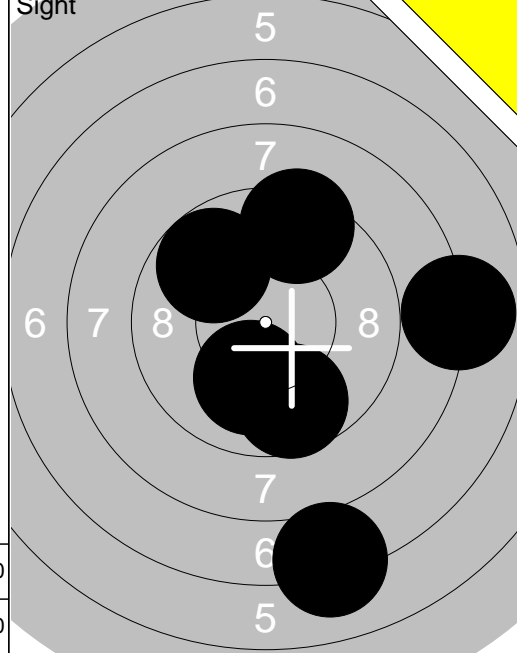

11:	7.1	↘
12:	9.4	↗
13:	9.7	↙
14:	7.9	→
15:	10.1	↙
16:	9.8	↗
Series		51.0
Total		0.0

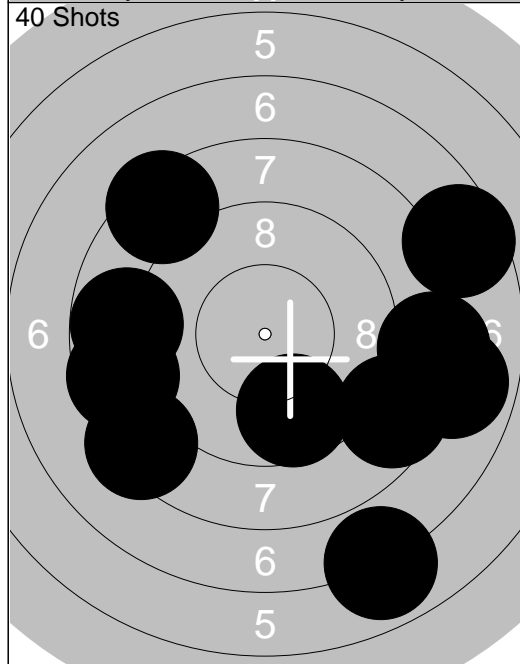

1:	6.9	↘
2:	8.4	↗
3:	9.7	↙
4:	8.6	↙
5:	8.3	→
6:	7.9	→
7:	8.6	←
8:	8.7	←
9:	7.5	↗
10:	8.3	↙
Series		77.0
Total		77.0

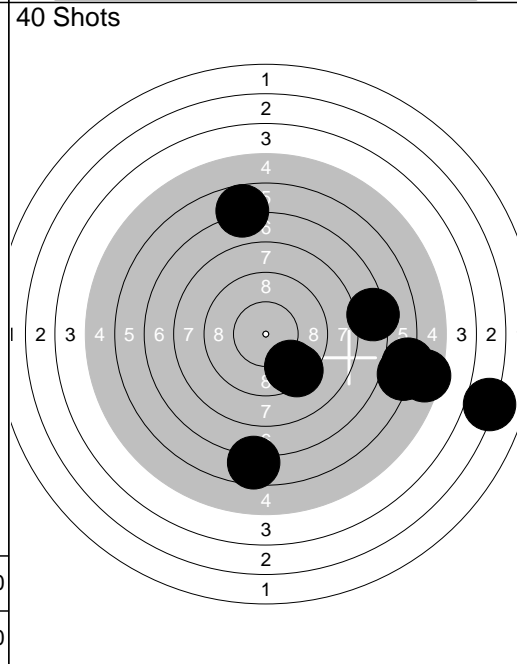

11:	9.3	↘
12:	5.4	→
13:	6.6	↙
14:	9.6	↙
15:	6.7	↗
16:	7.3	→
17:	6.1	→
18:	3.0	→
19:	6.1	→
20:	6.1	→
Series		63.0
Total		140.0

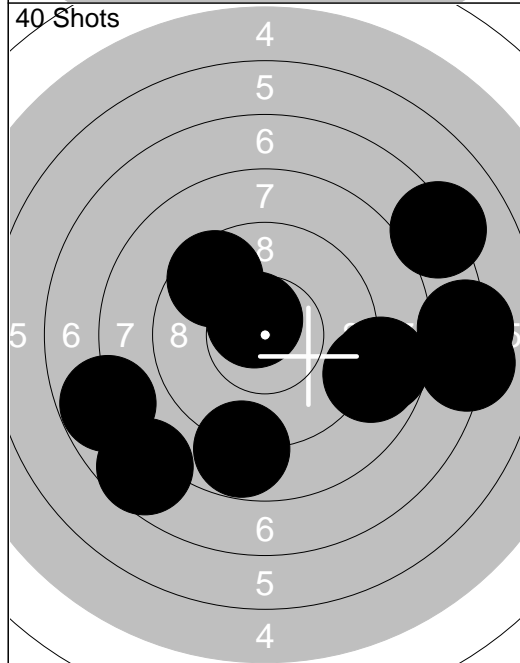

21:	7.2	→
22:	*10.6	↗
23:	7.8	←
24:	7.2	→
25:	9.6	↗
26:	8.7	→
27:	8.8	↙
28:	7.6	↙
29:	7.2	↗
30:	8.8	→
Series		78.0
Total		218.0

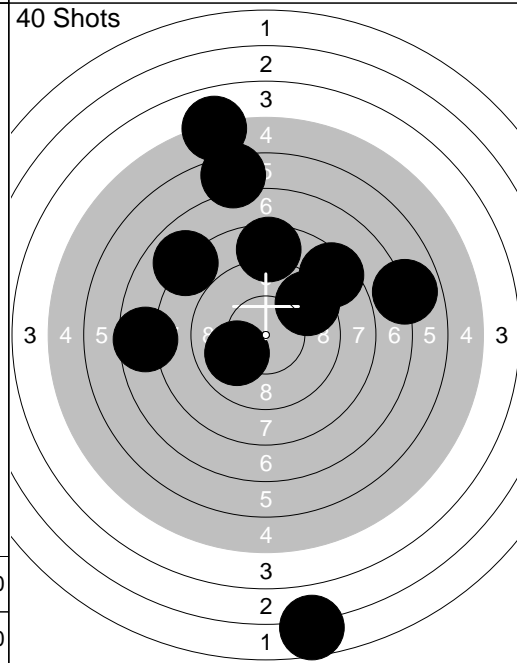

31:	5.0	↗
32:	8.5	↗
33:	7.6	←
34:	9.5	↗
35:	8.6	↗
36:	2.7	↙
37:	7.9	↗
38:	10.0	↙
39:	6.4	↗
40:	6.9	→
Series		68.0
Total		286.0

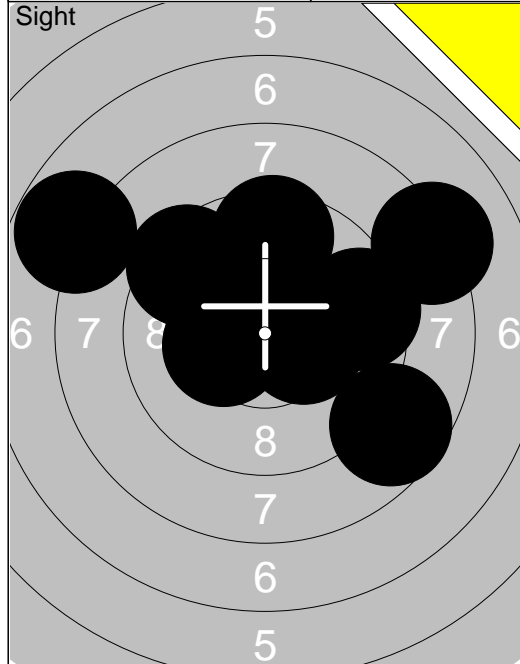

1:	8.7	↘
2:	9.5	→
3:	*10.3	←
4:	8.2	↗
5:	9.5	↑
6:	9.4	↗
7:	10.1	↑
8:	*10.4	→
9:	7.8	↖
10:	10.0	↗
Series		90.0
Total		0.0

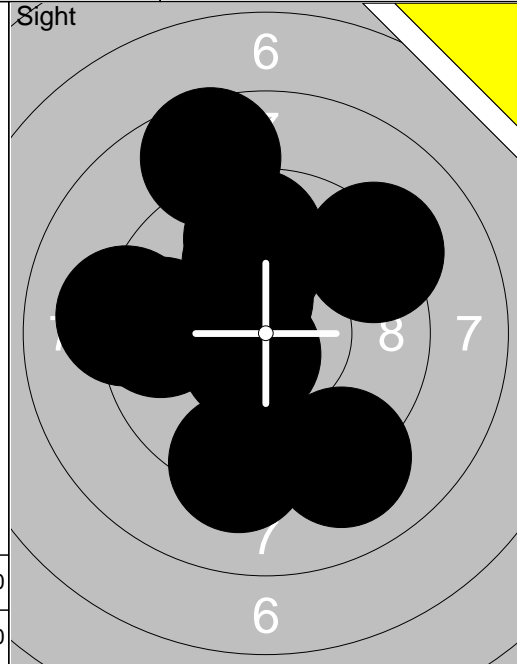

11:	*10.4	↗
12:	9.6	←
13:	9.1	↘
14:	9.7	↑
15:	8.6	↑
16:	9.2	↗
17:	9.2	←
18:	*10.6	↘
19:	9.3	↘
20:	10.0	↑
Series		92.0
Total		0.0

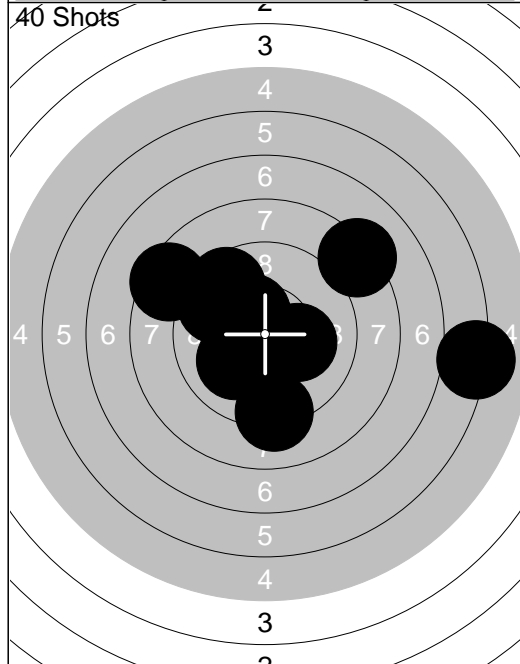

1:	8.4	↗
2:	9.2	↘
3:	9.6	↗
4:	*10.2	→
5:	*10.7	↗
6:	*10.4	↗
7:	8.2	↗
8:	6.1	→
9:	10.0	↘
10:	9.7	↖
Series		89.0
Total		89.0

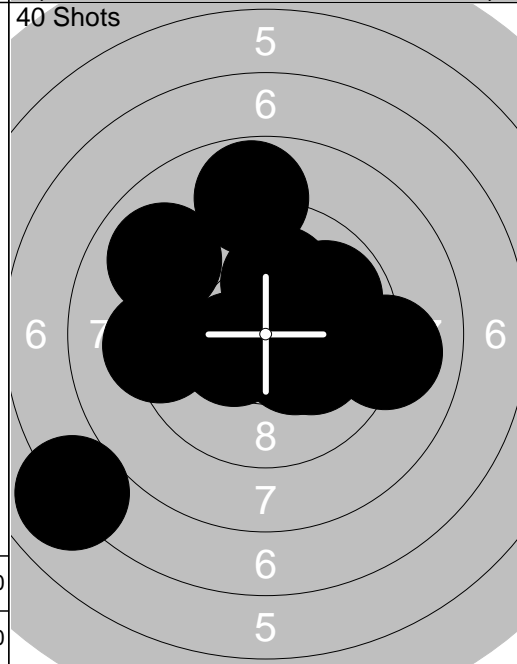

11:	10.1	↑
12:	*10.4	↘
13:	9.3	←
14:	7.0	↖
15:	9.1	→
16:	*10.4	←
17:	*10.2	→
18:	9.0	↖
19:	8.8	↑
20:	9.9	↗
Series		91.0
Total		180.0

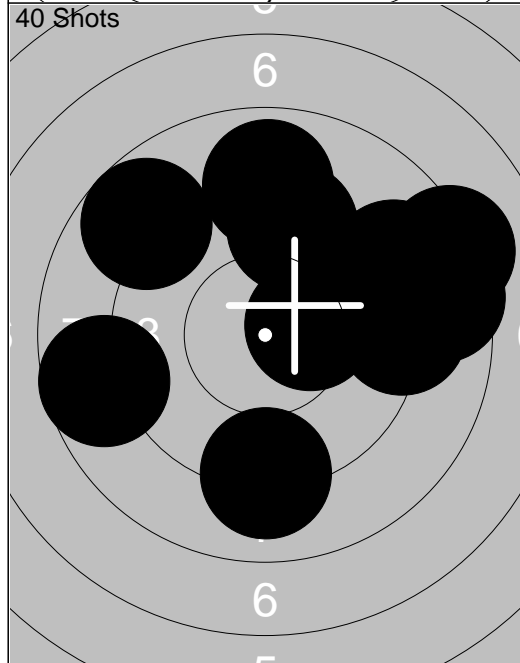

21:	8.2	→
22:	9.0	↗
23:	9.1	→
24:	8.7	↖
25:	8.9	↑
26:	8.7	←
27:	9.4	↑
28:	8.5	→
29:	9.1	↘
30:	*10.3	→
Series		86.0
Total		266.0

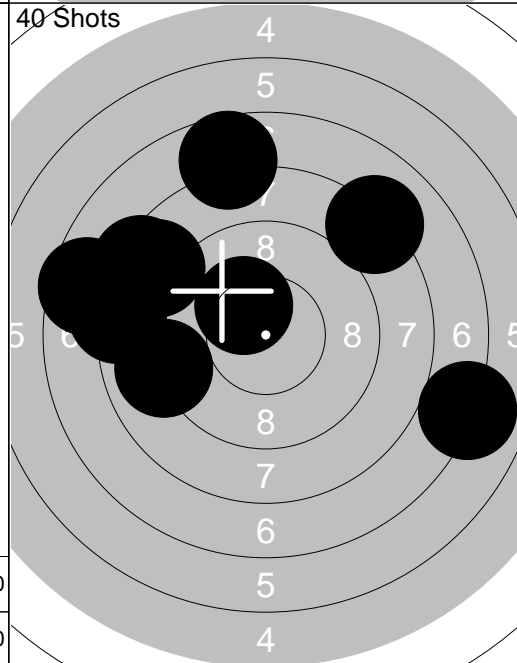

31:	*10.3	↖
32:	9.0	←
33:	7.7	↑
34:	7.8	←
35:	8.2	←
36:	7.6	←
37:	8.1	↗
38:	7.0	→
39:	8.6	↗
40:	8.3	↖
Series		79.0
Total		345.0

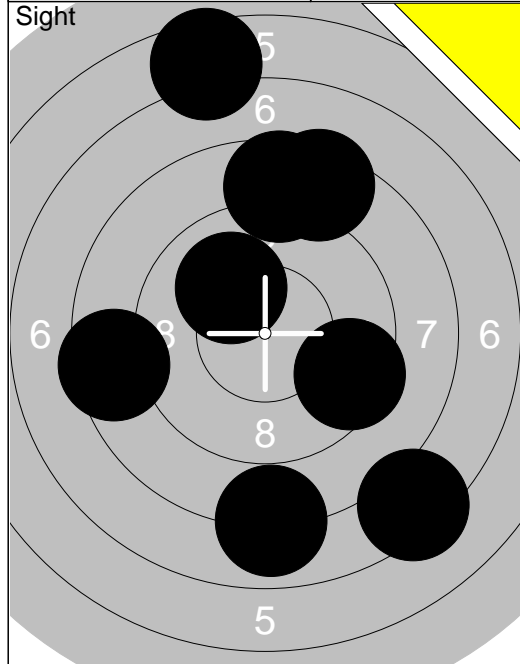

1:	8.6	↑
2:	7.3	↘
3:	8.4	↑
4:	10.0	↗
5:	6.5	↑
6:	8.5	←
7:	9.4	↘
8:	7.9	↓
Series		63.0
Total		0.0

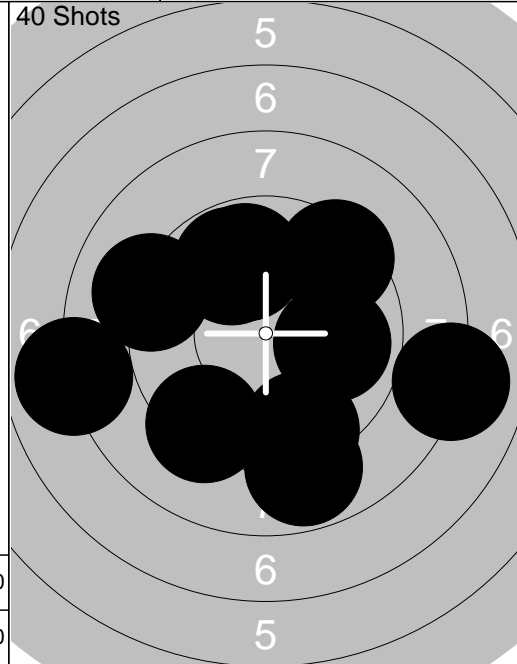

1:	8.8	↓
2:	9.4	↗
3:	9.3	↘
4:	9.1	↖
5:	9.4	↓
6:	9.8	↑
7:	7.9	←
8:	9.9	→
9:	8.0	↘
10:	9.8	↑
Series		86.0
Total		86.0

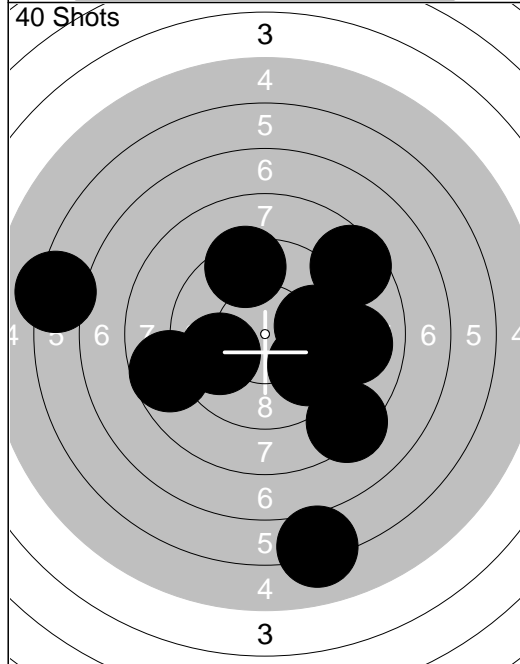

11:	9.4	↑
12:	9.9	←
13:	6.1	↓
14:	9.8	→
15:	9.0	→
16:	8.3	↘
17:	9.8	↘
18:	8.7	←
19:	6.2	←
20:	8.5	↗
Series		81.0
Total		167.0

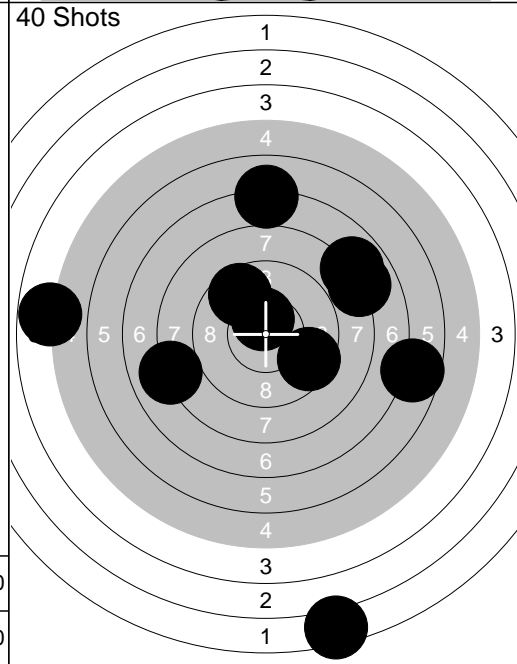

21:	9.6	↖
22:	7.0	↑
23:	4.8	←
24:	6.6	→
25:	2.3	↓
26:	7.9	↗
27:	7.9	↗
28:	9.5	↘
29:	8.0	←
30:	*10.5	↑
Series		69.0
Total		236.0

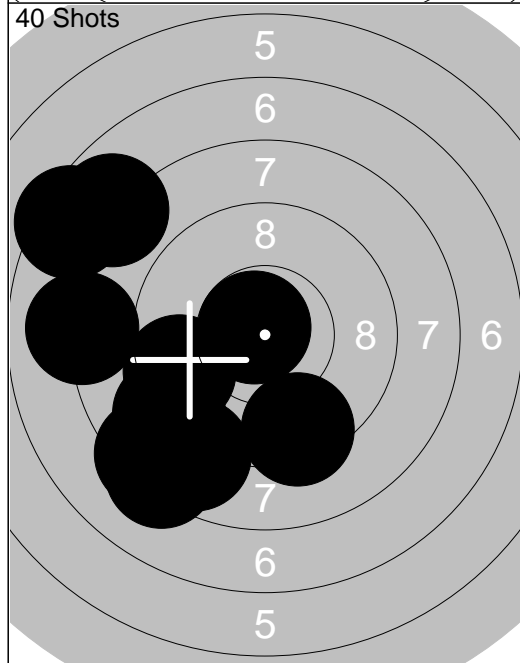

31:	9.5	←
32:	8.7	↘
33:	9.0	↘
34:	8.3	↘
35:	8.2	↘
36:	7.4	↗
37:	*10.7	↖
38:	7.8	↗
39:	8.0	←
40:	9.4	↓
Series		83.0
Total		319.0

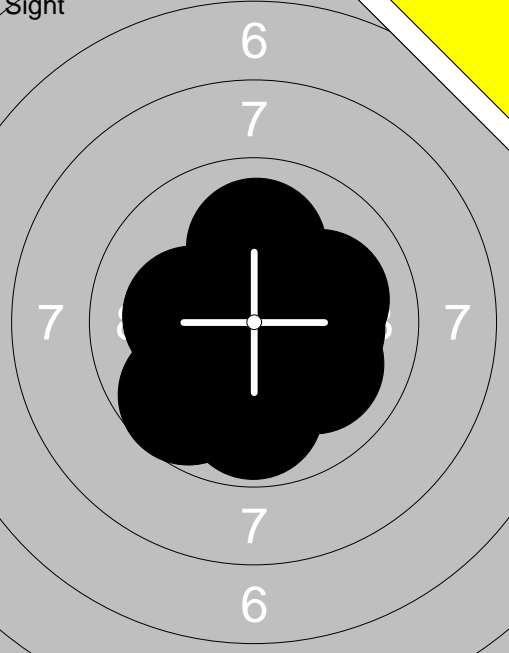
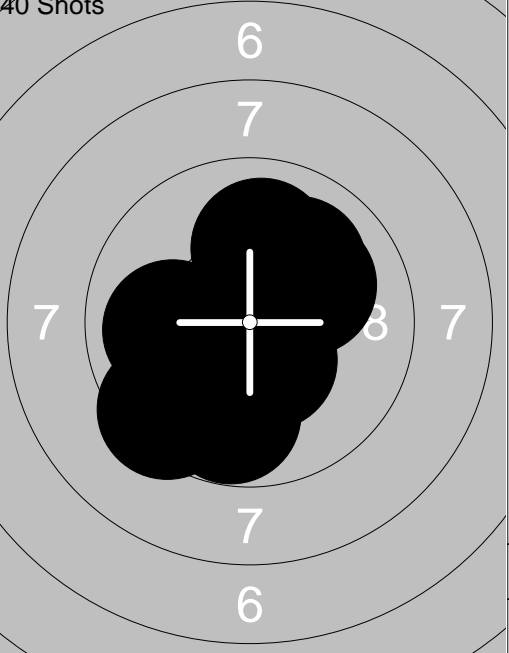
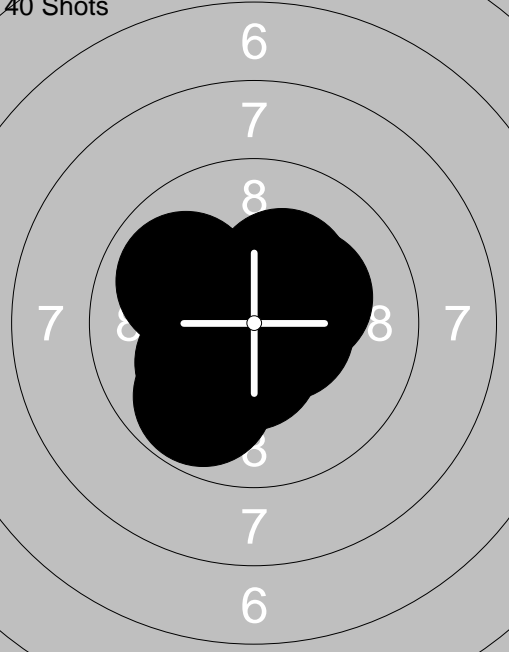
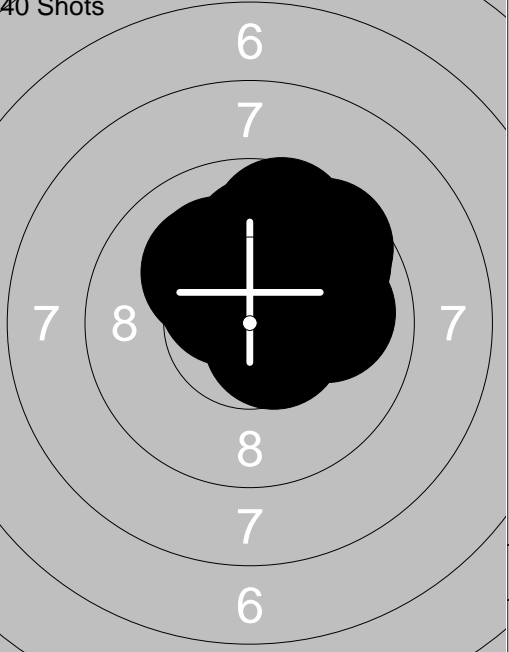
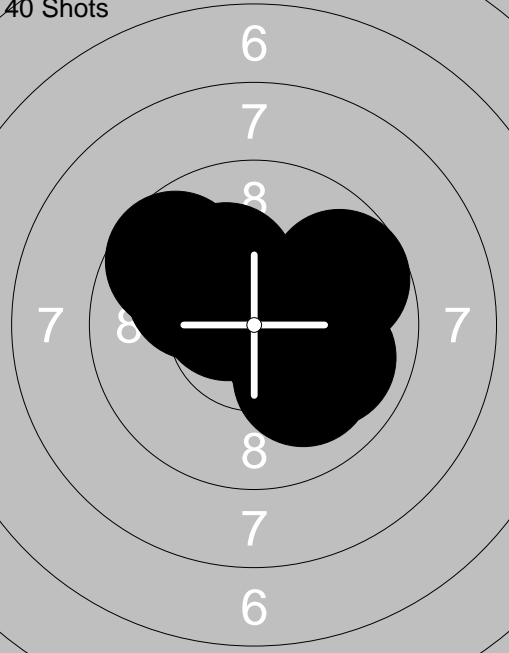
<p>Sight</p> 	<p>1: *10.6 ↓</p> <p>2: 9.7 ↙</p> <p>3: 9.8 ↓</p> <p>4: *10.3 ↓</p> <p>5: 10.0 ↑</p> <p>6: 10.0 ↘</p> <p>7: *10.8 ↑</p> <p>8: *10.2 ←</p> <p>9: *10.2 →</p> <p>10: 10.1 ↘</p>	<p>40 Shots</p> 	<p>1: 9.8 ↓</p> <p>2: 10.0 ↗</p> <p>3: 10.0 ↑</p> <p>4: 9.8 ↙</p> <p>5: *10.3 ↗</p> <p>6: *10.4 ↓</p> <p>7: 10.0 ←</p> <p>8: *10.5 ↓</p> <p>9: 9.4 ↙</p> <p>10: 10.1 ↗</p>
	<p>Series 98.0</p> <p>Total 0.0</p>		<p>Series 97.0</p> <p>Total 97.0</p>
<p>40 Shots</p> 	<p>11: 10.1 ↙</p> <p>12: *10.5 ↓</p> <p>13: 9.8 ↙</p> <p>14: 9.9 ↙</p> <p>15: 10.1 ↙</p> <p>16: *10.3 ↗</p> <p>17: *10.3 ↗</p> <p>18: *10.5 ↙</p> <p>19: *10.6 →</p> <p>20: *10.8 ↑</p>	<p>40 Shots</p> 	<p>21: *10.6 ↘</p> <p>22: 9.7 ↑</p> <p>23: 10.1 ↖</p> <p>24: 10.1 ↖</p> <p>25: 9.6 ↗</p> <p>26: 10.0 →</p> <p>27: 10.0 →</p> <p>28: 9.8 ↗</p> <p>29: 10.0 ↑</p> <p>30: *10.5 ↖</p>
	<p>Series 98.0</p> <p>Total 195.0</p>		<p>Series 97.0</p> <p>Total 292.0</p>
<p>40 Shots</p> 	<p>31: 9.7 ↖</p> <p>32: *10.6 ↑</p> <p>33: 9.7 ↗</p> <p>34: *10.6 ↖</p> <p>35: *10.3 ↘</p> <p>36: *10.2 ↑</p> <p>37: 10.0 ↘</p> <p>38: *10.5 ↗</p> <p>39: 9.9 ↘</p> <p>40: 10.1 ↖</p>		
	<p>Series 97.0</p> <p>Total 389.0</p>		

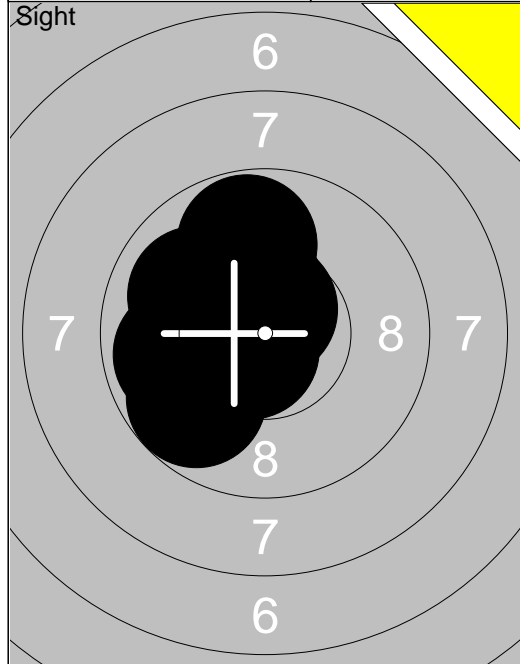

1:	*10.7	↙
2:	*10.6	↑
3:	9.8	↑
4:	*10.4	↑
5:	*10.4	↗
6:	10.1	↗
7:	9.7	↘
8:	10.0	↘
9:	9.9	←
10:	*10.6	↙
Series		97.0
Total		0.0

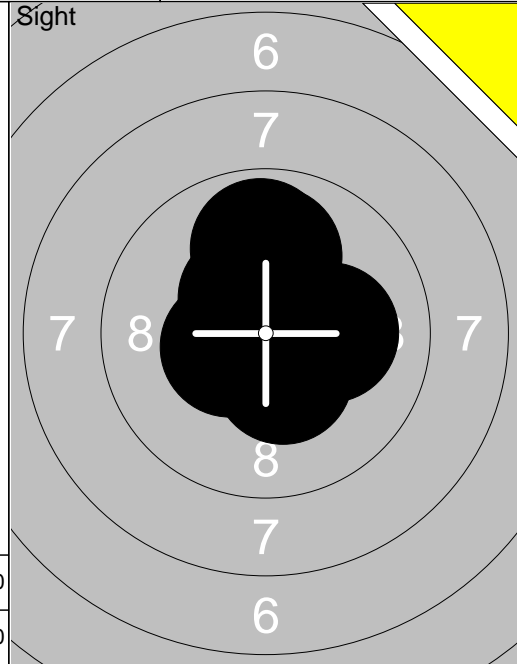

11:	*10.5	↗
12:	*10.4	↘
13:	10.1	→
14:	10.0	↑
15:	*10.5	←
16:	*10.8	↙
17:	9.9	↑
18:	*10.7	↘
19:	*10.4	↑
Series		89.0
Total		0.0

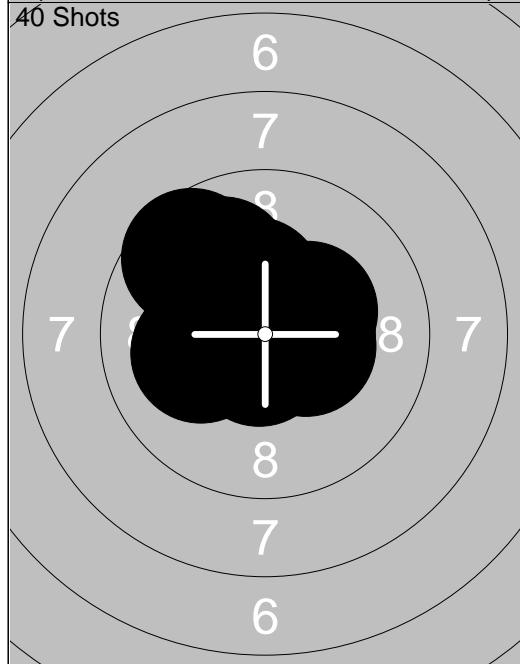

1:	*10.4	→
2:	*10.3	↗
3:	*10.4	→
4:	10.1	←
5:	9.6	↗
6:	*10.3	↑
7:	*10.4	↗
8:	9.9	↗
9:	*10.7	←
10:	*10.7	↘
Series		98.0
Total		98.0

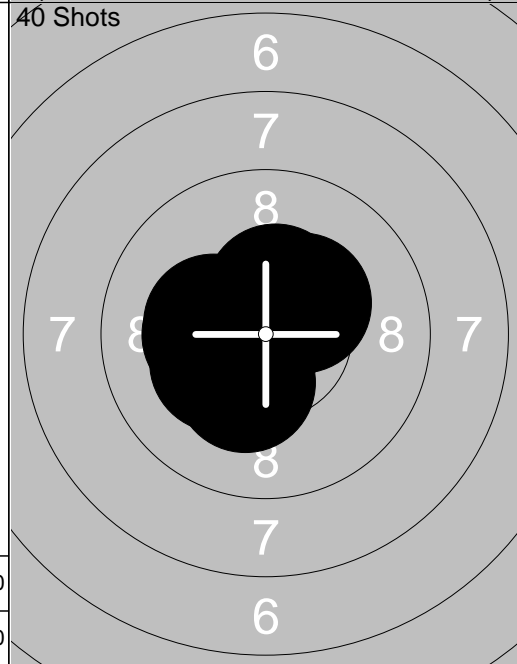

11:	*10.3	↙
12:	*10.3	←
13:	*10.3	←
14:	*10.7	↗
15:	*10.5	↙
16:	*10.3	↘
17:	*10.3	↗
18:	*10.5	↗
19:	*10.6	↑
20:	*10.4	↑
Series		100.0
Total		198.0

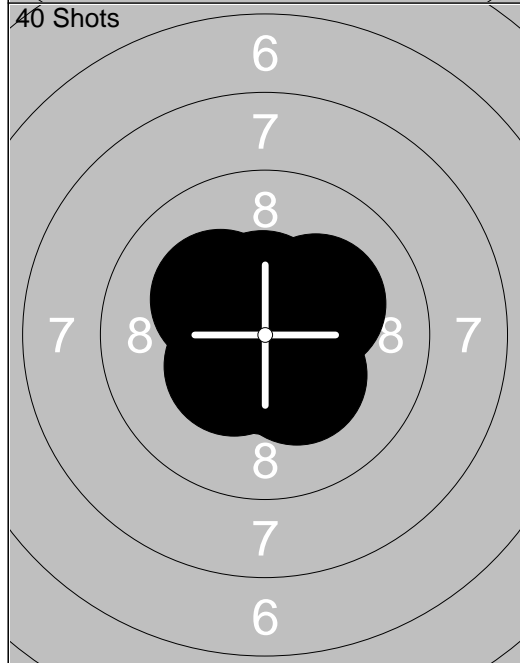

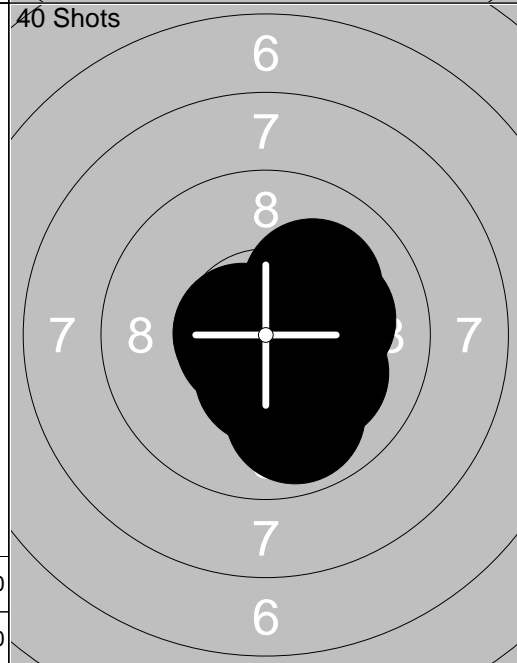

21:	*10.3	↘
22:	*10.2	↗
23:	*10.5	↑
24:	*10.4	↙
25:	*10.2	↙
26:	*10.8	←
27:	*10.7	↘
28:	*10.6	↘
29:	*10.5	↘
30:	*10.6	↘
Series		100.0
Total		298.0

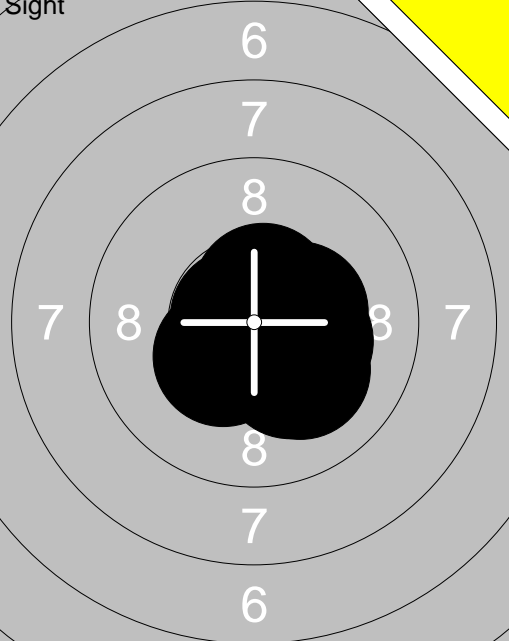
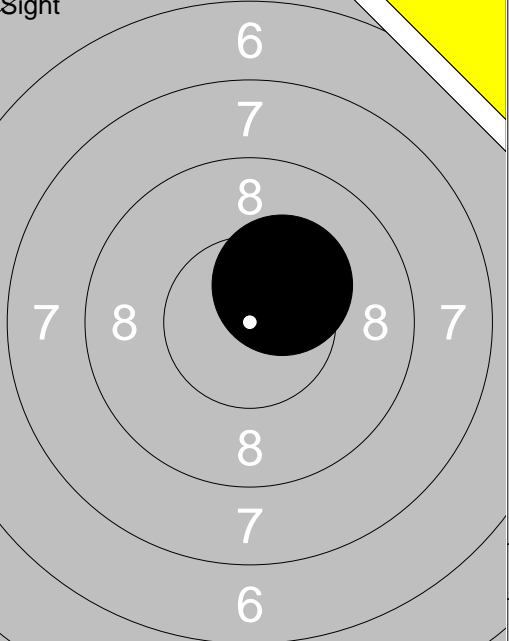

31:	*10.4	↘
32:	*10.2	→
33:	*10.7	←
34:	10.1	↘
35:	*10.6	↘
36:	*10.6	↘
37:	*10.4	↗
38:	9.9	↘
39:	*10.7	←
40:	10.1	↗
Series		99.0
Total		397.0

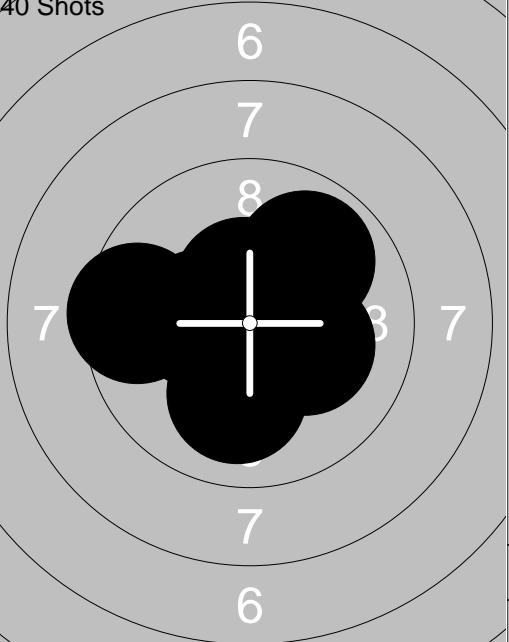
<p>Sight</p> 	<p>1: *10.4 ↙</p> <p>2: *10.8 ↖</p> <p>3: *10.2 ↘</p> <p>4: *10.2 ↘</p> <p>5: *10.4 →</p> <p>6: *10.7 ↓</p> <p>7: *10.3 →</p> <p>8: *10.6 ↗</p> <p>9: 10.1 ↘</p> <p>10: *10.3 ↘</p>	<p>Sight</p> 	<p>11: *10.3 ↗</p>
Series 100.0		Series 10.0	
Total 0.0		Total 0.0	

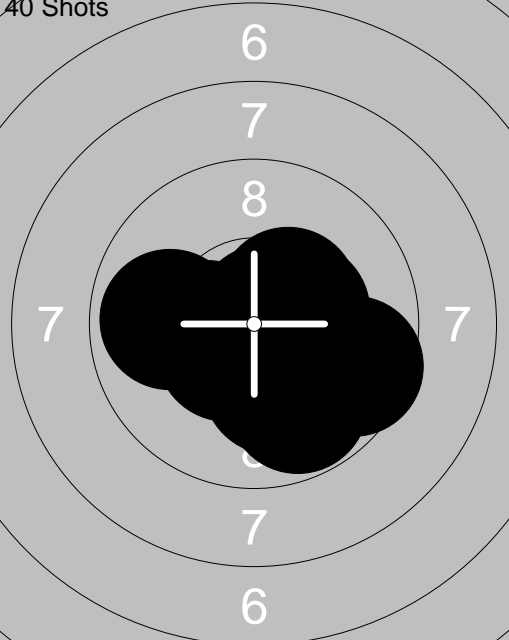
<p>40 Shots</p> 	<p>1: *10.2 ↓</p> <p>2: *10.2 →</p> <p>3: *10.5 ↗</p> <p>4: *10.8 ↗</p> <p>5: *10.2 ↘</p> <p>6: 10.1 →</p> <p>7: *10.4 ↓</p> <p>8: *10.5 ↗</p> <p>9: *10.2 ↖</p> <p>10: 10.0 ↖</p>	<p>40 Shots</p> 	<p>11: *10.2 →</p> <p>12: 9.9 ↗</p> <p>13: *10.3 ↖</p> <p>14: 10.0 ↓</p> <p>15: 9.5 ↖</p> <p>16: *10.4 →</p> <p>17: *10.6 ↗</p> <p>18: *10.8 ↗</p> <p>19: *10.5 ↗</p> <p>20: *10.3 ↗</p>
Series 100.0		Series 98.0	
Total 100.0		Total 198.0	

<p>40 Shots</p> 	<p>21: *10.5 ↘</p> <p>22: 9.9 ↖</p> <p>23: 9.8 ↘</p> <p>24: *10.4 →</p> <p>25: 9.6 →</p> <p>26: *10.4 ↗</p> <p>27: *10.4 →</p> <p>28: *10.4 ↖</p> <p>29: 10.1 ↘</p> <p>30: *10.8 ↗</p>	<p>40 Shots</p> 	<p>31: 10.0 ↓</p> <p>32: *10.3 ↗</p> <p>33: *10.5 →</p> <p>34: *10.6 ↗</p> <p>35: *10.6 ↖</p> <p>36: *10.6 →</p> <p>37: *10.8 ↗</p> <p>38: *10.4 ↖</p> <p>39: *10.7 ↓</p> <p>40: *10.7 ↖</p>
Series 97.0		Series 100.0	
Total 295.0		Total 395.0	

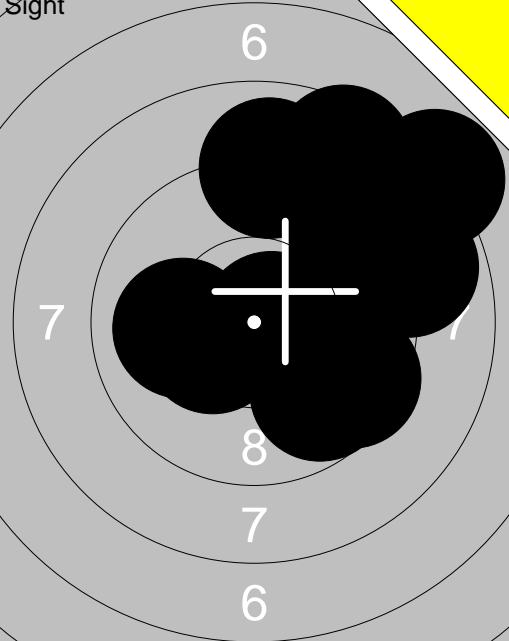
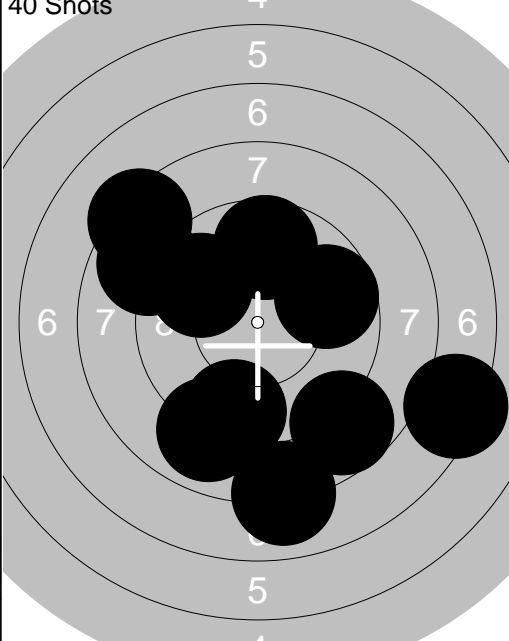
<p>Sight</p> 	<p>40 Shots</p> 	<p>1: 8.5 ↗</p> <p>2: 8.9 →</p> <p>3: 8.0 ↗</p> <p>4: 9.0 ↑</p> <p>5: 9.7 ↘</p> <p>6: *10.3 ↙</p> <p>7: 9.4 ↗</p> <p>8: 9.5 ↘</p> <p>9: 10.0 ←</p> <p>10: *10.7 →</p> <hr/> <p>Series 90.0</p> <p>Total 0.0</p>	<p>1: 8.8 ↖</p> <p>2: 9.7 ↑</p> <p>3: 9.7 →</p> <p>4: 7.3 ↘</p> <p>5: 9.4 ↓</p> <p>6: 8.9 ↘</p> <p>7: 9.8 ↗</p> <p>8: 8.0 ↓</p> <p>9: 8.7 ↘</p> <p>10: 8.3 ↗</p> <hr/> <p>Series 83.0</p> <p>Total 83.0</p>
---	--	---	---

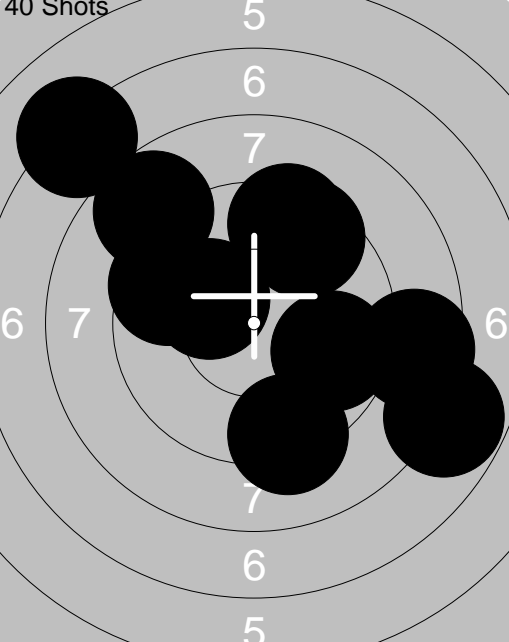
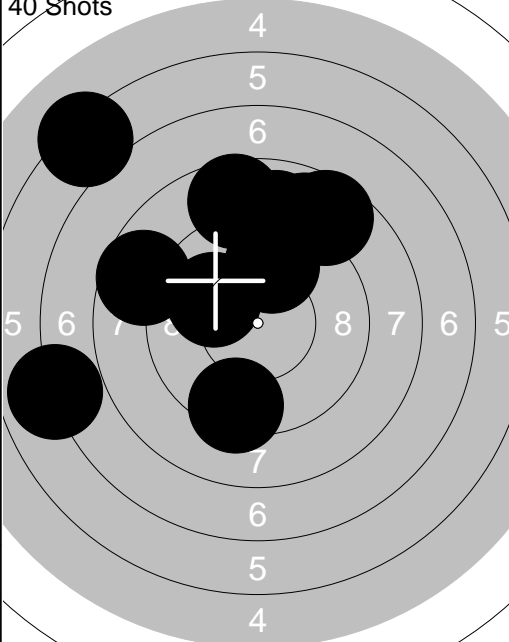
<p>40 Shots</p> 	<p>40 Shots</p> 	<p>11: 8.7 ↗</p> <p>12: 9.5 ↗</p> <p>13: 9.6 ↖</p> <p>14: 7.8 ↘</p> <p>15: *10.2 ↗</p> <p>16: 9.7 →</p> <p>17: 8.5 →</p> <p>18: 7.1 ↗</p> <p>19: 9.2 ↓</p> <p>20: 9.4 ↗</p> <hr/> <p>Series 85.0</p> <p>Total 168.0</p>	<p>21: 6.9 ↖</p> <p>22: 6.2 ↗</p> <p>23: 8.6 ↑</p> <p>24: 8.6 ↖</p> <p>25: 10.0 ↖</p> <p>26: 9.8 ↑</p> <p>27: 8.6 ↗</p> <p>28: 8.9 ↑</p> <p>29: 8.8 ↗</p> <p>30: 9.3 ↓</p> <hr/> <p>Series 80.0</p> <p>Total 248.0</p>
---	---	---	--

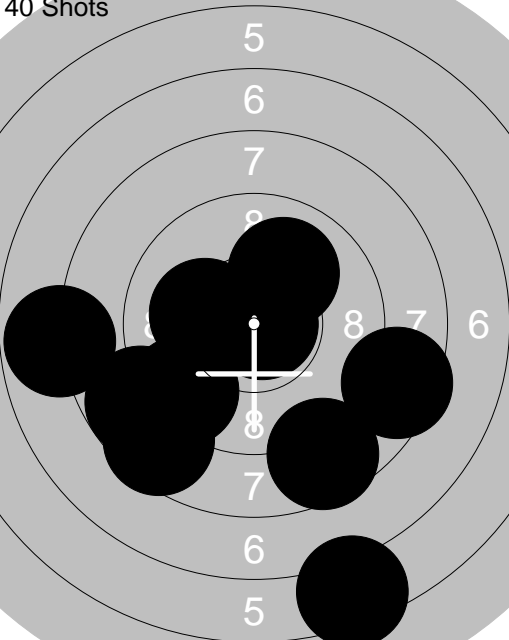
<p>40 Shots</p> 	<p>31: 10.0 ↗</p> <p>32: 8.5 →</p> <p>33: 9.4 ↖</p> <p>34: 6.4 ↓</p> <p>35: 8.7 ↖</p> <p>36: *10.8 →</p> <p>37: 8.6 ↖</p> <p>38: 10.1 ←</p> <p>39: 7.8 ←</p> <p>40: 8.6 ↘</p> <hr/> <p>Series 84.0</p> <p>Total 332.0</p>		
--	---	--	--

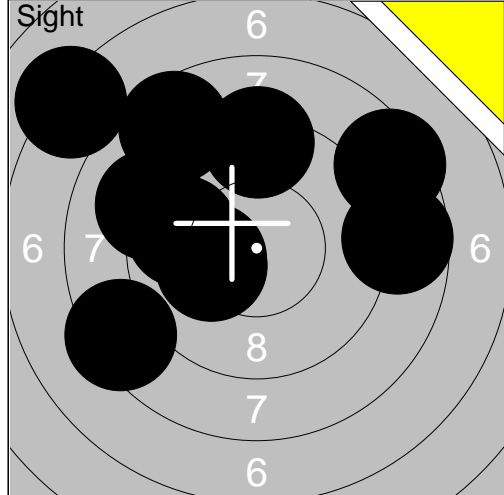

1:	8.4	↗
2:	9.3	↑
3:	7.2	↗
4:	8.6	↗
5:	*10.2	←
6:	*10.2	←
7:	9.7	←
8:	9.1	↖
9:	8.4	↙
10:	8.7	→
Series		86.0
Total		0.0



11:	8.9	↖
12:	10.0	←
13:	9.7	↑
14:	9.9	↗
15:	8.4	↗
16:	8.2	↖
17:	8.7	→
18:	8.6	↖
19:	10.1	↗
20:	9.0	↗
Series		87.0
Total		0.0

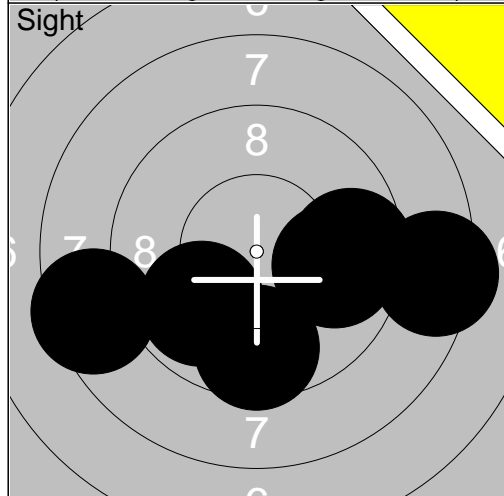

21:	8.4	→
22:	9.6	→
23:	9.8	→
24:	9.6	↓
25:	9.9	↙
26:	8.5	←
Series		52.0
Total		0.0

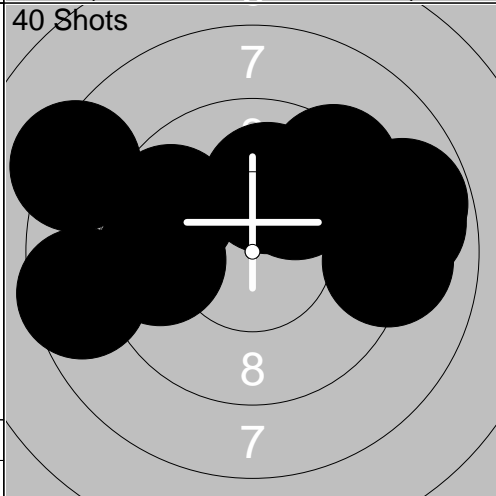

1:	8.8	→
2:	8.3	↖
3:	8.9	→
4:	10.0	↗
5:	9.7	↖
6:	10.1	↑
7:	9.1	→
8:	8.6	←
9:	9.7	←
10:	9.4	↗
Series		88.0
Total		88.0

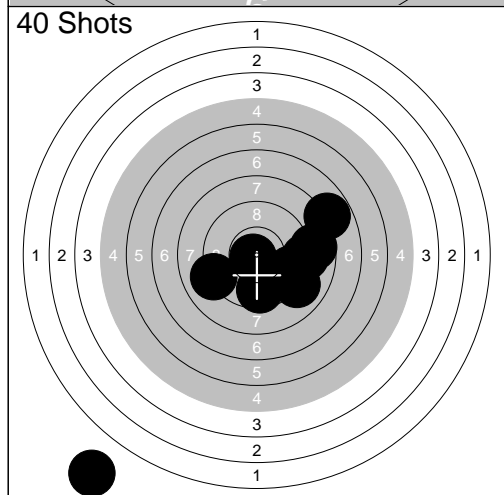

11:	8.7	→
12:	9.1	←
13:	9.0	↘
14:	*10.8	←
15:	9.5	↘
16:	9.1	→
17:	7.8	↗
18:	10.1	↘
19:	0.0	↙
20:	9.6	↓
Series		80.0
Total		168.0

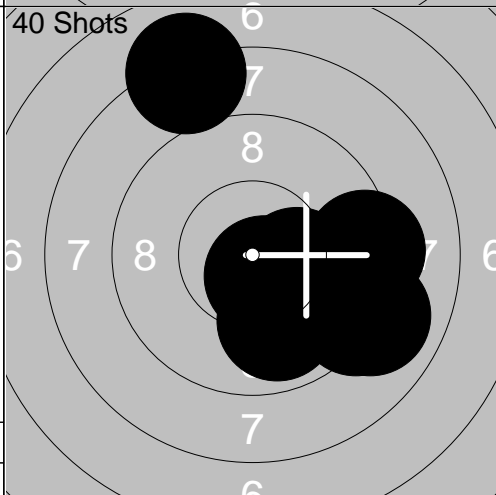

21:	9.8	↘
22:	8.1	↗
23:	9.0	↘
24:	*10.3	→
25:	9.3	↘
26:	9.9	↙
27:	9.2	↘
28:	9.3	→
29:	9.6	→
30:	*10.6	↘
Series		91.0
Total		259.0

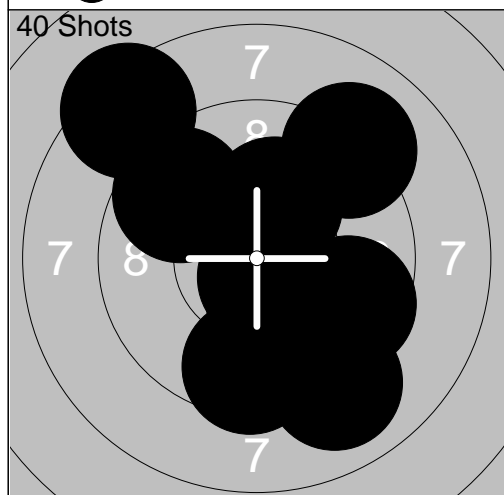

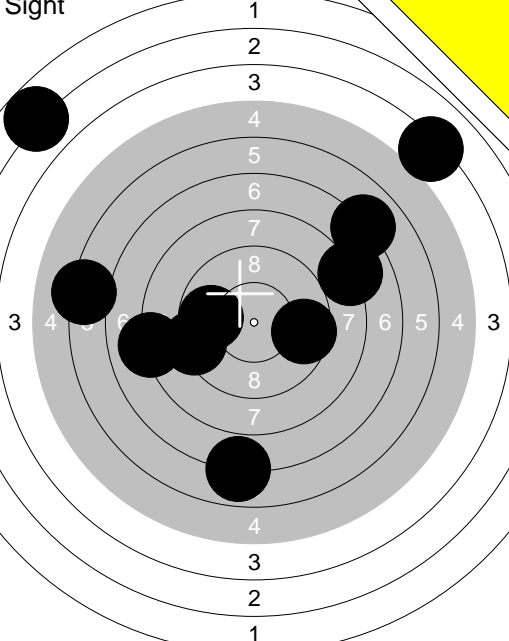

31:	10.0	↘
32:	8.4	↗
33:	9.1	↗
34:	9.5	↘
35:	9.6	↗
36:	*10.7	↙
37:	9.6	↘
38:	9.0	↘
39:	*10.2	↗
40:	*10.2	↘
Series		93.0
Total		352.0

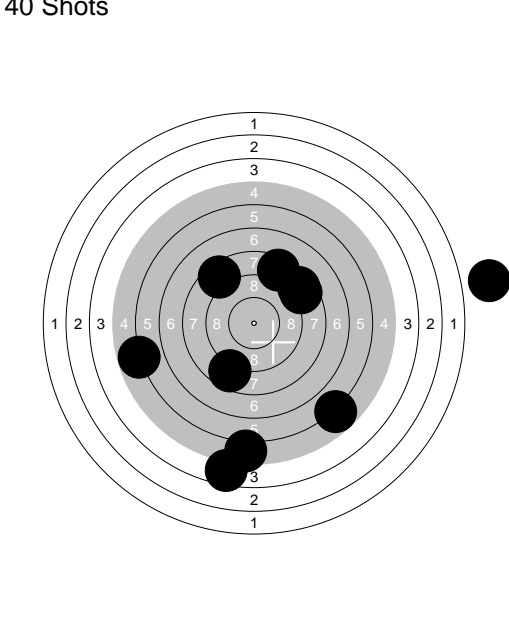
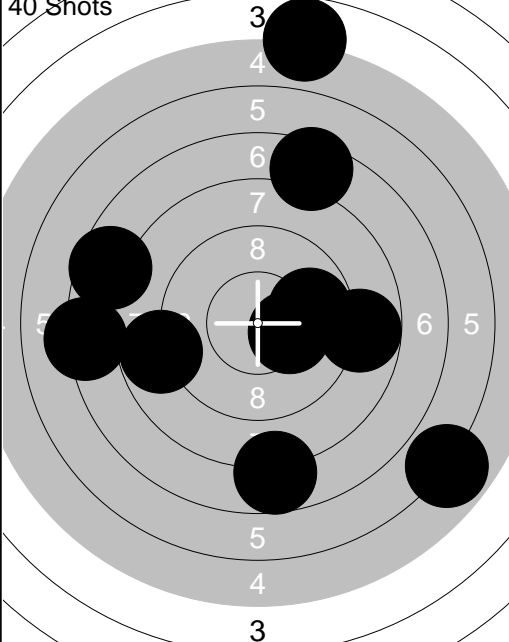
<p>Sight</p> 	<p>1: 8.0 ←</p> <p>2: 9.8 ←</p> <p>3: 9.5 →</p> <p>4: 4.1 ↗</p> <p>5: 8.0 →</p> <p>6: 7.0 ↗</p> <p>7: 9.2 ←</p> <p>8: 2.7 ↗</p> <p>9: 6.9 ↓</p> <p>10: 6.2 ←</p> <hr/> <p>Series 68.0</p> <hr/> <p>Total 0.0</p>	<p>Sight</p> 	<p>11: 7.5 →</p> <p>12: 5.9 →</p> <hr/> <p>Series 12.0</p> <hr/> <p>Total 0.0</p>
--	--	--	---

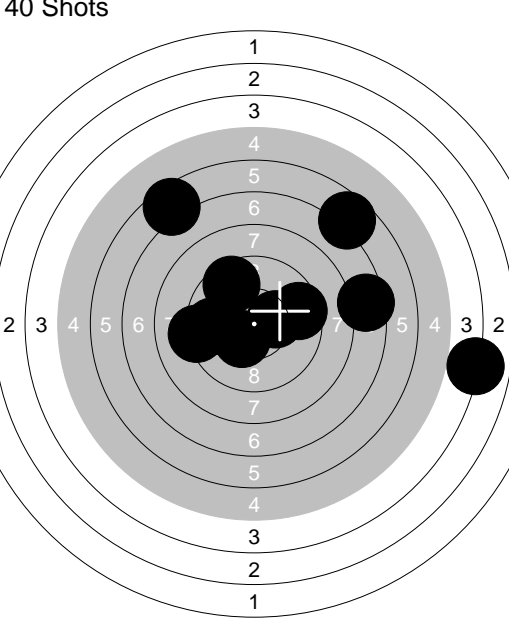
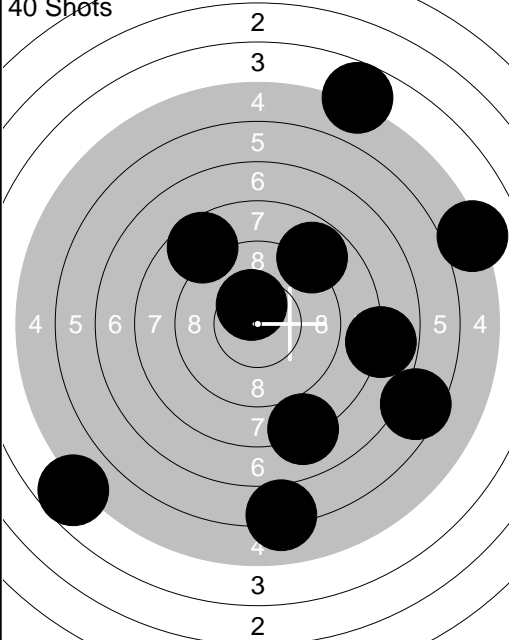
<p>40 Shots</p> 	<p>1: 5.4 ↓</p> <p>2: 8.5 ↗</p> <p>3: 0.0 →</p> <p>4: 8.6 ↗</p> <p>5: 4.5 ↓</p> <p>6: 5.8 ↓</p> <p>7: 8.5 ↗</p> <p>8: 5.8 ←</p> <p>9: 8.4 ↗</p> <p>10: 8.6 ↓</p> <hr/> <p>Series 59.0</p> <hr/> <p>Total 59.0</p>	<p>40 Shots</p> 	<p>11: 7.2 ←</p> <p>12: 7.7 ↓</p> <p>13: *10.2 →</p> <p>14: 8.8 →</p> <p>15: 7.4 ↗</p> <p>16: 7.6 ←</p> <p>17: 9.8 →</p> <p>18: 5.9 ↘</p> <p>19: 8.8 ←</p> <p>20: 4.8 ↑</p> <hr/> <p>Series 72.0</p> <hr/> <p>Total 131.0</p>
--	---	--	---

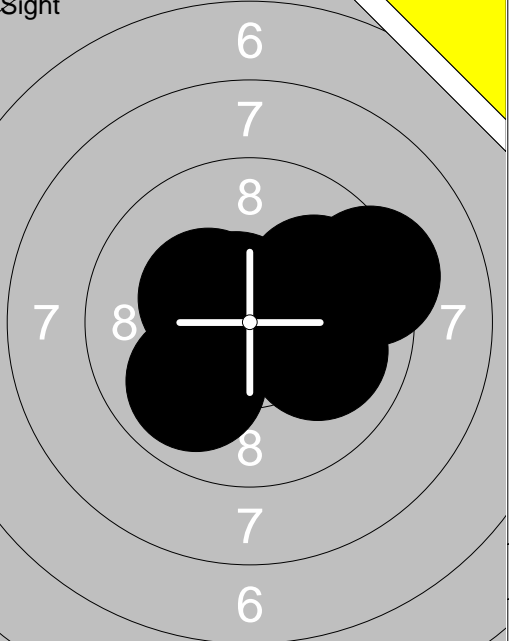

<p>40 Shots</p> 	<p>21: 9.5 ↗</p> <p>22: *10.3 →</p> <p>23: *10.4 ↓</p> <p>24: 6.5 ↗</p> <p>25: 6.6 ↗</p> <p>26: 9.7 ←</p> <p>27: 9.1 ←</p> <p>28: 3.9 →</p> <p>29: 7.4 →</p> <p>30: 9.5 →</p> <hr/> <p>Series 78.0</p> <hr/> <p>Total 209.0</p>	<p>40 Shots</p> 	<p>31: 8.6 ↗</p> <p>32: 6.5 →</p> <p>33: 4.7 ↘</p> <p>34: 5.1 →</p> <p>35: 8.1 ↓</p> <p>36: 7.8 →</p> <p>37: 8.8 ↗</p> <p>38: 4.7 ↗</p> <p>39: *10.4 ↑</p> <p>40: 6.1 ↓</p> <hr/> <p>Series 66.0</p> <hr/> <p>Total 275.0</p>
---	---	---	---

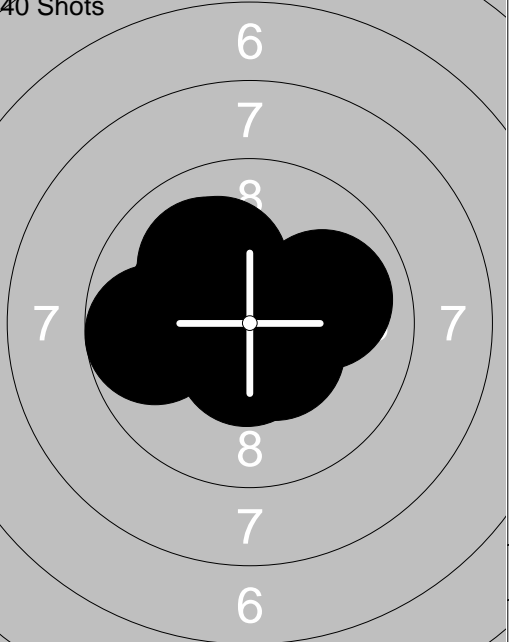

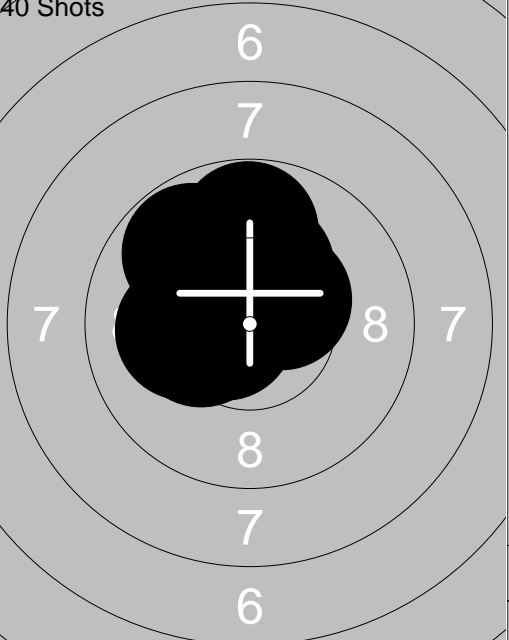
<p>Sight</p> 	<p>1: 9.9 →</p> <p>2: 9.6 ↗</p> <p>3: 10.0 ↗</p> <p>4: *10.4 ↓</p> <p>5: *10.2 ↙</p> <p>6: *10.2 ↑</p> <p>7: 9.7 ↑</p> <p>8: *10.3 →</p> <p>9: *10.3 ↗</p> <p>10: 9.7 ↘</p>	<p>Sight</p> 		<p>11: 10.0 →</p> <p>12: 9.9 ↙</p> <p>13: 10.0 ↗</p> <p>14: *10.3 ↙</p> <p>15: *10.6 ↗</p> <p>16: 9.3 →</p> <p>17: *10.9 →</p> <p>18: *10.7 ↙</p>	
Series 96.0				Series 78.0	
Total 0.0				Total 0.0	

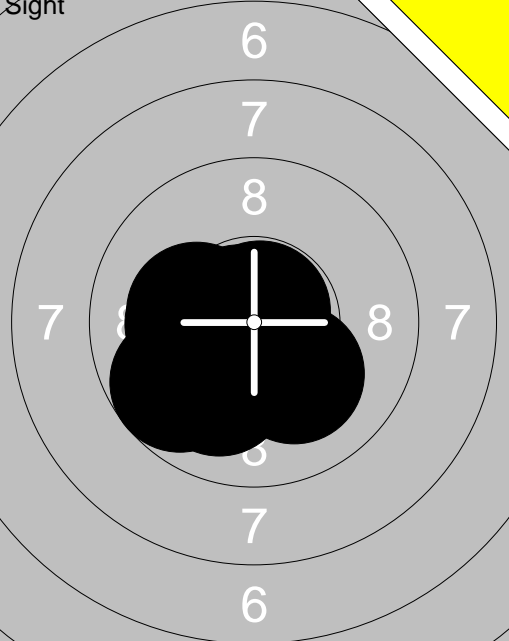
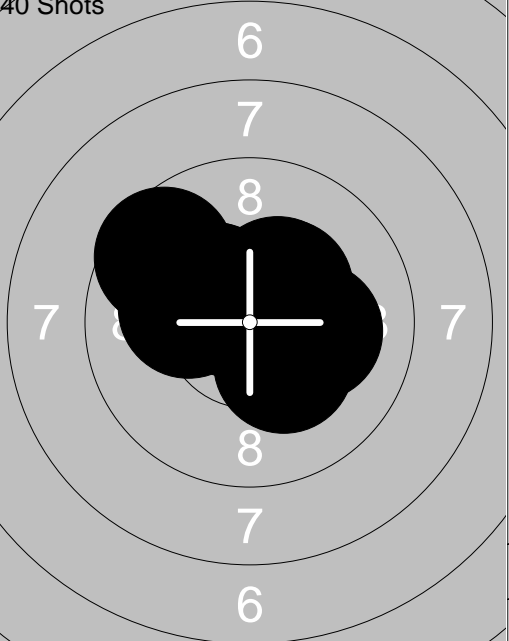
<p>40 Shots</p> 	<p>1: 10.1 ↑</p> <p>2: *10.3 ↓</p> <p>3: *10.7 ↗</p> <p>4: *10.5 →</p> <p>5: 9.4 ↑</p> <p>6: 9.9 ↗</p> <p>7: 9.6 →</p> <p>8: 9.9 →</p> <p>9: *10.6 ↙</p> <p>10: *10.6 ↑</p>	<p>40 Shots</p> 		<p>11: *10.5 ↘</p> <p>12: *10.5 ↓</p> <p>13: 10.1 ↗</p> <p>14: 9.7 ←</p> <p>15: *10.3 ↙</p> <p>16: *10.6 ←</p> <p>17: *10.2 ↙</p> <p>18: 10.0 →</p> <p>19: *10.3 ←</p> <p>20: 10.1 ↗</p>	
Series 96.0				Series 99.0	
Total 96.0				Total 195.0	

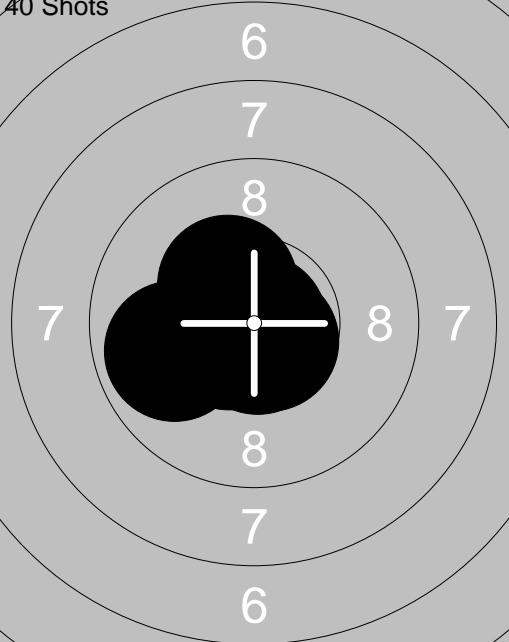
<p>40 Shots</p> 	<p>21: 9.3 ↑</p> <p>22: *10.3 ↑</p> <p>23: *10.4 ↙</p> <p>24: *10.3 ↗</p> <p>25: *10.9 ←</p> <p>26: 9.9 →</p> <p>27: *10.4 ↑</p> <p>28: *10.4 ←</p> <p>29: *10.9 ↓</p> <p>30: *10.8 ↘</p>	<p>40 Shots</p> 		<p>31: *10.6 ←</p> <p>32: 9.8 ↗</p> <p>33: 10.1 ←</p> <p>34: *10.4 ↙</p> <p>35: *10.3 ←</p> <p>36: *10.5 ↑</p> <p>37: 9.8 ↑</p> <p>38: *10.2 ↑</p> <p>39: *10.4 ↗</p> <p>40: *10.2 ↑</p>	
Series 98.0				Series 98.0	
Total 293.0				Total 391.0	

<p>Sight</p> 	<p>40 Shots</p> 	
<p>1: *10.8 ↗</p> <p>2: 10.1 ↘</p> <p>3: *10.2 ←</p> <p>4: 10.1 ↙</p> <p>5: *10.5 ←</p> <p>6: *10.7 ↖</p> <p>7: 9.7 ↘</p> <p>8: *10.2 ←</p> <p>9: *10.6 ↓</p> <p>10: 10.0 ↘</p>	<p>1: *10.3 ↘</p> <p>2: *10.3 ↗</p> <p>3: *10.4 ↗</p> <p>4: 10.1 →</p> <p>5: *10.3 ↗</p> <p>6: 10.1 ←</p> <p>7: *10.7 ↗</p> <p>8: *10.4 ↗</p> <p>9: *10.8 ↗</p> <p>10: 9.6 ↗</p>	
Series 99.0	Series 99.0	
Total 0.0	Total 99.0	

<p>40 Shots</p> 	<p>40 Shots</p> 	
<p>11: *10.6 ↙</p> <p>12: 9.9 ←</p> <p>13: *10.7 ↘</p> <p>14: *10.6 ←</p> <p>15: *10.5 ←</p> <p>16: *10.5 ←</p> <p>17: *10.5 ↗</p> <p>18: *10.7 ↓</p> <p>19: *10.4 ↗</p> <p>20: *10.9 →</p>	<p>21: *10.6 ↓</p> <p>22: *10.6 ↙</p> <p>23: 9.9 ↓</p> <p>24: *10.7 ↗</p> <p>25: *10.7 ↖</p> <p>26: *10.5 ↘</p> <p>27: 10.1 →</p> <p>28: *10.4 ←</p> <p>29: *10.2 ←</p> <p>30: *10.4 ↓</p>	
Series 99.0	Series 99.0	
Total 198.0	Total 297.0	

<p>40 Shots</p> 	<p>40 Shots</p> 	
<p>31: *10.3 ↙</p> <p>32: *10.6 ↙</p> <p>33: 9.8 ↓</p> <p>34: *10.4 →</p> <p>35: *10.5 ↓</p> <p>36: *10.6 ↓</p> <p>37: 9.9 ↓</p> <p>38: 10.0 ↘</p> <p>39: *10.4 ←</p> <p>40: *10.3 ↗</p>		
Series 98.0		
Total 395.0		

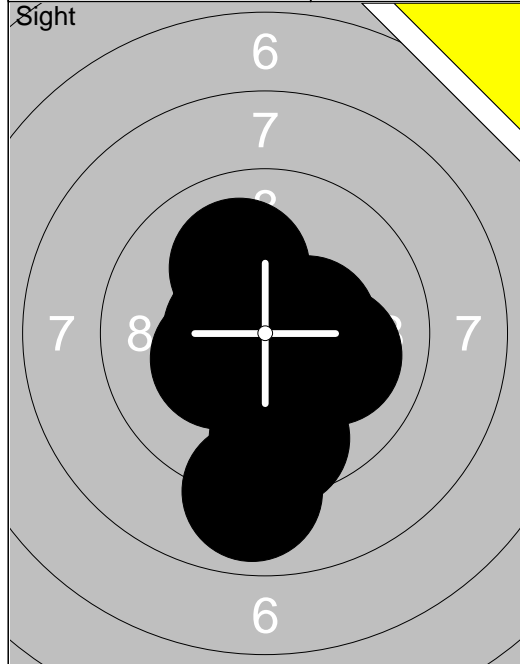

1:	*10.5	→
2:	10.1	↗
3:	*10.4	→
4:	*10.4	↖
5:	9.6	↓
6:	*10.4	↓
7:	*10.5	←
8:	8.9	↓
9:	10.1	→
10:	*10.3	↙
Series	97.0	
Total	0.0	

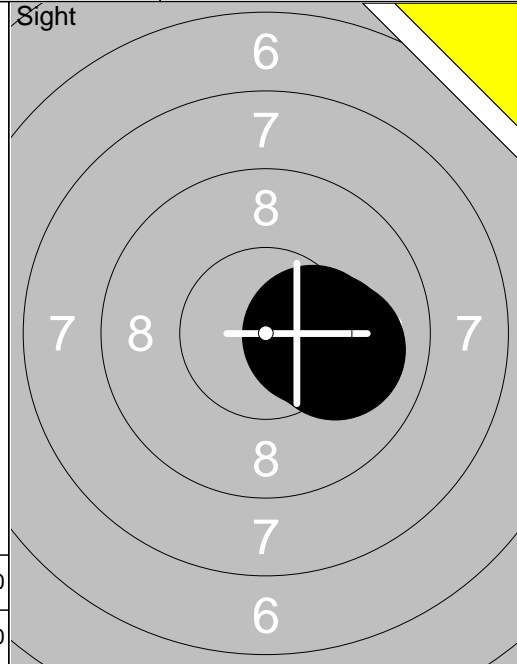

11:	*10.2	→
12:	*10.4	→
13:	10.0	→
Series	30.0	
Total	0.0	

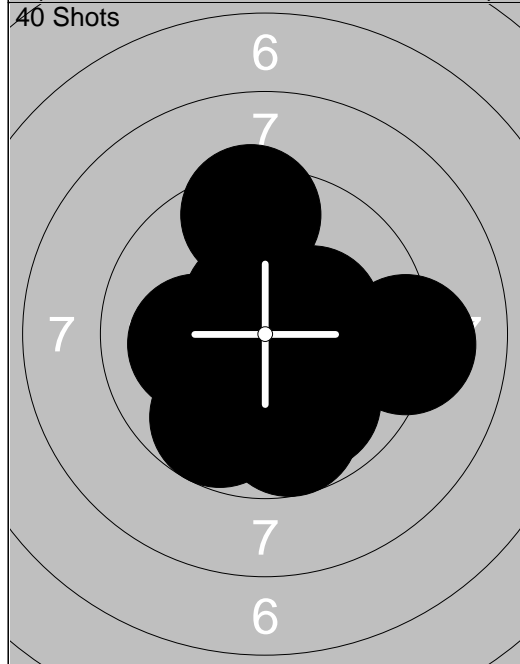

1:	9.1	→
2:	*10.6	↗
3:	*10.5	↖
4:	9.7	↓
5:	9.7	↓
6:	9.9	↓
7:	*10.3	→
8:	*10.7	↗
9:	10.1	←
10:	9.4	↑
Series	95.0	
Total	95.0	

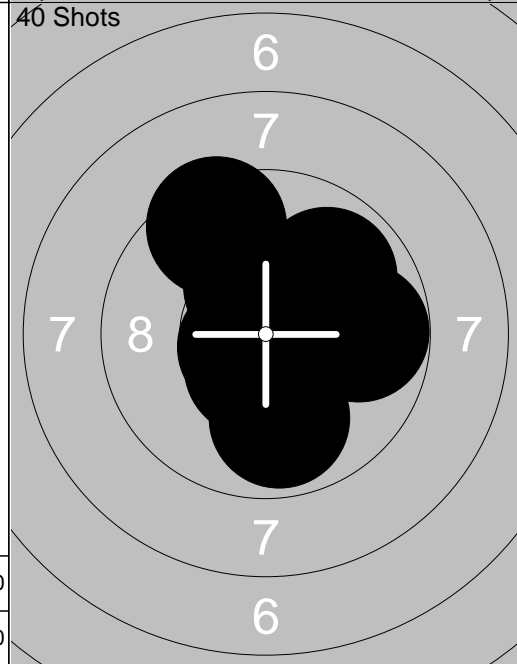

11:	*10.5	↓
12:	*10.3	↖
13:	*10.7	↗
14:	10.0	→
15:	10.1	↗
16:	9.4	↖
17:	*10.7	↙
18:	9.8	→
19:	9.9	↓
20:	9.9	↗
Series	96.0	
Total	191.0	

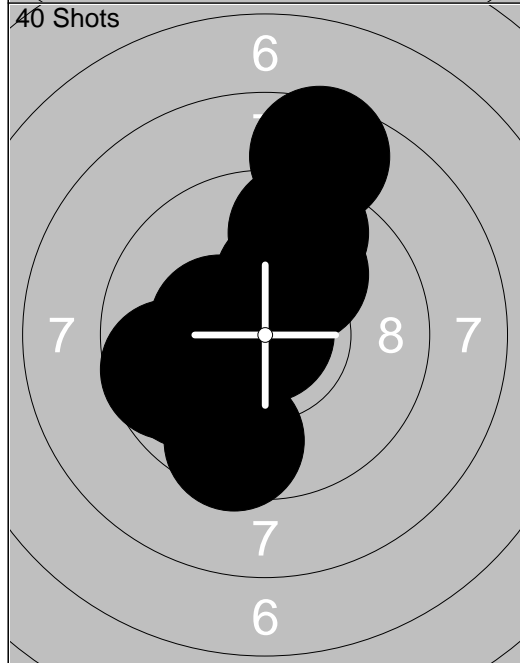

21:	*10.6	←
22:	9.5	↓
23:	9.7	←
24:	9.9	↙
25:	10.1	↗
26:	9.6	↗
27:	8.6	↗
28:	*10.9	↖
29:	*10.4	←
30:	*10.2	↑
Series	94.0	
Total	285.0	

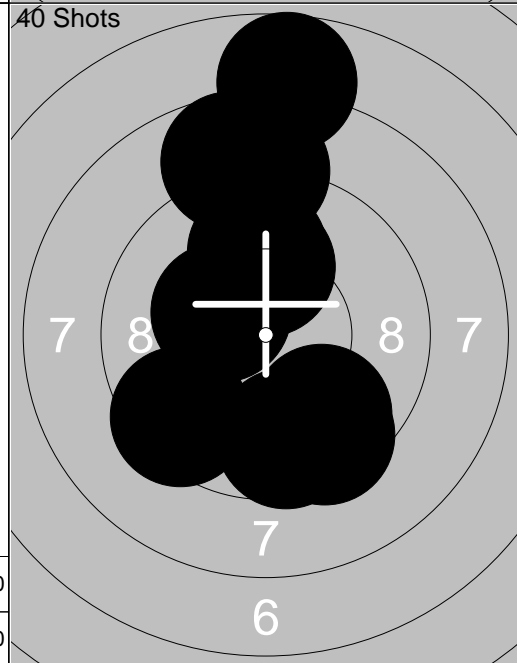

31:	9.7	↓
32:	9.5	↓
33:	8.9	↑
34:	7.7	↑
35:	10.1	↑
36:	9.6	↓
37:	9.9	↑
38:	8.7	↑
39:	*10.3	↙
40:	9.4	↙
Series	88.0	
Total	373.0	

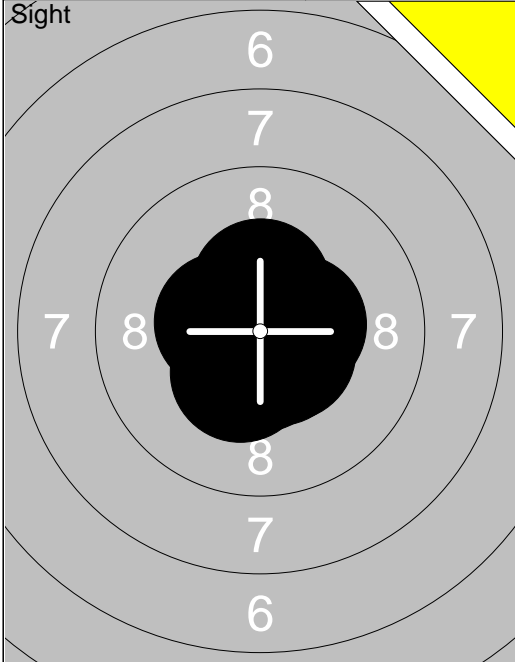

1:	*10.4	↑
2:	*10.5	←
3:	*10.6	↓
4:	*10.4	↙
5:	*10.6	↘
6:	*10.5	↑
7:	*10.5	↘
8:	*10.5	→
9:	*10.7	←
Series		90.0
Total		0.0

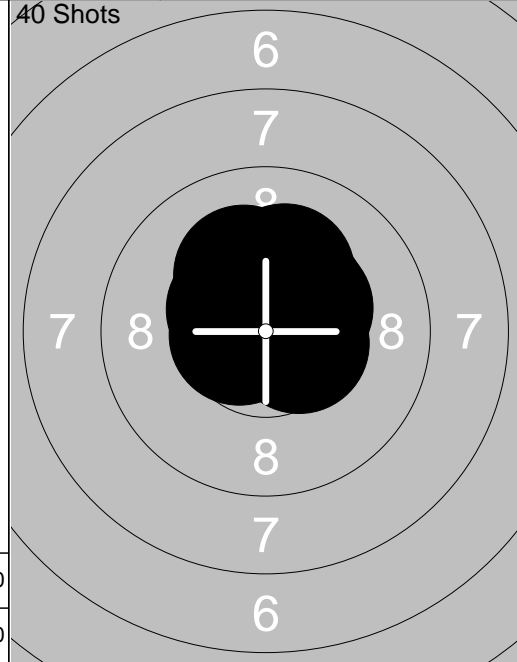

1:	*10.2	↑
2:	*10.4	↗
3:	*10.5	↖
4:	*10.9	↖
5:	*10.4	↗
6:	*10.6	←
7:	*10.7	→
8:	*10.5	→
9:	*10.6	↑
10:	*10.2	↑
Series		100.0
Total		100.0

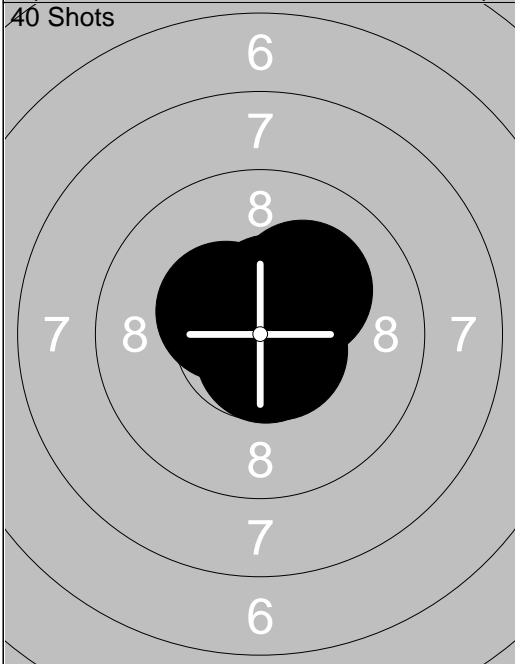

11:	*10.8	→
12:	*10.7	↓
13:	*10.2	↗
14:	*10.8	↘
15:	*10.8	↗
16:	*10.7	↑
17:	*10.7	↓
18:	*10.4	↖
19:	*10.6	↑
20:	*10.8	→
Series		100.0
Total		200.0

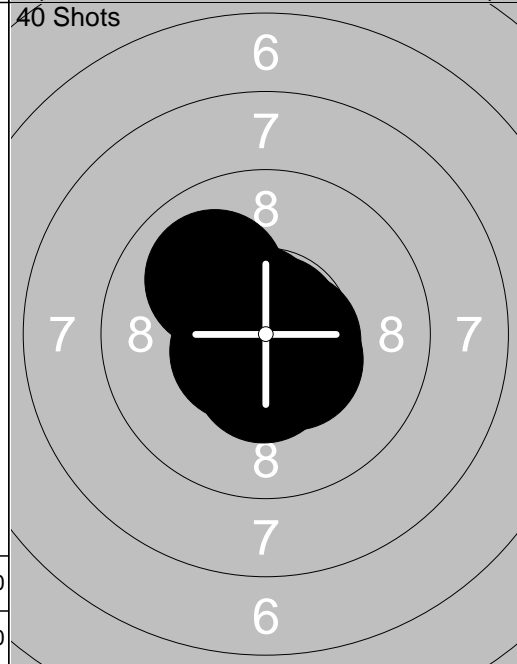

21:	*10.8	↗
22:	*10.6	↖
23:	*10.6	→
24:	*10.8	↘
25:	*10.5	↓
26:	*10.5	↘
27:	*10.7	←
28:	10.0	↖
29:	*10.6	↓
30:	*10.7	↖
Series		100.0
Total		300.0

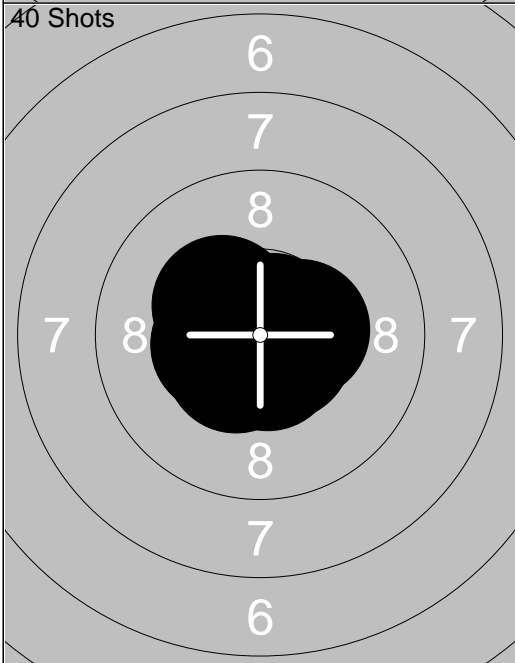

31:	*10.4	↖
32:	*10.6	↘
33:	*10.6	↓
34:	*10.4	→
35:	*10.5	↘
36:	*10.8	→
37:	*10.3	↖
38:	*10.4	←
39:	*10.5	↘
40:	*10.7	↗
Series		100.0
Total		400.0

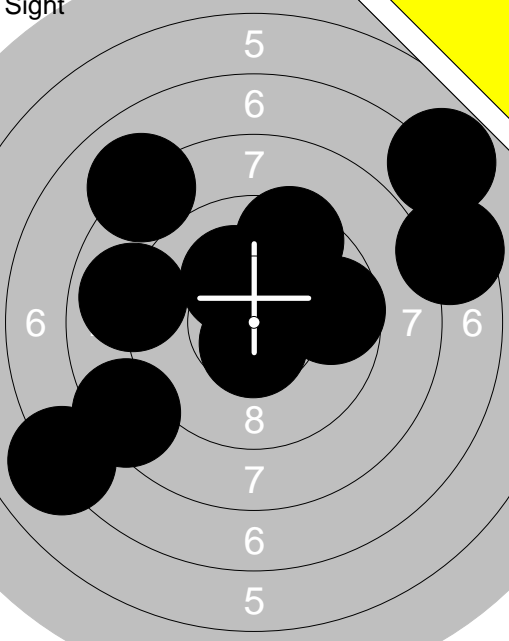
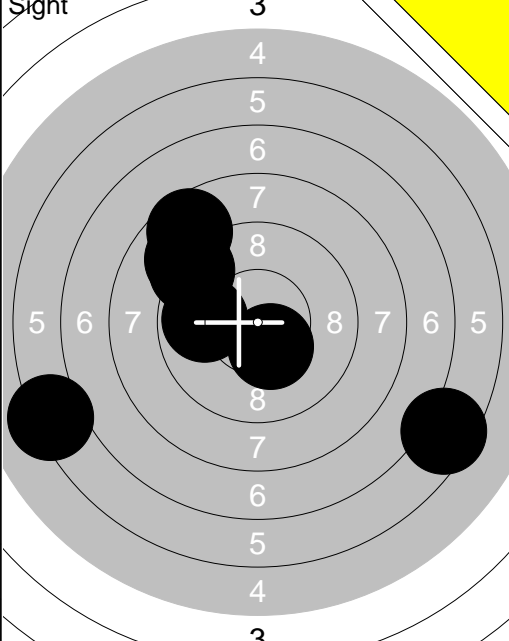
<p>Sight</p> 	<p>Sight</p> 	
<p>1: 8.4 ↙</p> <p>2: *10.2 ↗</p> <p>3: 9.5 ↗</p> <p>4: 8.9 ↖</p> <p>5: 6.9 ↗</p> <p>6: 8.0 ↗</p> <p>7: *10.6 ↓</p> <p>8: 9.7 →</p> <p>9: 7.0 ↖</p> <p>10: 7.5 →</p>	<p>11: 9.0 ↗</p> <p>12: 9.2 ↗</p> <p>13: 6.5 ↘</p> <p>14: *10.4 ↘</p> <p>15: 8.6 ↗</p> <p>16: 9.8 ↖</p> <p>17: 6.2 ↖</p>	
Series 82.0	Series 57.0	
Total 0.0	Total 0.0	

<p>40 Shots</p> 	<p>40 Shots</p> 	
<p>1: 9.0 ↘</p> <p>2: *10.6 ↗</p> <p>3: 8.6 →</p> <p>4: 9.8 ↓</p> <p>5: 9.0 ↓</p> <p>6: 9.8 ↓</p> <p>7: 9.4 ↖</p> <p>8: *10.8 ↗</p> <p>9: *10.6 ↘</p> <p>10: 8.9 ↖</p>	<p>11: 9.9 ↖</p> <p>12: 9.1 ↖</p> <p>13: *10.6 ↓</p> <p>14: *10.2 ↗</p> <p>15: 8.8 ↖</p> <p>16: 9.6 ↖</p> <p>17: 7.1 ↗</p> <p>18: *10.9 →</p> <p>19: 8.4 ↗</p> <p>20: 9.8 ↖</p>	
Series 91.0	Series 89.0	
Total 91.0	Total 180.0	

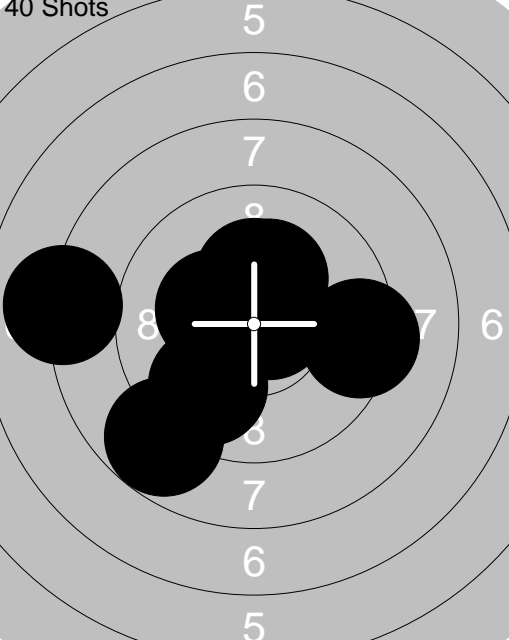
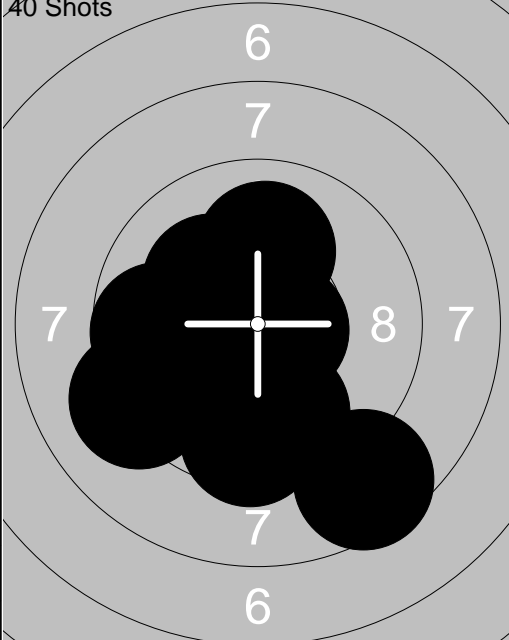
<p>40 Shots</p> 	<p>40 Shots</p> 	
<p>21: *10.7 →</p> <p>22: 9.3 →</p> <p>23: *10.2 ↗</p> <p>24: 9.8 ↘</p> <p>25: *10.3 ↗</p> <p>26: *10.5 ↖</p> <p>27: 8.8 ↘</p> <p>28: *10.5 ↗</p> <p>29: *10.3 ↖</p> <p>30: 8.0 ↖</p>	<p>31: *10.5 ↖</p> <p>32: 8.5 ↘</p> <p>33: 9.2 ↖</p> <p>34: *10.7 →</p> <p>35: *10.2 ↗</p> <p>36: 9.5 ↓</p> <p>37: 10.0 ↗</p> <p>38: 9.8 ↘</p> <p>39: 9.7 ↖</p> <p>40: *10.6 ↖</p>	
Series 94.0	Series 94.0	
Total 274.0	Total 368.0	

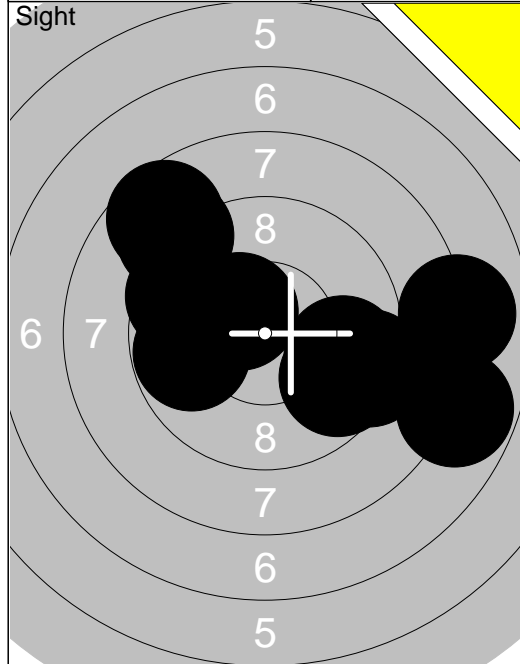

Sight

1:	8.9	↗
2:	8.6	↗
3:	9.6	↖
4:	9.8	←
5:	7.8	↘
6:	9.6	↘
7:	9.7	→
8:	8.0	→
9:	*10.4	↗
10:	9.3	→
Series		86.0
Total		0.0

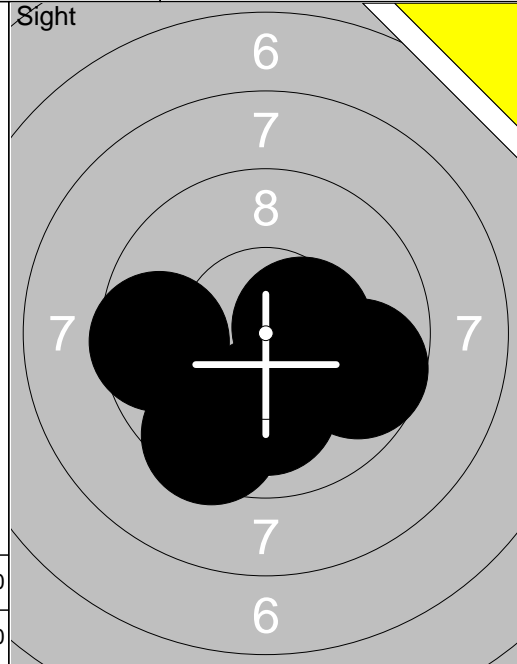

Sight

11:	9.7	→
12:	9.6	←
13:	9.5	↙
14:	10.0	↓
15:	*10.5	→
Series		47.0
Total		0.0

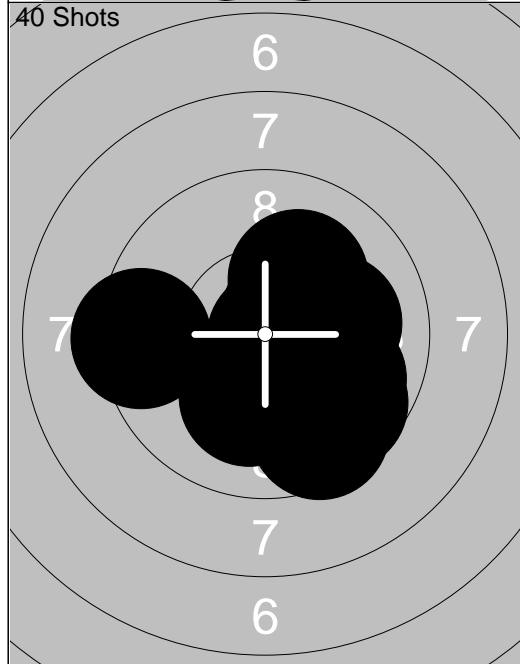

40 Shots

1:	9.9	↘
2:	10.1	→
3:	9.4	←
4:	9.7	↘
5:	*10.3	↘
6:	10.1	↗
7:	9.5	↘
8:	10.1	↓
9:	*10.5	↗
10:	*10.8	→
Series		96.0
Total		96.0

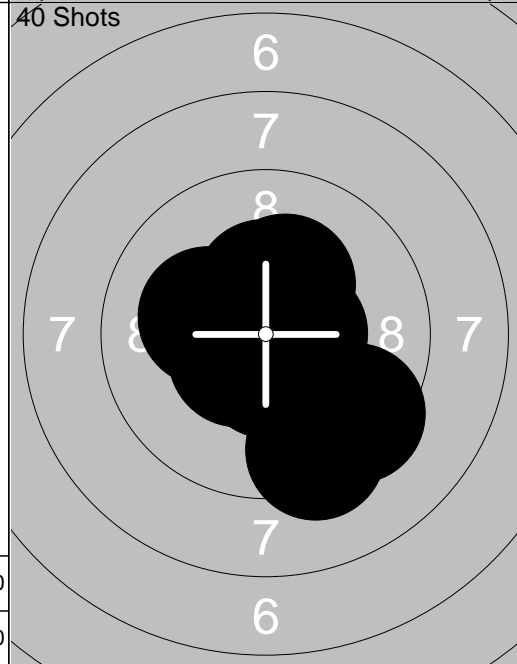

40 Shots

11:	*10.5	↓
12:	*10.3	↗
13:	*10.3	↘
14:	*10.4	↑
15:	9.3	↘
16:	*10.5	→
17:	*10.6	←
18:	*10.5	↙
19:	9.4	↘
20:	*10.2	←
Series		98.0
Total		194.0

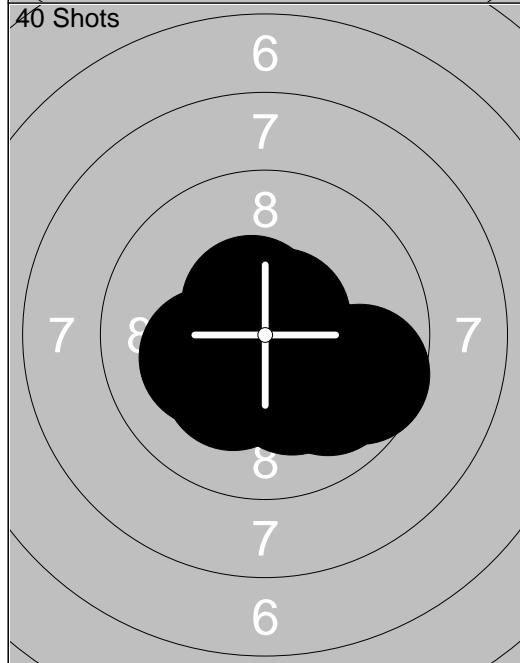

40 Shots

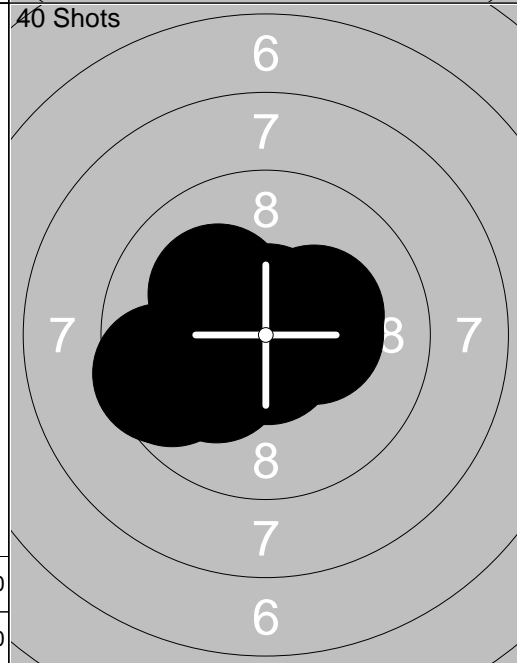

21:	*10.2	↘
22:	*10.7	↗
23:	9.9	↘
24:	*10.6	↓
25:	9.6	→
26:	*10.4	↙
27:	*10.2	↘
28:	*10.2	←
29:	*10.2	↙
30:	*10.5	↗
Series		98.0
Total		292.0



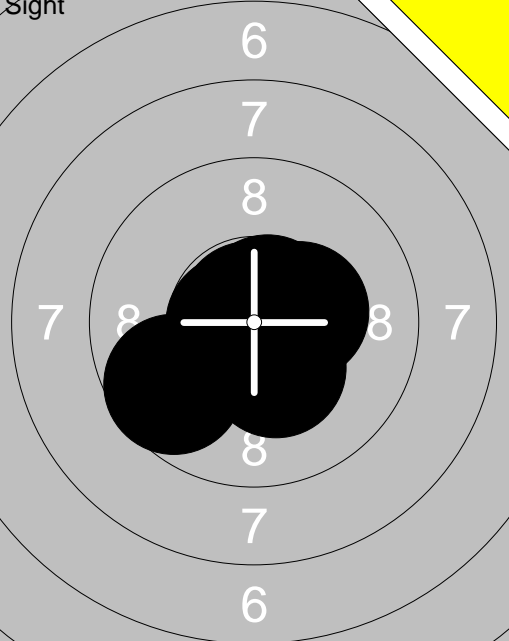
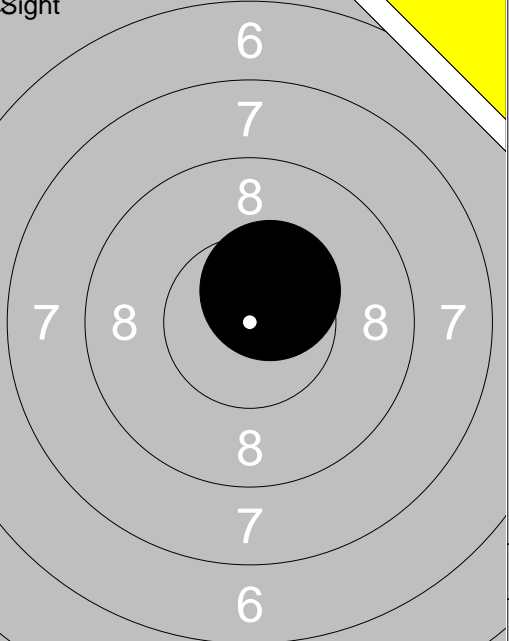

40 Shots

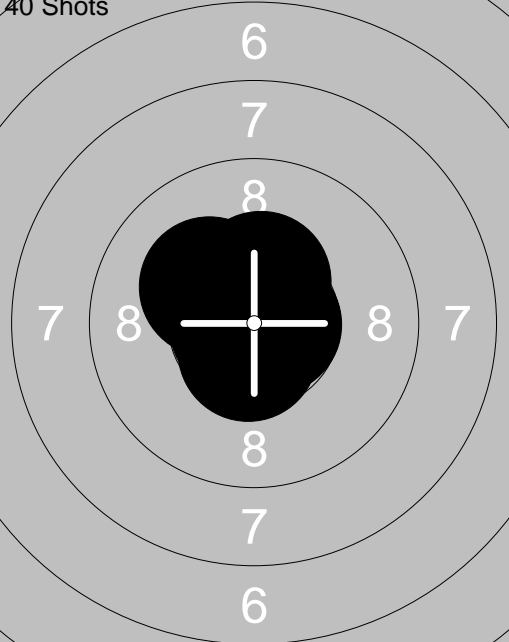
31:	*10.9	↓
32:	*10.3	→
33:	*10.3	↗
34:	*10.2	↙
35:	*10.7	↑
36:	9.6	←
37:	9.5	←
38:	*10.6	←
39:	*10.2	↖
40:	*10.7	↓
Series		98.0
Total		390.0

<p>Sight</p> 	<p>1: 9.7 ↙</p> <p>2: *10.7 ↗</p> <p>3: *10.8 ↖</p> <p>4: *10.4 →</p> <p>5: *10.8 ↗</p> <p>6: *10.6 →</p> <p>7: *10.7 ←</p> <p>8: *10.5 ↓</p> <p>9: *10.8 ←</p> <p>10: *10.3 ↓</p>	<p>Sight</p> 	<p>11: *10.5 ↗</p>
Series	99.0	Series	10.0
Total	0.0	Total	0.0

<p>40 Shots</p> 	<p>1: *10.4 ↗</p> <p>2: *10.7 →</p> <p>3: *10.7 →</p> <p>4: *10.8 →</p> <p>5: *10.7 ↓</p> <p>6: *10.6 ↓</p> <p>7: *10.7 ↓</p> <p>8: *10.8 ←</p> <p>9: *10.7 ↖</p> <p>10: *10.2 ↖</p>	<p>40 Shots</p> 	<p>11: *10.4 ↓</p> <p>12: *10.7 ←</p> <p>13: *10.3 ↖</p> <p>14: *10.9 ↗</p> <p>15: *10.8 →</p> <p>16: *10.8 ←</p> <p>17: *10.4 ↓</p> <p>18: *10.3 ↓</p> <p>19: *10.8 ↖</p> <p>20: *10.6 ↖</p>
Series	100.0	Series	100.0
Total	100.0	Total	200.0

<p>40 Shots</p> 	<p>21: *10.8 ↗</p> <p>22: *10.5 ↙</p> <p>23: *10.6 ↖</p> <p>24: *10.7 ↓</p> <p>25: 10.1 ↗</p> <p>26: *10.3 ←</p> <p>27: *10.3 ↗</p> <p>28: *10.6 ↗</p> <p>29: *10.5 ↖</p> <p>30: *10.5 ←</p>	<p>40 Shots</p> 	<p>31: *10.6 ↗</p> <p>32: *10.7 →</p> <p>33: *10.7 ↗</p> <p>34: *10.6 →</p> <p>35: *10.5 ↓</p> <p>36: *10.7 ←</p> <p>37: *10.5 ↓</p> <p>38: *10.6 →</p> <p>39: *10.6 ↓</p> <p>40: *10.9 ↖</p>
Series	100.0	Series	100.0
Total	300.0	Total	400.0

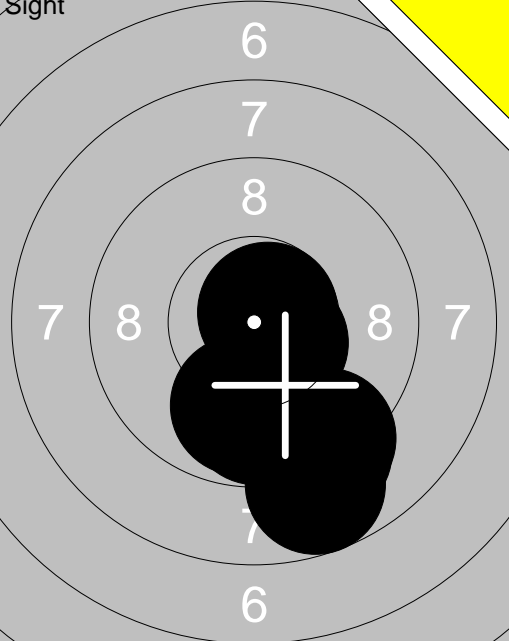
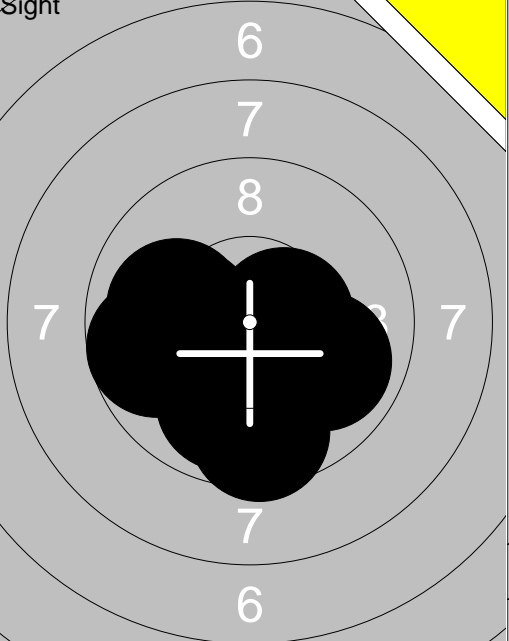
<p>Sight</p> 	<p>Sight</p> 
<p>1: 9.3 ↘ 2: *10.5 ↘ 3: 9.8 ↓ 4: 9.9 ↓ 5: 9.1 ↓ 6: 8.7 ↓ 7: 10.1 ↓ 8: 9.2 ↓ 9: 9.7 ↓ 10: *10.7 ↗</p>	<p>11: 9.9 ↘ 12: 10.0 ← 13: *10.3 ↘ 14: 9.7 ← 15: 10.1 ← 16: 9.9 ↘ 17: 10.1 ↓ 18: *10.5 → 19: 9.6 ↓</p>
Series 92.0	Series 86.0
Total 0.0	Total 0.0

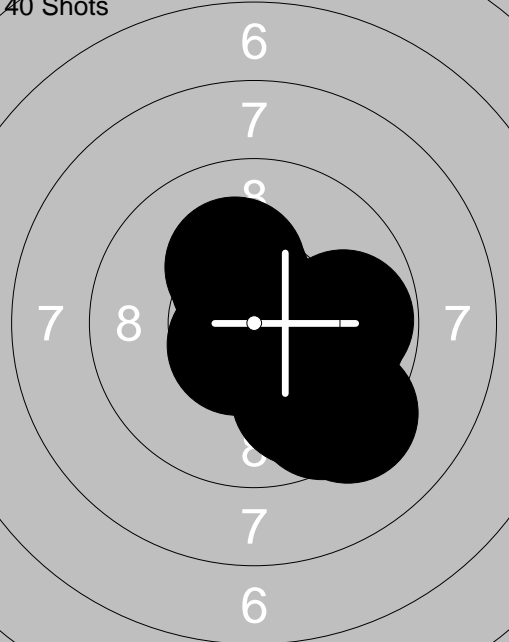
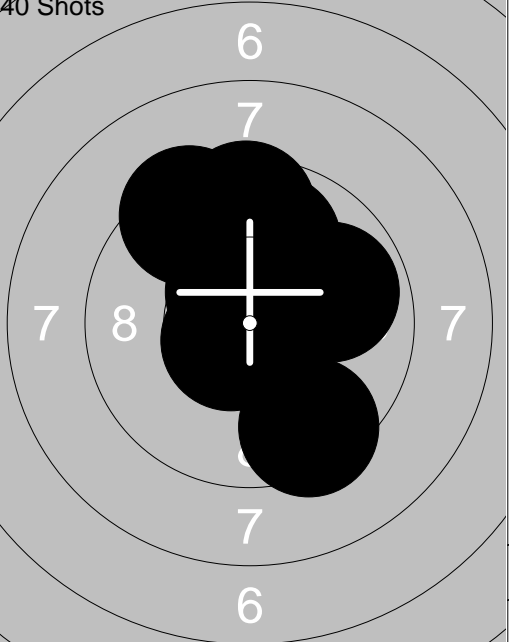
<p>40 Shots</p> 	<p>40 Shots</p> 
<p>1: 9.3 ↘ 2: 9.5 ↘ 3: *10.4 ↗ 4: *10.7 ↓ 5: 9.8 ↓ 6: *10.6 ↓ 7: 9.9 → 8: *10.6 → 9: *10.2 ↗ 10: 9.8 →</p>	<p>11: *10.7 → 12: 9.9 → 13: *10.6 ↙ 14: 9.4 ↗ 15: 9.5 ↑ 16: 9.4 ↓ 17: *10.6 ↑ 18: 9.9 ↑ 19: *10.5 ↗ 20: 9.9 ↑</p>
Series 95.0	Series 94.0
Total 95.0	Total 189.0

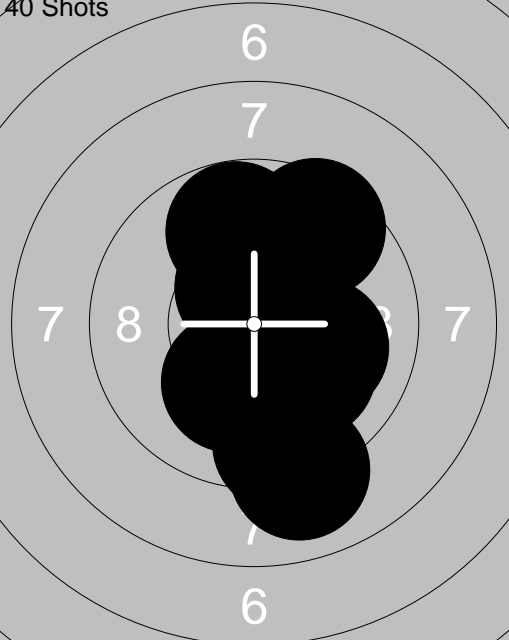
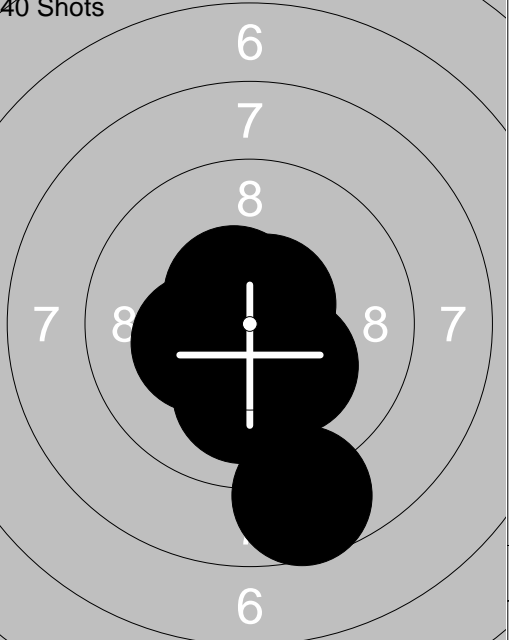
<p>40 Shots</p> 	<p>40 Shots</p> 
<p>21: 9.5 ↗ 22: 9.8 ↗ 23: 9.0 ↓ 24: 10.0 ↓ 25: 10.1 ↓ 26: 10.1 ↓ 27: *10.5 ↗ 28: 10.1 ↘ 29: 9.4 ↓ 30: *10.7 ↓</p>	<p>31: *10.3 ← 32: *10.7 ↙ 33: *10.5 ↗ 34: *10.7 ↓ 35: *10.2 ↘ 36: *10.8 ↗ 37: *10.2 ↓ 38: 10.1 ↓ 39: *10.6 ↗ 40: 8.7 ↓</p>
Series 96.0	Series 98.0
Total 285.0	Total 383.0

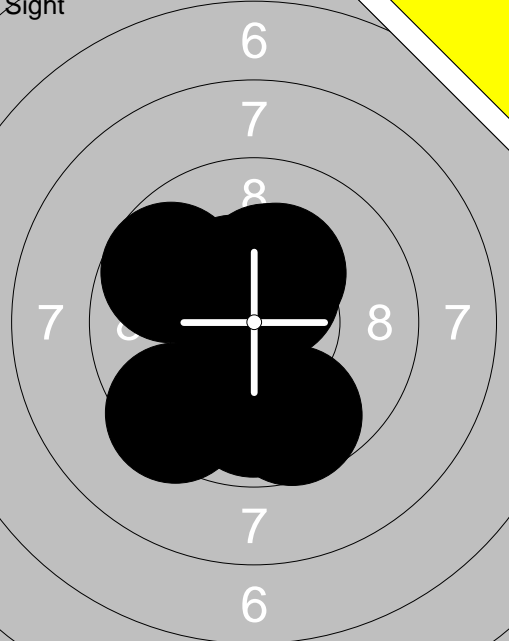
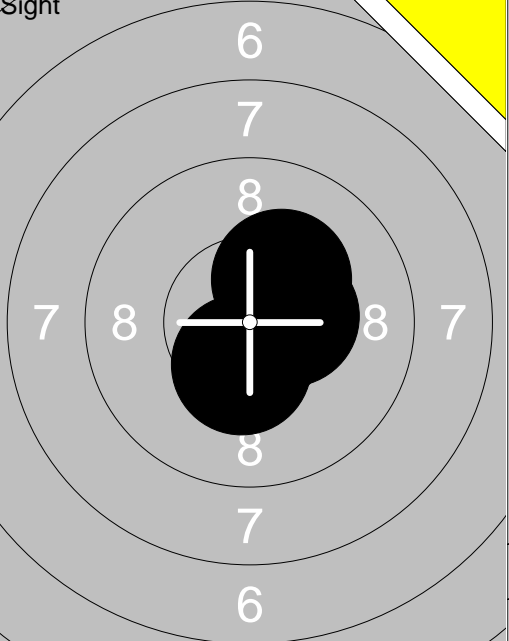
<p>Sight</p> 	<p>1: 9.7 ↓</p> <p>2: 9.9 ↓</p> <p>3: 9.4 ↙</p> <p>4: 9.7 ↖</p> <p>5: *10.3 ↑</p> <p>6: *10.4 ↗</p> <p>7: *10.4 ↗</p> <p>8: *10.7 ↑</p> <p>9: *10.3 ↑</p> <p>10: *10.5 ↗</p>	<p>Sight</p> 	<p>11: *10.3 ↗</p> <p>12: *10.4 →</p> <p>13: *10.4 ↓</p>
Series 96.0		Series 30.0	
Total 0.0		Total 0.0	

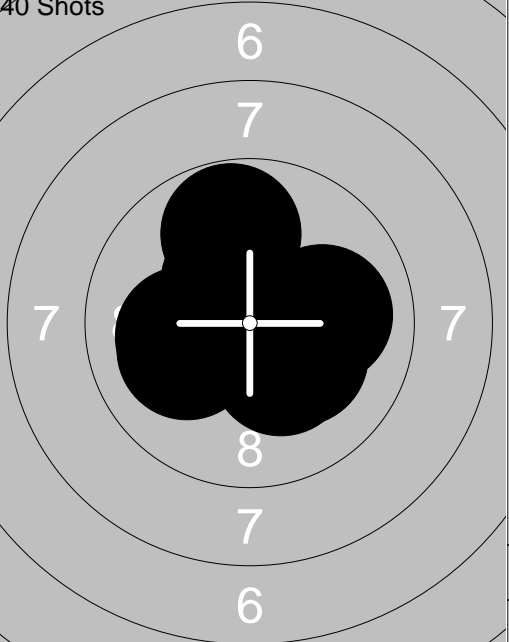
<p>40 Shots</p> 	<p>1: 9.6 ↓</p> <p>2: *10.3 ↓</p> <p>3: *10.2 ↓</p> <p>4: *10.5 ↗</p> <p>5: *10.5 ↓</p> <p>6: *10.5 ←</p> <p>7: *10.2 →</p> <p>8: *10.7 ←</p> <p>9: 10.0 ↓</p> <p>10: *10.3 ↙</p>	<p>40 Shots</p> 	<p>11: 10.1 ↖</p> <p>12: 10.0 →</p> <p>13: *10.9 ↗</p> <p>14: *10.3 ↓</p> <p>15: *10.2 ↓</p> <p>16: *10.4 ←</p> <p>17: *10.4 ↑</p> <p>18: *10.2 ↘</p> <p>19: 10.1 ←</p> <p>20: 9.8 ↑</p>
Series 99.0		Series 99.0	
Total 99.0		Total 198.0	

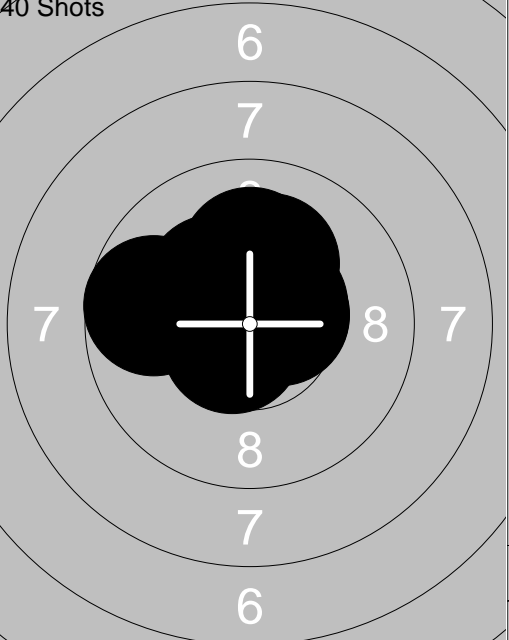
<p>40 Shots</p> 	<p>21: *10.6 ↑</p> <p>22: *10.6 →</p> <p>23: 10.1 ↖</p> <p>24: 9.9 ←</p> <p>25: 10.1 →</p> <p>26: 9.9 ↑</p> <p>27: *10.3 ↑</p> <p>28: *10.2 →</p> <p>29: *10.6 ↘</p> <p>30: *10.7 ↗</p>	<p>40 Shots</p> 	<p>31: *10.9 ↑</p> <p>32: 10.1 ↑</p> <p>33: *10.5 ↗</p> <p>34: 10.1 ↑</p> <p>35: *10.6 ↘</p> <p>36: *10.6 →</p> <p>37: *10.5 ↗</p> <p>38: 9.7 ←</p> <p>39: *10.3 ↖</p> <p>40: *10.6 →</p>
Series 98.0		Series 99.0	
Total 296.0		Total 395.0	

<p>Sight</p>	<p>Sight</p>	
1: 7.6 ← 2: 8.0 ← 3: 8.1 ← 4: 8.6 ← 5: *10.4 ← 6: 10.1 ↓ 7: 8.7 ← 8: 9.3 ↑ 9: 9.7 ↓ 10: 9.8 ←	11: 9.9 ↗ 12: 9.8 ↖ 13: *10.8 ↑ 14: 9.5 ↖ 15: 9.2 ↑ 16: 9.7 → 17: 9.5 ↑ 18: 9.6 → 19: *10.2 ↖ 20: 10.1 ↓	
Series 86.0	Series 93.0	
Total 0.0	Total 0.0	

<p>40 Shots</p>	<p>40 Shots</p>	
1: 8.5 ↑ 2: *10.4 ← 3: 9.9 ↑ 4: *10.6 ↖ 5: 9.1 ↗ 6: 9.1 ↑ 7: 10.1 ↓ 8: *10.6 ↓ 9: 10.1 ← 10: *10.7 ↙	11: 10.1 ↑ 12: *10.5 ← 13: 10.0 ↗ 14: *10.4 ↖ 15: 9.2 ↑ 16: 9.7 ← 17: *10.4 ↙ 18: *10.5 ↗ 19: 10.0 ← 20: 10.0 ↓	
Series 95.0	Series 98.0	
Total 95.0	Total 193.0	

<p>40 Shots</p>	<p>40 Shots</p>	
21: *10.5 ↗ 22: 8.7 ↑ 23: *10.7 → 24: *10.3 → 25: 9.9 ↓ 26: 10.1 ← 27: *10.4 ↑ 28: 9.8 ← 29: 10.1 ↓ 30: 8.9 ↗	31: 10.0 ↓ 32: *10.8 ↗ 33: *10.8 ↑ 34: 9.8 ↖ 35: *10.2 ↙ 36: *10.5 ↖ 37: *10.3 ↗ 38: 9.8 → 39: *10.2 ↓ 40: 8.8 ↑	
Series 94.0	Series 96.0	
Total 287.0	Total 383.0	

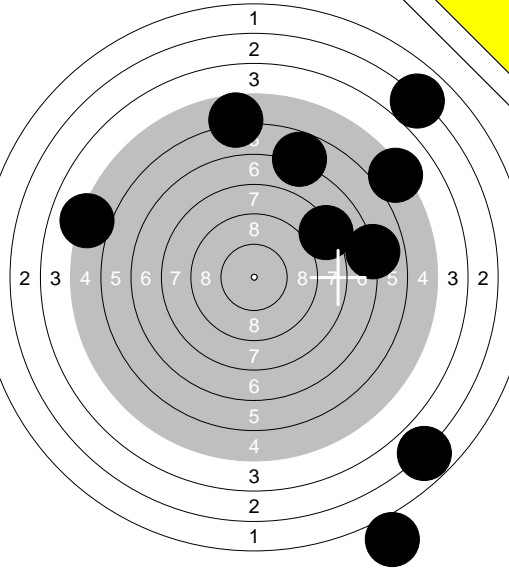
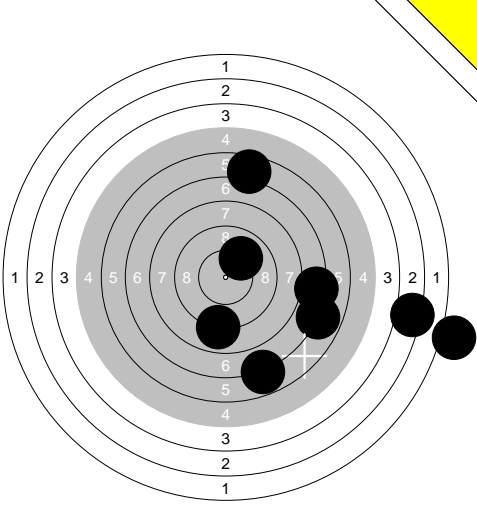
Sight 	1: 6.8 ↗ 2: 6.9 → 3: 5.7 ↗ 4: 3.0 ↗ 5: 5.2 ↗ 6: 0.0 ↓ 7: 2.8 ↓ 8: 8.1 ↗ 9: 1.1 ↓ 10: 5.1 ↖	Sight 	11: 6.5 ↗ 12: 7.2 → 13: 1.3 → 14: 0.0 ↓ 15: 6.8 ↓ 16: 8.9 ↓ 17: 6.8 → 18: 3.2 → 19: 10.0 ↗
Series 41.0		Series 47.0	
Total 0.0		Total 0.0	

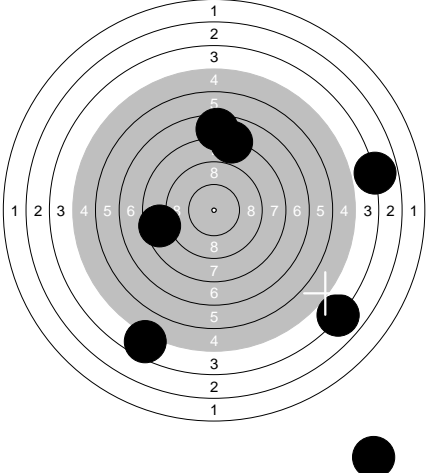
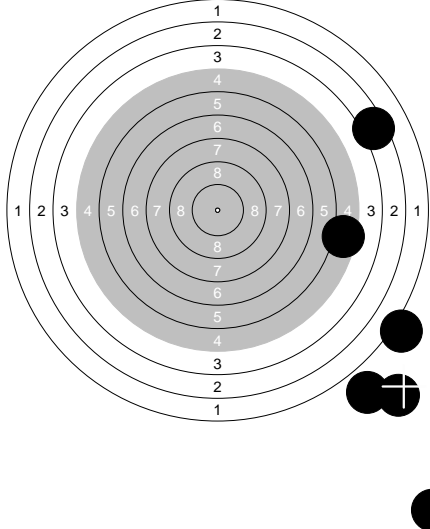
40 Shots 	1: 0.0 ↓ 2: 4.6 ↓ 3: 7.9 ↗ 4: 3.8 → 5: 3.9 ↓ 6: 7.5 ↗ 7: 0.0 → 8: 0.0 → 9: 0.0 ↓ 10: 8.5 ↖	40 Shots 	11: 0.0 ↓ 12: 0.0 ↓ 13: 3.4 ↗ 14: 0.0 ↓ 15: 0.0 → 16: 0.0 ↓ 17: 0.0 ↓ 18: 0.0 ↓ 19: 1.5 ↓ 20: 5.4 →
Series 32.0		Series 9.0	
Total 32.0		Total 41.0	

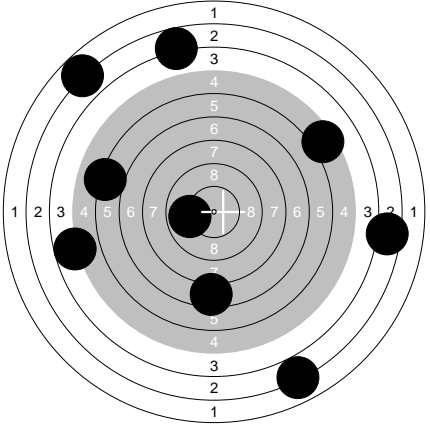
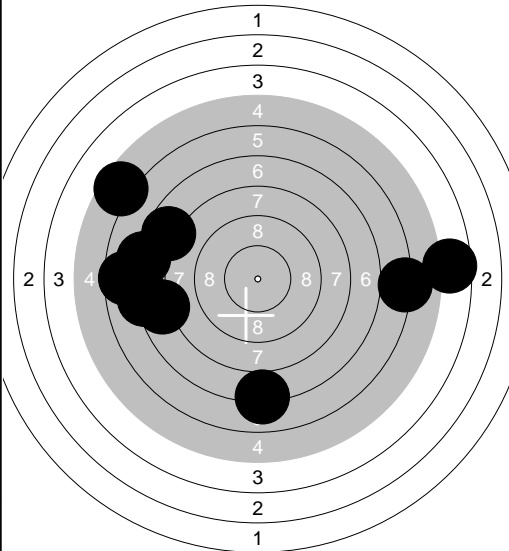
40 Shots 	21: 0.0 → 22: 7.4 ↓ 23: 5.4 ↗ 24: 2.8 ↗ 25: 3.4 → 26: 4.7 ↖ 27: 2.9 ↓ 28: 3.7 ↗ 29: 9.9 ↖ 30: 6.0 ↖	40 Shots 	31: 7.6 ↖ 32: 6.6 ↖ 33: 5.5 ↗ 34: 0.0 ↓ 35: 6.1 → 36: 7.6 ↖ 37: 7.1 ↖ 38: 4.6 → 39: 7.0 ↓ 40: 7.1 ↖
Series 41.0		Series 56.0	
Total 82.0		Total 138.0	

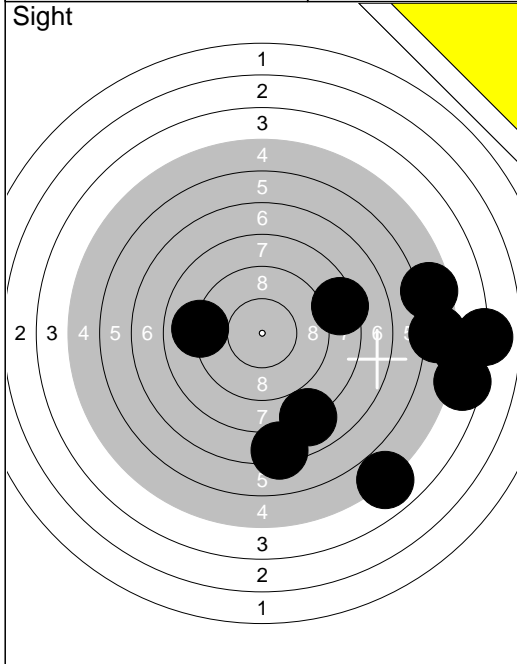

1:	4.0	→
2:	5.5	→
3:	4.7	→
4:	7.9	↙
5:	5.5	→
6:	5.0	↙
7:	4.5	→
8:	9.0	←
9:	8.4	→
10:	7.2	↓
Series		58.0
Total		0.0

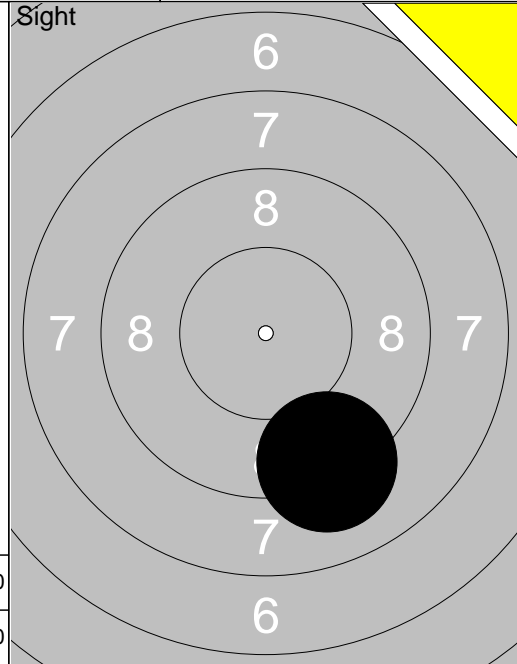

11:	9.1	↘
Series		9.0
Total		0.0

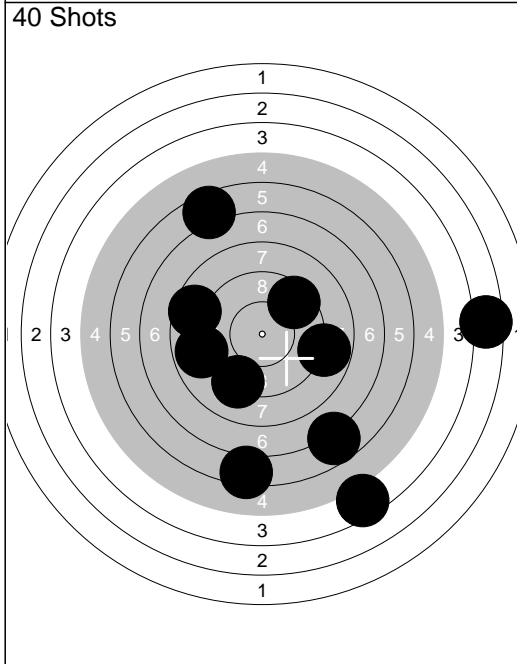

1:	9.2	↙
2:	4.4	↙
3:	9.5	↗
4:	6.5	↗
5:	6.3	↓
6:	8.6	←
7:	6.7	↙
8:	8.8	←
9:	3.4	→
10:	8.8	→
Series		67.0
Total		67.0

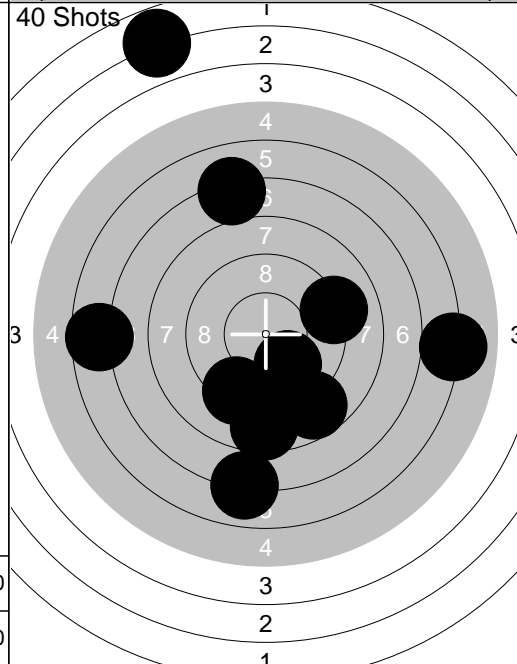

11:	6.9	↓
12:	6.0	→
13:	8.7	↙
14:	9.3	↙
15:	6.6	←
16:	10.0	↙
17:	9.1	↗
18:	7.1	↑
19:	2.8	↑
20:	8.5	↓
Series		71.0
Total		138.0

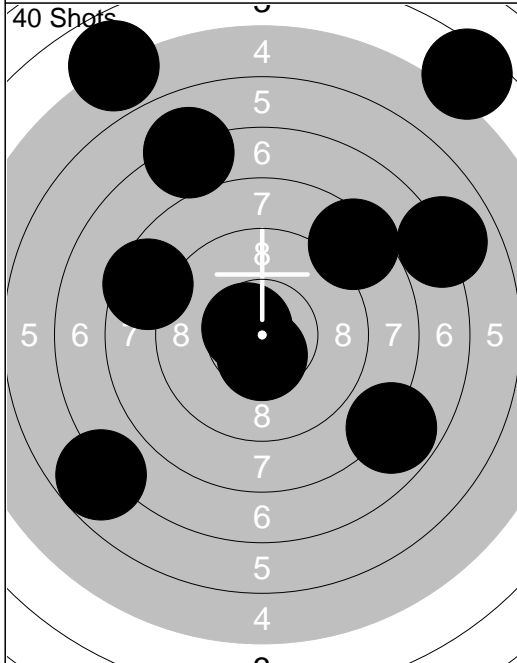

21:	*10.6	↓
22:	8.5	←
23:	8.4	↗
24:	7.8	↙
25:	6.7	↙
26:	4.4	↗
27:	*10.6	←
28:	4.9	↗
29:	7.0	↗
30:	7.1	↗
Series		71.0
Total		209.0

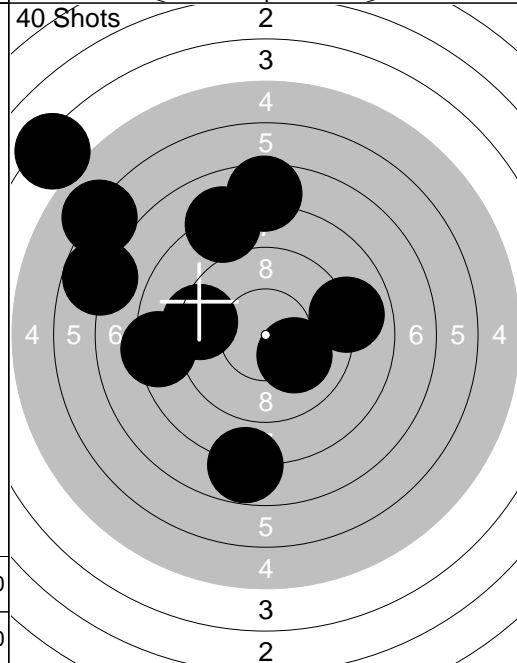

31:	6.8	←
32:	4.2	↗
33:	6.1	↗
34:	10.1	↙
35:	9.3	←
36:	7.6	↑
37:	8.9	→
38:	8.3	←
39:	8.1	↗
40:	7.8	↓
Series		73.0
Total		282.0

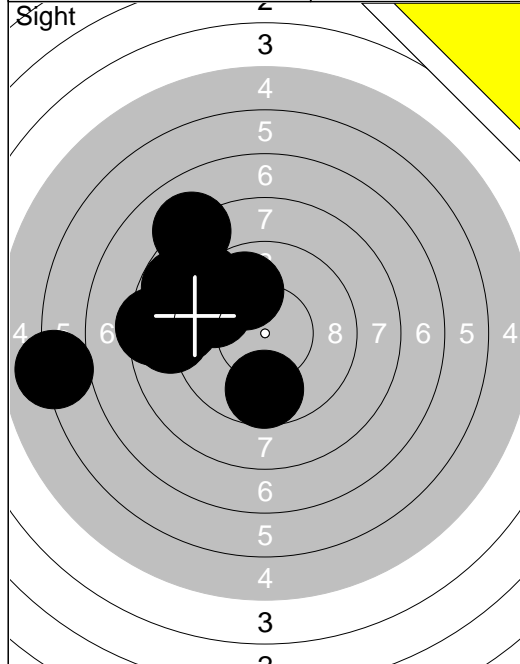

1:	6.1	←
2:	8.4	←
3:	8.8	↗
4:	9.6	↖
5:	9.7	↓
6:	9.0	←
7:	9.1	↗
8:	8.8	←
9:	8.1	↗
10:	9.9	↖
Series		83.0
Total		0.0

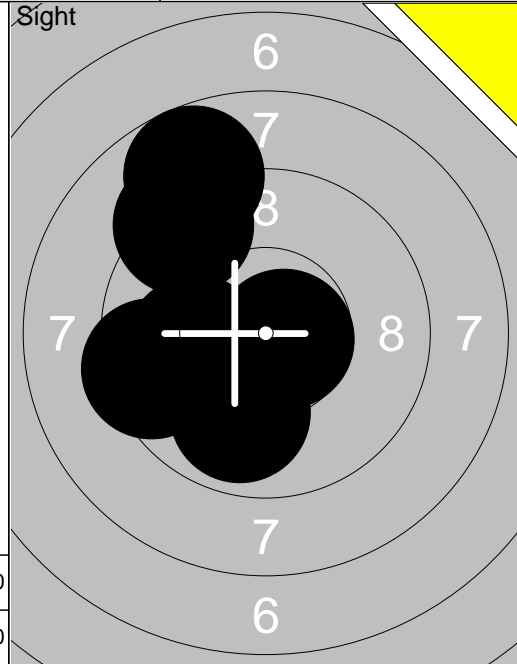

11:	9.2	↖
12:	8.7	↖
13:	9.9	↓
14:	9.4	←
15:	10.0	←
16:	*10.7	→
Series		55.0
Total		0.0

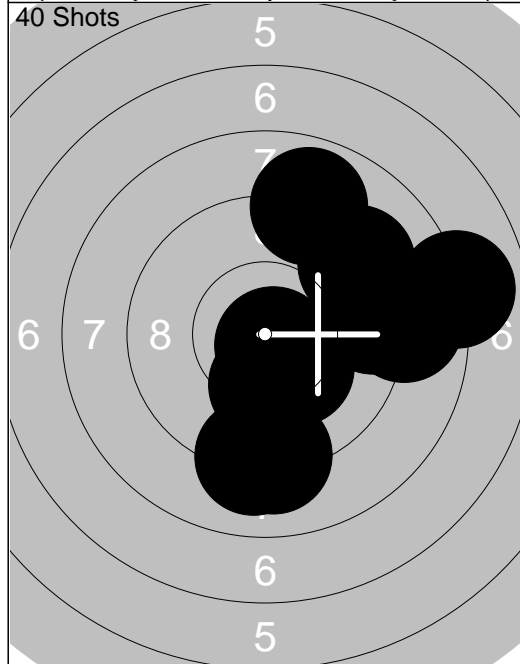

1:	9.2	↖
2:	9.3	→
3:	8.9	↖
4:	9.1	↓
5:	*10.3	↓
6:	8.8	→
7:	8.0	→
8:	9.1	↓
9:	*10.7	↓
10:	*10.2	↓
Series		90.0
Total		90.0

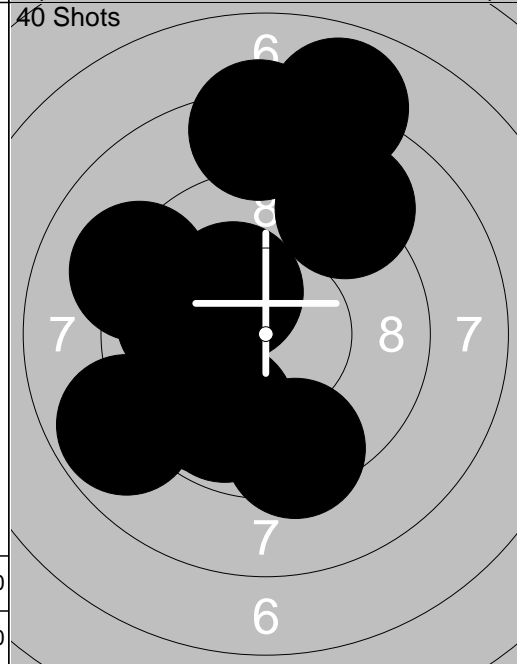

11:	9.8	↓
12:	9.8	↙
13:	*10.3	↖
14:	7.9	↖
15:	8.3	↖
16:	9.4	↓
17:	9.9	←
18:	9.1	↖
19:	8.8	↙
20:	9.1	↙
Series		87.0
Total		177.0

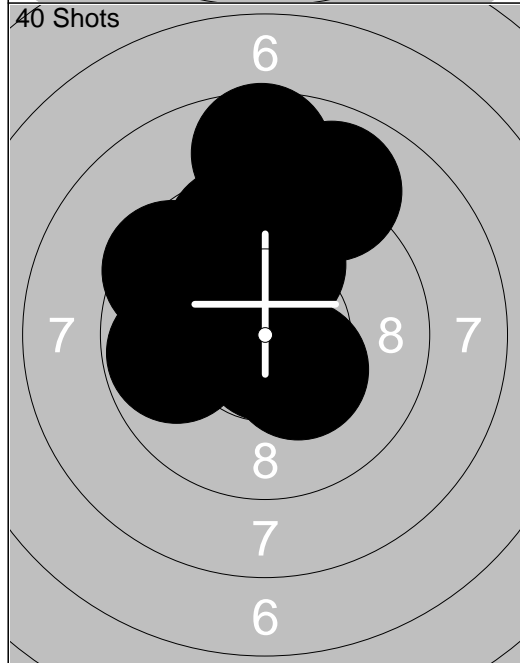

21:	*10.3	↓
22:	9.5	↖
23:	10.0	↖
24:	9.6	↖
25:	8.9	↖
26:	8.6	↖
27:	9.8	←
28:	*10.8	←
29:	*10.7	↓
30:	*10.7	↖
Series		93.0
Total		270.0

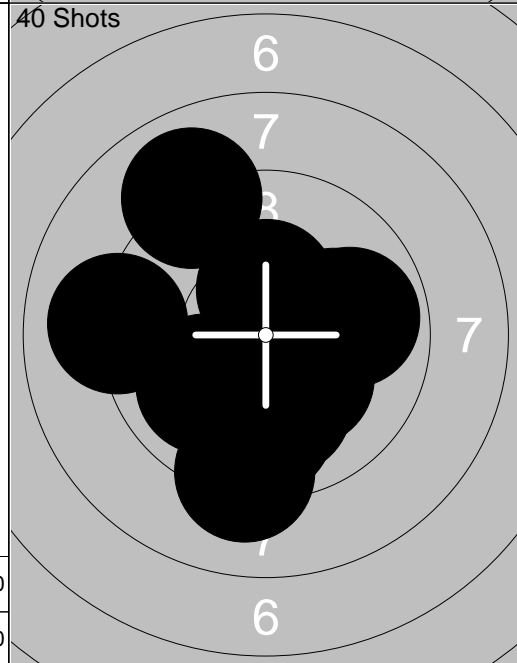

31:	9.8	↓
32:	9.2	↓
33:	10.0	↙
34:	10.1	→
35:	*10.4	↖
36:	9.9	→
37:	9.1	←
38:	9.0	↖
39:	*10.2	↓
40:	10.0	↓
Series		95.0
Total		365.0