

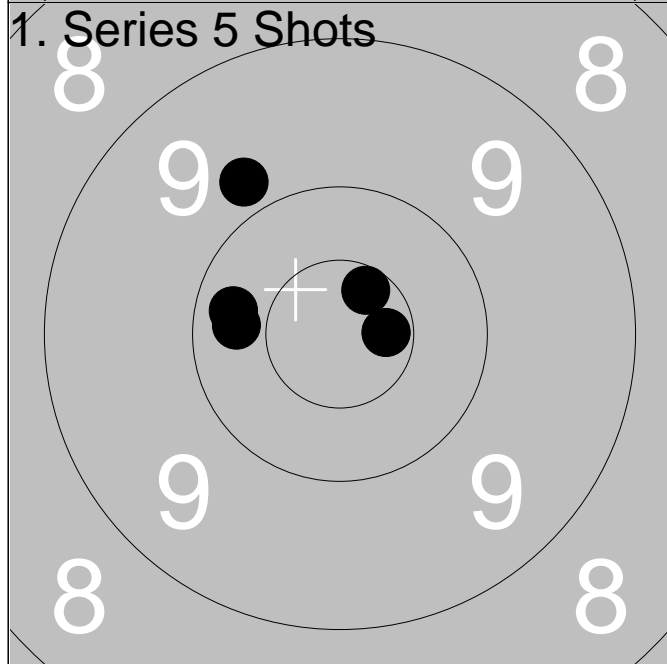

1:	10.2	↖
2:	*10.7	↙
3:	10.3	↘

Series	30.0
Total	242.0



1:	10.3	↖
2:	*10.7	→
3:	9.8	↗
4:	*10.6	↗
5:	10.3	↖

Series	49.0
Total	291.0

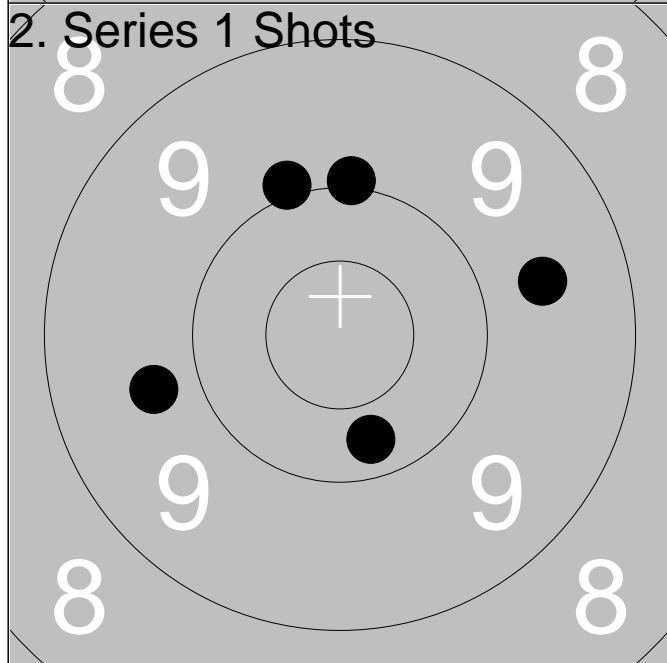

1:	10.0	↖
2:	9.7	↖
3:	9.6	→
4:	10.0	↗
5:	10.3	↘

Series	48.0
Total	339.0

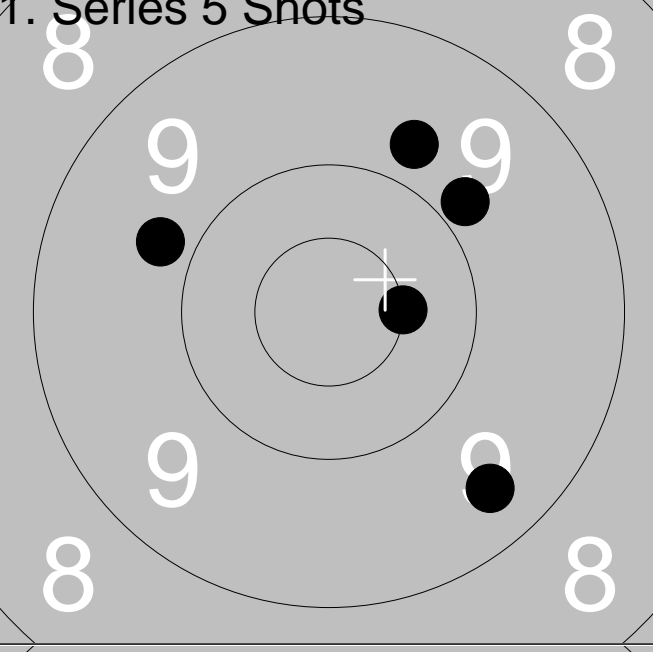
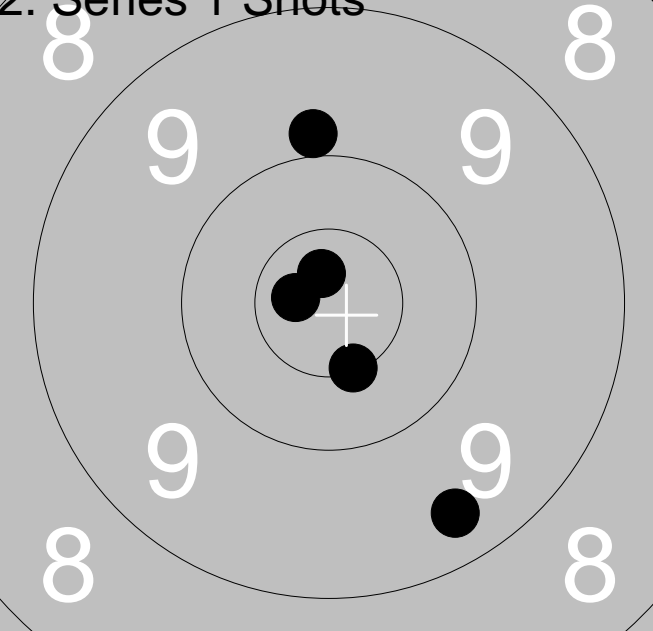
2013-07-06	Björskottet 2013	Ramselefors SKF
<b>5 Shots Sight</b> 	1:      *10.5	↖
	2:      9.1	↑
	3:      10.0	↙
	<b>Series</b>	<b>29.0</b>
<b>Total</b>		<b>240.0</b>
<b>1. Series 5 Shots</b> 	1:      9.8	↖
	2:      *10.5	→
	3:      9.8	↗
	4:      9.4	↘
	5:      9.8	↗
	<b>Series</b>	<b>46.0</b>
<b>Total</b>		<b>286.0</b>
<b>2. Series 1 Shots</b> 	1:      *10.8	↖
	2:      *10.5	↘
	3:      9.9	↑
	4:      9.4	↘
	5:      *10.7	↙
	<b>Series</b>	<b>48.0</b>
<b>Total</b>		<b>334.0</b>

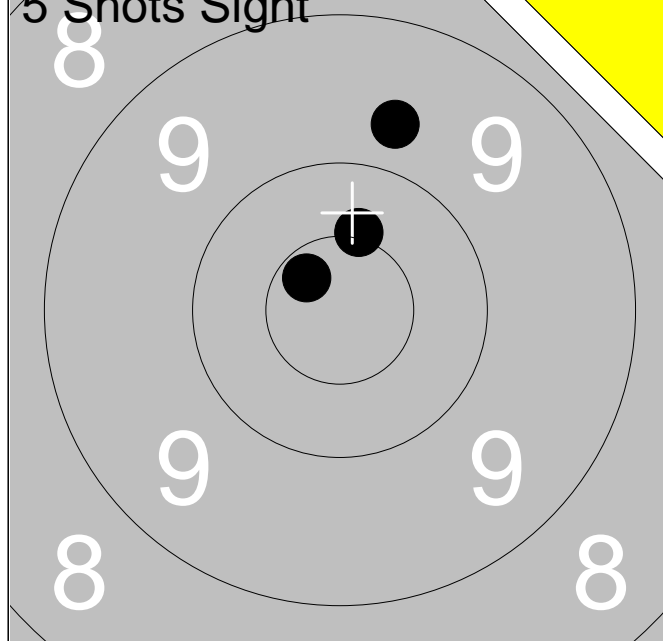

	1:	*10.4	↑
	2:	9.7	↑
	3:	*10.7	↖
<b>Series</b>			<b>29.0</b>
<b>Total</b>			<b>238.0</b>

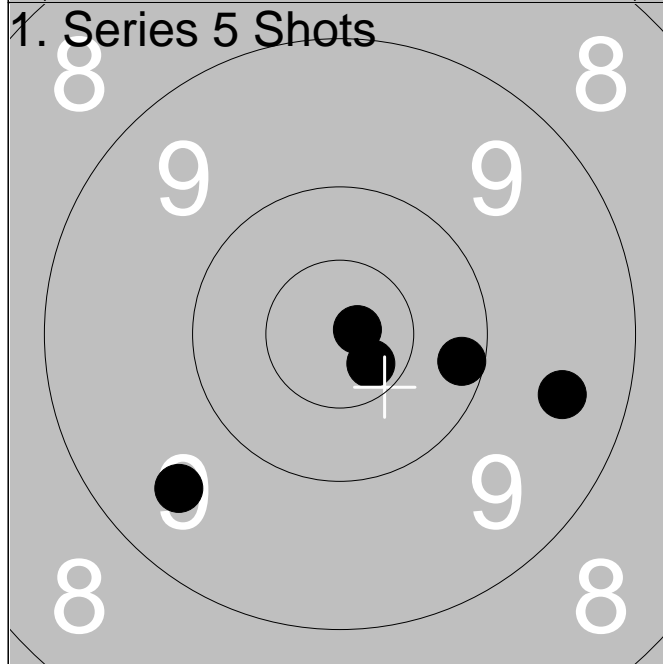

	1:	*10.7	↘
	2:	*10.8	→
	3:	10.2	→
	4:	9.5	→
	5:	9.5	↙
<b>Series</b>			<b>48.0</b>
<b>Total</b>			<b>286.0</b>

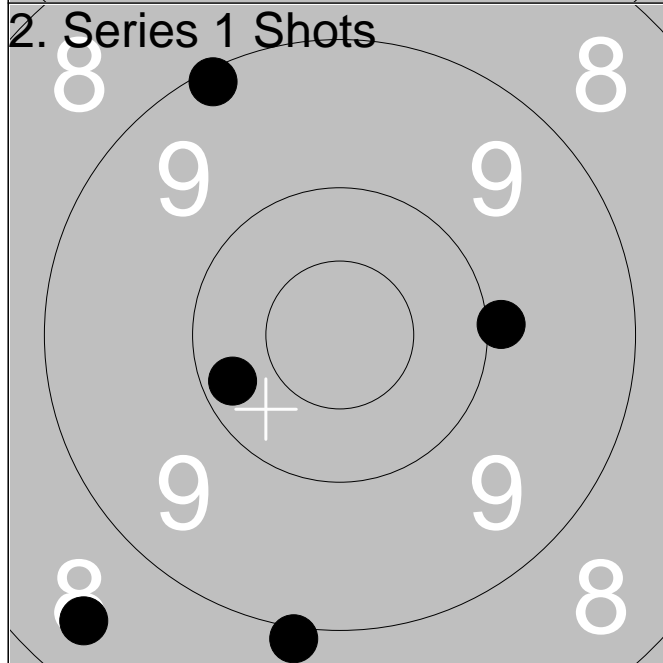

	1:	8.9	↓
	2:	9.1	↑
	3:	10.2	←
	4:	9.9	→
	5:	8.4	↙
<b>Series</b>			<b>44.0</b>
<b>Total</b>			<b>330.0</b>

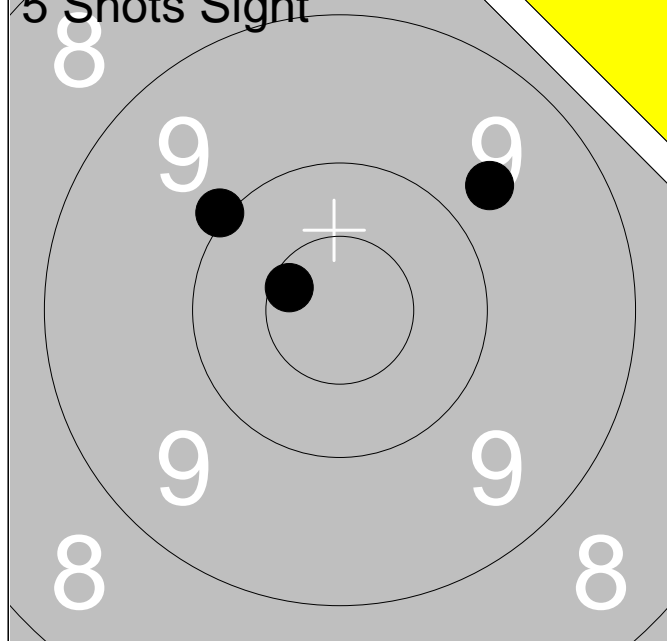

	1:	10.0	↗
	2:	9.7	↗
	3:	*10.6	↗
<b>Series</b>			<b>29.0</b>
<b>Total</b>			<b>234.0</b>

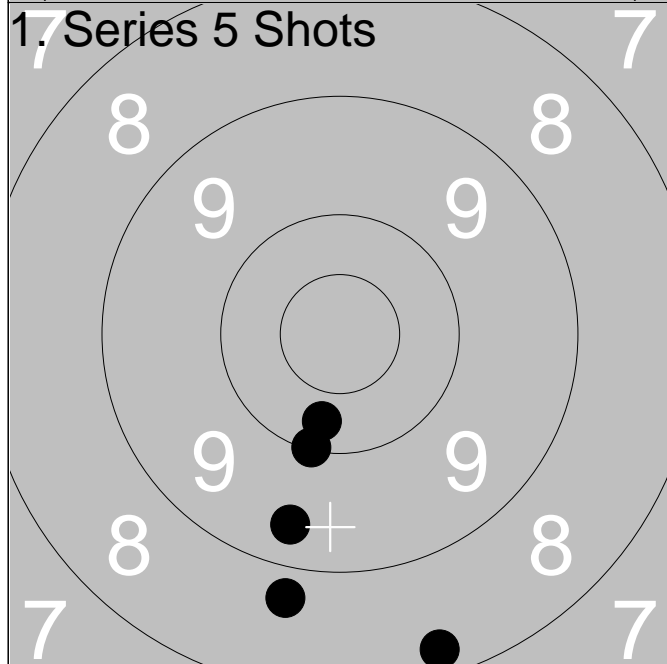

	1:	9.4	↓
	2:	8.3	↓
	3:	10.0	↓
	4:	8.8	↓
	5:	10.3	↓
<b>Series</b>			<b>45.0</b>
<b>Total</b>			<b>279.0</b>

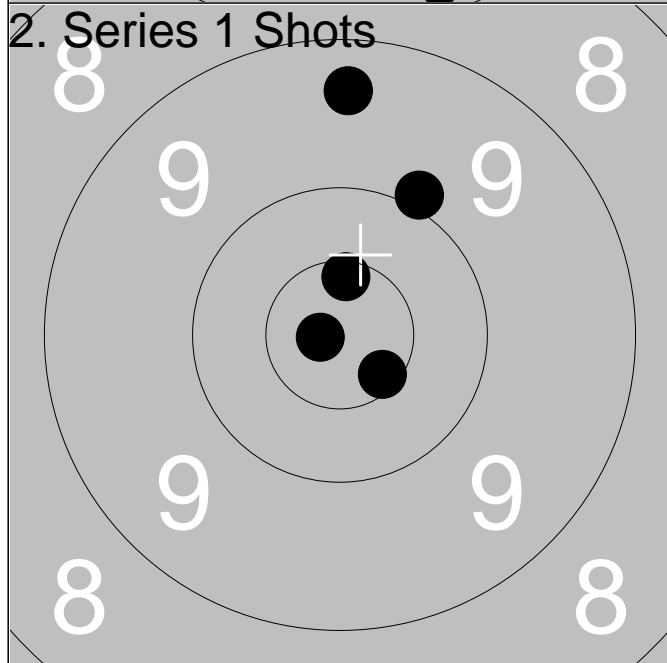

	1:	*10.6	↘
	2:	9.9	↗
	3:	9.4	↑
	4:	*10.8	←
	5:	*10.6	↑
<b>Series</b>			<b>48.0</b>
<b>Total</b>			<b>327.0</b>

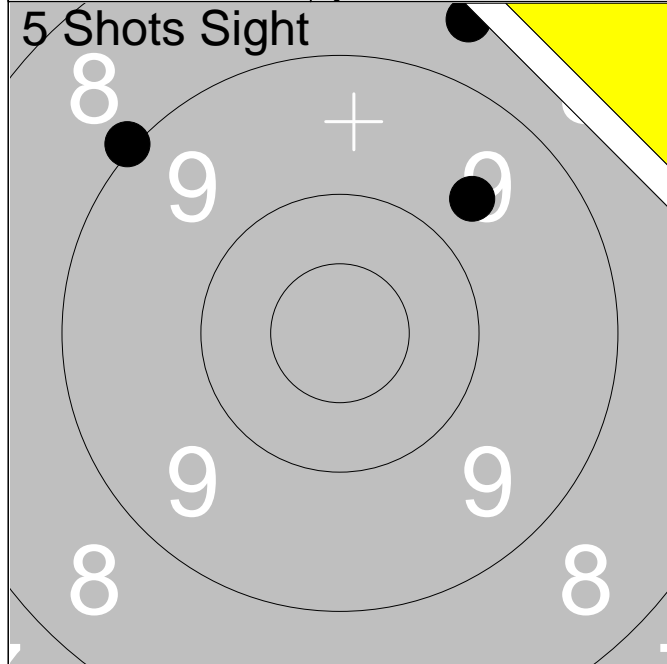

1:	9.0	↖
2:	9.7	↗
3:	8.6	↗
<b>Series</b>	<b>26.0</b>	
<b>Total</b>	<b>231.0</b>	

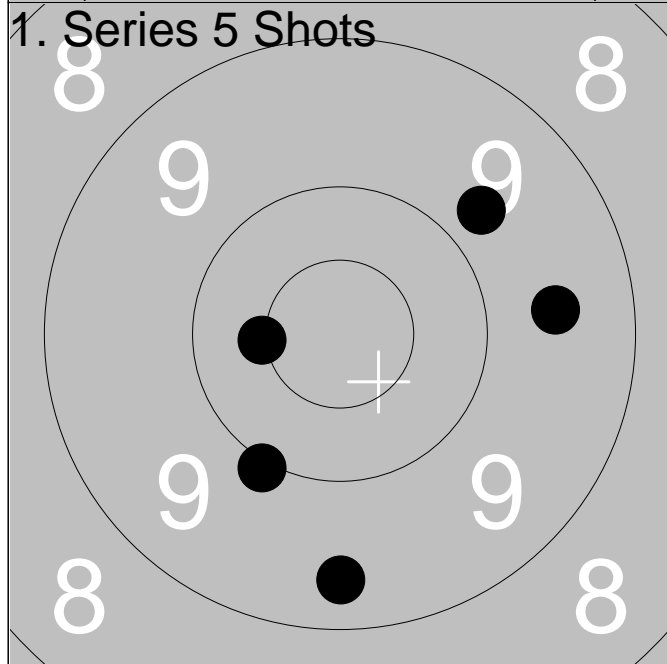

1:	9.4	↓
2:	10.0	↙
3:	9.6	→
4:	*10.5	←
5:	9.8	↗
<b>Series</b>	<b>47.0</b>	
<b>Total</b>	<b>278.0</b>	

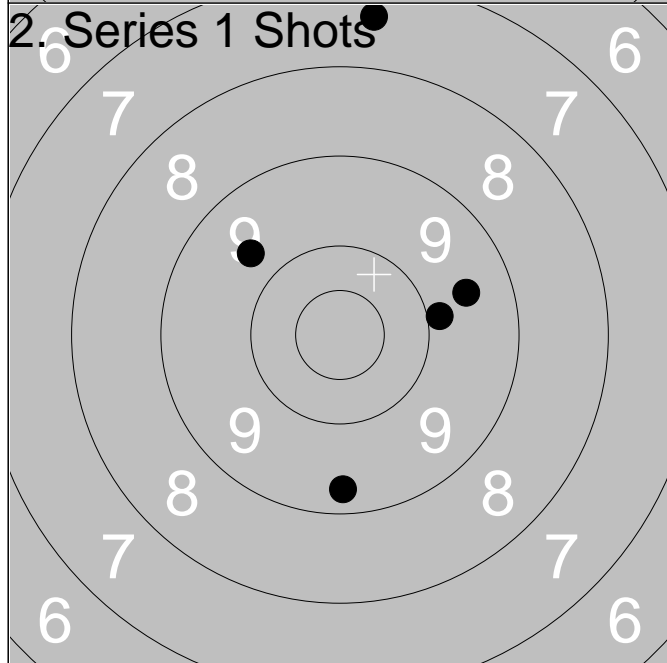

1:	9.3	↓
2:	7.5	↑
3:	9.5	→
4:	9.9	→
5:	9.7	↖
<b>Series</b>	<b>43.0</b>	
<b>Total</b>	<b>321.0</b>	



1:	9.5	↗
2:	9.2	↖
3:	10.2	→
Series		28.0
Total		225.0

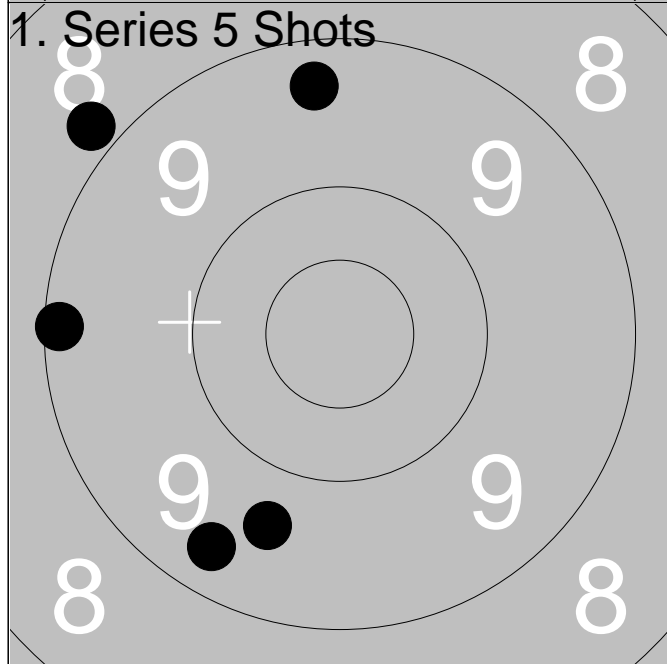

1:	8.8	↗
2:	9.1	↖
3:	9.3	↑
4:	9.4	↙
5:	9.6	↘
Series		44.0
Total		269.0

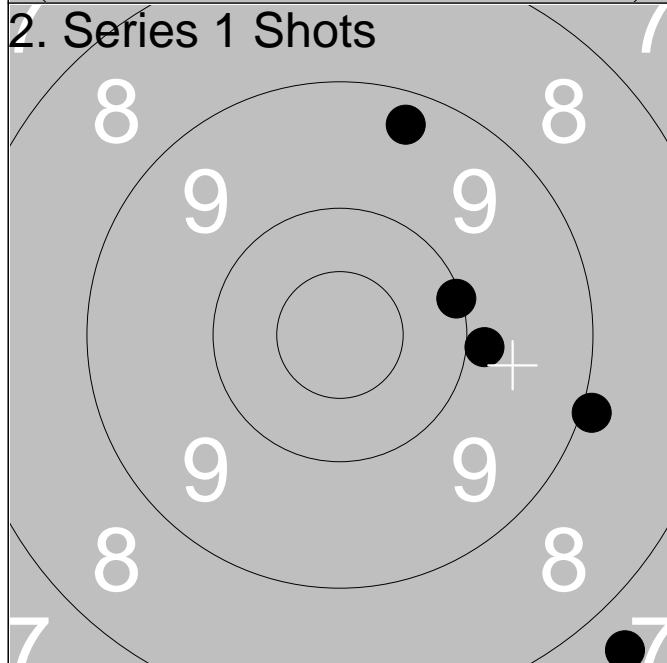

1:	9.3	↑
2:	10.1	→
3:	9.9	→
4:	8.9	→
5:	7.7	↘
Series		43.0
Total		312.0

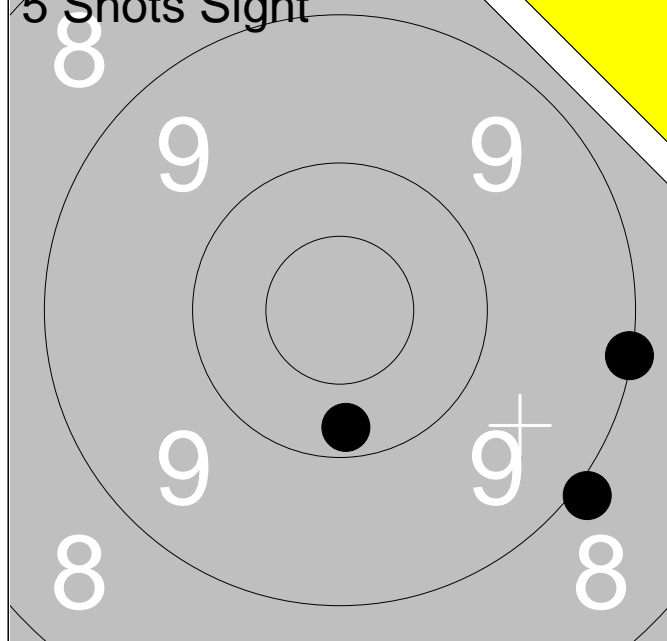

	1:	10.2		↓
	2:	9.0		→
	3:	8.9		↘
<hr/>				
Series				27.0
Total				208.0

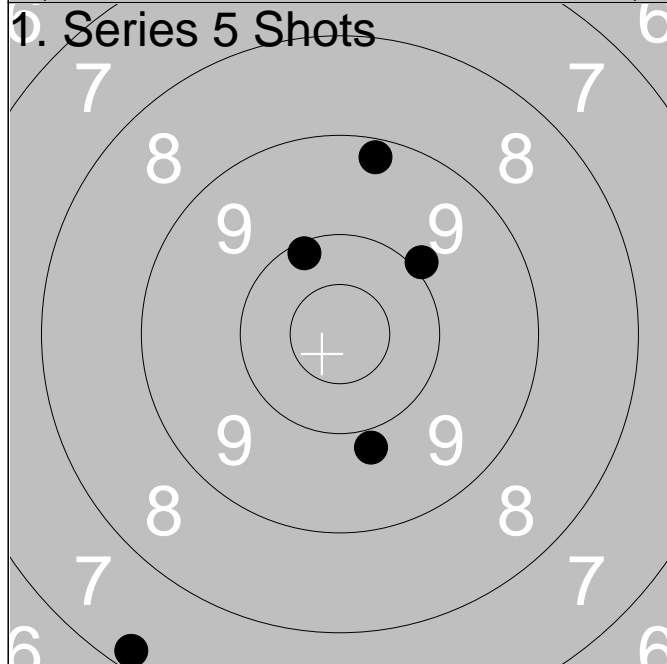

	1:	9.8		↓
	2:	9.9		↗
	3:	10.1		↖
	4:	7.2		↙
	5:	9.2		↑
<hr/>				
Series				44.0
Total				252.0

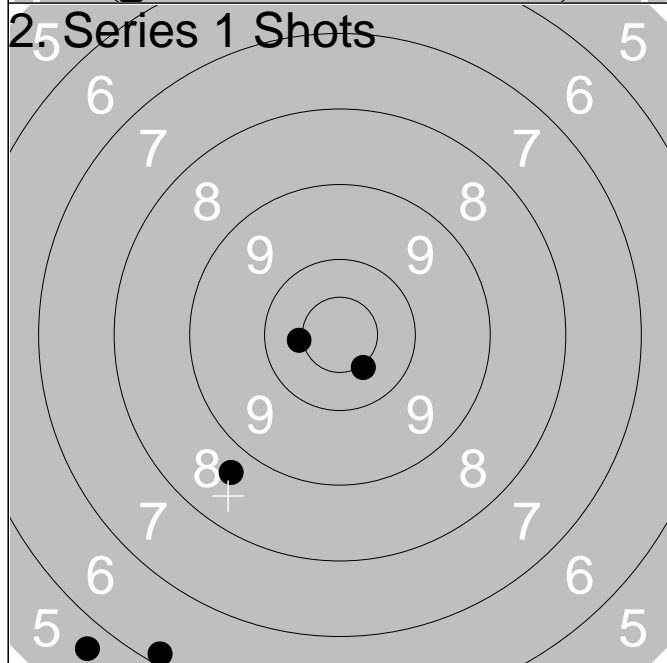

	1:	8.7		↙
	2:	5.7		↙
	3:	*10.5		↘
	4:	6.2		↙
	5:	*10.4		←
<hr/>				
Series				39.0
Total				291.0



1:	7.5	↙
2:	10.1	↑
3:	9.6	↘
<b>Series</b>	<b>26.0</b>	
<b>Total</b>	<b>198.0</b>	

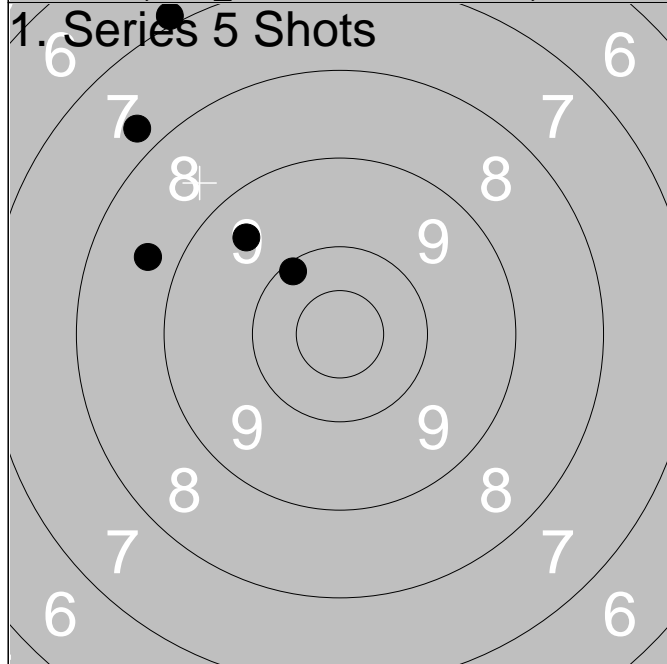

1:	7.8	↗
2:	9.5	↗
3:	6.9	↗
4:	8.7	↗
5:	10.1	↗
<b>Series</b>	<b>40.0</b>	
<b>Total</b>	<b>238.0</b>	

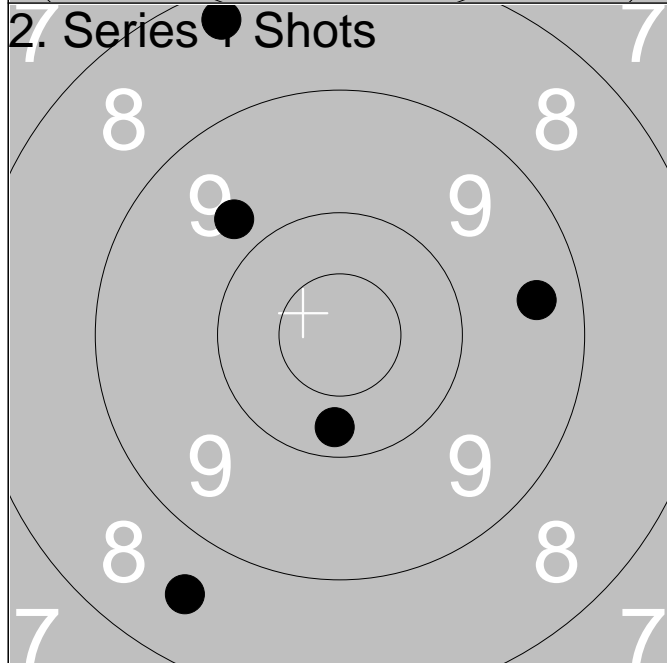

1:	8.6	↙
2:	9.8	↗
3:	8.3	↗
4:	9.4	→
5:	10.3	↘
<b>Series</b>	<b>44.0</b>	
<b>Total</b>	<b>282.0</b>	





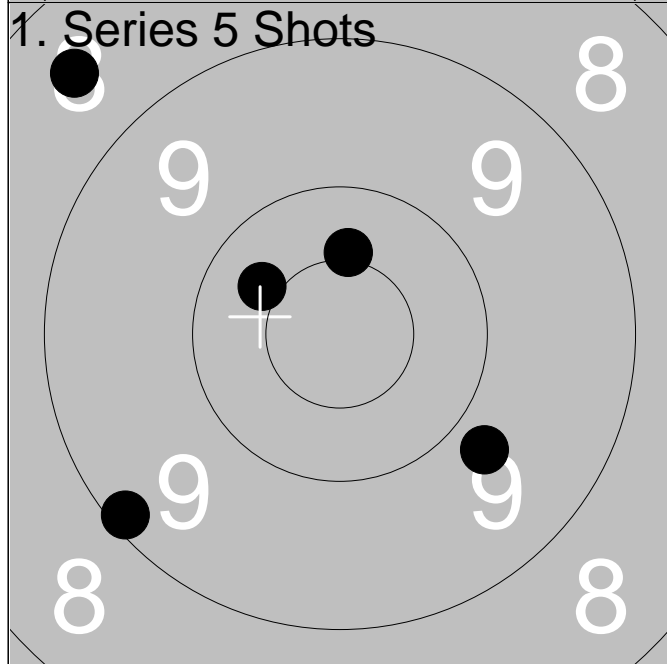

	1:	9.1	→
	2:	9.5	↓
	3:	10.0	→
<b>Series</b>			<b>28.0</b>
<b>Total</b>			<b>182.0</b>

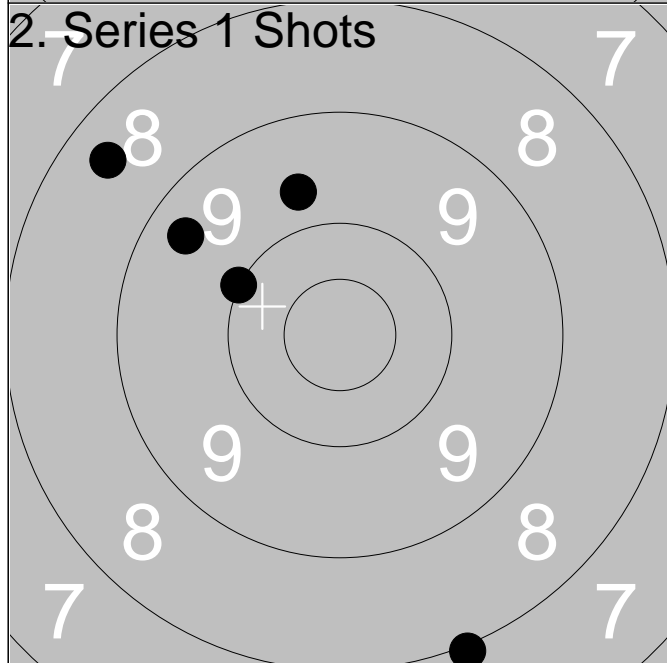

	1:	9.8	↘
	2:	8.5	↗
	3:	9.1	↙
	4:	*10.4	↑
	5:	10.4	↗
<b>Series</b>			<b>46.0</b>
<b>Total</b>			<b>228.0</b>

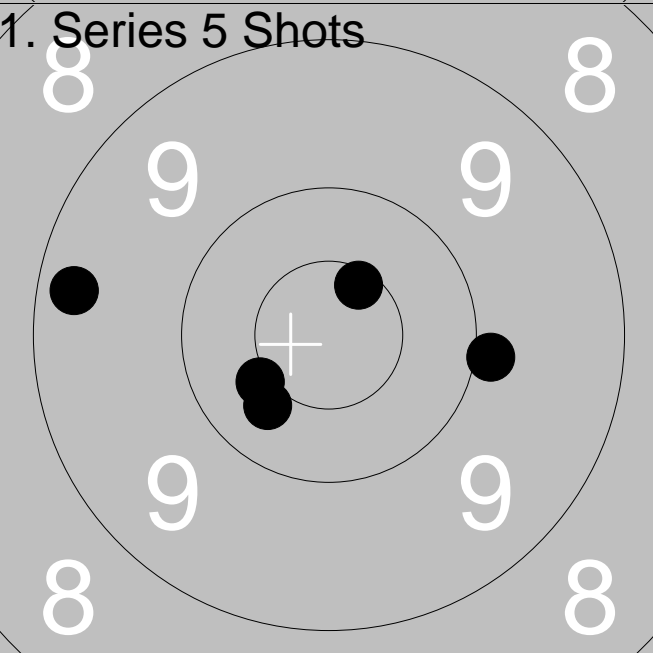
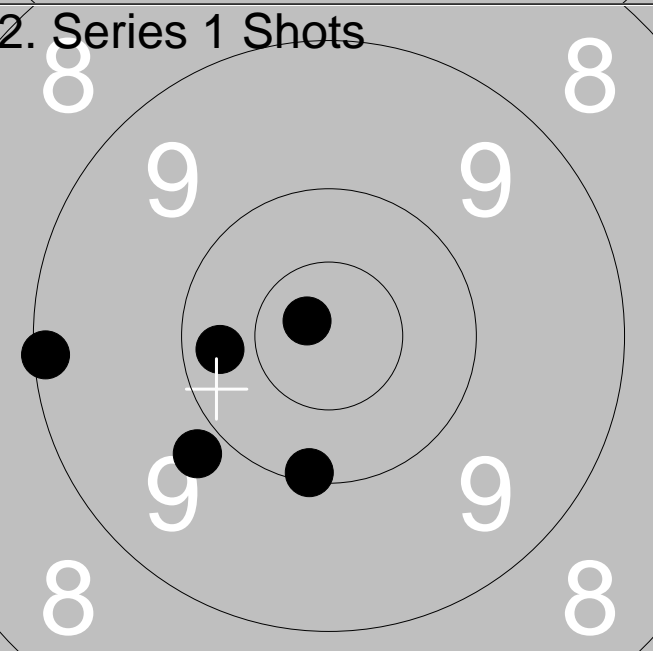

	1:	9.7	↑
	2:	10.0	↗
	3:	9.4	↗
	4:	8.0	↘
	5:	8.4	↗
<b>Series</b>			<b>44.0</b>
<b>Total</b>			<b>272.0</b>

Relay <b>4</b>	Lane <b>12</b>	<b>Håkan Lidman</b>		
300m		Skellefteå	LiggE	Vb
2013-07-06		Björkskottet 2013	Ramselefors SKF	
<b>5 Shots Sight</b>				
		1: *10.4		→
		2: 9.8		↘
		3: 9.9		←
		<b>Series 28.0</b>		
		<b>Total 238.0</b>		
<b>1. Series 5 Shots</b>				
		1: 10.4		↙
		2: 9.9		→
		3: *10.6		↗
		4: 9.3		←
		5: *10.4		↙
		<b>Series 48.0</b>		
		<b>Total 286.0</b>		
<b>2. Series 1 Shots</b>				
		1: 10.1		↓
		2: 9.8		↙
		3: 9.1		←
		4: *10.8		↗
		5: 10.3		←
		<b>Series 48.0</b>		
		<b>Total 334.0</b>		

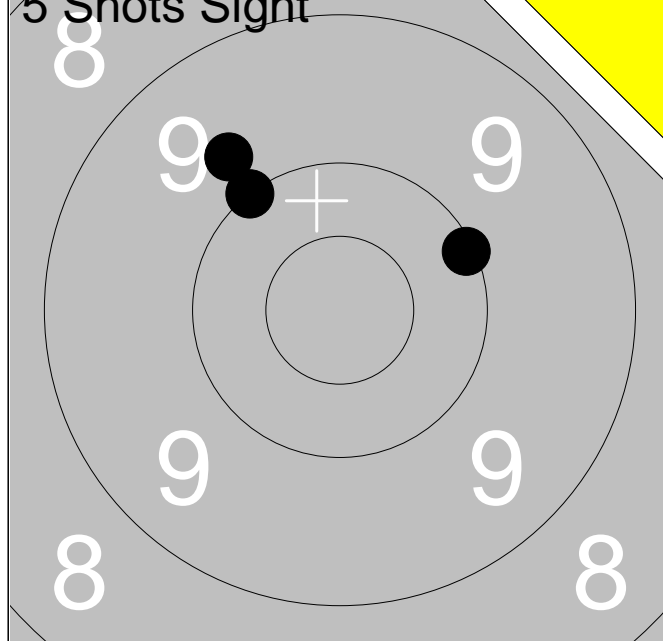

1:	9.7	↖
2:	10.1	↗
3:	10.0	↖

Series	29.0
Total	235.0

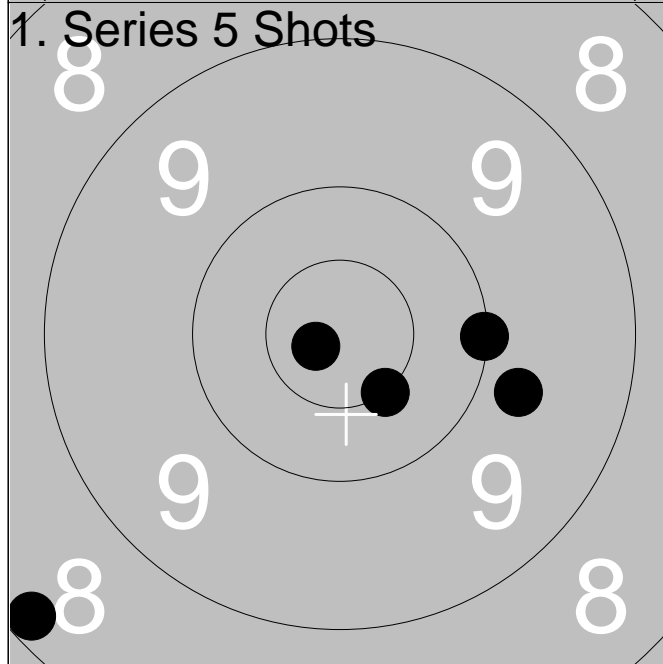

1:	8.2	↙
2:	9.8	↘
3:	10.0	→
4:	*10.8	↙
5:	*10.5	↘

Series	47.0
Total	282.0

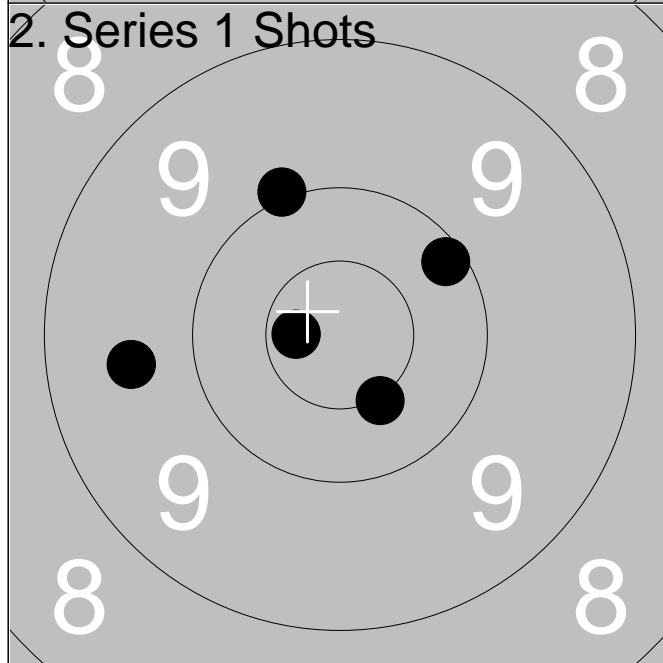

1:	10.0	↖
2:	10.1	↗
3:	9.6	↙
4:	*10.5	↘
5:	*10.7	↙

Series	49.0
Total	331.0



1:	9.9	→
2:	9.6	↘
3:	10.4	↘
<b>Series</b>		<b>28.0</b>
<b>Total</b>		<b>234.0</b>

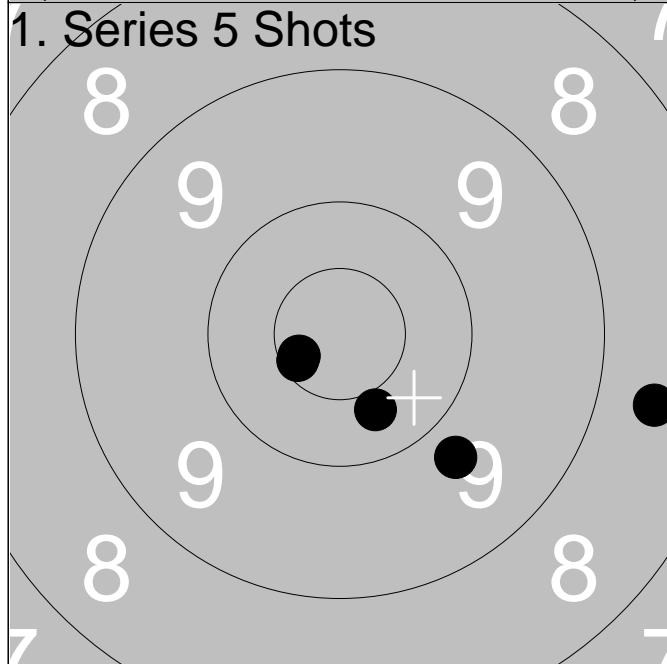

1:	9.8	↘
2:	8.6	→
3:	10.4	↘
4:	*10.6	↙
5:	*10.6	↙
<b>Series</b>		<b>47.0</b>
<b>Total</b>		<b>281.0</b>

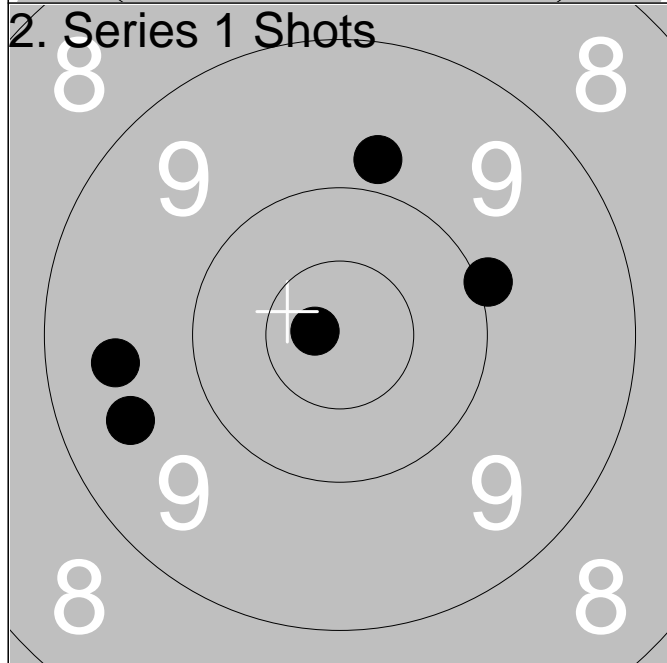

1:	10.0	→
2:	9.8	↑
3:	*10.8	←
4:	9.5	←
5:	9.5	↙
<b>Series</b>		<b>47.0</b>
<b>Total</b>		<b>328.0</b>

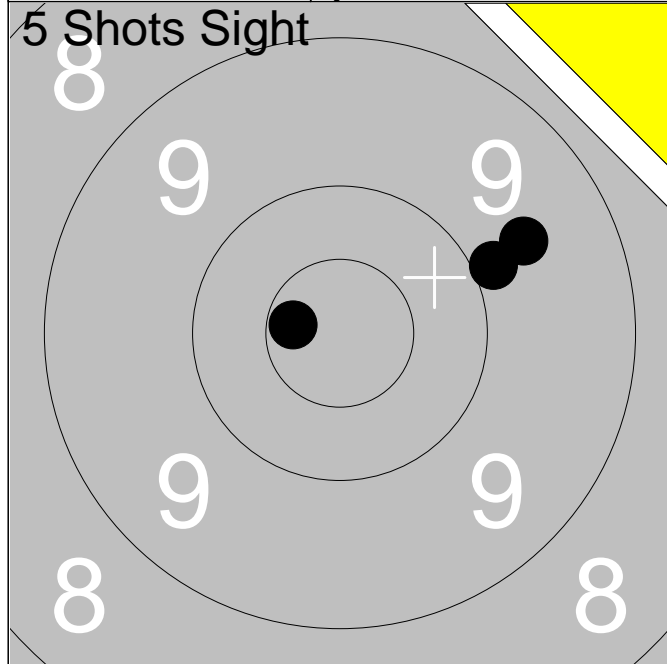

1:	9.9	→
2:	*10.7	←
3:	9.6	→

Series	28.0
Total	225.0

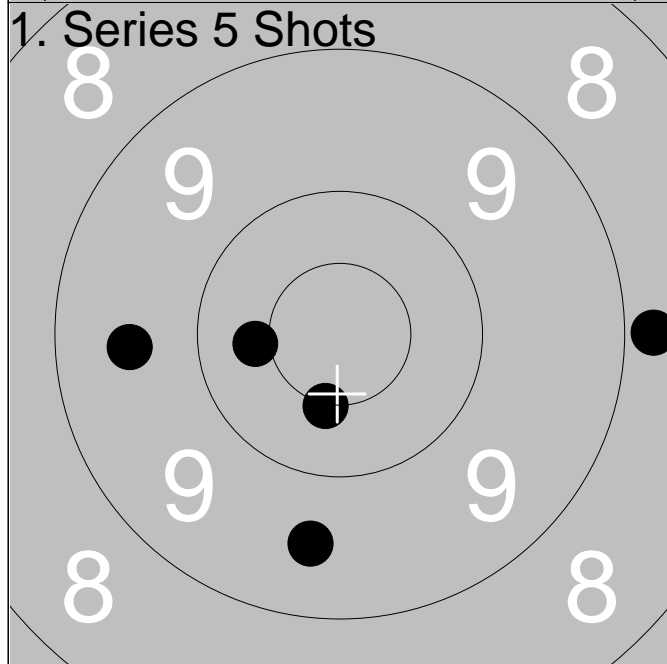

1:	*10.5	↓
2:	8.8	→
3:	9.5	↓
4:	10.4	←
5:	9.6	←

Series	46.0
Total	271.0

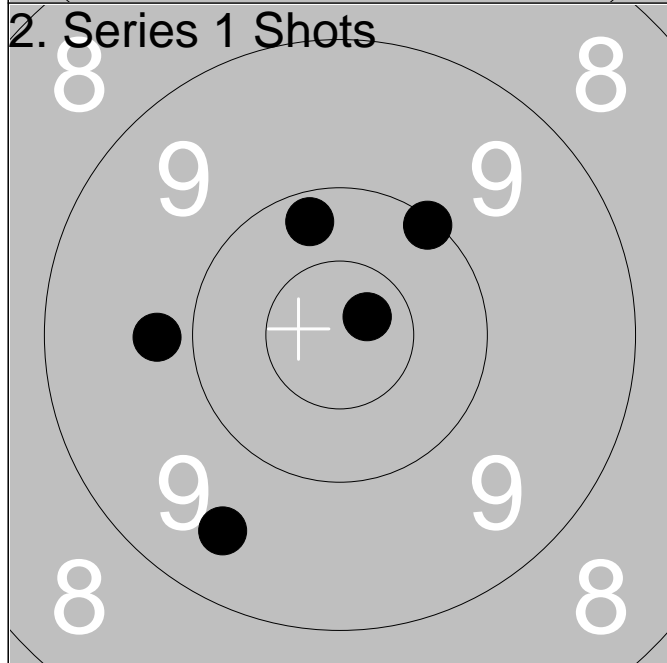

1:	9.5	↙
2:	9.8	←
3:	10.2	↑
4:	10.1	↗
5:	*10.7	→

Series	48.0
Total	319.0



1:	9.0	→
2:	9.8	↑
3:	*10.9	←
<b>Series</b>		<b>28.0</b>
<b>Total</b>		<b>219.0</b>

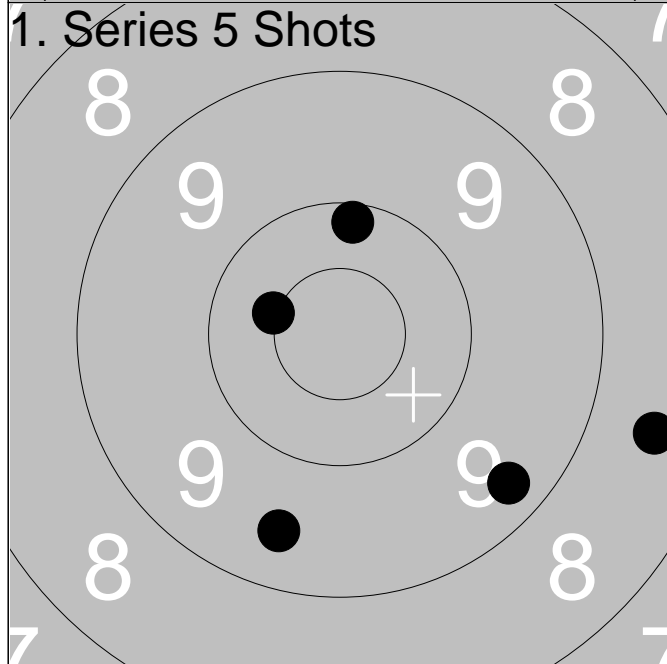

1:	8.5	→
2:	10.2	↑
3:	*10.5	←
4:	9.3	↘
5:	9.5	↙
<b>Series</b>		<b>46.0</b>
<b>Total</b>		<b>265.0</b>

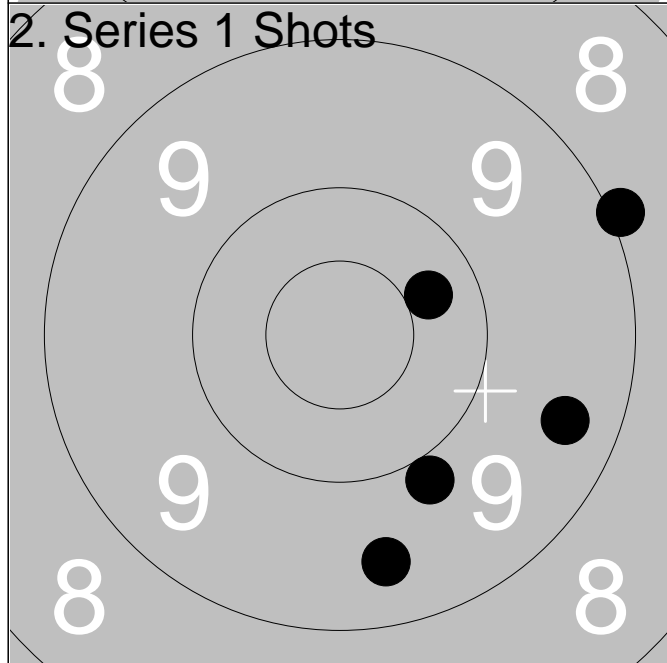

1:	9.0	↗
2:	9.9	↘
3:	10.3	↗
4:	9.5	↘
5:	9.4	→
<b>Series</b>		<b>46.0</b>
<b>Total</b>		<b>311.0</b>



	1:	8.3	←
	2:	8.3	↗
	3:	8.4	←
<b>Series</b>			<b>24.0</b>
<b>Total</b>			<b>228.0</b>

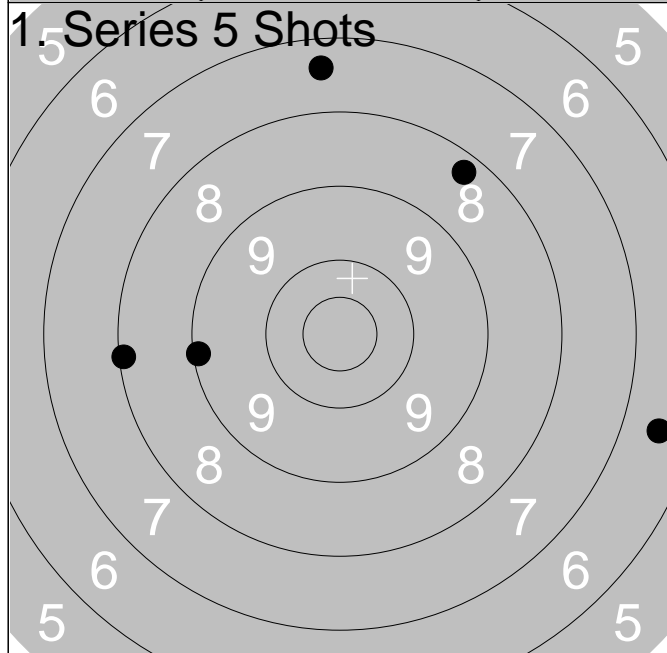

	1:	7.4	↑
	2:	8.3	↗
	3:	9.1	←
	4:	8.1	←
	5:	6.5	→
<b>Series</b>			<b>38.0</b>
<b>Total</b>			<b>266.0</b>

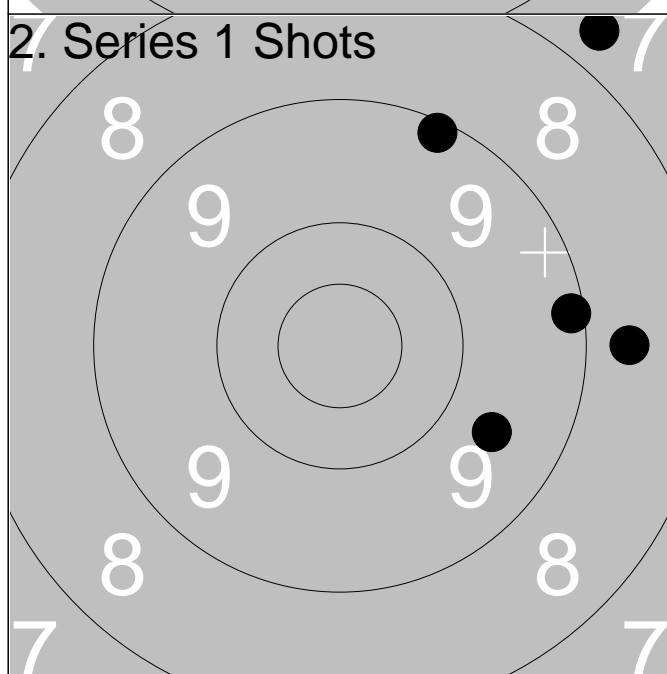

	1:	7.7	↗
	2:	9.6	↘
	3:	8.7	→
	4:	9.1	↗
	5:	9.1	→
<b>Series</b>			<b>42.0</b>
<b>Total</b>			<b>308.0</b>

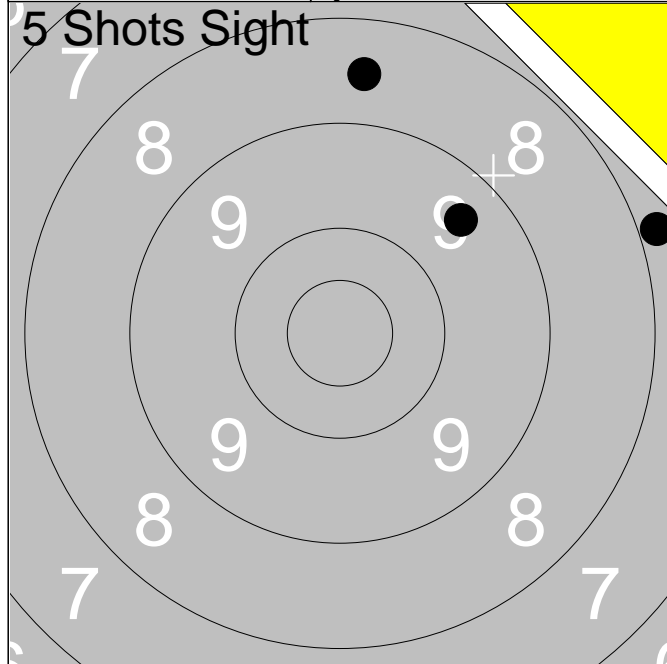

	1:	8.5	↑
	2:	7.9	→
	3:	9.4	↗
<b>Series</b>			<b>24.0</b>
<b>Total</b>			<b>227.0</b>

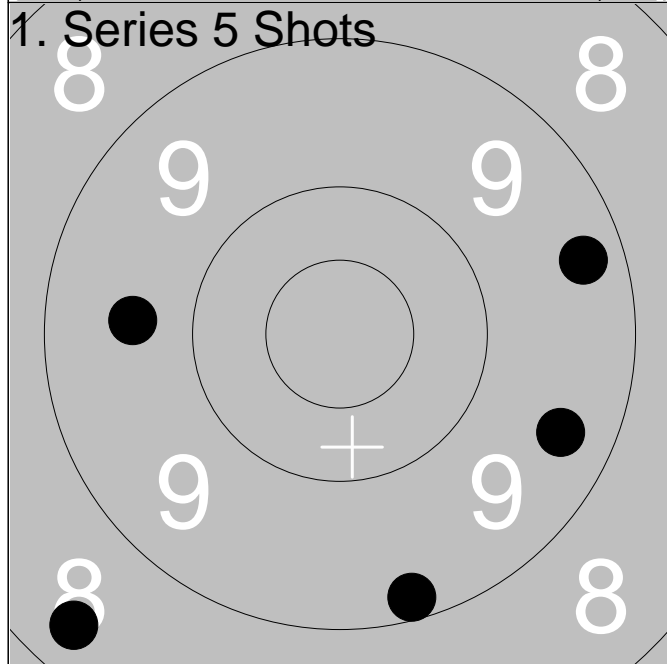

	1:	9.6	←
	2:	8.4	↙
	3:	9.3	→
	4:	9.4	↘
	5:	9.2	↓
<b>Series</b>			<b>44.0</b>
<b>Total</b>			<b>271.0</b>

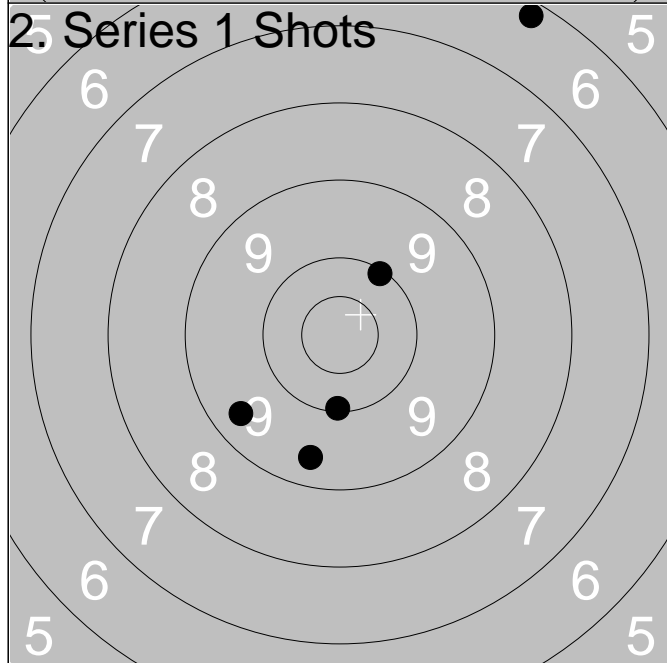

	1:	10.1	↓
	2:	9.4	↙
	3:	6.2	↗
	4:	10.1	↗
	5:	9.4	↓
<b>Series</b>			<b>44.0</b>
<b>Total</b>			<b>315.0</b>





1:	6.7	↙
2:	9.8	↗
3:	9.4	↓
<b>Series</b>		<b>24.0</b>
<b>Total</b>		<b>226.0</b>

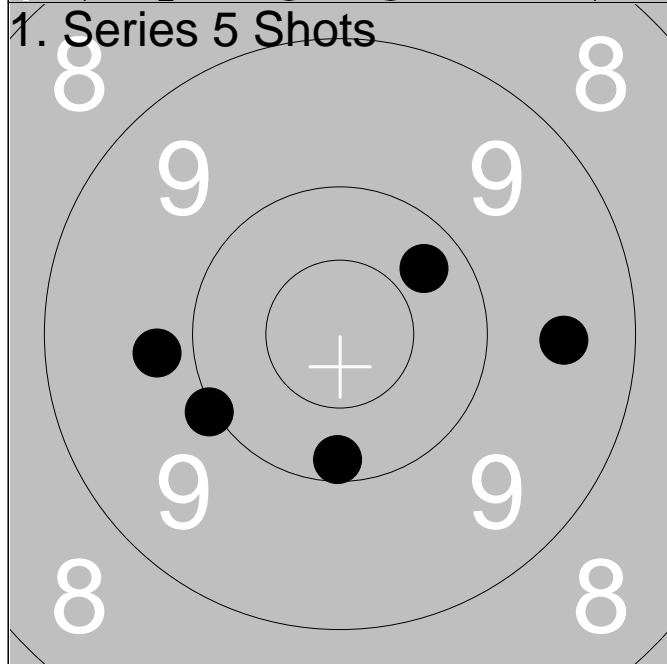

1:	10.3	↗
2:	9.5	→
3:	9.8	←
4:	10.0	↙
5:	10.2	↓
<b>Series</b>		<b>48.0</b>
<b>Total</b>		<b>274.0</b>

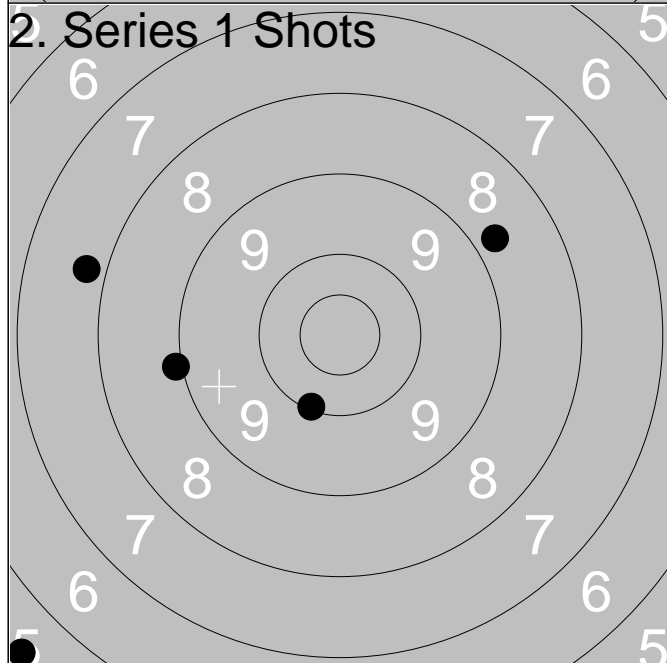

1:	9.0	←
2:	10.1	↓
3:	5.5	↙
4:	7.8	←
5:	8.8	↗
<b>Series</b>		<b>39.0</b>
<b>Total</b>		<b>313.0</b>

Relay <b>5</b>	Lane <b>4</b>	<b>Linda Bergman</b>
-------------------	------------------	----------------------

300m	Ununge	SenB	St
------	--------	------	----

2013-07-06	Björskottet 2013	Ramselefors SKF
------------	------------------	-----------------



1:	8.6	←
2:	*10.5	↙
3:	8.6	↑
Series		26.0
Total		225.0

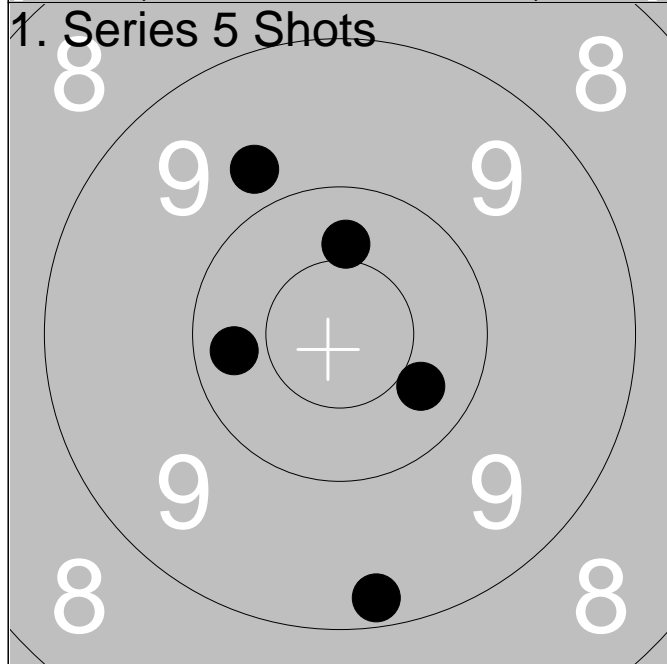

1:	10.3	↘
2:	9.8	↖
3:	10.3	←
4:	10.4	↑
5:	9.2	↓
Series		48.0
Total		273.0

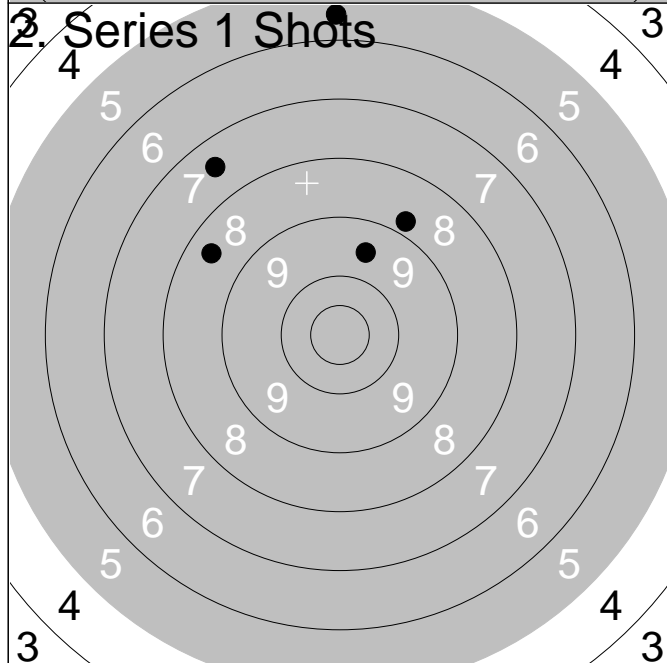

1:	8.8	↗
2:	9.6	↗
3:	7.5	↖
4:	5.6	↑
5:	8.4	↘
Series		37.0
Total		310.0

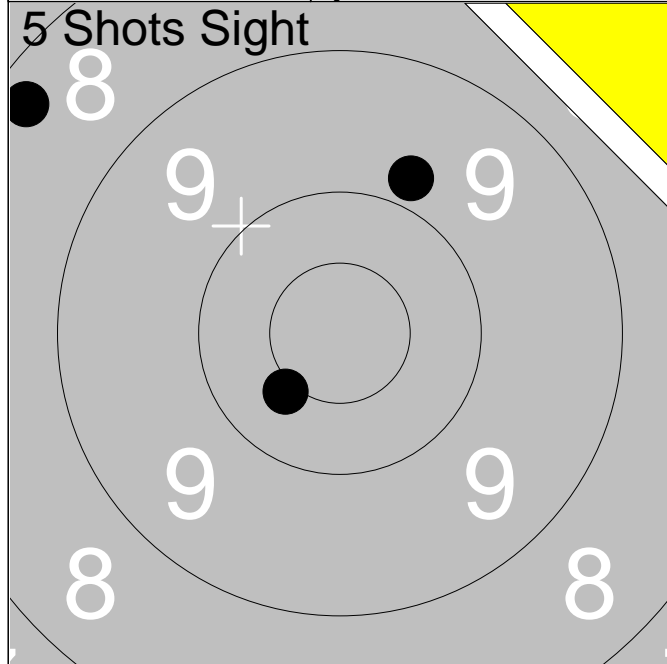

1:	8.3	↖
2:	*10.4	↙
3:	9.8	↗
<b>Series</b>		<b>27.0</b>
<b>Total</b>		<b>225.0</b>

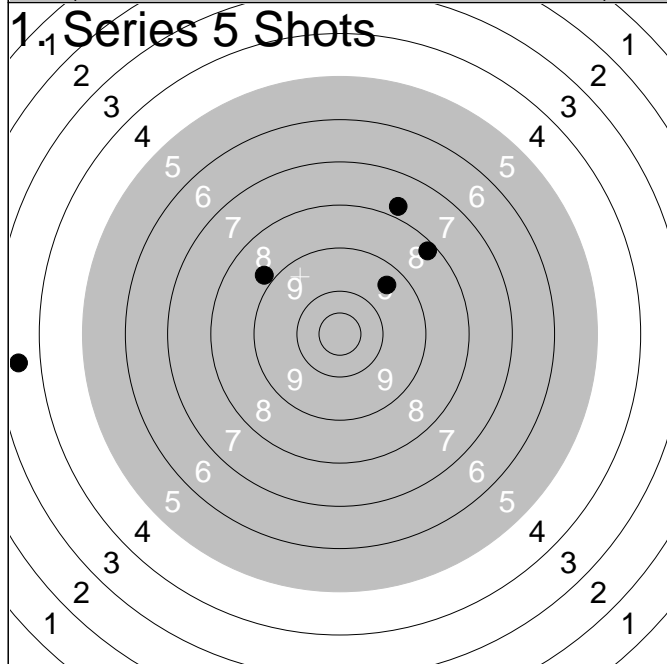

1:	7.8	↗
2:	9.4	↗
3:	8.8	↖
4:	8.2	↗
5:	3.5	←
<b>Series</b>		<b>35.0</b>
<b>Total</b>		<b>260.0</b>

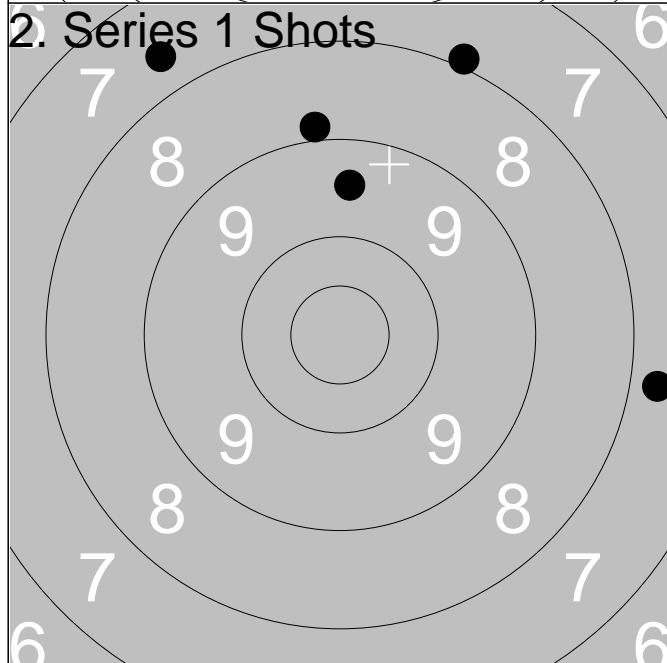

1:	7.7	↖
2:	8.9	↗
3:	7.8	→
4:	9.5	↗
5:	7.9	↗
<b>Series</b>		<b>38.0</b>
<b>Total</b>		<b>298.0</b>



	1:	7.8	←
	2:	9.3	↑
	3:	9.3	↑
<b>Series</b>			<b>25.0</b>
<b>Total</b>			<b>223.0</b>

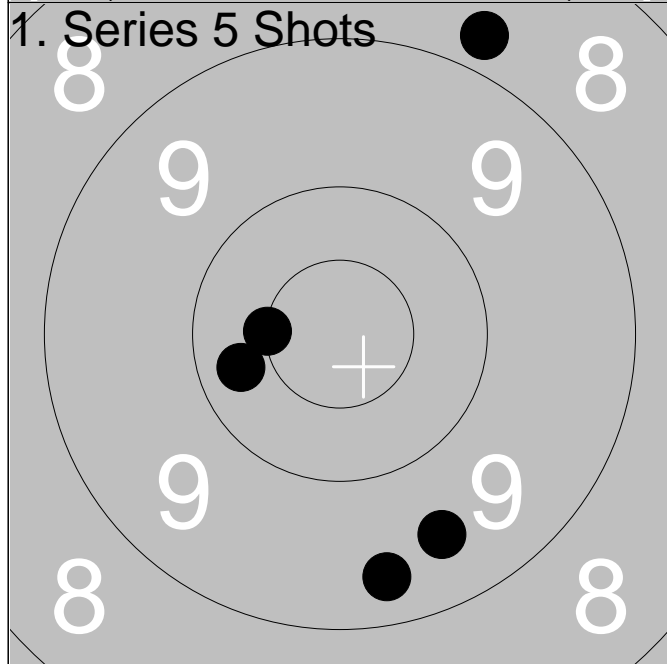

	1:	10.3	←
	2:	9.5	↓
	3:	9.4	↓
	4:	8.8	↑
	5:	*10.5	←
<b>Series</b>			<b>46.0</b>
<b>Total</b>			<b>269.0</b>

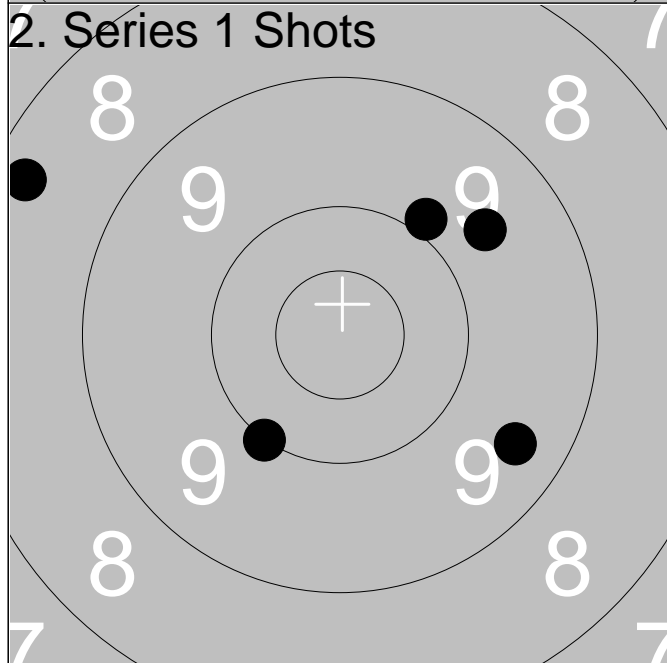

	1:	8.3	←
	2:	9.9	↗
	3:	9.4	↘
	4:	10.0	↙
	5:	9.6	↗
<b>Series</b>			<b>45.0</b>
<b>Total</b>			<b>314.0</b>

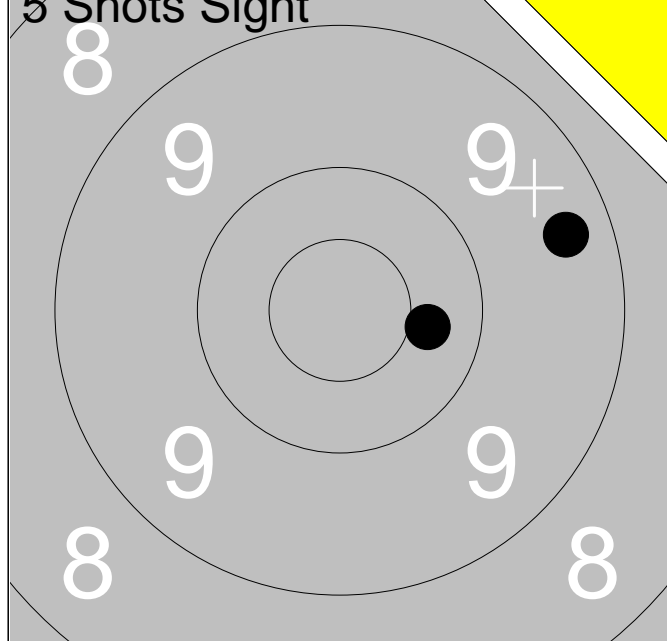

1:	9.4	→
2:	10.4	→
3:	8.1	↗
<b>Series</b>		<b>27.0</b>
<b>Total</b>		<b>222.0</b>

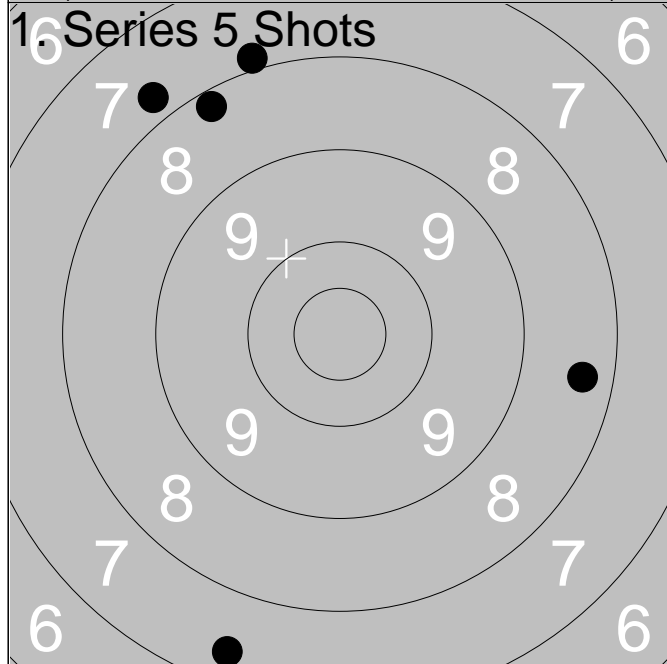

1:	7.8	↗
2:	7.9	↗
3:	8.2	↗
4:	7.4	↘
5:	8.4	→
<b>Series</b>		<b>37.0</b>
<b>Total</b>		<b>259.0</b>

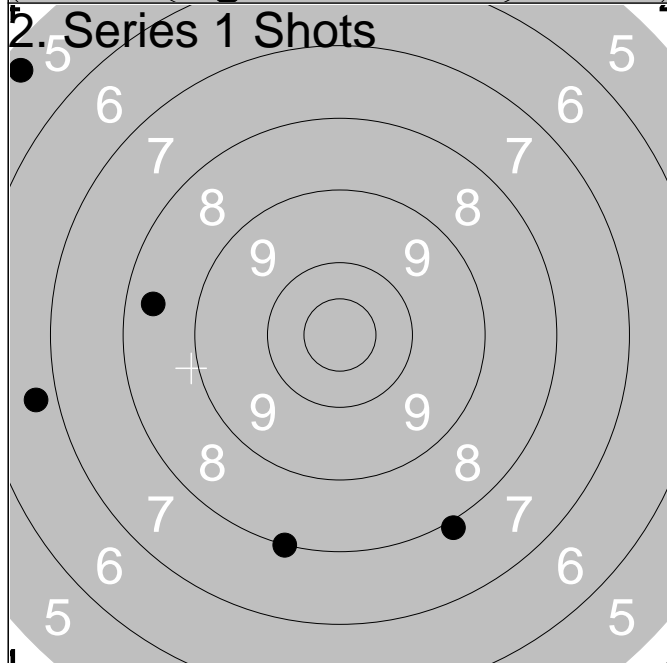

1:	5.3	↗
2:	8.4	←
3:	6.7	←
4:	8.0	↘
5:	7.9	↘
<b>Series</b>		<b>34.0</b>
<b>Total</b>		<b>293.0</b>

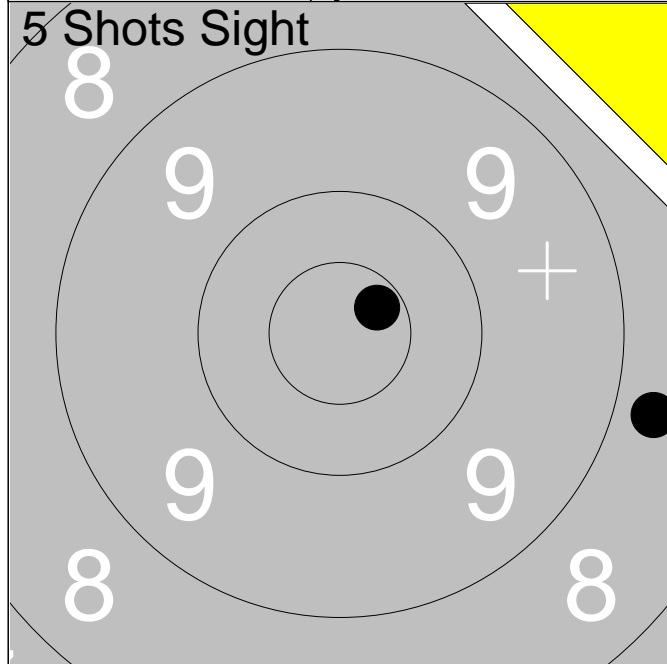

1:	*10.7	↗
2:	8.4	↗
3:	8.7	→
<b>Series</b>		<b>26.0</b>
<b>Total</b>		<b>222.0</b>

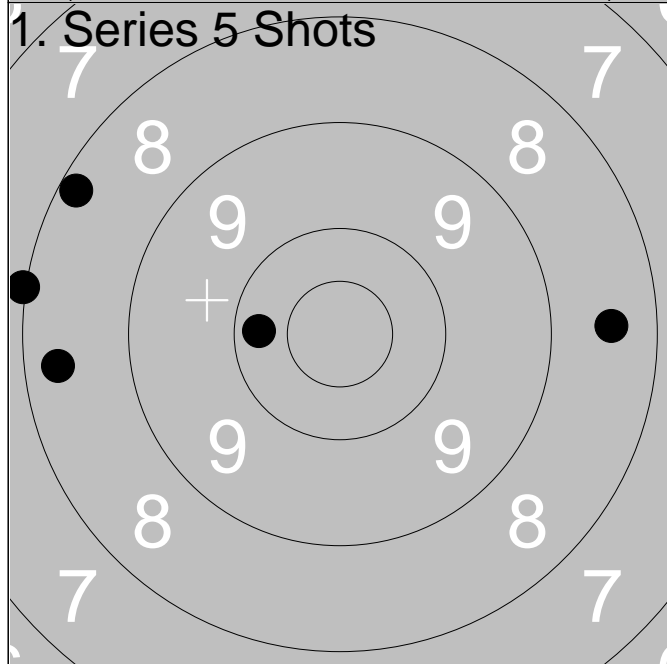

1:	8.2	↖
2:	10.2	←
3:	8.3	←
4:	8.0	←
5:	8.5	→
<b>Series</b>		<b>42.0</b>
<b>Total</b>		<b>264.0</b>

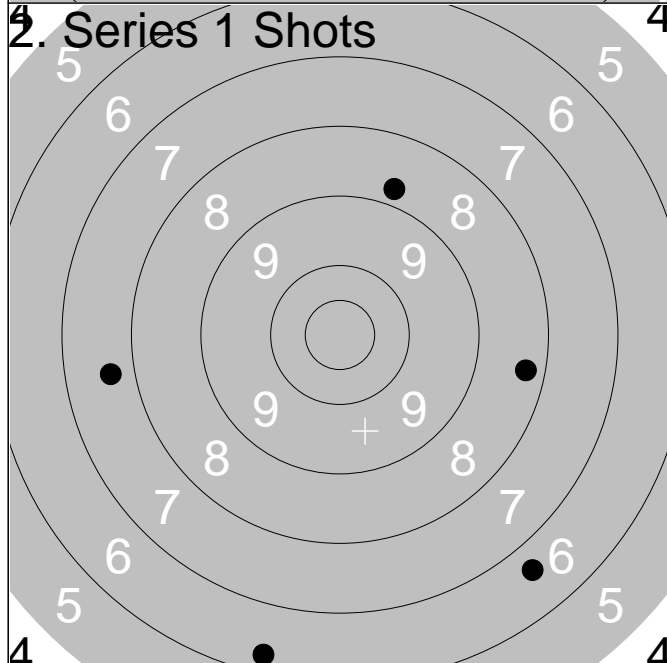

1:	8.3	→
2:	8.8	↑
3:	7.7	←
4:	6.7	↘
5:	6.3	↘
<b>Series</b>		<b>35.0</b>
<b>Total</b>		<b>299.0</b>



	1:	8.2	←
	2:	9.9	↑
	3:	9.3	↗
<hr/>			
Series			26.0
Total			222.0

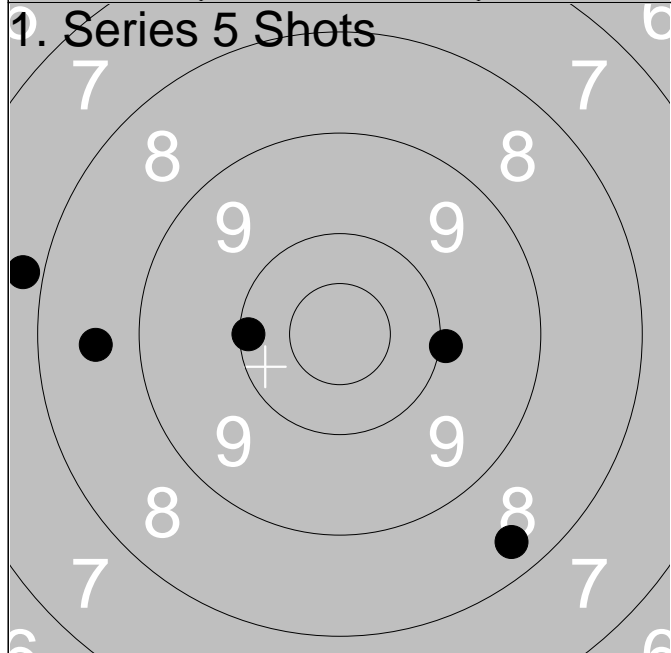

	1:	10.1	←
	2:	7.8	←
	3:	8.6	←
	4:	10.0	→
	5:	8.4	↘
<hr/>			
Series			43.0
Total			265.0

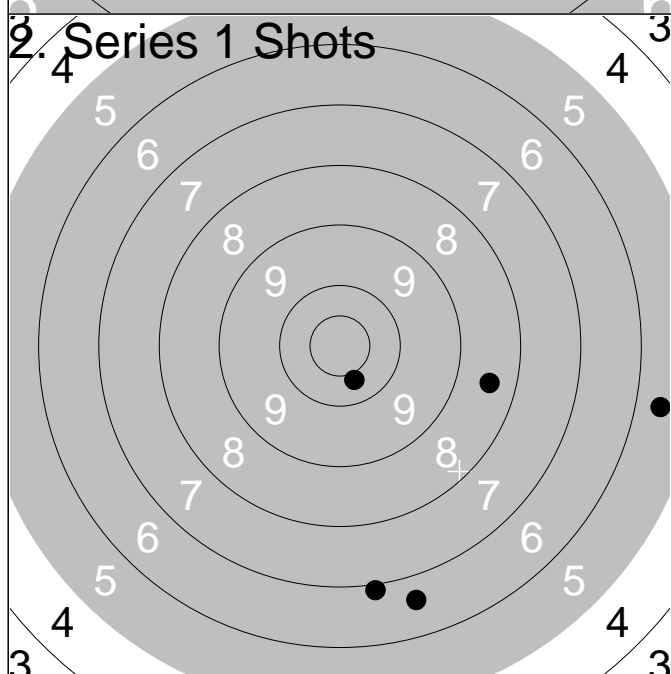

	1:	6.6	↓
	2:	10.4	↓
	3:	8.5	→
	4:	6.9	↓
	5:	5.6	→
<hr/>			
Series			35.0
Total			300.0



1:	*10.7	↓
2:	10.1	↓
3:	10.0	→
Series		30.0
Total		218.0

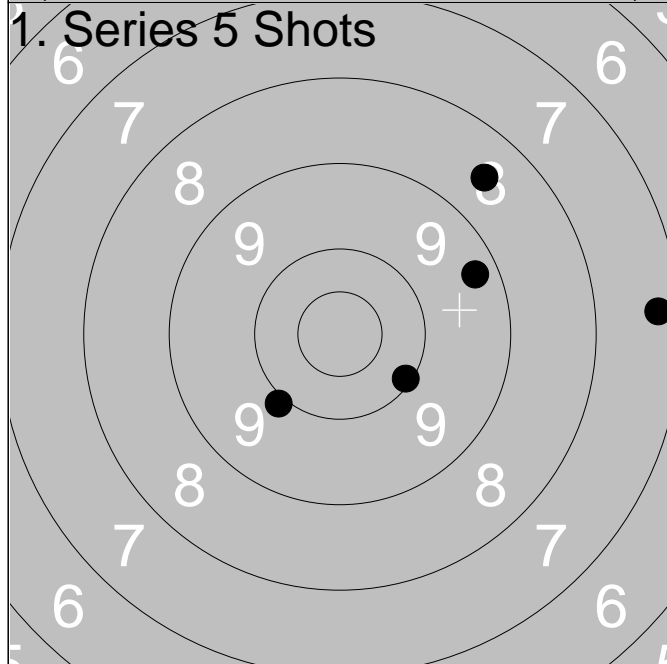

1:	9.3	↗
2:	9.9	↘
3:	8.5	↗
4:	10.1	↘
5:	7.3	→
Series		43.0
Total		261.0

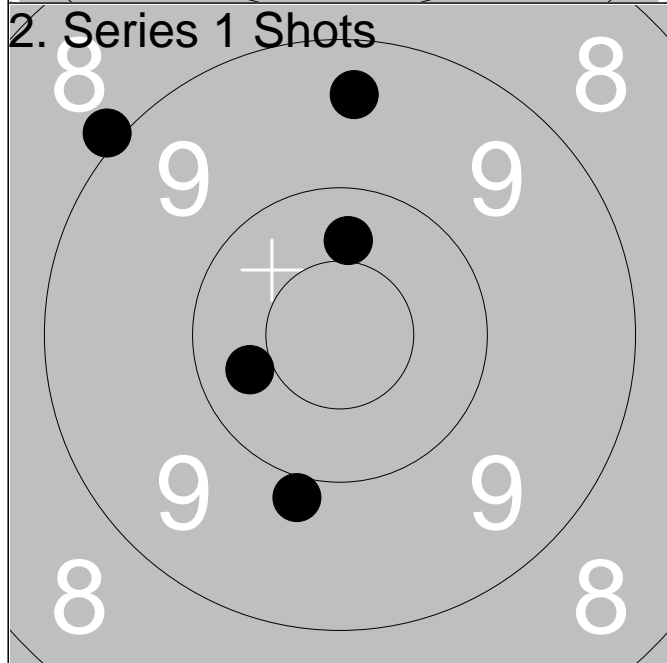

1:	8.9	↖
2:	9.4	↑
3:	10.4	↑
4:	10.3	↖
5:	9.9	↓
Series		46.0
Total		307.0





1:	10.0	→
2:	10.2	↓
3:	*10.5	↙
<b>Series</b>	<b>30.0</b>	
<b>Total</b>	<b>216.0</b>	

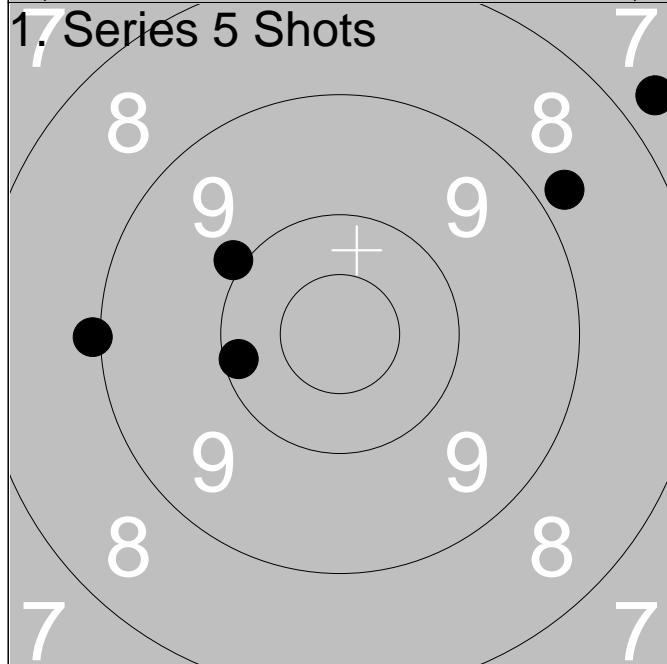

1:	9.9	↖
2:	7.7	↗
3:	10.1	←
4:	8.8	↗
5:	9.0	←
<b>Series</b>	<b>43.0</b>	
<b>Total</b>	<b>259.0</b>	

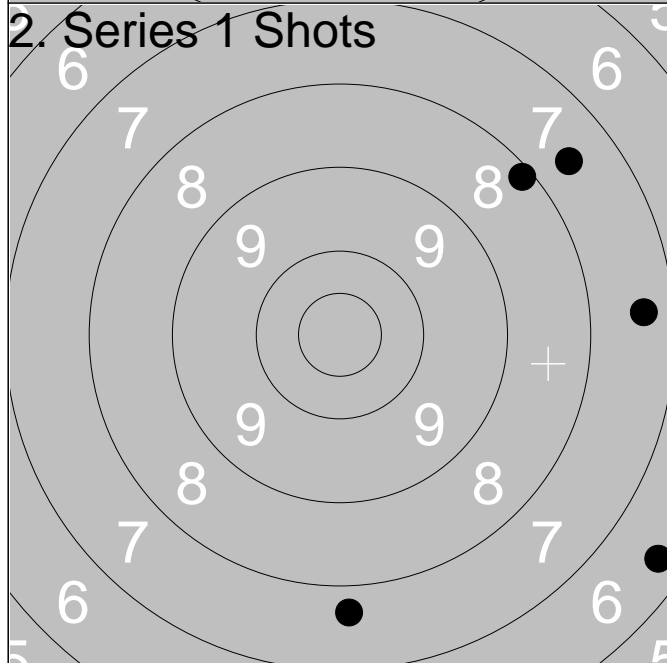

1:	6.4	↘
2:	7.6	↗
3:	8.2	↗
4:	7.4	→
5:	7.7	↓
<b>Series</b>	<b>35.0</b>	
<b>Total</b>	<b>294.0</b>	



1:	9.5	→
2:	8.5	↓
3:	9.5	←
<b>Series</b>		<b>26.0</b>
<b>Total</b>		<b>211.0</b>

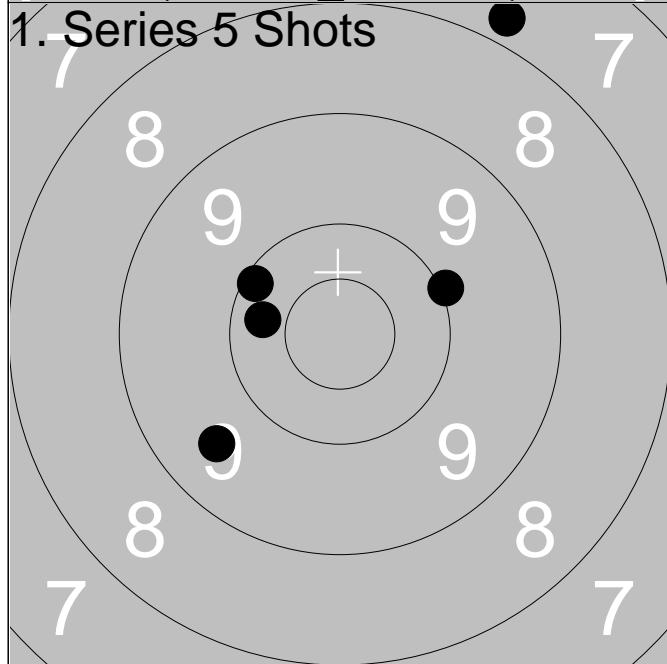

1:	9.5	↙
2:	7.8	↗
3:	10.0	→
4:	10.3	←
5:	10.1	↖
<b>Series</b>		<b>46.0</b>
<b>Total</b>		<b>257.0</b>

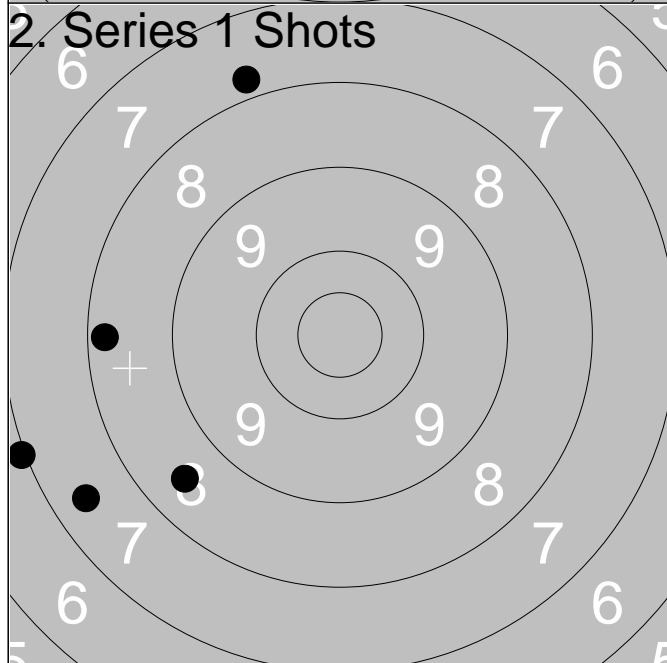

1:	8.5	↙
2:	8.2	←
3:	7.8	↗
4:	7.4	↙
5:	7.0	←
<b>Series</b>		<b>37.0</b>
<b>Total</b>		<b>294.0</b>

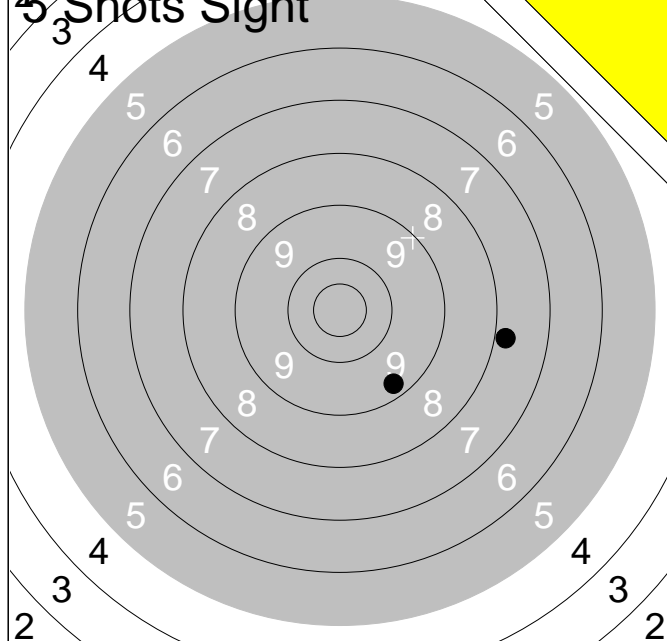

	1:	7.8	→
	2:	4.9	↑
	3:	9.3	↓
<b>Series</b>			<b>20.0</b>
<b>Total</b>			<b>207.0</b>

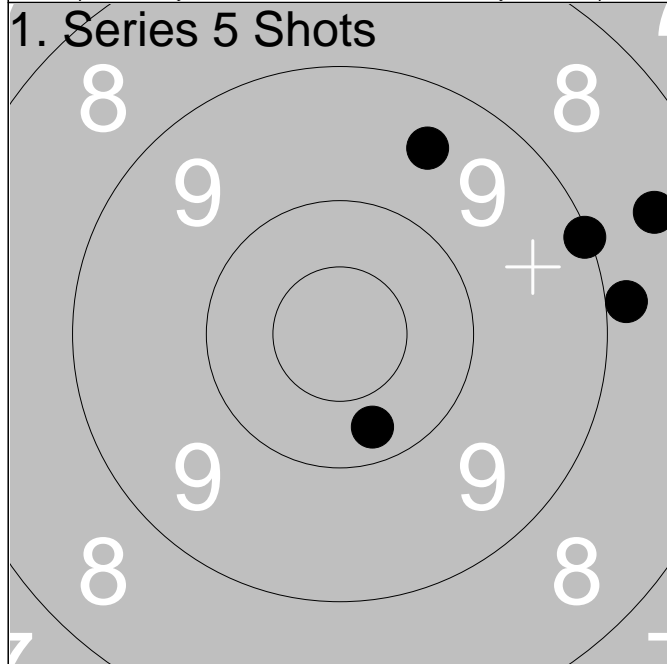

	1:	8.5	→
	2:	10.3	↓
	3:	8.9	→
	4:	9.1	→
	5:	9.5	↑
<b>Series</b>			<b>44.0</b>
<b>Total</b>			<b>251.0</b>

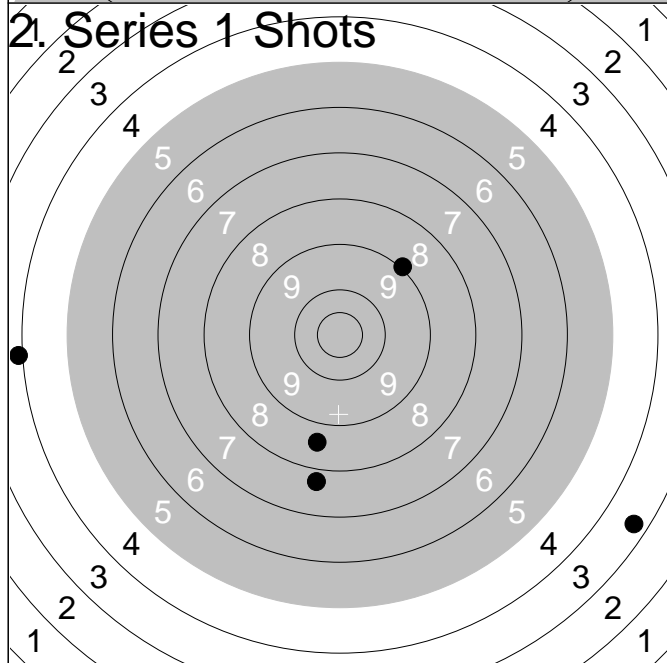

	1:	3.9	←
	2:	8.6	↓
	3:	3.3	→
	4:	9.0	↗
	5:	7.8	↓
<b>Series</b>			<b>30.0</b>
<b>Total</b>			<b>281.0</b>

Relay <b>5</b>	Lane <b>14</b>	<b>Elina Johansson</b>
-------------------	-------------------	------------------------

300m	Ale	SenB	No
------	-----	------	----

2013-07-06	Björkskottet 2013	Ramselefors SKF
------------	-------------------	-----------------

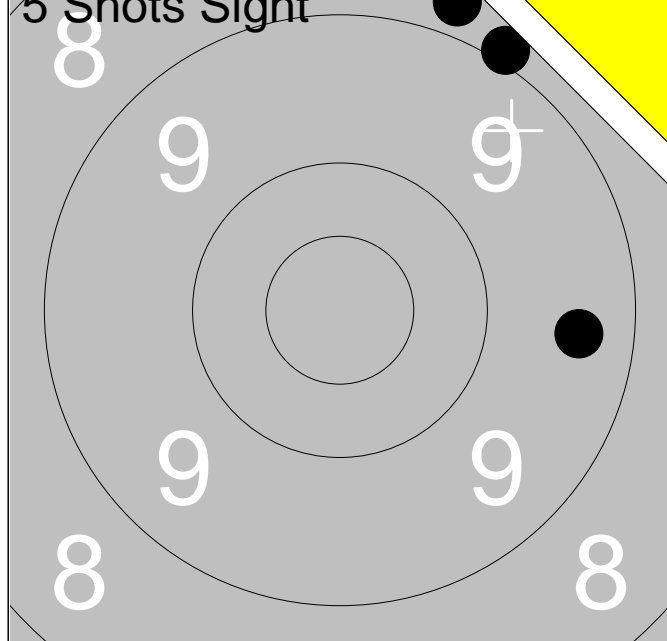

1:	8.8	↑
2:	9.4	→
3:	8.9	↑
Series		25.0
Total		203.0

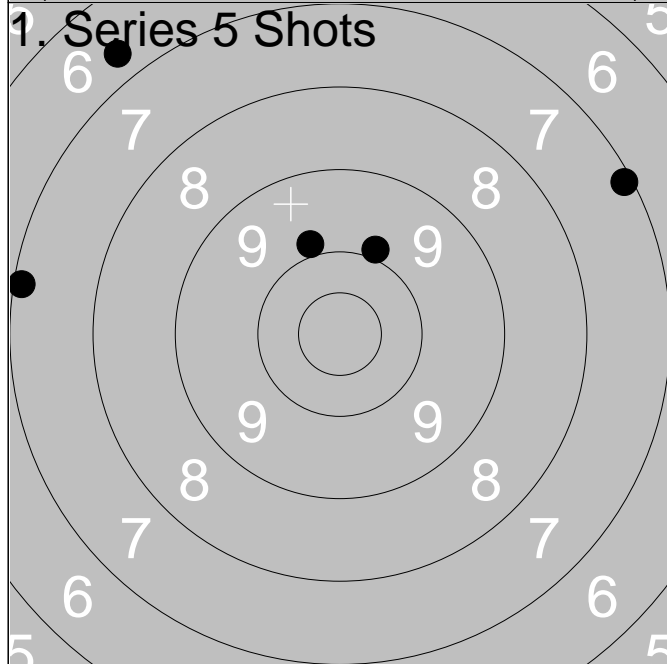

1:	7.1	↗
2:	6.7	↖
3:	9.9	↑
4:	9.9	↑
5:	7.1	←
Series		38.0
Total		241.0

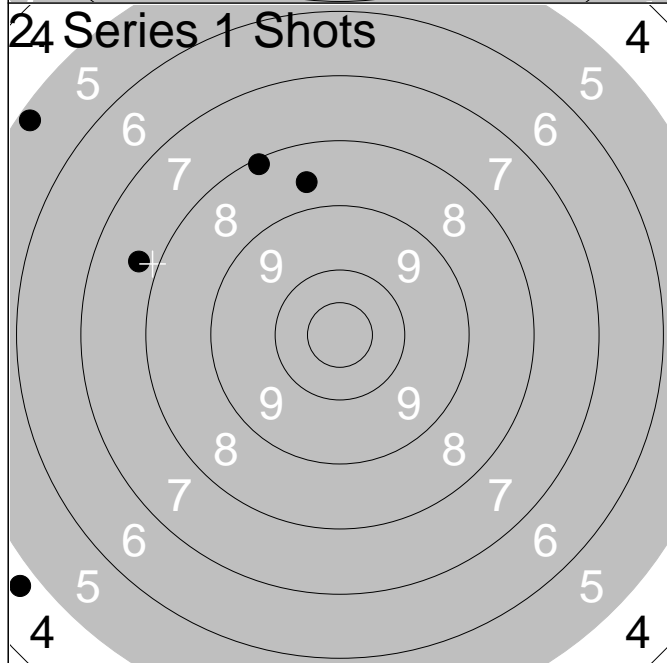

1:	8.1	↑
2:	5.2	↖
3:	8.6	↑
4:	4.7	↖
5:	7.7	↖
Series		32.0
Total		273.0

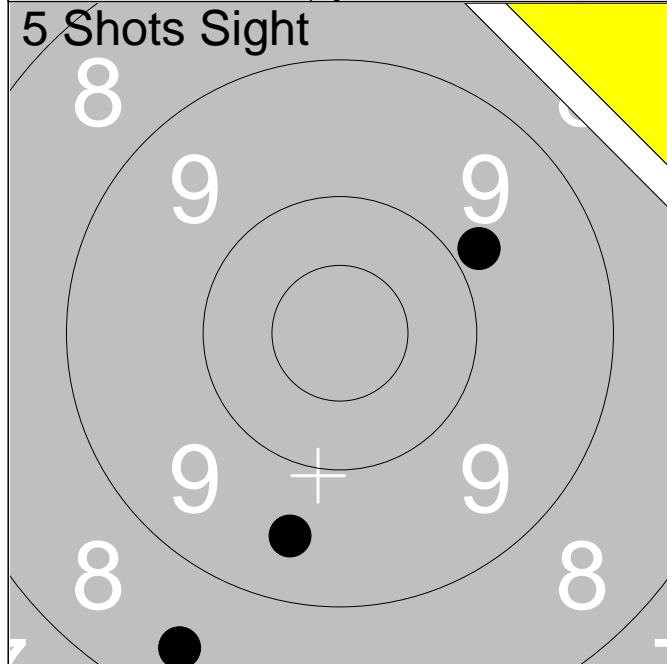

1:	8.5	↙
2:	9.5	↘
3:	9.8	↗
Series	26.0	
Total	201.0	

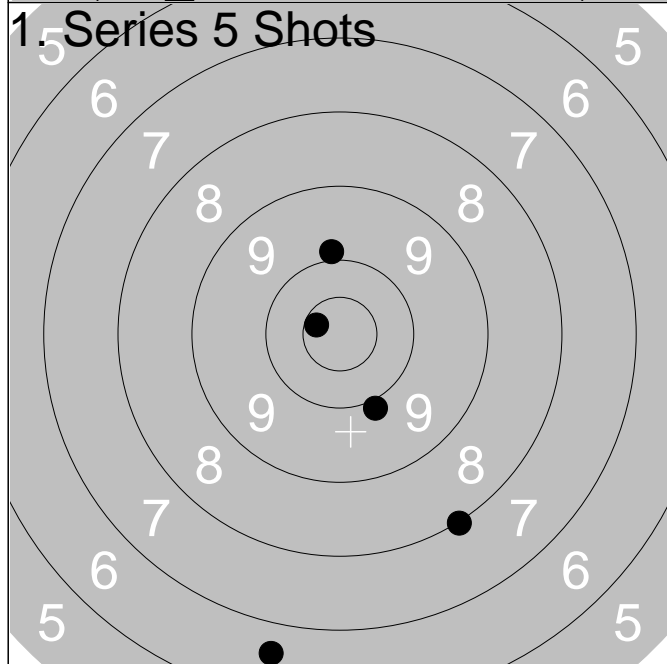

1:	9.9	↑
2:	9.9	↘
3:	8.0	↘
4:	6.6	↘
5:	*10.6	↗
Series	42.0	
Total	243.0	

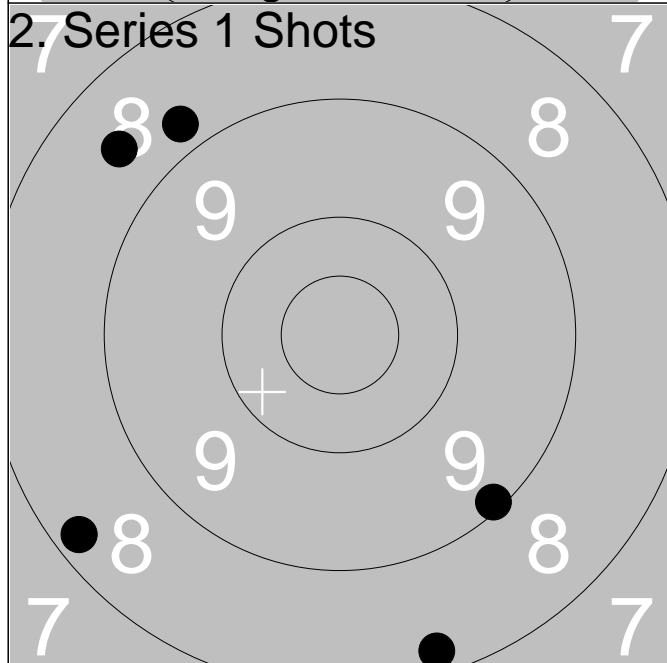

1:	8.2	↘
2:	8.6	↗
3:	8.8	↗
4:	8.2	↘
5:	9.1	↘
Series	41.0	
Total	284.0	

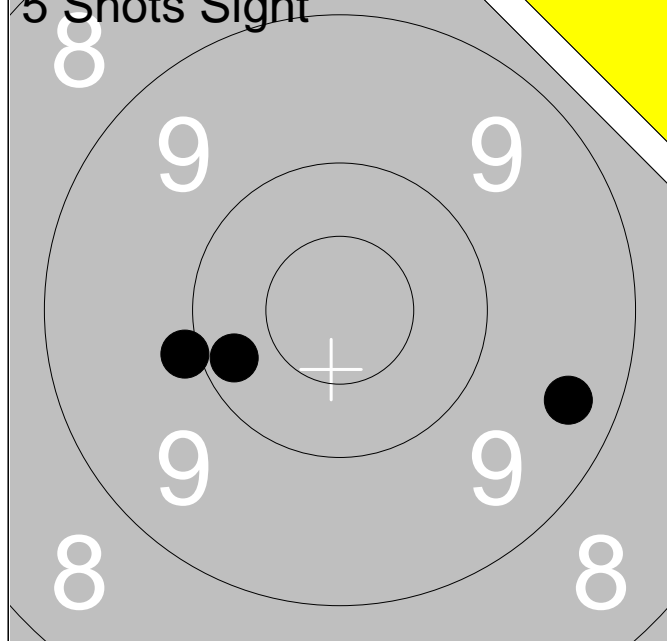

	1:	10.2	←
	2:	9.9	←
	3:	9.4	→
<b>Series</b>			<b>28.0</b>
<b>Total</b>			<b>236.0</b>

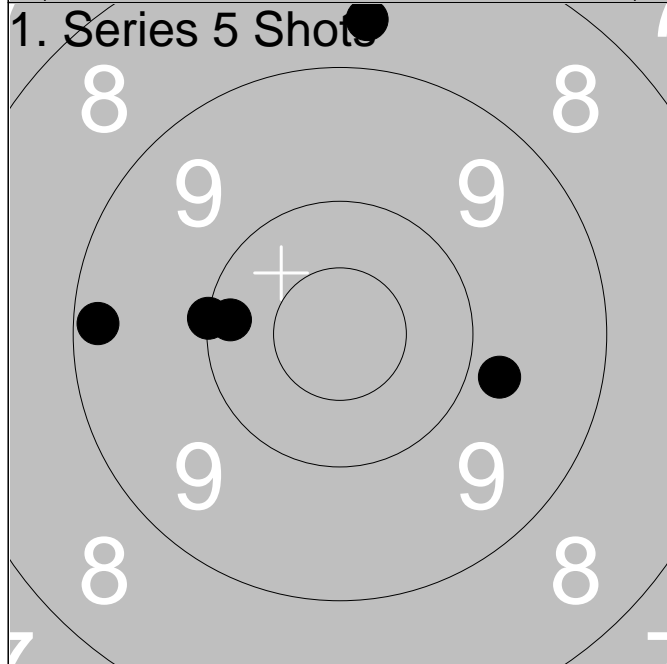

	1:	8.7	↑
	2:	10.0	←
	3:	9.8	→
	4:	10.2	←
	5:	9.2	←
<b>Series</b>			<b>46.0</b>
<b>Total</b>			<b>282.0</b>

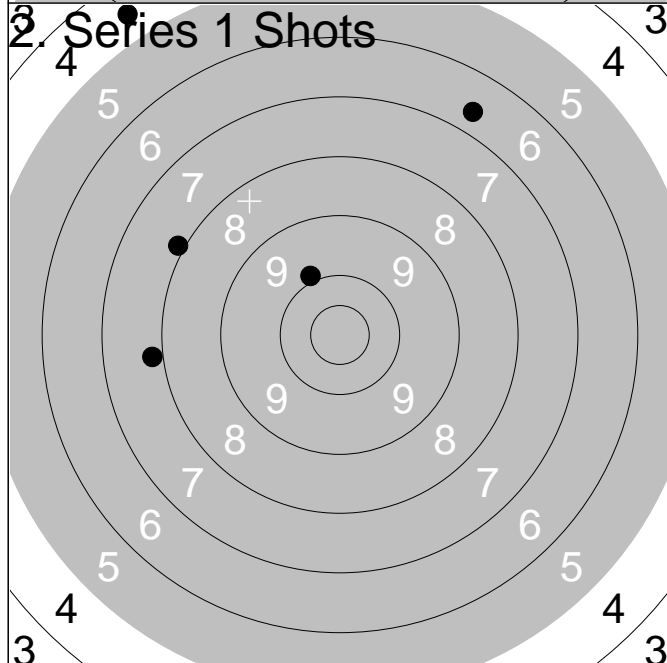

	1:	4.6	↗
	2:	7.9	↗
	3:	7.9	←
	4:	6.7	↗
	5:	9.9	↗
<b>Series</b>			<b>33.0</b>
<b>Total</b>			<b>315.0</b>

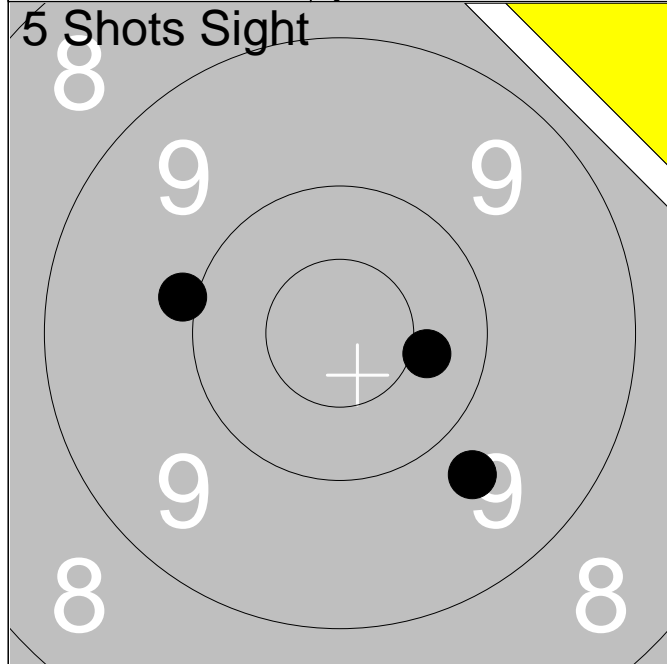

1:	10.4	→
2:	9.9	←
3:	9.7	↘
<b>Series</b>		<b>28.0</b>
<b>Total</b>		<b>235.0</b>

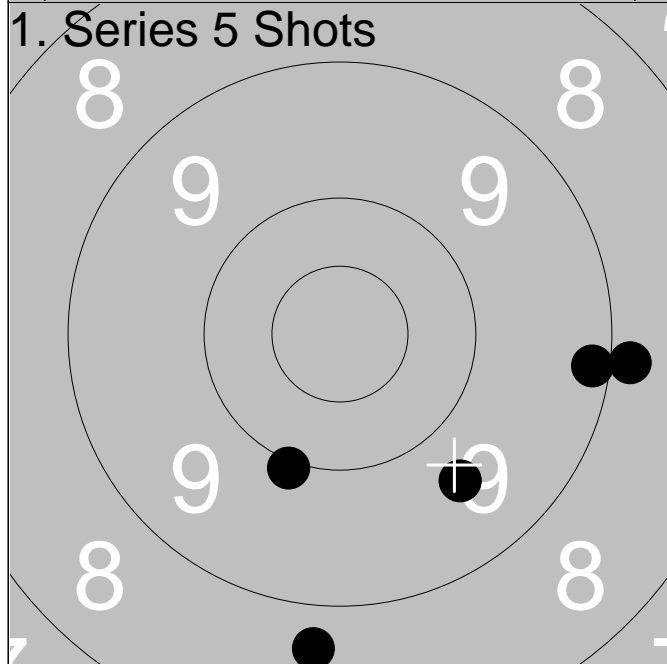

1:	8.9	→
2:	8.7	↓
3:	9.2	→
4:	9.6	↘
5:	10.0	↘
<b>Series</b>		<b>44.0</b>
<b>Total</b>		<b>279.0</b>

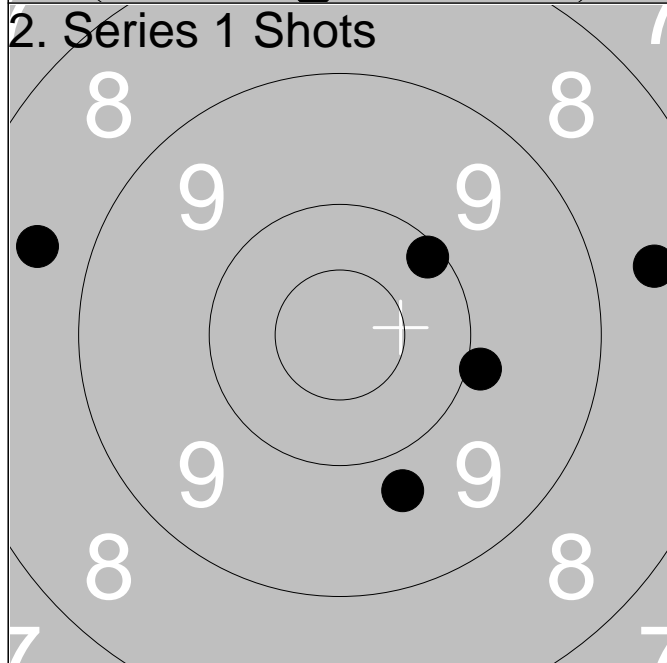

1:	8.6	←
2:	10.1	↗
3:	9.9	→
4:	9.7	↘
5:	8.6	→
<b>Series</b>		<b>44.0</b>
<b>Total</b>		<b>323.0</b>

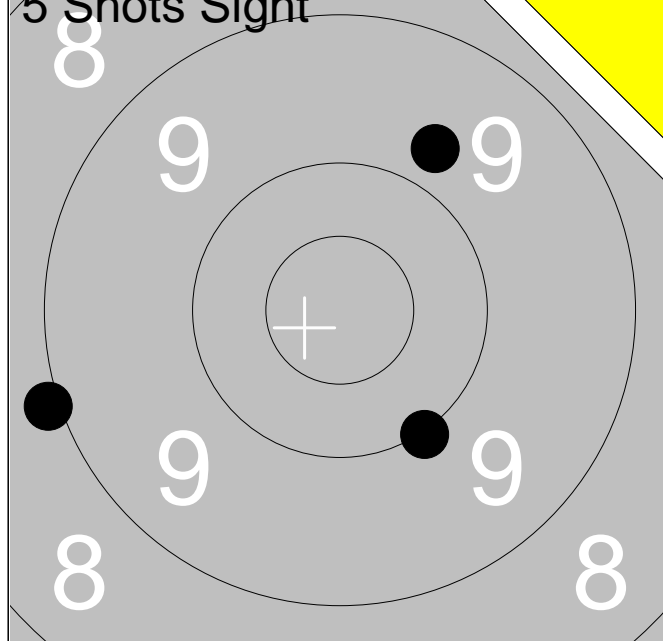

	1:	9.0	←
	2:	9.8	↗
	3:	10.0	↘
<b>Series</b>			<b>28.0</b>
<b>Total</b>			<b>233.0</b>

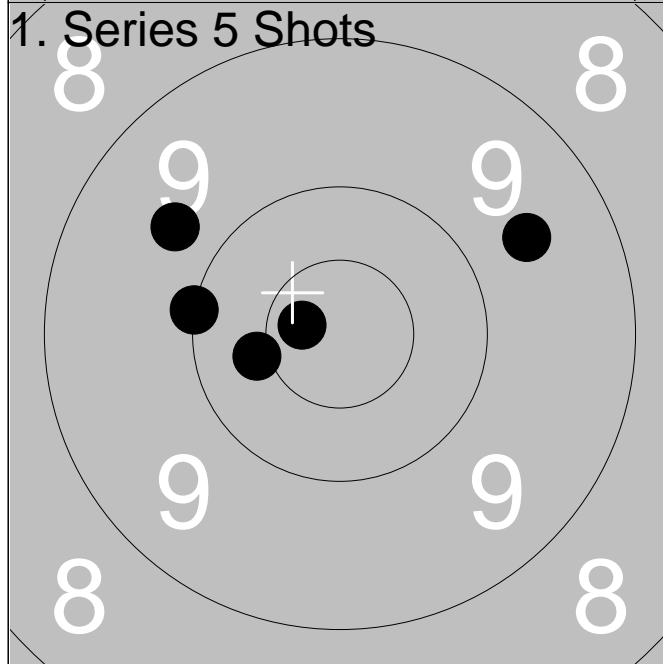

	1:	9.7	↖
	2:	*10.7	←
	3:	10.0	←
	4:	9.6	↗
	5:	10.4	←
<b>Series</b>			<b>48.0</b>
<b>Total</b>			<b>281.0</b>

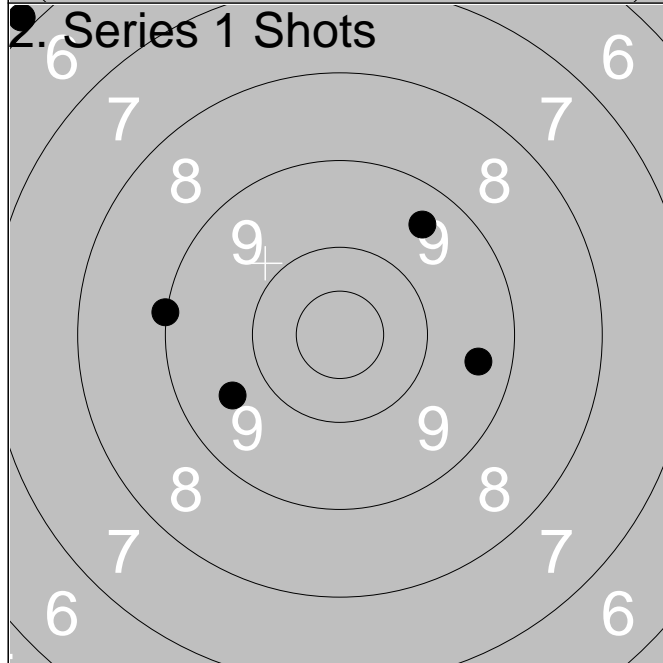

	1:	5.9	↖
	2:	9.5	↗
	3:	9.0	←
	4:	9.4	→
	5:	9.6	←
<b>Series</b>			<b>41.0</b>
<b>Total</b>			<b>322.0</b>





1:	10.2	↙
2:	9.9	↗
3:	*10.9	↘
<b>Series</b>		<b>29.0</b>
<b>Total</b>		<b>232.0</b>

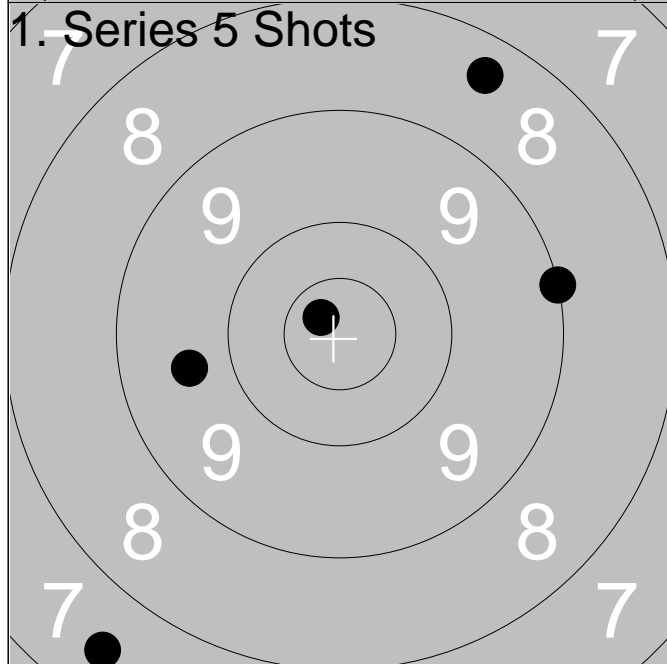

1:	7.5	↙
2:	9.0	→
3:	8.4	↗
4:	9.6	↖
5:	*10.7	↗
<b>Series</b>		<b>43.0</b>
<b>Total</b>		<b>275.0</b>

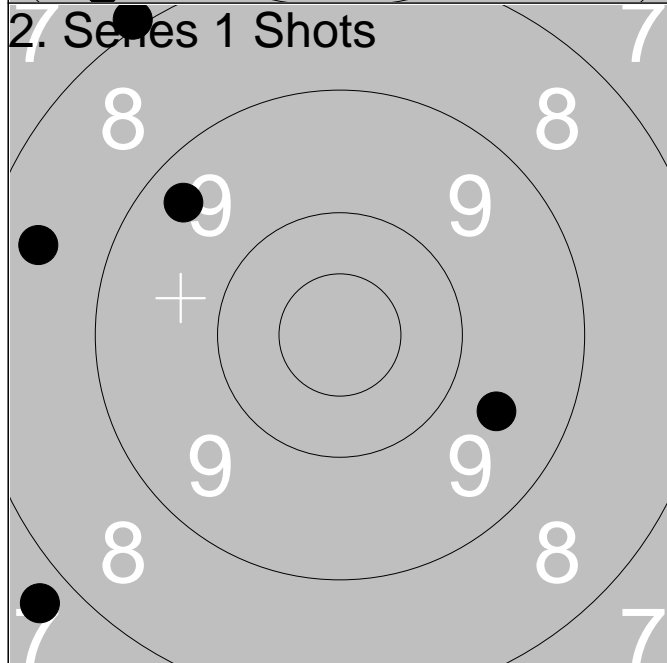

1:	7.7	↙
2:	8.5	↖
3:	8.0	↗
4:	9.4	↗
5:	9.6	↘
<b>Series</b>		<b>41.0</b>
<b>Total</b>		<b>316.0</b>

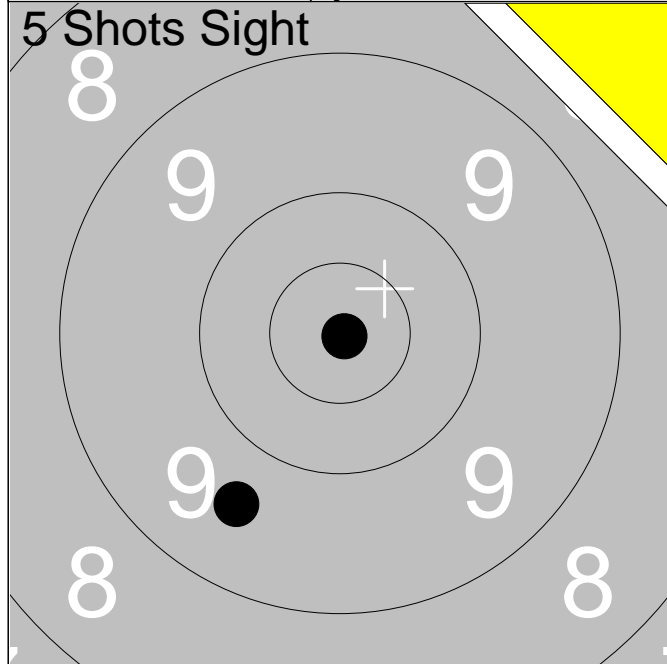

1:	9.6	↙
2:	8.2	↗
3:	*10.9	↘
<b>Series</b>		<b>27.0</b>
<b>Total</b>		<b>229.0</b>

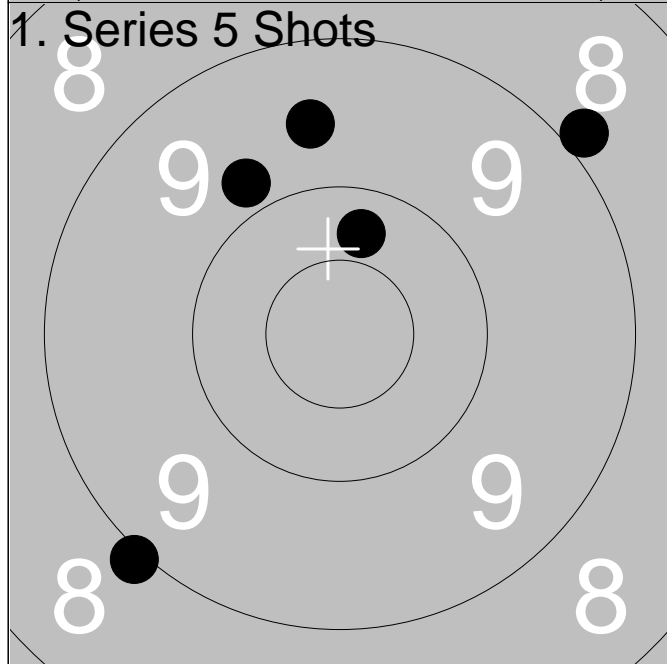

1:	10.3	↑
2:	9.6	↑
3:	8.9	↗
4:	9.8	↖
5:	9.0	↘
<b>Series</b>		<b>45.0</b>
<b>Total</b>		<b>274.0</b>

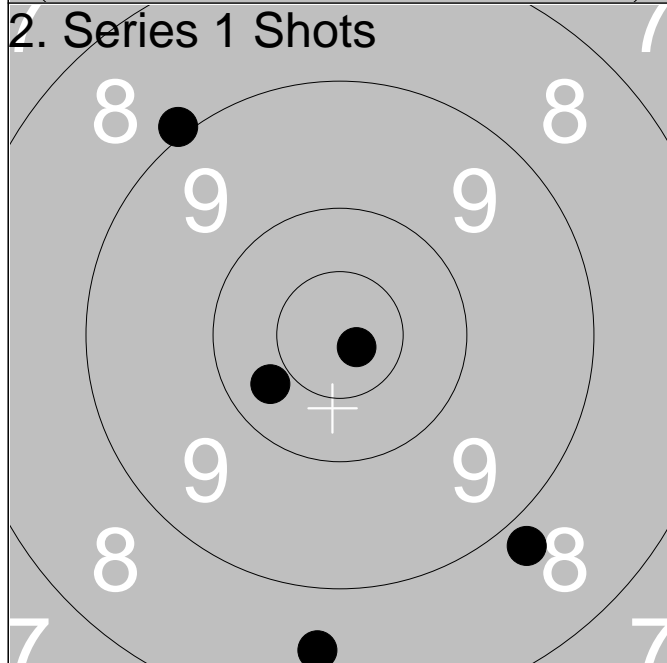

1:	8.5	↓
2:	8.8	↘
3:	9.0	↗
4:	*10.8	↘
5:	10.3	↙
<b>Series</b>		<b>45.0</b>
<b>Total</b>		<b>319.0</b>

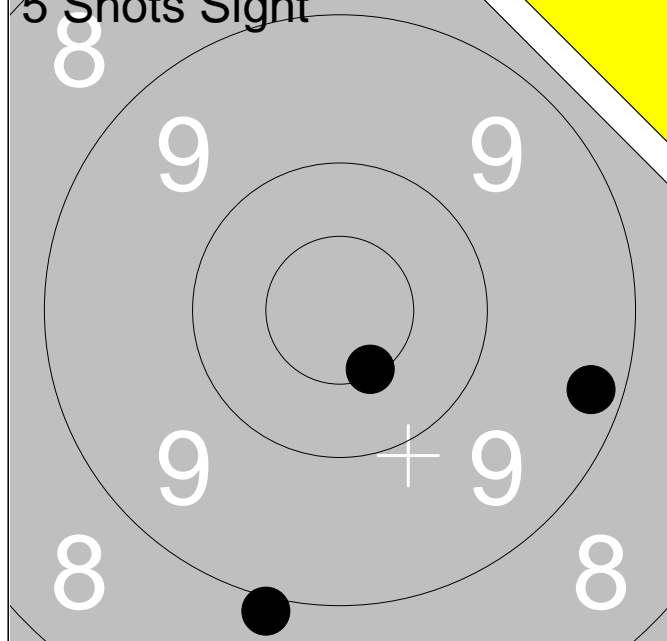

1:	*10.5	↘
2:	8.9	↘
3:	9.2	→
<b>Series</b>		<b>27.0</b>
<b>Total</b>		<b>228.0</b>

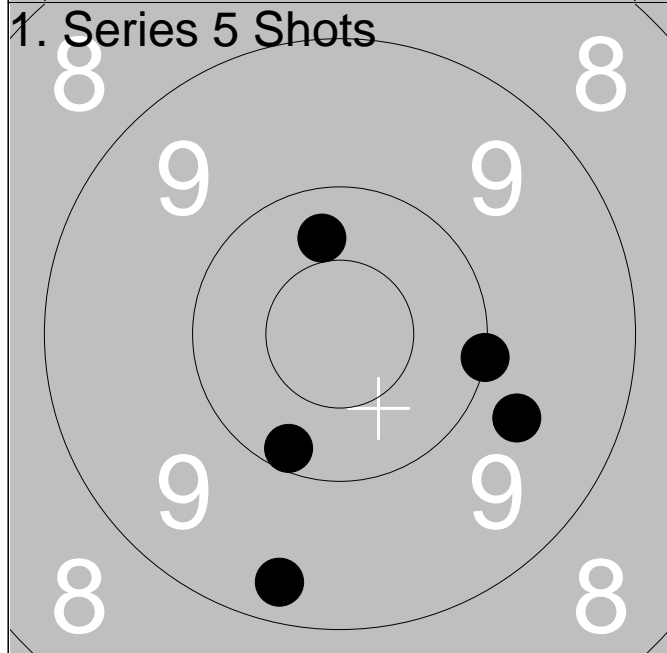

1:	10.0	→
2:	9.7	↘
3:	10.2	↘
4:	9.3	↘
5:	10.3	↑
<b>Series</b>		<b>48.0</b>
<b>Total</b>		<b>276.0</b>

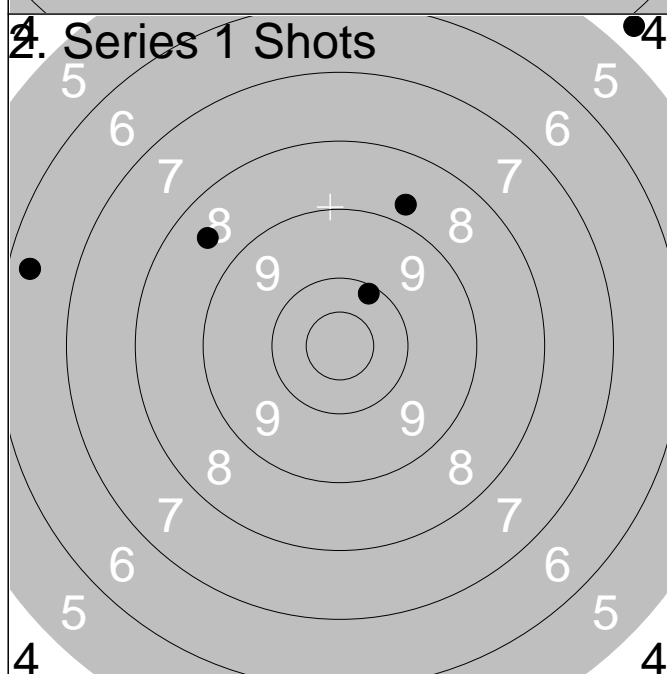

1:	6.4	←
2:	4.7	↗
3:	8.5	↖
4:	8.8	↗
5:	10.1	↗
<b>Series</b>		<b>36.0</b>
<b>Total</b>		<b>312.0</b>



	1:	8.6	↑
	2:	*10.6	↖
	3:	7.3	↗
<b>Series</b>			<b>25.0</b>
<b>Total</b>			<b>225.0</b>

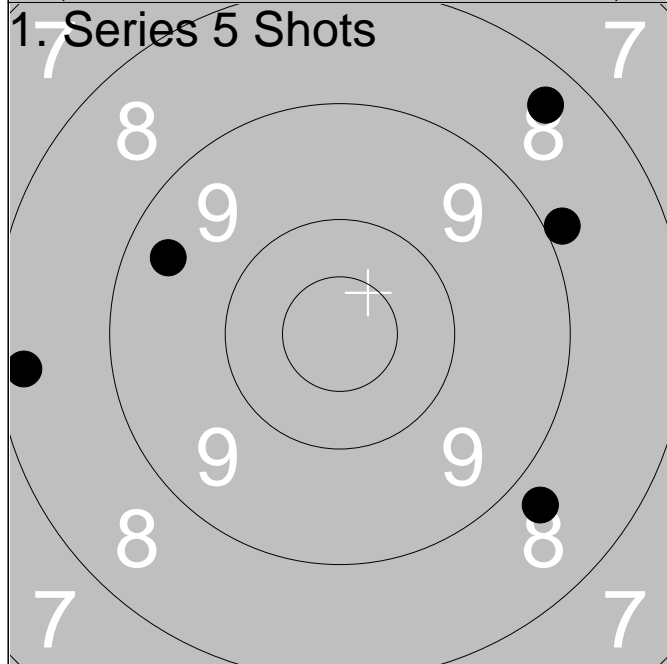

	1:	8.4	↗
	2:	8.3	←
	3:	9.4	↖
	4:	8.9	↗
	5:	8.7	↘
<b>Series</b>			<b>41.0</b>
<b>Total</b>			<b>266.0</b>

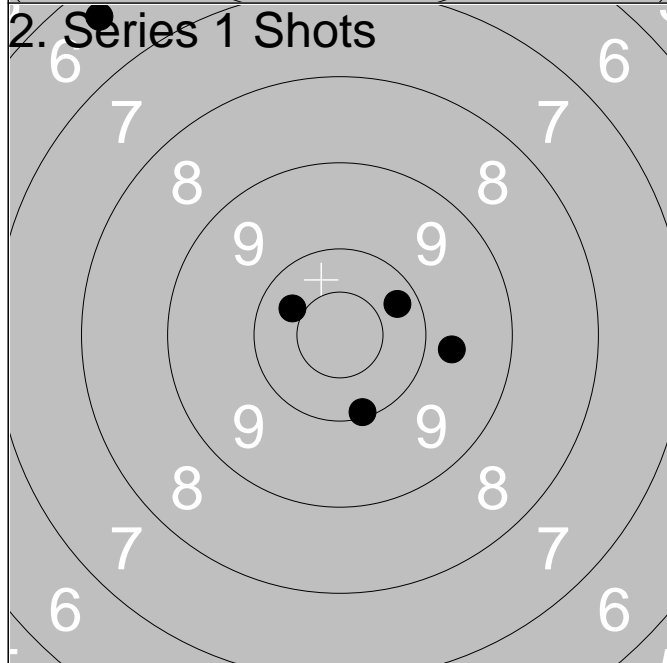

	1:	6.4	↗
	2:	10.3	↗
	3:	10.4	↖
	4:	9.7	→
	5:	10.1	↘
<b>Series</b>			<b>45.0</b>
<b>Total</b>			<b>311.0</b>

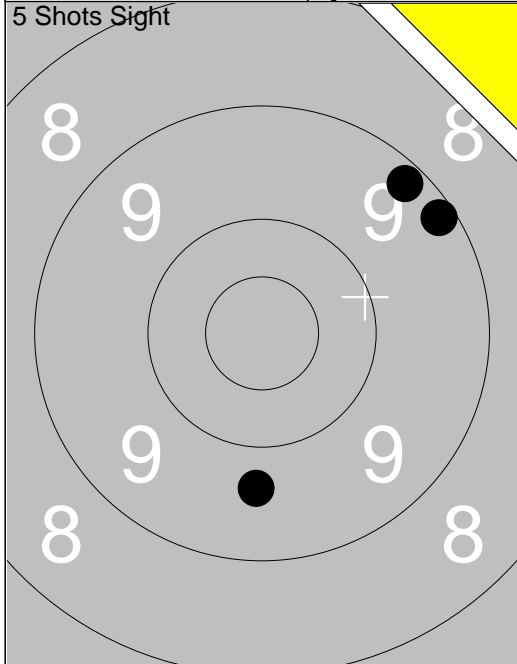

1: 9.2 ↗
2: 9.7 ↓
3: 9.2 ↗
Series 27.0
Total 236.0

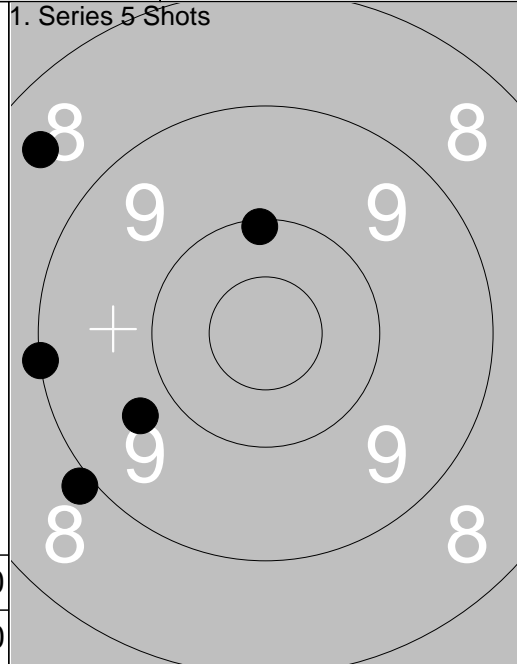

1: 8.5 ↖
2: 9.0 ←
3: 8.9 ↙
4: 9.7 ↙
5: 10.1 ↑
Series 44.0
Total 280.0

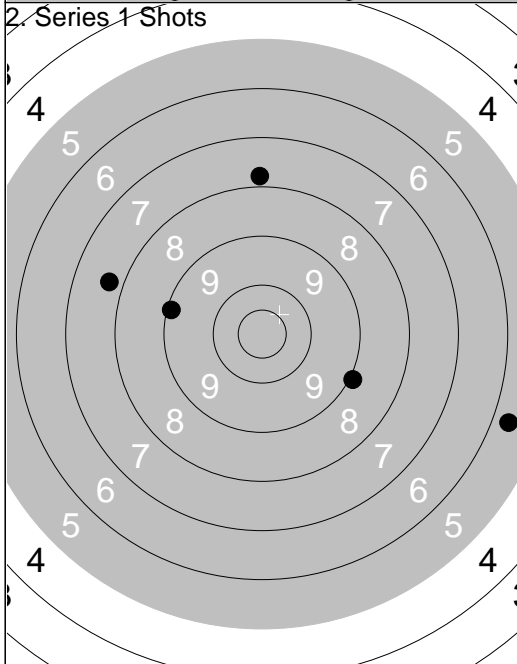

1: 7.8 ↑
2: 9.0 →
3: 7.7 ←
4: 5.7 →
5: 9.1 ←
Series 37.03
Total 317.0

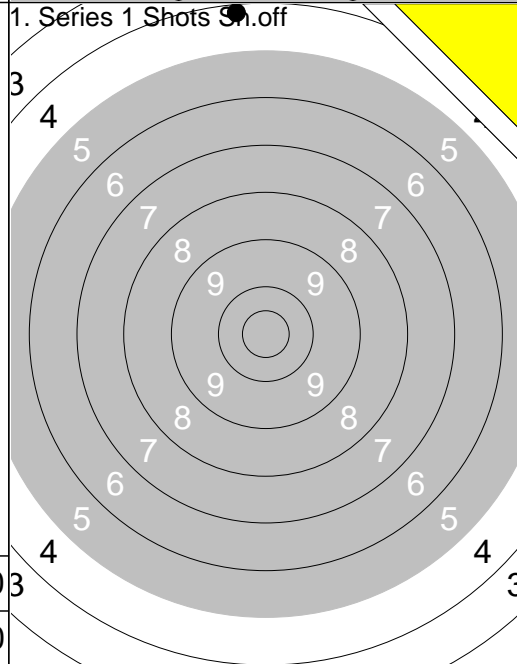

1: 4.2 ↑
Series 4.0
Total 317.0

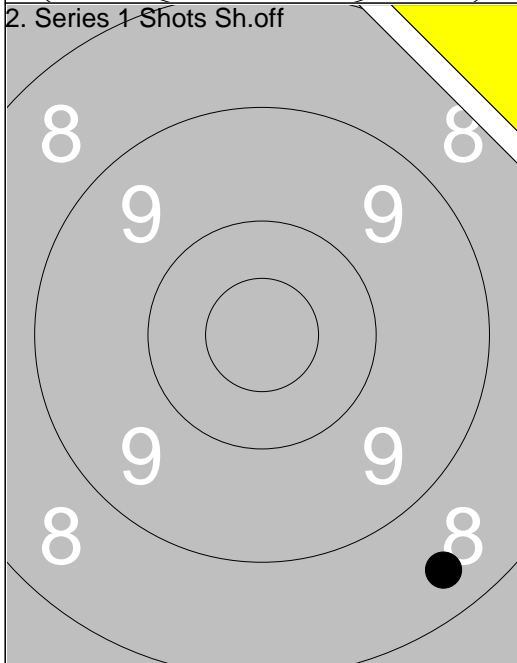

1: 8.4 ↓
Series 8.0
Total 317.0

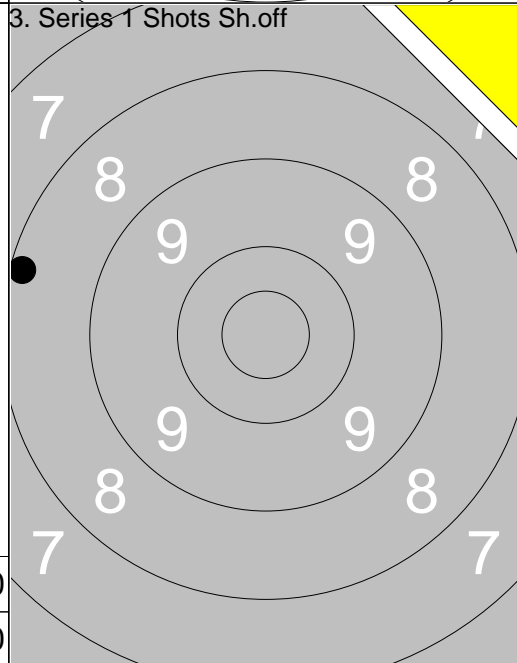

1: 8.2 ←
Series 8.0
Total 317.0

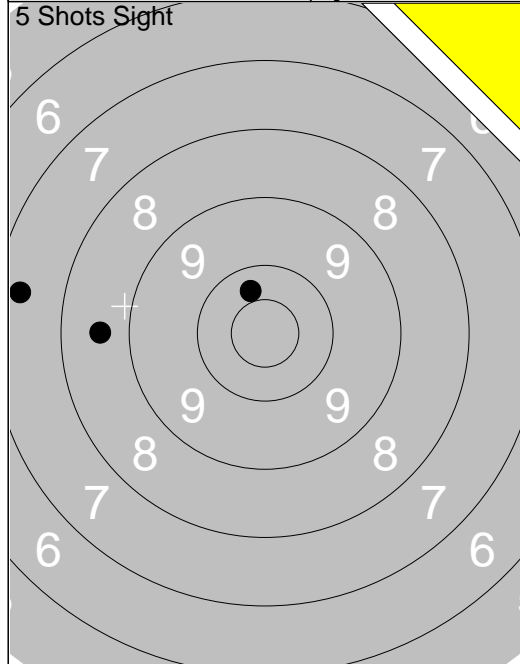

1: 8.6 ←	
2: 7.4 ←	
3: 10.3 ↑	
<b>Series 25.0</b>	
<b>Total 230.0</b>	

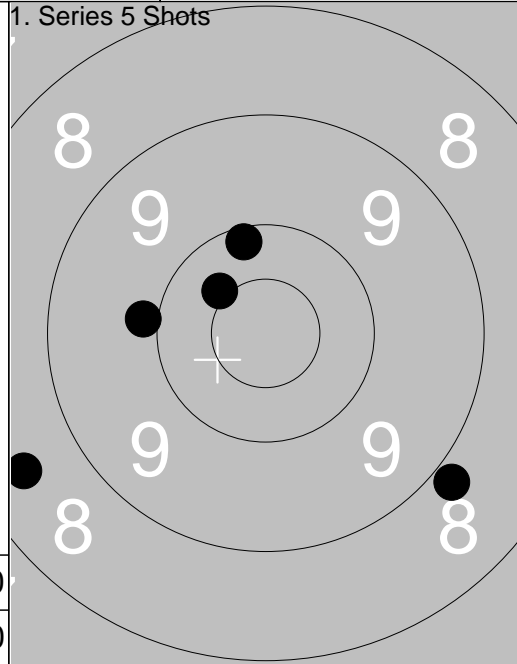

1: 9.9 ←	
2: 10.2 ↑	
3: *10.4 ↙	
4: 8.8 ↘	
5: 8.5 ←	
<b>Series 45.0</b>	
<b>Total 275.0</b>	

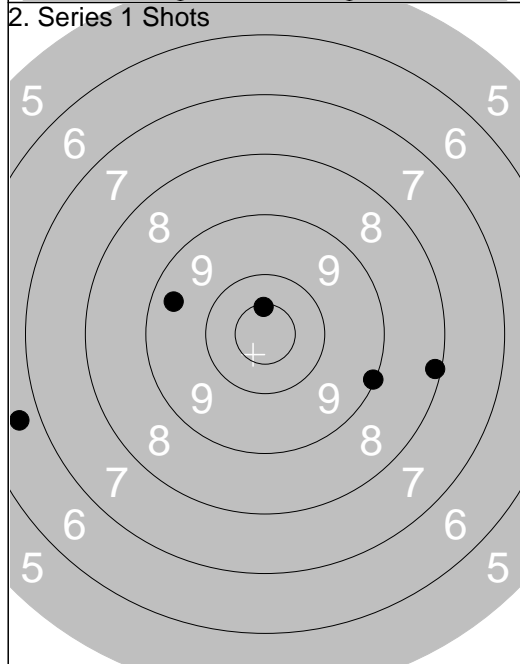

1: *10.5 ↑	
2: 8.1 →	
3: 9.4 ←	
4: 6.7 ←	
5: 9.1 →	
<b>Series 42.0</b>	
<b>Total 317.0</b>	

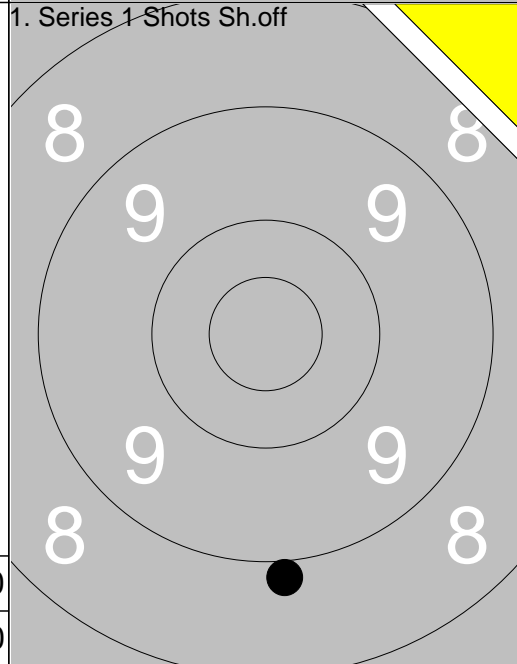

1: 8.9 ↓	
<b>Series 8.0</b>	
<b>Total 317.0</b>	

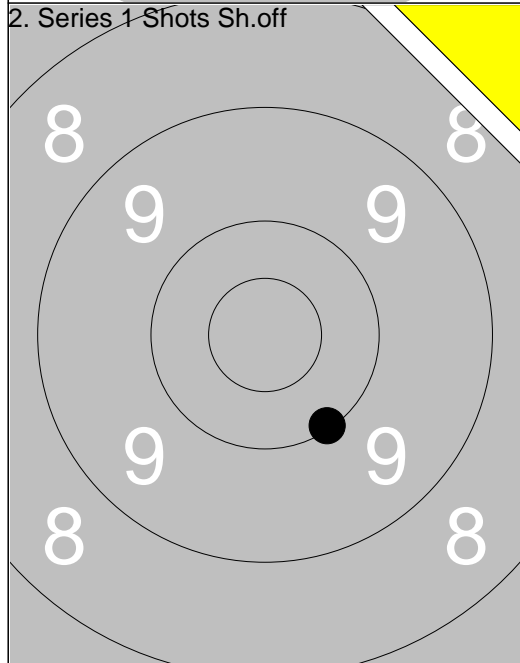

1: 10.1 ↓	
<b>Series 10.0</b>	
<b>Total 317.0</b>	

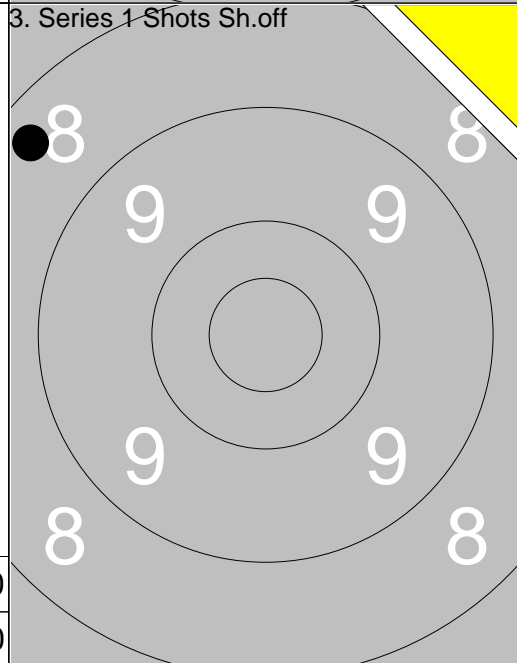

1: 8.4 ↙	
<b>Series 8.0</b>	
<b>Total 317.0</b>	

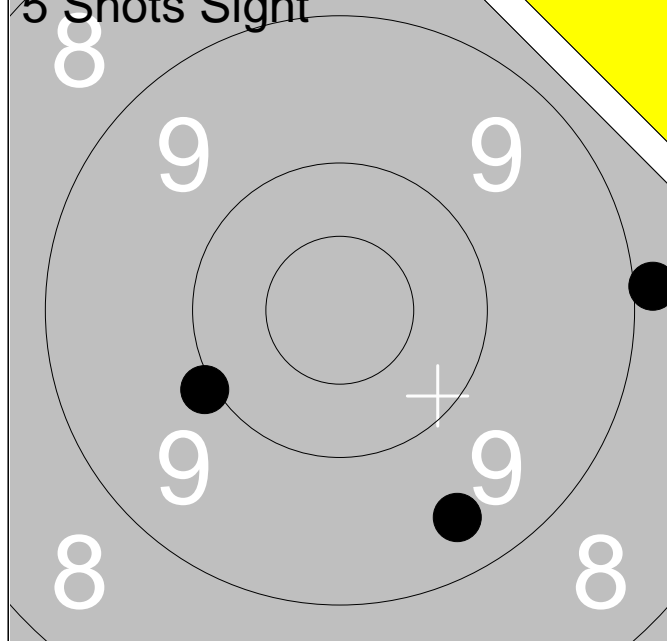

	1:	9.4	↘
	2:	8.9	→
	3:	10.0	↙
<b>Series</b>			<b>27.0</b>
<b>Total</b>			<b>225.0</b>

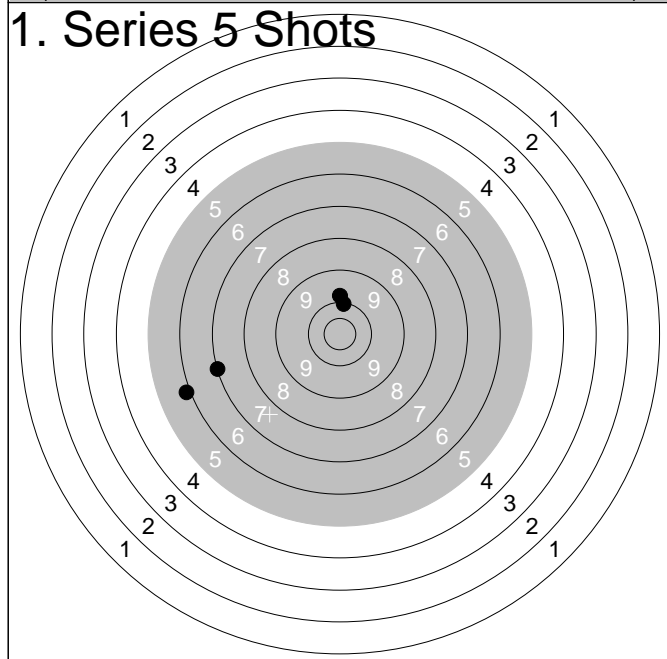

	1:	10.1	↑
	2:	0.0	↓
	3:	5.9	↙
	4:	9.8	↑
	5:	7.0	↙
<b>Series</b>			<b>31.0</b>
<b>Total</b>			<b>256.0</b>

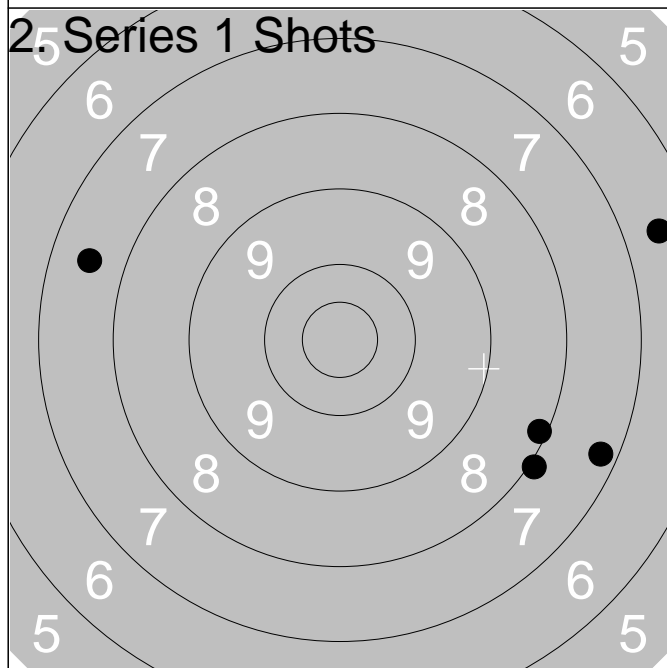

	1:	7.5	↙
	2:	8.1	→
	3:	8.0	↘
	4:	6.6	→
	5:	7.3	→
<b>Series</b>			<b>36.0</b>
<b>Total</b>			<b>292.0</b>

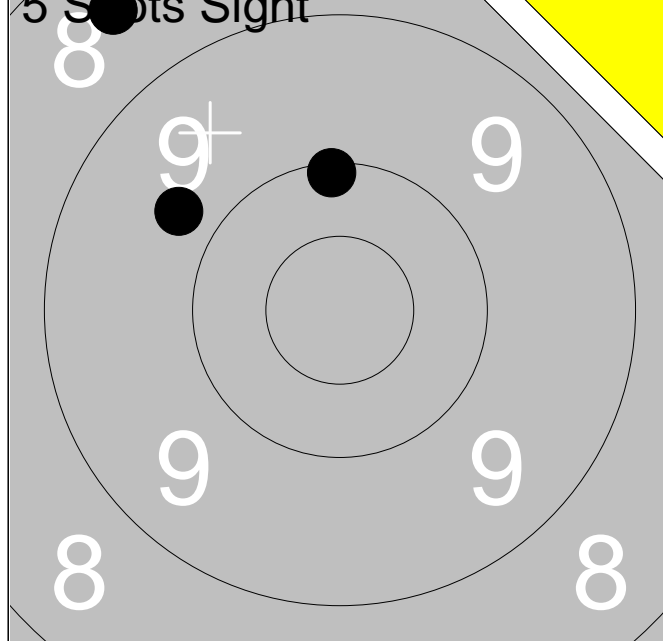

	1:	8.5			↗
	2:	10.1			↑
	3:	9.7			↘
<b>Series</b>					<b>27.0</b>
<b>Total</b>					<b>225.0</b>

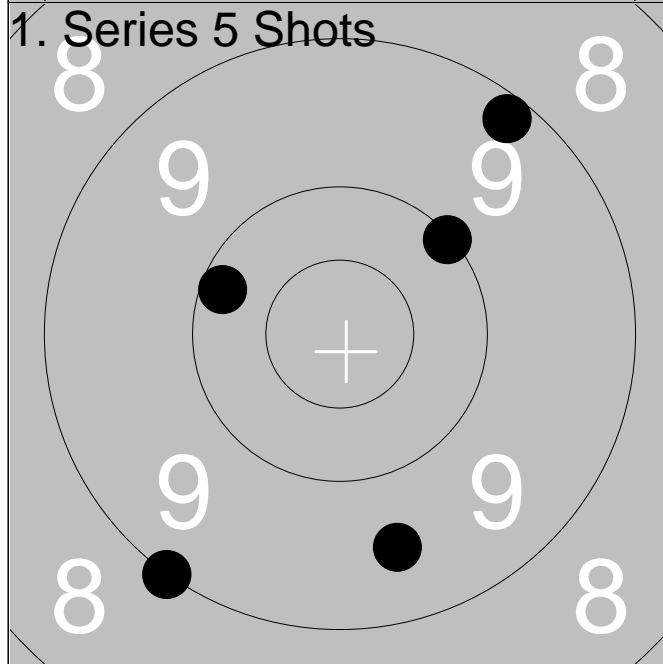

	1:	9.2			↗
	2:	9.0			↘
	3:	9.5			↓
	4:	10.1			↗
	5:	10.2			↖
<b>Series</b>					<b>47.0</b>
<b>Total</b>					<b>272.0</b>

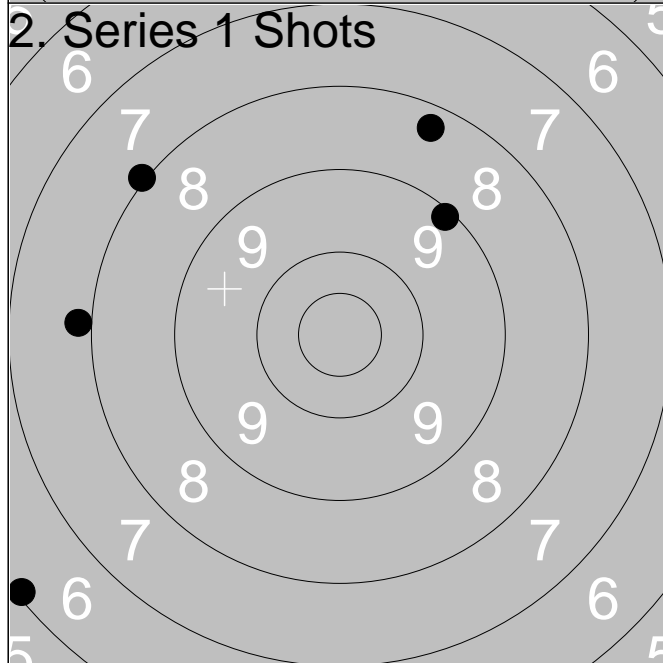

	1:	8.3			↗
	2:	7.9			↖
	3:	6.1			↘
	4:	8.0			↗
	5:	9.1			↗
<b>Series</b>					<b>38.0</b>
<b>Total</b>					<b>310.0</b>





1:	7.5	↗
2:	10.3	↘
3:	9.3	→
Series	26.0	
Total	221.0	

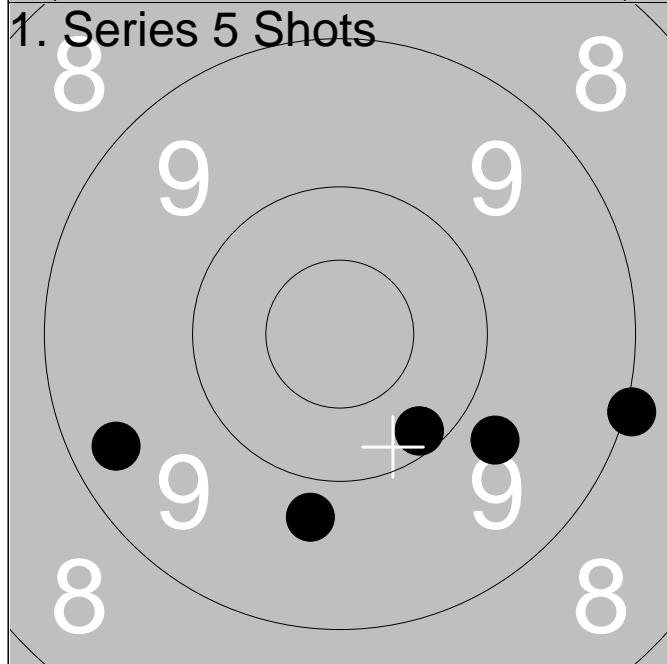

1:	9.8	↘
2:	10.2	↘
3:	9.3	↙
4:	9.0	→
5:	9.8	↘
Series	46.0	
Total	267.0	

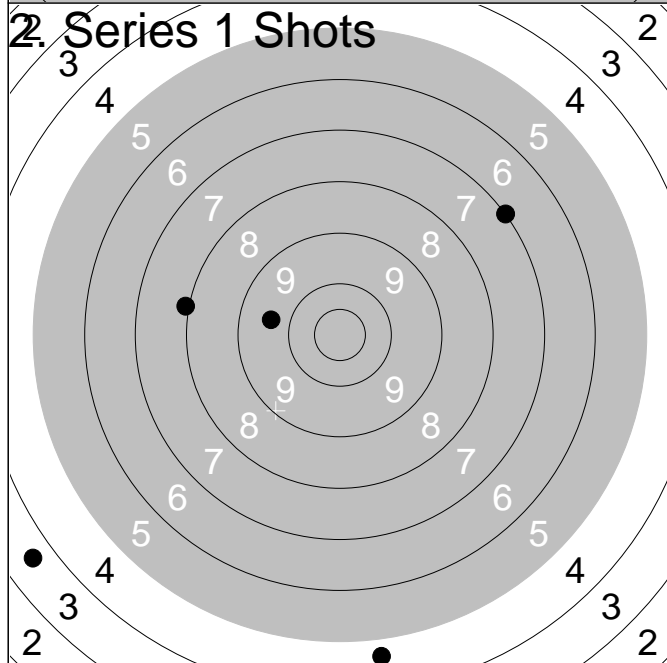

1:	4.7	↘
2:	8.0	↙
3:	3.6	↙
4:	7.0	↗
5:	9.6	↙
Series	31.0	
Total	298.0	



1:	7.5	↖
2:	7.3	↗
3:	8.9	↘

Series	22.0
Total	220.0

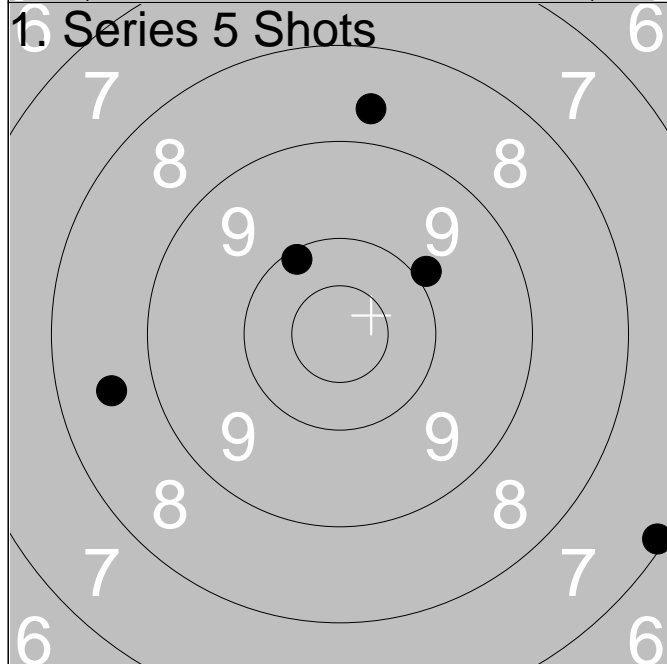

1:	8.6	←
2:	10.1	↖
3:	7.1	↘
4:	8.7	↑
5:	9.9	↗

Series	42.0
Total	262.0

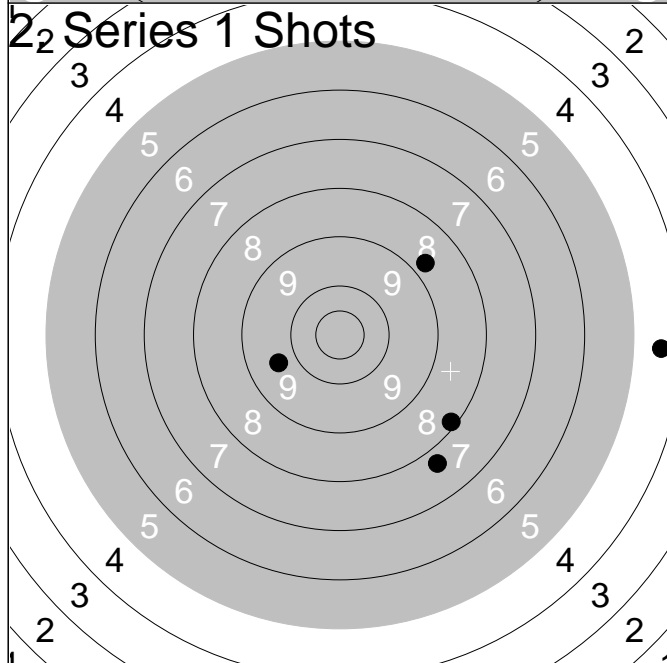

1:	8.8	↗
2:	9.7	←
3:	4.5	→
4:	8.2	↘
5:	7.7	↙

Series	36.0
Total	298.0



1:	*10.5	↘
2:	9.9	↗
3:	8.9	↗

Series	27.0
Total	218.0

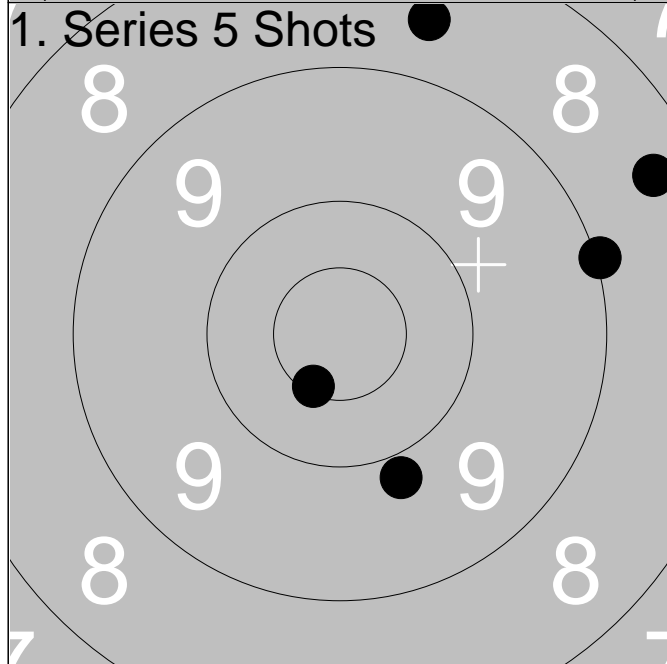

1:	*10.5	↘
2:	9.9	↘
3:	9.0	→
4:	8.6	↗
5:	8.4	→

Series	44.0
Total	262.0

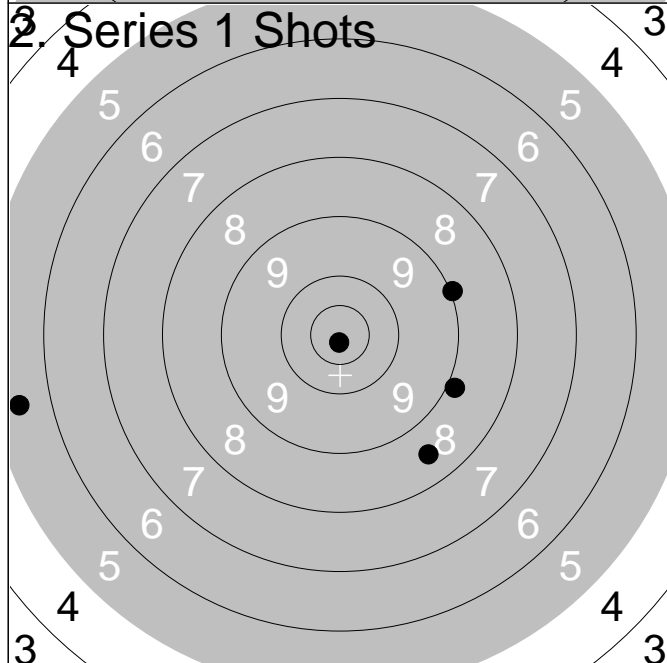

1:	5.5	←
2:	*10.8	↘
3:	8.9	→
4:	9.0	→
5:	8.5	↘

Series	40.0
Total	302.0

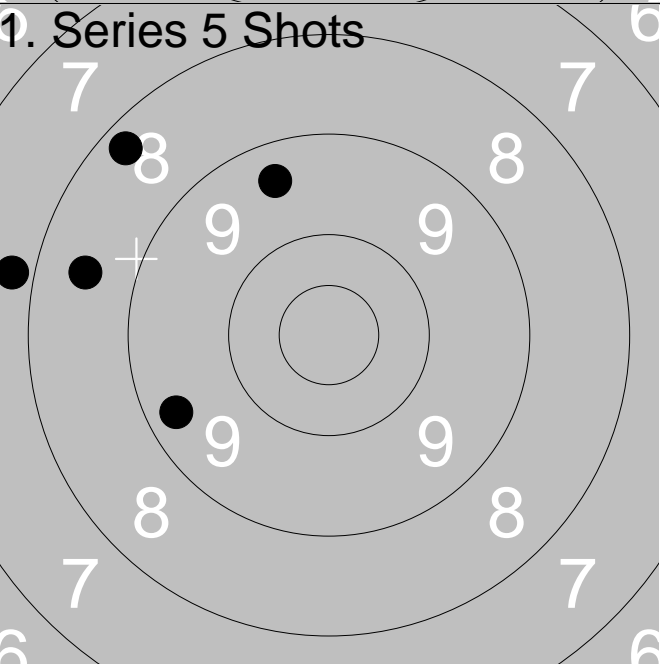
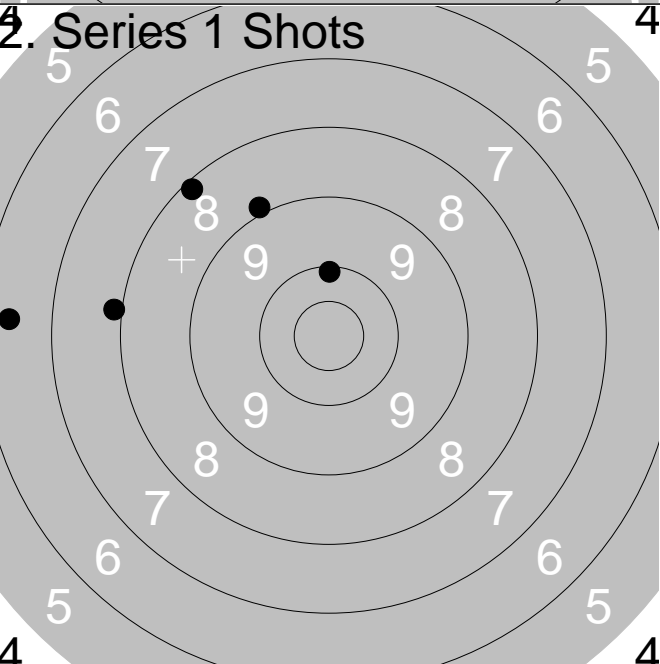
Relay <b>6</b>	Lane <b>16</b>	<b>K-A Falk</b>		
300m	I 19 / A 9	Vet	No	
2013-07-06	Björkskottet 2013	Ramselefors SKF		
<b>5 Shots Sight</b>		1:	8.5	←
		2:	8.0	←
		3:	7.3	→
		Series	23.0	
		Total	217.0	
<b>1. Series 5 Shots</b>		1:	9.3	←
		2:	7.8	←
		3:	9.4	↑
		4:	8.5	←
		5:	8.3	↗
		Series	41.0	
		Total	258.0	
<b>2. Series 1 Shots</b>		1:	8.9	↖
		2:	10.1	↑
		3:	8.1	↖
		4:	7.9	←
		5:	6.4	←
		Series	39.0	
		Total	297.0	

Relay	Lane	Johnny Wallberg		
6	18			

300m	Loos	Vet	Gä
------	------	-----	----

2013-07-06	Björskottet 2013	Ramselefors SKF
------------	------------------	-----------------



1:	7.9	↙
2:	9.8	↖
3:	9.1	↘

Series	25.0
Total	217.0

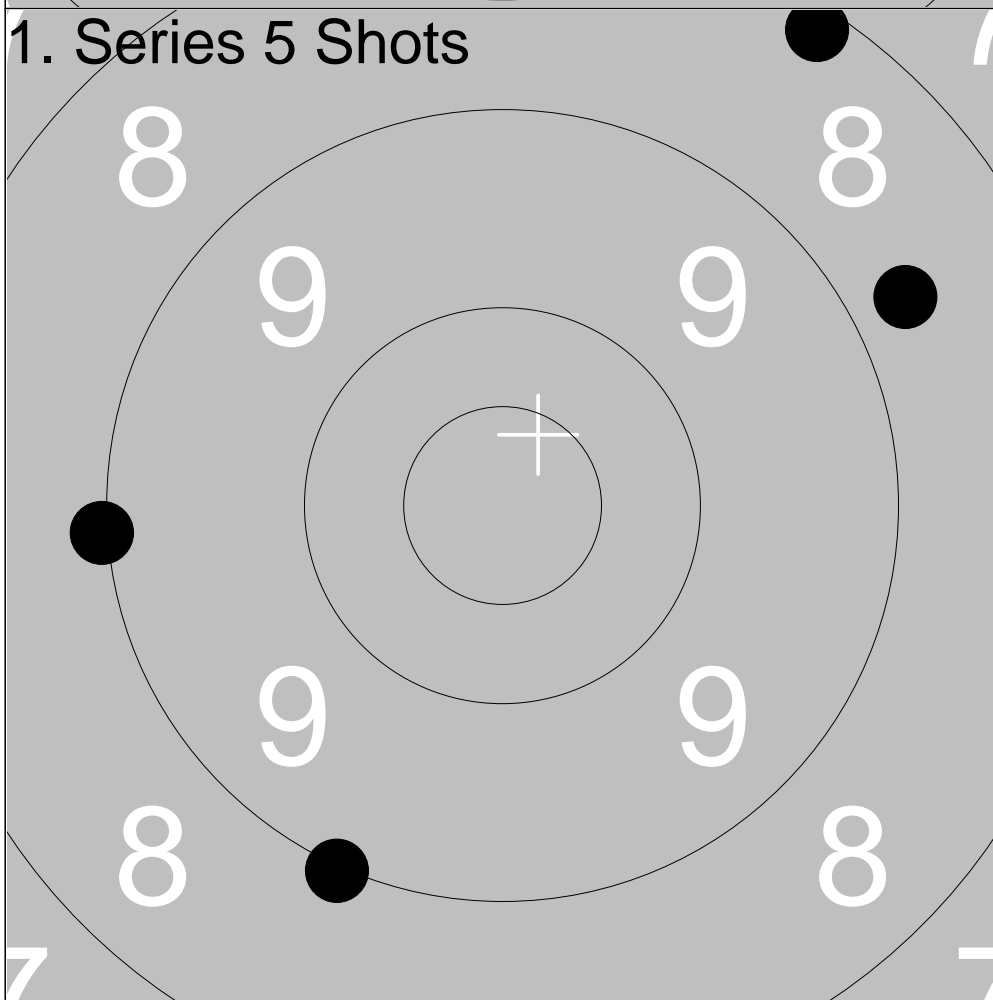

1:	8.2	↗
2:	8.7	↘
3:	9.0	↘
4:	9.0	←

Series	34.0
Total	251.0



1:	10.1	←
2:	8.0	→
3:	10.0	→
<b>Series</b>		<b>28.0</b>
<b>Total</b>		<b>216.0</b>

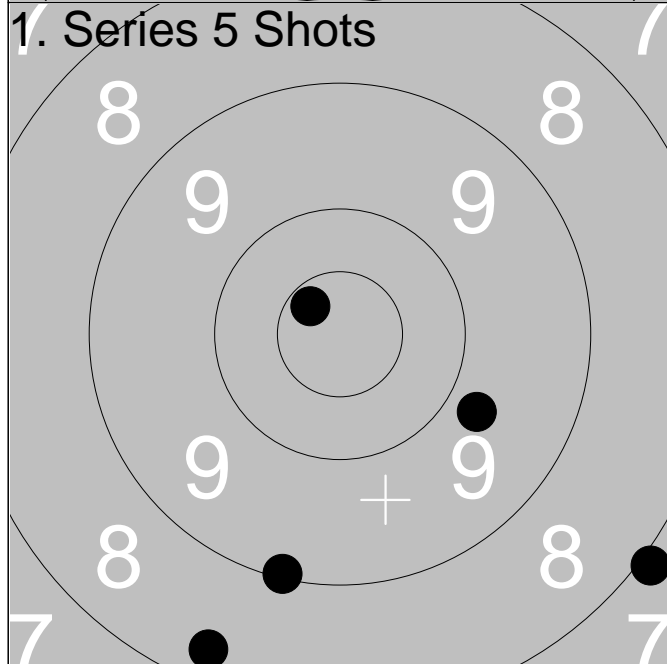

1:	7.9	↘
2:	*10.6	↗
3:	9.1	↘
4:	8.3	↘
5:	9.8	↘
<b>Series</b>		<b>43.0</b>
<b>Total</b>		<b>259.0</b>

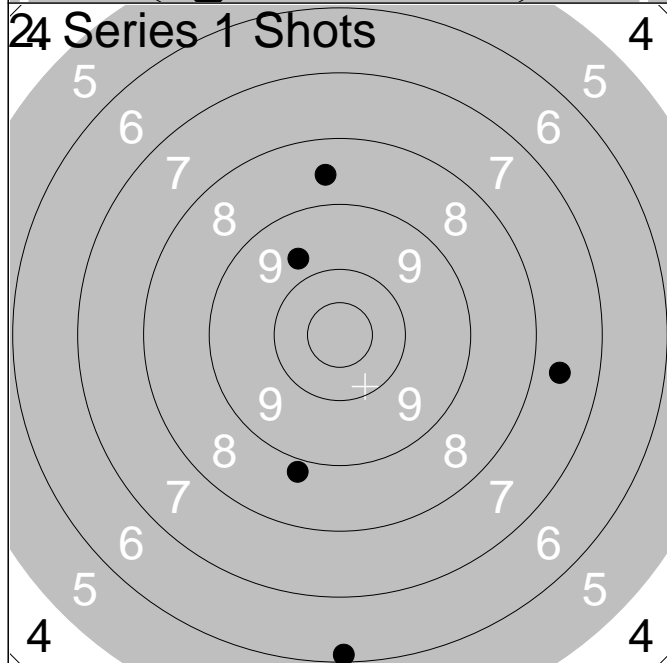

1:	6.1	↓
2:	9.7	↗
3:	7.6	→
4:	8.6	↑
5:	8.8	↘
<b>Series</b>		<b>38.0</b>
<b>Total</b>		<b>297.0</b>

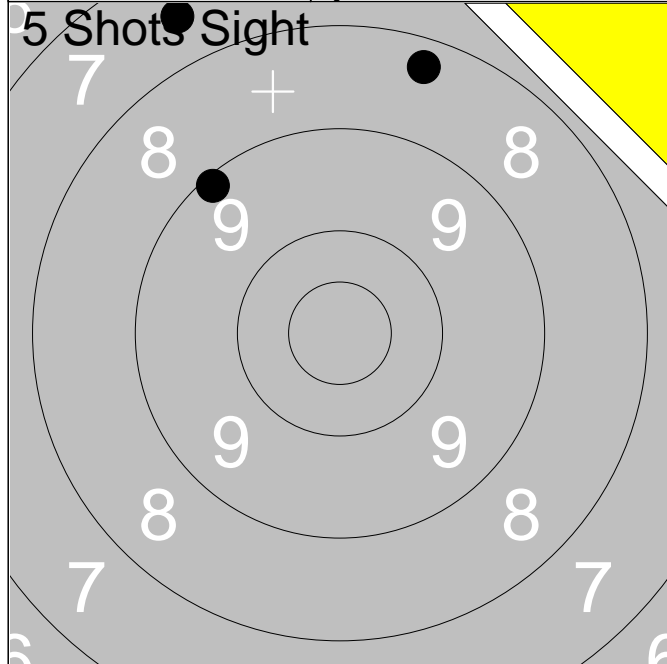

1:	9.1	↖
2:	7.6	↖
3:	8.3	↗

Series	24.0
Total	211.0

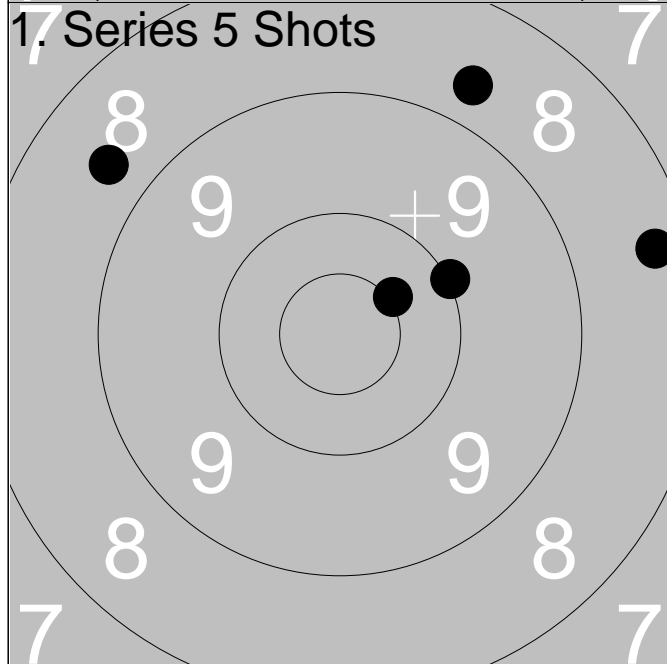

1:	8.3	→
2:	*10.5	↗
3:	8.7	↖
4:	8.7	↗
5:	10.0	↗

Series	44.0
Total	255.0

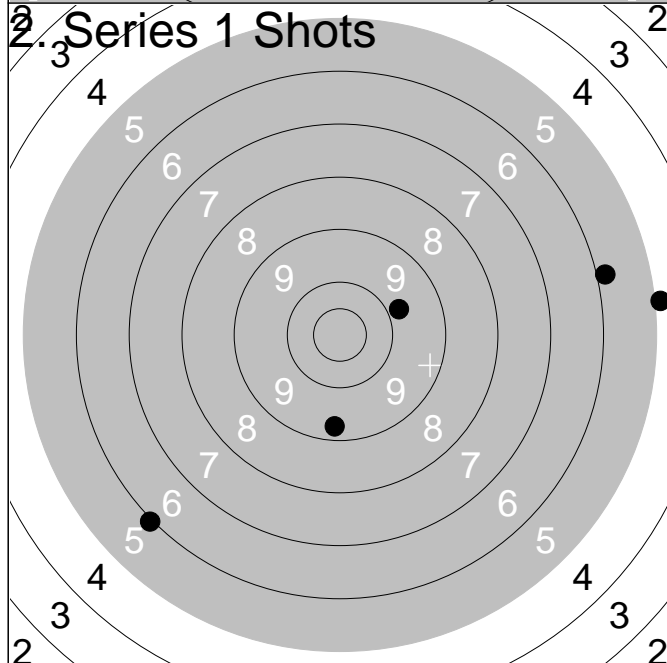

1:	5.9	→
2:	4.9	→
3:	6.0	↖
4:	9.3	↓
5:	9.8	↗

Series	33.0
Total	288.0

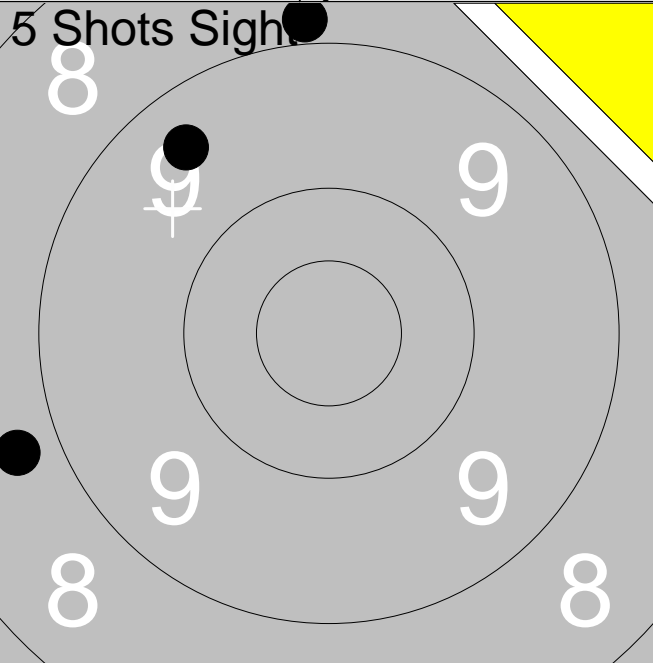
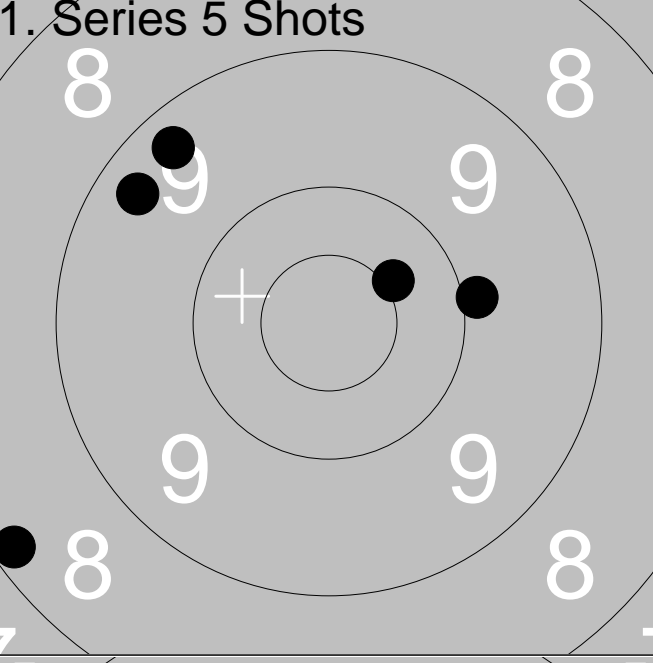
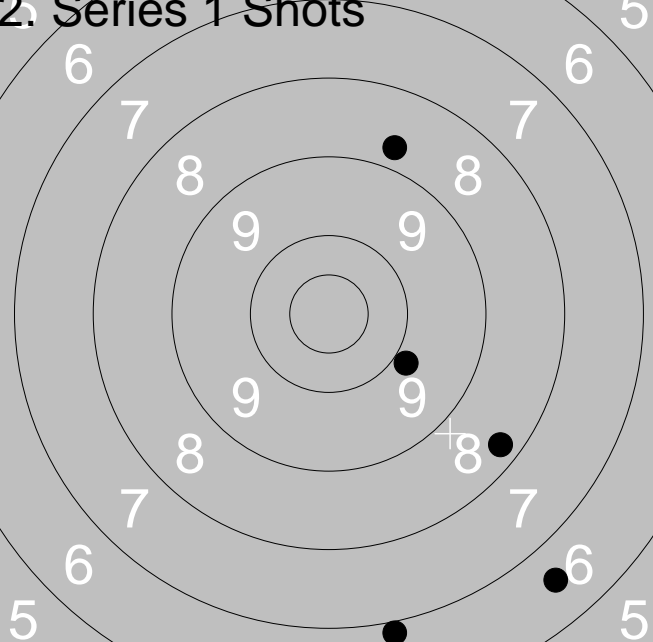
Relay <b>6</b>	Lane <b>21</b>	<b>Alf Edin</b>		
300m	Ale		Vet	No
2013-07-06	Björskottet 2013	Ramselefors SKF		
5 Shots Sight		1:	8.9	↑
		2:	9.4	↗
		3:	8.7	↙
		Series	25.0	
		Total	210.0	
1. Series 5 Shots		1:	9.3	↗
		2:	9.3	↗
		3:	9.9	→
		4:	*10.4	↗
		5:	8.2	↙
		Series	45.0	
		Total	255.0	
2. Series 1 Shots		1:	6.9	↓
		2:	6.6	↓
		3:	8.8	↗
		4:	8.3	↙
		5:	9.9	↓
		Series	37.0	
		Total	292.0	



Relay <b>6</b>	Lane <b>22</b>	<b>Tony Jansson</b>
-------------------	-------------------	---------------------

300m	Ununge	Vet	St
------	--------	-----	----

2013-07-06	Björkskottet 2013	Ramselefors SKF
------------	-------------------	-----------------



1:	8.9	↑
2:	9.4	↑
3:	9.7	↗
Series	26.0	
Total	198.0	

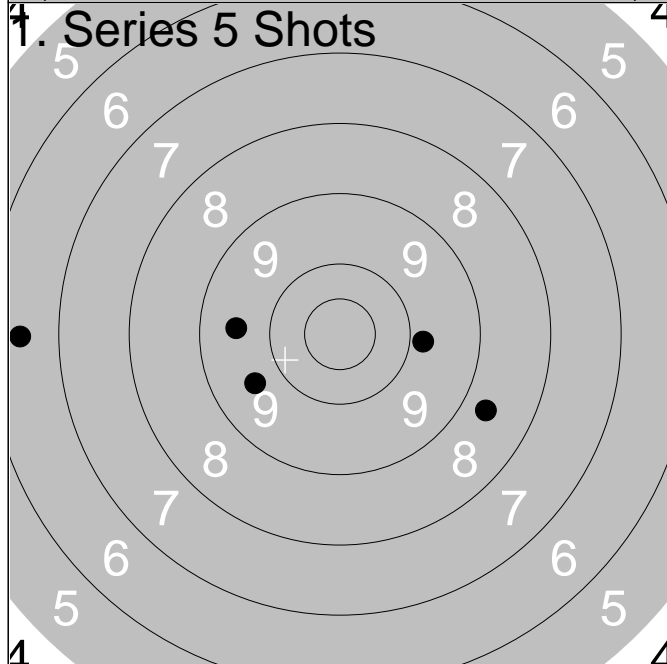

1:	9.8	→
2:	9.6	←
3:	9.6	↙
4:	6.5	←
5:	8.7	↘
Series	41.0	
Total	239.0	

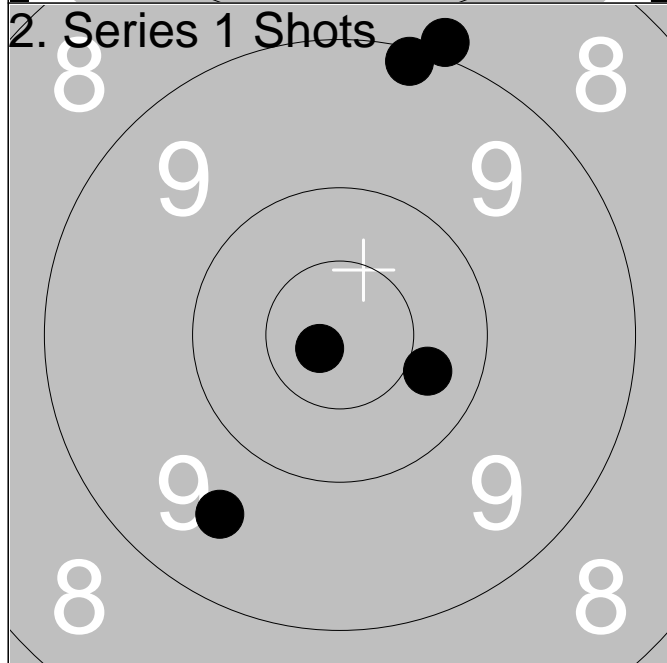

1:	9.1	↑
2:	8.9	↑
3:	9.6	↙
4:	10.4	→
5:	*10.8	↙
Series	46.0	
Total	285.0	