

1: 9.9 ↘	Series	28.0
2: 10.3 →		
3: 9.6 ↘		
Total		141.0

1: 8.5 ↗	Series	45.0
2: 10.1 ↖		
3: 9.8 ←		
4: 9.9 ↑		
5: 9.9 ↘		
Total		186.0

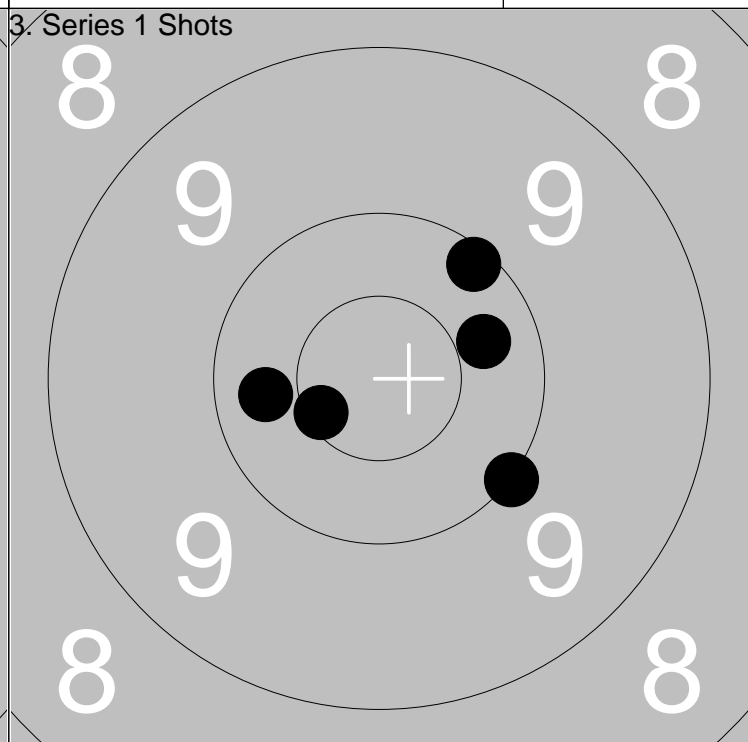
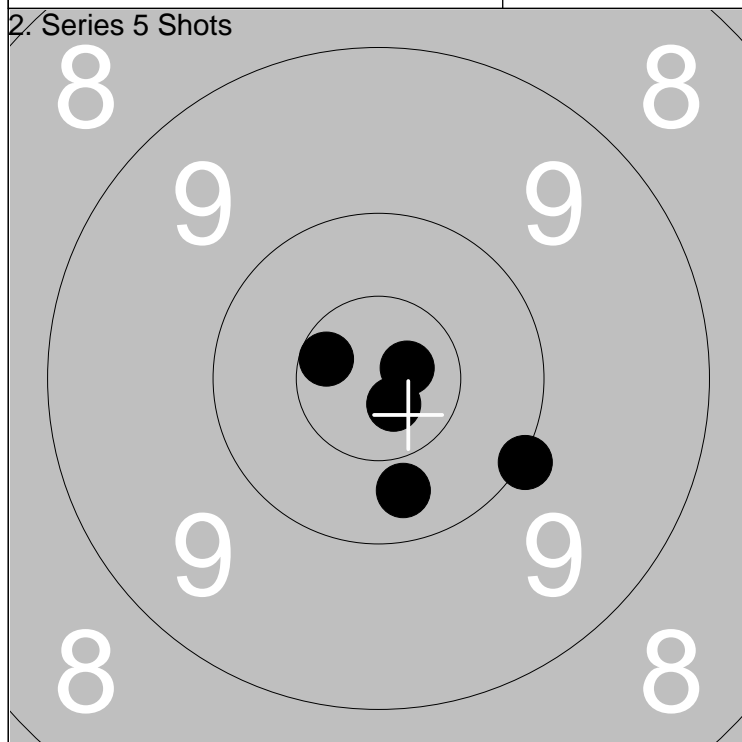

1: *10.8 ↘	Series	50.0
2: 10.0 ↘		
3: *10.8 →		
4: 10.3 ↓		
5: *10.6 ↙		
Total		236.0

1: 10.3 →	Series	50.0
2: 10.3 ←		
3: 10.0 ↘		
4: 10.1 ↗		
5: *10.6 ↙		
Total		286.0

Relay **4** Lane **2** **Nils Ström**

300m Övertorneå E No

2013-07-07 Tavelträffen A 2013 Ramselefors SKF

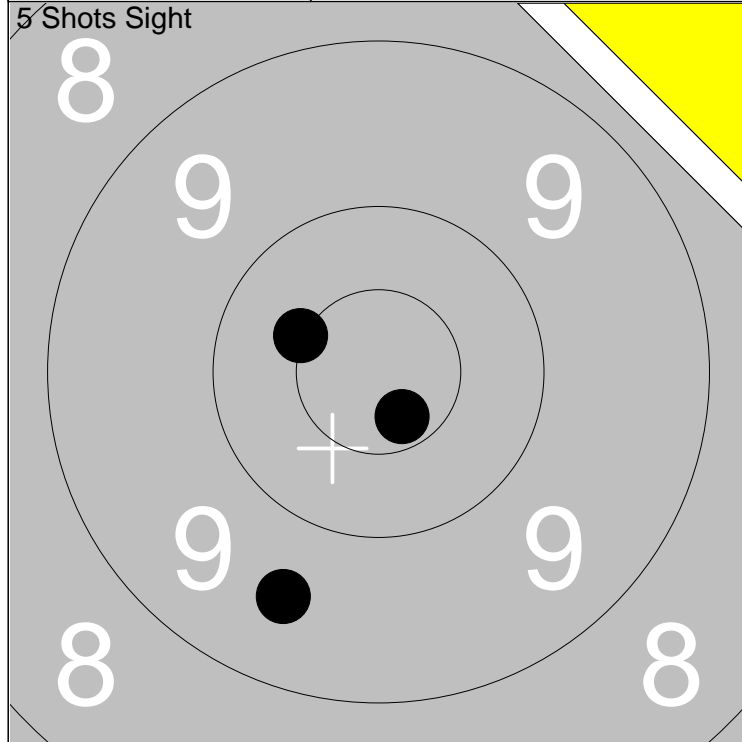

1: *10.7 ↘	Series	29.0
2: 9.6 ↘		
3: *10.5 ↙		
Total		140.0

1: 8.2 ↑	Series	46.0
2: *10.6 →		
3: 9.8 ↘		
4: 9.9 ↙		
5: 10.2 ↙		
Total		186.0

1: 8.2 ↑	Series	46.0
2: *10.6 →		
3: 9.8 ↘		
4: 9.9 ↙		
5: 10.2 ↙		
Total		186.0

1: 8.2 ↑	Series	46.0
2: *10.6 →		
3: 9.8 ↘		
4: 9.9 ↙		
5: 10.2 ↙		
Total		186.0

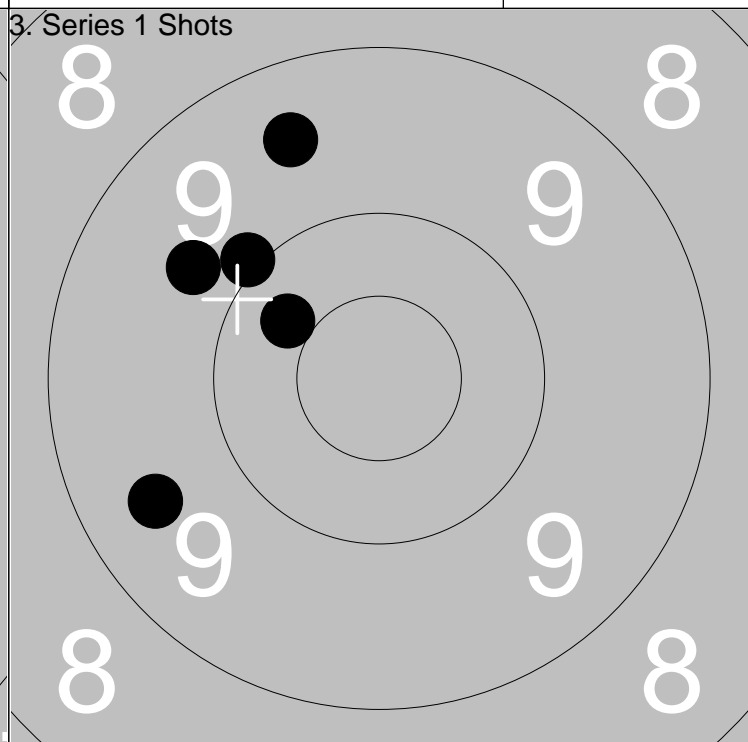
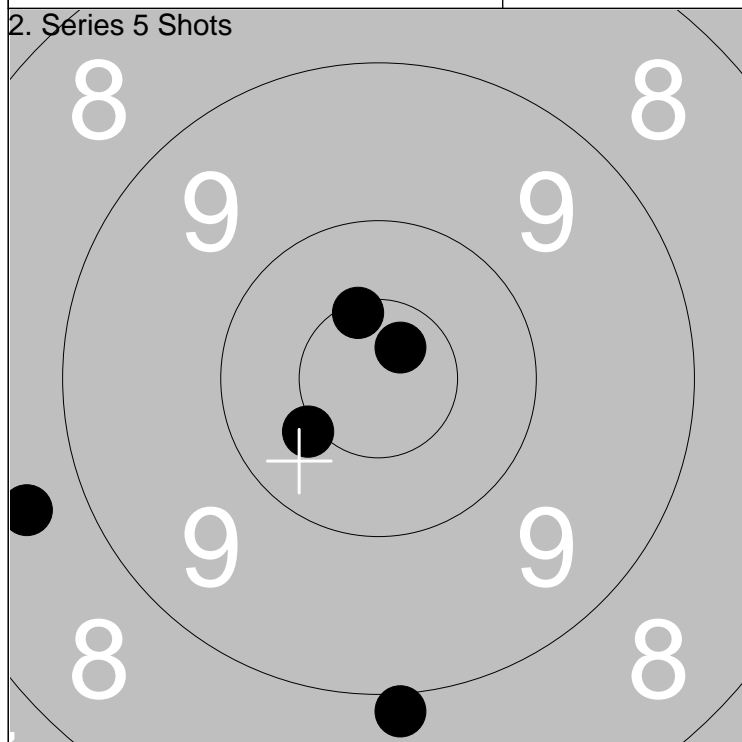

1: *10.5 ↑	Series	46.0
2: *10.7 ↗		
3: 8.9 ↓		
4: 8.7 ←		
5: *10.4 ↙		
Total		232.0

1: 9.7 ↙	Series	47.0
2: 10.3 ↙		
3: 9.5 ↑		
4: 10.0 ↙		
5: 9.5 ↙		
Total		279.0

1: 9.7 ↙	Series	47.0
2: 10.3 ↙		
3: 9.5 ↑		
4: 10.0 ↙		
5: 9.5 ↙		
Total		279.0

1: 9.7 ↙	Series	47.0
2: 10.3 ↙		
3: 9.5 ↑		
4: 10.0 ↙		
5: 9.5 ↙		
Total		279.0

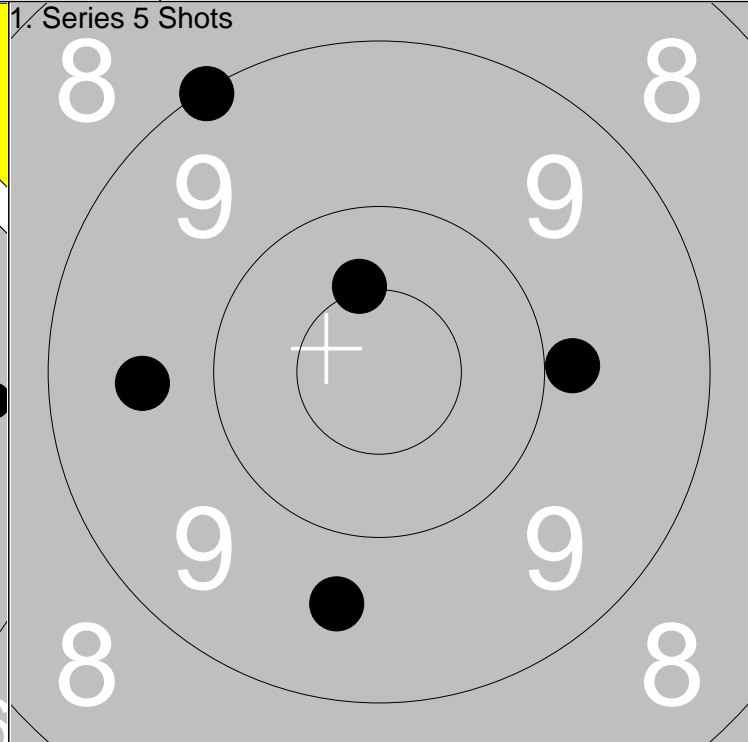
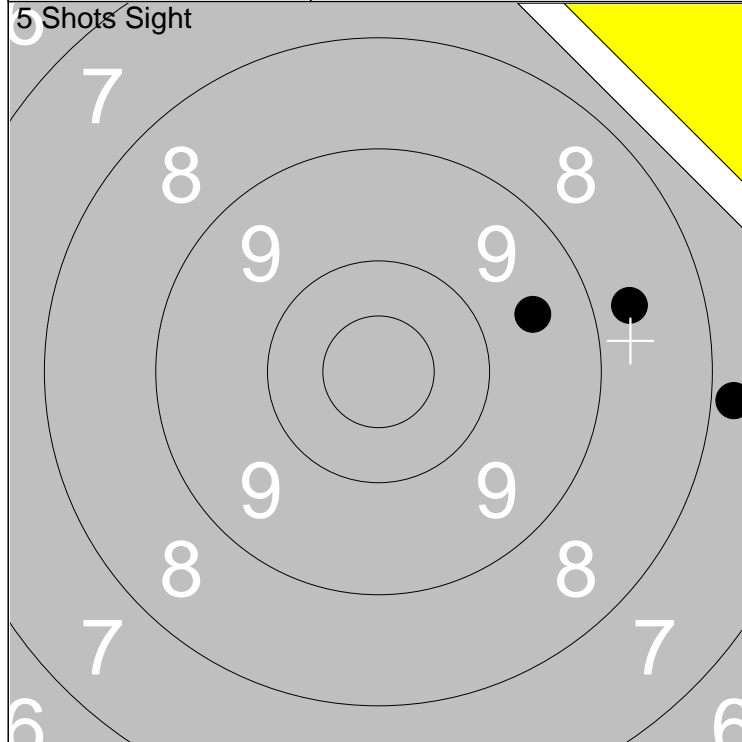

1: 7.8 →	Series	24.0
2: 9.6 →		
3: 8.7 →		
Total		137.0

1: *10.5 ↑	Series	46.0
2: 9.6 ←		
3: 9.9 →		
4: 9.1 ↖		
5: 9.6 ↓		
Total		183.0

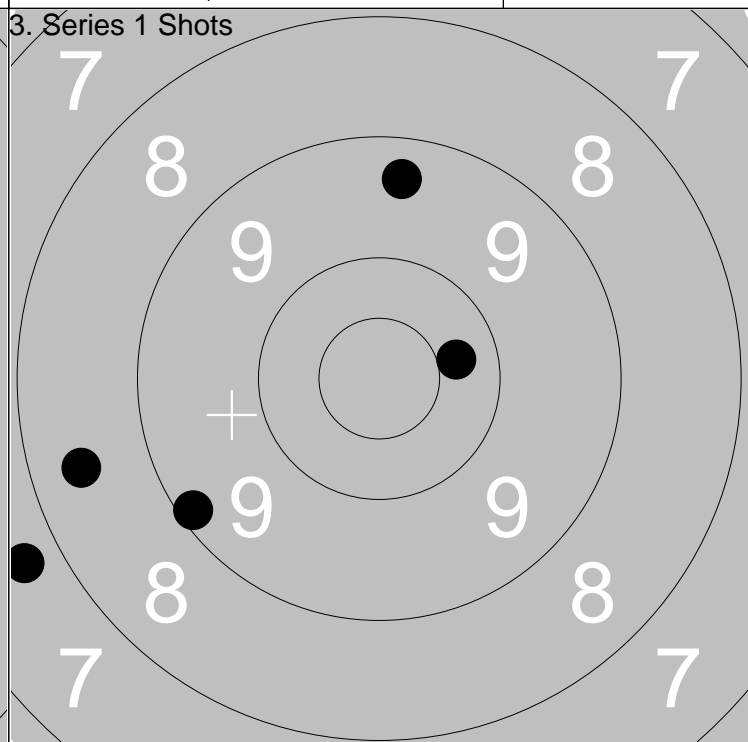
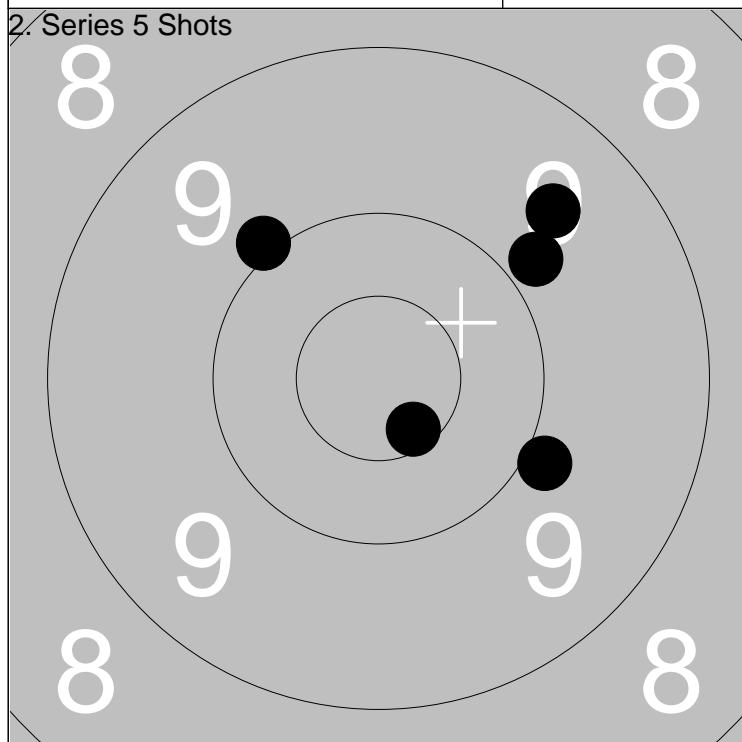

1: 9.8 ↗	Series	47.0
2: 9.6 ↗		
3: *10.6 ↘		
4: 10.0 ↖		
5: 9.9 →		
Total		230.0

1: 9.1 ↙	Series	43.0
2: 8.5 ←		
3: 10.3 →		
4: 9.4 ↑		
5: 7.7 ↙		
Total		273.0

Relay 4	Lane 4	Leif Sigfridsson		
-------------------	------------------	-------------------------	--	--

300m	Ramselefors	E	Vb
------	-------------	---	----

2013-07-07	Tavelträffen A 2013	Ramselefors SKF
------------	---------------------	-----------------

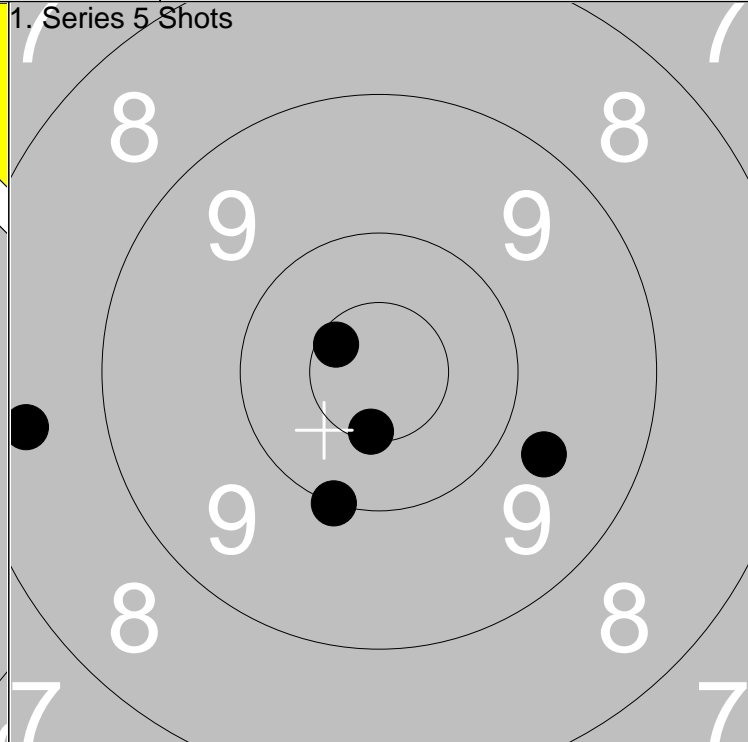
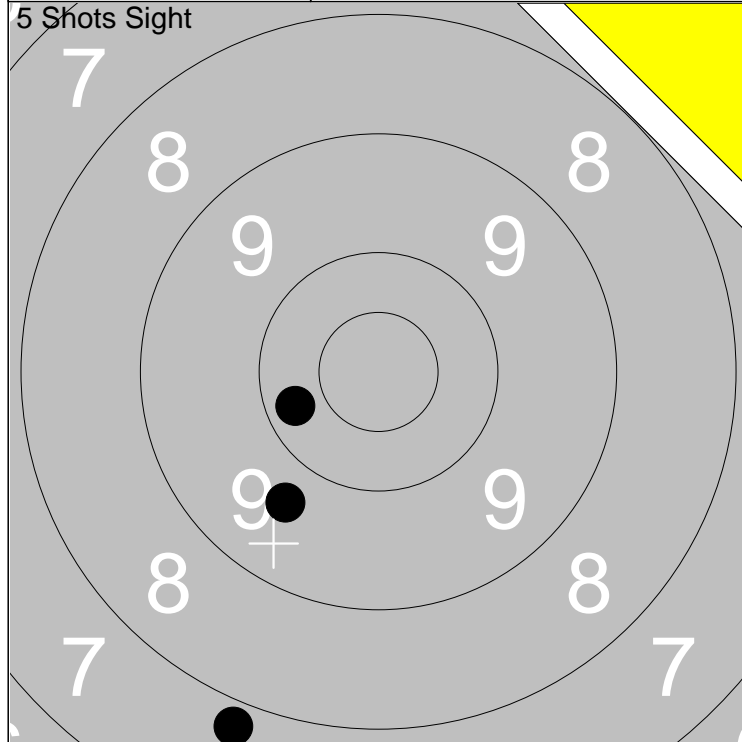

1: 10.3 ←	Series	26.0
2: 7.8 ↓		
3: 9.7 ↓		
Total		137.0

1: 8.5 ←	Series	47.0
2: 10.0 ↓		
3: 9.7 →		
Total		184.0

4: *10.5 ↓	Series	47.0
5: *10.6 ↘		
Total		

4: *10.5 ↓	Series	47.0
5: *10.6 ↘		
Total		

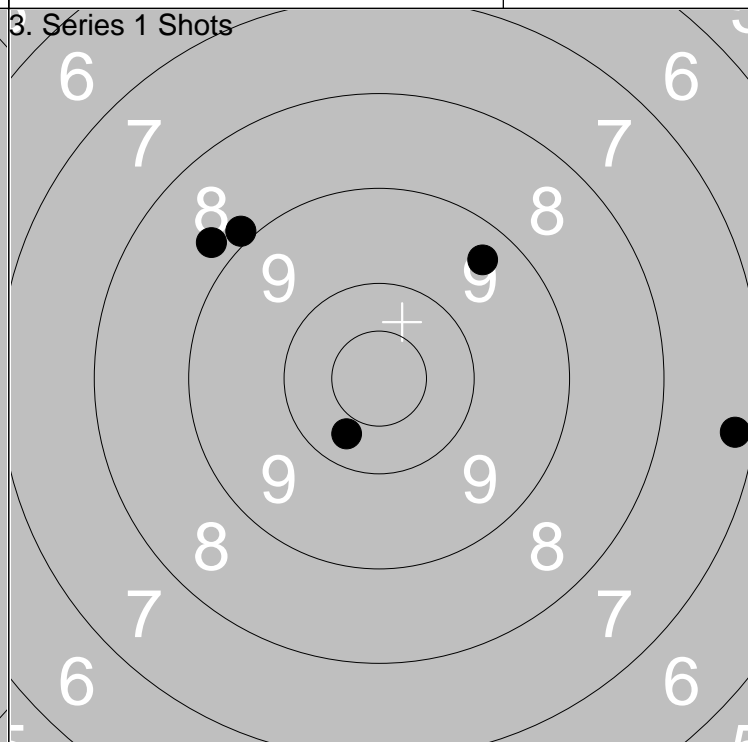
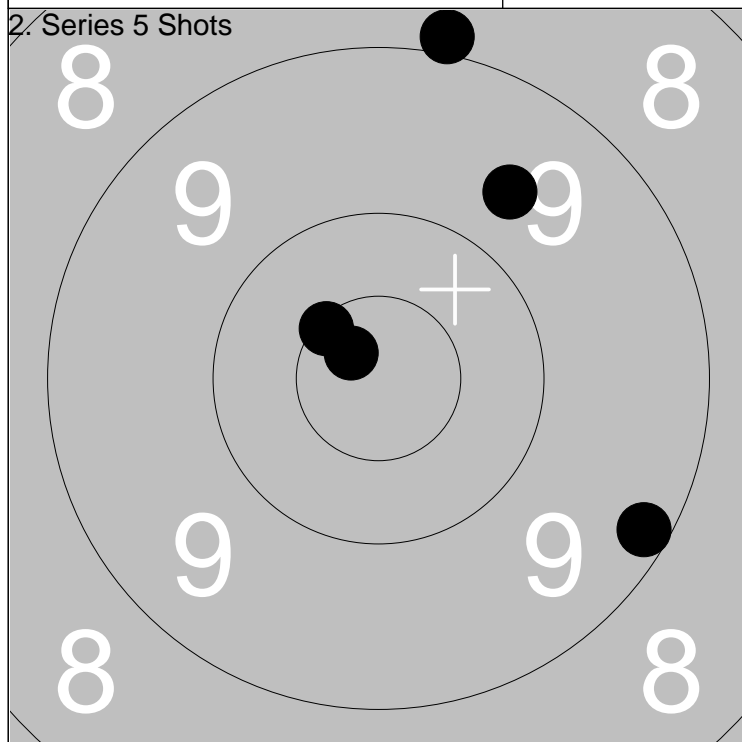

1: 9.6 ↗	Series	46.0
2: *10.7 ↘		
3: 8.9 ↑		
Total		230.0

1: 10.3 ↓	Series	42.0
2: 8.9 ↗		
3: 7.2 →		
Total		272.0

4: 8.8 ↗	Series	42.0
5: 9.4 ↗		
Total		

4: 8.8 ↗	Series	42.0
5: 9.4 ↗		
Total		

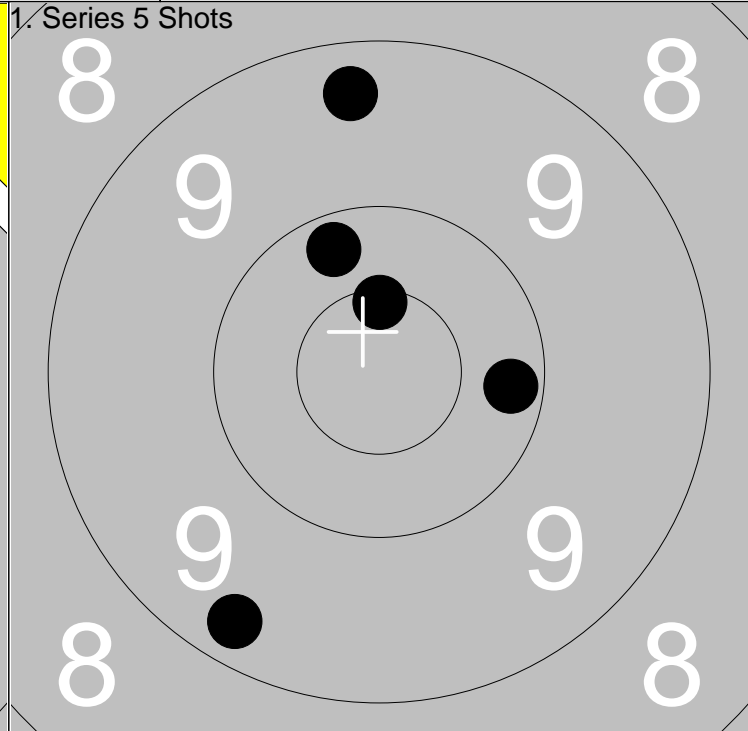
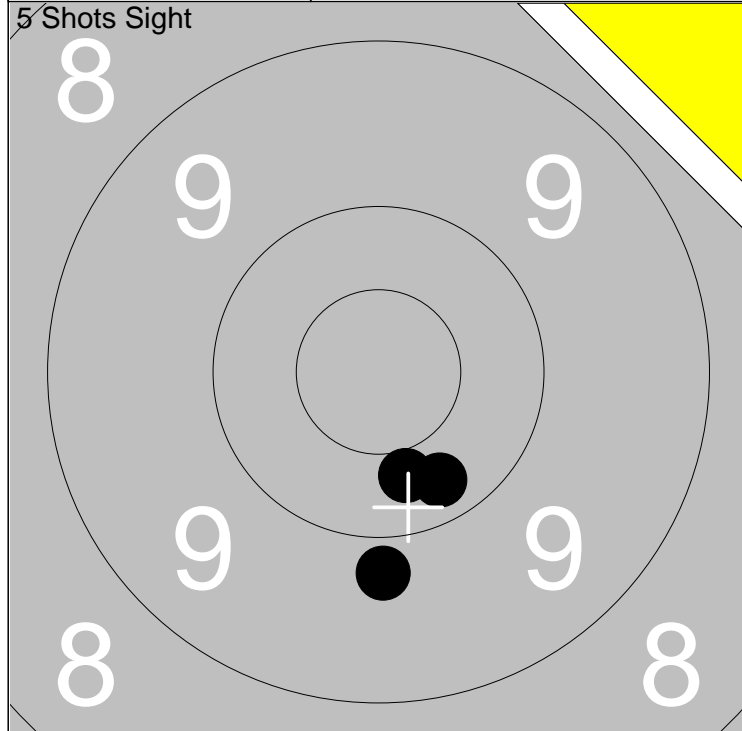

1: 9.8 ↓	Series	29.0
2: 10.3 ↓		
3: 10.3 ↓		
Total		136.0

1: 9.3 ↙	Series	48.0
2: *10.6 ↑		
3: 10.2 →		
Total		184.0

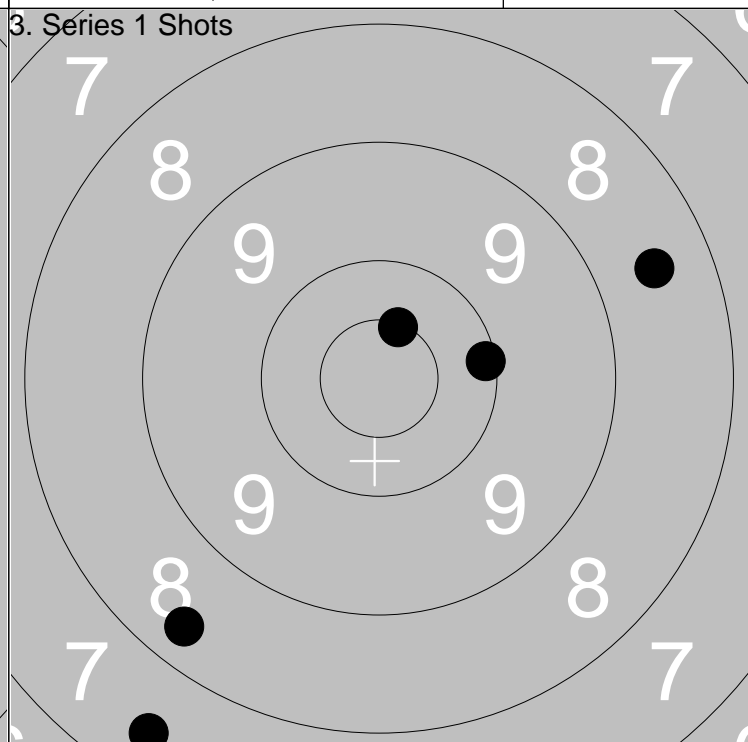
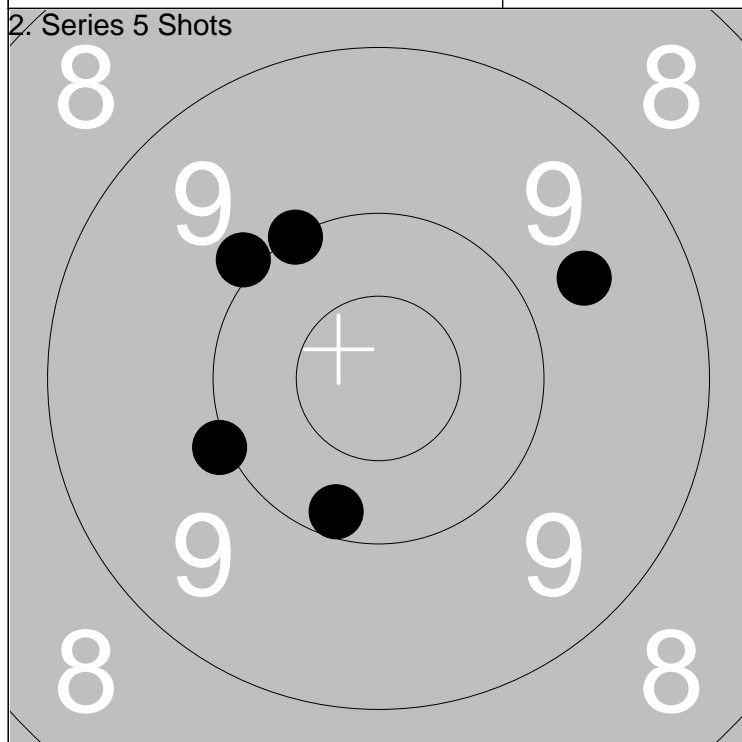

1: 10.2 ↓	Series	48.0
2: 9.9 ↖		
3: 10.0 ↖		
Total		232.0

1: 10.1 →	Series	43.0
2: 7.5 ↓		
3: 8.5 →		
Total		275.0

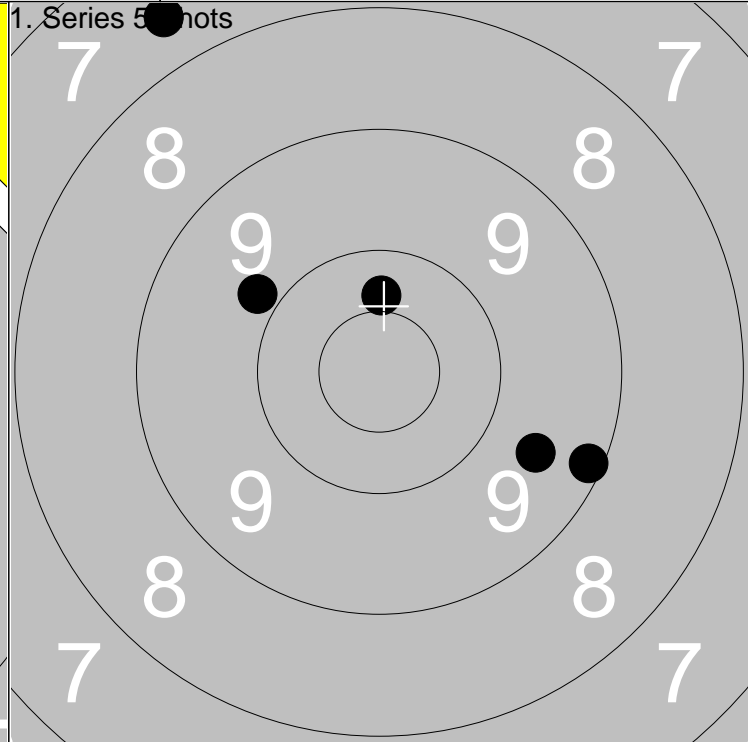
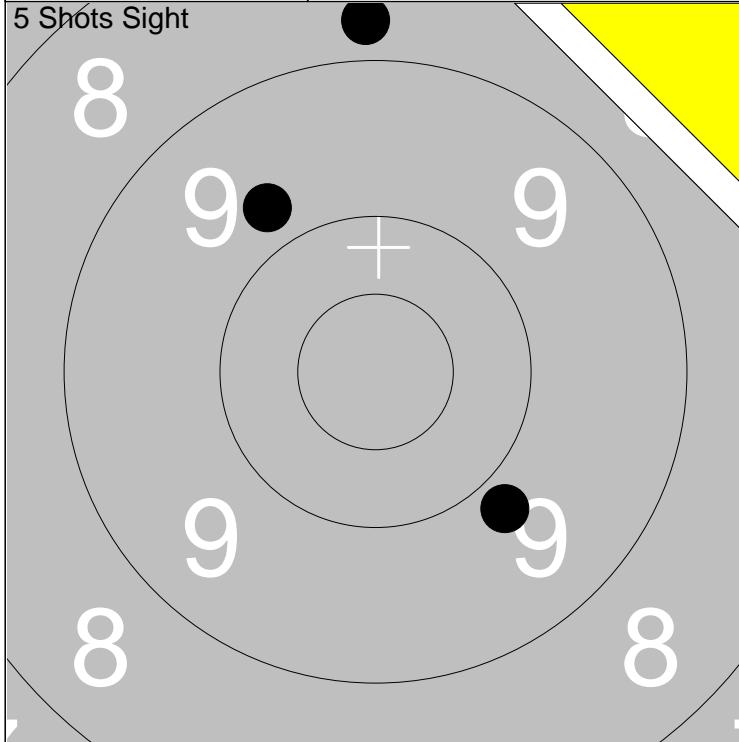

1: 9.8 ↗	Series 26.0
2: 8.8 ↑	
3: 9.8 ↘	
Total 136.0	

1: 9.6 ➡	Series 44.0
2: 9.8 ↗	
3: 10.4 ↑	
Total 180.0	

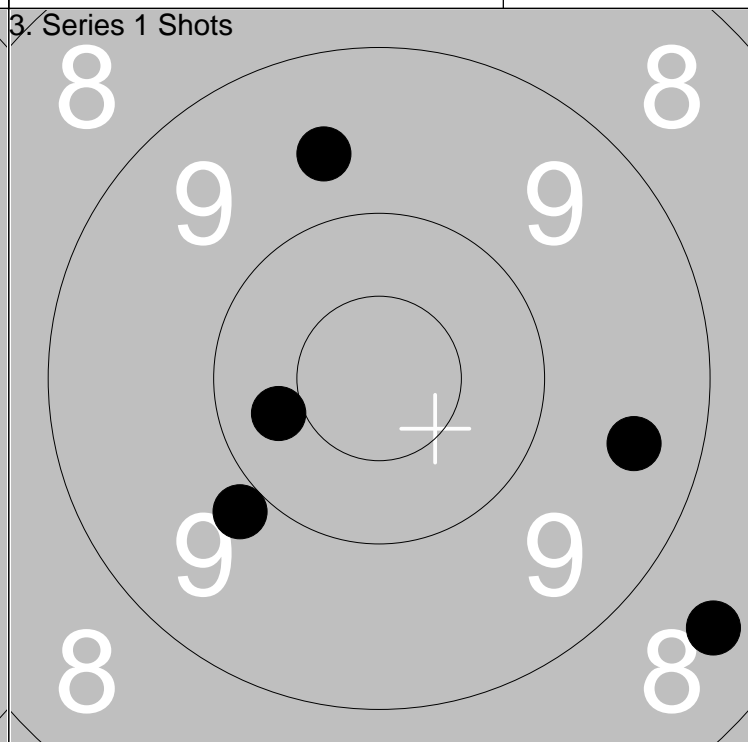
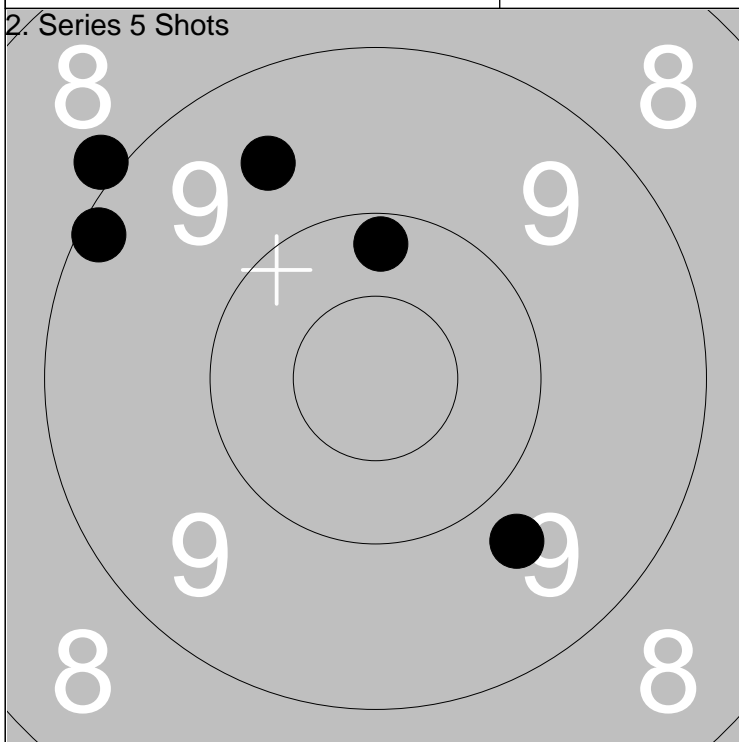

1: 9.7 ↘	Series 45.0
2: 9.1 ↗	
3: 10.2 ↑	
Total 225.0	

1: 9.6 ↑	Series 45.0
2: 10.4 ←	
3: 8.5 ↘	
Total 270.0	

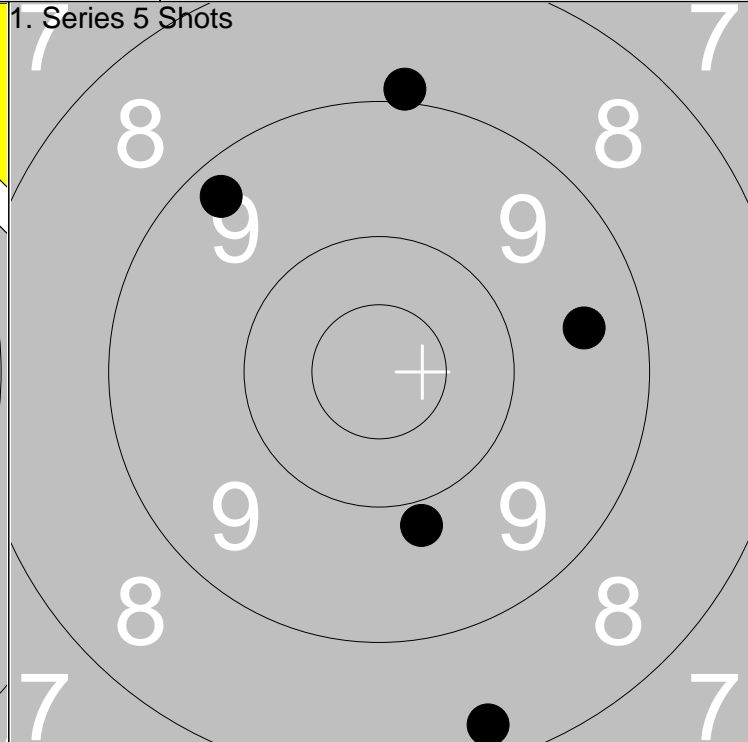
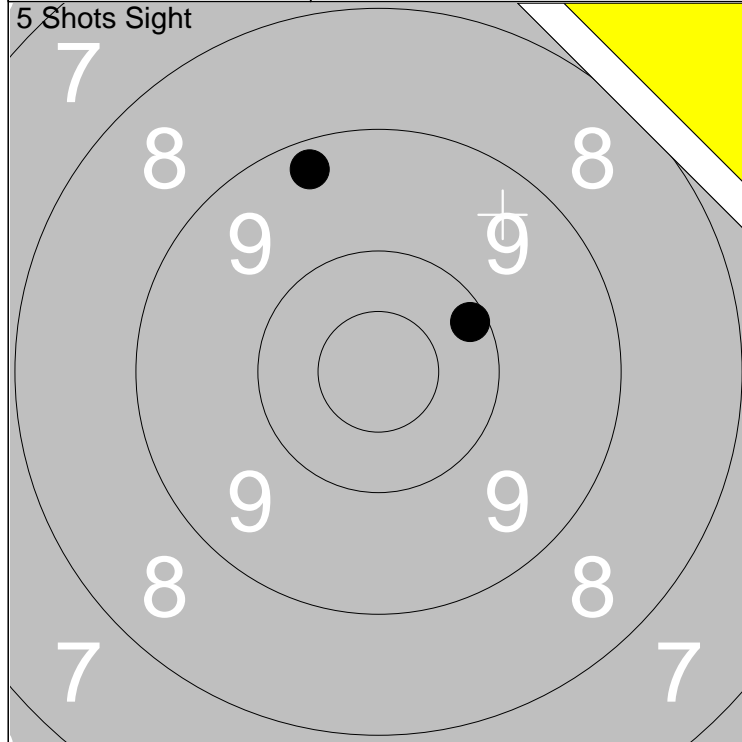

1: 9.3 ↑	Series	26.0
2: 7.6 ↗		
3: 10.2 ↗		
Total		130.0

1: 8.9 ↑	Series	43.0
2: 9.3 ↖		
3: 9.9 ↓		
4: 9.5 →		
5: 8.3 ↓		
Total		173.0

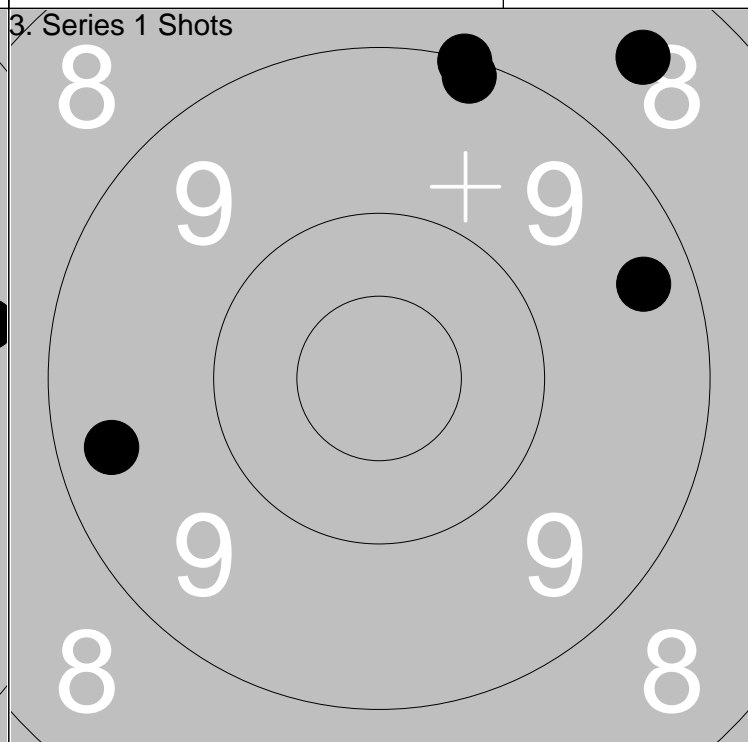
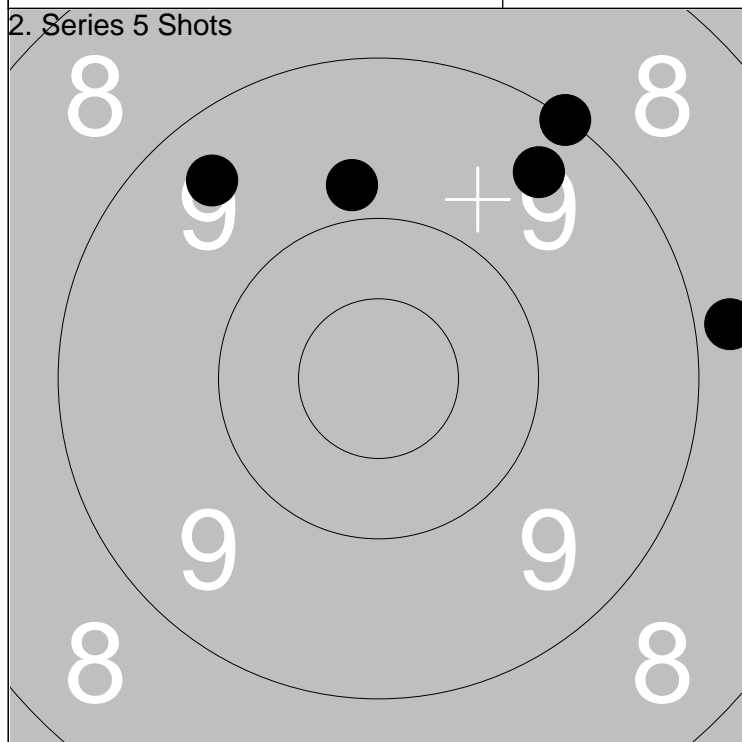

1: 8.8 →	Series	44.0
2: 9.8 ↑		
3: 9.0 ↗		
4: 9.4 ↖		
5: 9.4 ↗		
Total		217.0

1: 8.5 ↗	Series	44.0
2: 9.0 ↑		
3: 9.1 ↑		
4: 9.4 ←		
5: 9.3 →		
Total		261.0

Relay 4	Lane 8	Erik Björndahl		
-------------------	------------------	-----------------------	--	--

300m	Kvistbro	E	Ör
------	----------	---	----

2013-07-07	Tavelträffen A 2013	Ramselefors SKF
------------	---------------------	-----------------

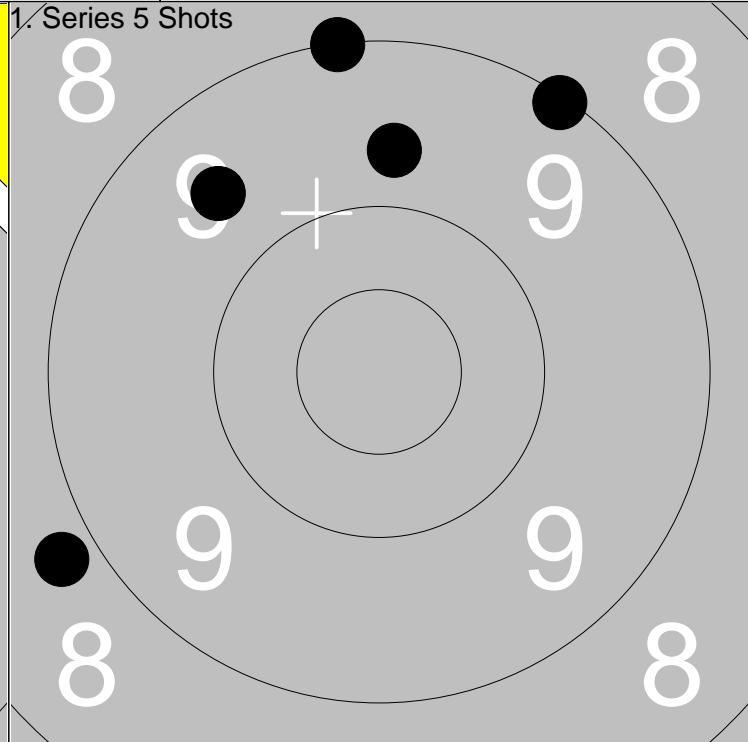
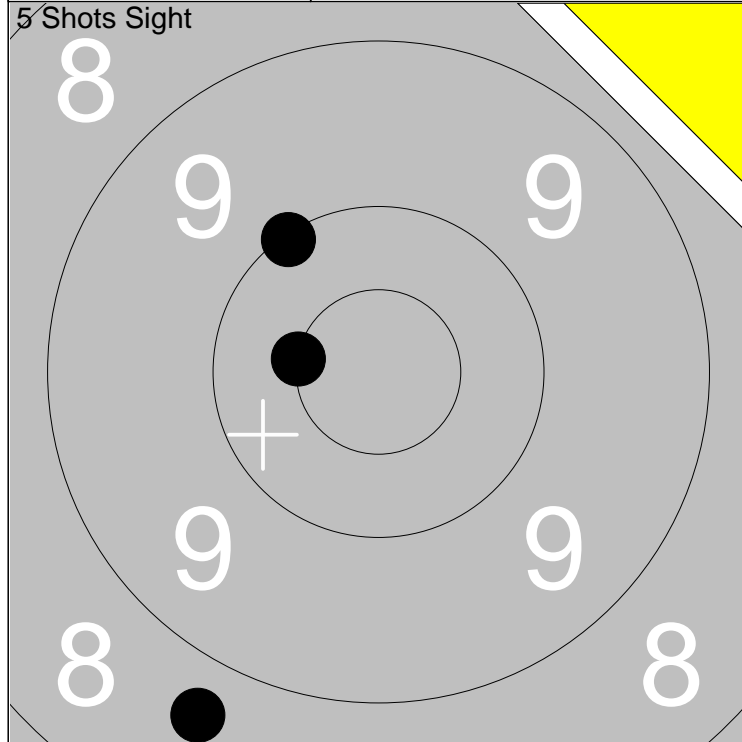

1: 8.7 ↘	Series	28.0
2: 10.1 ↖		
3: *10.5 ↖		
Total		128.0

1: 9.6 ↖	Series	44.0
2: 8.8 ↙		
3: 9.7 ↑		
4: 9.0 ↑		
5: 9.1 ↗		
Total		172.0

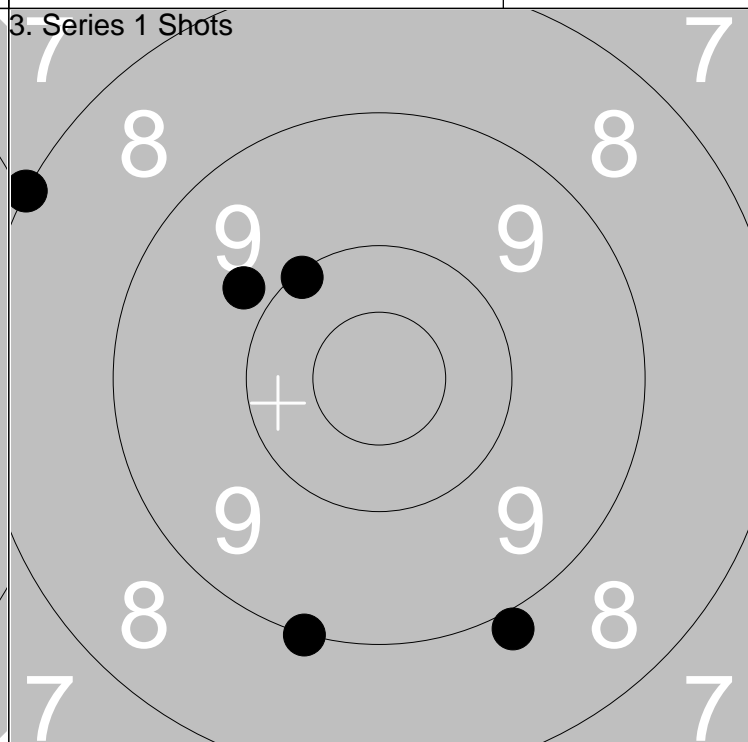
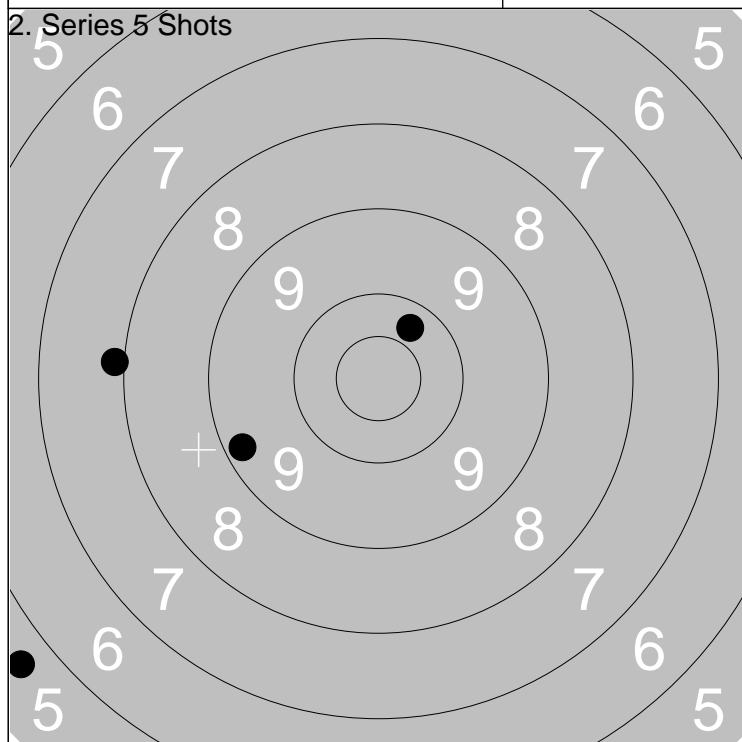

1: 10.3 ↗	Series	31.0
2: 9.2 ↙		
3: 7.9 ←		
4: 5.6 ↙		
5: 0.0		
Total		203.0

1: 10.1 ↖	Series	44.0
2: 9.8 ↖		
3: 8.0 ↖		
4: 8.9 ↘		
5: 9.0 ↘		
Total		247.0

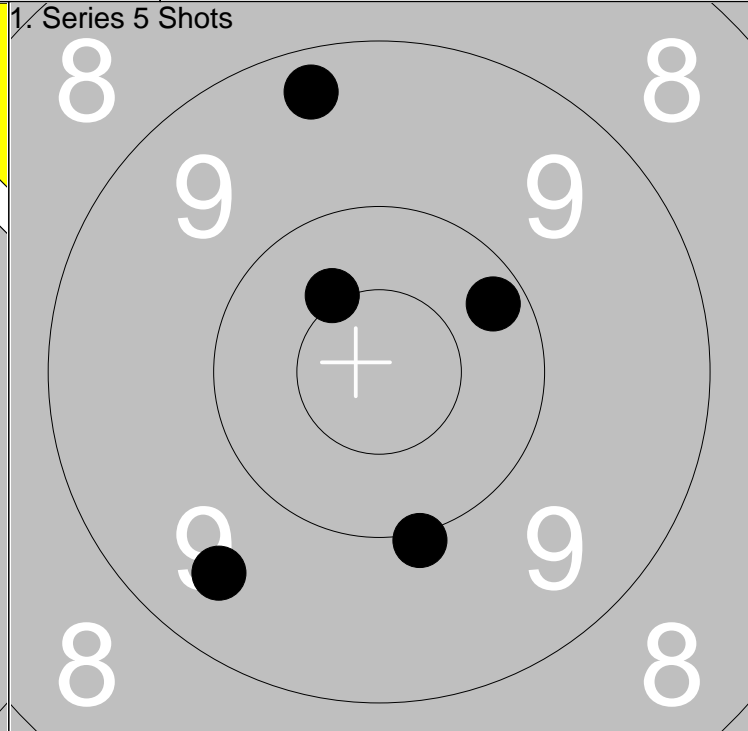
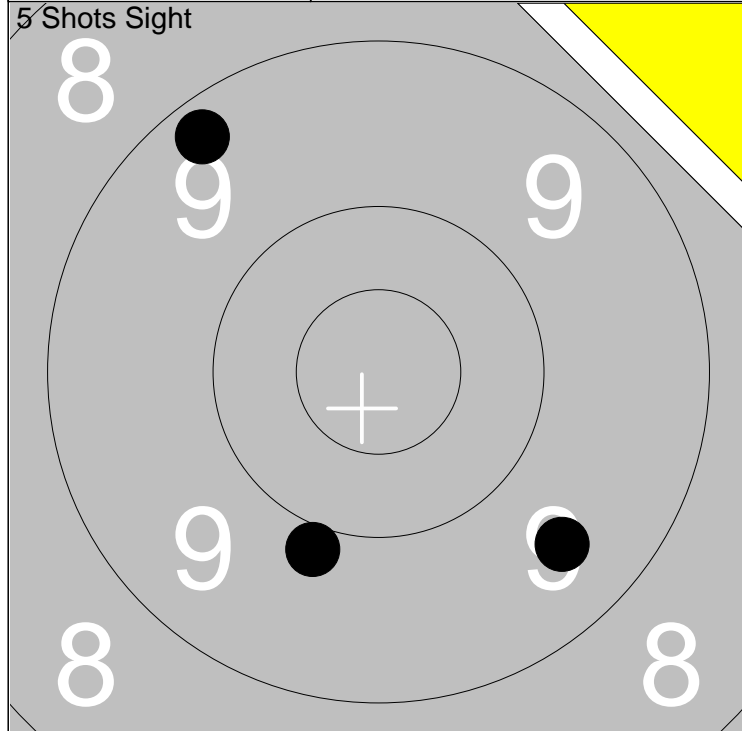

1: 9.5	↘
2: 9.9	↘
3: 9.3	↗
Series	27.0
Total	148.0

1: 9.3	↗
2: 10.2	↗
3: 9.5	↘
4: *10.5	↖
5: 10.0	↘
Series	48.0
Total	196.0

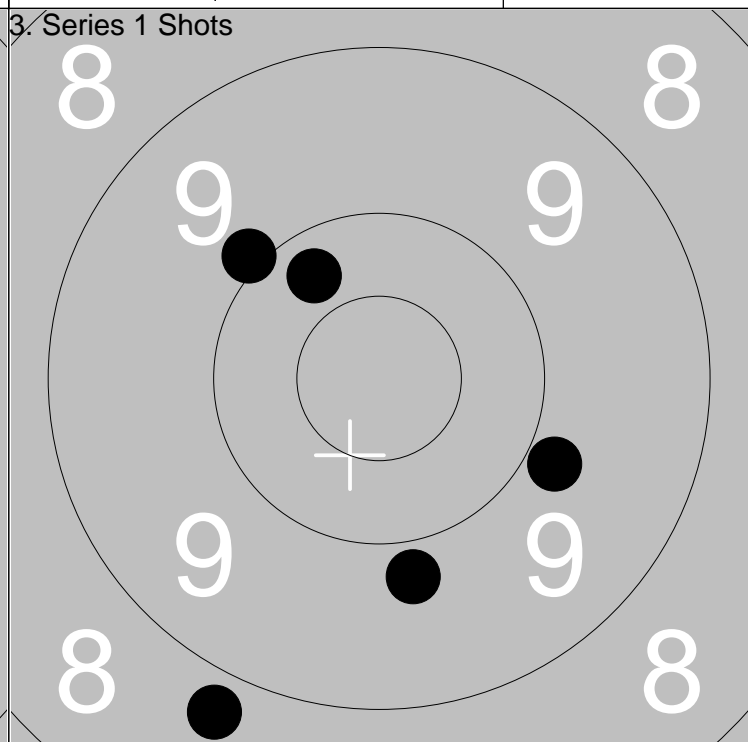
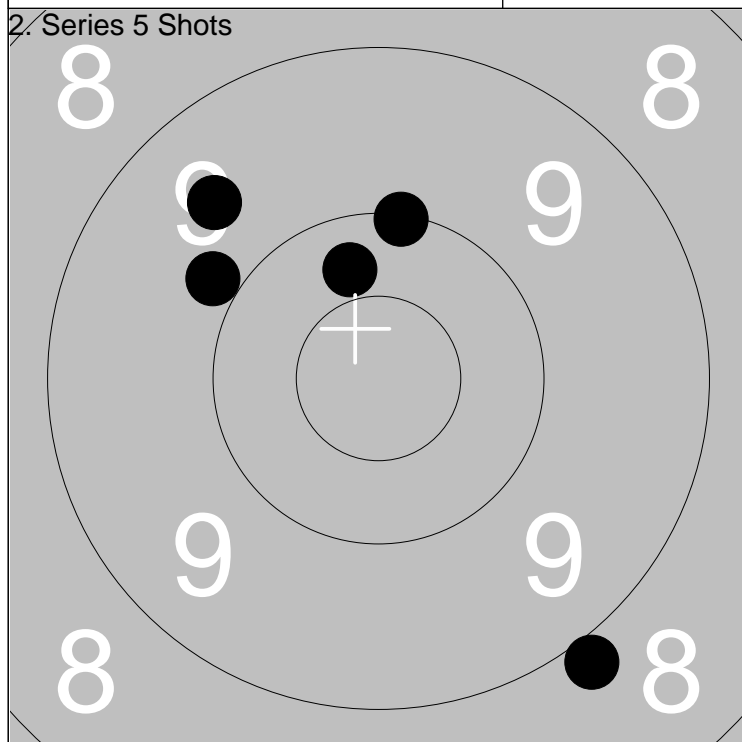

1: 8.9	↘
2: 9.6	↗
3: 9.9	↗
4: 10.0	↗
5: 10.3	↗
Series	46.0
Total	242.0

1: 8.8	↘
2: 9.8	↘
3: 9.8	↗
4: 10.3	↗
5: 9.9	↗
Series	45.0
Total	287.0

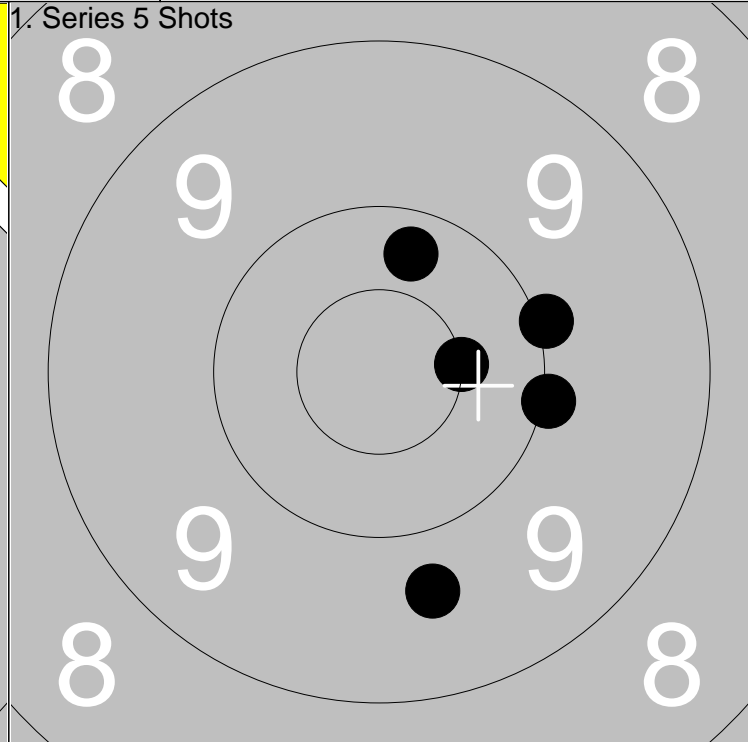
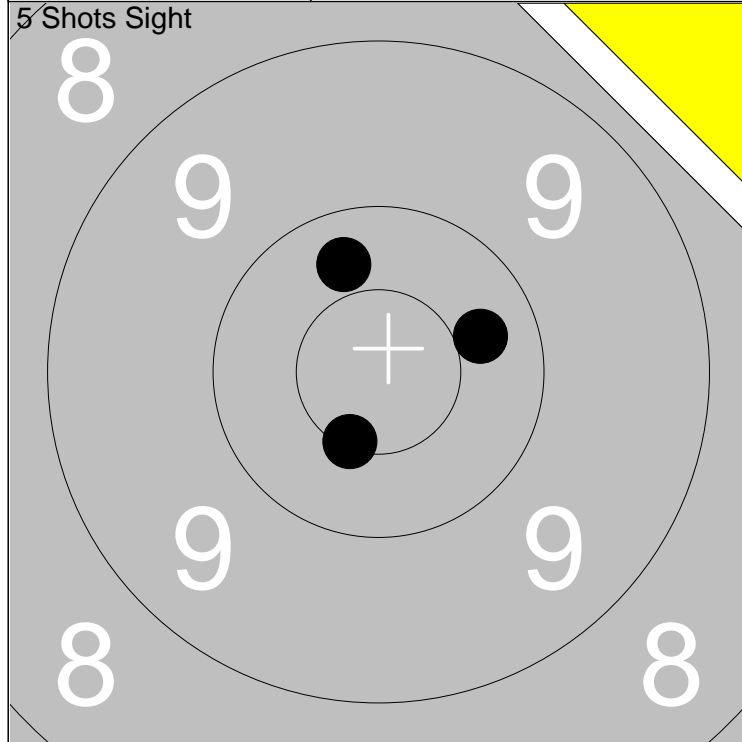

1: 10.3 →	Series 30.0
2: 10.3 ↑	
3: *10.5 ↓	
Total 147.0	

1: *10.5 →	Series 49.0
2: 10.3 ↑	
3: 10.0 →	
Total 196.0	

4: 9.7 ↓	Series 47.0
5: 10.0 →	
Total 292.0	

1: *10.7 ↙	Series 49.0
2: 10.1 ↗	
3: 9.6 ↑	
Total 245.0	

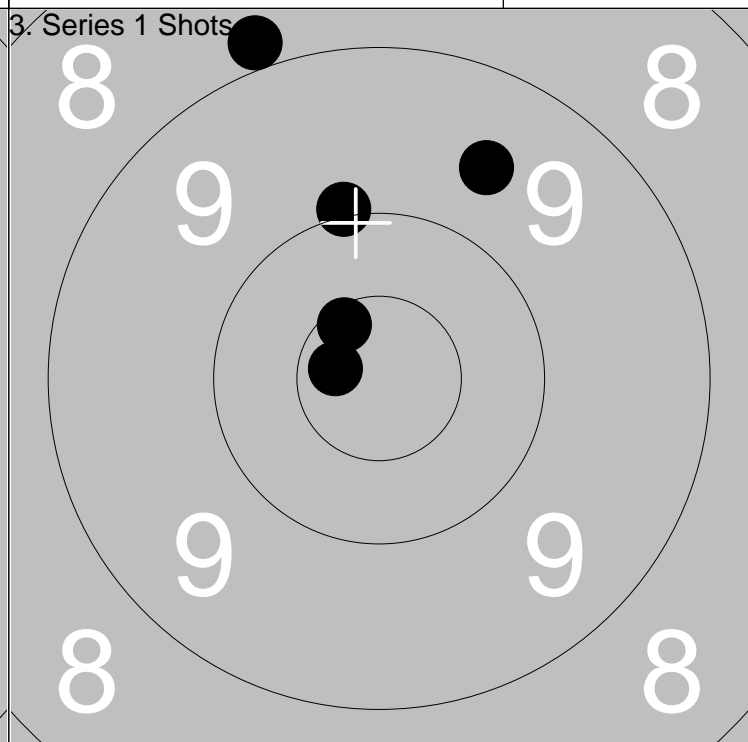
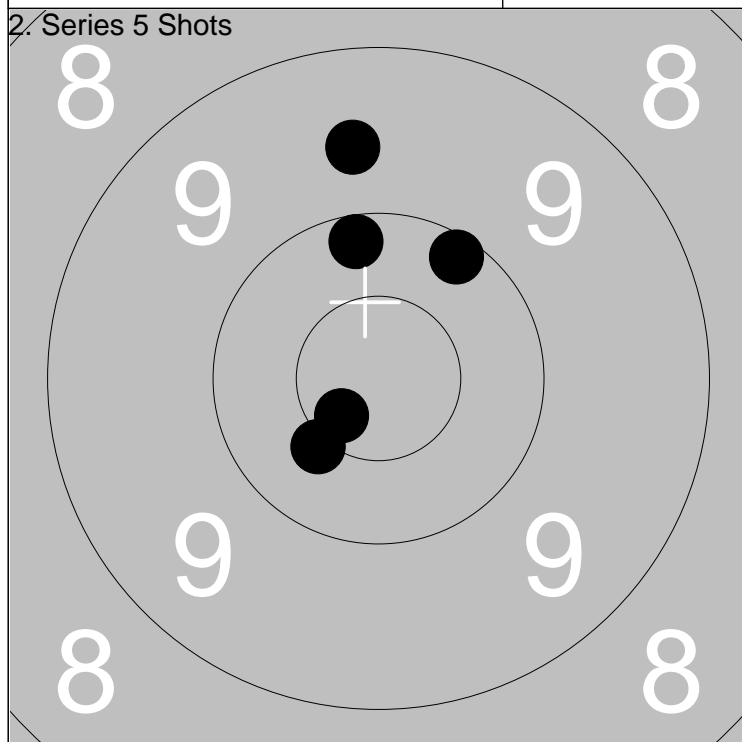

4: *10.4 ↙	Series 47.0
5: 10.2 ↑	
Total 292.0	

1: 9.6 ↗	Series 47.0
2: 8.9 ↑	
3: 10.0 ↑	
Total 292.0	

4: *10.7 ←	Series 47.0
5: *10.6 ↖	
Total 292.0	

1: 9.6 ↗	Series 47.0
2: 8.9 ↑	
3: 10.0 ↑	
Total 292.0	

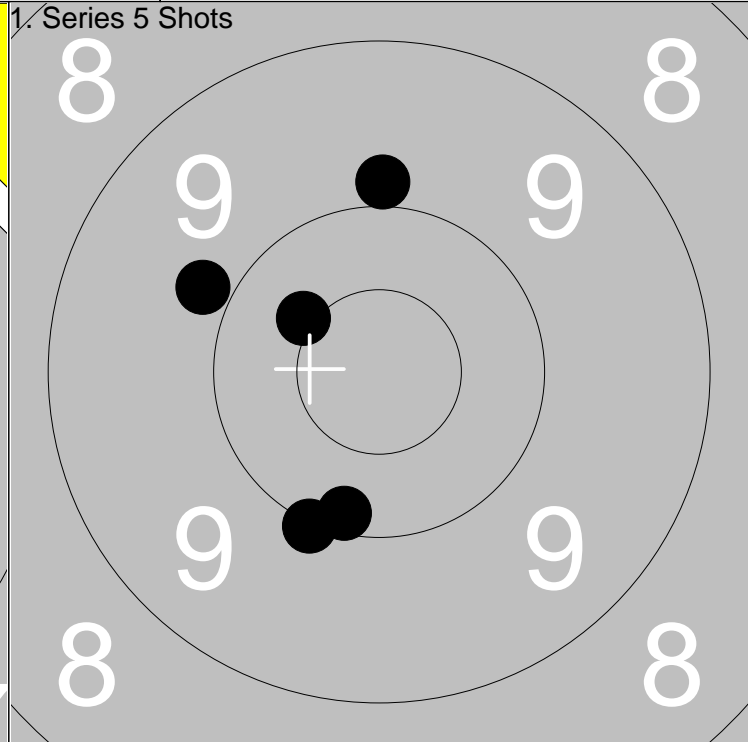
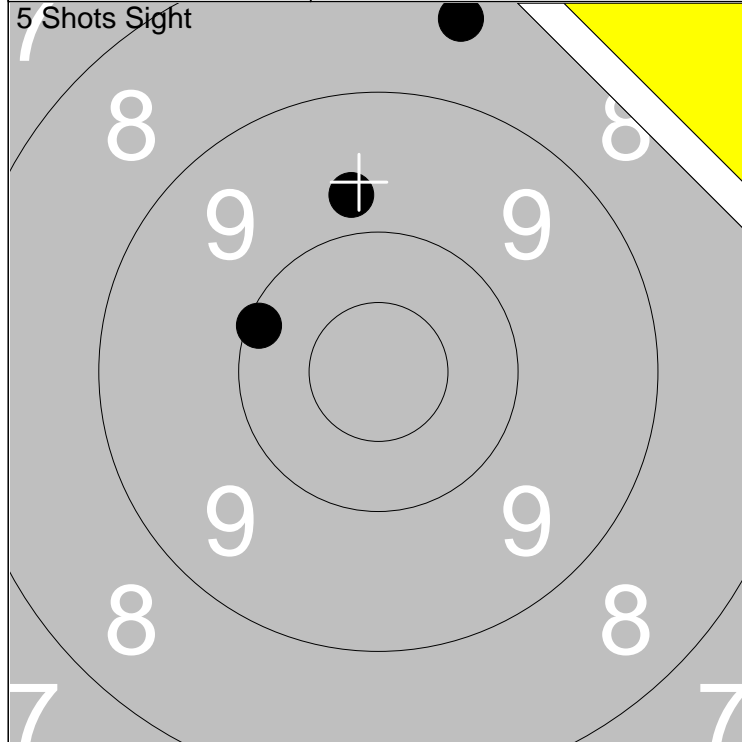

1: 9.7 ↑	Series	27.0
2: 8.4 ↑		
3: 10.1 ↙		
Total		146.0

1: 10.1 ↓	Series	48.0
2: 9.8 ↙		
3: 10.0 ↓		
4: 9.9 ↑		
5: *10.4 ↙		
Total		194.0

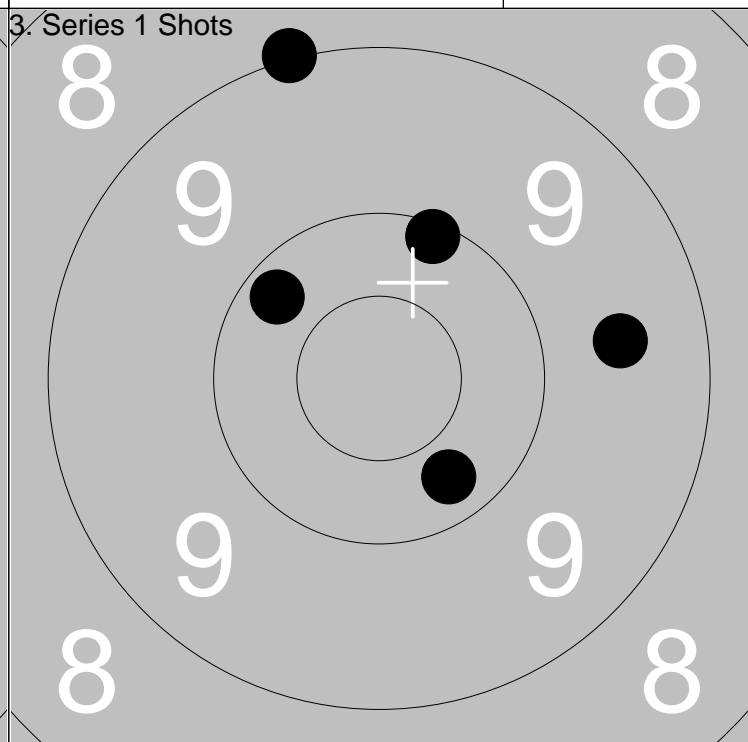
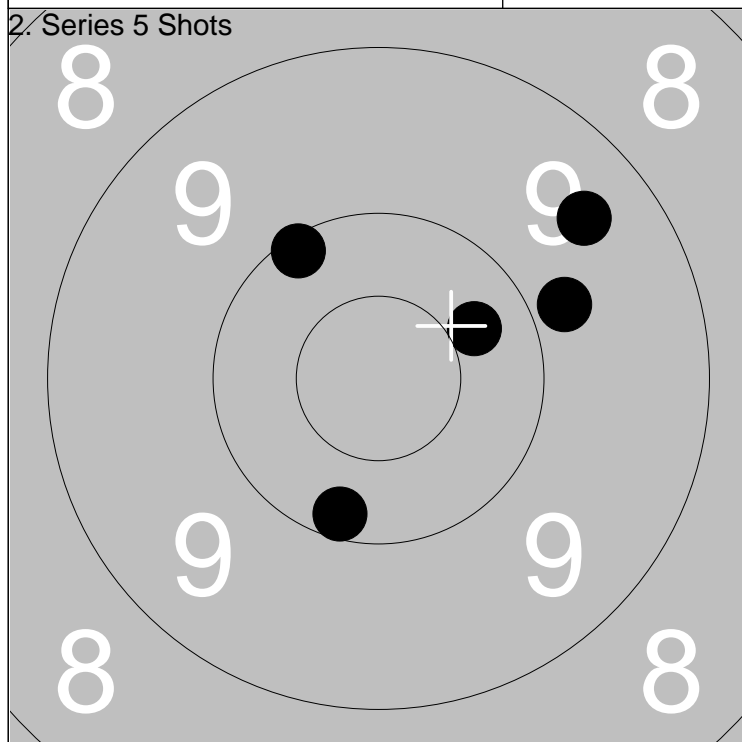

1: 9.5 ↗	Series	48.0
2: 10.2 ↓		
3: 9.8 ↗		
4: 10.3 ↗		
5: 10.1 ↙		
Total		242.0

1: 9.6 →	Series	48.0
2: 10.1 ↑		
3: 10.2 ↙		
4: 9.0 ↑		
5: 10.3 ↓		
Total		290.0

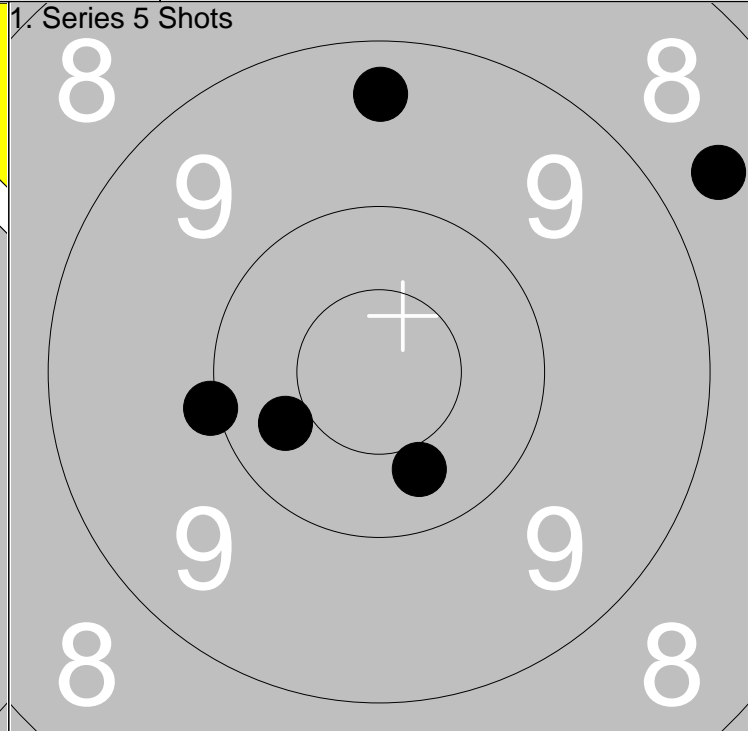
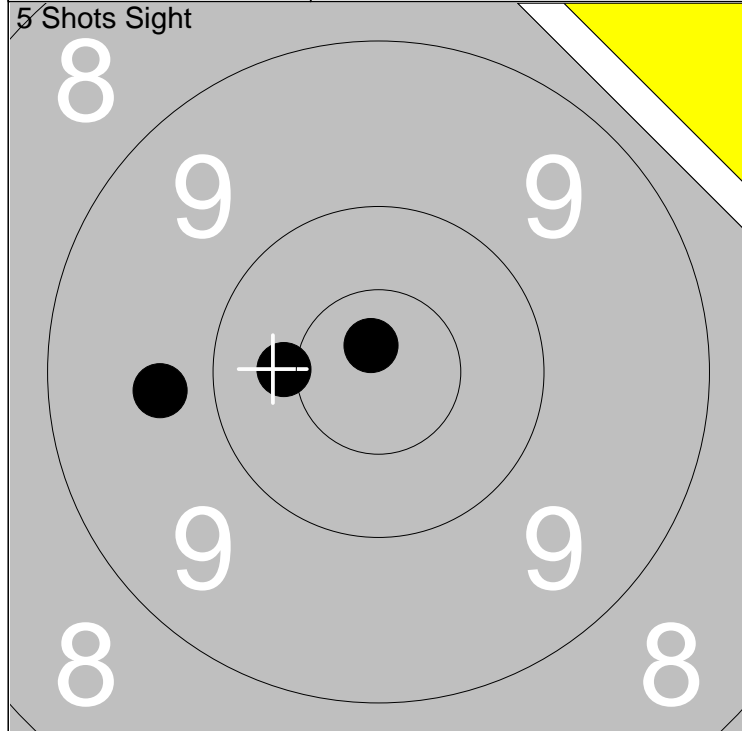

1: *10.8↑	Series	29.0
2: *10.4←		
3: 9.7 ←		
Total		145.0

1: 10.4 ↓	Series	47.0
2: 10.4 ↙		
3: 9.4 ↑		
4: 10.0 ←		
5: 8.6 ↗		
Total		192.0

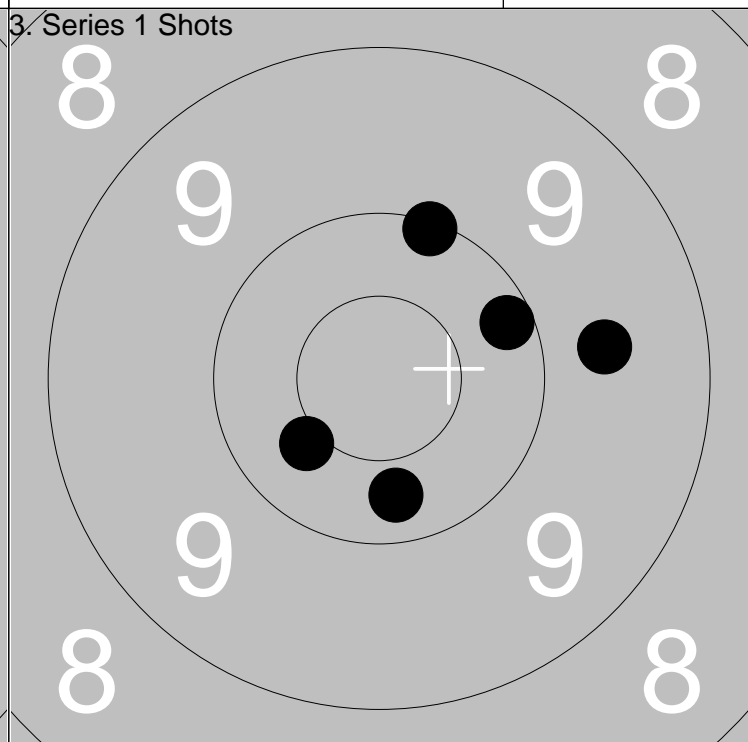
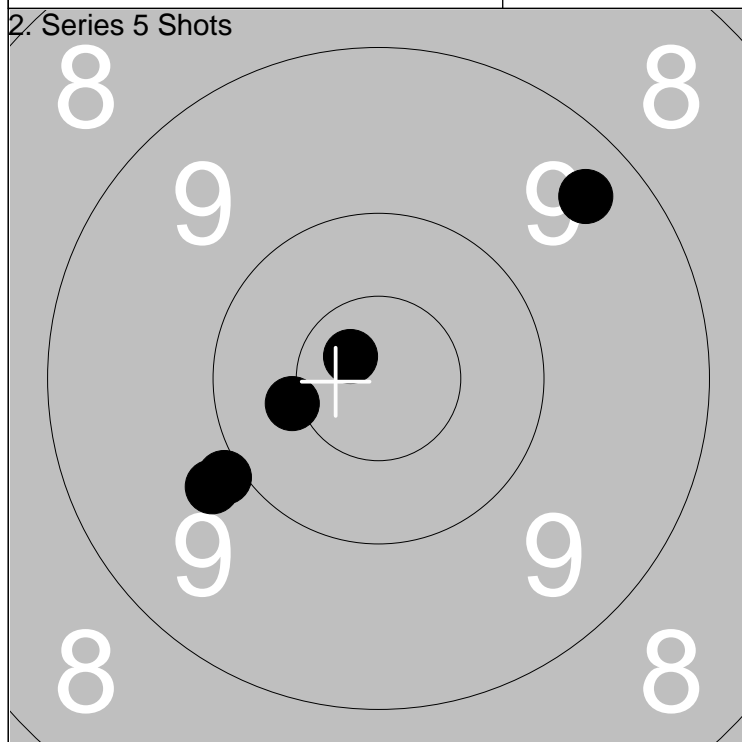

1: 9.9 ↙	Series	47.0
2: *10.7↘		
3: 9.8 ↙		
4: *10.4←		
5: 9.4 ↗		
Total		239.0

1: 9.7 →	Series	49.0
2: 10.3 ↓		
3: 10.1 ↑		
4: 10.2 ↗		
5: 10.4 ↙		
Total		288.0

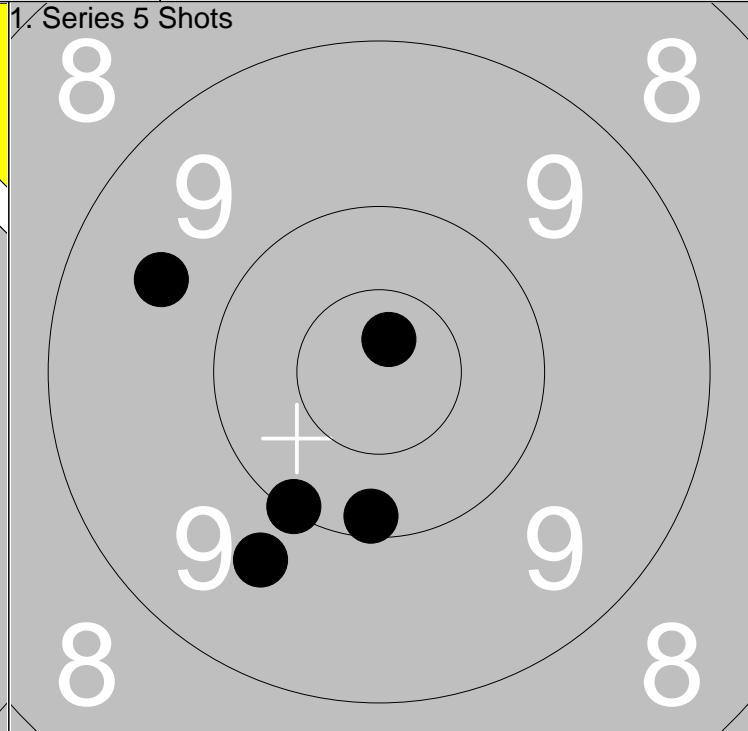
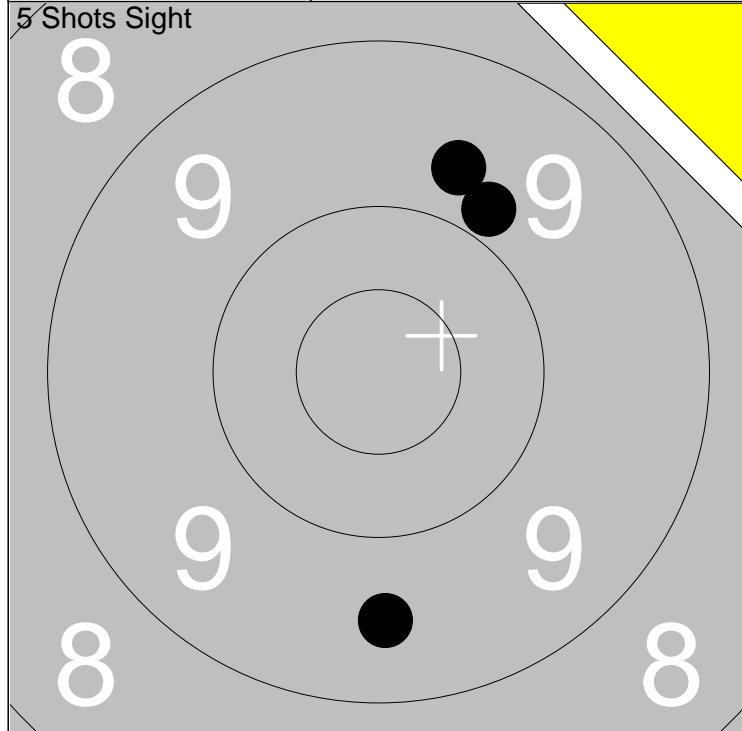

1: 9.7 ↗	Series	27.0
2: 9.8 ↗		
3: 9.5 ↓		
Total		145.0

1: 10.1 ↘	Series	48.0
2: 10.1 ↓		
3: 9.7 ↘		
4: *10.8 ↗		
5: 9.6 ↙		
Total		193.0

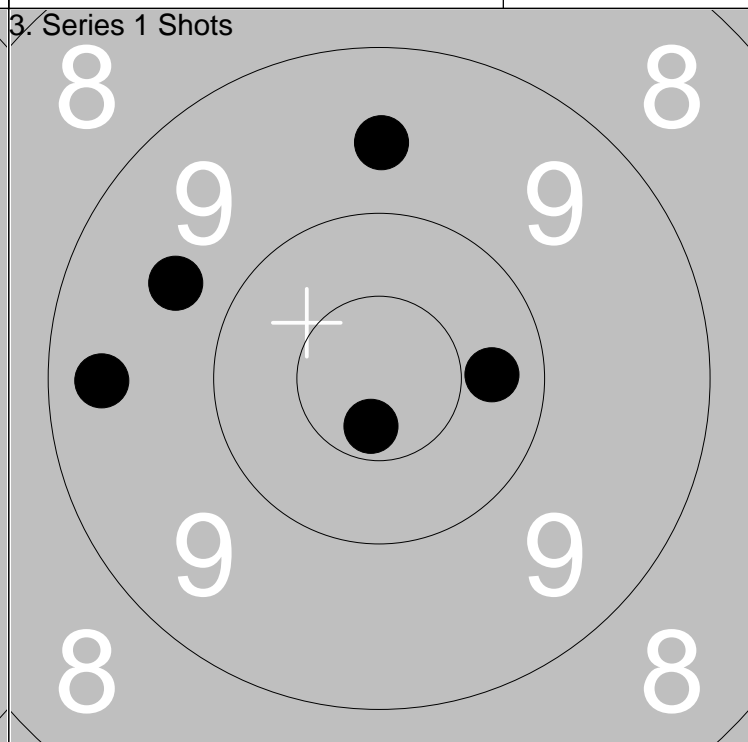
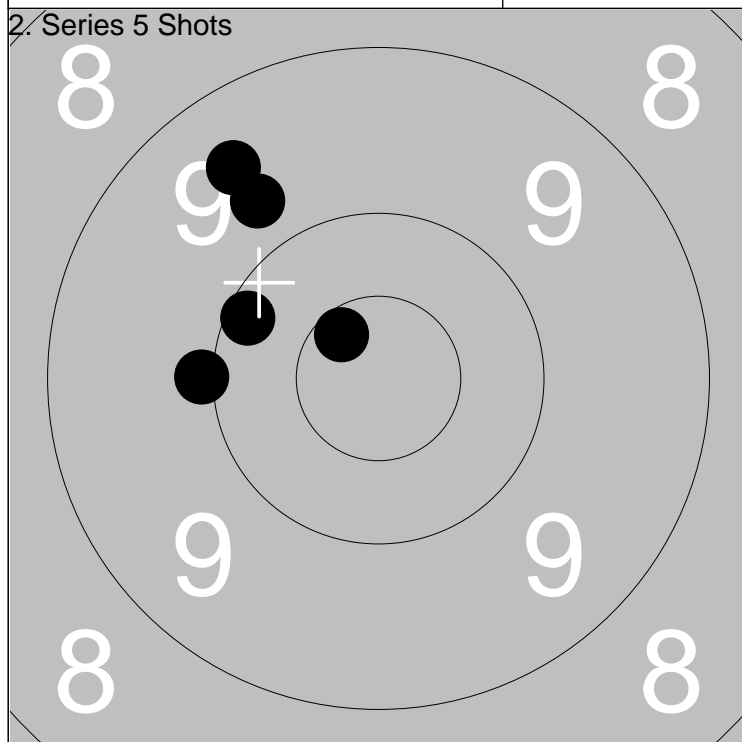

1: 9.5 ↗	Series	48.0
2: *10.6 ↗		
3: 9.7 ↗		
4: 10.0 ←		
5: 10.1 ↙		
Total		241.0

1: 10.3 →	Series	47.0
2: 9.6 ↑		
3: 9.4 ←		
4: 9.7 ↙		
5: *10.7 ↓		
Total		288.0

Relay 4	Lane 15	Filip Jansson	
-------------------	-------------------	----------------------	--

300m	Söderala	U	Gä
------	----------	---	----

2013-07-07	Tavelträffen A 2013	Ramselefors SKF
------------	---------------------	-----------------

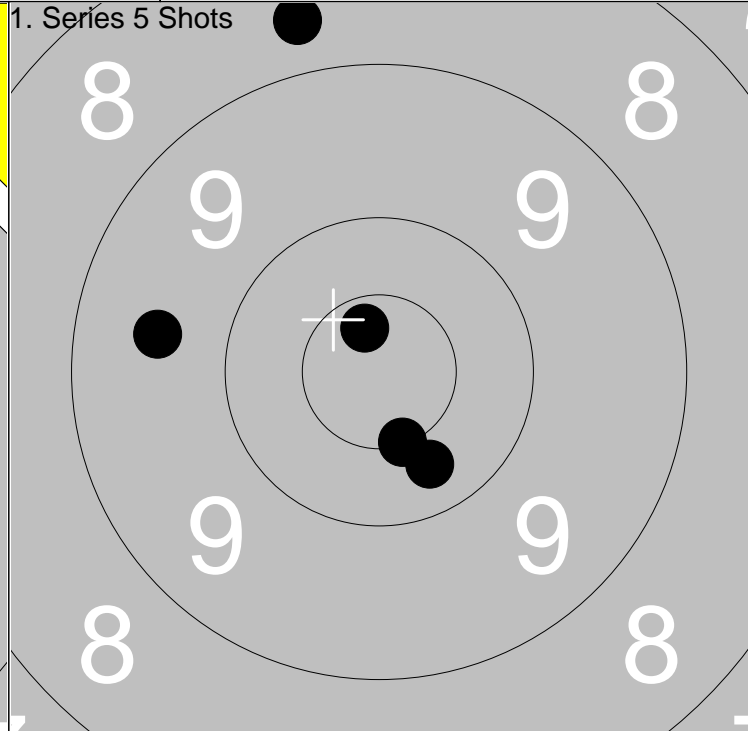
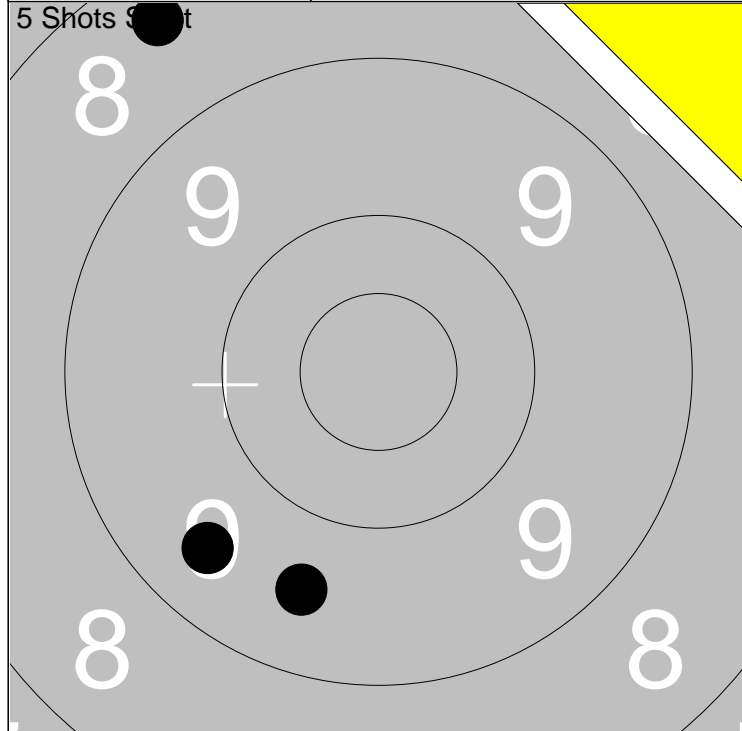

1: 9.6 ↓	Series	26.0
2: 9.5 ↙		
3: 8.4 ↗		
Total		141.0

1: *10.5 ↓	Series	47.0
2: 8.7 ↑		
3: 10.3 ↓		
4: 9.6 ←		
5: *10.7 ↑		
Total		188.0

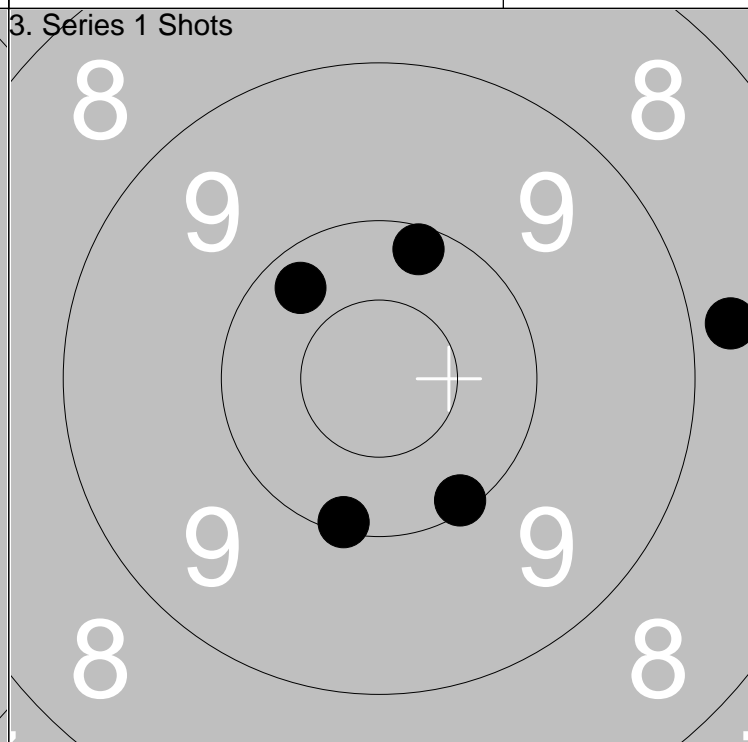
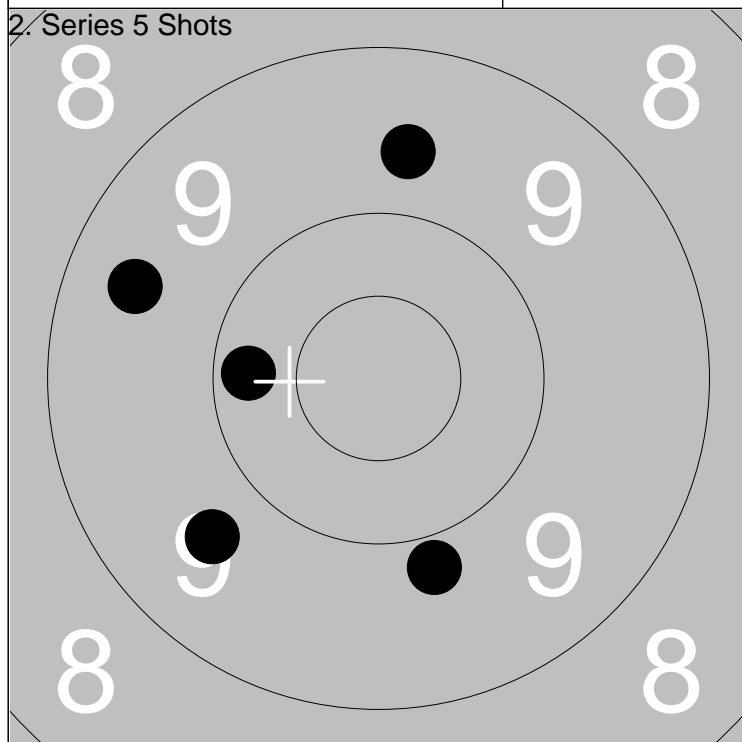

1: 9.5 ←	Series	46.0
2: 9.6 ↑		
3: 9.8 ↓		
4: 9.6 ↙		
5: 10.2 ←		
Total		234.0

1: 10.1 ↓	Series	48.0
2: 10.2 ↑		
3: 10.2 ↖		
4: 8.8 →		
5: 10.1 ↓		
Total		282.0

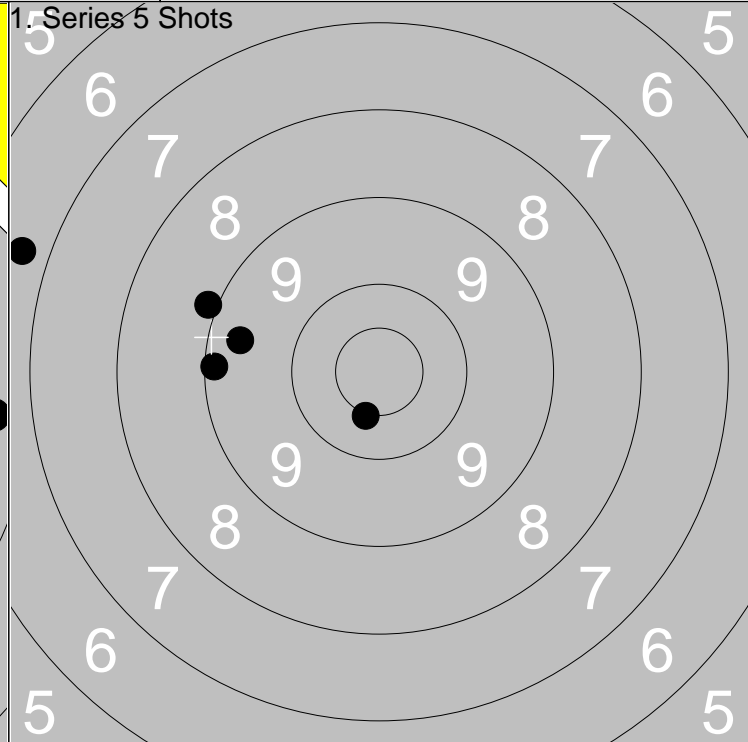
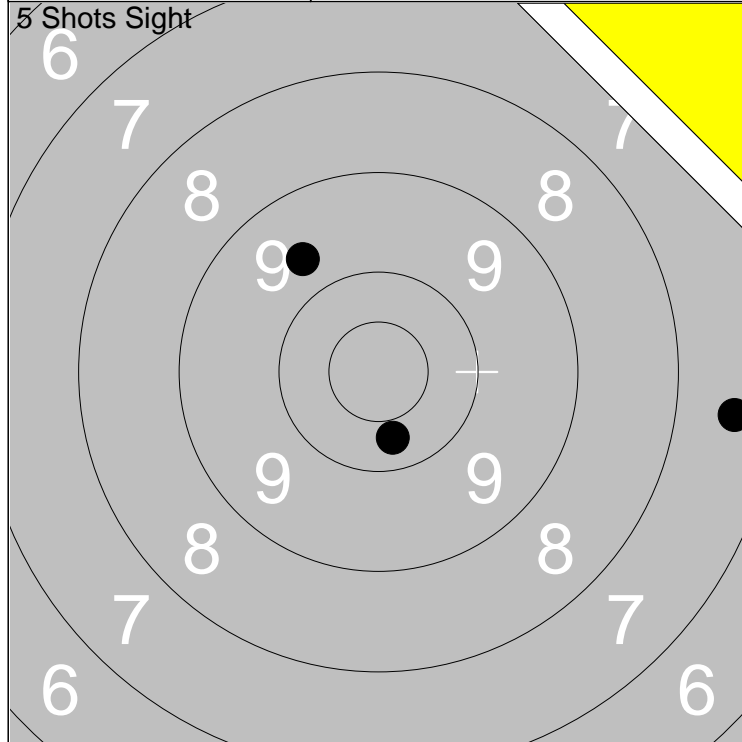

1: 10.3 ↓	Series 26.0
2: 7.4 →	
3: 9.7 ↗	
Total 127.0	

1: 9.1 ←	Series 42.0
2: 8.9 ←	
3: 6.7 ←	
4: 9.4 ←	
5: *10.5 ↓	
Total 169.0	

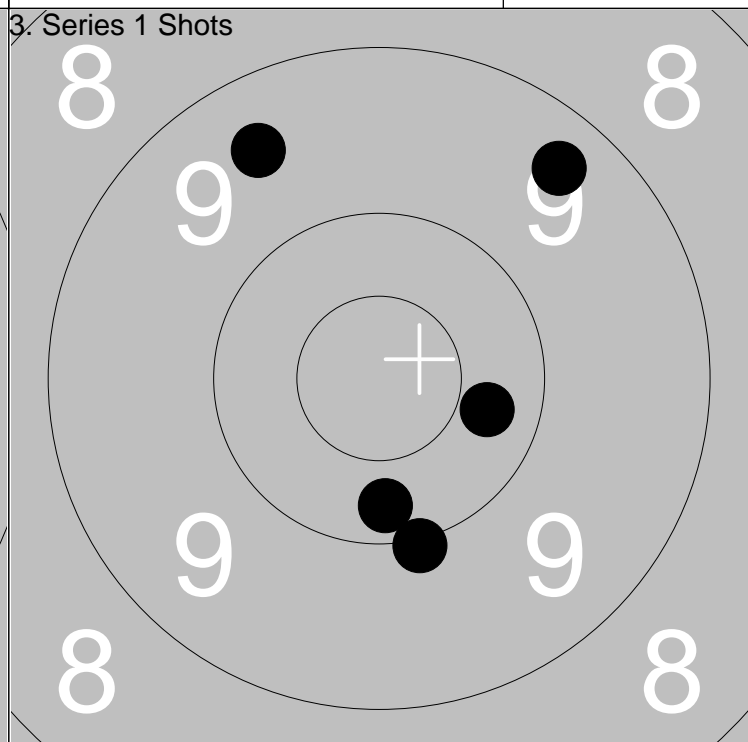
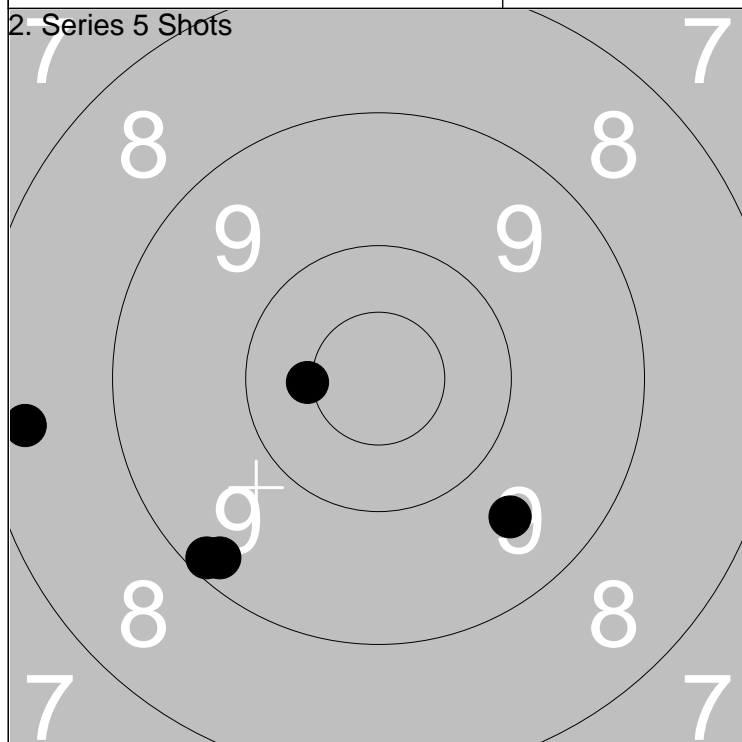

1: 9.2 ↙	Series 45.0
2: 9.2 ↙	
3: 8.3 ←	
4: 9.6 ↓	
5: *10.5 ←	
Total 214.0	

1: 10.2 ↓	Series 48.0
2: 10.0 ↓	
3: 10.3 →	
4: 9.4 ↗	
5: 9.5 ↖	
Total 262.0	

Relay 4	Lane 18	Leif Ögren		
-------------------	-------------------	-------------------	--	--

300m	Umeå	D	Vb
------	------	---	----

2013-07-07	Tavelträffen A 2013	Ramselefors SKF
------------	---------------------	-----------------

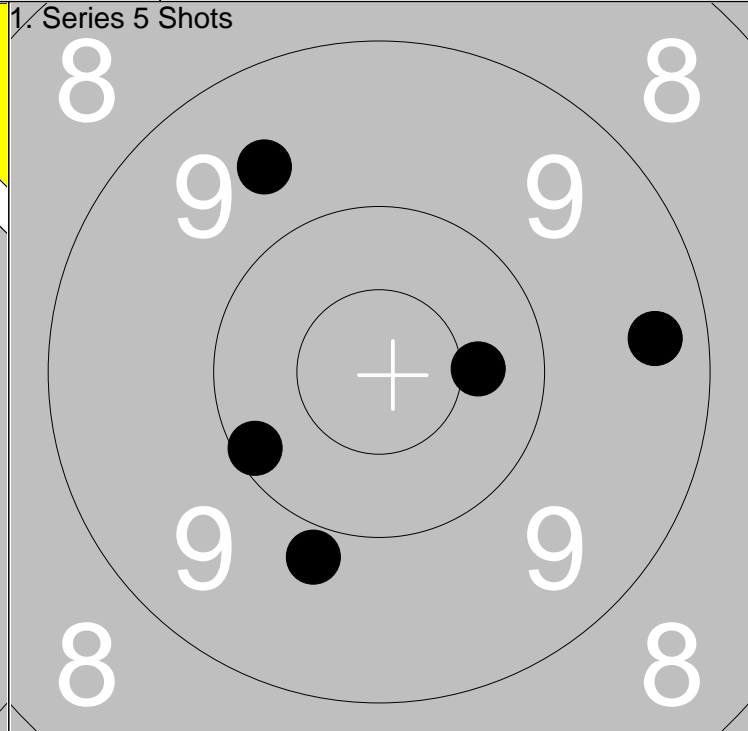
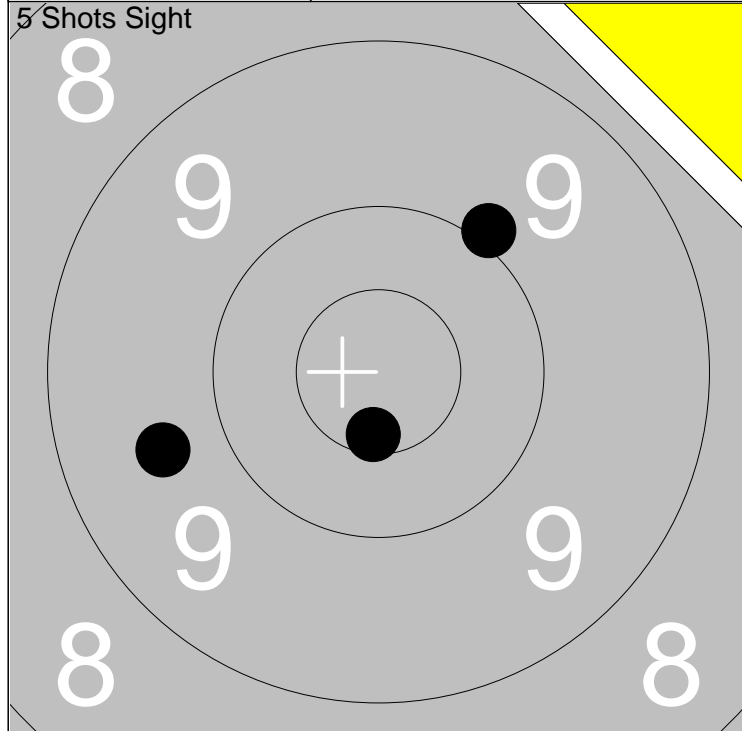

1: 9.6 ←	Series	28.0
2: *10.6 ↓		
3: 9.9 ↗		
Total		144.0

1: 9.4 →	Series	47.0
2: 10.1 ↙		
3: 9.6 ↖		
4: 9.8 ↓		
5: 10.4 →		
Total		191.0

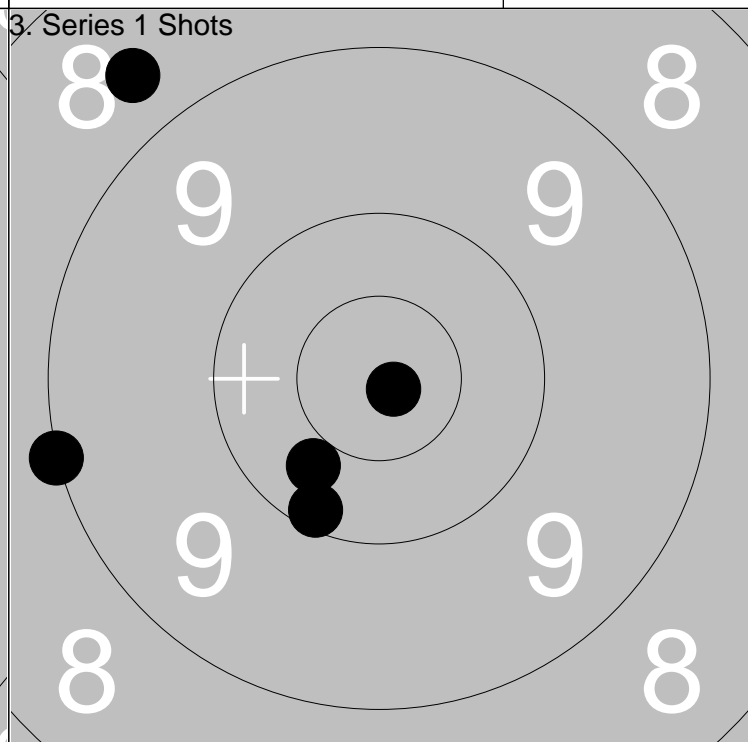
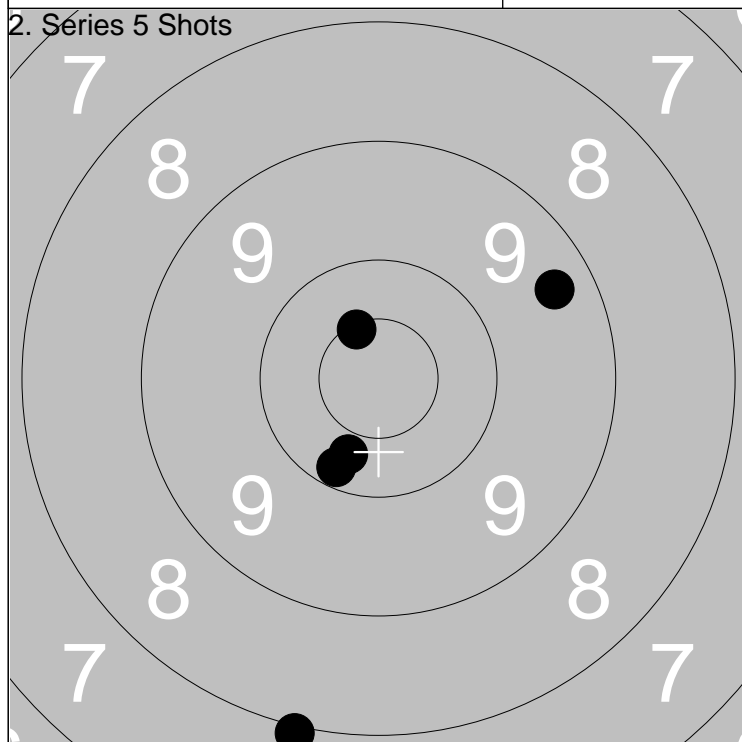

1: 10.2 ↓	Series	47.0
2: *10.5 ↖		
3: 9.4 ↗		
4: 10.3 ↓		
5: 8.0 ↓		
Total		238.0

1: 10.3 ↓	Series	47.0
2: *10.9 ↘		
3: 8.7 ↖		
4: 9.0 ←		
5: 10.1 ↓		
Total		285.0

Relay 4	Lane 19	Håkan Lidman		
-------------------	-------------------	---------------------	--	--

300m	Skellefteå	D	Vb
------	------------	---	----

2013-07-07	Tavelträffen A 2013	Ramselefors SKF
------------	---------------------	-----------------

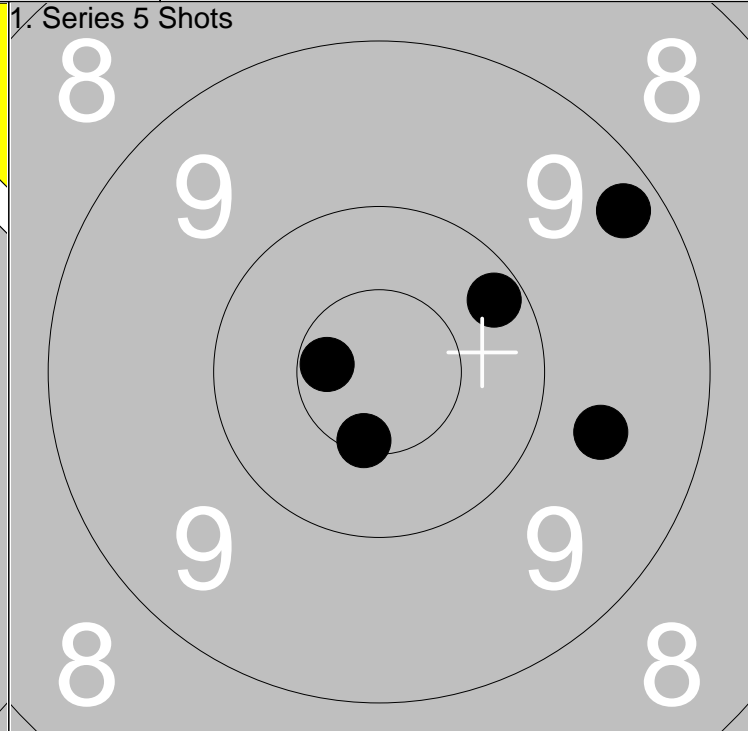
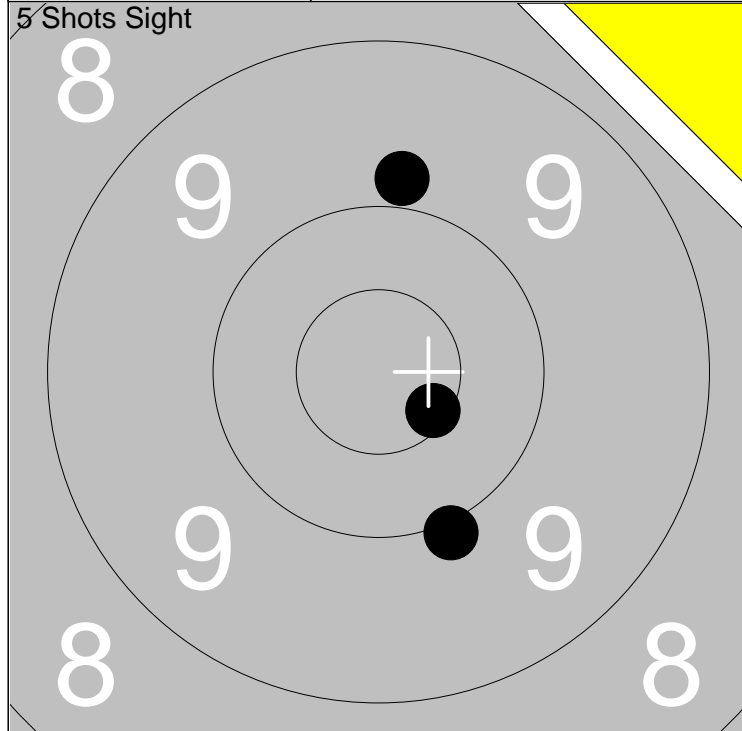

1: 9.9 ↑	Series	29.0
2: 10.0 ↓		
3: *10.6 ↘		
Total		144.0

1: 10.2 ↗	Series	48.0
2: *10.6 ↓		
3: 9.3 ↗		
4: 9.6 →		
5: *10.7 ↙		
Total		192.0

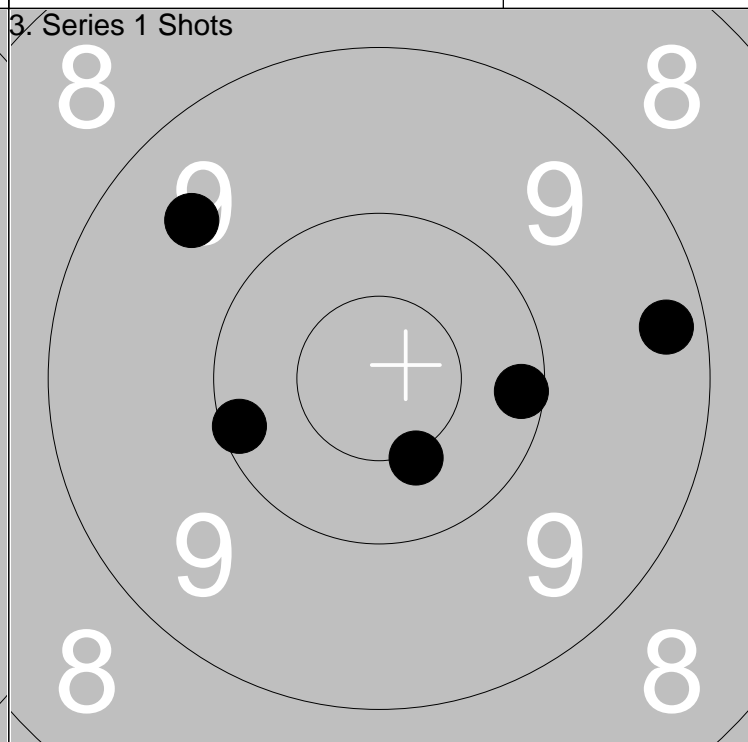
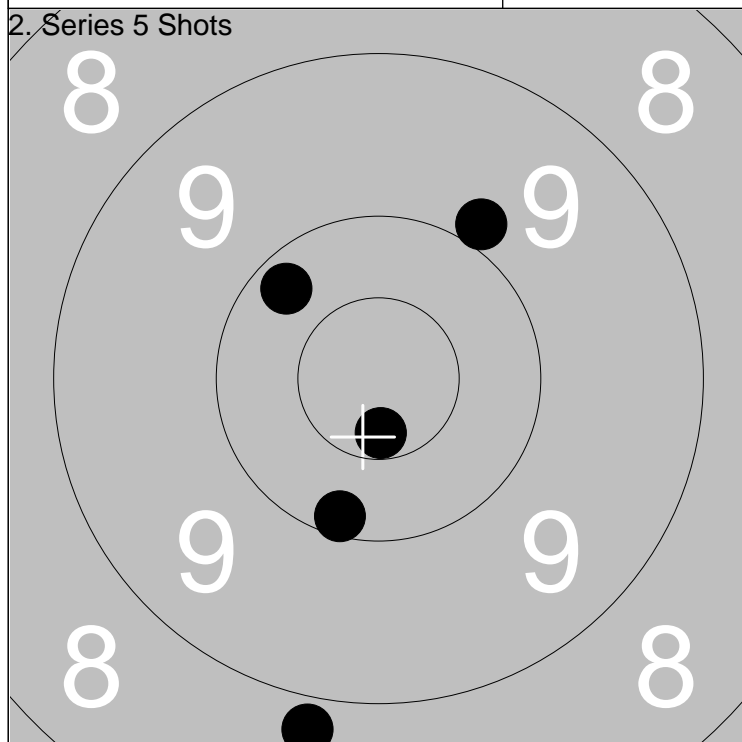

1: 9.9 ↗	Series	47.0
2: *10.6 ↓		
3: 10.1 ↓		
4: 8.8 ↓		
5: 10.2 ↖		
Total		239.0

1: *10.5 ↓	Series	48.0
2: 10.1 ↙		
3: 9.5 ↖		
4: 10.2 →		
5: 9.3 →		
Total		287.0

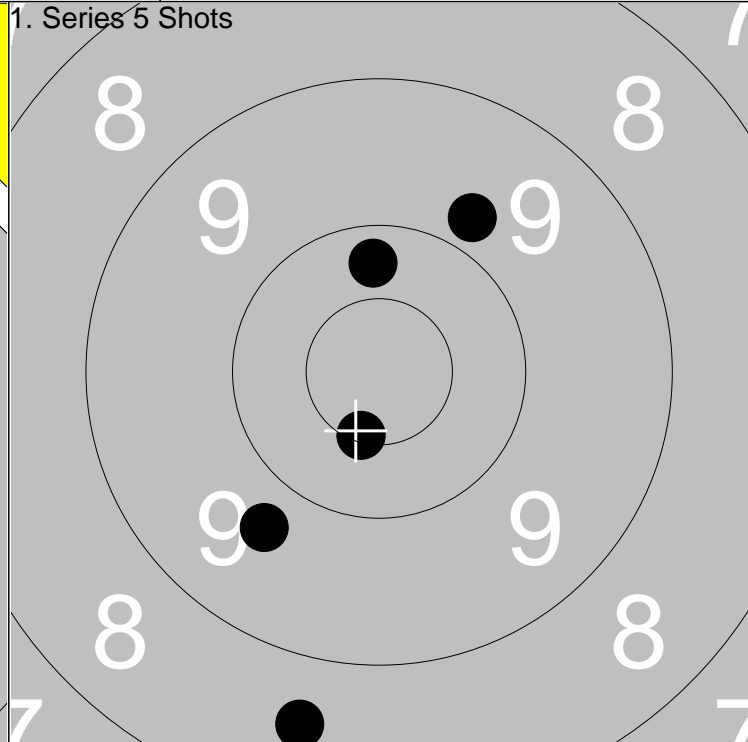
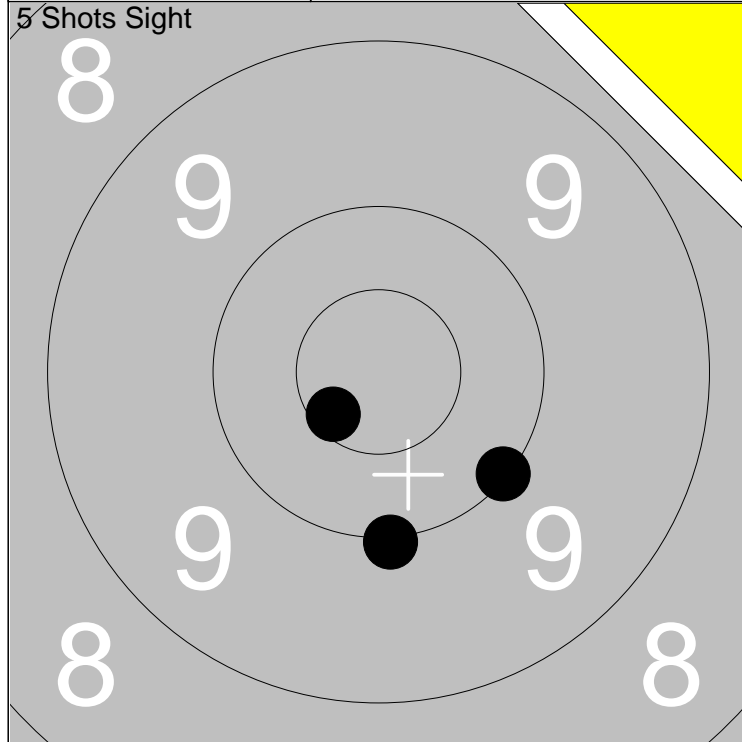

1: 10.0 ↘	Series	30.0
2: *10.6 ↙		
3: 10.0 ↓		
Total		143.0

1: *10.5 ↓	Series	46.0
2: 9.8 ↗		
3: 9.7 ↙		
Total		189.0

4: 10.3 ↑	Series	47.0
5: 8.6 ↓		
Total		

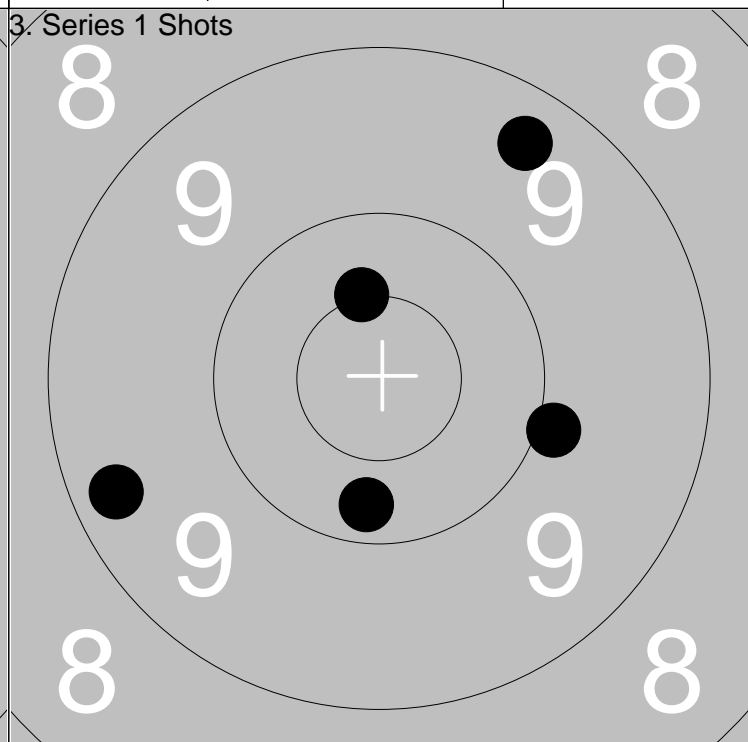
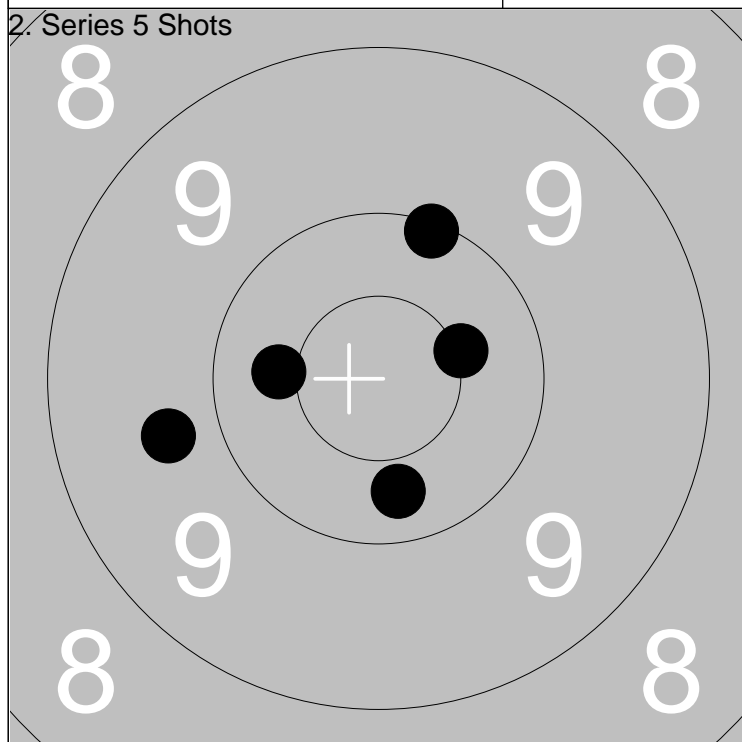

1: 10.4 ←	Series	49.0
2: 9.7 ←		
3: 10.3 ↓		
Total		238.0

4: *10.5 →	Series	47.0
5: 10.1 ↗		
Total		

1: 9.9 →	Series	47.0
2: 9.4 ↗		
3: 9.3 ←		
Total		285.0

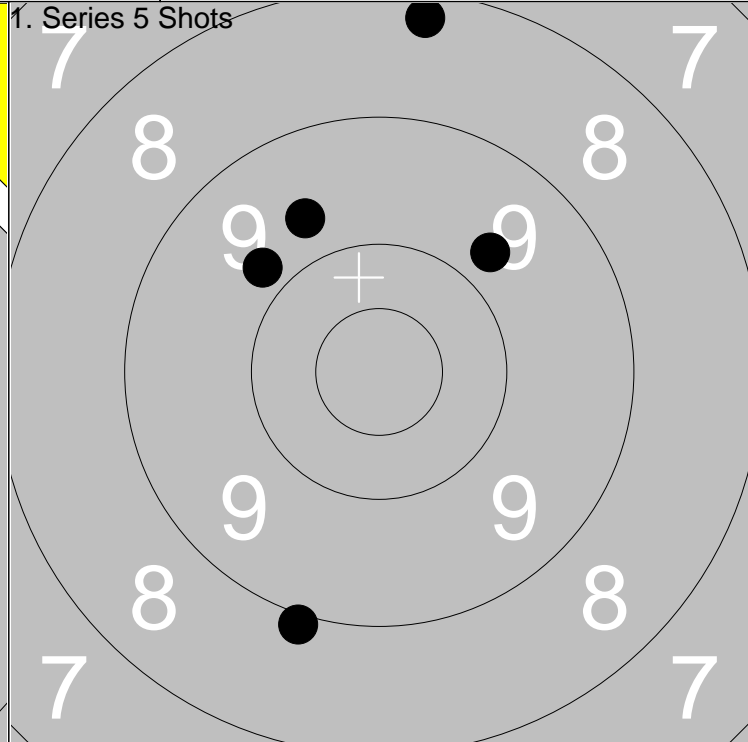
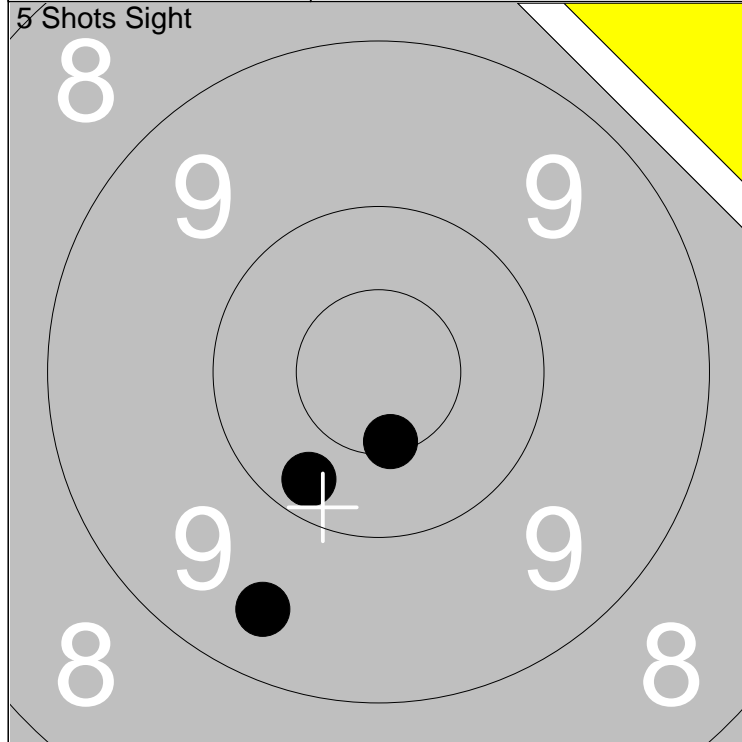

1: 10.2 ↘	Series	29.0
2: 9.4 ↘		
3: *10.6 ↘		
Total		142.0

1: 8.2 ↑	Series	44.0
2: 9.8 ↖		
3: 9.7 ↗		
4: 9.7 ↖		
5: 9.0 ↘		
Total		186.0

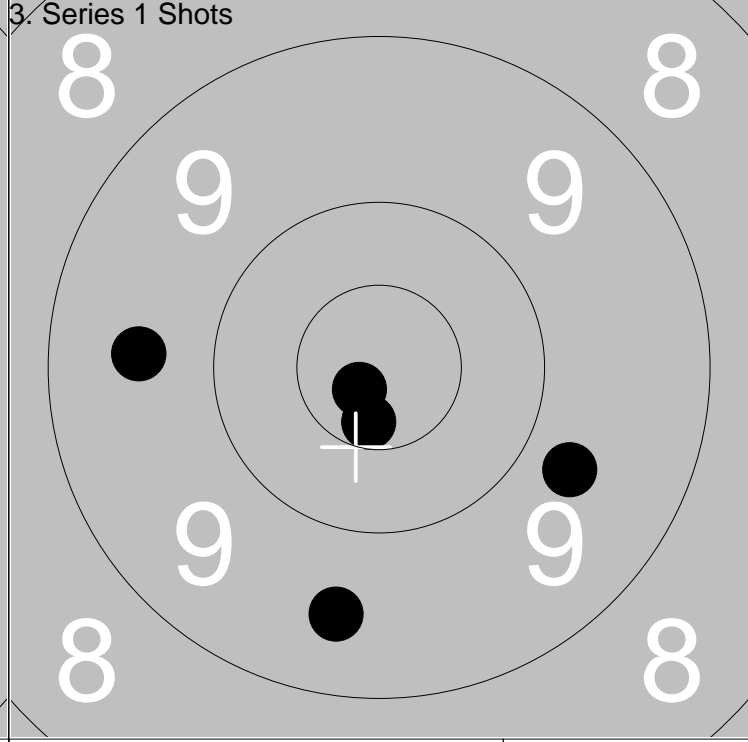
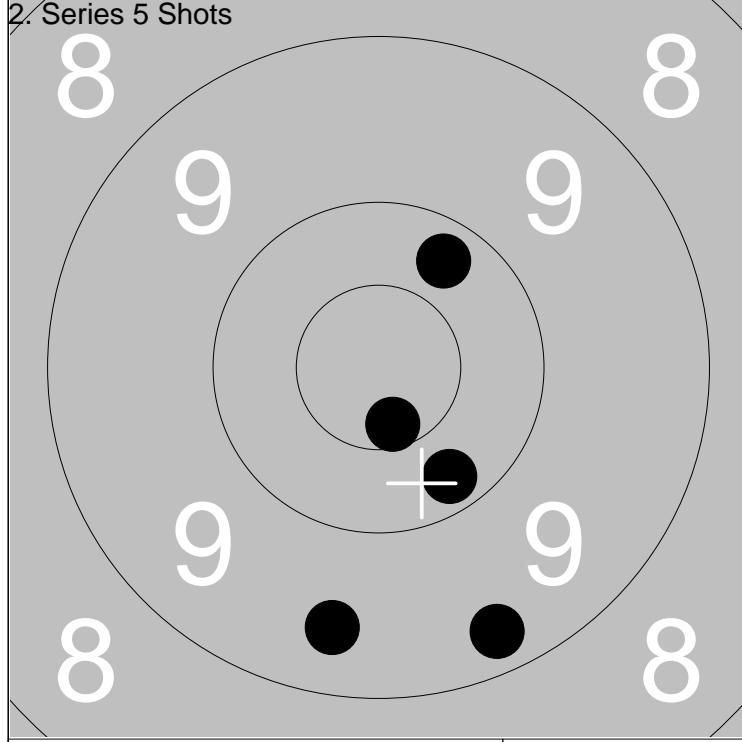

1: 10.2 ↗	Series	48.0
2: 10.2 ↘		
3: *10.6 ↘		
4: 9.3 ↘		
5: 9.4 ↘		
Total		234.0

1: *10.6 ↘	Series	47.0
2: 9.6 ←		
3: 9.5 ↘		
4: *10.8 ↘		
5: 9.7 ↘		
Total		281.0

<p>5 Shots Sight</p>	<p>1. Series 5 Shots</p>	<p>1: 8.7 ↗ 2: 10.3 ↘ 3: 9.8 →</p> <p>1: 10.0 ↗ 2: 8.9 ↖ 3: 9.5 ↘ 4: *10.5 ↗ 5: *10.5 →</p>
Series 27.0	Series 47.0	
Total 148.0	Total 195.0	

<p>2. Series 5 Shots</p>	<p>3. Series 1 Shots</p>	<p>1: 10.3 ← 2: 9.0 ↘ 3: 9.7 ↙ 4: 9.6 ↘ 5: 9.6 →</p> <p>1: 9.6 ↗ 2: 9.5 → 3: 9.6 ↗ 4: *10.8 ↘ 5: *10.8 ↖</p>
Series 46.0	Series 47.0	
Total 241.0	Total 288.0	

<p>1. Series 1 Shots Sh.off</p>	<p>2. Series 1 Shots Sh.off</p>	<p>1: *10.5 ↗</p> <p>1: 9.4 ↘</p>
Series 10.0	Series 9.0	
Total 288.0	Total 288.0	

Relay 5	Lane 2	Sara Borg		
-------------------	------------------	------------------	--	--

300m	Ununge	B	St
------	--------	---	----

2013-07-07	Tavelträffen A 2013	Ramselefors SKF	
------------	---------------------	-----------------	--

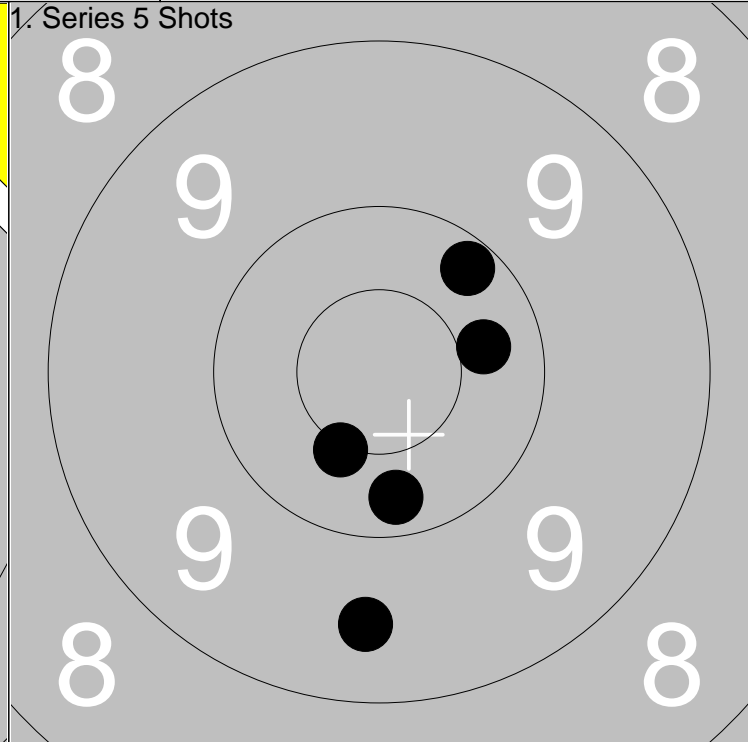
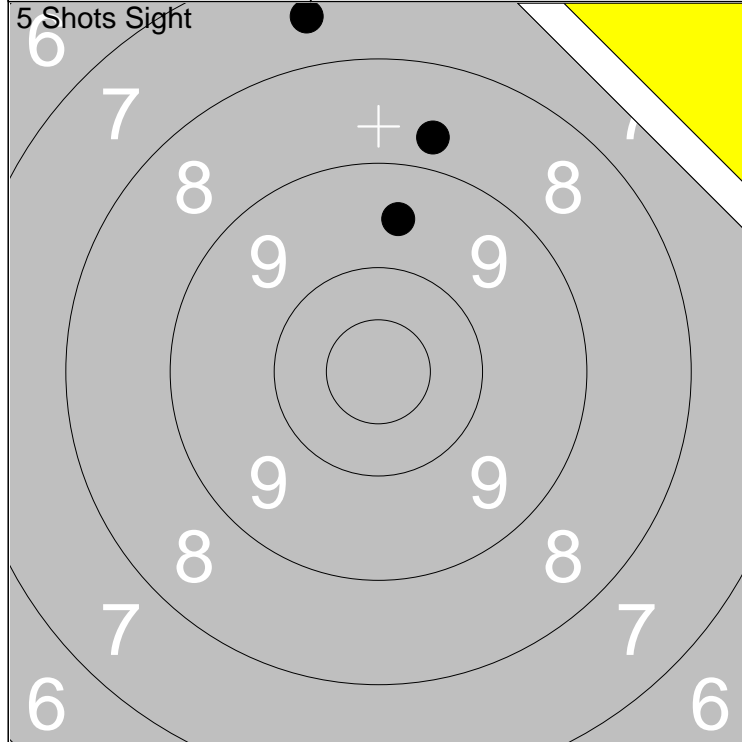

1: 7.5 ↑	Series	24.0
2: 8.7 ↑		
3: 9.6 ↑		
Total		147.0

1: 10.2 ↗	Series	49.0
2: 10.4 →		
3: 10.2 ↓		
4: 9.5 ↓		
5: *10.5 ↓		
Total		196.0

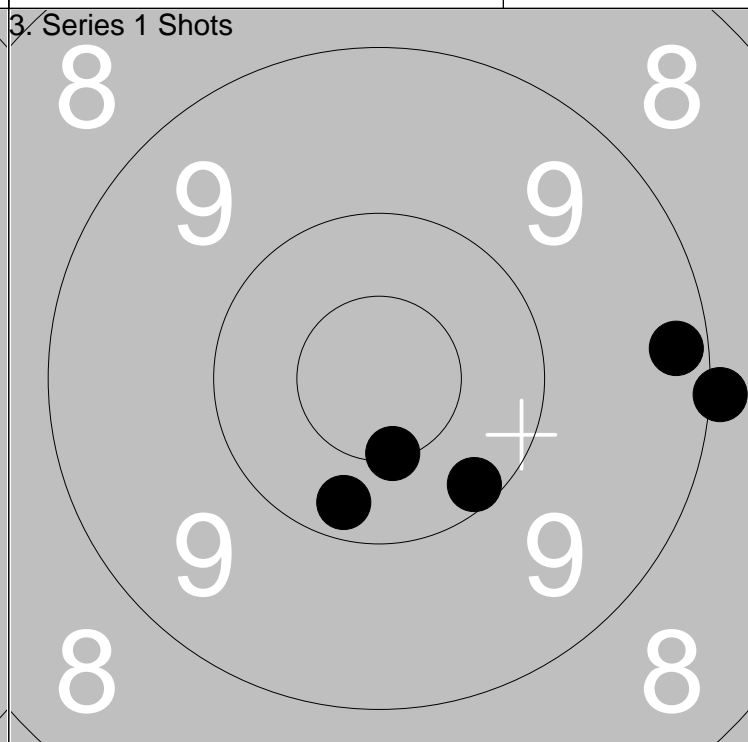
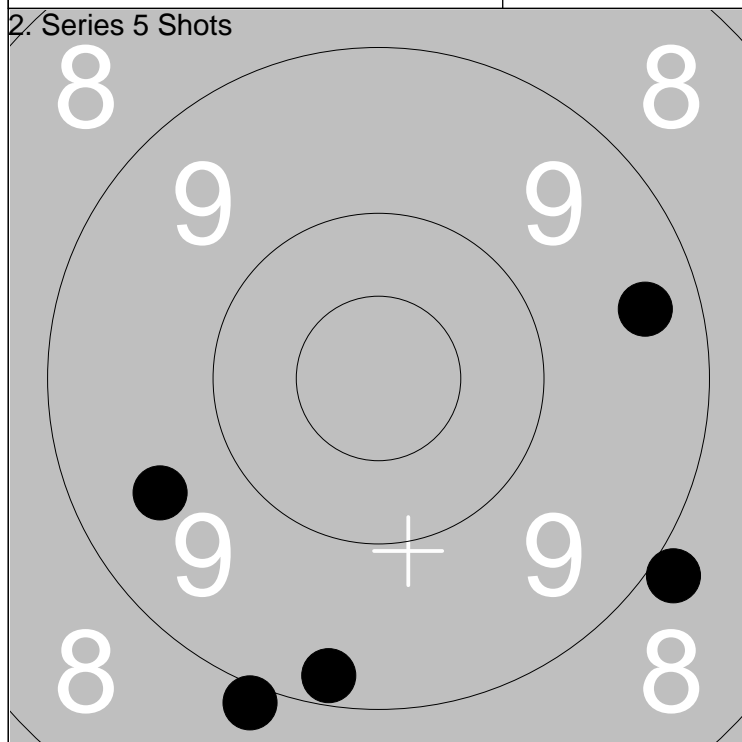

1: 8.9 ↓	Series	43.0
2: 9.2 ↓		
3: 9.5 ←		
4: 8.9 ↘		
5: 9.4 →		
Total		239.0

1: 9.0 →	Series	48.0
2: 9.2 →		
3: 10.2 ↘		
4: *10.5 ↓		
5: 10.2 ↓		
Total		287.0

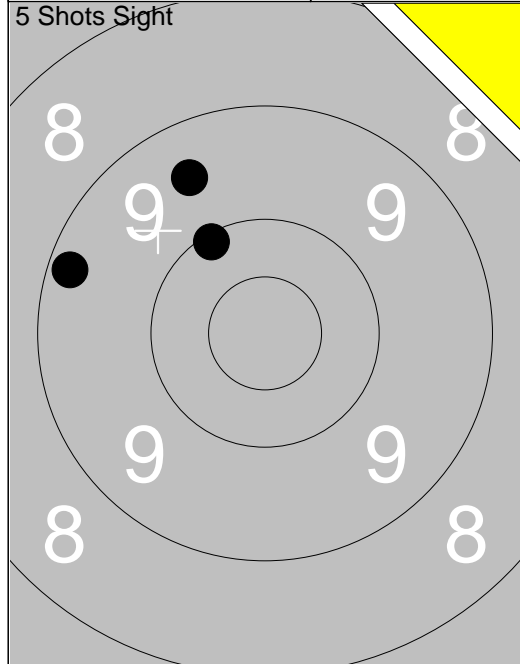

1:	9.2	↙
2:	10.1	↗
3:	9.5	↗
<hr/>		
Series	28.0	
Total	146.0	

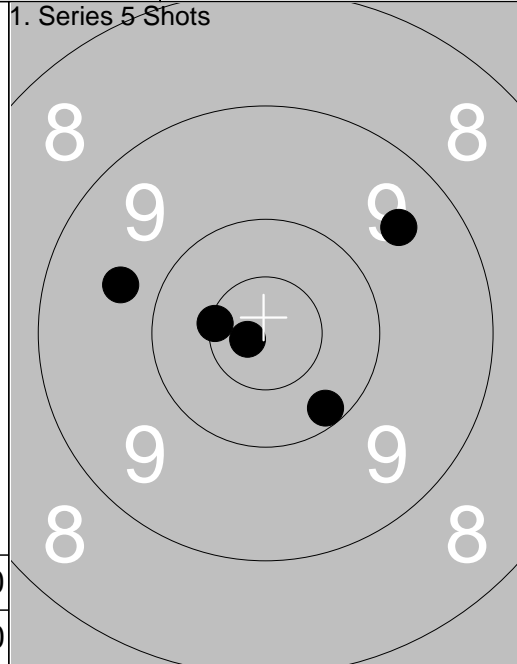

1:	10.2	↘
2:	*10.8	↙
3:	9.5	↗
4:	9.7	↙
5:	*10.5	↙
<hr/>		
Series	48.0	
Total	194.0	

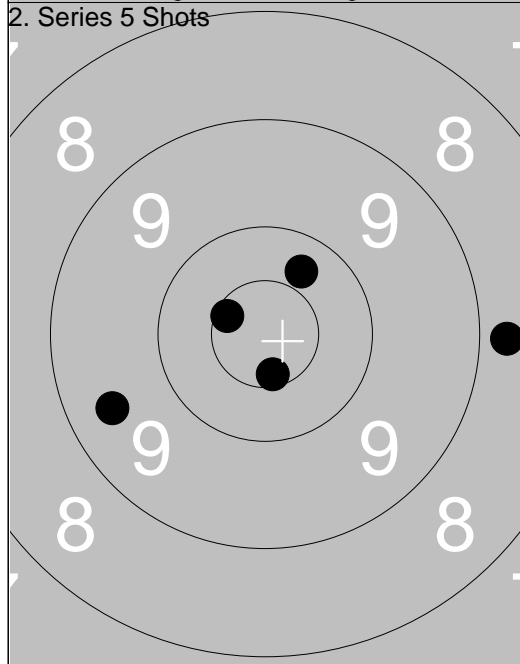

1:	*10.6	↘
2:	*10.6	↙
3:	9.5	↙
4:	8.8	→
5:	10.3	↗
<hr/>		
Series	47.0	
Total	241.0	

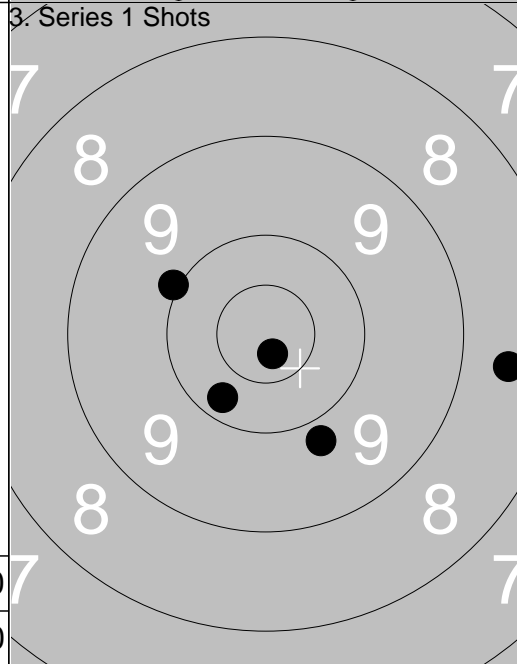

1:	10.0	↙
2:	*10.8	↘
3:	8.6	→
4:	10.2	↘
5:	9.8	↘
<hr/>		
Series	47.0	
Total	288.0	

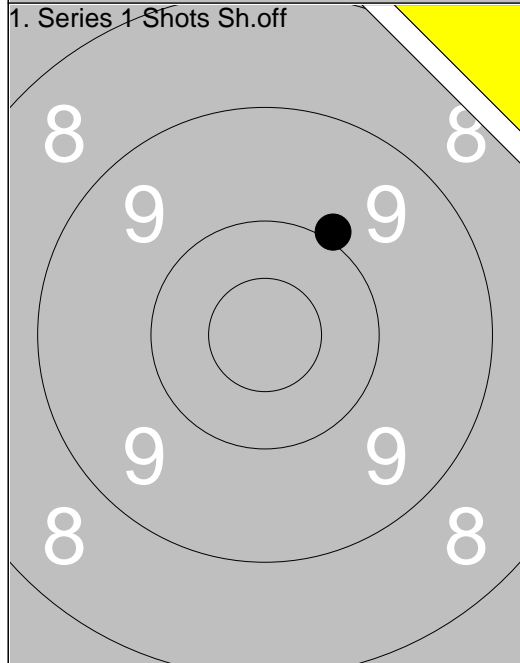

1:	9.9	↗
<hr/>		
Series	9.0	
Total	288.0	

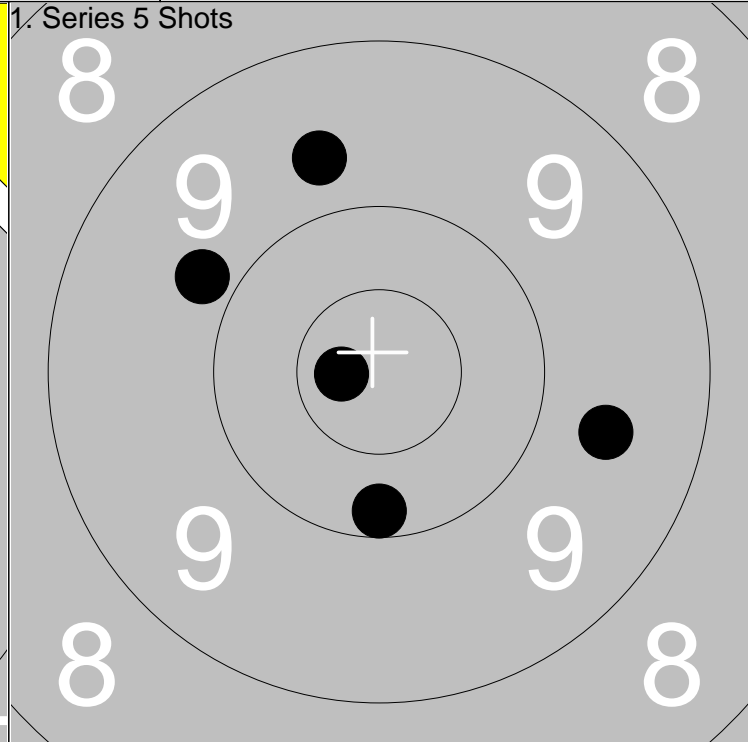
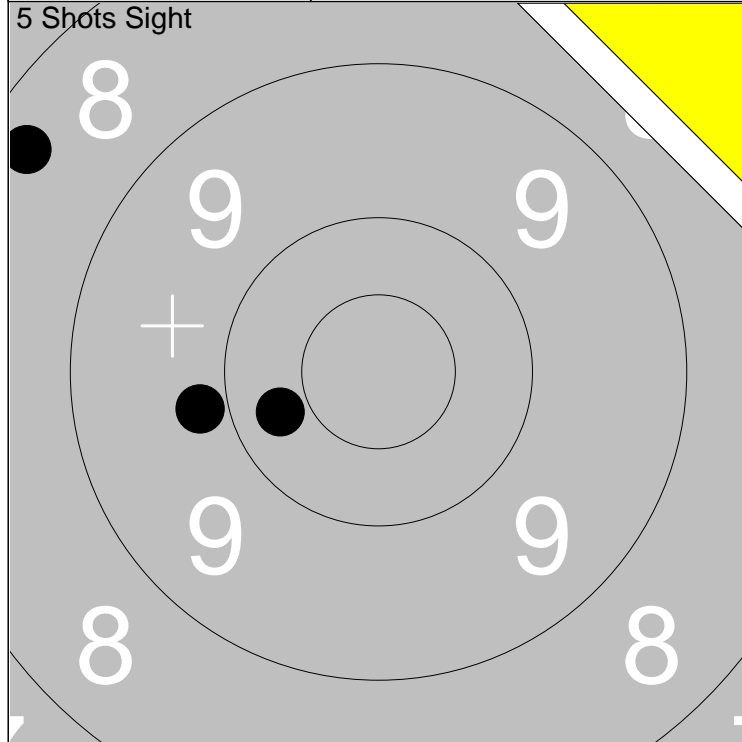

1: 8.3 ↖		Series	27.0
2: 10.3 ←		Total	145.0
3: 9.9 ←			

1: *10.7 ←		Series	47.0
2: 10.2 ↓		Total	192.0
3: 9.8 ↖			
4: 9.7 ↑			
5: 9.6 →			

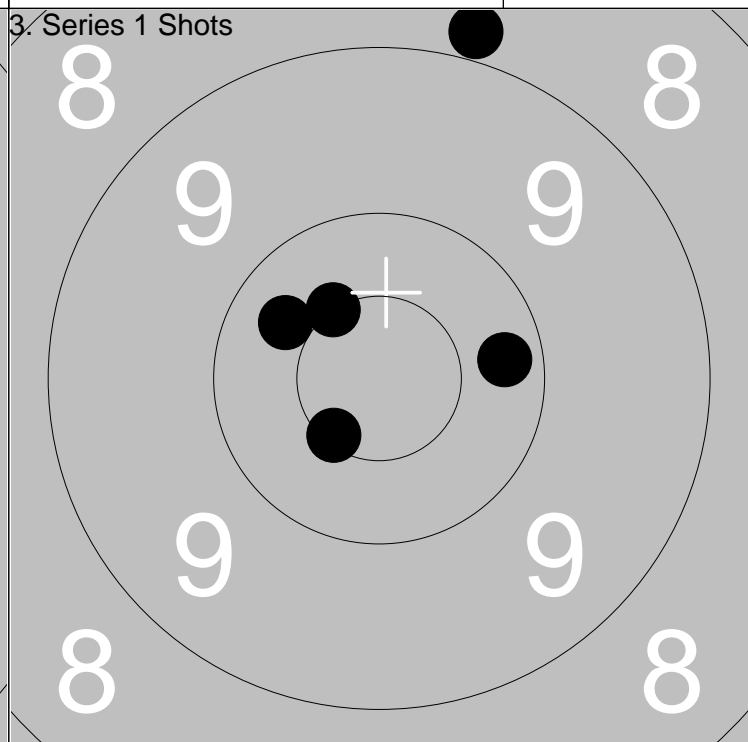
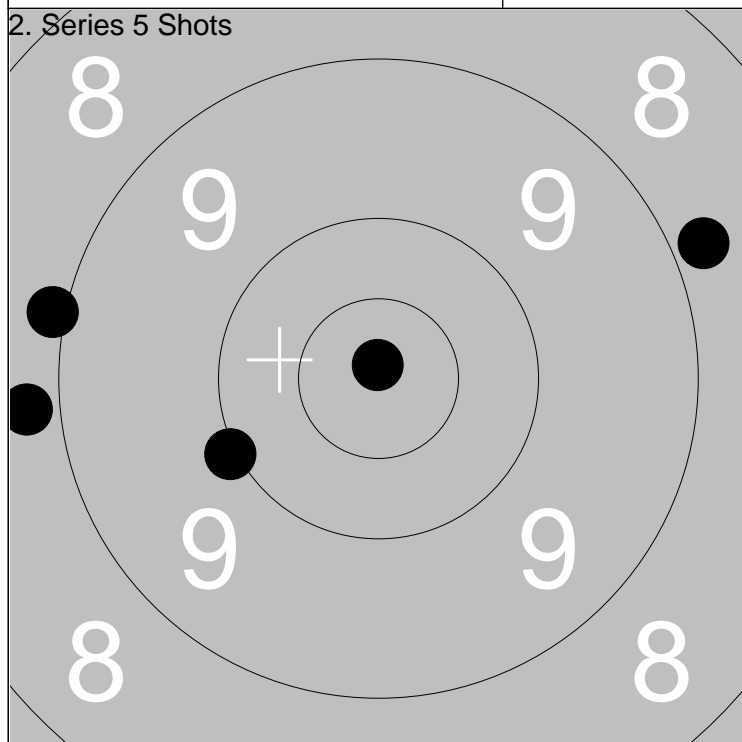

1: *10.9 ↑		Series	45.0
2: 10.0 ←		Total	237.0
3: 8.8 ←			
4: 9.0 ←			
5: 8.8 →			

1: 10.3 ↖		Series	48.0
2: *10.5 ↙		Total	285.0
3: 10.2 →			
4: 8.9 ↑			
5: *10.5 ↖			

<p>5 Shots Sight</p>	<p>1. Series 5 Shots</p>	<p>1: 9.2 ↙ 2: *10.9 ↘ 3: 10.3 ←</p> <p>1: 10.0 ↗ 2: 10.0 ↘ 3: 10.1 ↓ 4: 10.3 ↖ 5: 10.1 ↘</p>
Series 29.0	Series 50.0	
Total 145.0	Total 195.0	

<p>2. Series 5 Shots</p>	<p>3. Series 1 Shots</p>	<p>1: 10.0 ↙ 2: 10.3 ↗ 3: 10.3 ↑ 4: 10.3 ↙ 5: 8.8 ↘</p> <p>1: *10.8 ↖ 2: 10.2 → 3: 8.4 ↓ 4: 8.6 ↓ 5: 9.9 →</p>
Series 48.0	Series 45.0	
Total 243.0	Total 288.0	

<p>1. Series 1 Shots Sh.off</p>	<p>2. Series 1 Shots Sh.off</p>	<p>1: 10.2 ↓</p> <p>1: 10.4 ←</p>
Series 10.0	Series 10.0	
Total 288.0	Total 288.0	

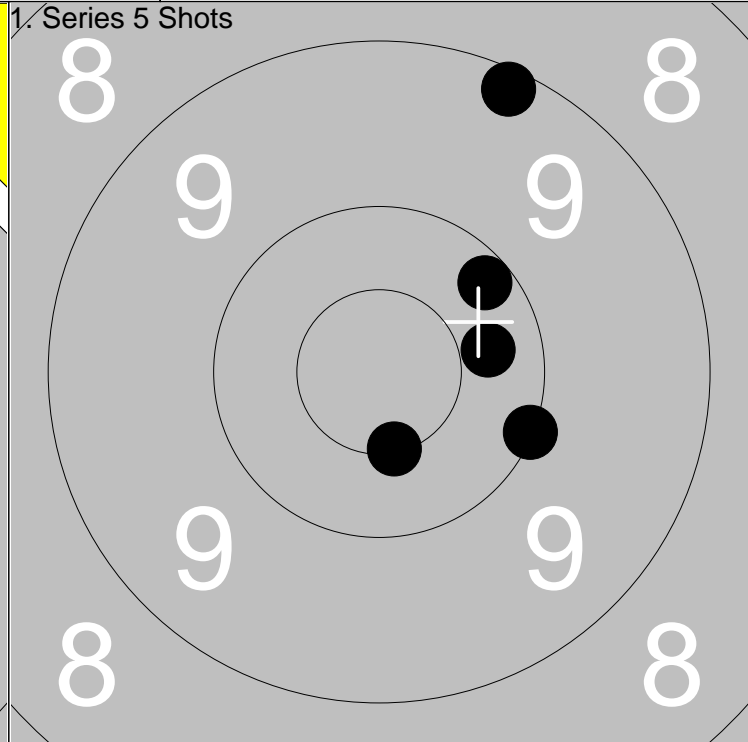
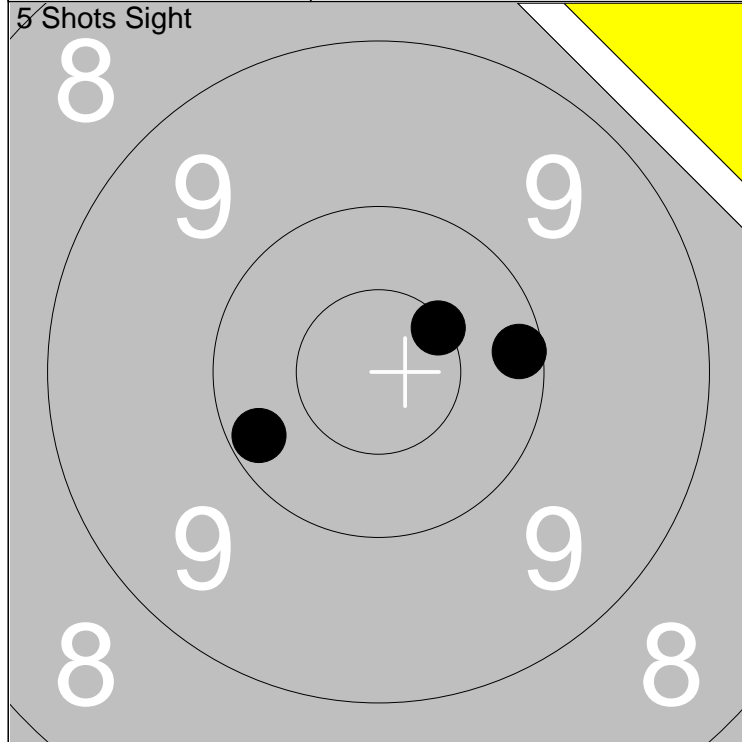

1: 10.2 ↙	Series	30.0
2: *10.5 ↗		
3: 10.2 →		
Total		143.0

1: 9.2 ↗	Series	49.0
2: 10.3 →		
3: *10.5 ↓		
Total		192.0

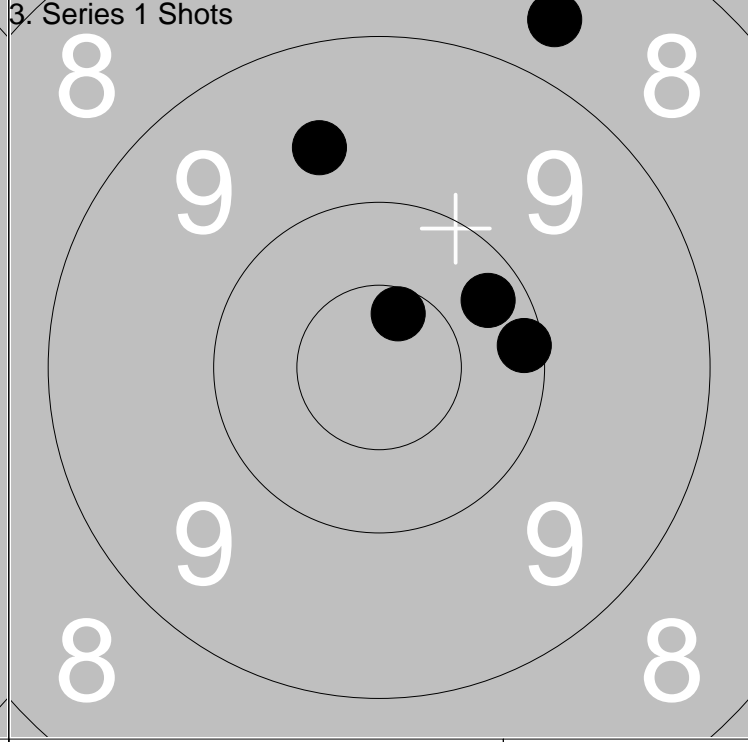
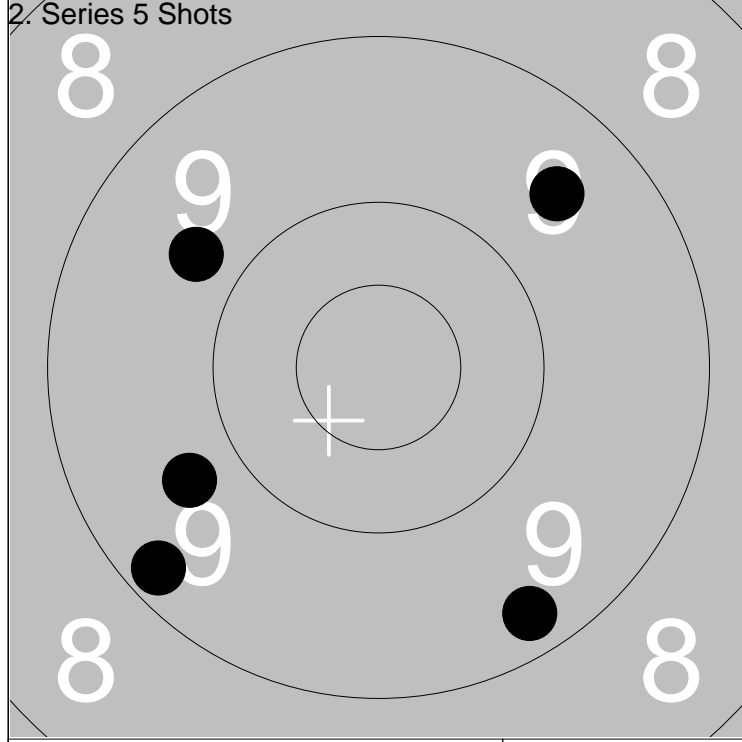

1: 9.7 ↖	Series	45.0
2: 9.2 ↙		
3: 9.7 ↙		
Total		237.0

1: *10.6 ↗	Series	47.0
2: 9.7 ↗		
3: 8.7 ↗		
Total		284.0

<p>5 Shots Sight</p>	<p>1: 9.8 ← 2: *10.7 ↗ 3: 9.7 ↘</p>	<p>1. Series 5 Shots</p>	<p>1: *10.7 → 2: 9.0 ↓ 3: *10.7 ↙ 4: 9.2 ↗ 5: *10.7 ↗</p>
Series 28.0		Series 48.0	
Total 143.0		Total 191.0	

<p>2. Series 5 Shots</p>	<p>1: 10.3 ↓ 2: 9.8 ↓ 3: *10.9 ↗ 4: 9.8 ↘ 5: *10.5 →</p>	<p>3. Series 1 Shots</p>	<p>1: 10.0 → 2: *10.6 ↗ 3: 10.4 ↓ 4: 9.6 ↗ 5: *10.5 ↓</p>
Series 48.0		Series 49.0	
Total 239.0		Total 288.0	

<p>1. Series 1 Shots Sh.off</p>	<p>1: 10.0 ↗</p>	<p>2. Series 1 Shots Sh.off</p>	<p>1: 8.5 ↙</p>
Series 10.0		Series 8.0	
Total 288.0		Total 288.0	

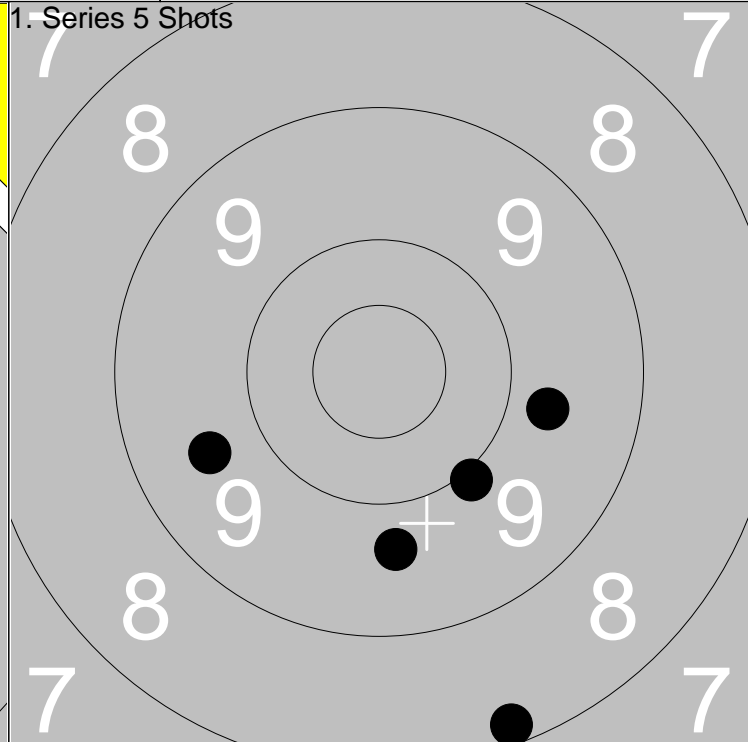
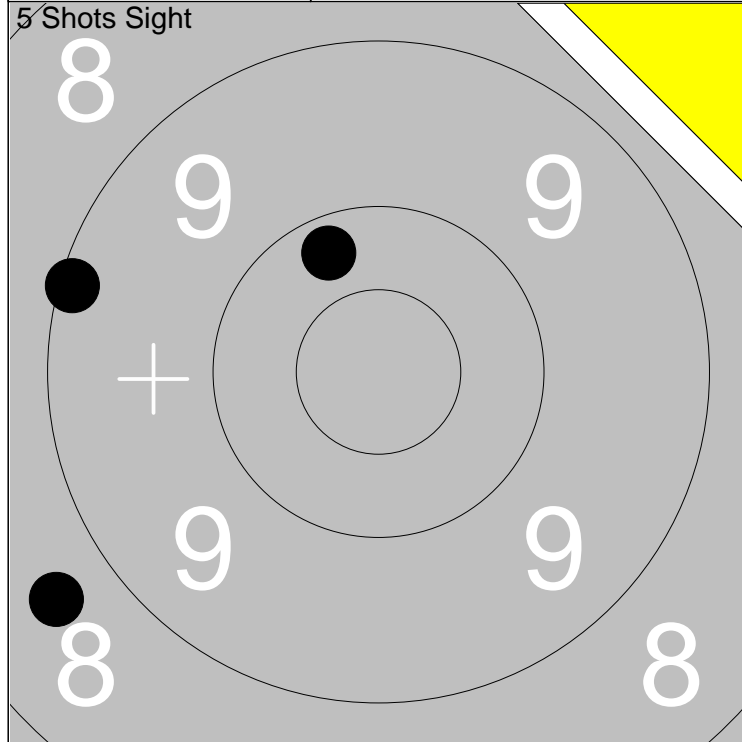

1: 9.1 ←	Series	27.0
2: 10.2 ↗		
3: 8.6 ↙		
Total		143.0

1: 9.6 ↙	Series	45.0
2: 9.7 →		
3: 9.7 ↓		
4: 8.2 ↓		
5: 10.0 ↘		
Total		188.0

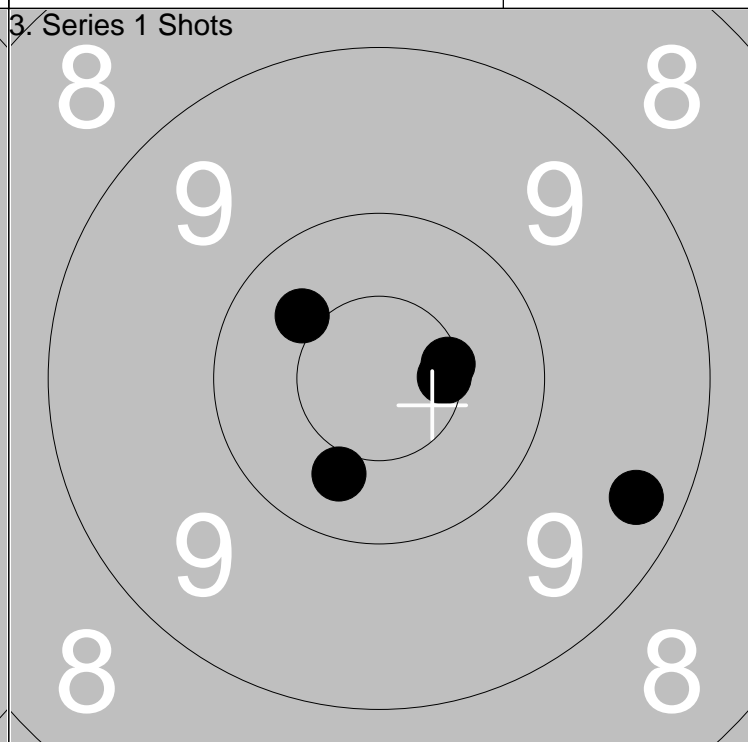
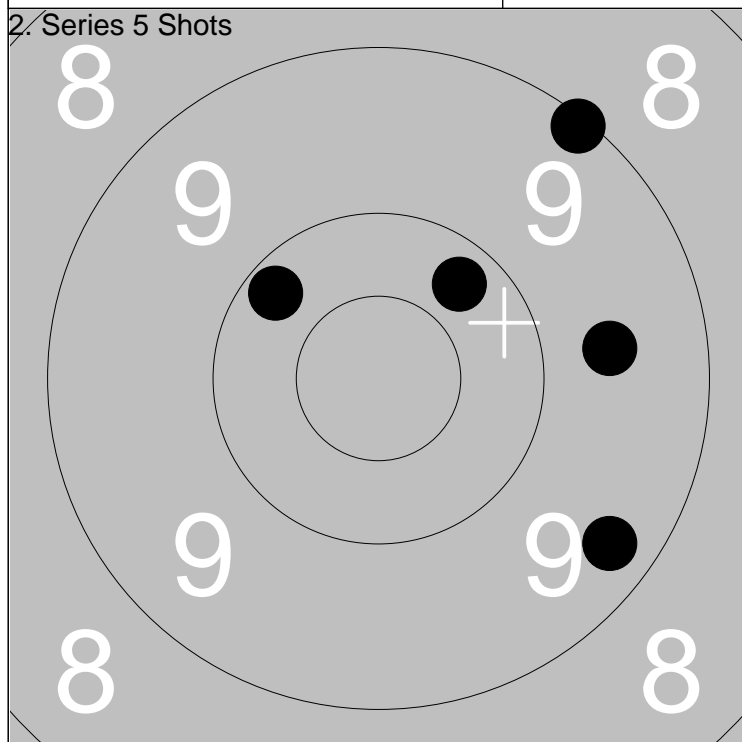

1: 9.1 ↗	Series	47.0
2: 9.6 →		
3: 10.2 ↙		
4: 10.3 ↗		
5: 9.3 ↘		
Total		235.0

1: 10.4 ↓	Series	49.0
2: *10.6 →		
3: 9.3 →		
4: *10.6 →		
5: 10.4 ↙		
Total		284.0

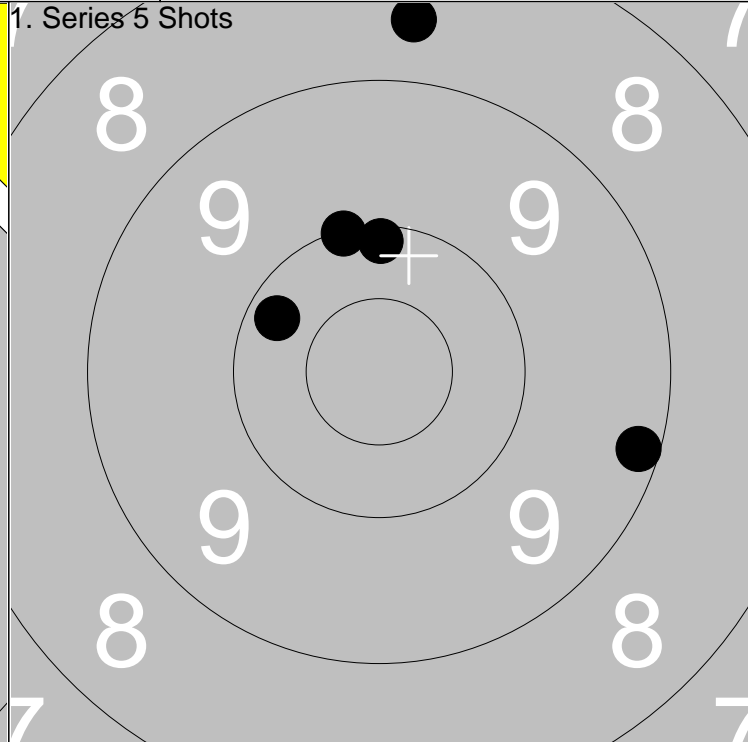
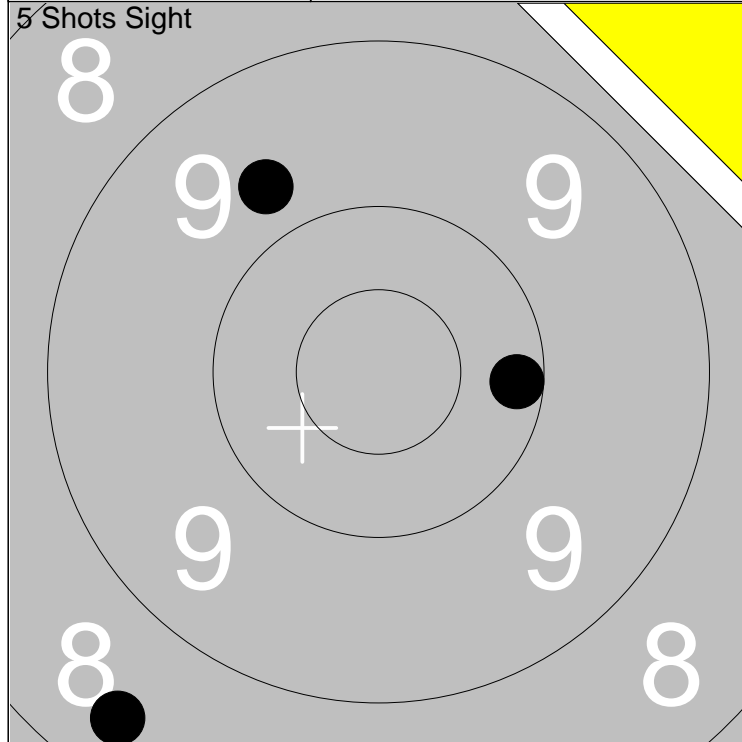

1: 8.4 ↙	Series	27.0
2: 9.7 ↖		
3: 10.2 →		
Total		142.0

1: 9.2 →	Series	47.0
2: 10.1 ↑		
3: 8.6 ↑		
4: 10.2 ↖		
5: 10.0 ↑		
Total		189.0

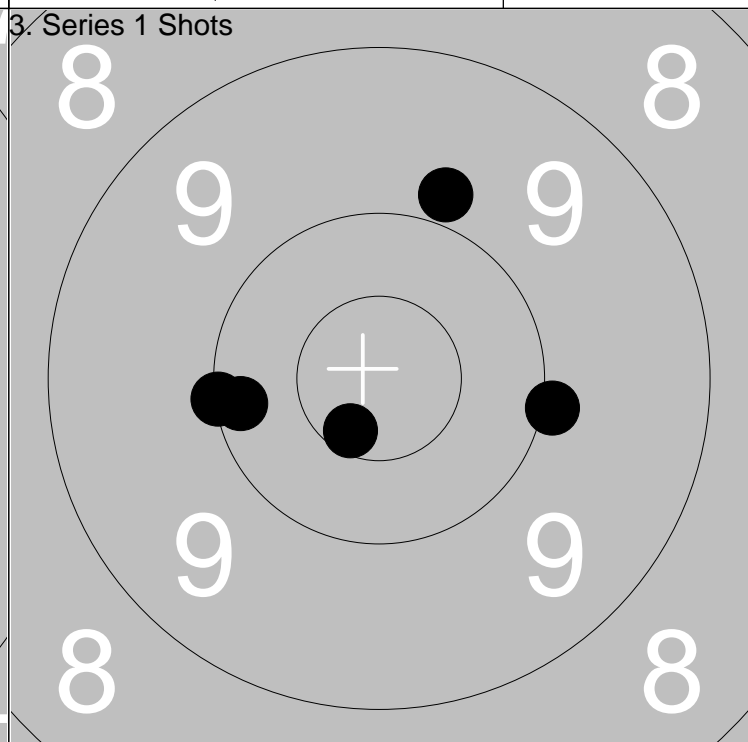
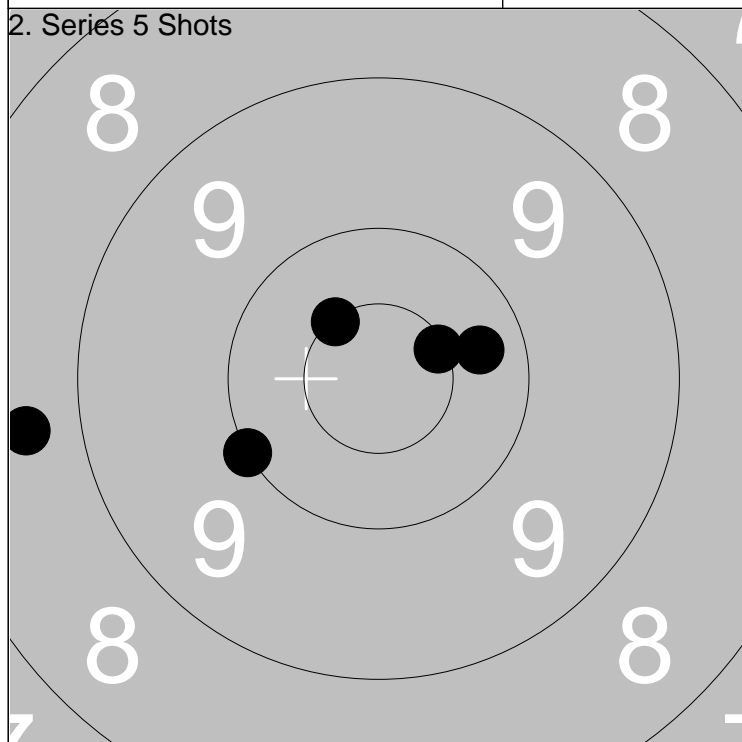

1: 10.3 →	Series	48.0
2: *10.5 ↖		
3: 8.7 ←		
4: 10.0 ↖		
5: *10.5 →		
Total		237.0

1: 10.0 →	Series	49.0
2: *10.6 ↙		
3: 9.8 ↑		
4: 10.0 ←		
5: 10.2 ←		
Total		286.0

Relay 5	Lane 10	Lars Evaldsson	
-------------------	-------------------	-----------------------	--

300m	Göteborg	B	Vs
------	----------	---	----

2013-07-07	Tavelträffen A 2013	Ramselefors SKF
------------	---------------------	-----------------

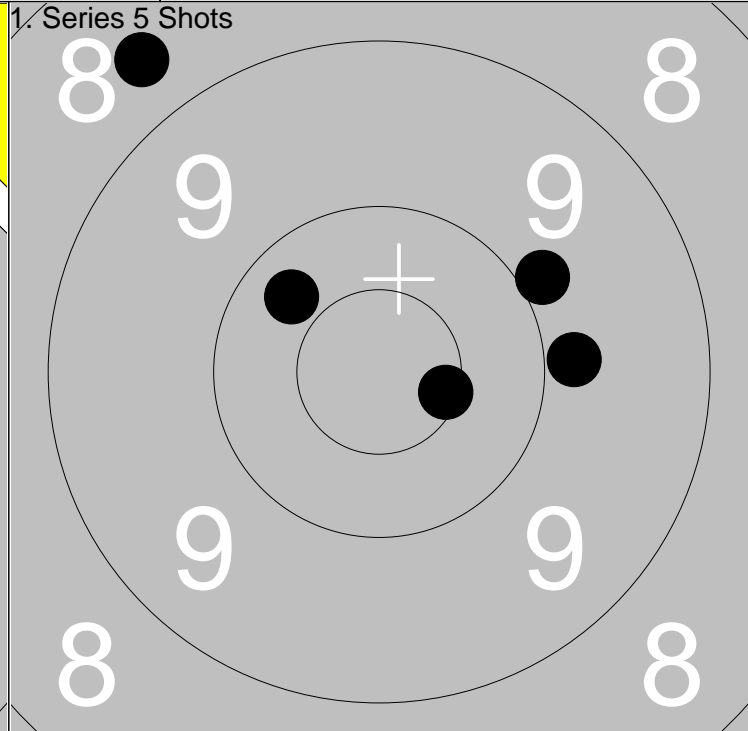
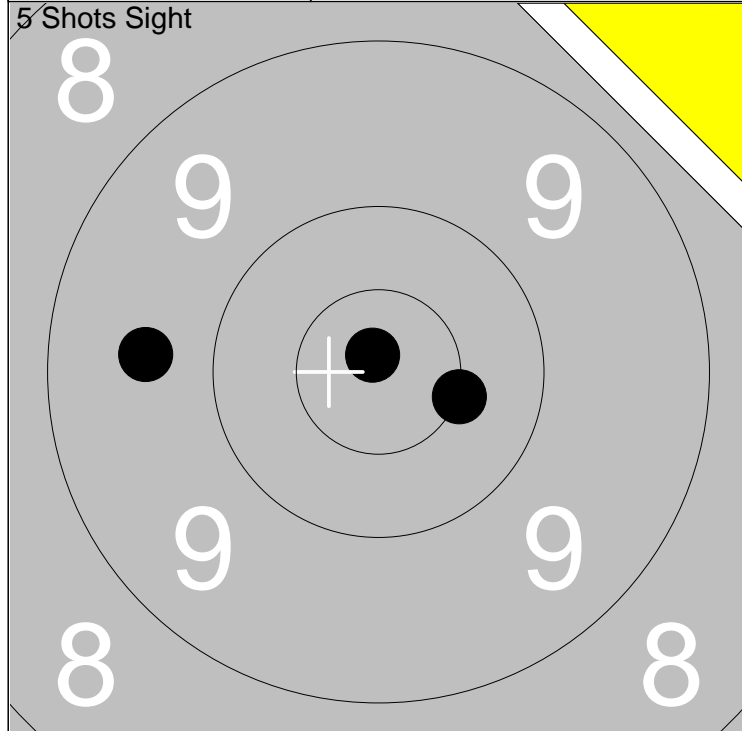

1: 9.6 ←	Series	29.0
2: *10.9 ↗		
3: *10.5 →		
Total		142.0

1: 8.7 ↖	Series	46.0
2: 10.3 ↖		
3: 9.9 →		
4: *10.6 →		
5: 9.9 ↗		
Total		188.0

1: 8.7 ↖	Series	46.0
2: 10.3 ↖		
3: 9.9 →		
4: *10.6 →		
5: 9.9 ↗		
Total		188.0

1: 8.7 ↖	Series	46.0
2: 10.3 ↖		
3: 9.9 →		
4: *10.6 →		
5: 9.9 ↗		
Total		188.0

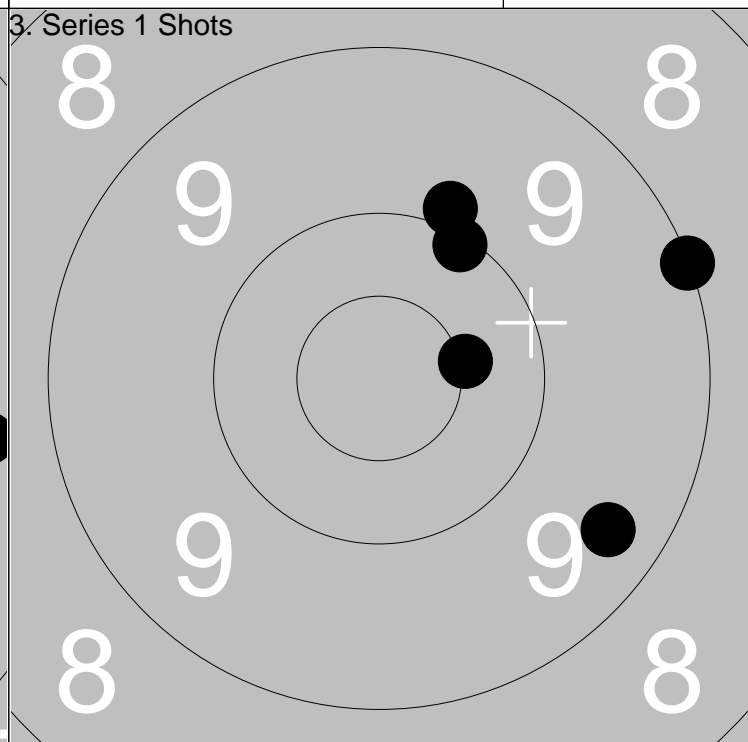
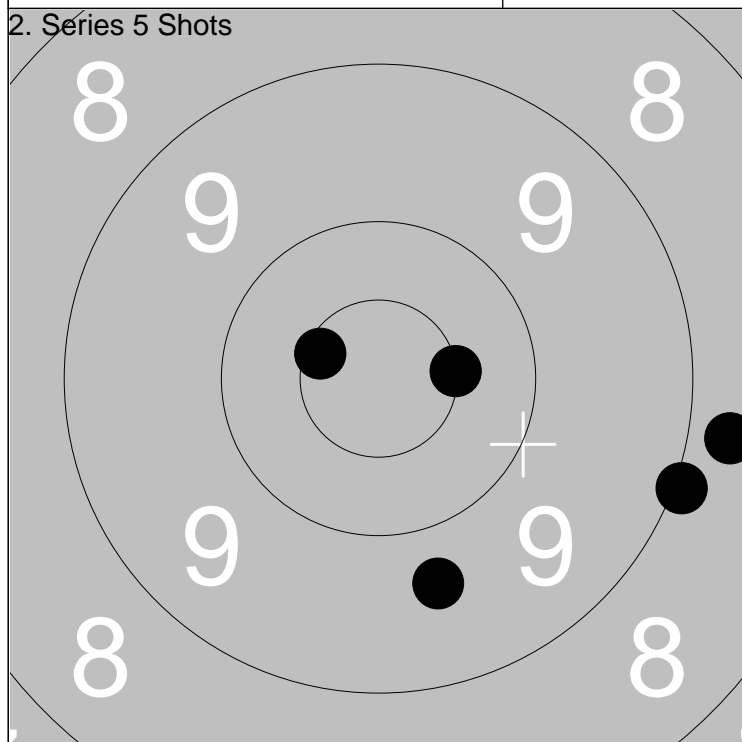

1: *10.5 →	Series	46.0
2: 8.8 →		
3: *10.6 ↖		
4: 9.7 ↓		
5: 9.0 →		
Total		234.0

1: 9.0 →	Series	47.0
2: 10.1 ↗		
3: 9.9 ↗		
4: *10.5 →		
5: 9.4 ↘		
Total		281.0

1: 9.0 →	Series	47.0
2: 10.1 ↗		
3: 9.9 ↗		
4: *10.5 →		
5: 9.4 ↘		
Total		281.0

1: 9.0 →	Series	47.0
2: 10.1 ↗		
3: 9.9 ↗		
4: *10.5 →		
5: 9.4 ↘		
Total		281.0

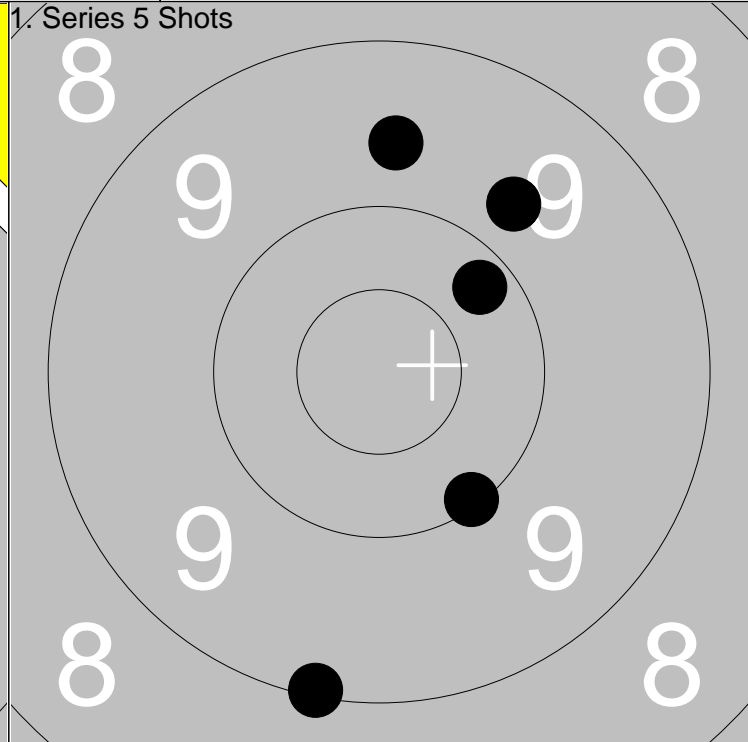
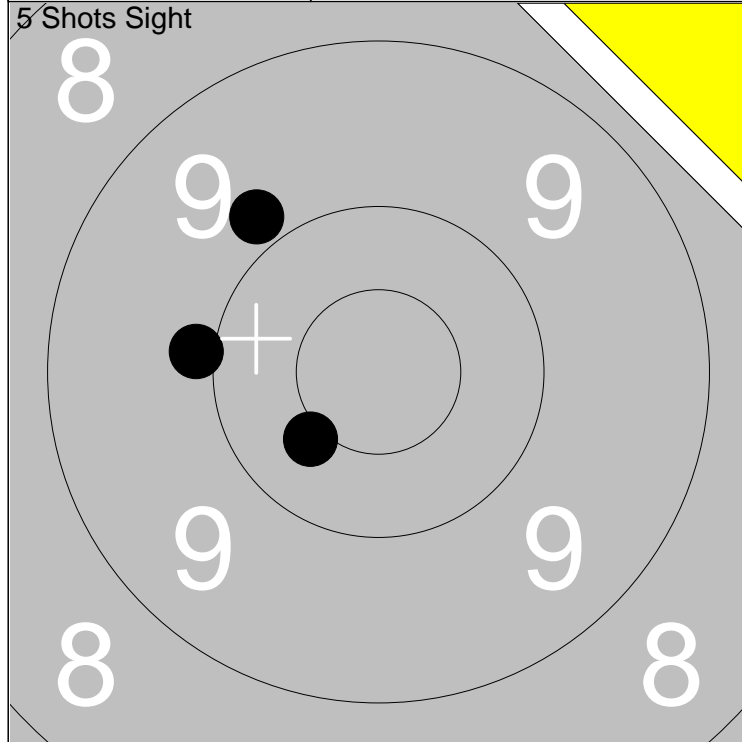

1: 9.9 ←	Series 28.0
2: 10.4 ↙	
3: 9.8 ↖	
Total 142.0	

1: 10.2 ↗	Series 47.0
2: 9.1 ↓	
3: 9.7 ↗	
4: 9.6 ↑	
5: 10.1 ↘	
Total 189.0	

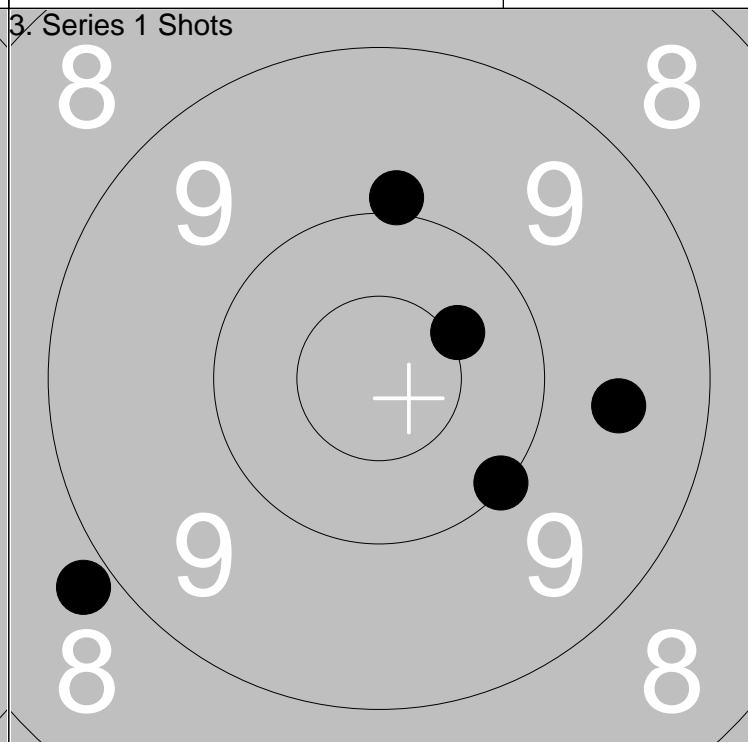
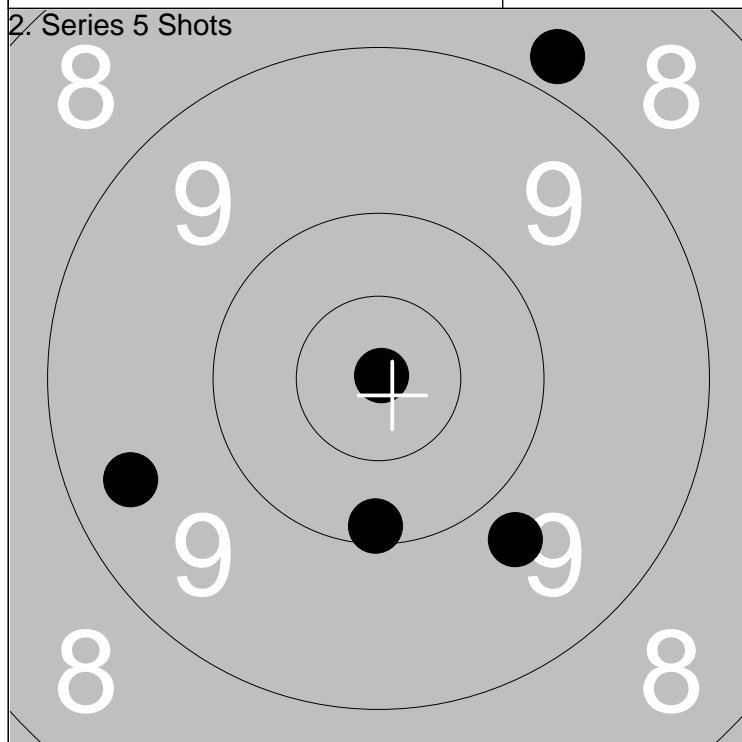

1: 10.1 ↓	Series 46.0
2: 9.8 ↘	
3: 9.4 ←	
4: *10.9 ↗	
5: 8.8 ↗	
Total 235.0	

1: 9.6 →	Series 46.0
2: 10.1 ↘	
3: *10.4 ↗	
4: 8.8 ←	
5: 9.9 ↑	
Total 281.0	

Relay 5	Lane 12	Jan Wallerström		
-------------------	-------------------	------------------------	--	--

300m	Ununge	B	St
------	--------	---	----

2013-07-07	Tavelträffen A 2013	Ramselefors SKF
------------	---------------------	-----------------

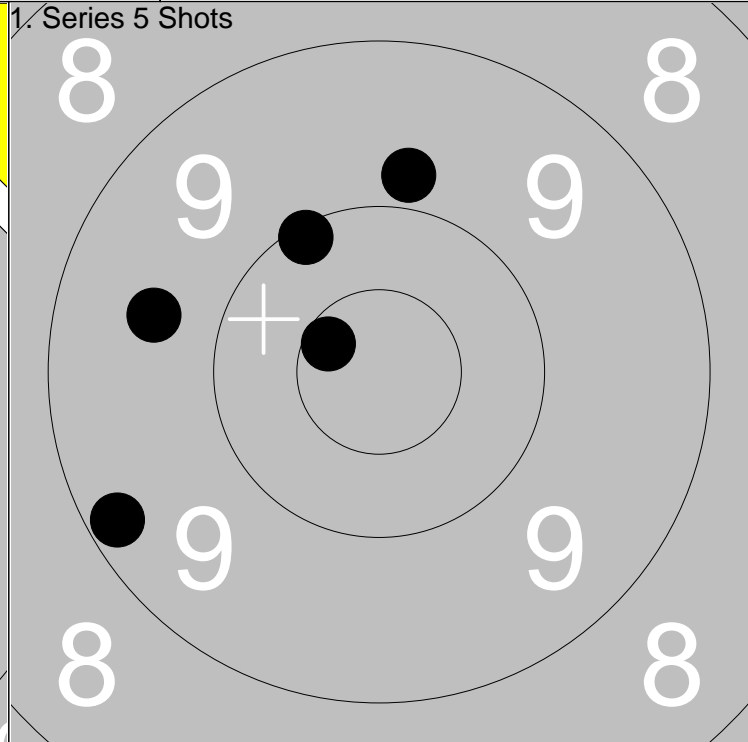
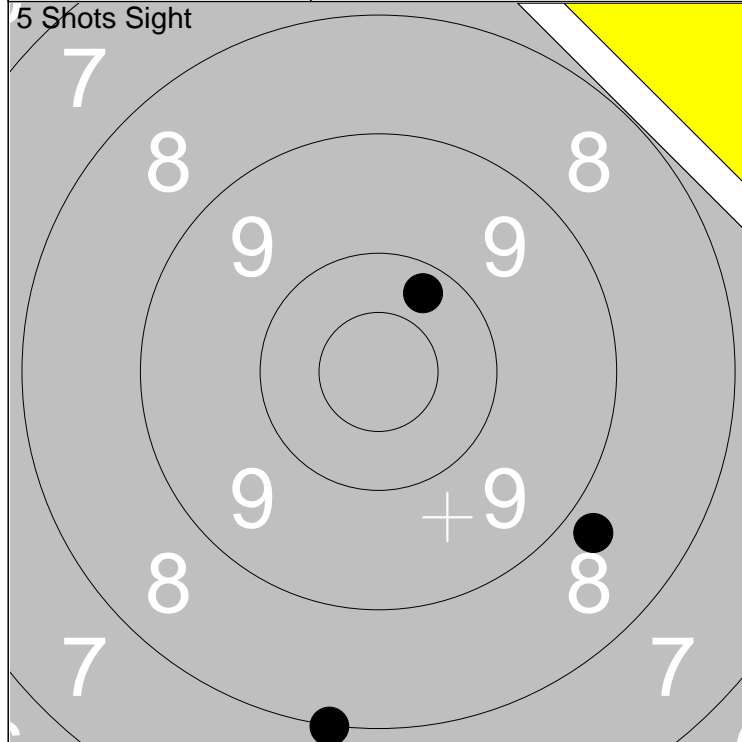

1: 8.0 ↓	Series	26.0
2: 8.8 ↘		
3: 10.2 ↗		
Total		141.0

1: 9.6 ←	Series	47.0
2: 9.8 ↑		
3: 10.1 ↖		
Total		188.0

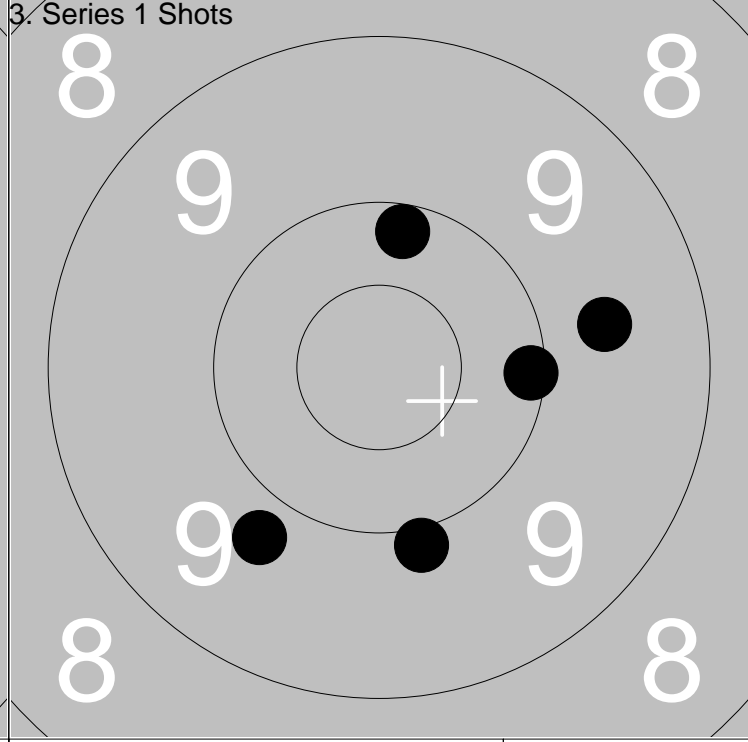
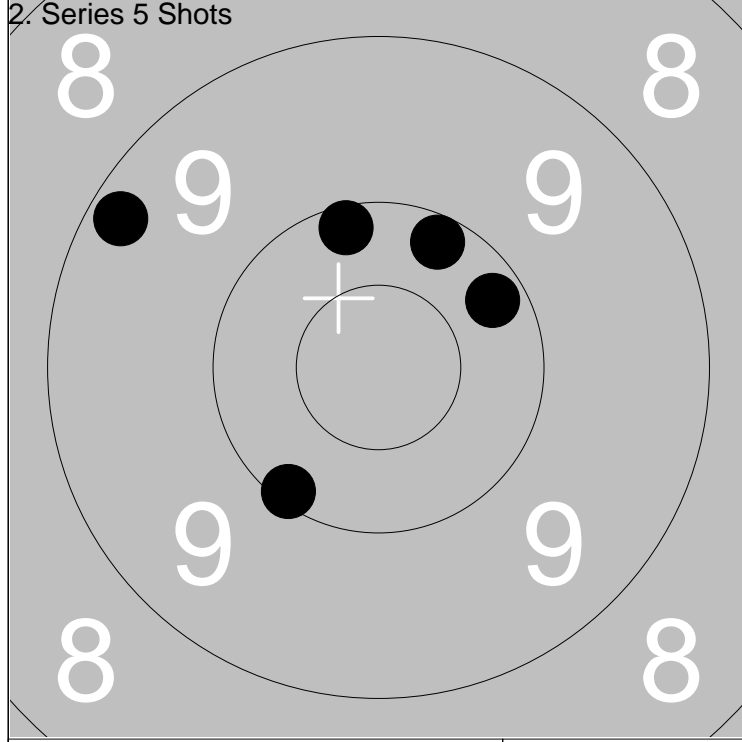

1: 10.2 ↗	Series	49.0
2: 10.1 ↘		
3: 10.2 ↗		
Total		237.0

1: 10.2 ↑	Series	47.0
2: 9.6 →		
3: 9.8 ↘		
Total		284.0

Relay	Lane	Alf Edin	
5	13		

300m	Ale	B	No
------	-----	---	----

2013-07-07	Tavelträffen A 2013	Ramselefors SKF
------------	---------------------	-----------------

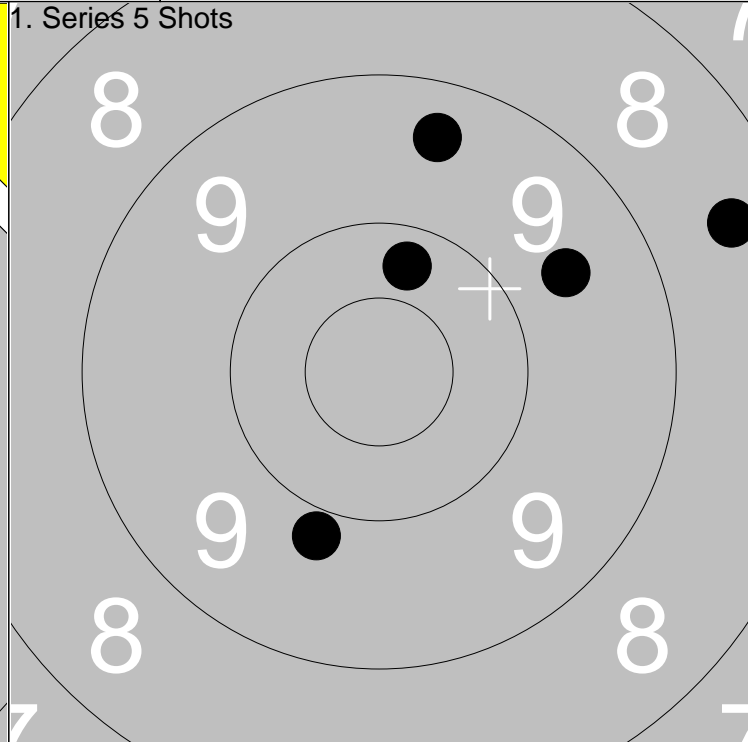
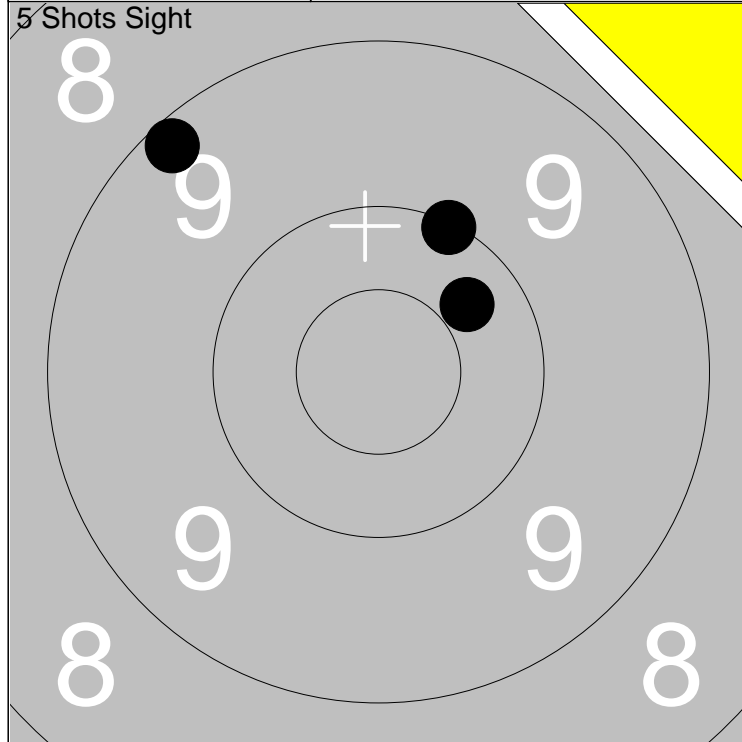

1: 10.3 ↗
2: 10.1 ↑
3: 9.2 ↖

Series	29.0
Total	141.0

1: 8.5 ↗
2: 9.6 ↗
3: 9.4 ↑
4: 10.3 ↑
5: 9.8 ↓

Series	45.0
Total	186.0

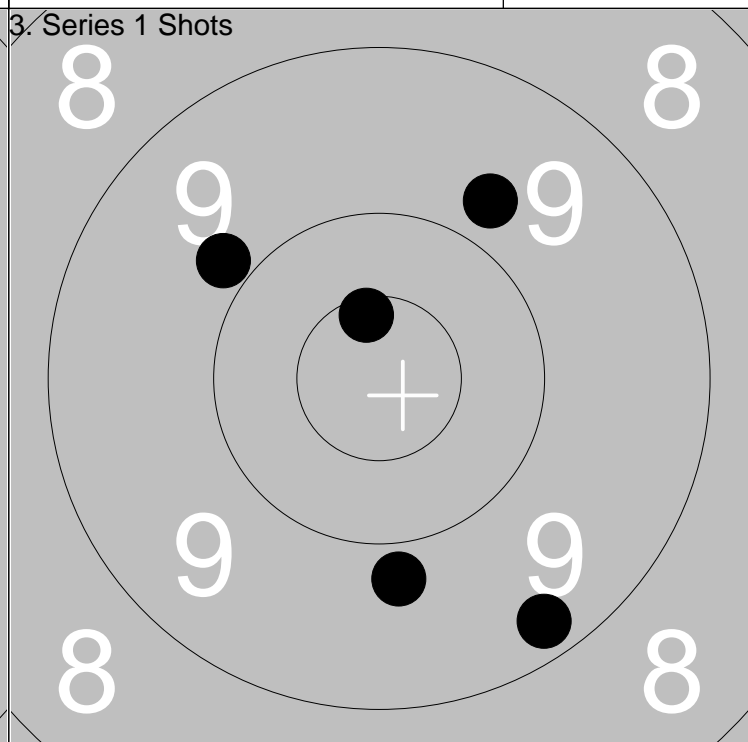
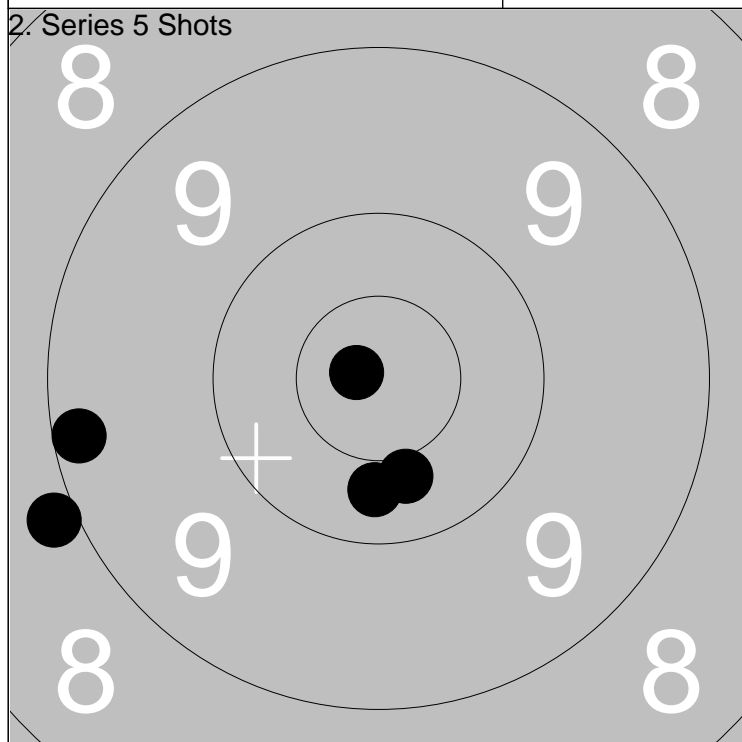

1: *10.8 ↖
2: 10.4 ↓
3: 10.3 ↓
4: 8.9 ←
5: 9.2 ←

Series	47.0
Total	233.0

1: 9.8 ↗
2: 9.8 ↖
3: 9.3 ↓
4: 9.8 ↓
5: *10.6 ↑

Series	46.0
Total	279.0

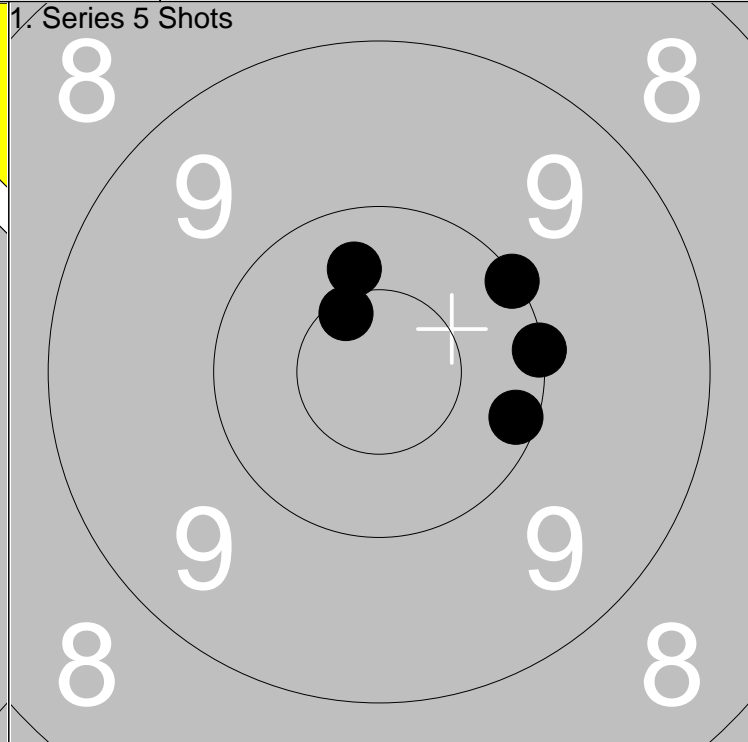
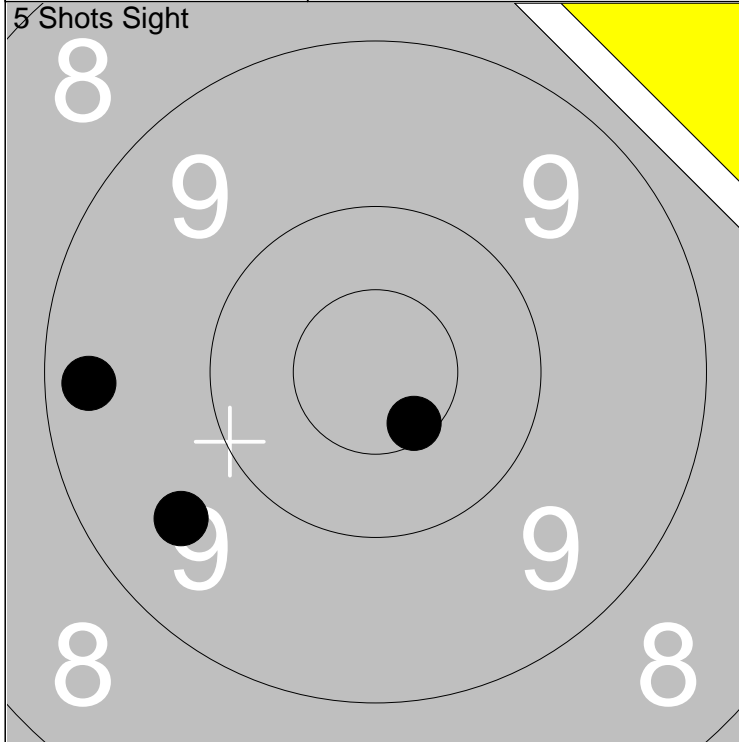

1: 9.3 ←	Series	28.0
2: 9.6 ↙		
3: *10.6 ↘		
Total		141.0

1: *10.6 ↖	Series	50.0
2: 10.0 →		
3: 10.1 →		
4: 10.0 ↗		
5: 10.4 ↑		
Total		191.0

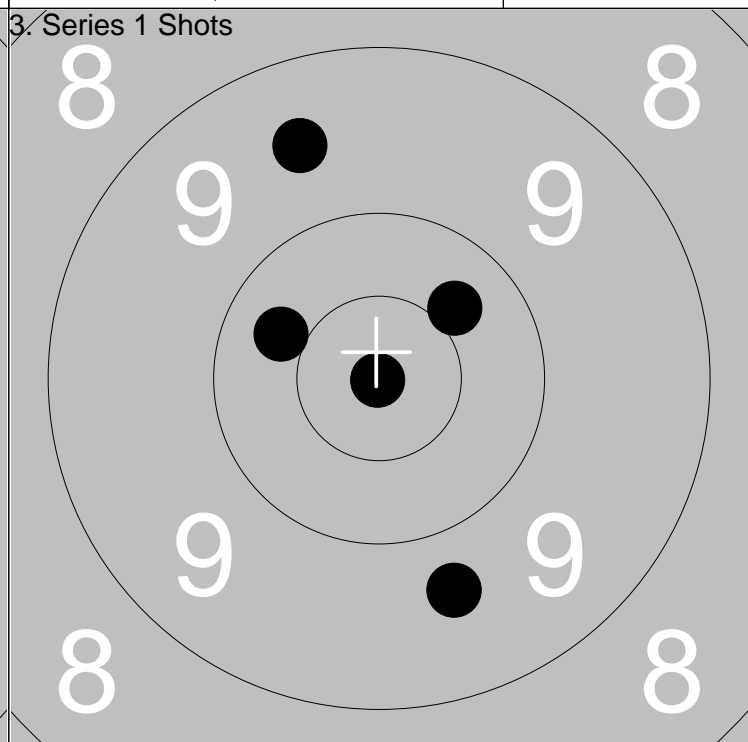
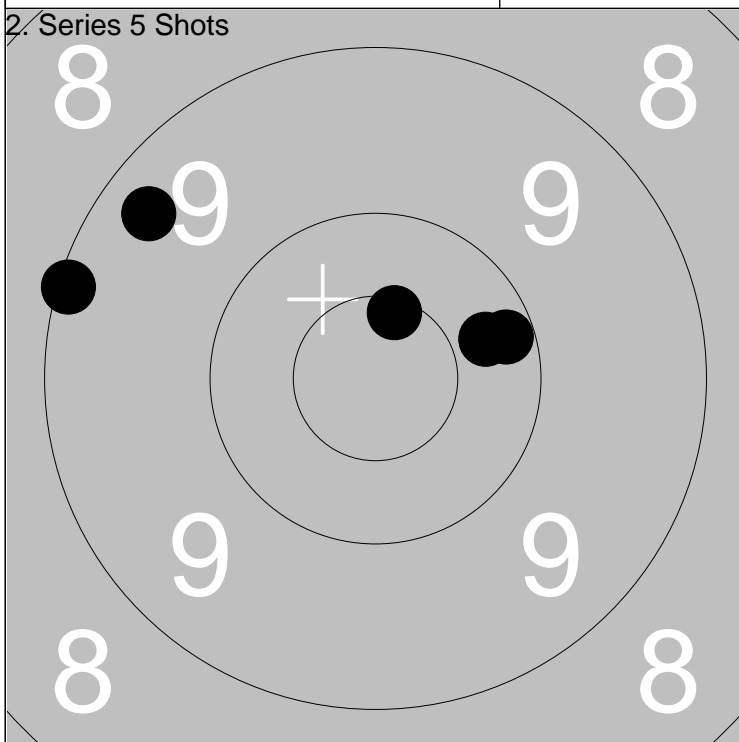

1: 9.3 ↖	Series	48.0
2: 10.2 →		
3: *10.6 ↑		
4: 9.1 ←		
5: 10.3 →		
Total		239.0

1: 10.4 ↗	Series	48.0
2: 10.3 ↖		
3: *10.9 ↘		
4: 9.5 ↑		
5: 9.7 ↘		
Total		287.0

Relay 5	Lane 15	Linda Bergman		
-------------------	-------------------	----------------------	--	--

300m	Ununge	B	St
------	--------	---	----

2013-07-07	Tavelträffen A 2013	Ramselefors SKF
------------	---------------------	-----------------

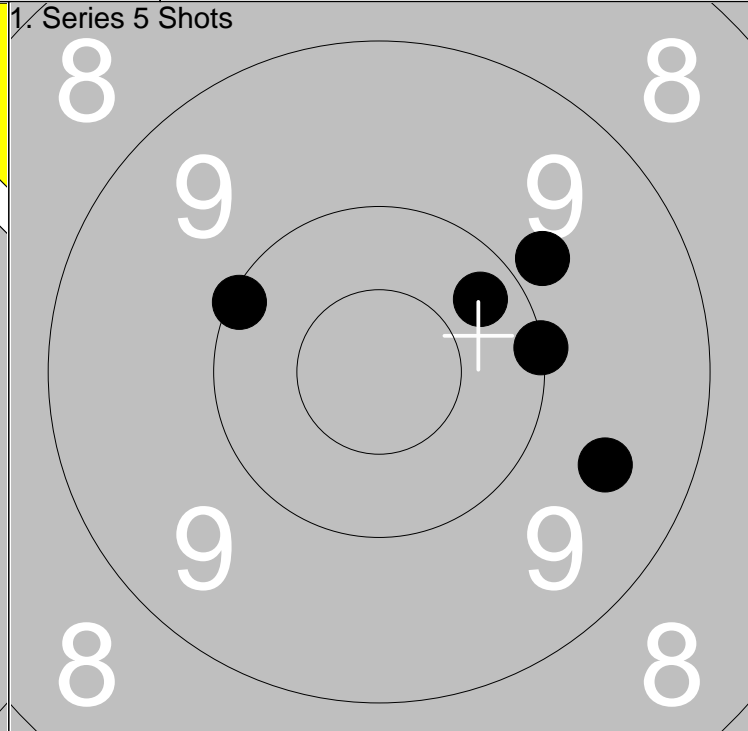
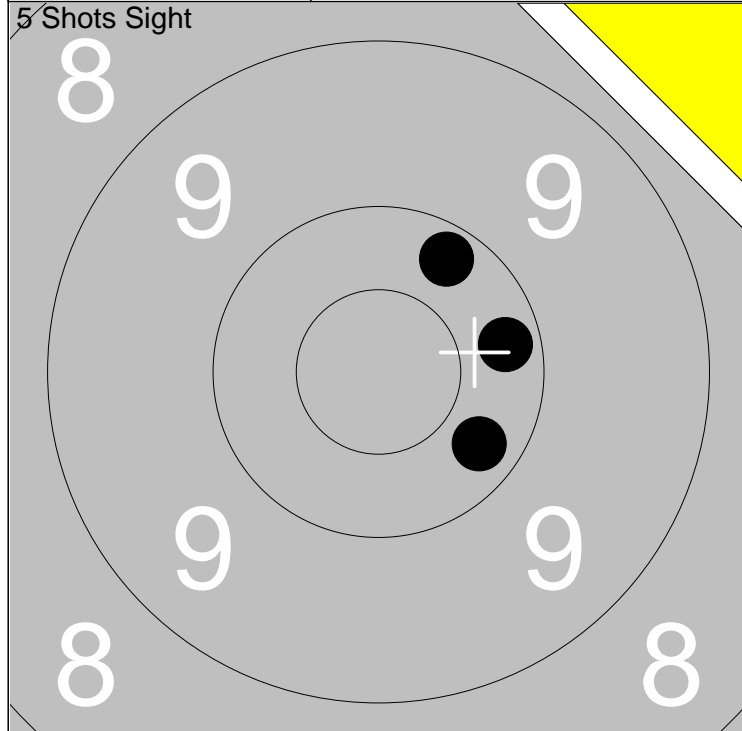

1: 10.2 ↗	Series	30.0
2: 10.2 →		
3: 10.3 ↘		
Total		141.0

1: 10.1 ↖	Series	48.0
2: 9.8 ↗		
3: 10.0 →		
4: 10.3 ↗		
5: 9.6 ↘		
Total		189.0

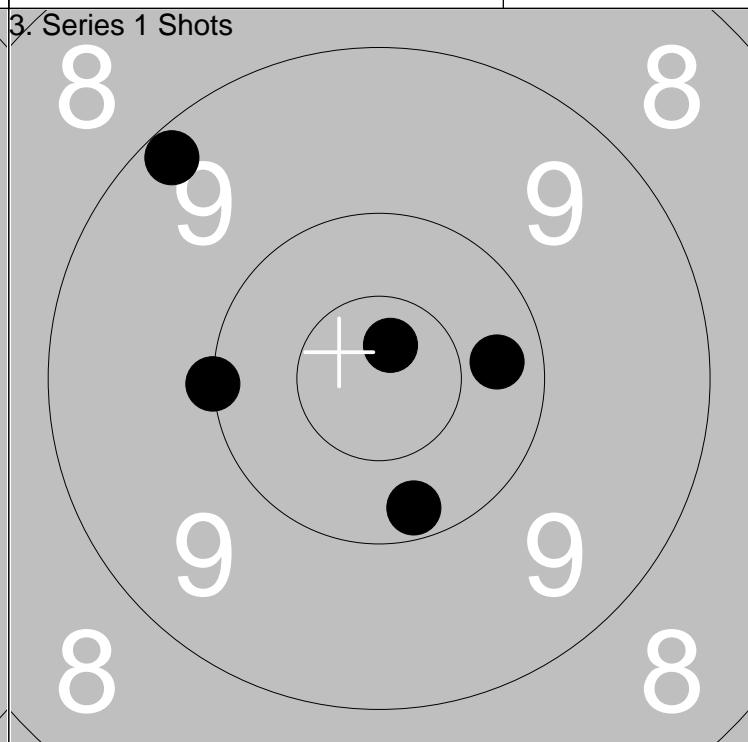
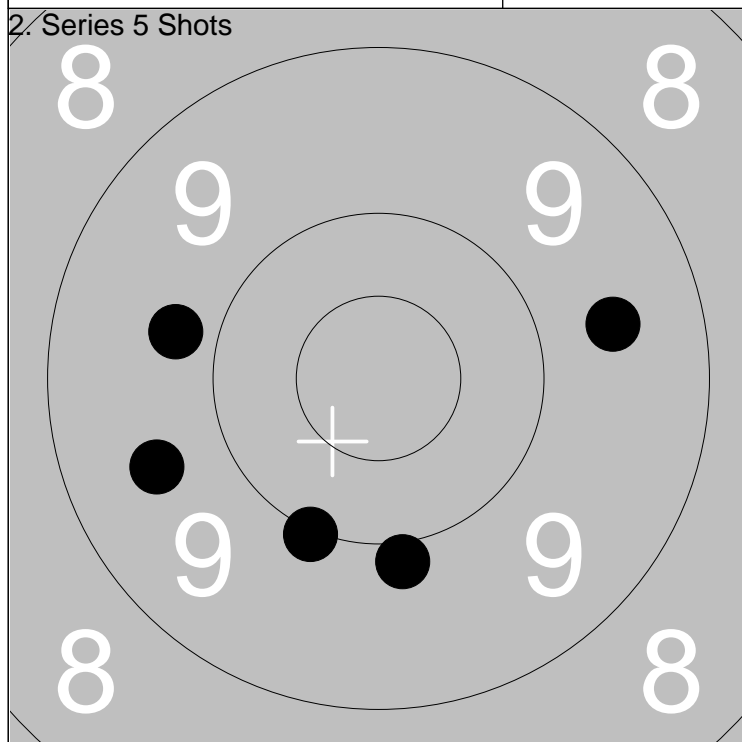

1: 9.9 ↓	Series	46.0
2: 9.6 →		
3: 9.6 ←		
4: 9.8 ←		
5: 10.0 ↓		
Total		235.0

1: 10.3 →	Series	49.0
2: 10.0 ←		
3: *10.8 ↗		
4: 9.2 ↖		
5: 10.2 ↓		
Total		284.0

Relay	Lane	Stefan Jonasson	
5	16		

300m	Hogdal	B	Jä
------	--------	---	----

2013-07-07	Tavelträffen A 2013	Ramselefors SKF
------------	---------------------	-----------------

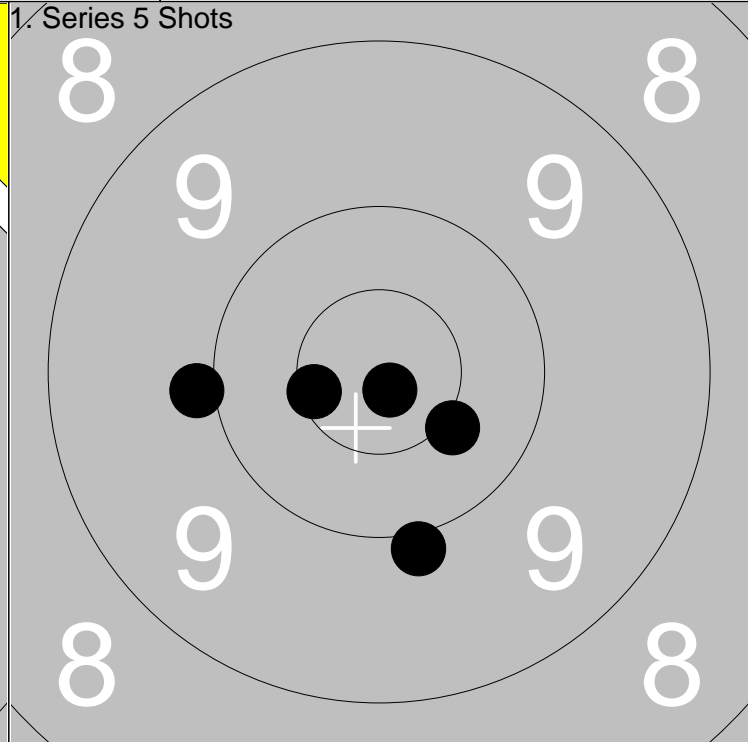
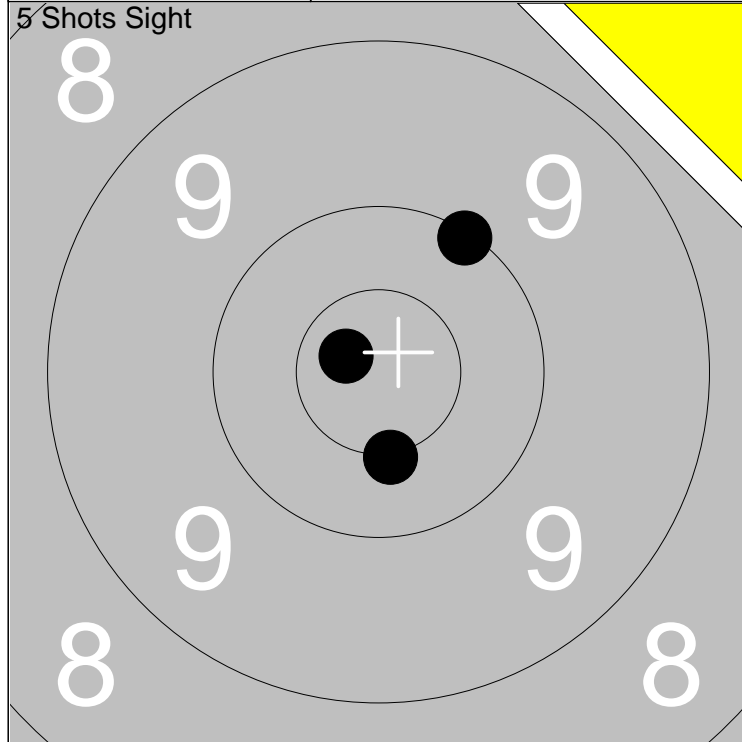

1: *10.5 ↓	Series	30.0
2: *10.7 ↖		
3: 10.1 ↗		
Total		141.0

1: 9.9 ←	Series	48.0
2: *10.6 ↖		
3: *10.8 ↓		
4: *10.4 ↘		
5: 9.9 ↓		
Total		189.0

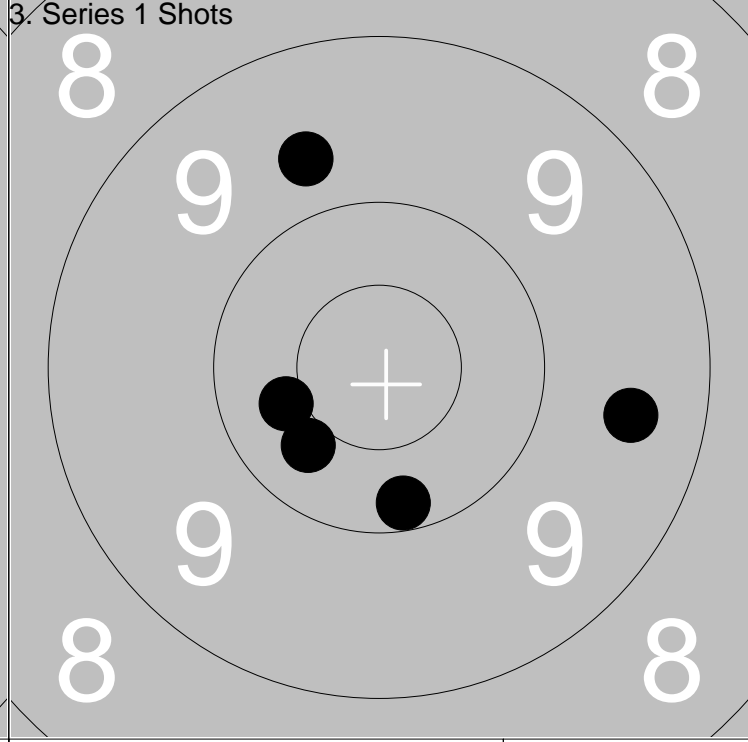
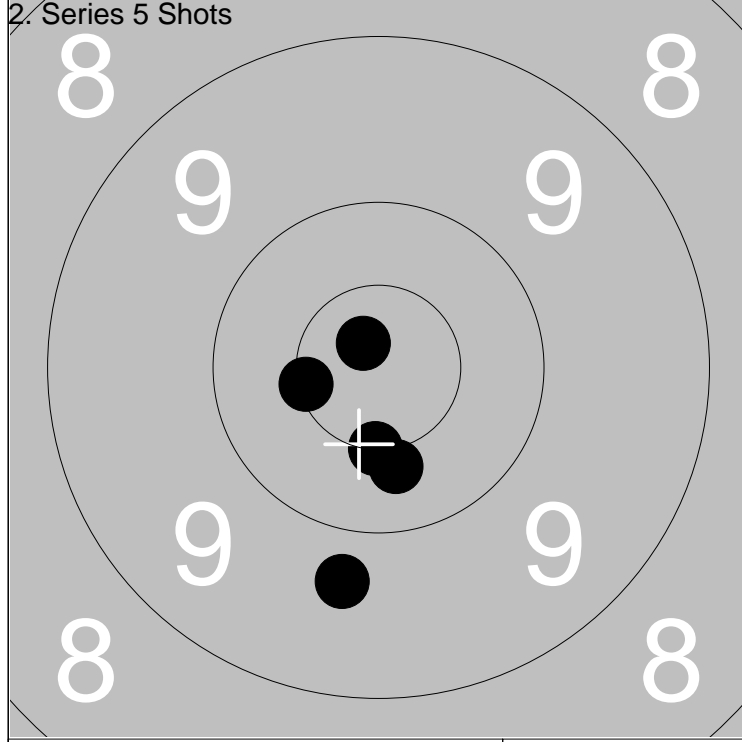

1: 10.4 ↓	Series	49.0
2: *10.5 ↓		
3: 9.7 ↓		
4: *10.5 ↖		
5: *10.8 ↖		
Total		238.0

1: 9.5 →	Series	48.0
2: 9.7 ↗		
3: 10.4 ↖		
4: 10.2 ↓		
5: 10.4 ↖		
Total		286.0

Relay 5	Lane 18	Johan Nilsson		
-------------------	-------------------	----------------------	--	--

300m	Ramselefors	B	Vb
------	-------------	---	----

2013-07-07	Tavelträffen A 2013	Ramselefors SKF	
------------	---------------------	-----------------	--

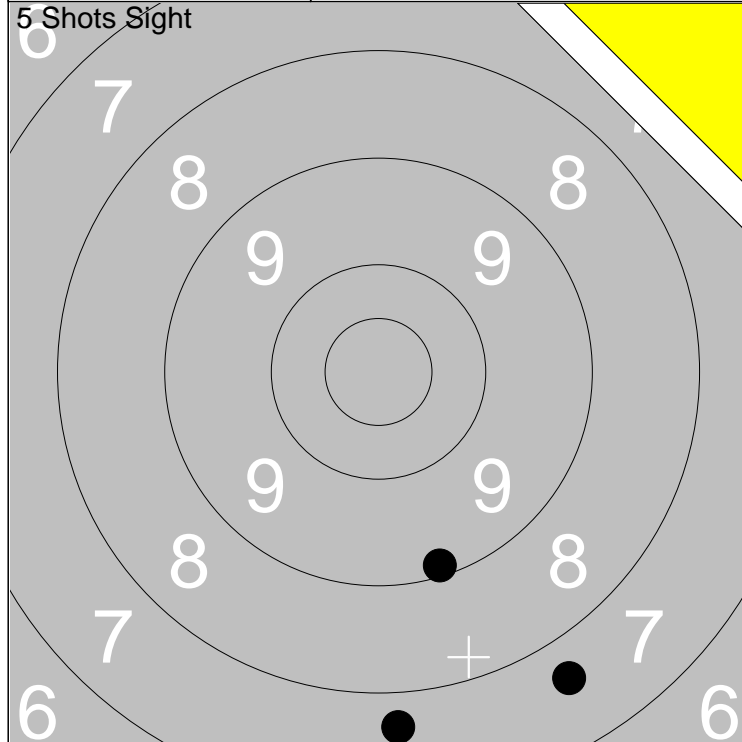

1: 9.1 ↓	Series	23.0
2: 7.7 ↓		
3: 7.7 ↓		
Total		140.0

1: 8.6 ↙	Series	46.0
2: 9.3 ↓		
3: 9.3 ↓		
4: *10.6 ↗		
5: 10.1 ↗		
Total		186.0

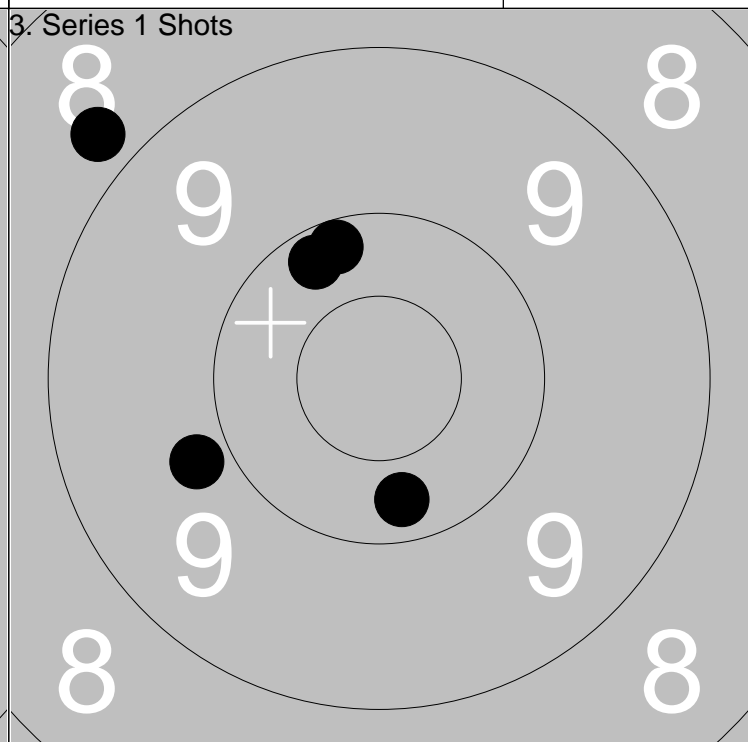
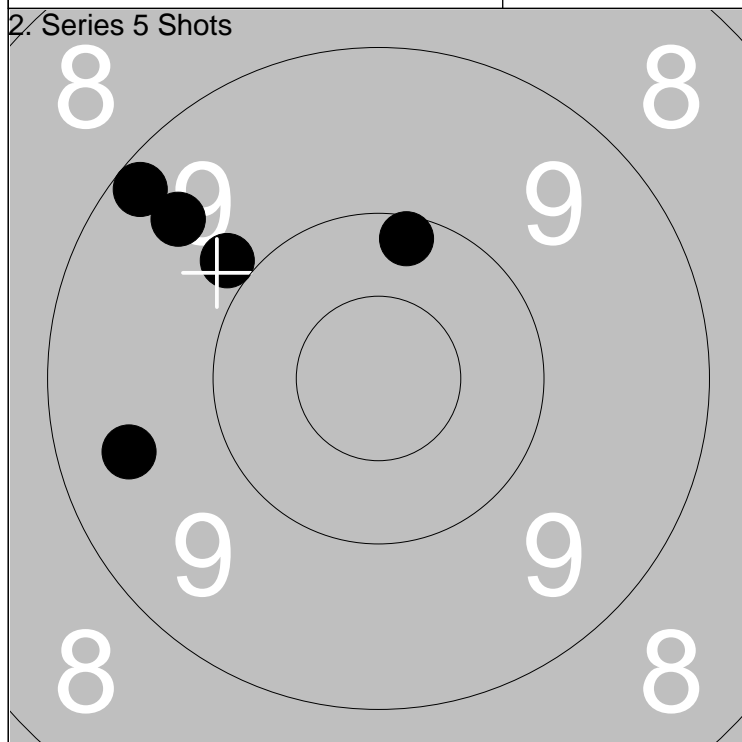

1: 10.2 ↑	Series	46.0
2: 9.5 ↙		
3: 9.9 ↗		
4: 9.2 ↗		
5: 9.5 ↗		
Total		232.0

1: 10.2 ↑	Series	47.0
2: 8.8 ↙		
3: 10.3 ↓		
4: 9.8 ↙		
5: 10.2 ↗		
Total		279.0

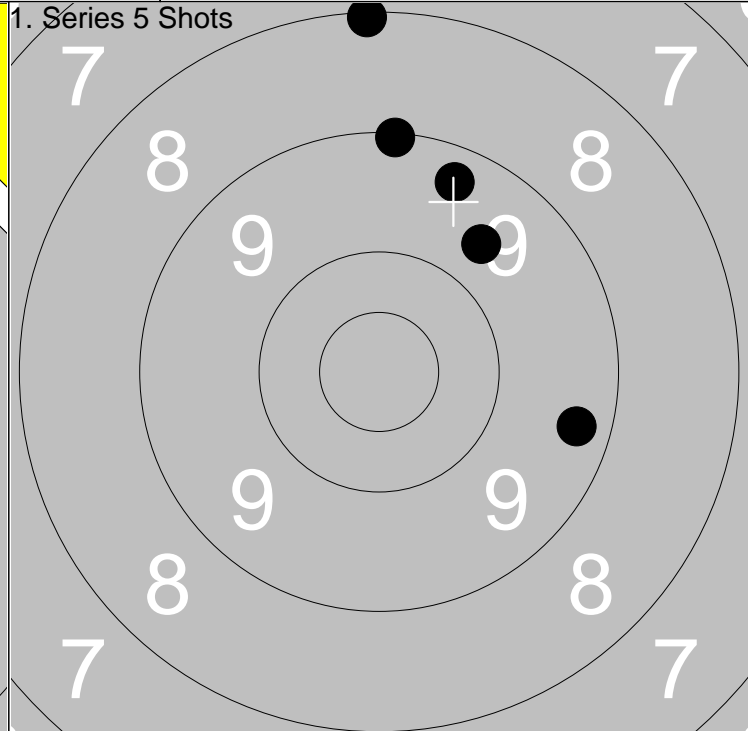
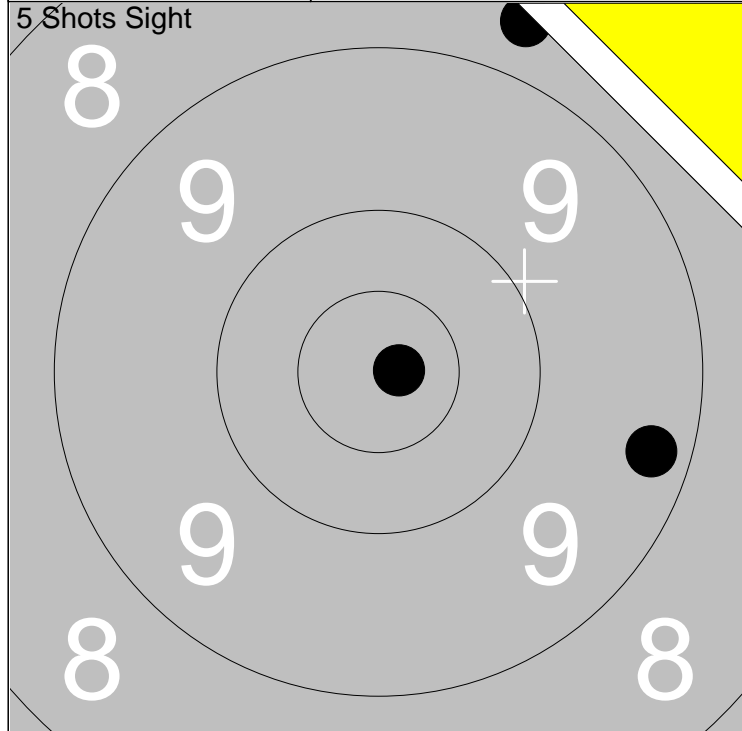

1: 8.7 ↗	Series 27.0
2: *10.8 →	
3: 9.3 →	
Total 140.0	

1: 8.1 ↗	Series 44.0
2: 9.3 ↗	
3: 9.3 →	
4: 9.1 ↗	
5: 9.7 ↗	
Total 184.0	

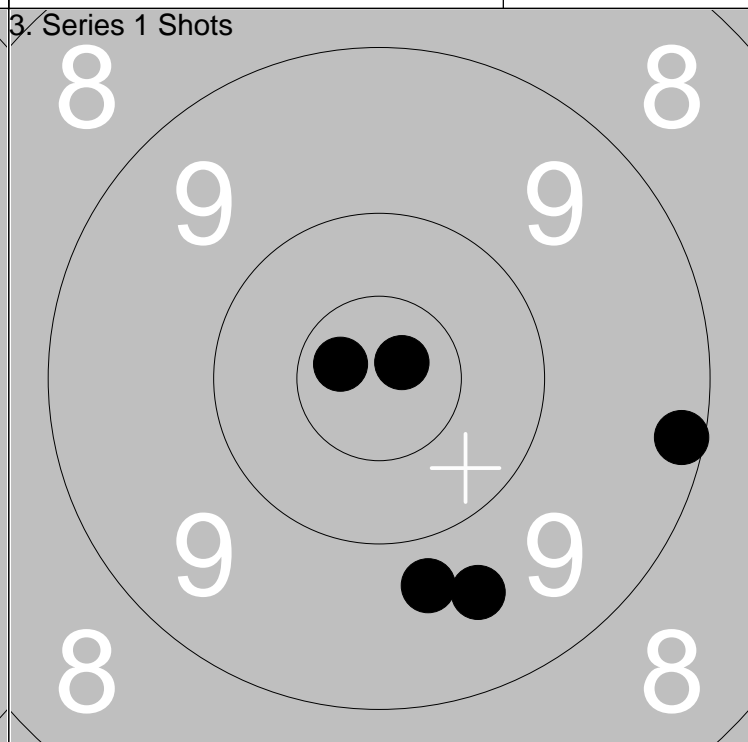
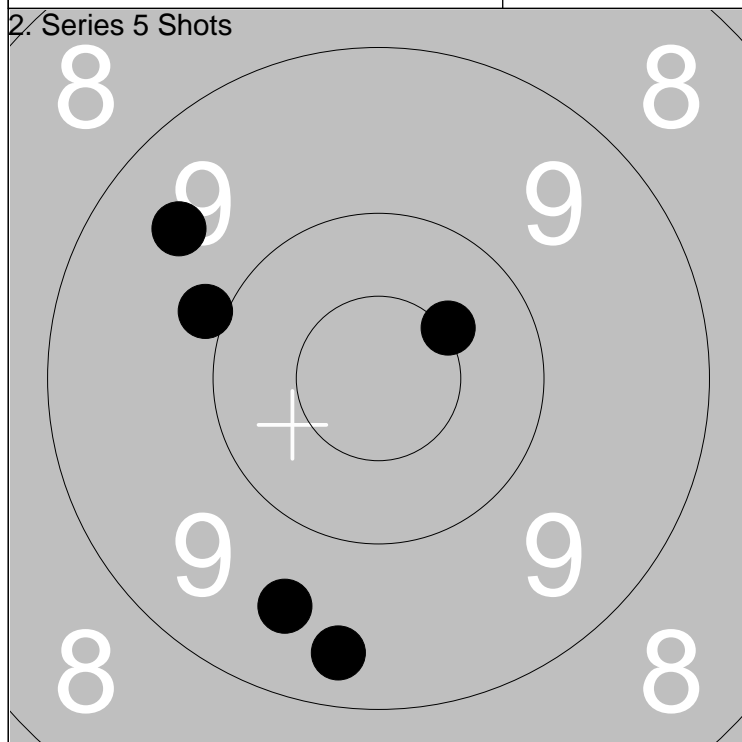

1: 9.9 ↖	Series 46.0
2: 9.5 ↖	
3: *10.5 ↗	
4: 9.5 ↓	
5: 9.4 ↓	
Total 230.0	

1: *10.8 ↗	Series 47.0
2: *10.7 ↖	
3: 9.2 →	
4: 9.6 ↓	
5: 9.7 ↓	
Total 277.0	

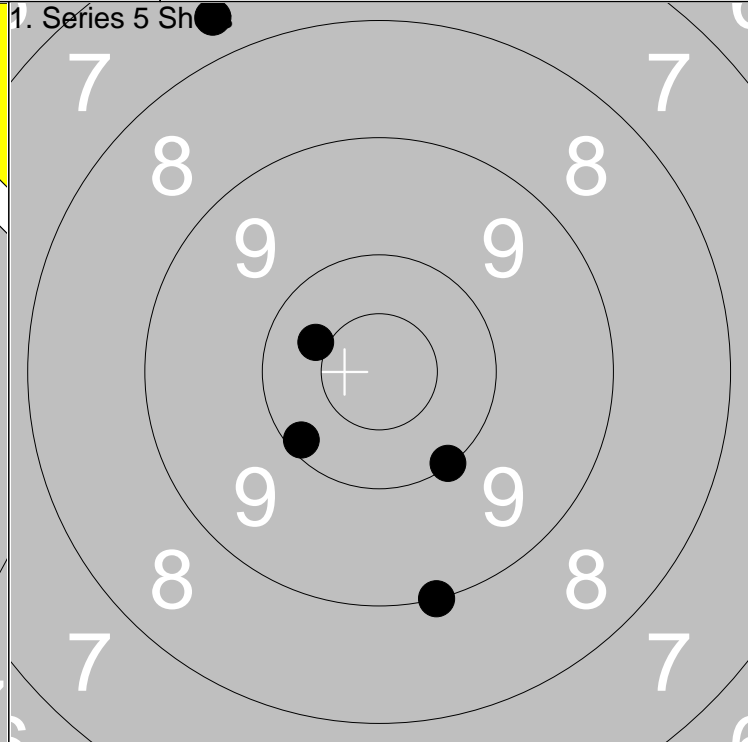
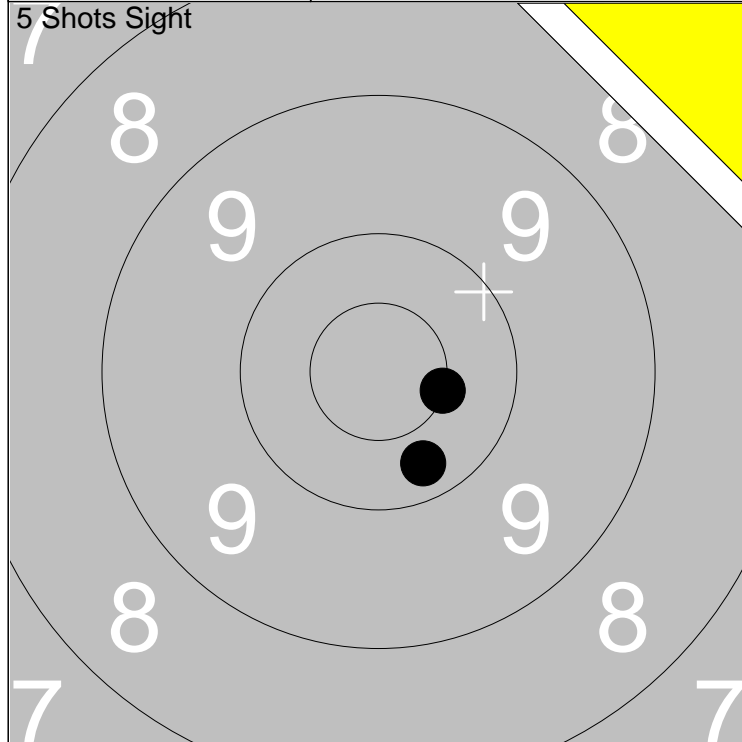

1: *10.5 →	Series	28.0
2: 10.3 ↓		
3: 8.1 ↗		
Total		139.0

1: 10.4 ←	Series	46.0
2: 10.0 ↓		
3: 10.1 ↙		
Total		185.0

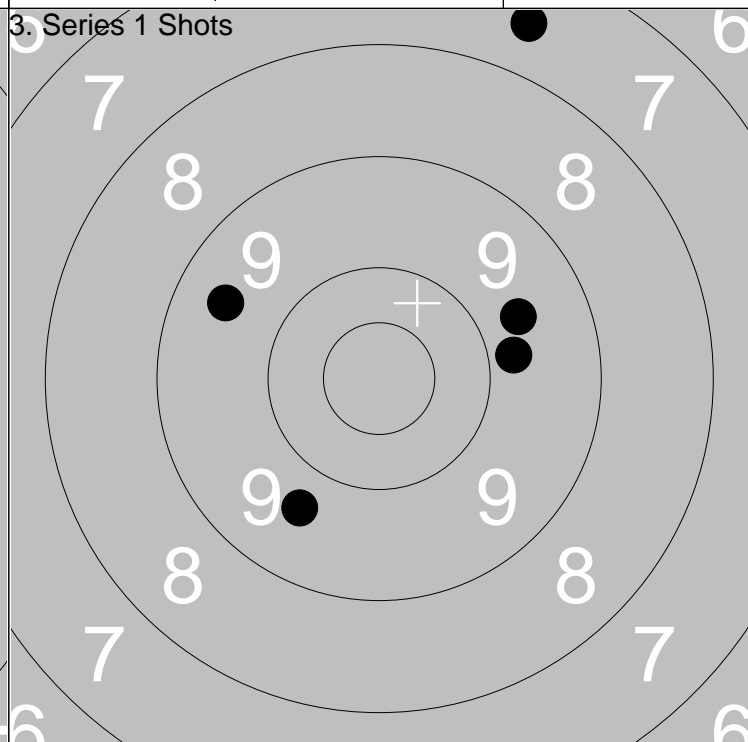
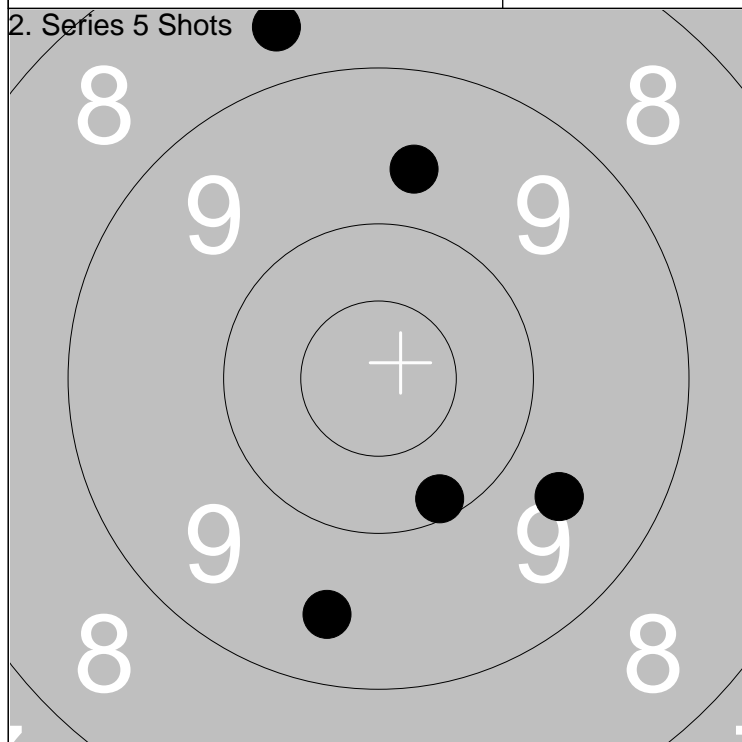

1: 10.1 ↓	Series	45.0
2: 8.7 ↗		
3: 9.5 ↓		
Total		230.0

1: 9.7 ↙	Series	43.0
2: 9.5 ←		
3: 9.8 →		
Total		273.0

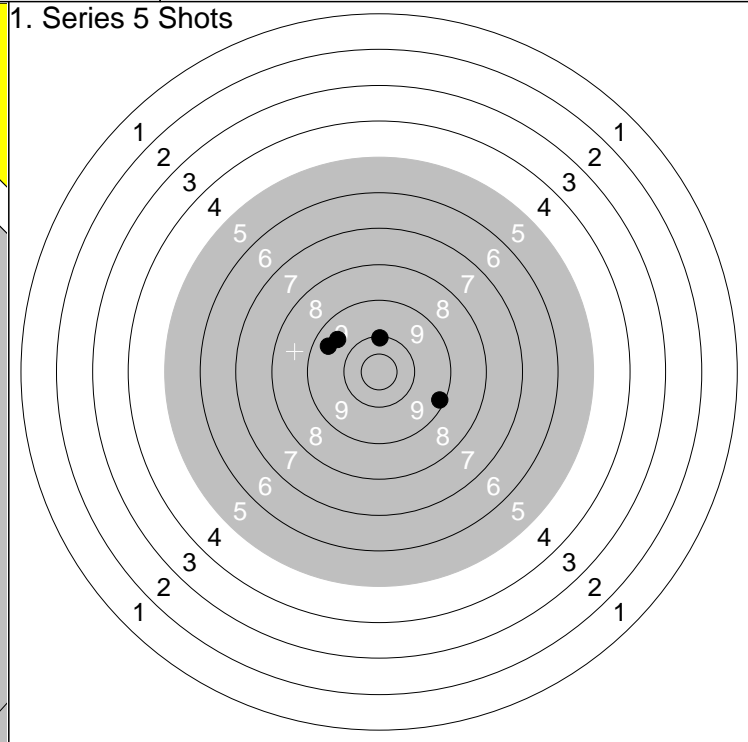
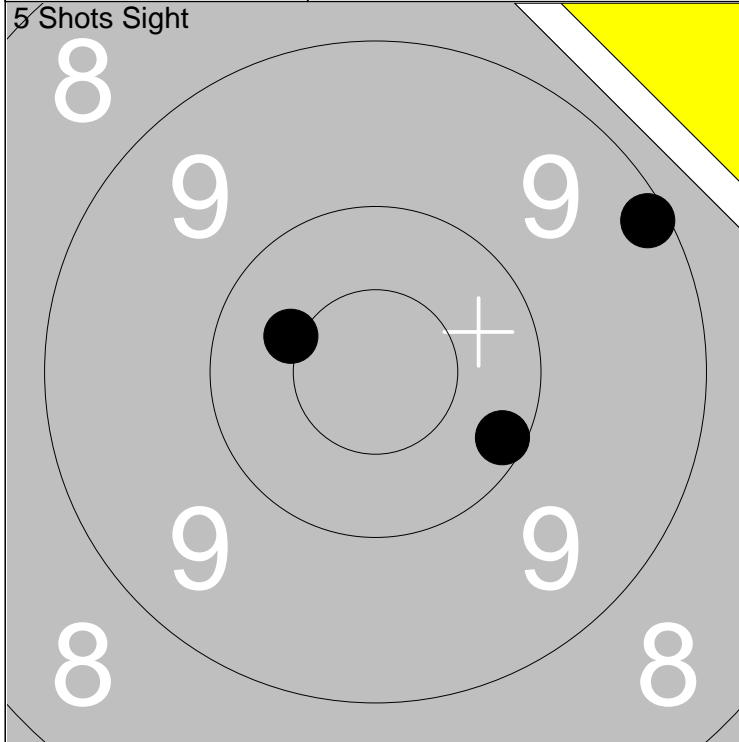

1: 9.1 ↗	Series	29.0
2: 10.1 ➤		
3: *10.4 ↖		
Total		139.0

1: 9.2 ➤	Series	37.0
2: 9.6 ↖		
3: 9.4 ↖		
4: 0.0 ←		
5: 10.1 ↑		
Total		176.0

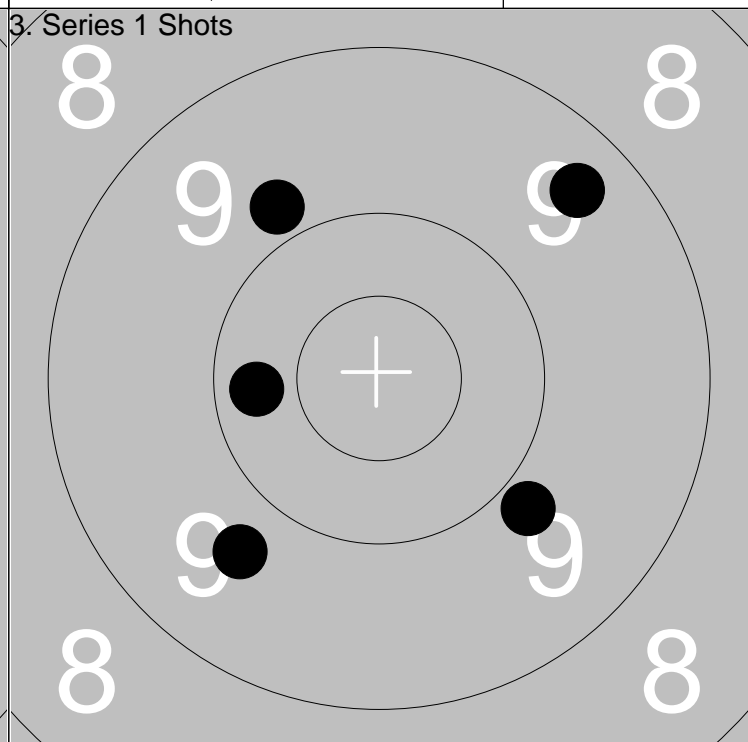
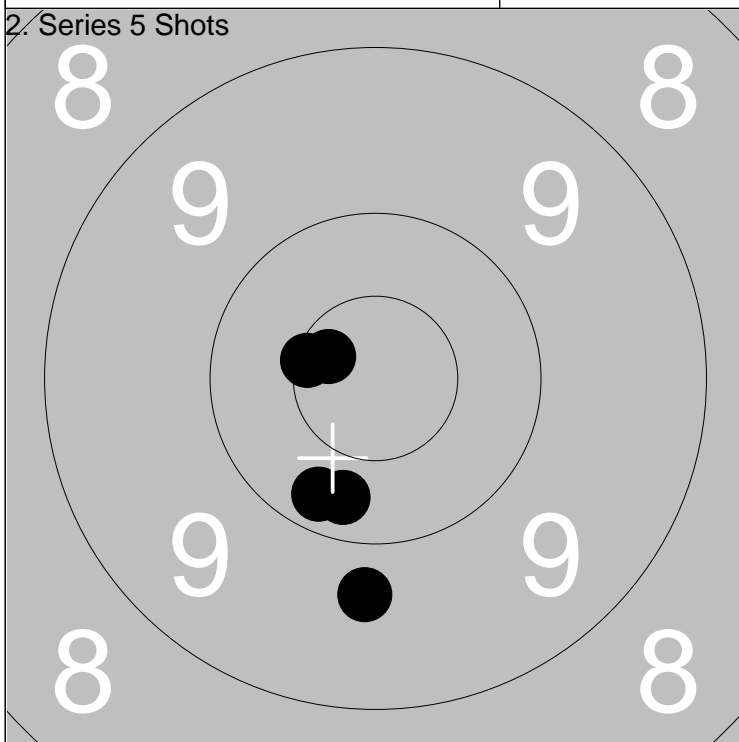

1: 9.7 ↓	Series	49.0
2: *10.6 ↖		
3: 10.2 ↓		
4: 10.3 ↓		
5: *10.7 ↖		
Total		225.0

1: 9.4 ↗	Series	46.0
2: 9.8 ↖		
3: 9.7 ↓		
4: 9.8 ➤		
5: 10.3 ←		
Total		271.0

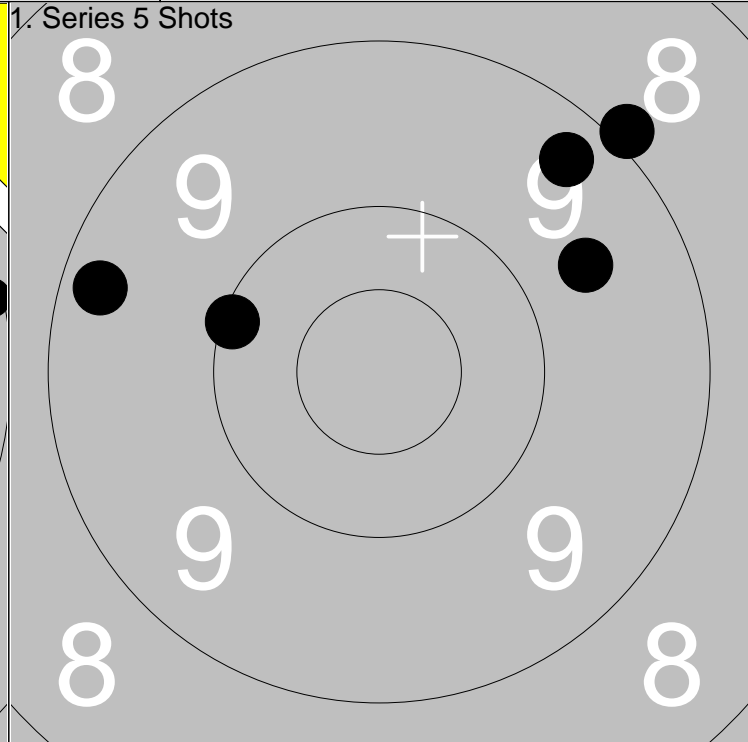
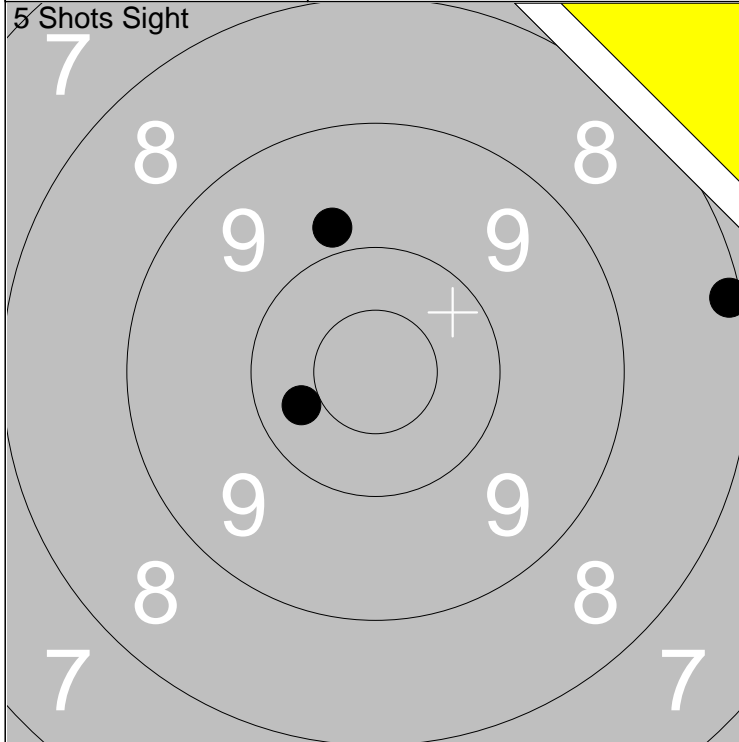

1: 10.3 ←	Series 27.0
2: 9.8 ↑	
3: 8.1 →	
Total 139.0	

1: 9.3 ↗	Series 45.0
2: 9.6 →	
3: 8.9 ↗	
4: 9.3 ←	
5: 10.1 ←	
Total 184.0	

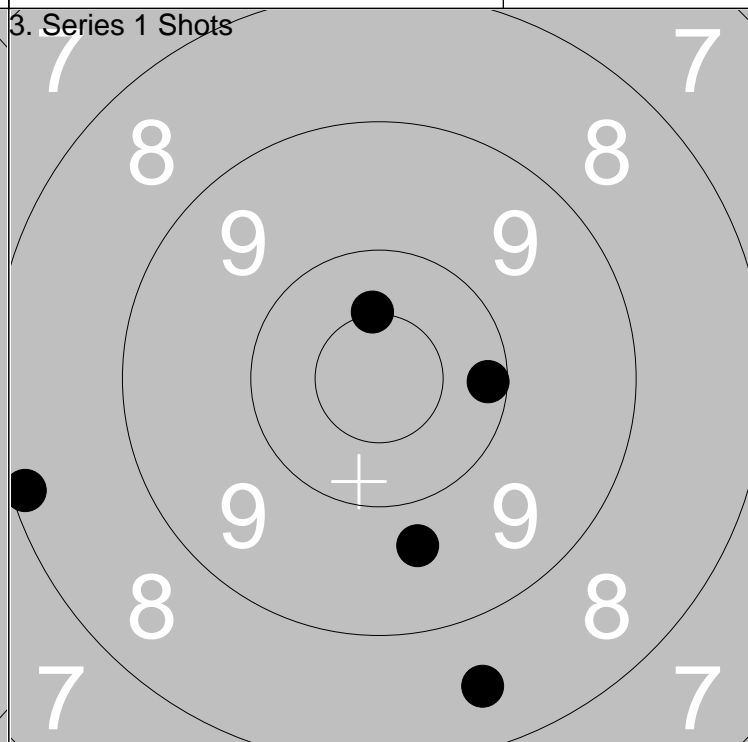
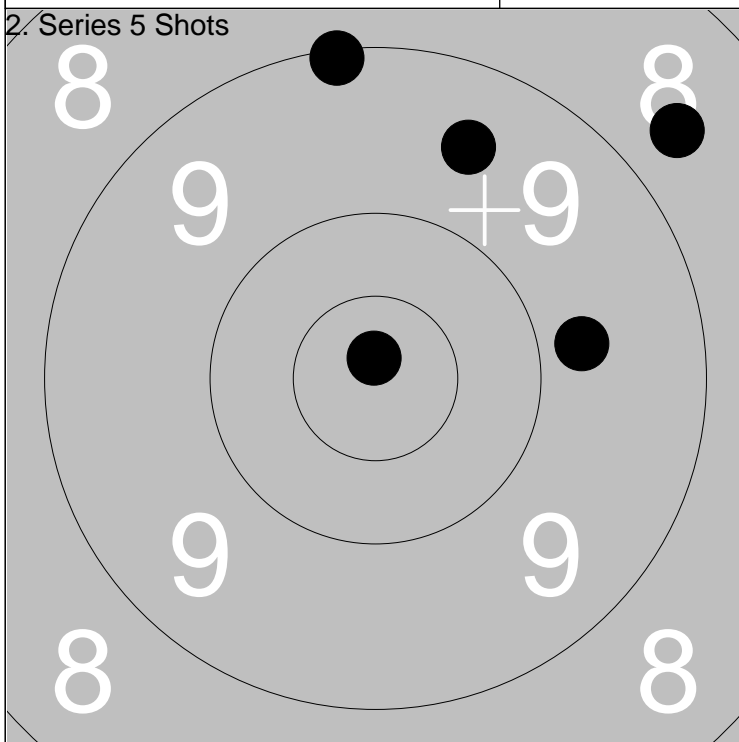

1: 9.8 →	Series 45.0
2: 8.7 ↗	
3: 9.1 ↑	
4: *10.8 ↑	
5: 9.5 ↑	
Total 229.0	

1: 8.5 ↓	Series 45.0
2: *10.5 ↑	
3: 10.2 →	
4: 9.7 ↓	
5: 8.1 ←	
Total 274.0	

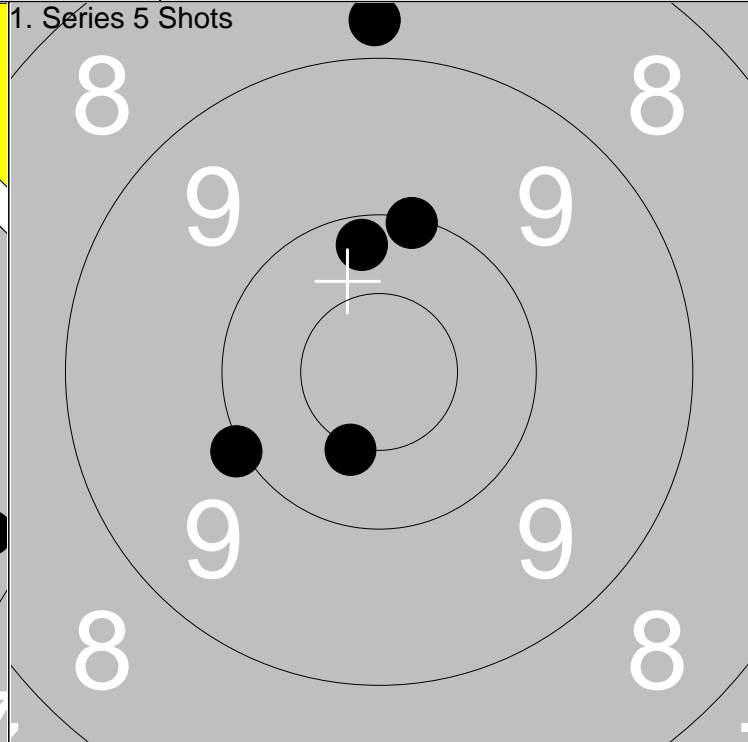
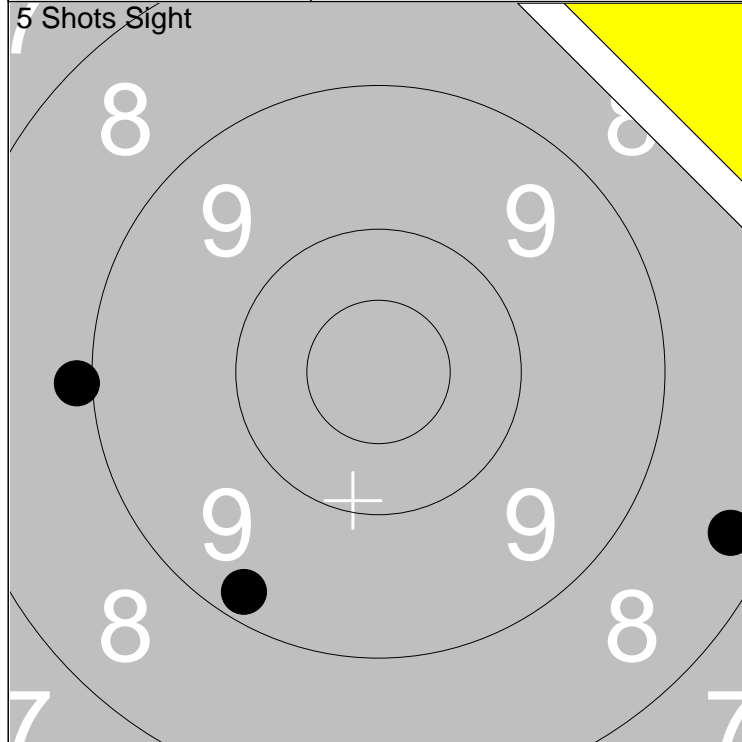

1: 8.3 →
2: 8.9 ←
3: 9.2 ↓

Series	25.0
Total	134.0

1: *10.5 ↓
2: 10.2 ↑
3: 8.8 ↑
4: 10.0 ↙
5: 10.1 ↑

Series	48.0
Total	182.0

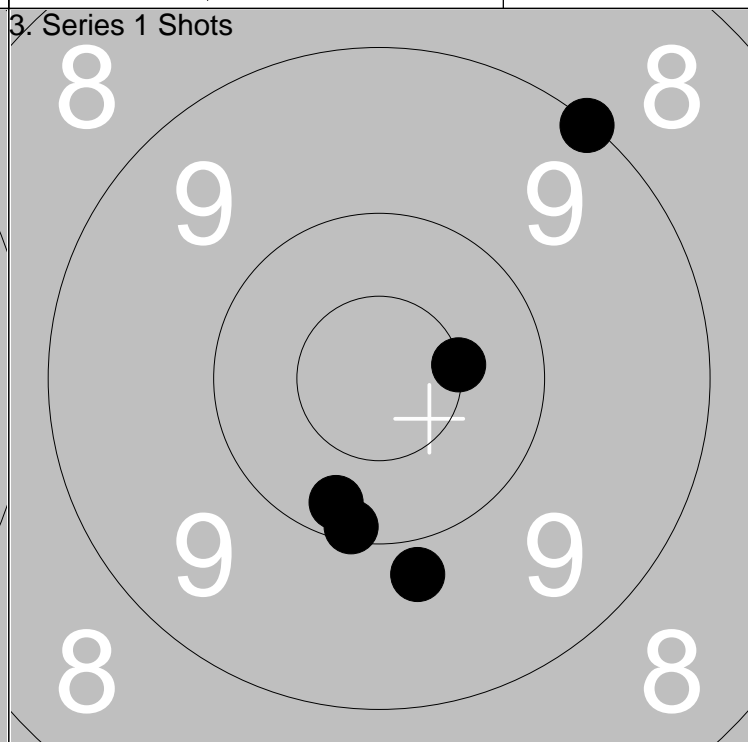
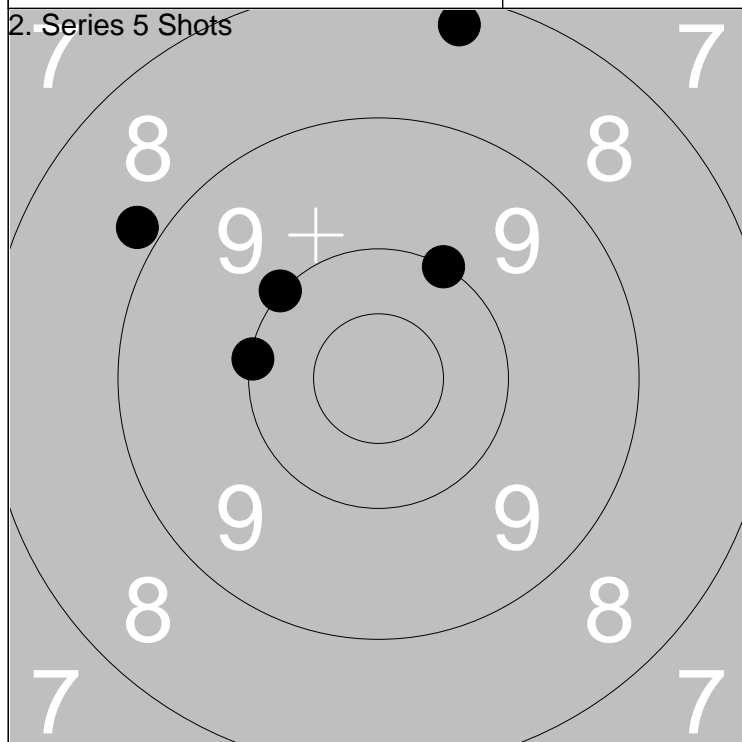

1: 10.0 ↙
2: 10.0 ↖
3: 8.2 ↑
4: 8.8 ↖
5: 10.0 ↗

Series	46.0
Total	228.0

1: 9.8 ↓
2: 10.1 ↓
3: 9.1 ↗
4: *10.5 →
5: 10.2 ↓

Series	48.0
Total	276.0

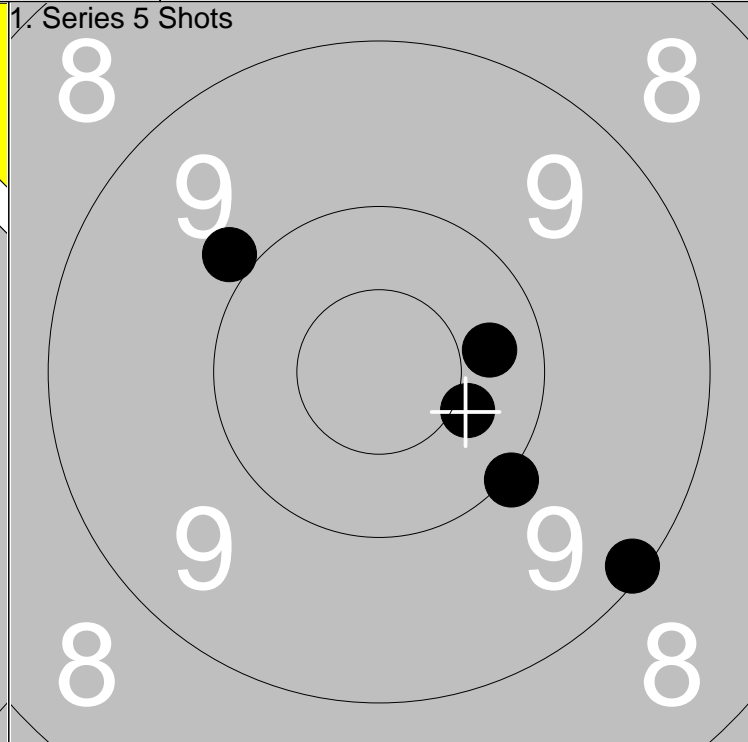
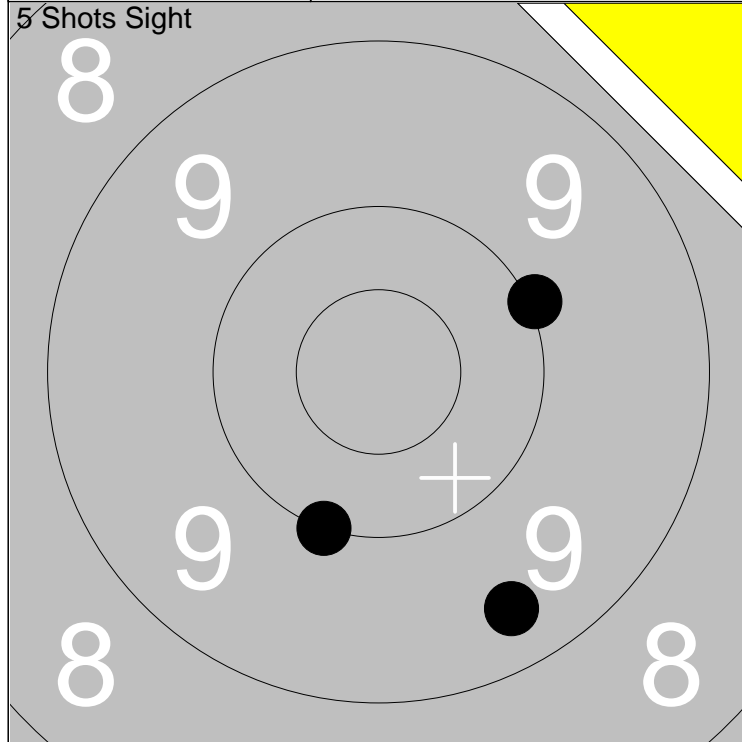

1: 9.4 ↓	Series	29.0
2: 10.0 →		
3: 10.0 ↓		
Total		149.0

1: 9.1 ↓	Series	48.0
2: 10.0 ↓		
3: 10.4 →		
4: 9.9 ↖		
5: 10.3 →		
Total		197.0

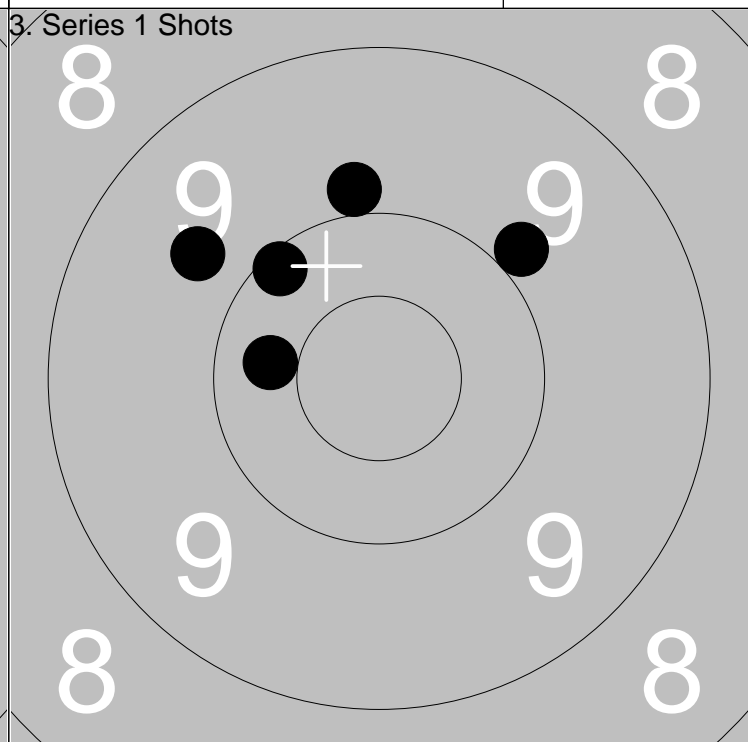
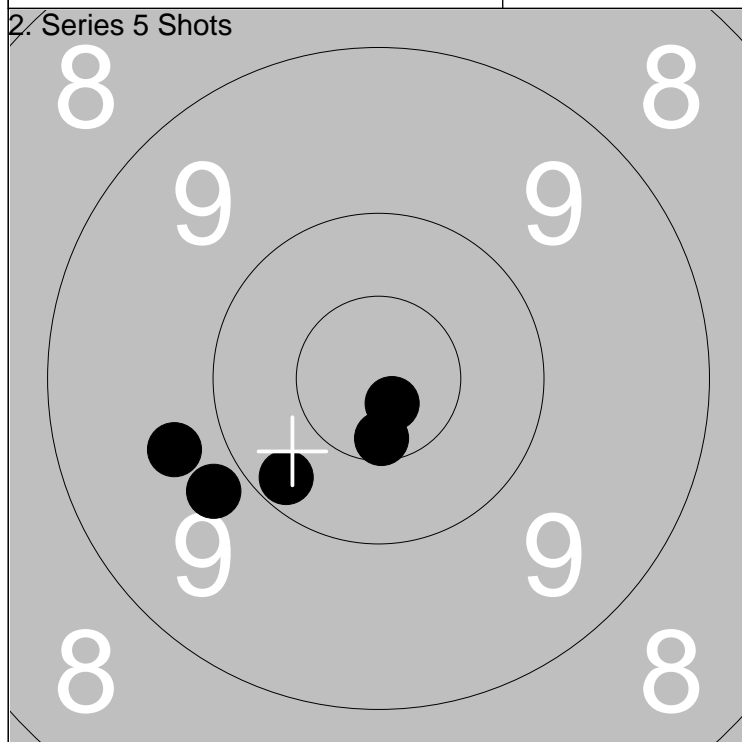

1: *10.8 ↓	Series	48.0
2: 9.8 ↙		
3: *10.6 ↓		
4: 10.2 ↓		
5: 9.7 ←		
Total		245.0

1: 9.9 ↑	Series	47.0
2: 9.9 ↗		
3: 10.1 ↖		
4: 9.7 ↖		
5: 10.3 ←		
Total		292.0

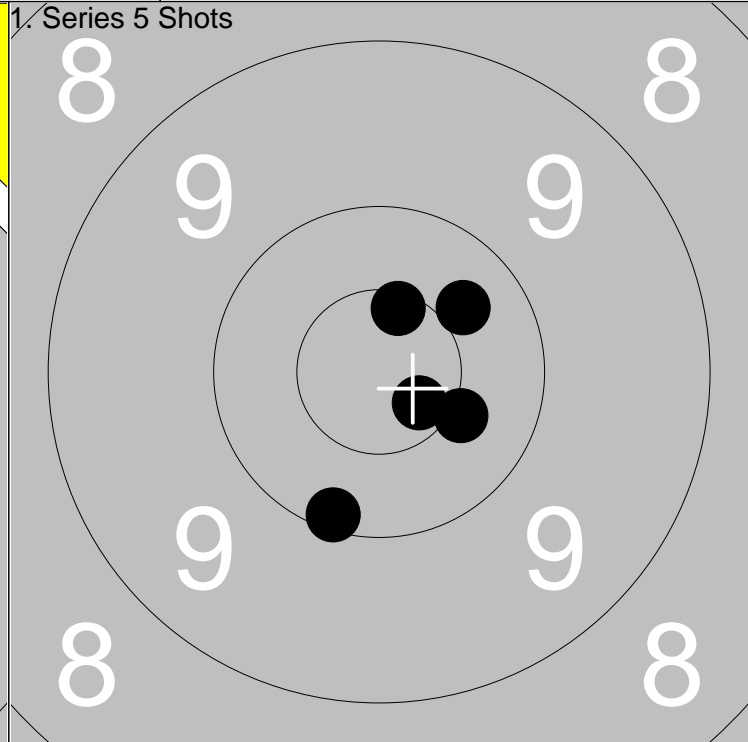
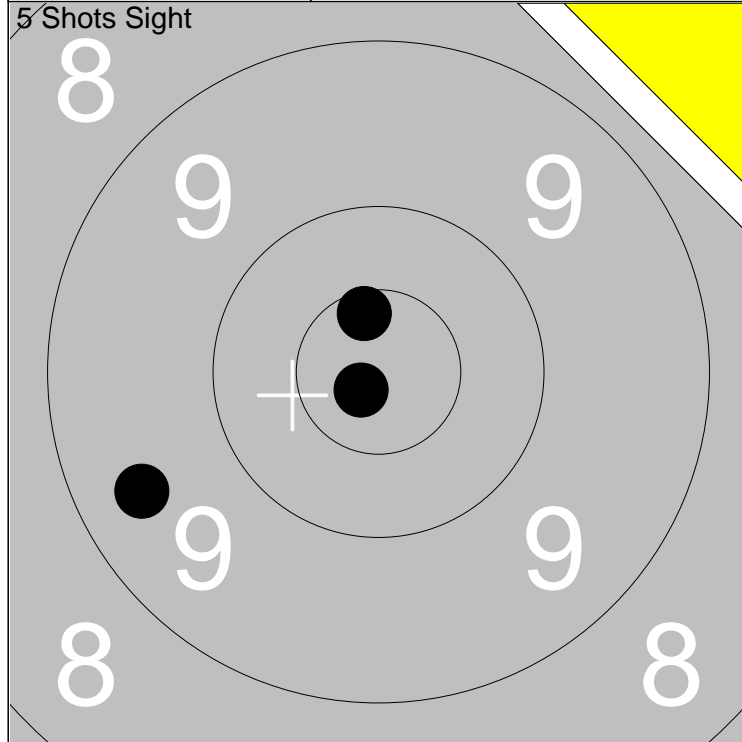

1: *10.6↑	Series 29.0
2: *10.8↙	
3: 9.4 ↙	
Total 148.0	

1: 10.1 ↓	Series 50.0
2: *10.6↑	
3: *10.7↘	
Total 198.0	

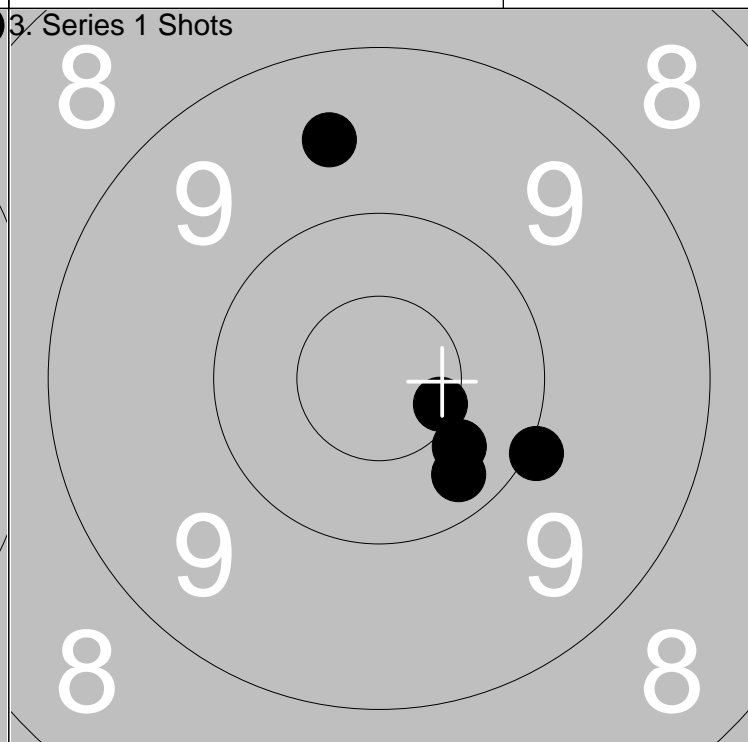
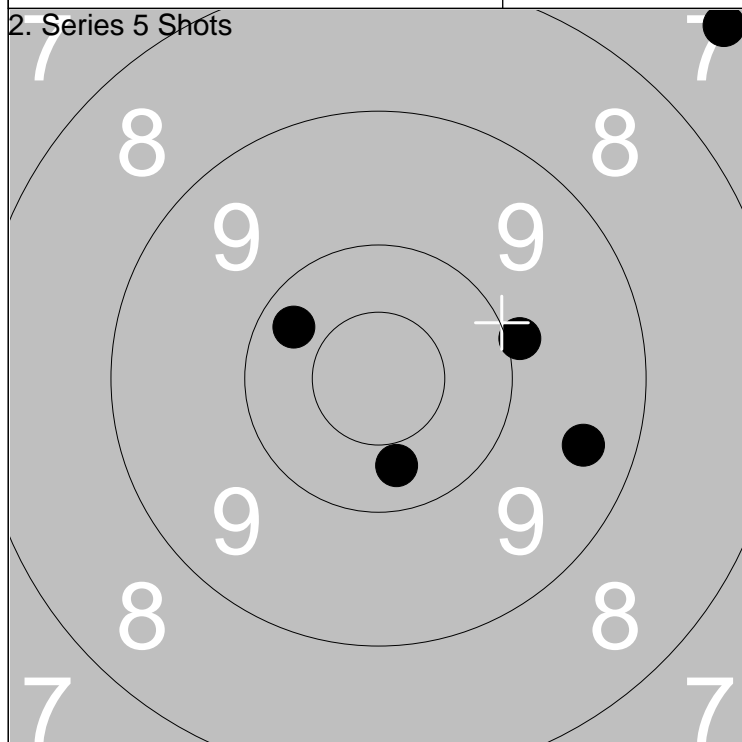

1: 10.3 ↙	Series 45.0
2: 7.3 ↗	
3: 10.3 ↓	
Total 243.0	

1: *10.6↘	Series 49.0
2: 9.6 ↑	
3: 10.3 ↓	
Total 292.0	

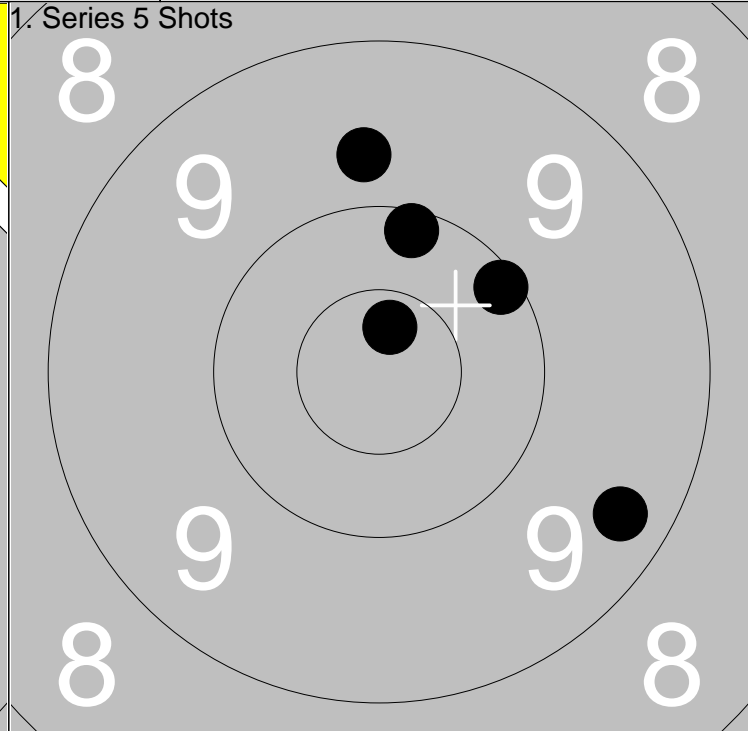
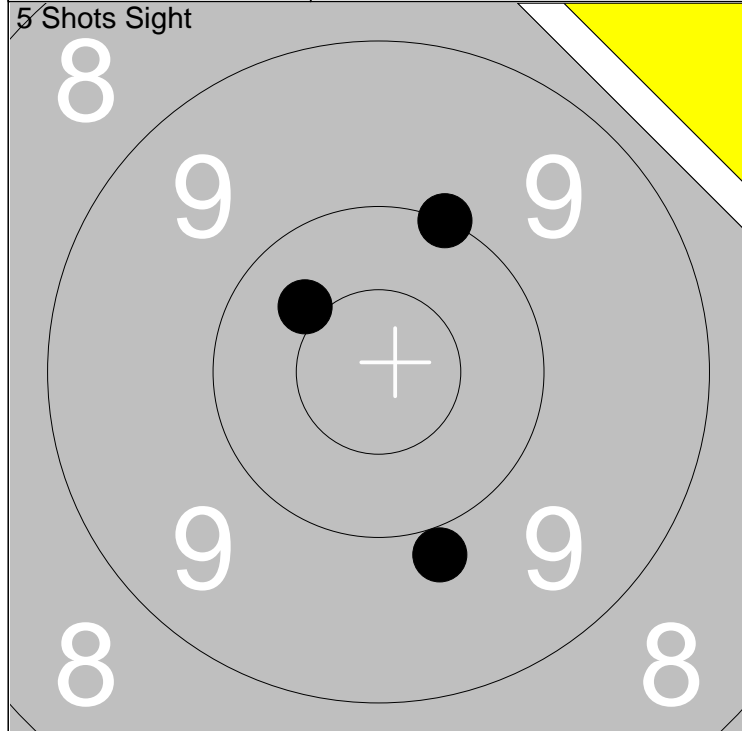

1: 9.9 ↓	Series	29.0
2: 10.4 ↖		
3: 10.0 ↗		
Total		147.0

1: 10.1 ↑	Series	48.0
2: 9.7 ↑		
3: 10.1 ↗		
Total		195.0

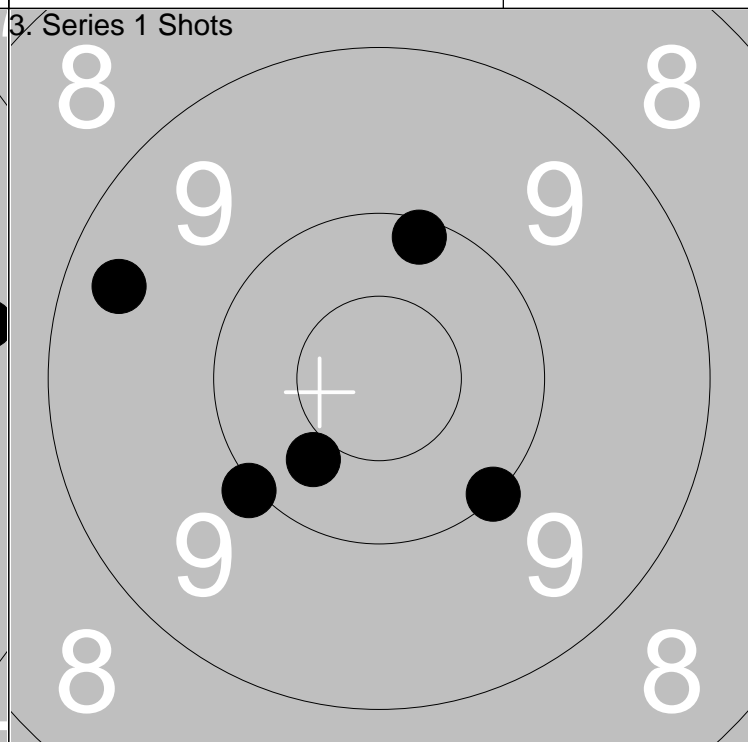
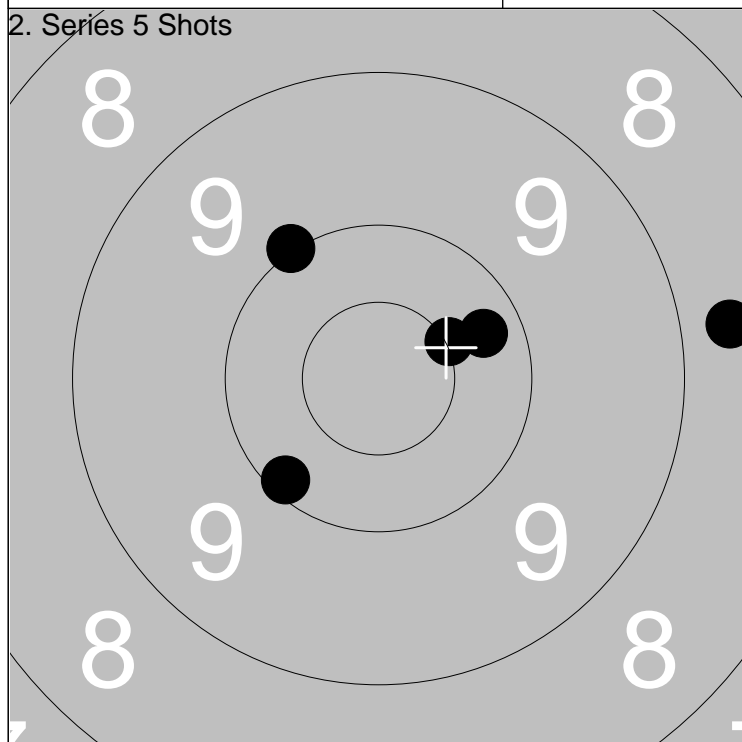

1: 10.0 ↖	Series	48.0
2: 10.3 ↗		
3: *10.5 ↗		
Total		243.0

1: 10.0 ↙	Series	49.0
2: 9.4 ↖		
3: 10.0 ↘		
Total		292.0

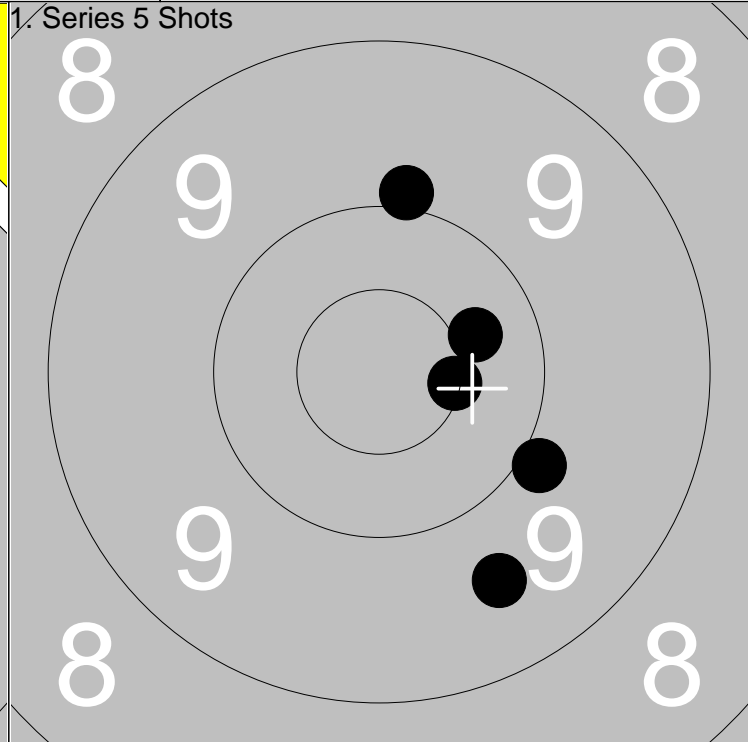
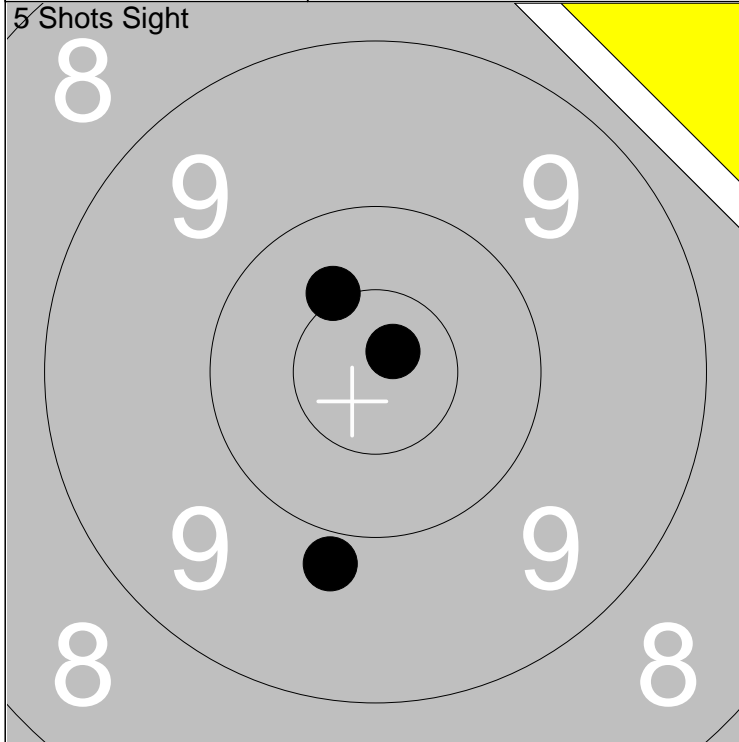

1: 9.8 ↓	Series	29.0
2: *10.4 ↖		
3: *10.8 ↗		
Total		147.0

1: *10.5 →	Series	47.0
2: 9.9 ↑		
3: 10.4 →		
Total		194.0

4: 9.6 ↓	Series	48.0
5: 9.9 →		
Total		

1: 10.2 ↖	Series	48.0
2: 9.3 ↓		
3: 9.6 ↓		
Total		290.0

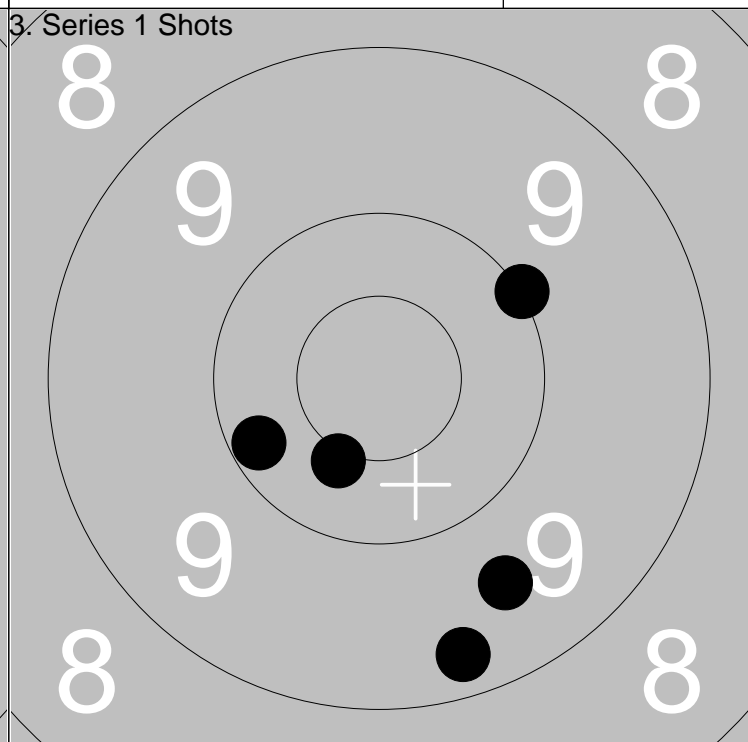
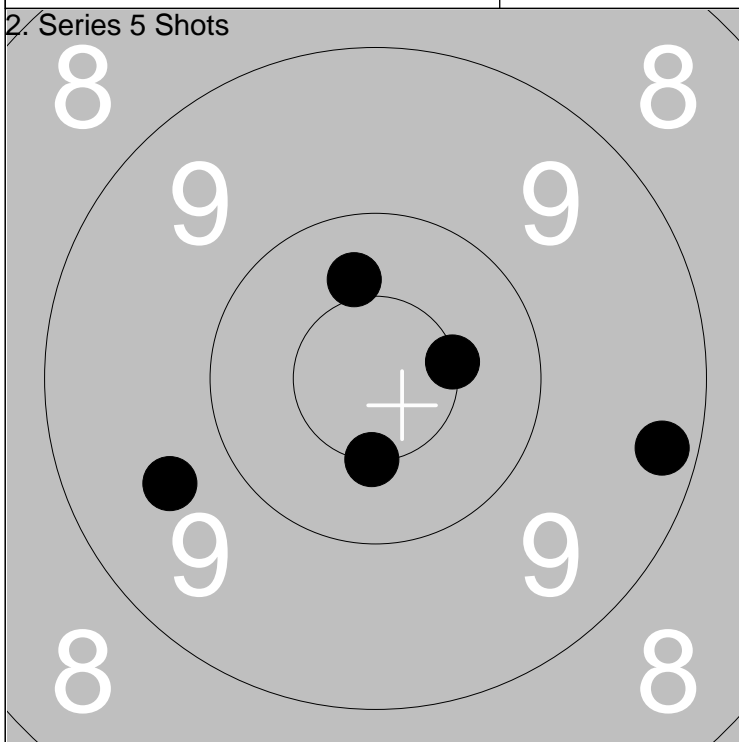

1: 9.6 ↖	Series	48.0
2: *10.5 ↓		
3: *10.5 →		
Total		242.0

4: 10.4 ↑	Series	48.0
5: 9.2 →		
Total		

1: 10.2 ↖	Series	48.0
2: 9.3 ↓		
3: 9.6 ↓		
Total		290.0

4: 10.0 ↗	Series	48.0
5: *10.4 ↓		
Total		

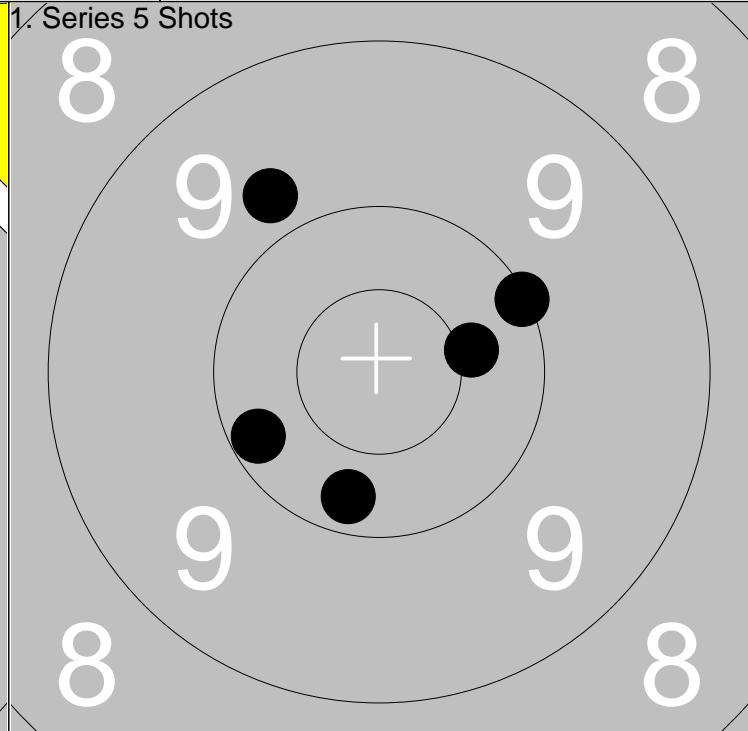
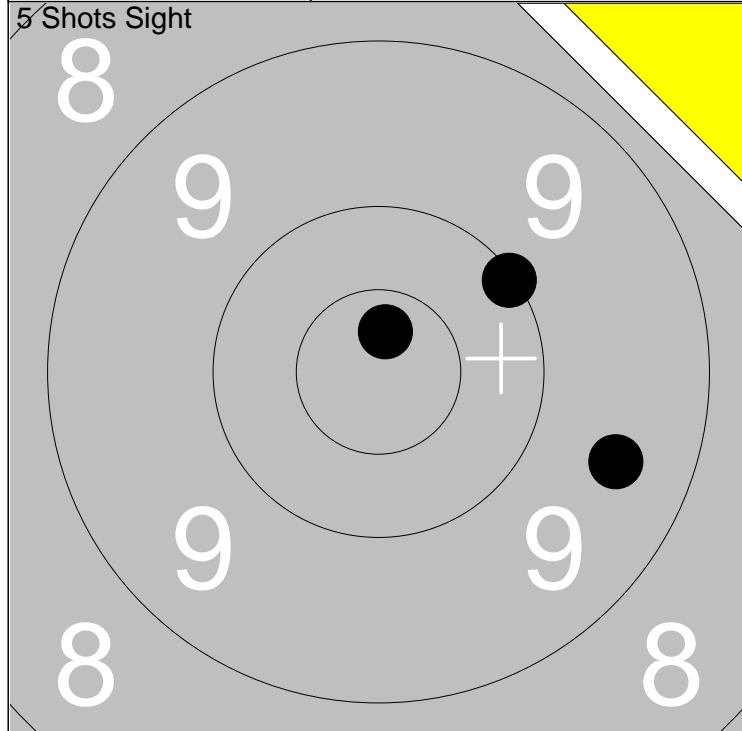

1: *10.7↑	Series	29.0
2: 10.1 ↗		
3: 9.5 ➔		
Total		146.0

1: 10.2 ↙	Series	49.0
2: 9.8 ↖		
3: 10.1 ↗		
Total		195.0

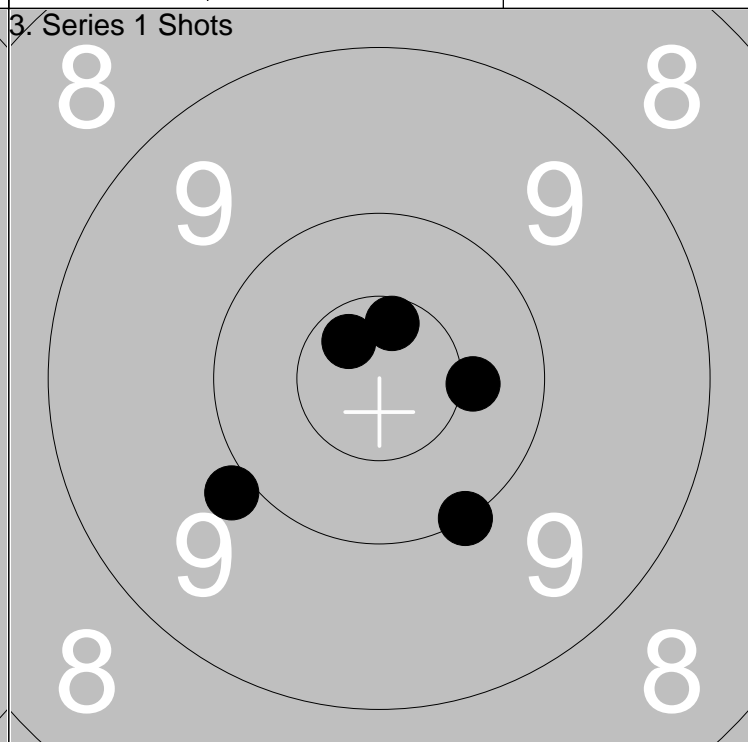
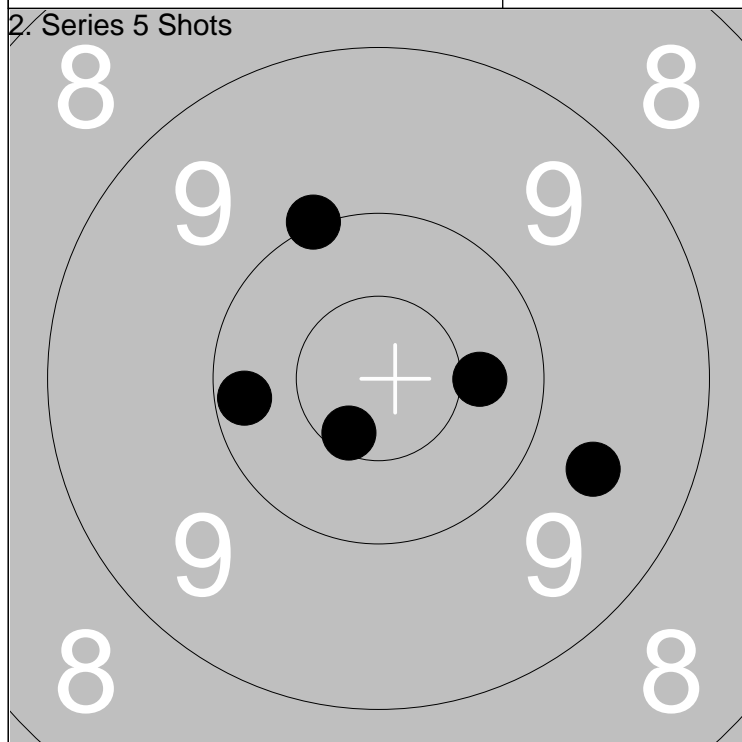

1: *10.6↘	Series	49.0
2: 10.4 ➔		
3: 10.2 ↙		
Total		244.0

1: 9.9 ↙	Series	49.0
2: *10.6↑		
3: *10.4➔		
Total		293.0

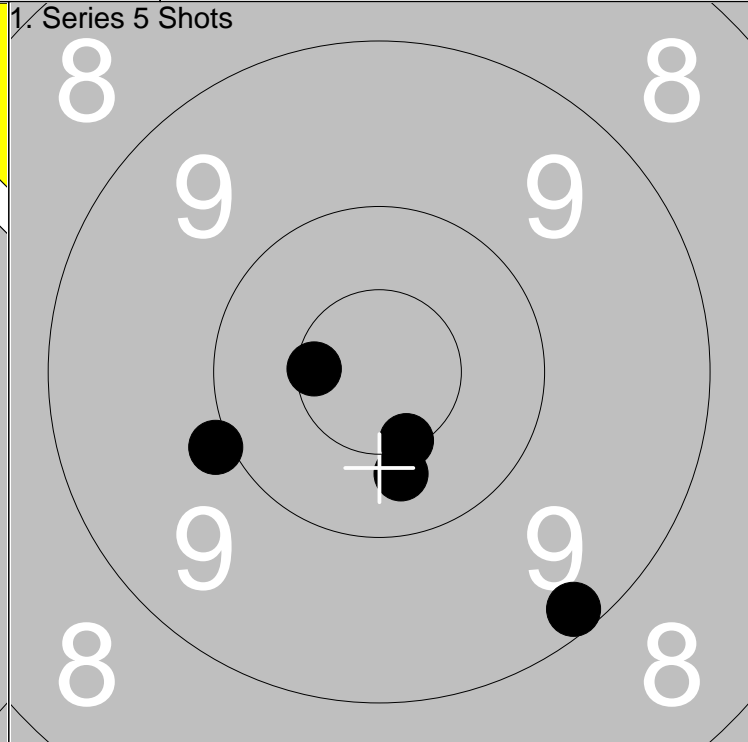
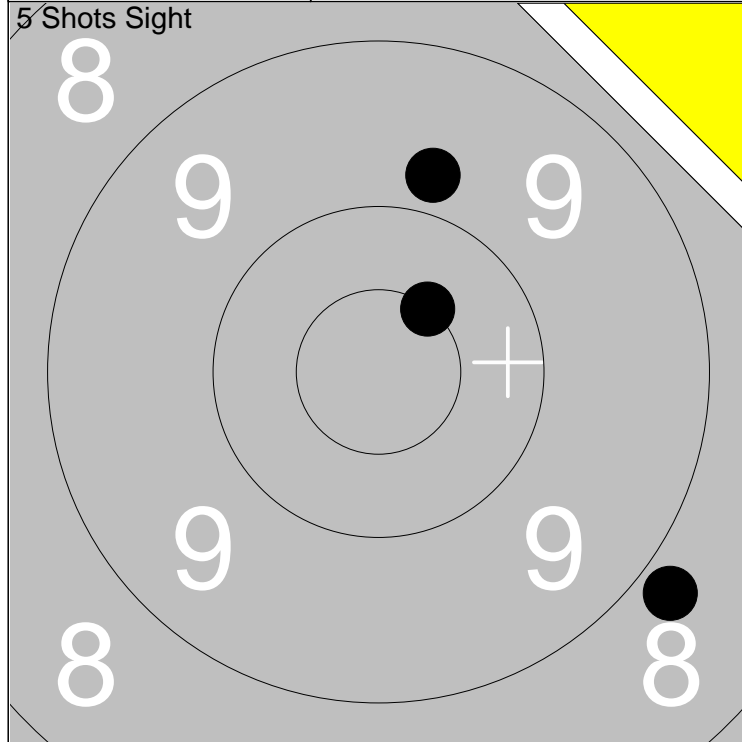

1: *10.5 ↗	Series 27.0
2: 9.8 ↑	
3: 8.8 ↘	
Total 146.0	

1: 9.2 ↘	Series 48.0
2: *10.5 ↘	
3: 10.4 ↘	
4: 9.9 ↙	
5: *10.6 ↙	
Total 194.0	

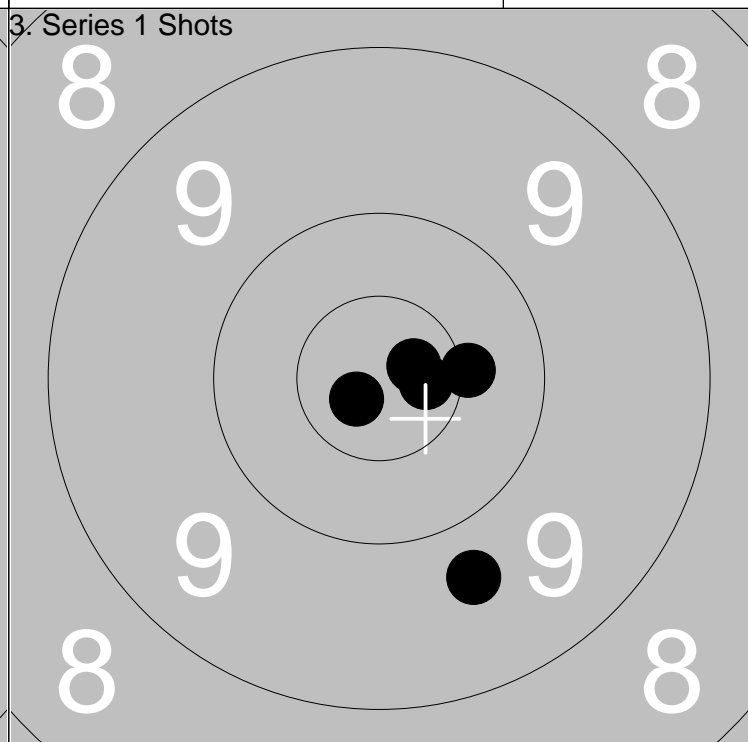
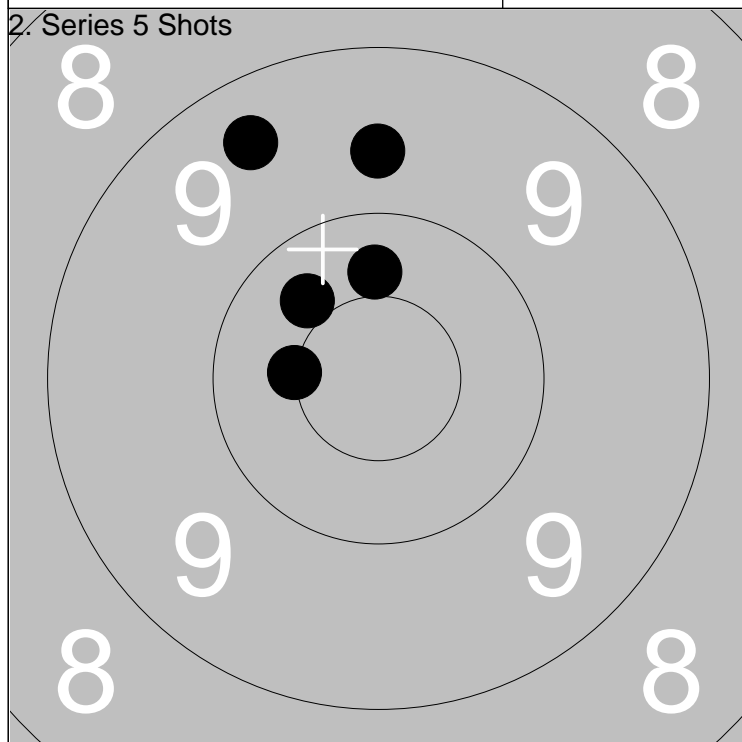

1: *10.5 ↙	Series 48.0
2: 10.4 ↖	
3: 10.4 ↑	
4: 9.4 ↖	
5: 9.7 ↑	
Total 242.0	

1: 9.7 ↘	Series 49.0
2: *10.8 ↙	
3: *10.4 →	
4: *10.7 →	
5: *10.7 →	
Total 291.0	

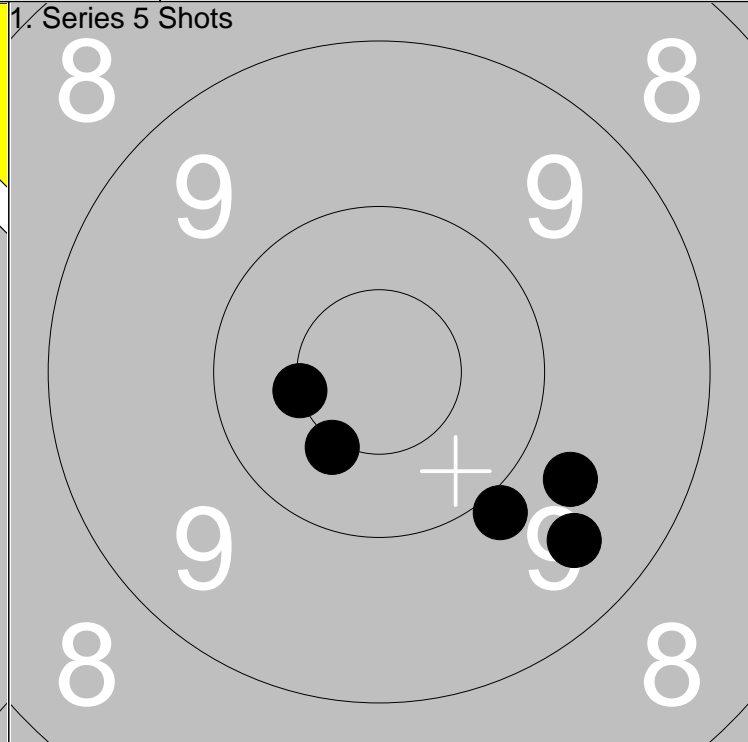
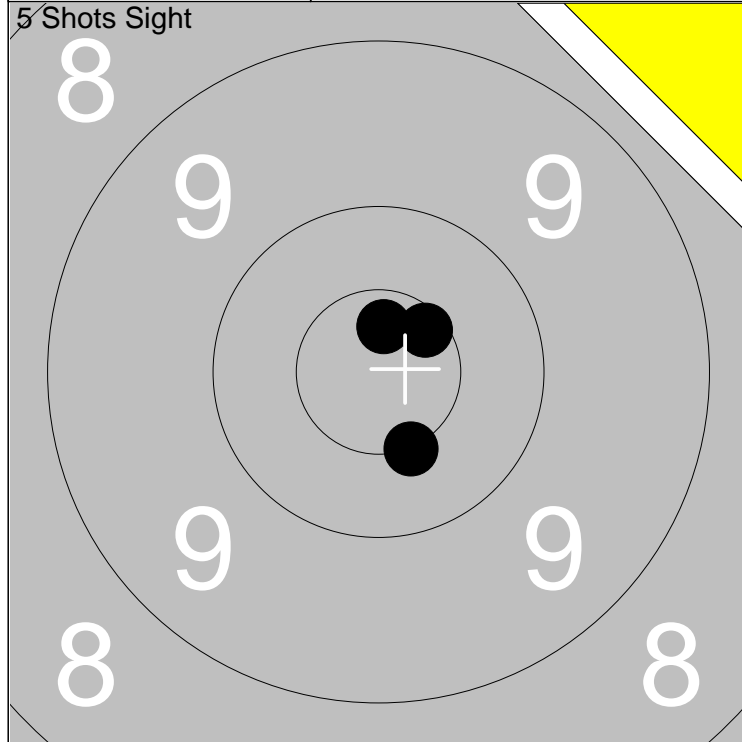

1: *10.6 ↗	Series	30.0
2: *10.7 ↑		
3: *10.5 ↘		
Total		145.0

1: *10.5 ↘	Series	47.0
2: 9.5 ↘		
3: 9.9 ↘		
4: 9.7 ↘		
5: *10.5 ↙		
Total		192.0

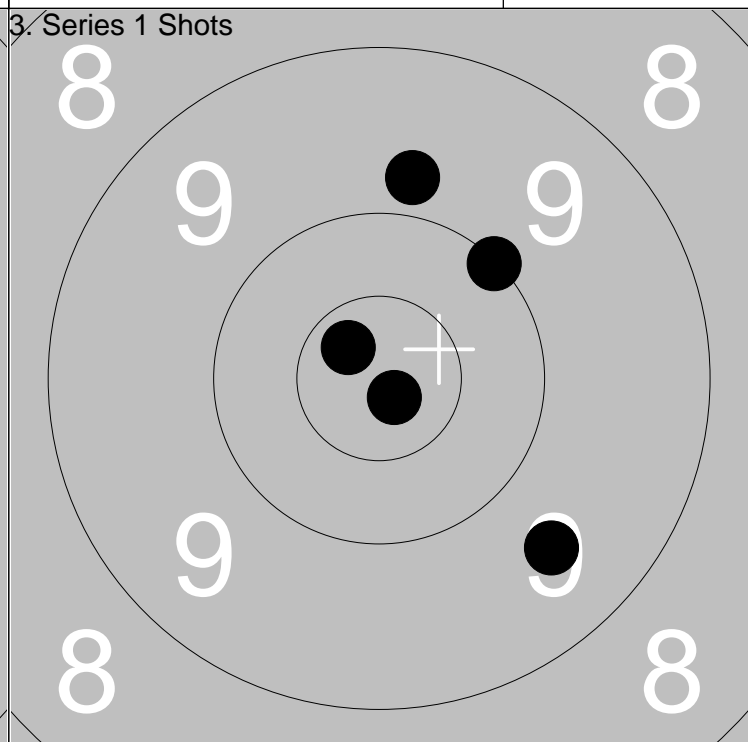
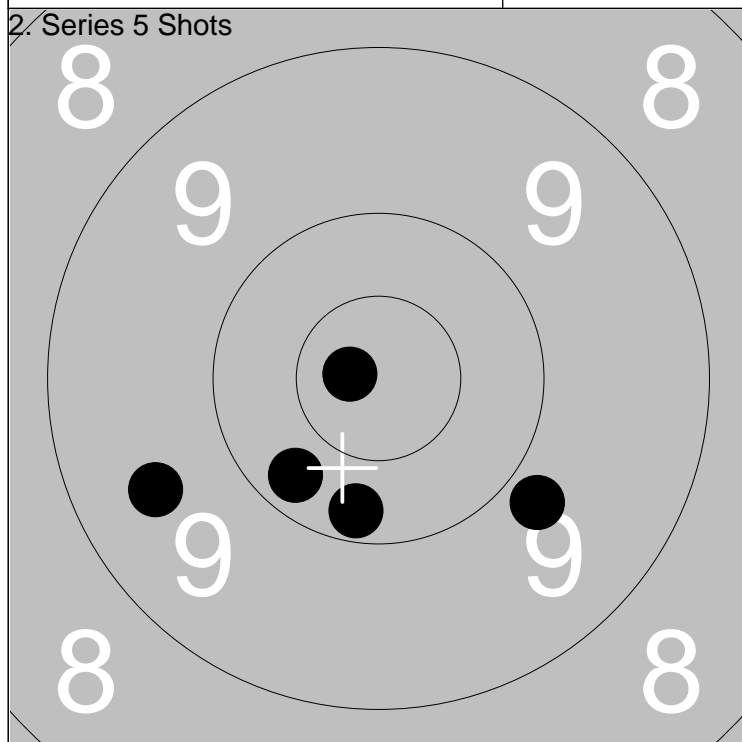

1: *10.8 ↙	Series	48.0
2: 9.5 ↙		
3: 10.2 ↘		
4: 10.2 ↘		
5: 9.8 ↘		
Total		240.0

1: *10.8 ↘	Series	48.0
2: 9.8 ↑		
3: 10.0 ↗		
4: 9.6 ↘		
5: *10.7 ↙		
Total		288.0

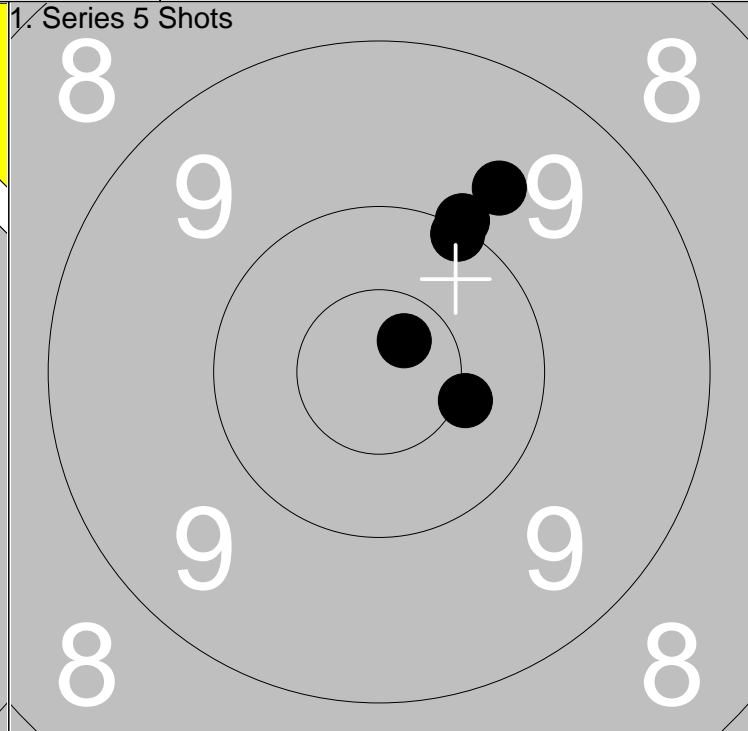
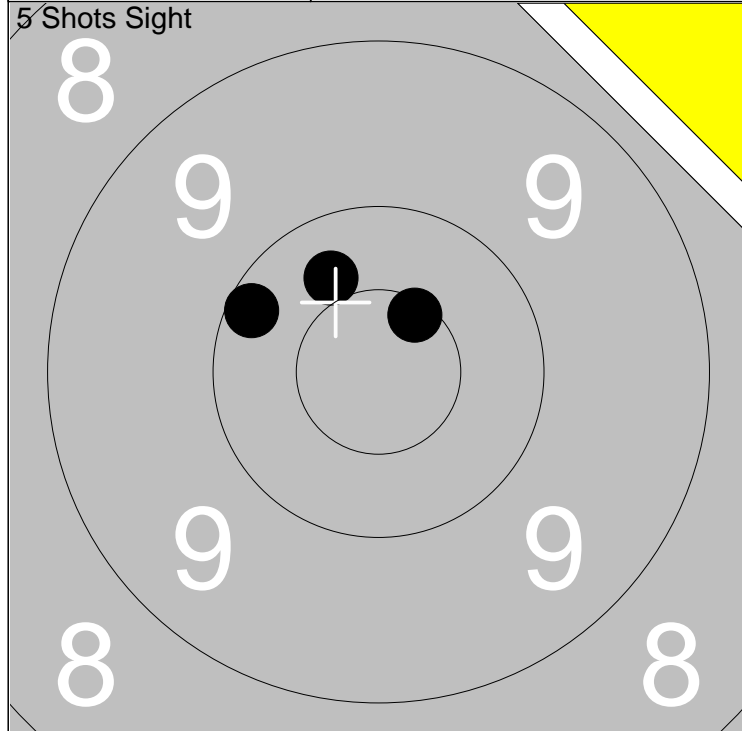

1: 10.4 ↖	Series	30.0
2: 10.2 ↙		
3: *10.6 ↗		
Total		144.0

1: 10.1 ↗	Series	49.0
2: 9.7 ↗		
3: *10.7 ↗		
4: *10.4 →		
5: 10.0 ↗		
Total		193.0

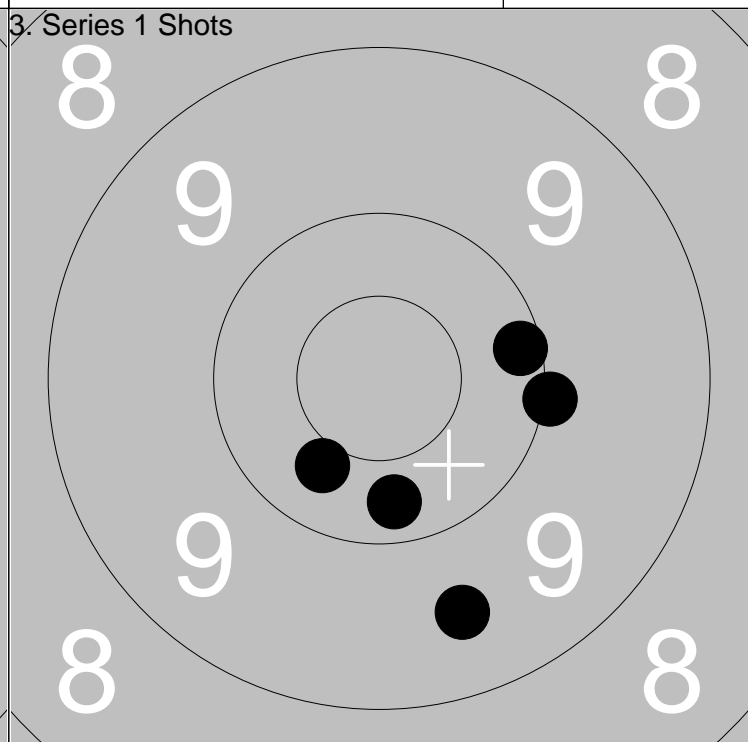
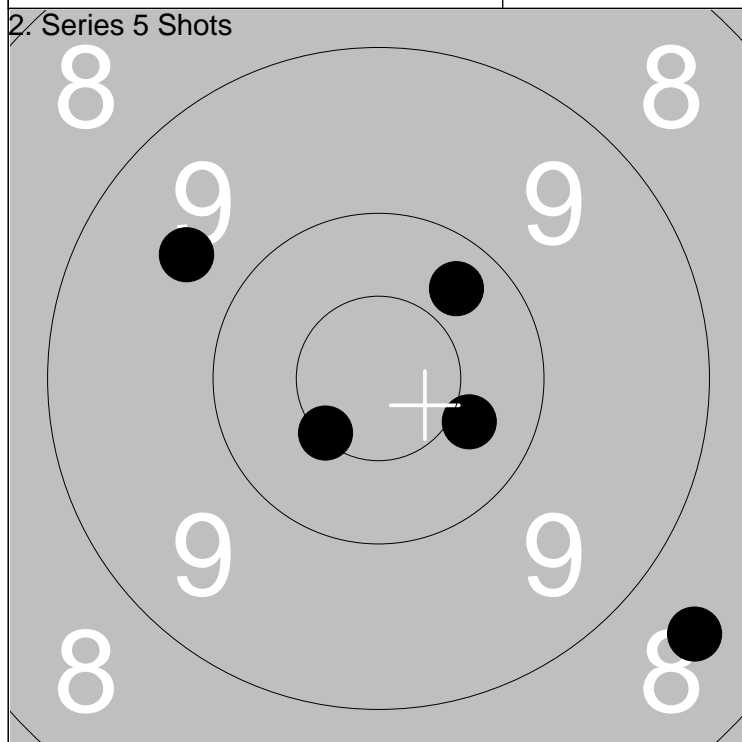

1: 9.6 ↙	Series	47.0
2: 10.3 ↗		
3: 10.4 →		
4: *10.5 ↙		
5: 8.6 ↘		
Total		240.0

1: 10.1 →	Series	49.0
2: 10.4 ↙		
3: 9.5 ↓		
4: 10.0 →		
5: 10.3 ↓		
Total		289.0

Relay 6	Lane 9	Elin Åhlin	
-------------------	------------------	-------------------	--

300m	Bälgviken	A	Sö
------	-----------	---	----

2013-07-07	Tavelträffen A 2013	Ramselefors SKF
------------	---------------------	-----------------

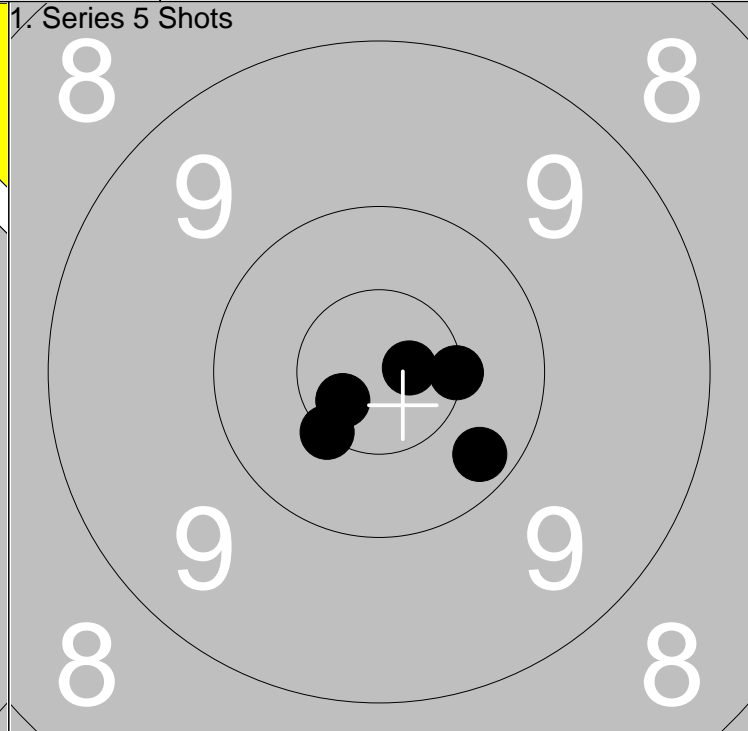
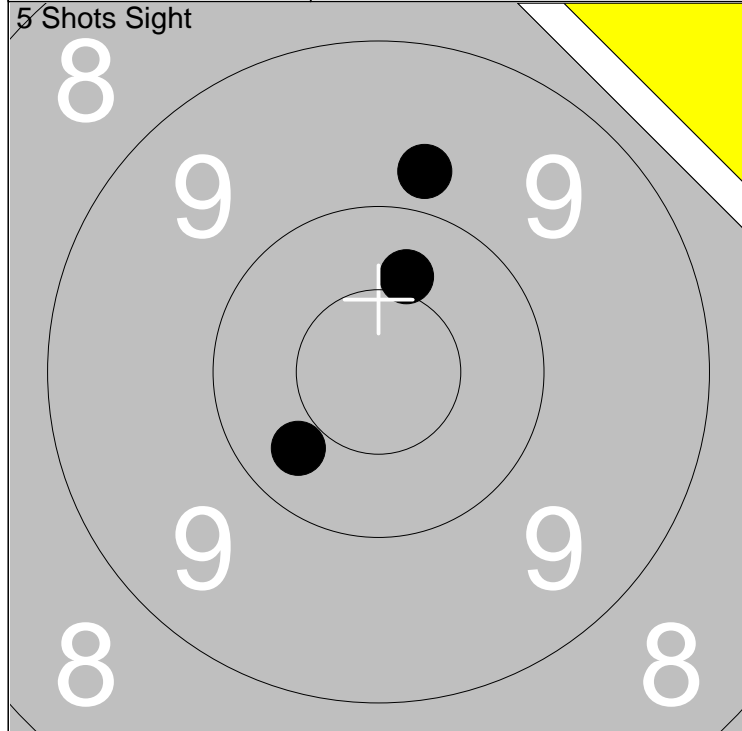

1: 9.8 ↑	Series	29.0
2: 10.4 ↑		
3: 10.3 ↙		
Total		144.0

1: 10.2 ↘	Series	50.0
2: *10.8 →		
3: *10.7 ↙		
4: *10.5 ↙		
5: *10.5 →		
Total		194.0

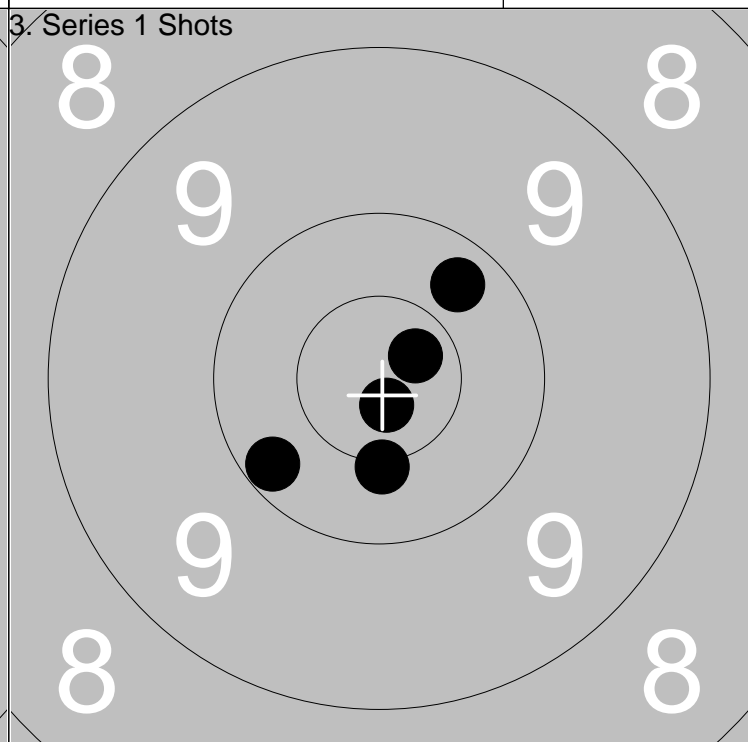
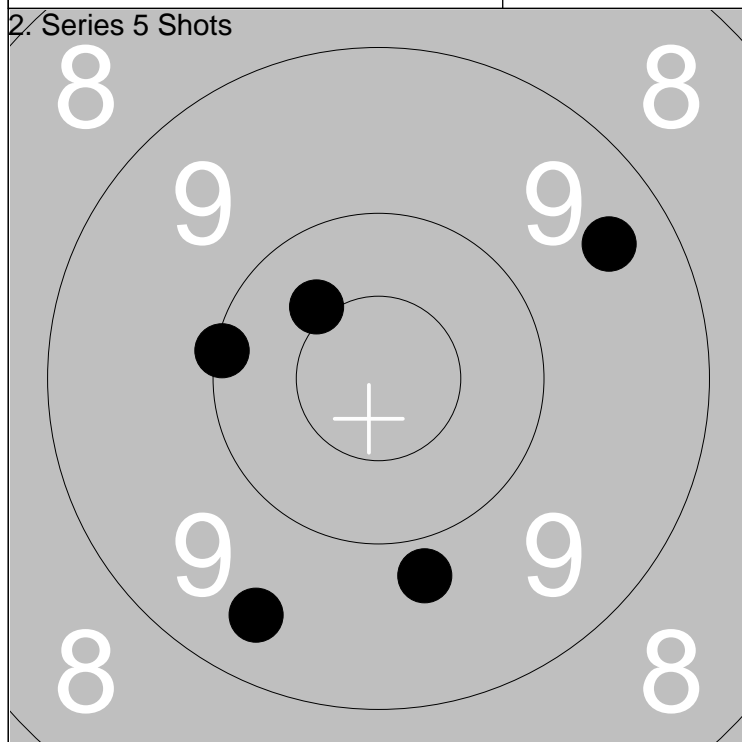

1: 10.1 ←	Series	47.0
2: *10.4 ↗		
3: 9.8 ↓		
4: 9.4 ↙		
5: 9.4 ↗		
Total		241.0

1: 10.3 ↗	Series	50.0
2: *10.8 ↓		
3: 10.2 ↙		
4: *10.7 ↗		
5: *10.5 ↓		
Total		291.0

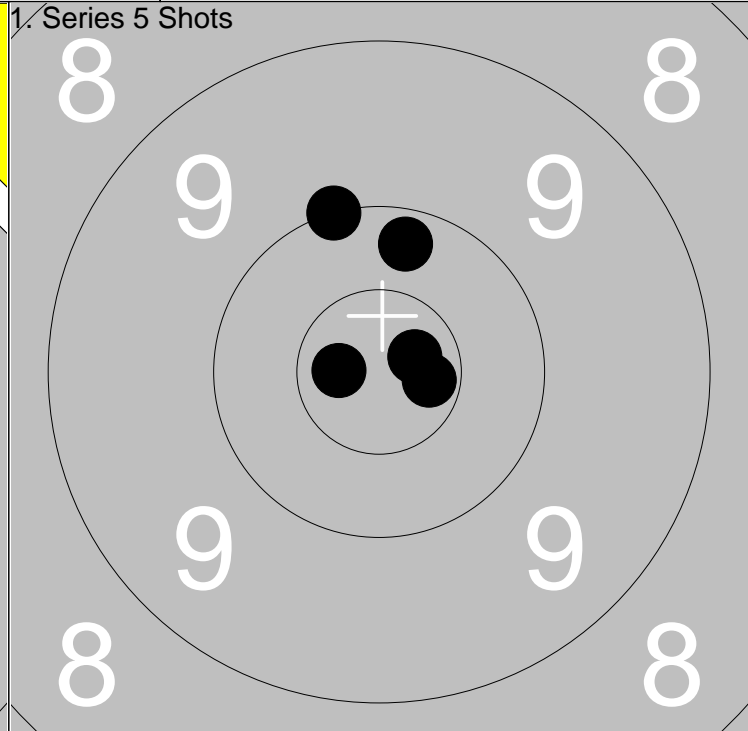
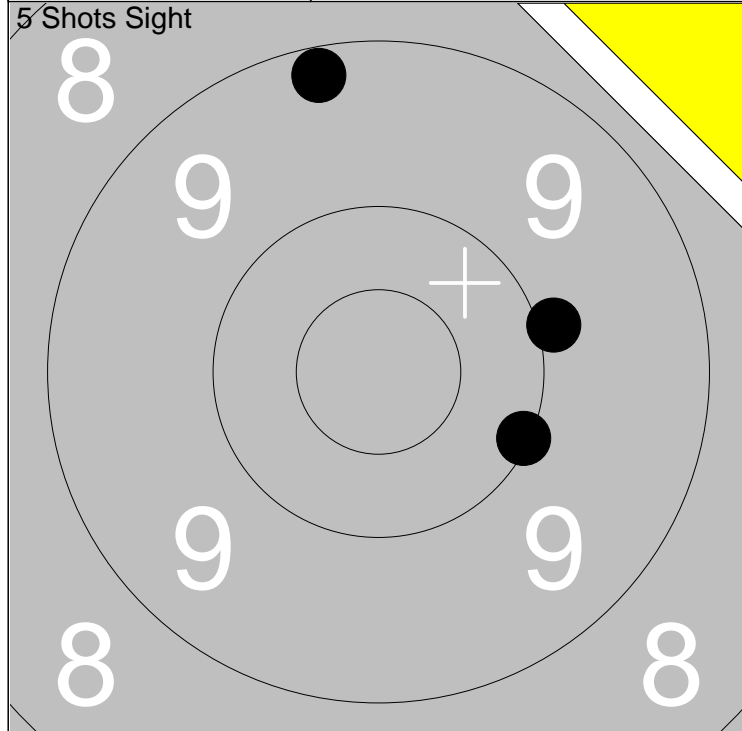

1: 10.1 ↘	Series	28.0
2: 9.2 ↑		
3: 9.9 →		
Total		144.0

1: *10.7 ←	Series	50.0
2: *10.7 →		
3: 10.2 ↑		
4: 10.0 ↑		
5: *10.7 →		
Total		194.0

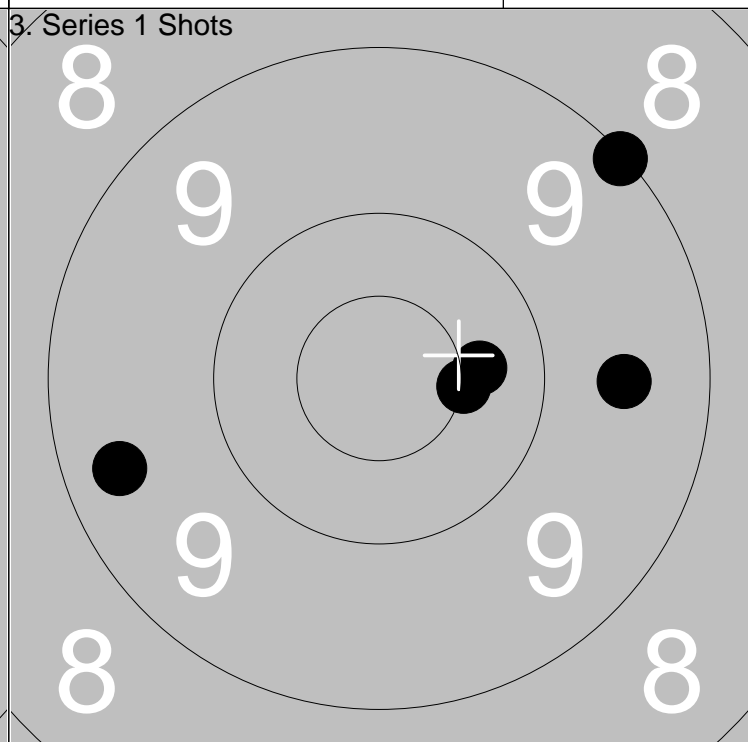
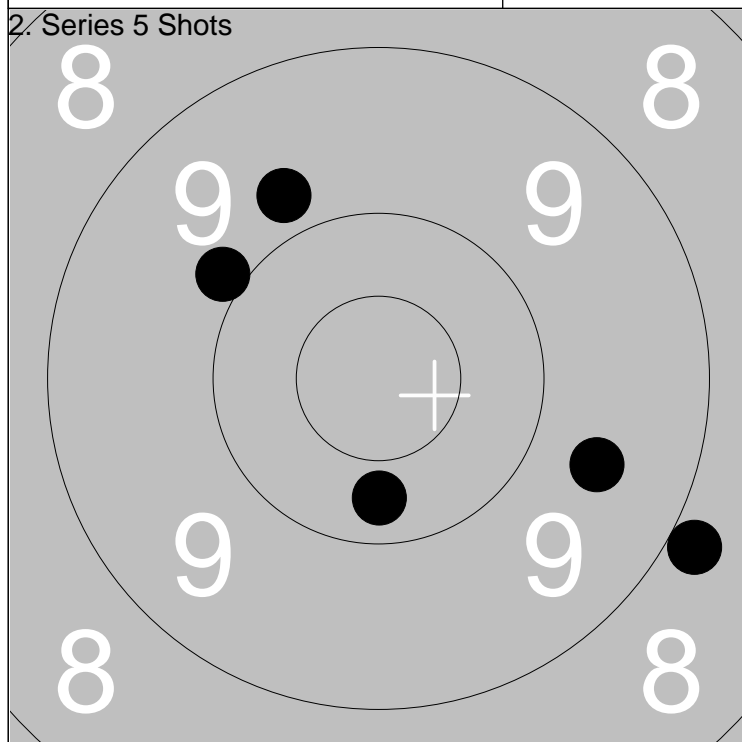

1: 9.9 ↗	Series	45.0
2: 10.3 ↓		
3: 8.9 ↘		
4: 9.8 ↗		
5: 9.6 ↘		
Total		239.0

1: 10.4 →	Series	47.0
2: 9.4 ←		
3: 9.1 ↗		
4: *10.5 →		
5: 9.6 →		
Total		286.0

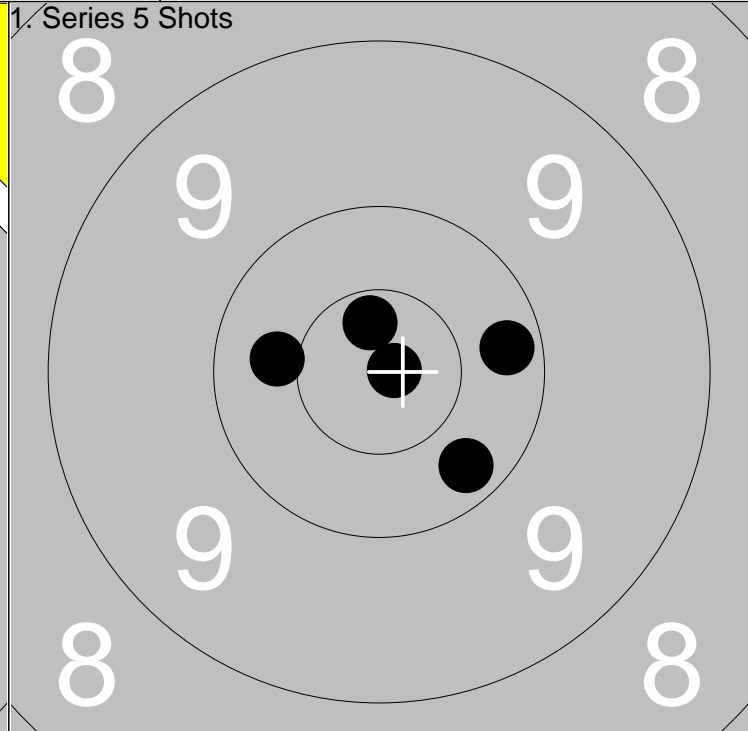
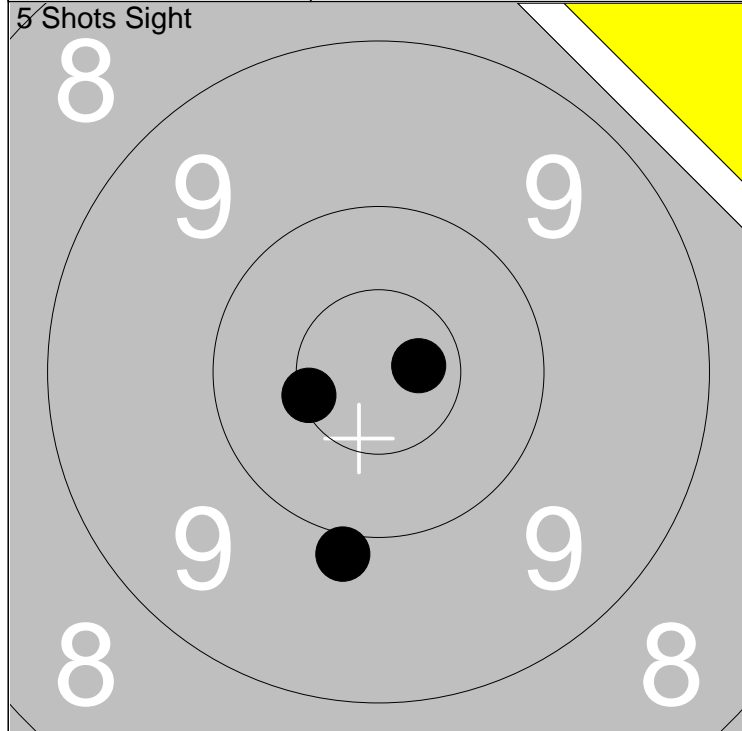

1: *10.5 ↙	Series	29.0
2: *10.7 →		
3: 9.9 ↓		
Total		143.0

1: *10.7 ↑	Series	50.0
2: 10.2 →		
3: 10.2 ↘		
4: 10.4 ←		
5: *10.9 →		
Total		193.0

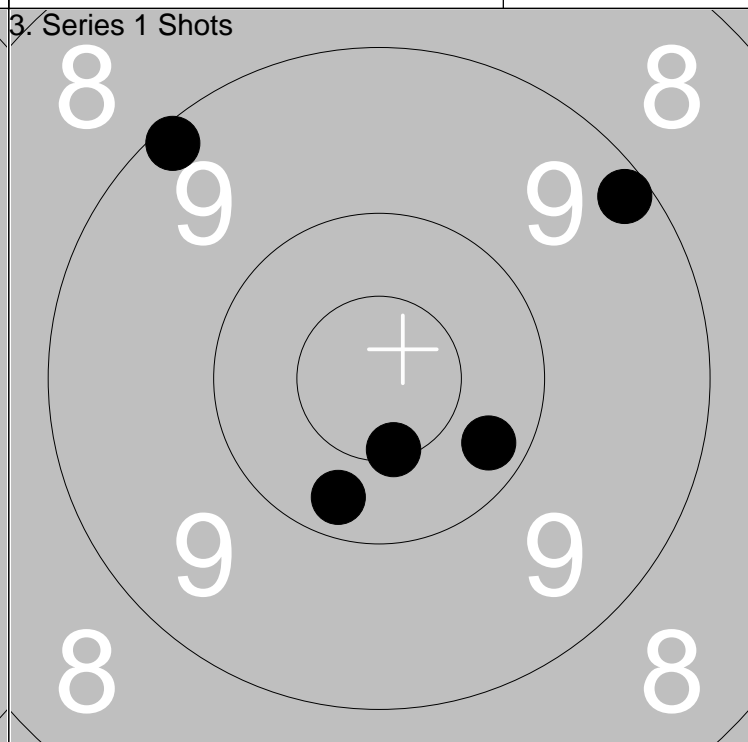
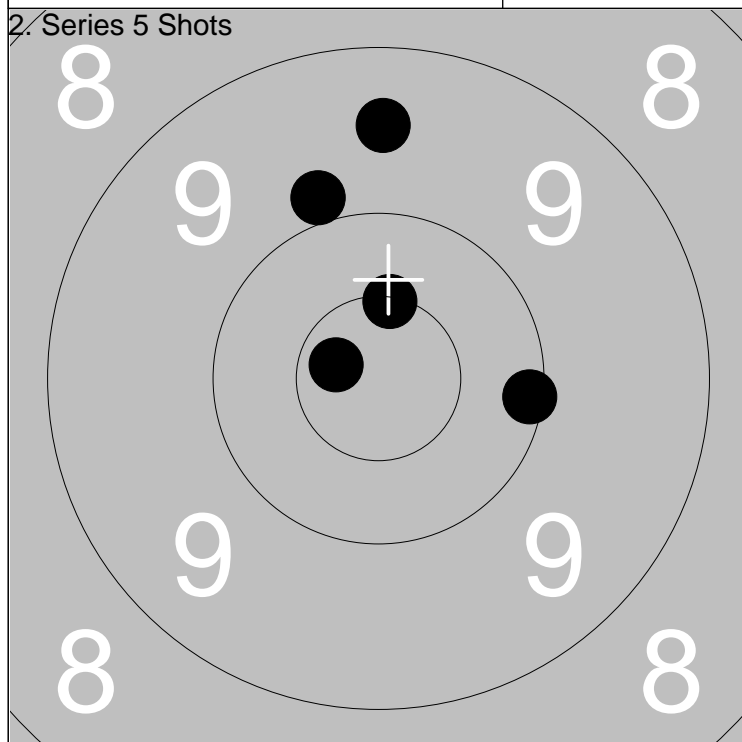

1: 9.5 ↑	Series	48.0
2: 9.9 ↑		
3: *10.5 ↑		
4: *10.7 ↙		
5: 10.1 →		
Total		241.0

1: 10.2 →	Series	48.0
2: 9.1 ↖		
3: 9.2 ↗		
4: *10.5 ↓		
5: 10.2 ↓		
Total		289.0

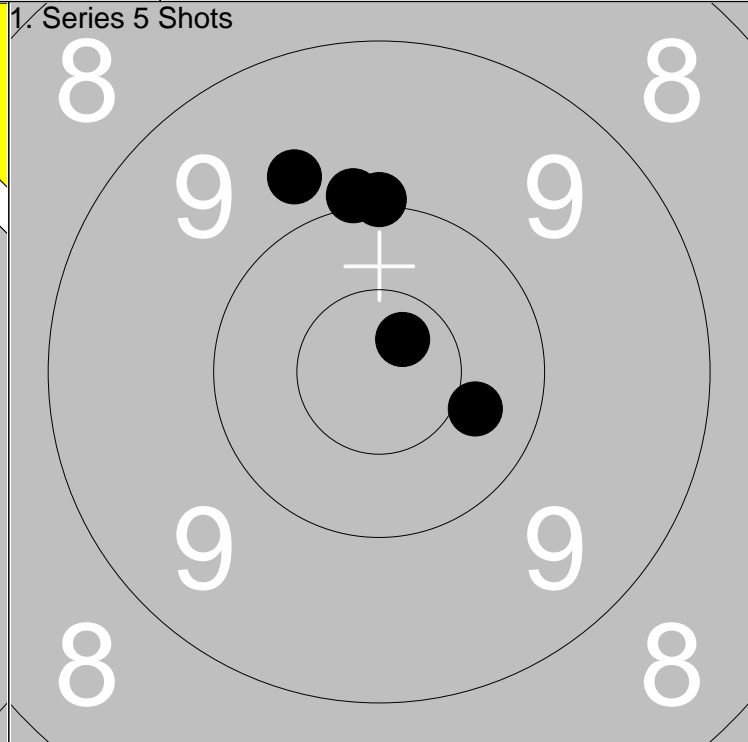
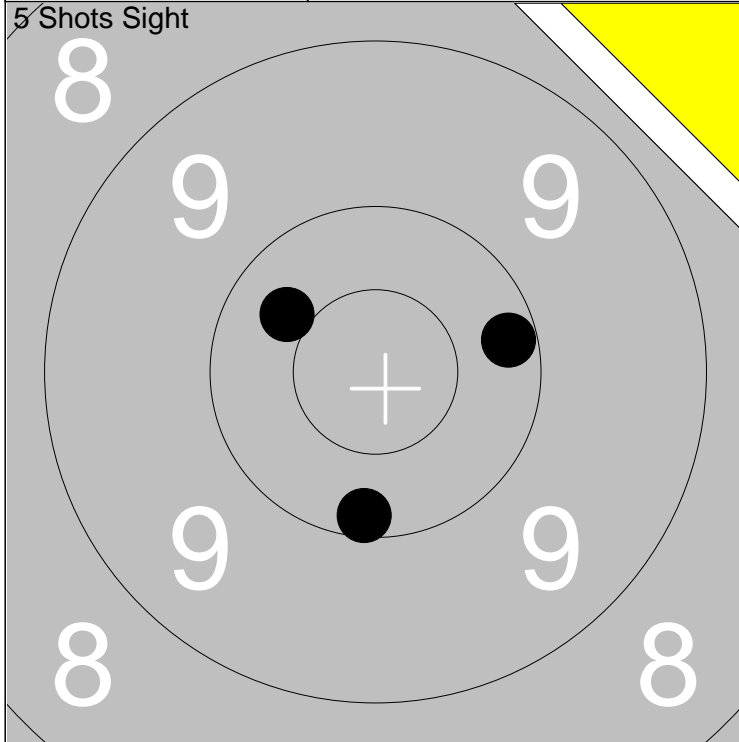

1: 10.4 ↖	Series	30.0
2: 10.2 →		
3: 10.1 ↓		
Total		143.0

1: 9.7 ↗	Series	49.0
2: 10.4 →		
3: 10.0 ↑		
4: 10.0 ↑		
5: *10.7 ↗		
Total		192.0

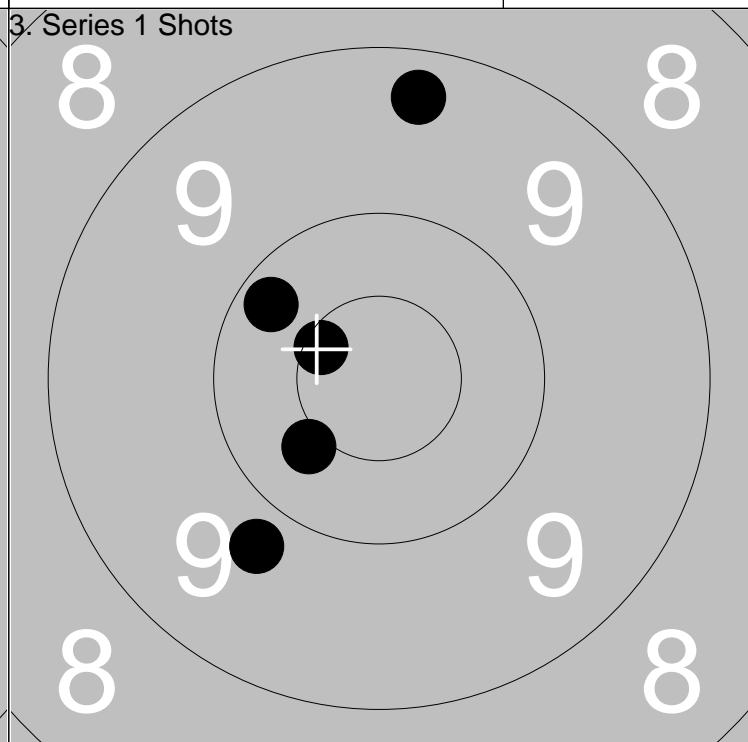
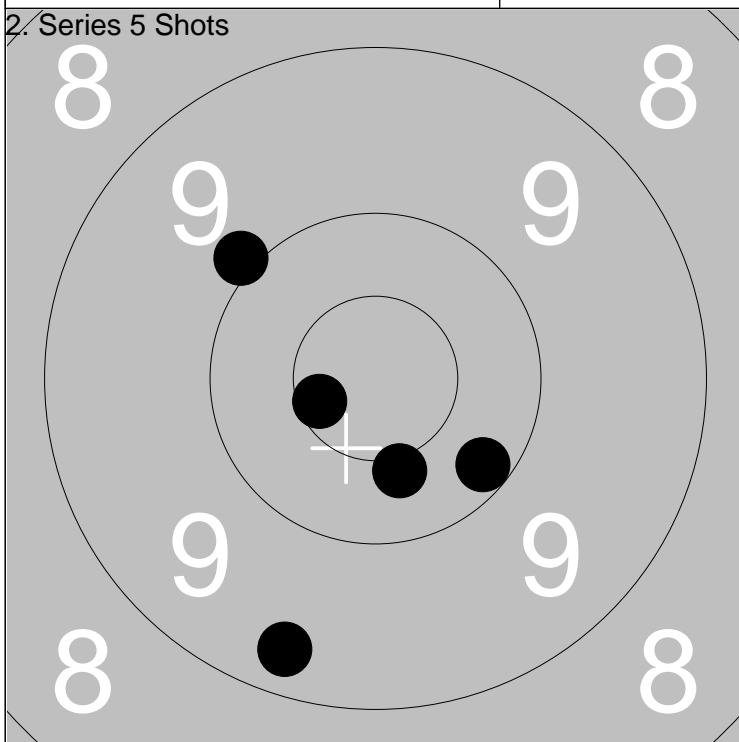

1: 10.2 ↘	Series	48.0
2: *10.6 ↖		
3: 9.3 ↓		
4: *10.4 ↓		
5: 9.9 ↖		
Total		240.0

1: 10.2 ↖	Series	48.0
2: *10.6 ↖		
3: 9.3 ↑		
4: 10.4 ↖		
5: 9.8 ↘		
Total		288.0

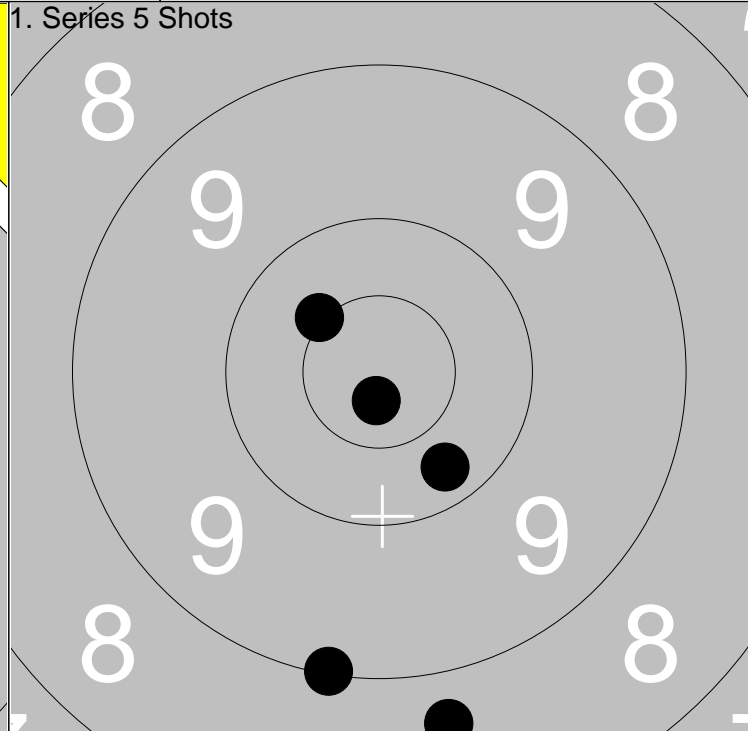
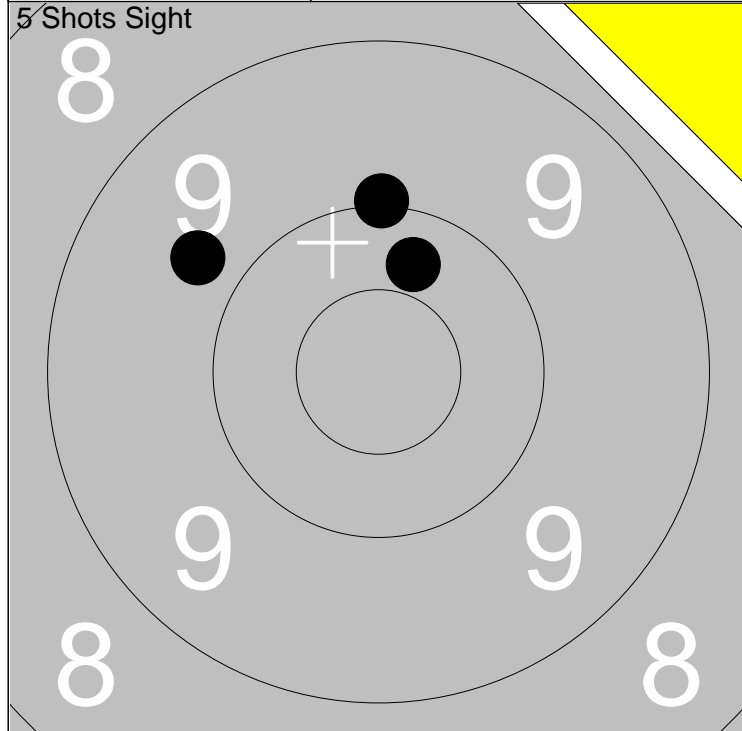

1: 10.0 ↑		Series 29.0
2: 10.3 ↑		Total 143.0
3: 9.7 ↖		

1: 8.7 ↓		Series 47.0
2: 10.3 ↘		Total 190.0
3: *10.5 ↖		
4: 9.0 ↓		
5: *10.8 ↓		

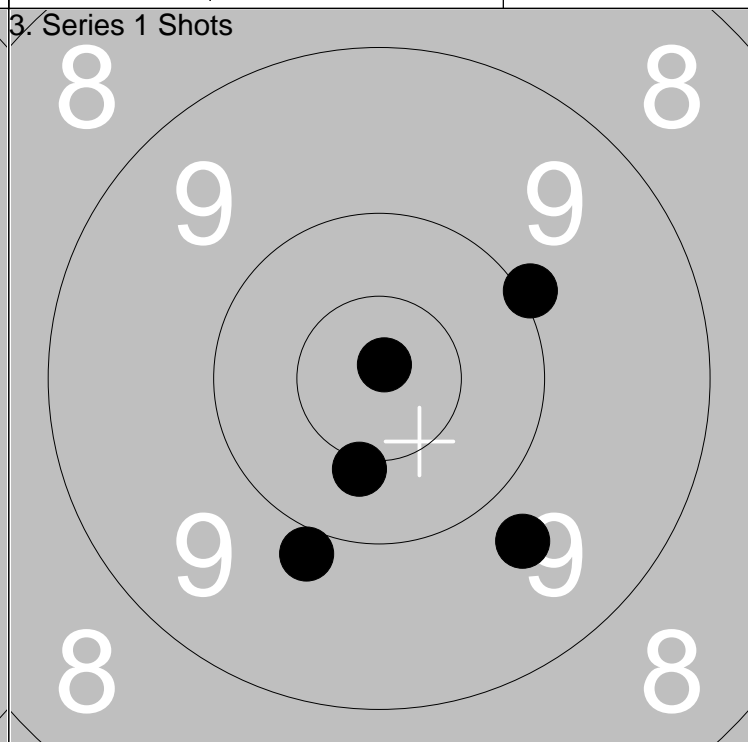
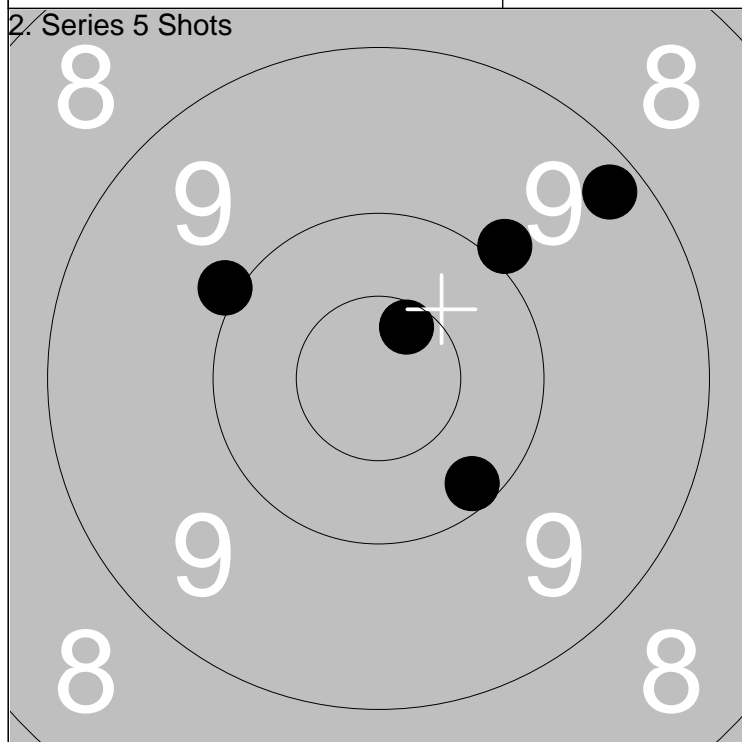

1: 10.0 ↖		Series 48.0
2: *10.6 ↗		Total 238.0
3: 9.2 ↗		
4: 9.9 ↗		
5: 10.2 ↓		

1: 9.9 ↓		Series 48.0
2: *10.4 ↓		Total 286.0
3: 9.7 ↓		
4: *10.9 ↗		
5: 10.0 ↗		

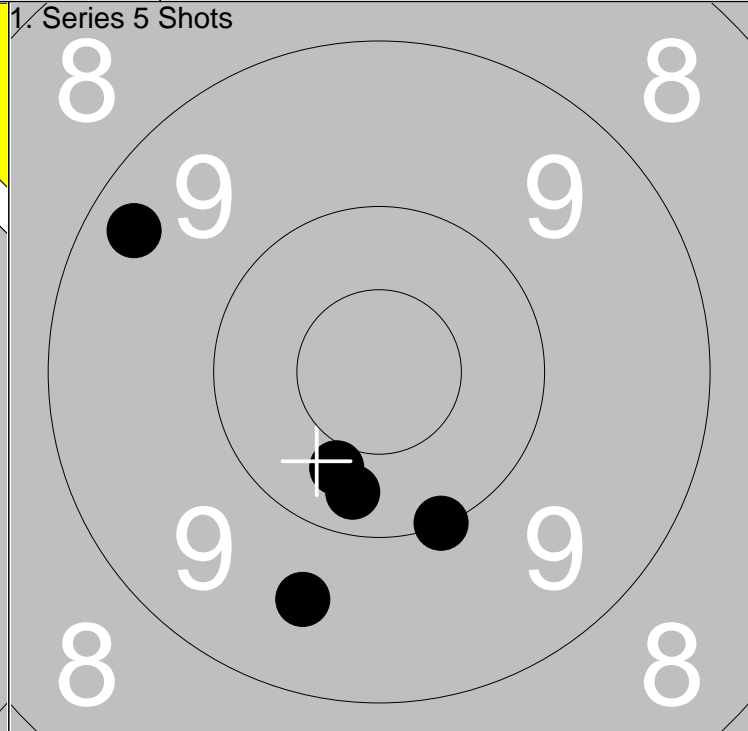
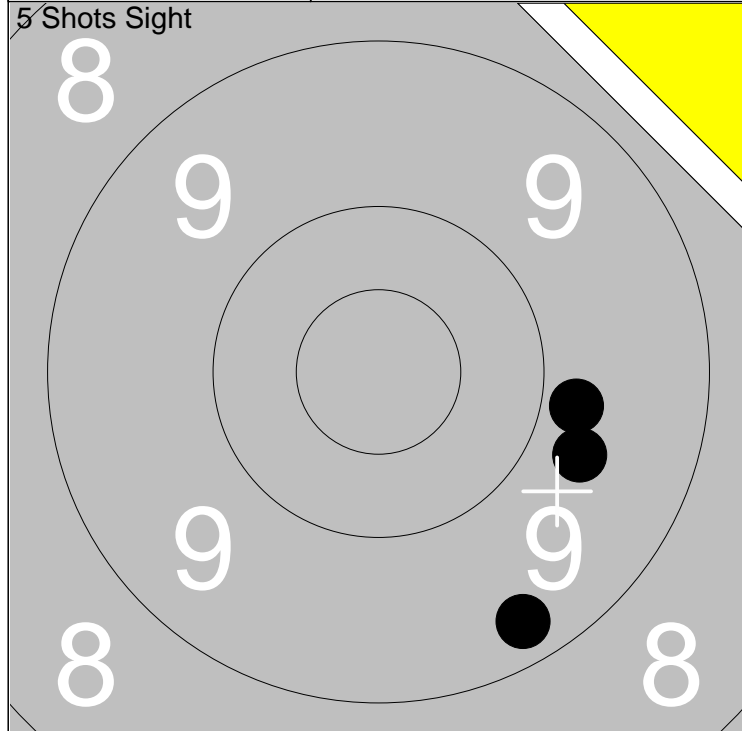

1: 9.8 →	Series	27.0
2: 9.7 →		
3: 9.3 ↓		
Total		136.0

1: 10.4 ↓	Series	48.0
2: 10.3 ↓		
3: 9.3 ↖		
4: 10.0 ↓		
5: 9.6 ↓		
Total		184.0

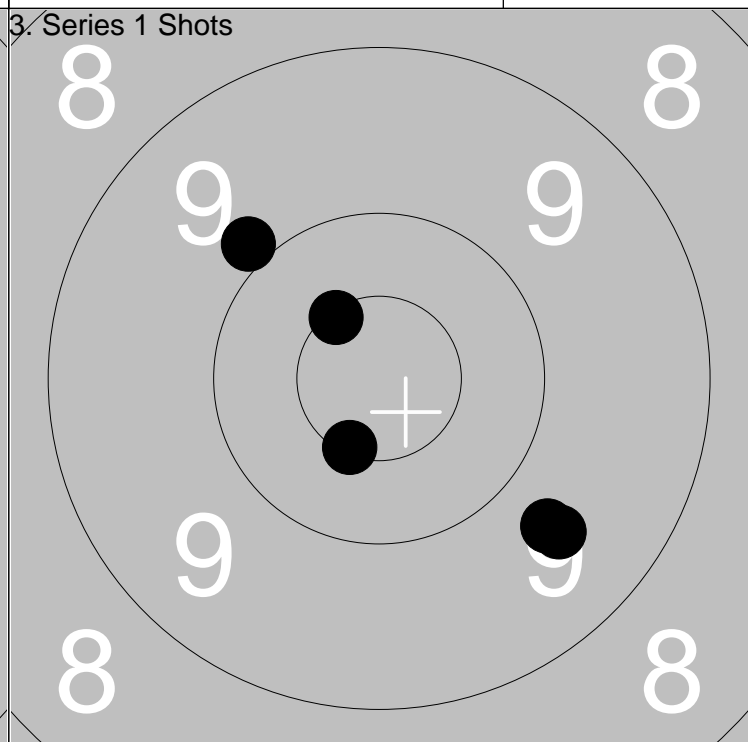
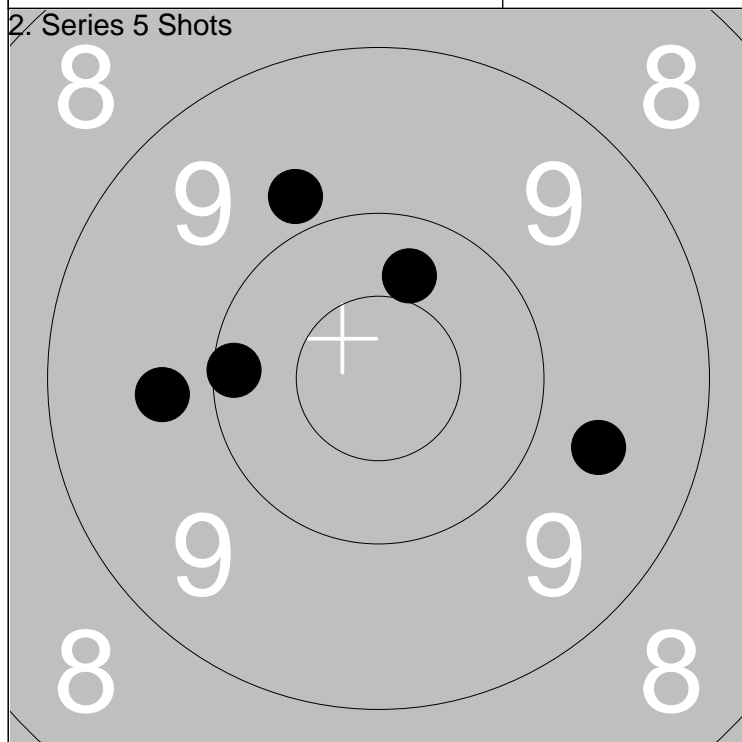

1: 10.4 ↑	Series	47.0
2: 9.8 ↗		
3: 10.1 ←		
4: 9.7 ←		
5: 9.6 →		
Total		231.0

1: 9.9 ↗	Series	47.0
2: *10.5 ↗		
3: 9.6 ↓		
4: 9.7 ↓		
5: *10.5 ↓		
Total		278.0

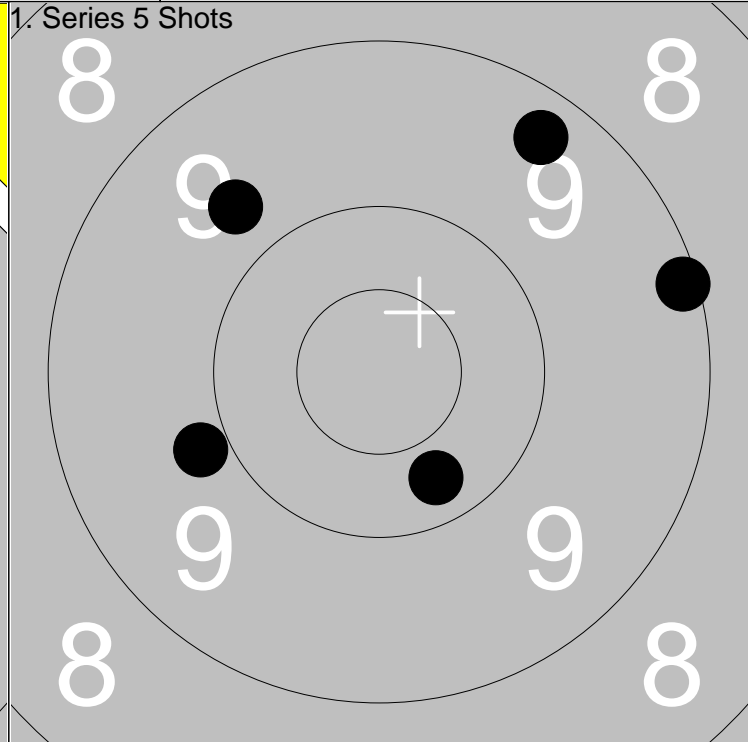
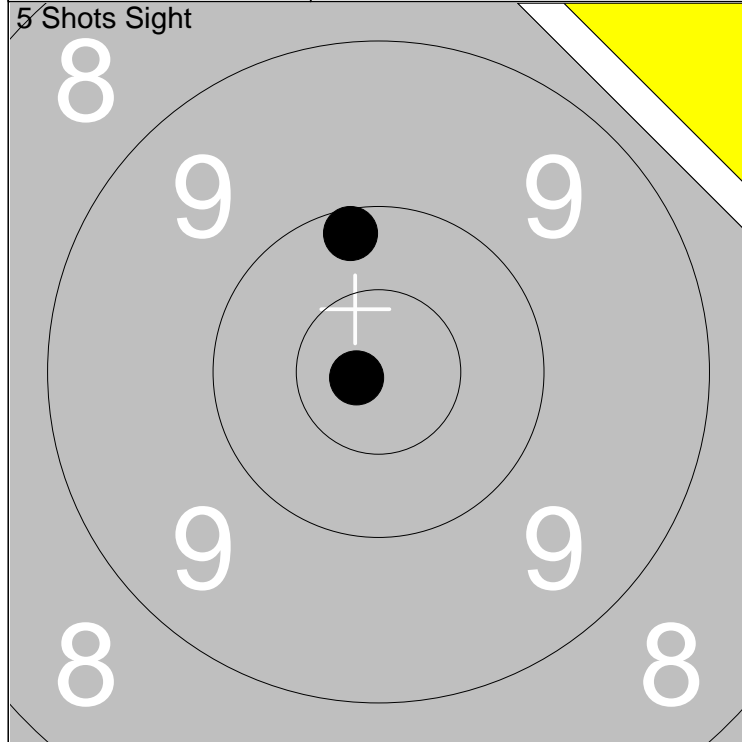

1: *10.8 ↙	Series	20.0
2: 10.2 ↑		
Total		145.0

1: 9.9 ←	Series	46.0
2: 10.3 ↘		
3: 9.1 →	Total	191.0
4: 9.7 ↖		
5: 9.3 ↗		

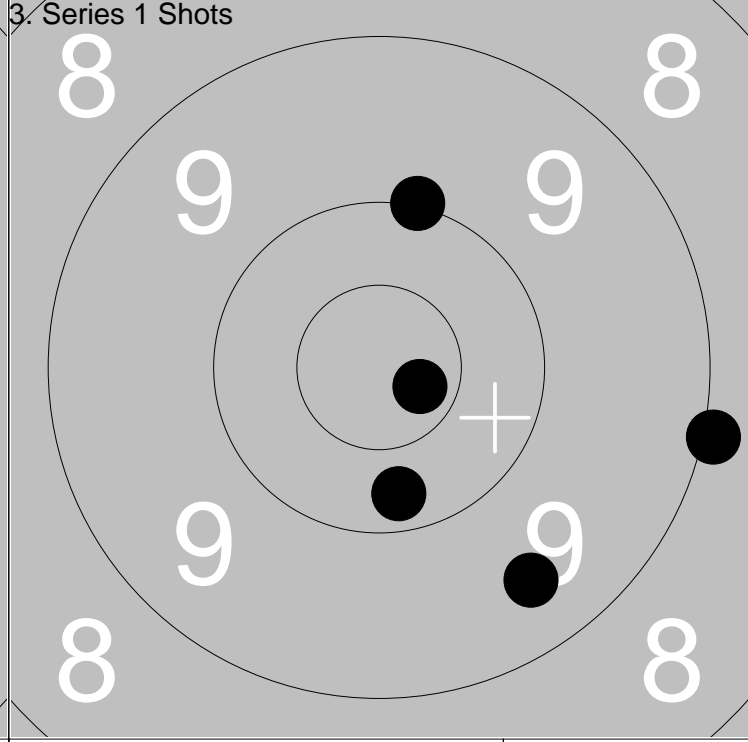
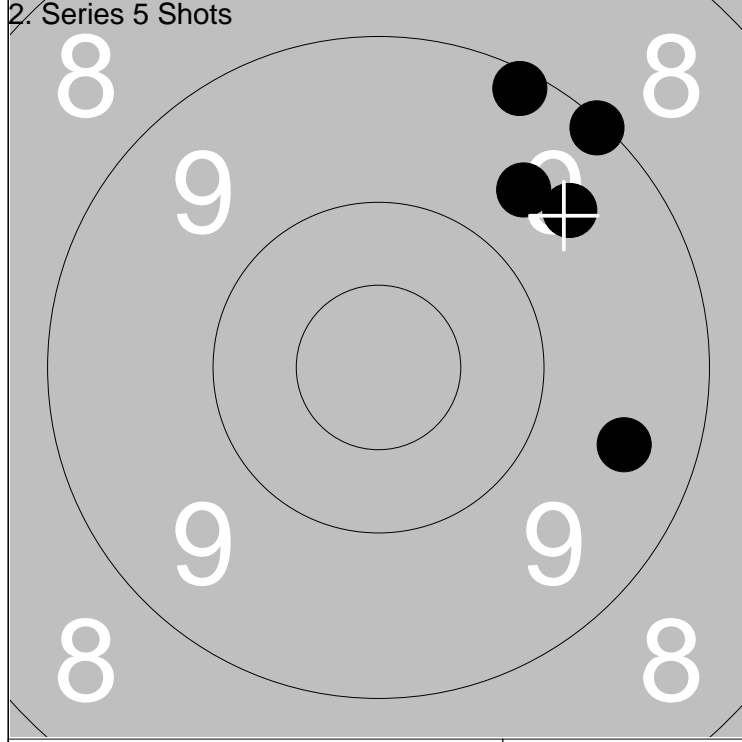

1: 9.1 ↗	Series	45.0
2: 9.1 ↗		
3: 9.5 ↗	Total	236.0
4: 9.6 ↗		
5: 9.5 ➡		

1: 9.0 ➡	Series	48.0
2: 9.5 ↘		
3: 10.0 ↑	Total	284.0
4: 10.2 ↘		
5: *10.7 ➡		

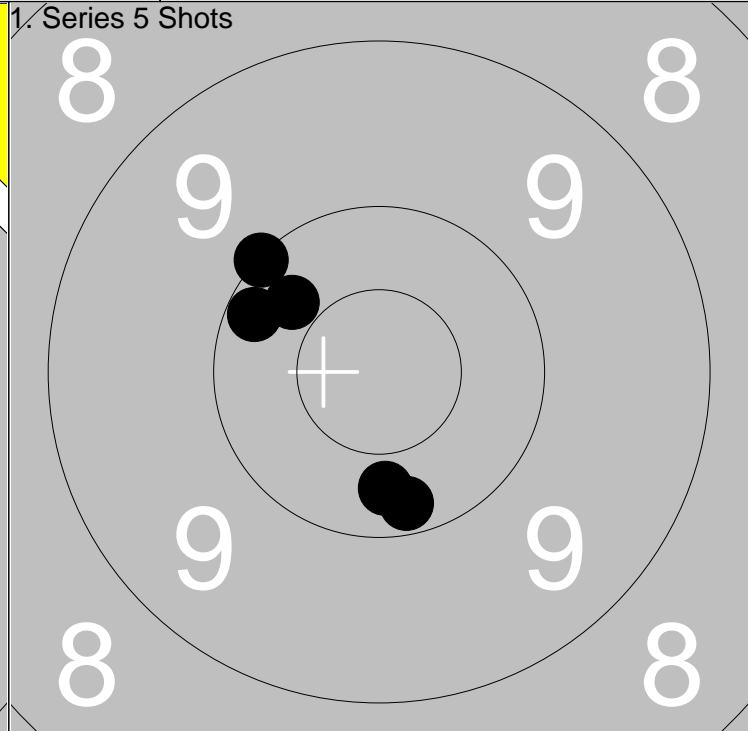
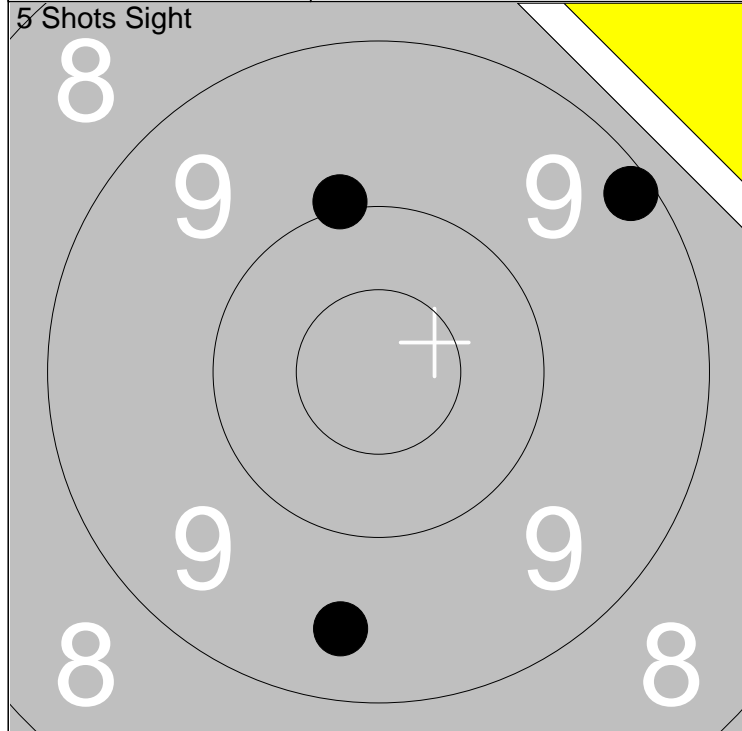

1: 9.5 ↓	Series	28.0
2: 9.2 ↗		
3: 10.0 ↑		
Total		145.0

1: 10.2 ↓	Series	50.0
2: 10.0 ↖		
3: 10.2 ↖		
4: 10.3 ↖		
5: 10.3 ↓		
Total		195.0

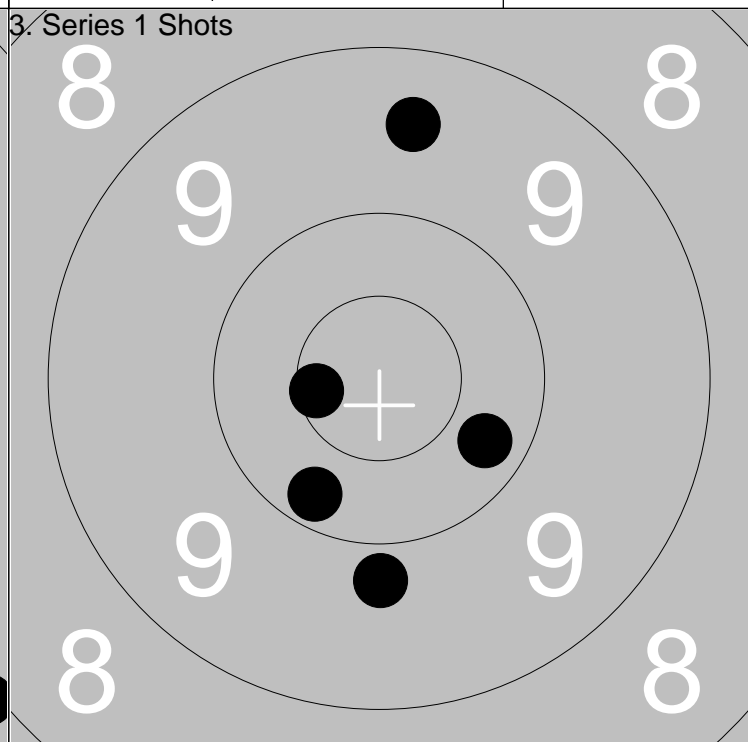
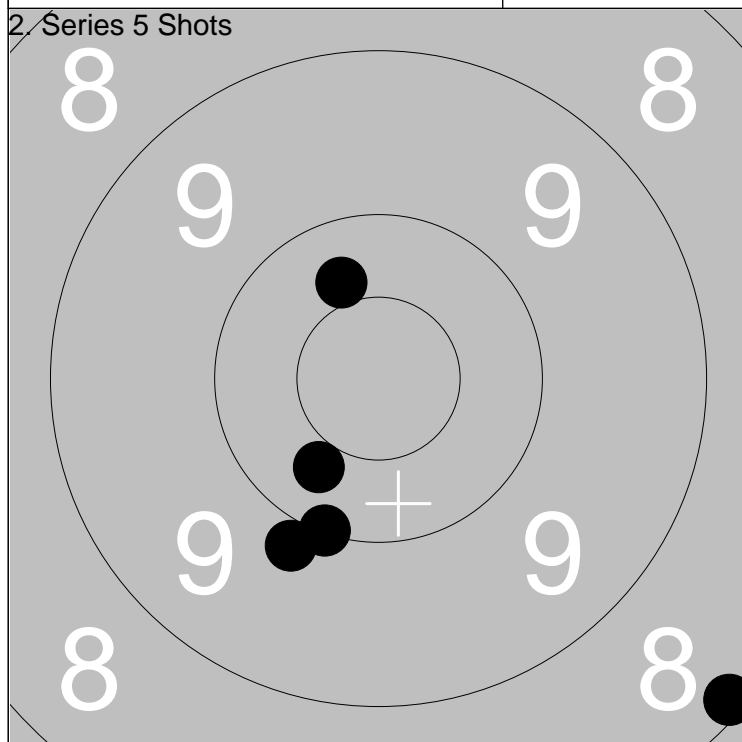

1: 8.1 ↘	Series	47.0
2: 10.0 ↓		
3: 10.4 ↑		
4: 10.3 ↓		
5: 9.9 ↓		
Total		242.0

1: 10.3 ↘	Series	48.0
2: *10.6 ←		
3: 10.2 ↓		
4: 9.5 ↑		
5: 9.8 ↓		
Total		290.0

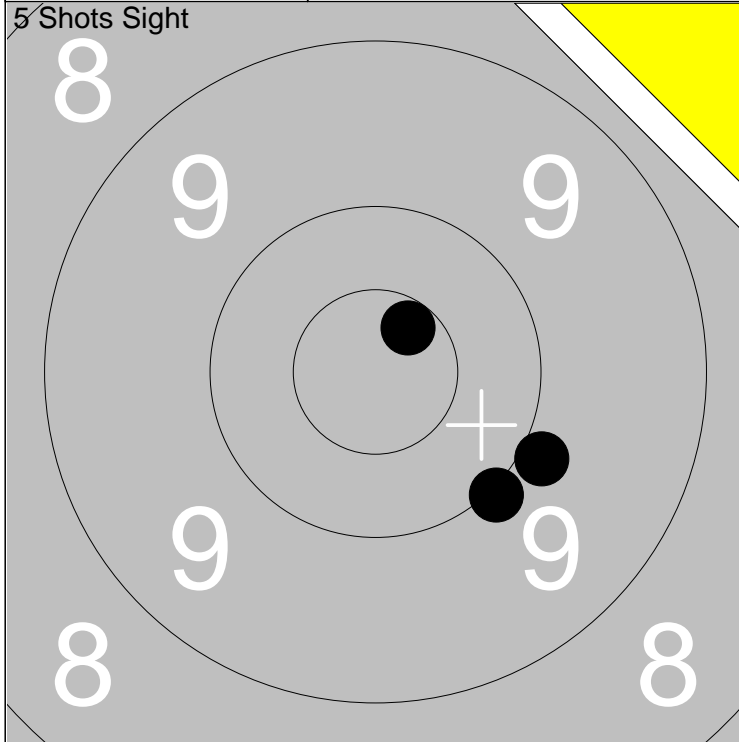

1: 10.0 ↘	Series	29.0
2: *10.6 ↗		
3: 9.9 →		
Total		143.0

1: 9.6 ←	Series	47.0
2: *10.7 ↖		
3: *10.6 ↗		
4: 9.1 ↘		
5: 9.7 →		
Total		190.0

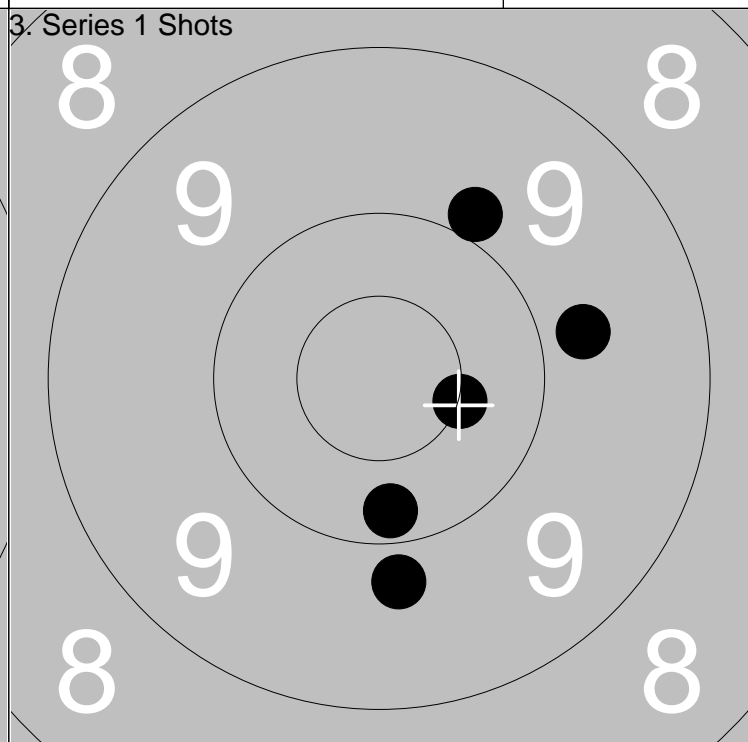
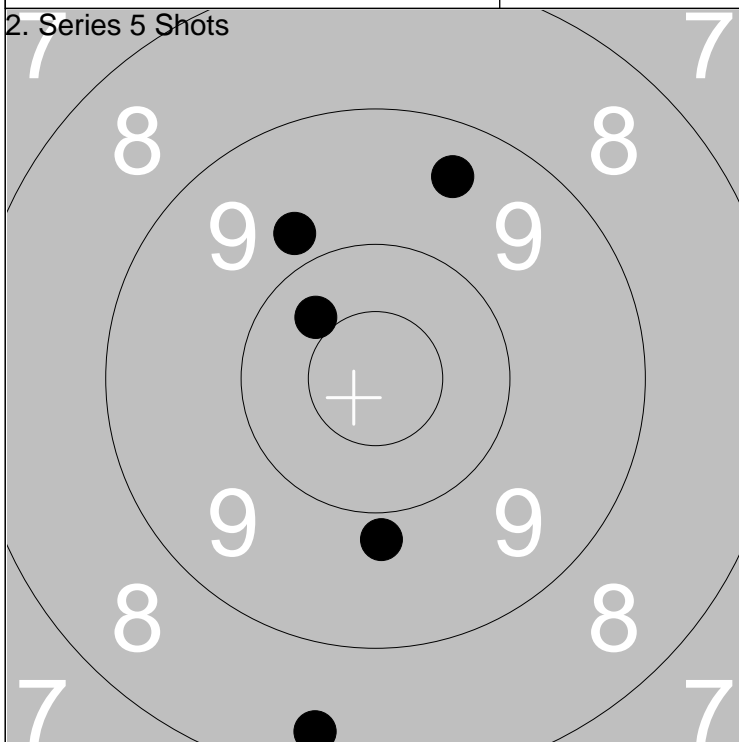

1: 10.4 ↖	Series	45.0
2: 8.4 ↓		
3: 9.8 ↓		
4: 9.8 ↖		
5: 9.4 ↗		
Total		235.0

1: 9.9 ↗	Series	47.0
2: 10.2 ↓		
3: 9.8 ↓		
4: 9.8 →		
5: *10.5 →		
Total		282.0

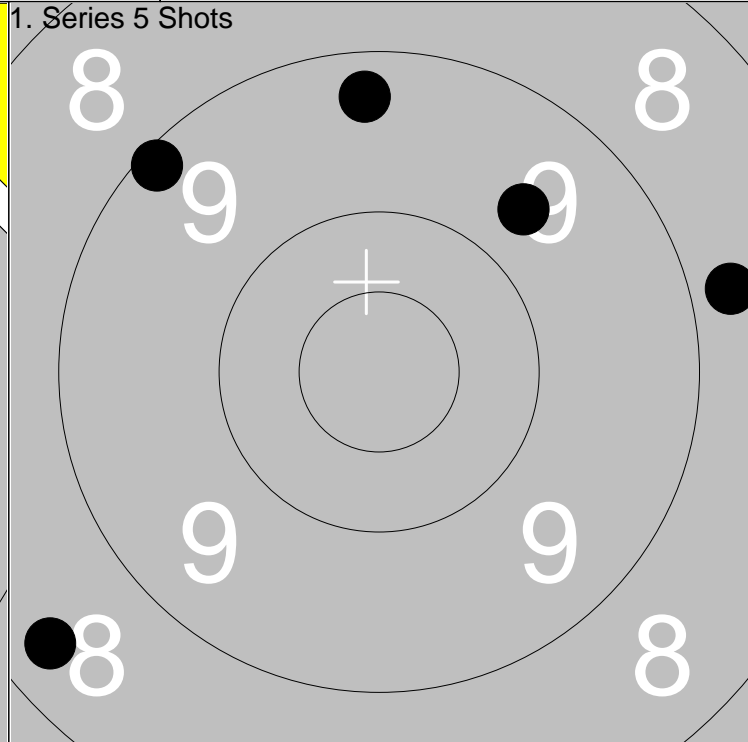
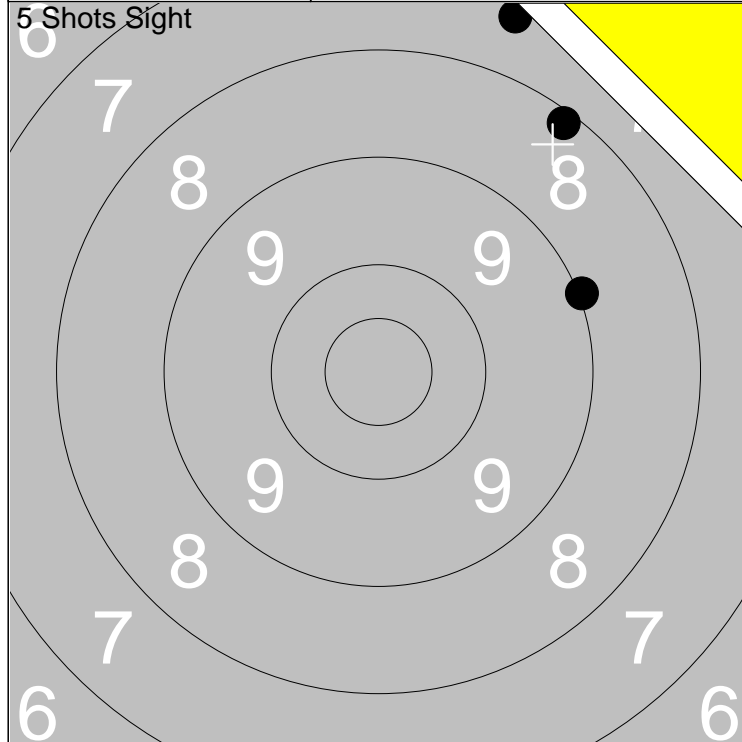

1: 9.0 →
2: 7.5 ↑
3: 8.1 ↗
Series 24.0
Total 142.0

1: 9.1 ↖
2: 9.3 ↑
3: 8.4 ↙
4: 8.8 →
5: 9.7 ↗
Series 43.0
Total 185.0

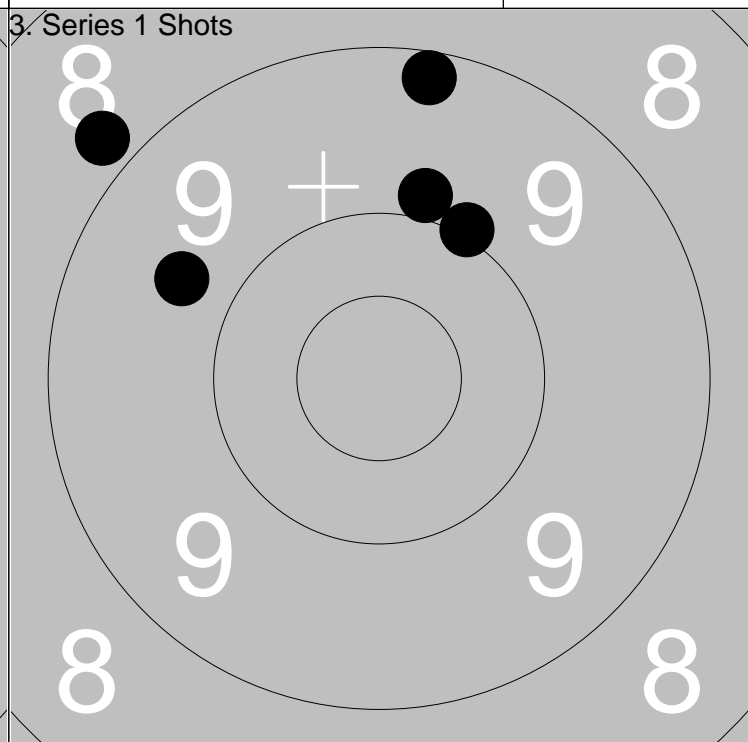
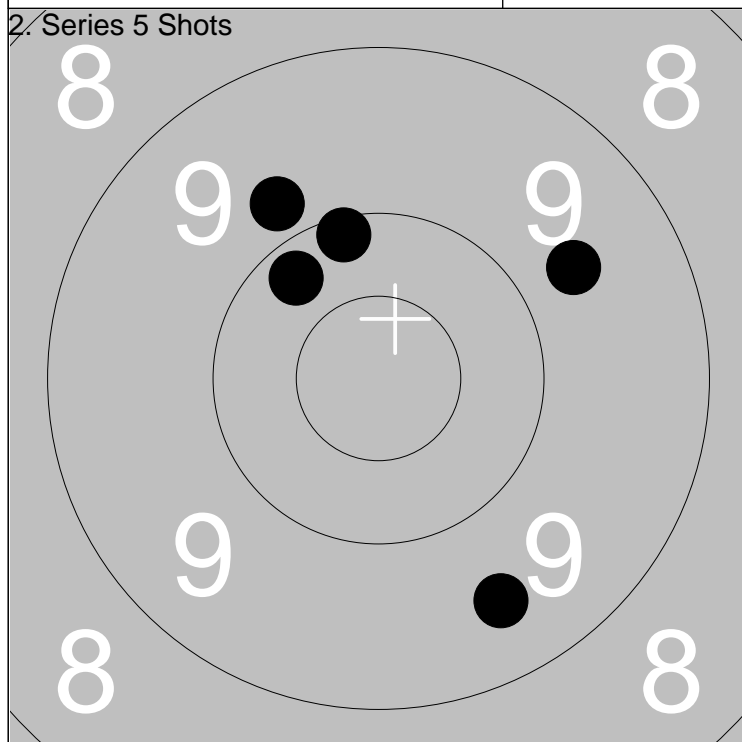

1: 9.5 ↓
2: 10.2 ↖
3: 9.7 →
4: 9.8 ↑
5: 10.1 ↑
Series 47.0
Total 232.0

1: 9.7 ↖
2: 10.0 ↗
3: 8.8 ↖
4: 9.9 ↑
5: 9.2 ↑
Series 45.0
Total 277.0

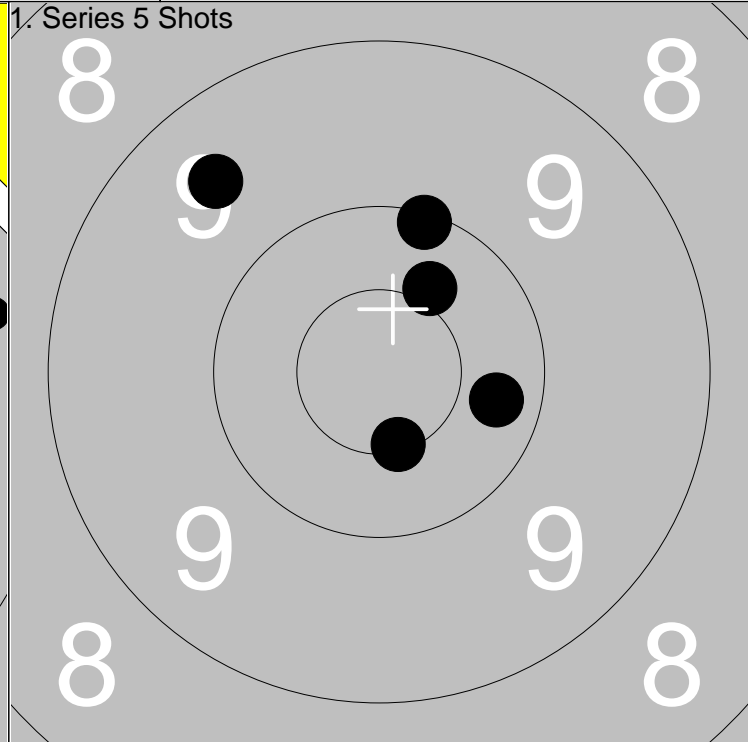
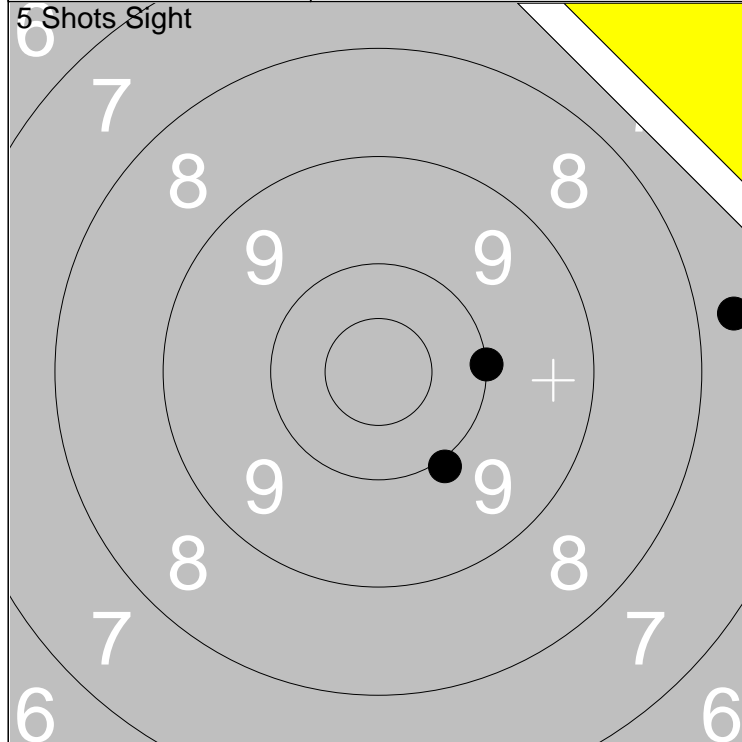

1: 7.7 →		Series	27.0
2: 10.0 →		Total	140.0
3: 10.0 ↓			

1: 9.5 ↖		Series	49.0
2: 10.4 ↗		Total	189.0
3: *10.5 ↓			

4: 10.1 ↑		Series	48.0
5: 10.3 →		Total	284.0

1: 10.2 ↖		Series	47.0
2: 10.1 ↑		Total	236.0
3: 10.2 ↑			

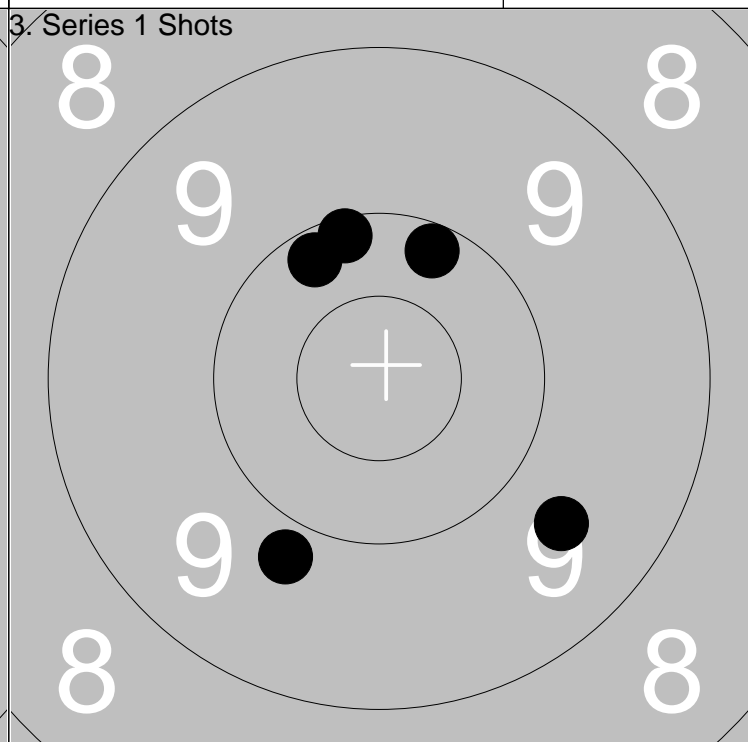
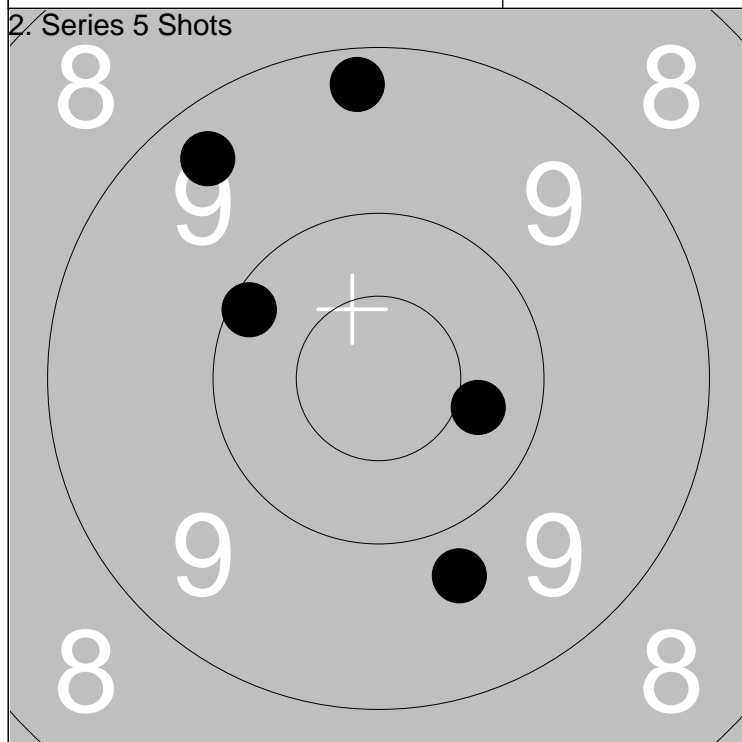

1: 9.7 ↓		Series	47.0
2: 10.4 →		Total	236.0
3: 9.3 ↗			

4: 9.2 ↑		Series	48.0
5: 10.1 ↖		Total	284.0

1: 10.2 ↖		Series	48.0
2: 10.1 ↑		Total	284.0
3: 10.2 ↑			

4: 9.8 ↓		Series	47.0
5: 9.6 ↘		Total	236.0

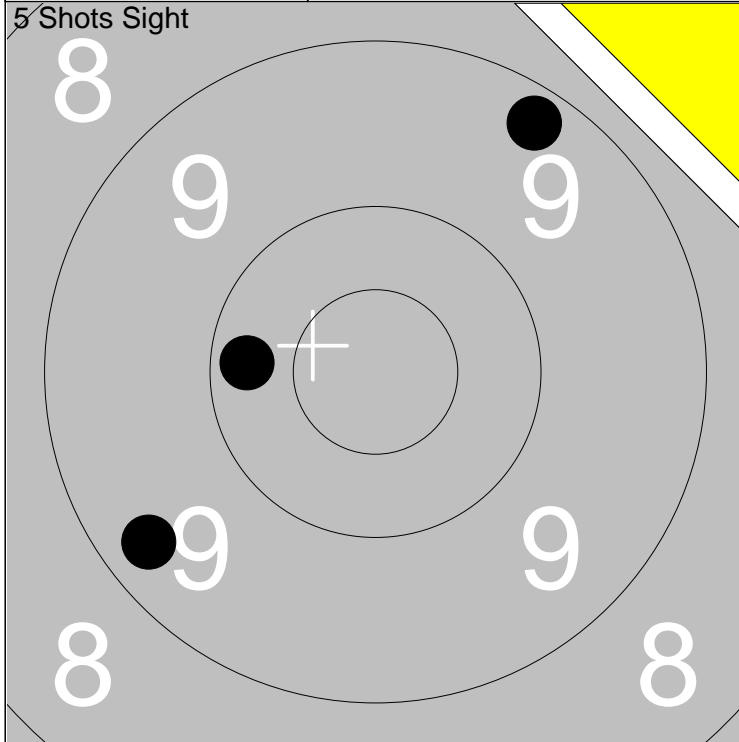

1: 10.2 ←	Series	28.0
2: 9.2 ↗		
3: 9.3 ↙		
Total		140.0

1: 10.3 ↑	Series	50.0
2: 10.1 ↓		
3: 10.0 ↓		
Total		190.0

4: *10.7 ←	Series	44.0
5: 10.3 ↙		
Total		

1: 8.1 ↖	Series	42.0
2: 7.3 ↓		
3: 9.2 ↓		
Total		232.0

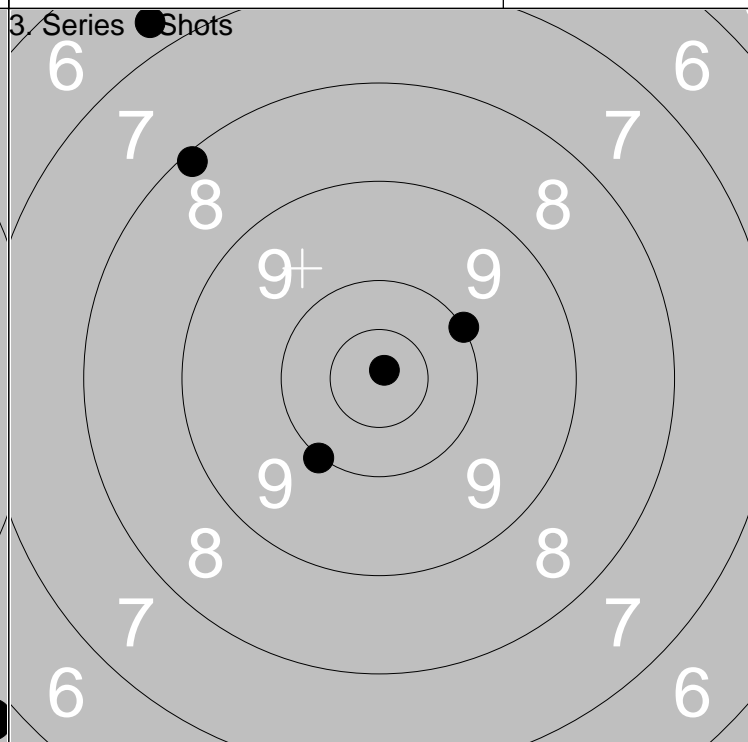
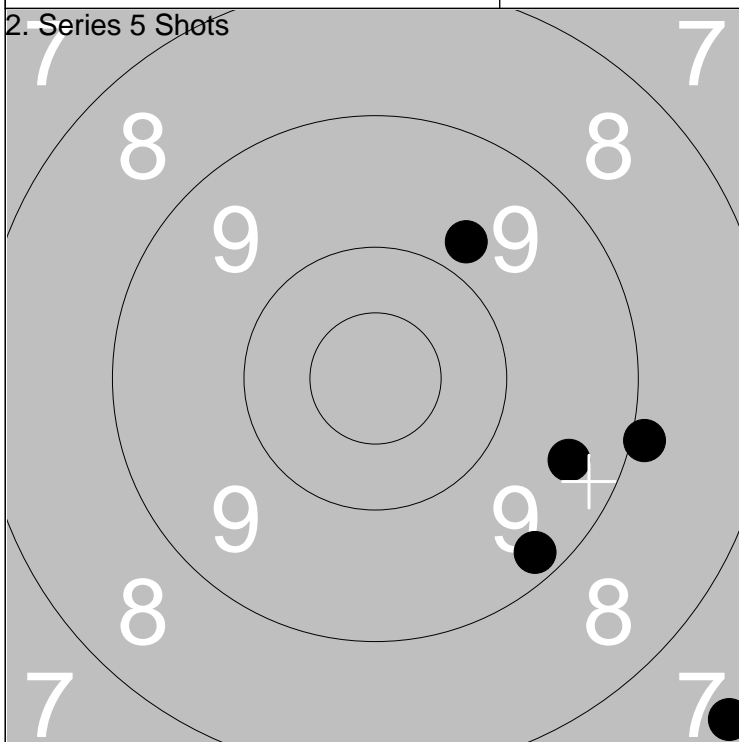

1: 9.8 ↗	Series	42.0
2: 7.3 ↓		
3: 9.2 ↓		
Total		232.0

4: 9.4 ↓	Series	44.0
5: 8.9 →		
Total		

1: 8.1 ↖	Series	44.0
2: 10.0 ↓		
3: 6.7 ↖		
Total		276.0

4: *10.9 ↗	Series	44.0
5: 10.0 ↗		
Total		

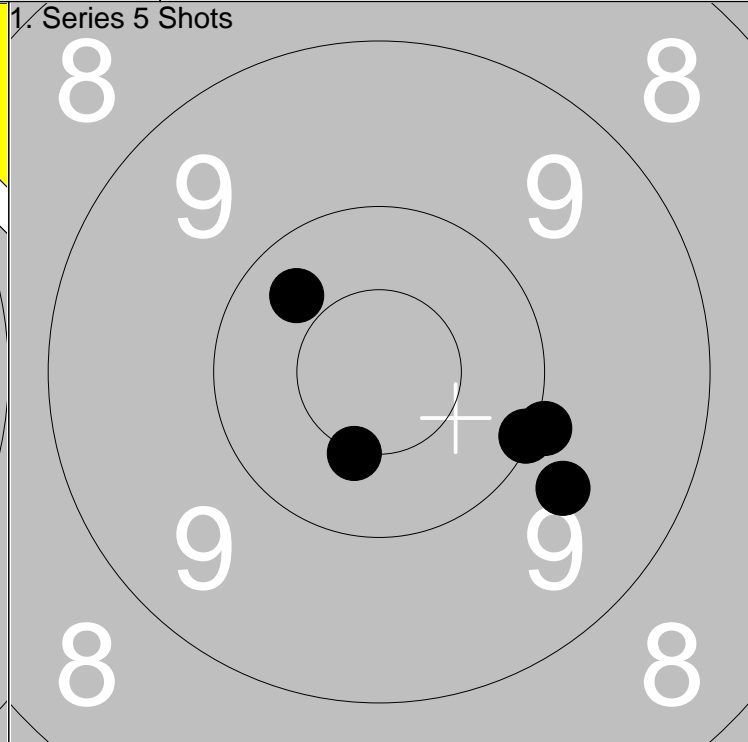
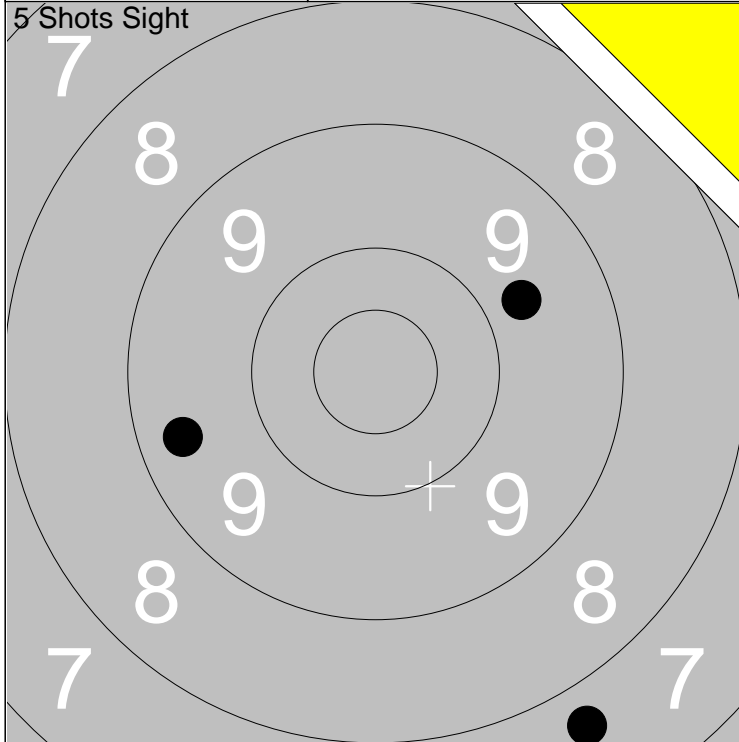

1: 7.7 ↘	Series 25.0
2: 9.7 ↗	
3: 9.4 ←	
Total 137.0	

1: 10.3 ↖	Series 49.0
2: *10.5 ↓	
3: 10.0 →	
4: 9.7 ↘	
5: 10.1 →	
Total 186.0	

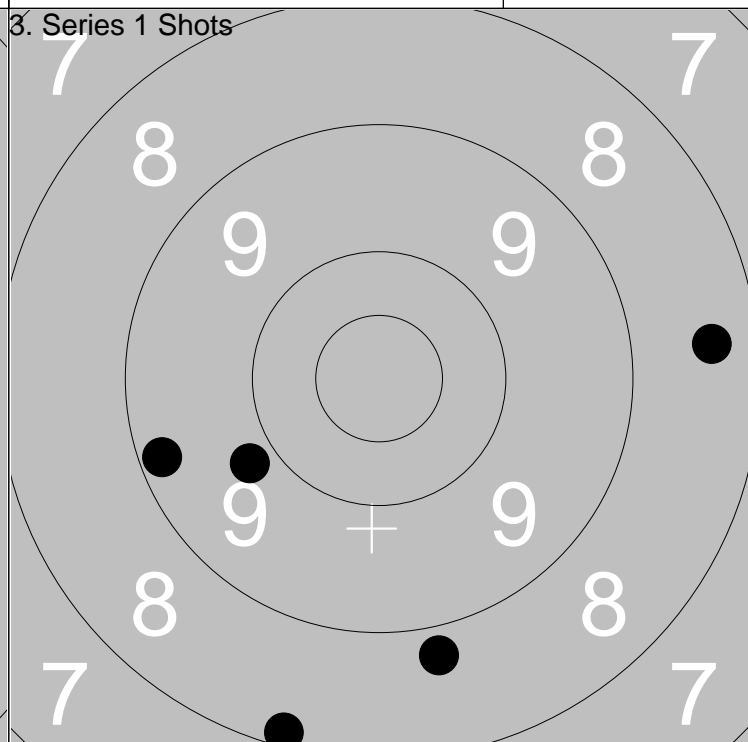
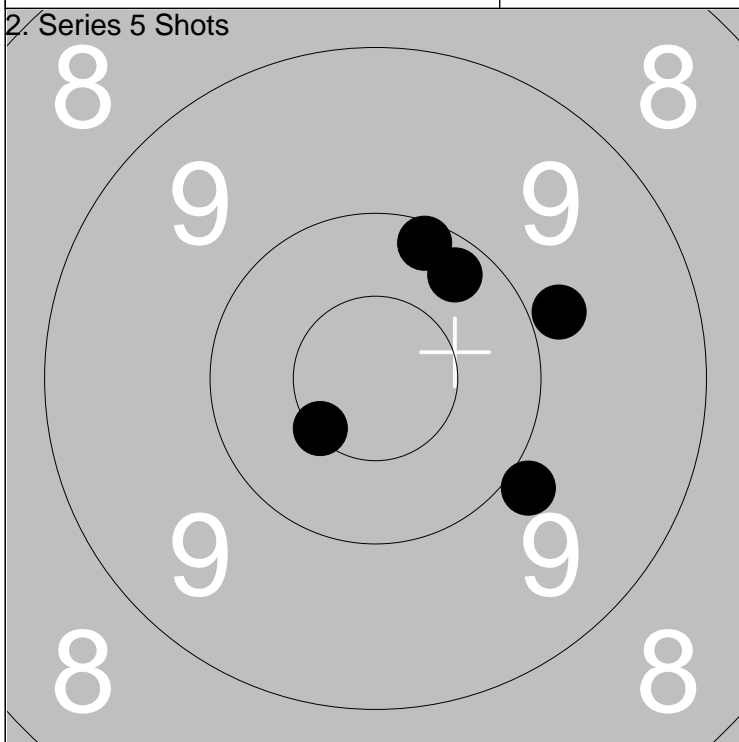

1: 9.8 →	Series 48.0
2: 10.2 ↗	
3: *10.5 ↙	
4: 9.9 ↘	
5: 10.1 ↗	
Total 234.0	

1: 8.4 →	Series 42.0
2: 8.8 ↓	
3: 9.2 ←	
4: 8.1 ↓	
5: 9.8 ↙	
Total 276.0	

Relay 6	Lane 24	Elina Johansson	
-------------------	-------------------	------------------------	--

300m	Ale	C	No
------	-----	---	----

2013-07-07	Tavelträffen A 2013	Ramselefors SKF
------------	---------------------	-----------------

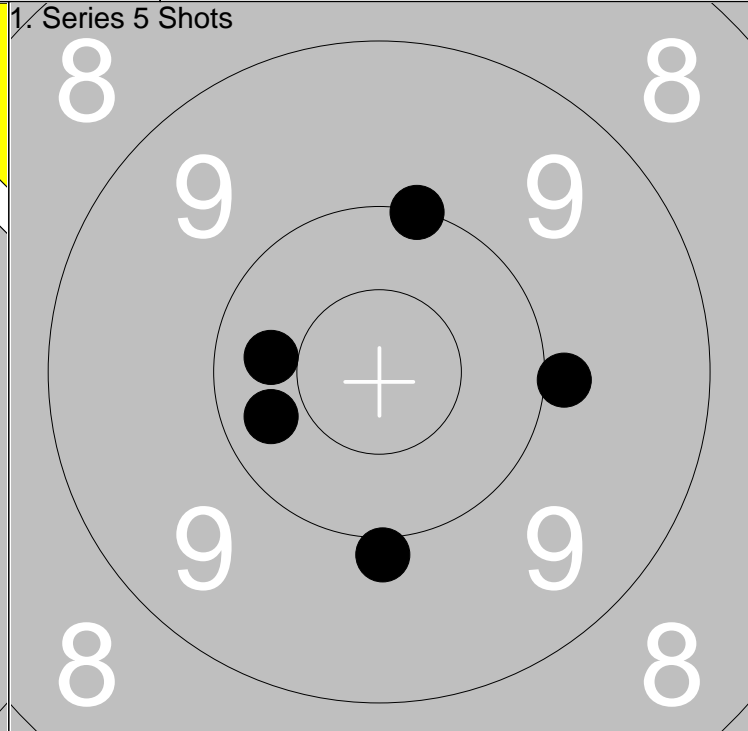
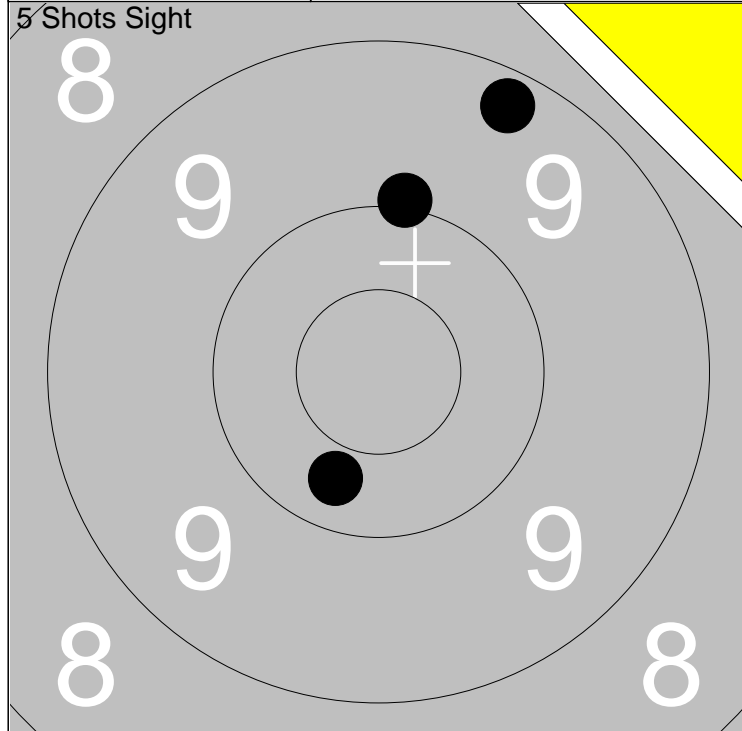

1: 10.0 ↑	Series	29.0
2: 9.2 ↗		
3: 10.3 ↓		
Total		132.0

1: 10.3 ←	Series	48.0
2: 9.9 →		
3: 9.9 ↓		
4: 10.0 ↑		
5: 10.3 ←		
Total		180.0

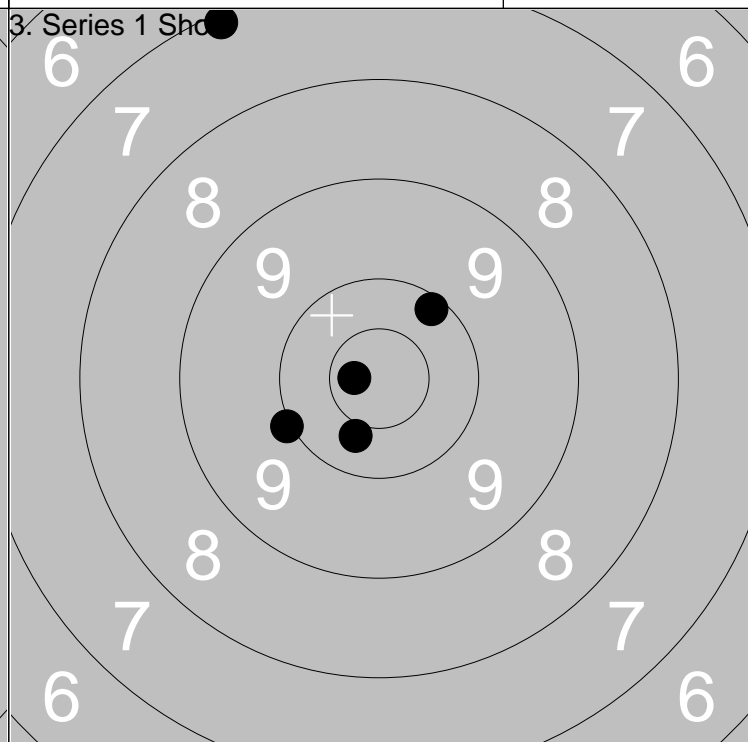
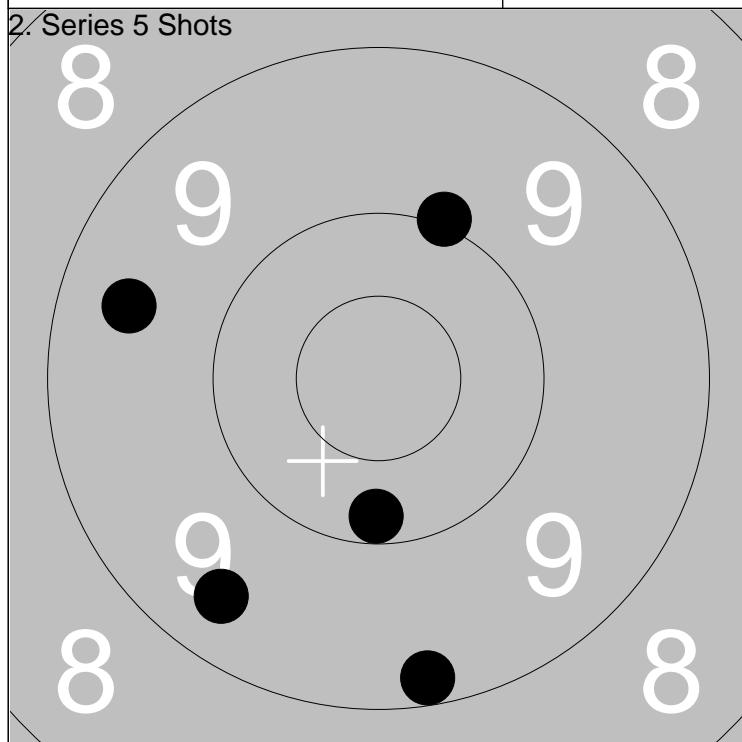

1: 10.2 ↓	Series	47.0
2: 9.2 ↓		
3: 9.4 ↘		
4: 9.5 ←		
5: 10.0 ↗		
Total		227.0

1: *10.7 ←	Series	47.0
2: 7.1 ↖		
3: 10.4 ↓		
4: 10.1 ↗		
5: 10.0 ←		
Total		274.0