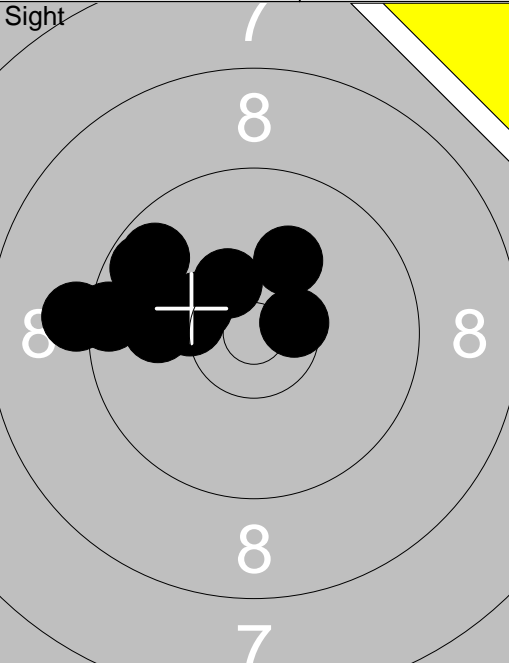
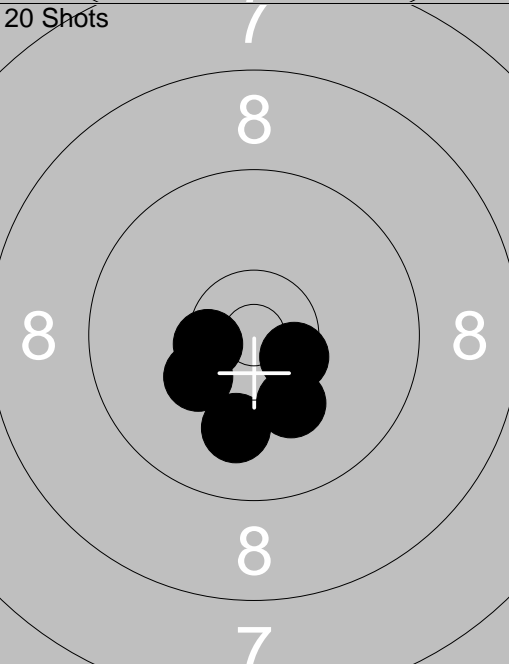
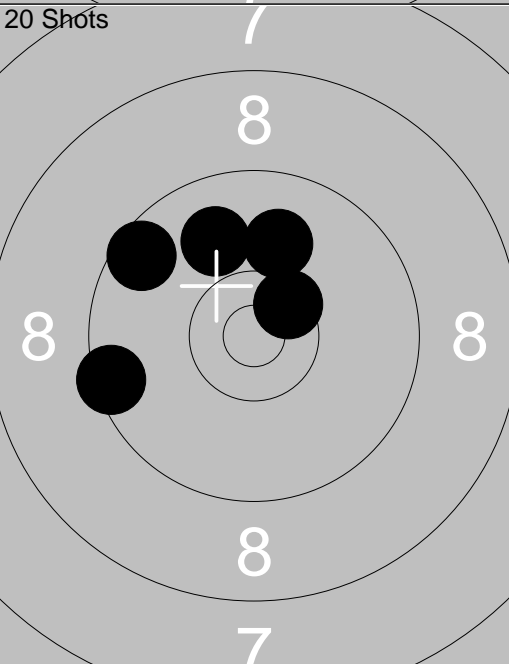
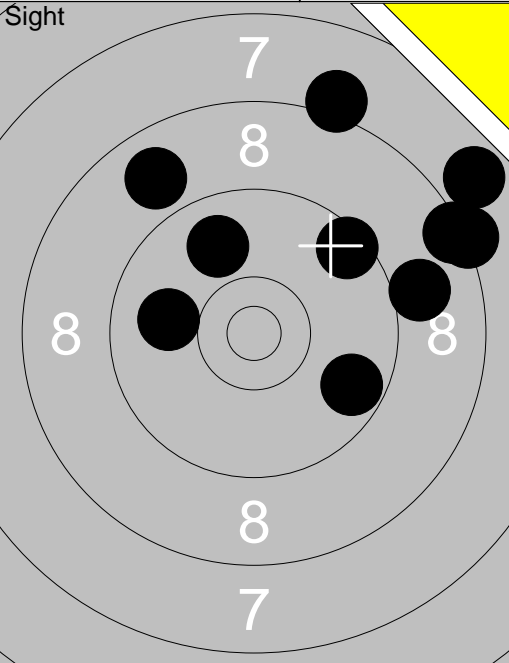
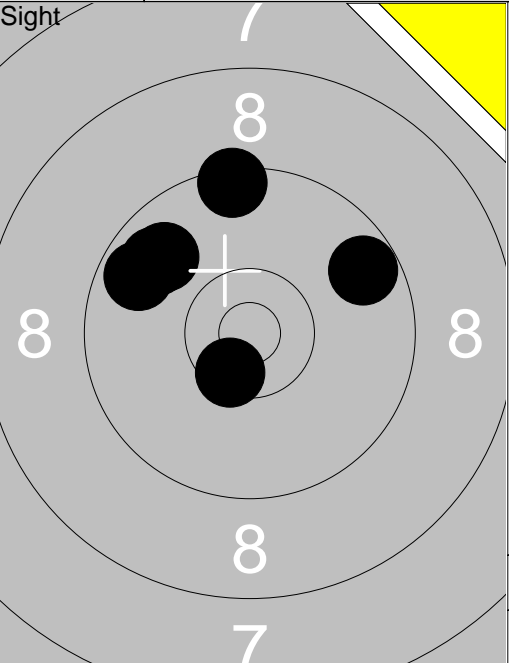
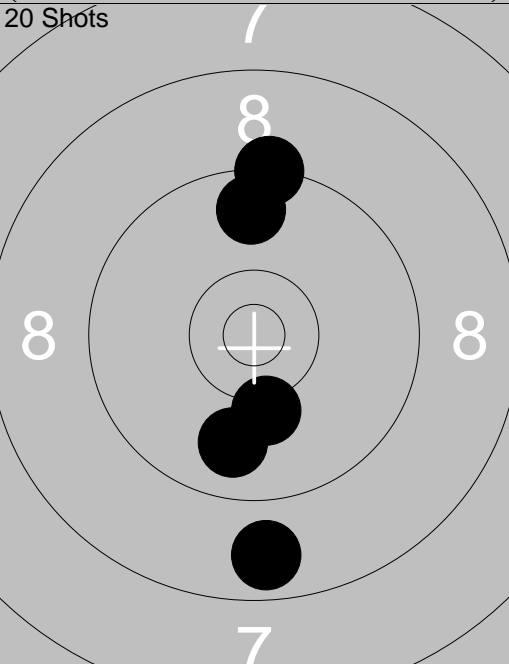
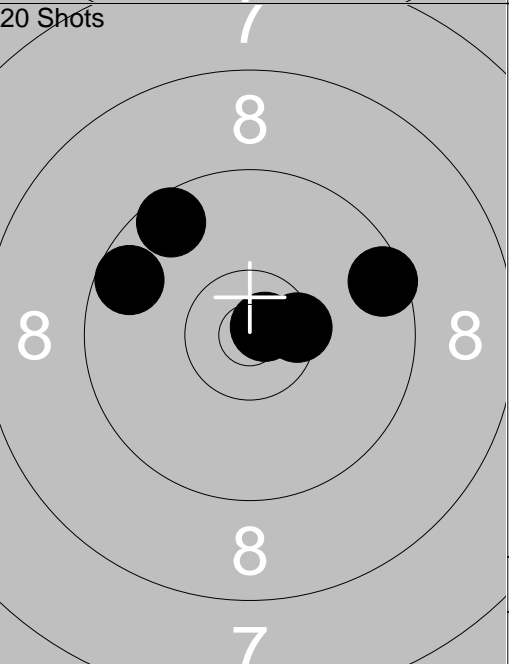
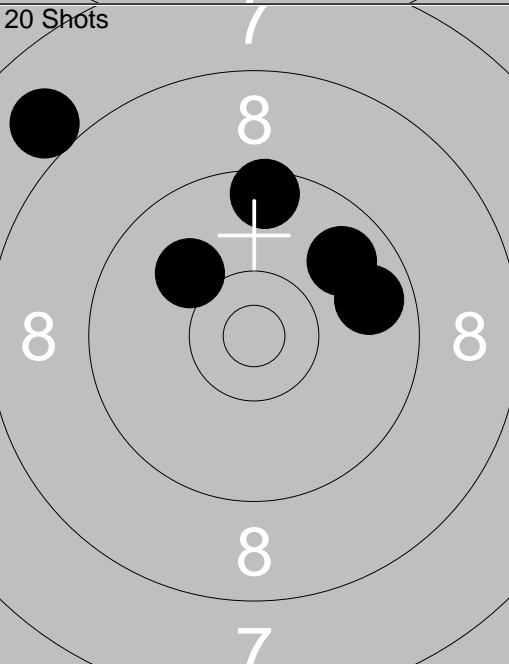
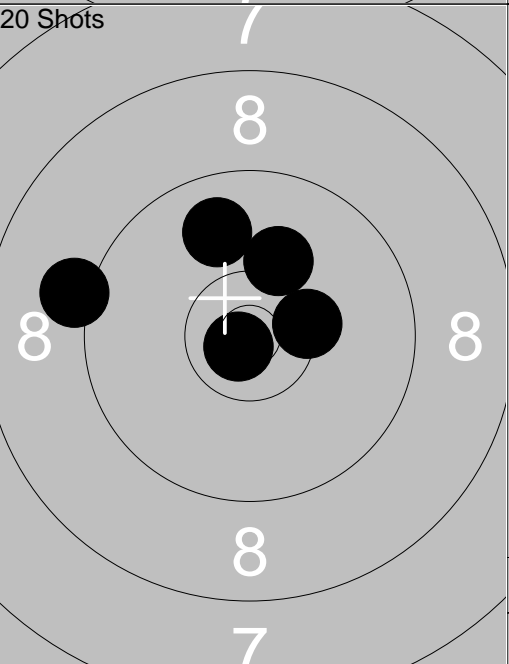
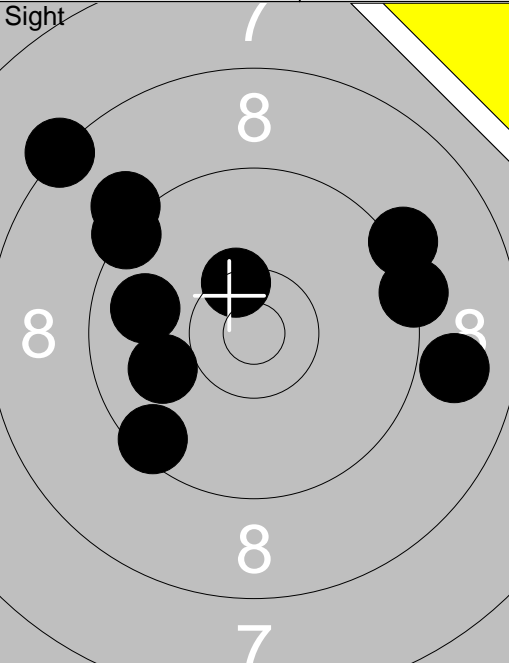
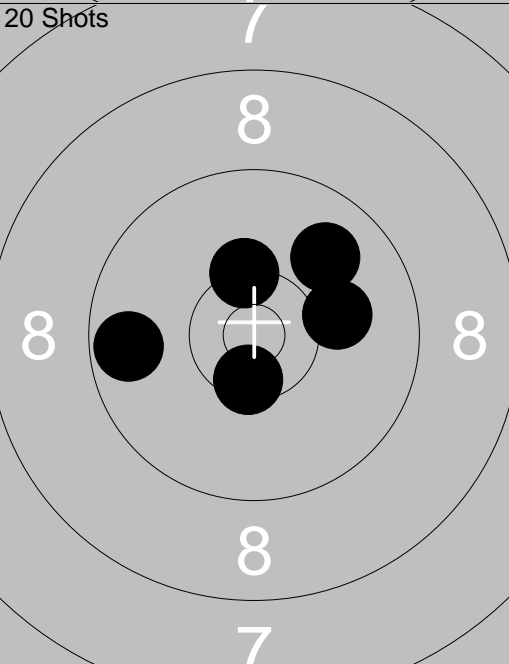
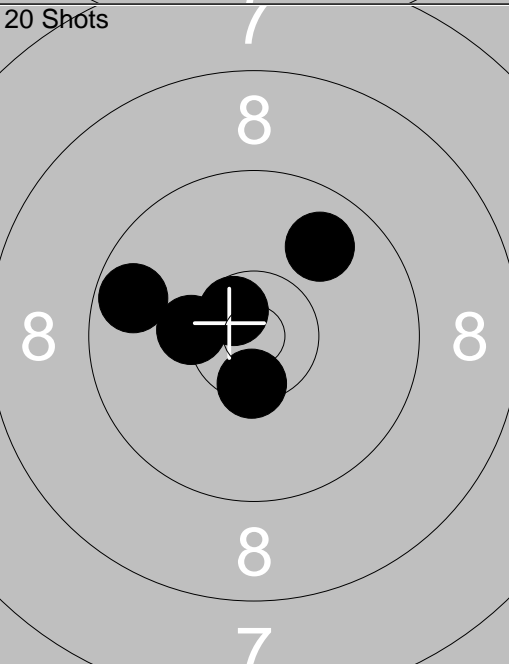

Relay	Lane	Lars Evaldsson	
50m	Göteborg	Vet-L	Vs
2013-07-09	Tavelträffen Korthäll 2013	Ramselefors SKF	
Sight		1: 9.2 ← 2: 9.7 ↙ 3: 10.1 ↗ 4: *10.5 → 5: 9.5 ← 6: *10.3 ↘ 7: 10.0 ← 8: *10.4 ↗ 9: 9.7 ↙ 10: *10.3 ↘ Series 96.0 Total 0.0	Sight
			11: 9.1 → Series 9.0 Total 0.0
20 Shots		1: 10.0 ↓ 2: 10.2 ↓ 3: *10.5 ↘ 4: *10.5 → 5: 10.3 ↙ Series 50.0 Total 50.0	20 Shots
			6: 10.2 ↓ 7: 7.8 ↙ 8: 9.7 ↗ 9: 10.2 → 10: *10.4 ↘ Series 46.0 Total 96.0
20 Shots		11: 9.5 ← 12: *10.5 ↗ 13: 9.6 ↙ 14: 9.9 ↗ 15: 10.0 ↗ Series 47.0 Total 143.0	20 Shots
			16: 10.1 ↗ 17: 10.0 ↗ 18: *10.4 ↓ 19: 10.0 ↘ 20: 10.0 ↗ Series 50.0 Total 193.0

Relay	Lane	Bo Knoblauch			
1	2				
50m	Karlstad-Ulvsby	Vet-L	Vä		
2013-07-09	Tavelträffen Korthäll 2013	Ramselefors SKF			
Sight		1: 8.3 → 2: 7.9 ↗ 3: 8.1 ↑ 4: 8.4 → 5: 8.9 ↖ 6: 9.0 → 7: 9.5 ↗ 8: 9.9 ↑ 9: 10.0 ← 10: 9.7 → Series 85.0 Total 0.0	Sight		11: 9.7 ↖ 12: 9.8 ↖ 13: 9.8 ↖ 14: 9.4 ↑ 15: 9.7 ↗ 16: *10.5 ↘ Series 55.0 Total 0.0
20 Shots		1: 10.2 ↓ 2: 9.9 ↓ 3: 8.8 ↓ 4: 9.3 ↑ 5: 9.7 ↑ Series 45.0 Total 45.0	20 Shots		6: 9.5 → 7: *10.8 ↗ 8: *10.5 → 9: 9.6 ↖ 10: 9.6 ↖ Series 47.0 Total 92.0
20 Shots		11: 9.8 ↗ 12: 8.0 ↖ 13: 10.1 ↖ 14: 9.5 ↑ 15: 9.7 → Series 45.0 Total 137.0	20 Shots		16: 10.2 ↑ 17: 9.1 ↖ 18: *10.4 → 19: 9.9 ↑ 20: *10.8 ↘ Series 48.0 Total 185.0

Relay	Lane	Martin Nilsson	
50m		Kvistbro	Sen-L Ör
2013-07-09		Tavelträffen Korthäll 2013	Ramselefors SKF
Sight		1: 8.3 ↖ 2: *10.4 ↗ 3: 9.5 ↘ 4: 8.9 → 5: 9.3 → 6: 9.2 ↗ 7: 9.1 ↖ 8: 9.3 ↖ 9: 10.0 ↙ 10: 9.8 ←	11: 10.0 ↓ 12: *10.3 ↙ 13: 10.2 ↗ 14: *10.7 ↗
		Series 90.0	Series 40.0
		Total 0.0	Total 0.0
20 Shots		1: 10.1 → 2: *10.3 ↗ 3: 9.9 ↗ 4: 9.7 ← 5: *10.5 ↓	6: *10.4 ↗ 7: *10.5 ↖ 8: *10.3 → 9: 9.8 ↓ 10: 10.2 →
		Series 48.0	Series 49.0
		Total 48.0	Total 97.0
20 Shots		11: *10.3 ↙ 12: 9.8 ↗ 13: 9.7 ← 14: *10.6 ↖ 15: *10.5 ↓	16: 10.0 ↖ 17: 10.3 ↙ 18: 9.7 ↓ 19: *10.4 ↙ 20: 9.6 →
		Series 48.0	Series 48.0
		Total 145.0	Total 193.0

<p style="font-size: 0.8em;">Sight</p>	<p>1: 7.5 ↗</p> <p>2: 9.9 ↖</p> <p>3: *10.4 ←</p> <p>4: 7.8 →</p> <p>5: 9.1 ↗</p> <p>6: 8.7 ↗</p> <p>7: 7.5 ↗</p> <p>8: 9.2 ↗</p> <p>9: 9.3 →</p> <p>10: 7.5 ↘</p>	<p style="font-size: 0.8em;">Sight</p>	<p>11: 9.3 ↗</p>
Series 82.0		Series 9.0	
Total 0.0		Total 0.0	

<p style="font-size: 0.8em;">20 Shots</p>	<p>1: 8.4 ↗</p> <p>2: 9.1 ↘</p> <p>3: 10.1 →</p> <p>4: 9.8 ↓</p> <p>5: 10.2 ↑</p>	<p style="font-size: 0.8em;">20 Shots</p>	<p>6: 9.3 ↖</p> <p>7: 8.3 ↖</p> <p>8: 6.9 ←</p> <p>9: 7.1 ←</p> <p>10: 9.9 ↗</p>
Series 46.0		Series 39.0	
Total 46.0		Total 85.0	

<p style="font-size: 0.8em;">20 Shots</p>	<p>11: 8.5 ↗</p> <p>12: 10.2 →</p> <p>13: 9.0 ↘</p> <p>14: 9.3 ↗</p> <p>15: 8.4 ↗</p>	<p style="font-size: 0.8em;">20 Shots</p>	<p>16: 10.3 →</p> <p>17: 9.7 ↓</p> <p>18: *10.5 ↓</p> <p>19: 9.5 ↖</p> <p>20: 9.9 ↑</p>
Series 44.0		Series 47.0	
Total 129.0		Total 176.0	

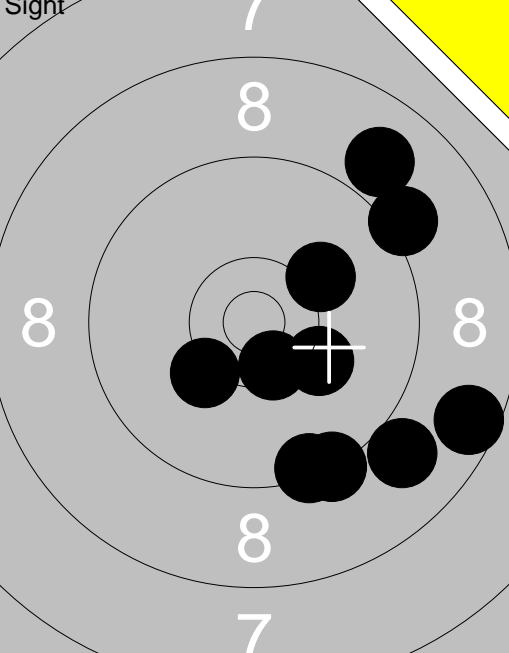
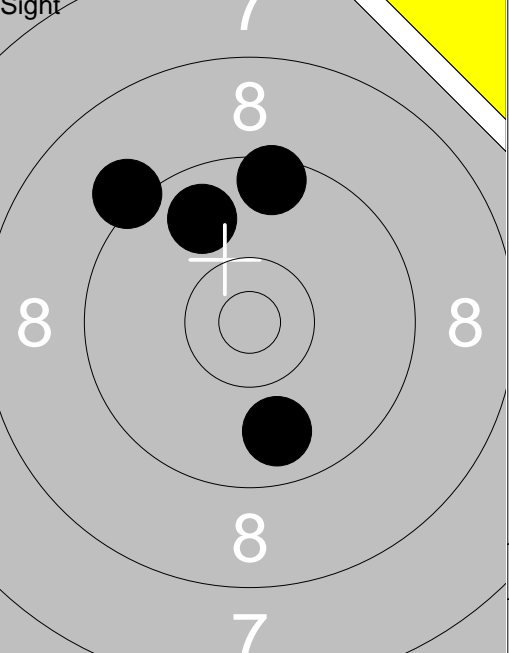
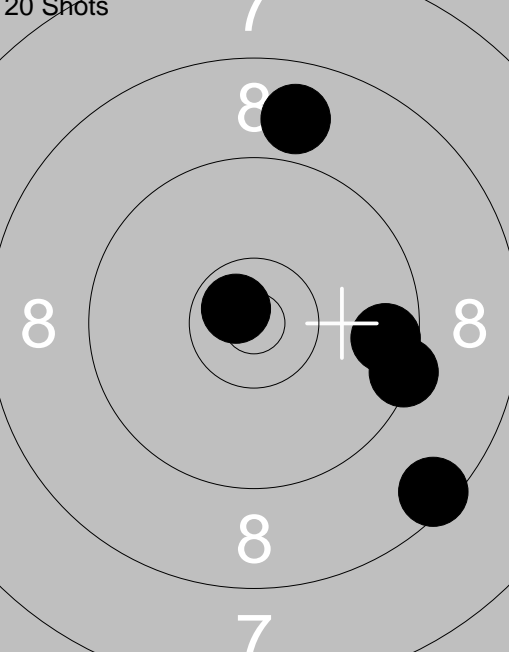
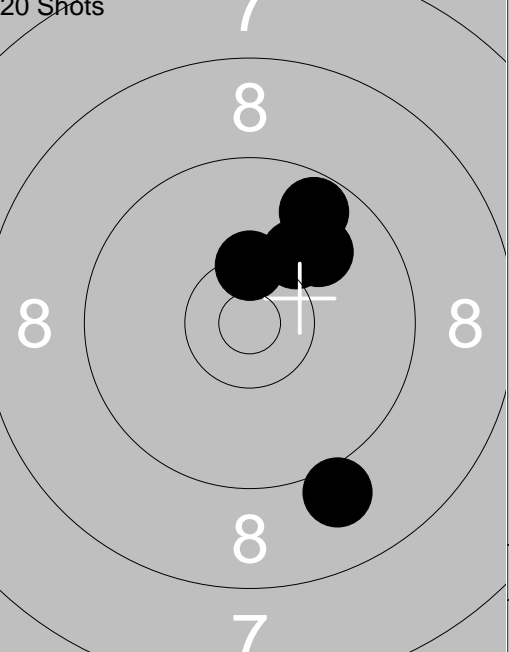
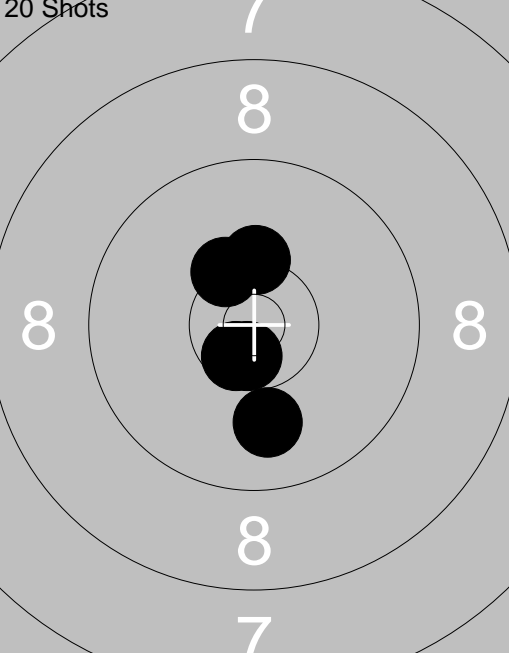
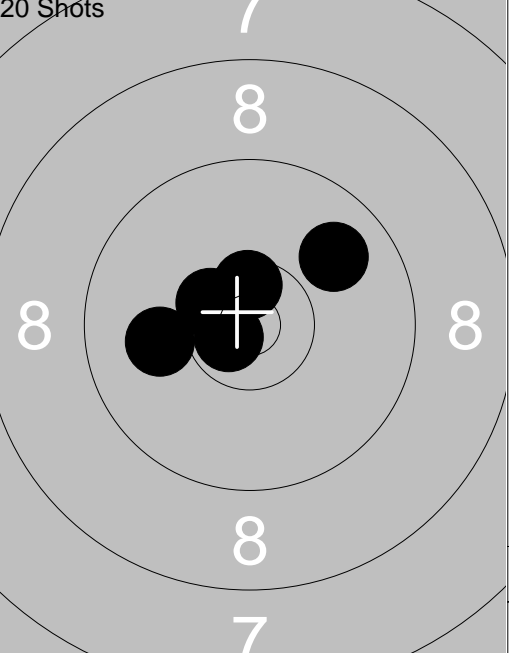
<p>Sight</p> 	<p>1: 9.2 ↗ 2: 10.2 ↘ 3: 10.2 ↘ 4: 9.0 ↘ 5: 9.4 ↘ 6: 8.9 ↗ 7: 8.6 → 8: 10.1 ↗ 9: 9.3 ↘ 10: *10.5 ↘</p> <p>Series 92.0 Total 0.0</p>	<p>Sight</p> 	<p>11: 9.5 ↑ 12: 9.8 ↘ 13: 9.8 ↗ 14: 9.2 ↗</p> <p>Series 36.0 Total 0.0</p>
<p>20 Shots</p> 	<p>1: 9.6 → 2: 8.5 ↘ 3: *10.7 ↗ 4: 9.4 → 5: 8.9 ↑</p> <p>Series 44.0 Total 44.0</p>	<p>20 Shots</p> 	<p>6: 10.1 ↗ 7: 10.0 ↗ 8: *10.4 ↑ 9: 9.0 ↘ 10: 9.7 ↗</p> <p>Series 48.0 Total 92.0</p>
<p>20 Shots</p> 	<p>11: *10.4 ↗ 12: *10.6 ↘ 13: 10.0 ↘ 14: *10.6 ↘ 15: *10.3 ↑</p> <p>Series 50.0 Total 142.0</p>	<p>20 Shots</p> 	<p>16: 9.9 ↗ 17: *10.5 ↗ 18: *10.5 ↑ 19: *10.7 ↗ 20: 10.0 ←</p> <p>Series 49.0 Total 191.0</p>

Relay	Lane	Ida Lundmark	
1	6	Drängsmark	Sen-L Vb
50m		Tavelträffen Korthäll 2013	Ramselefors SKF
2013-07-09			
Sight		1: 10.1 ← 2: 9.8 ↗ 3: 9.6 ↗ 4: 9.9 ↗ 5: 8.5 ↗ 6: 8.6 ↑ 7: 8.8 ↑ 8: 9.9 ↗ 9: 10.2 → 10: 9.9 ↗ Series 89.0 Total 0.0	Sight 11: 9.3 ↓ 12: 6.8 ← 13: 10.1 ↑ 14: 9.4 → Series 34.0 Total 0.0
20 Shots		1: *10.3 ← 2: 10.0 → 3: 9.9 ← 4: 8.5 → 5: *10.6 ↗ Series 47.0 Total 47.0	20 Shots 6: 9.9 → 7: 9.9 ↗ 8: 9.3 → 9: 10.2 → 10: 9.0 ↑ Series 46.0 Total 93.0
20 Shots		11: 10.2 ↑ 12: 9.7 → 13: 10.1 → 14: 9.4 → 15: *10.5 ← Series 48.0 Total 141.0	20 Shots 16: 9.5 → 17: 9.7 ↗ 18: 9.0 ↑ 19: 8.7 ↗ 20: 9.2 → Series 44.0 Total 185.0

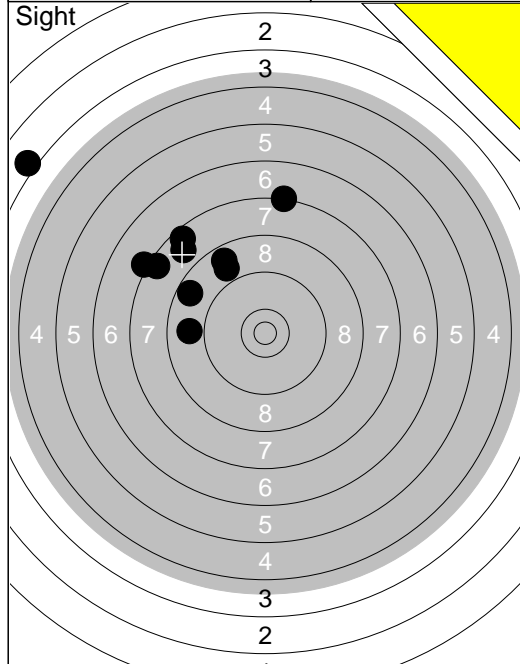

1:	3.1	↖
2:	7.8	↗
3:	7.2	↖
4:	7.5	↖
5:	8.9	←
6:	7.6	↗
7:	7.3	↑
8:	8.7	↗
9:	8.9	↗
10:	8.7	↖
Series		70.0
Total		0.0

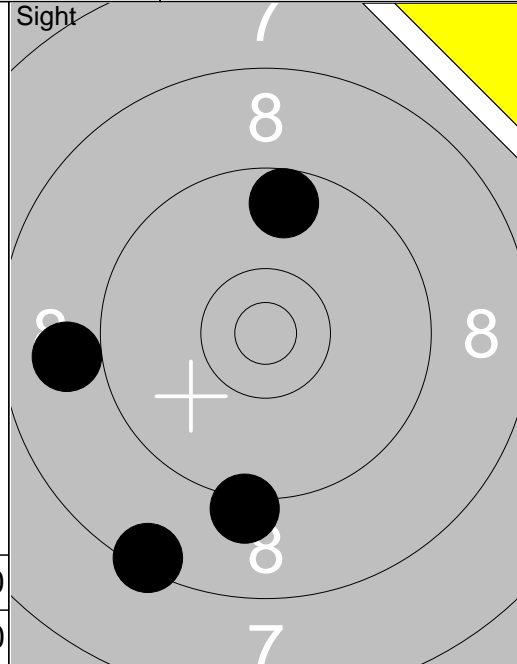

11:	8.9	←
12:	9.6	↑
13:	8.4	↘
14:	9.2	↘
Series		34.0
Total		0.0

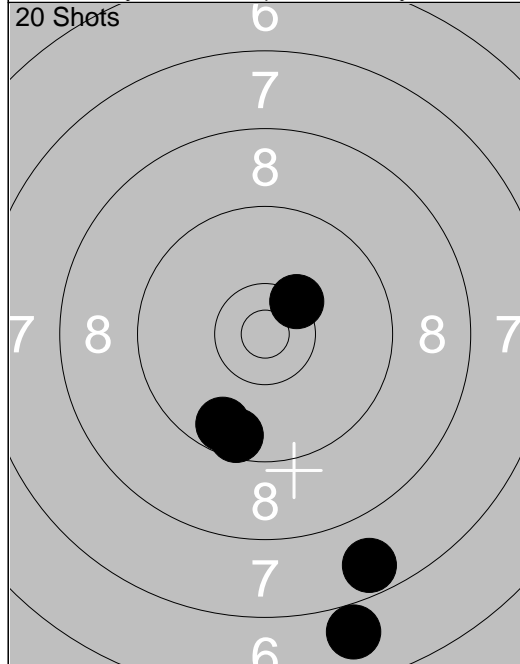

1:	6.9	↘
2:	7.7	↘
3:	*10.4	↗
4:	9.7	↘
5:	9.6	↘
Series		41.0
Total		41.0

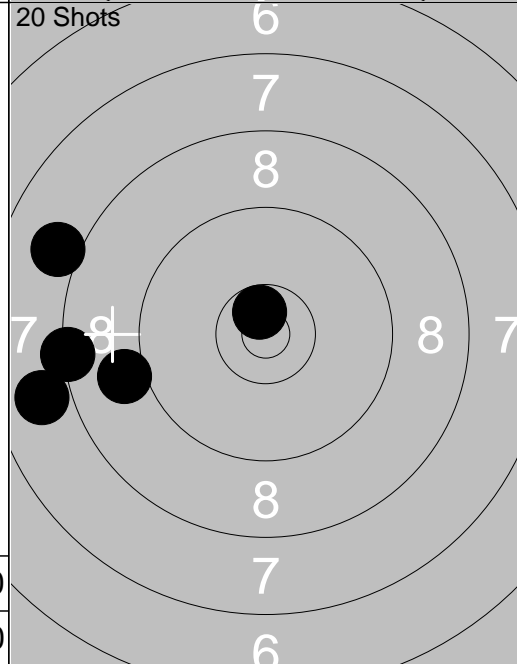

6:	7.9	←
7:	*10.7	↗
8:	8.4	←
9:	9.0	←
10:	8.0	↖
Series		42.0
Total		83.0

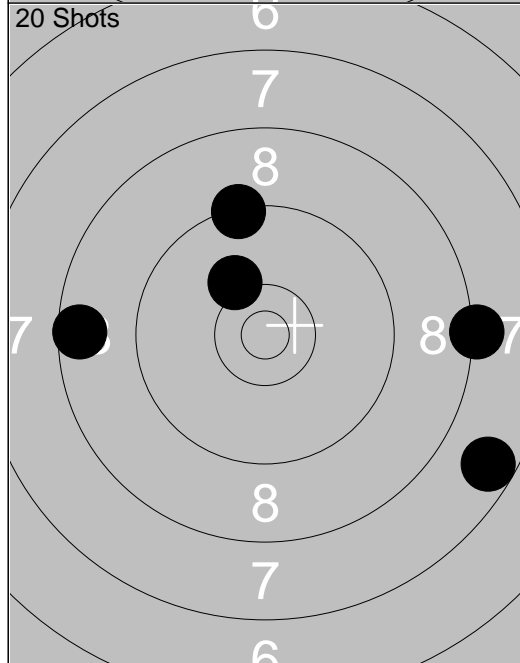

11:	8.6	←
12:	8.2	→
13:	7.7	↘
14:	10.2	↗
15:	9.3	↑
Series		42.0
Total		125.0

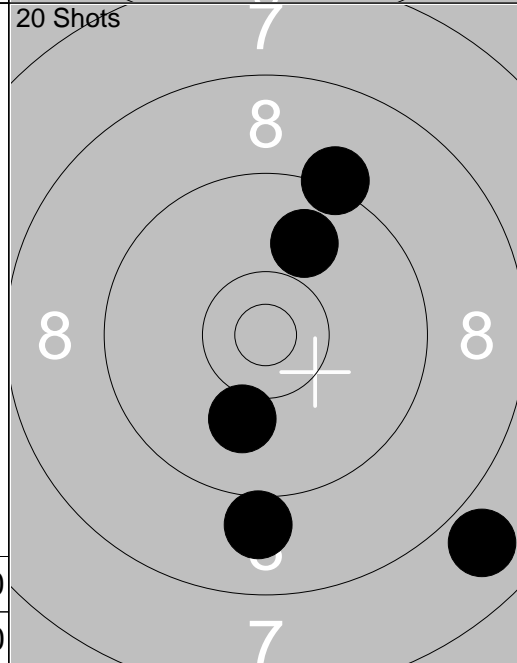

16:	9.2	↗
17:	9.9	↗
18:	9.0	↘
19:	7.9	↘
20:	10.1	↘
Series		44.0
Total		169.0

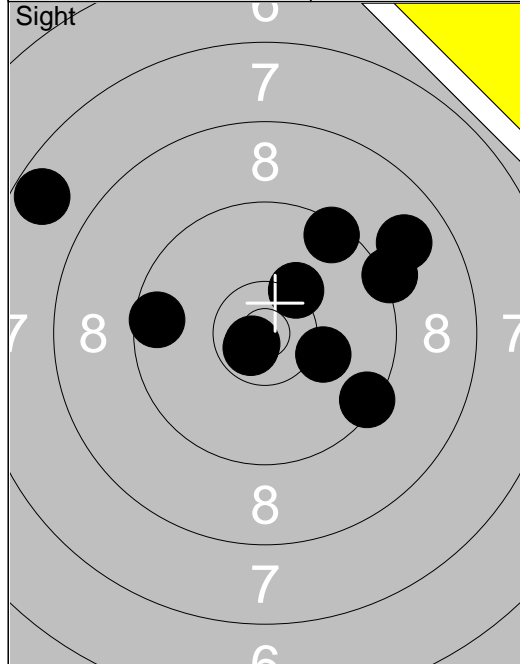

1:	7.7	↖
2:	9.6	←
3:	9.4	→
4:	*10.7	↙
5:	8.9	↗
6:	*10.7	↙
7:	9.2	→
8:	9.5	↗
9:	10.3	↗
10:	10.2	→
Series	91.0	
Total	0.0	

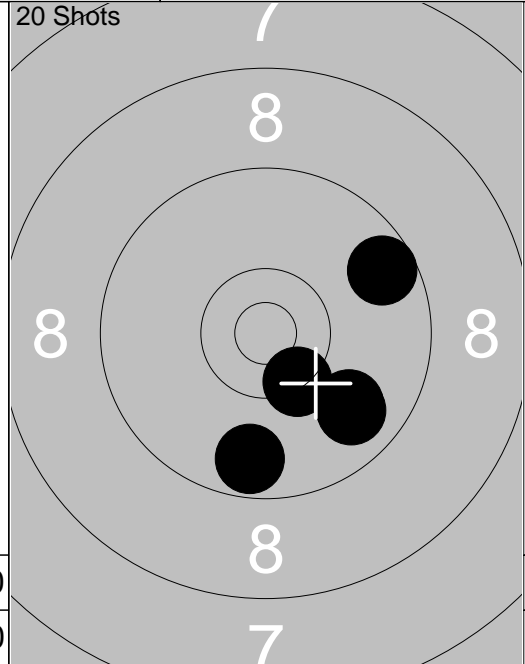

1:	*10.4	↘
2:	9.6	↗
3:	9.8	↘
4:	9.7	↓
5:	9.9	↘
Series	46.0	
Total	46.0	

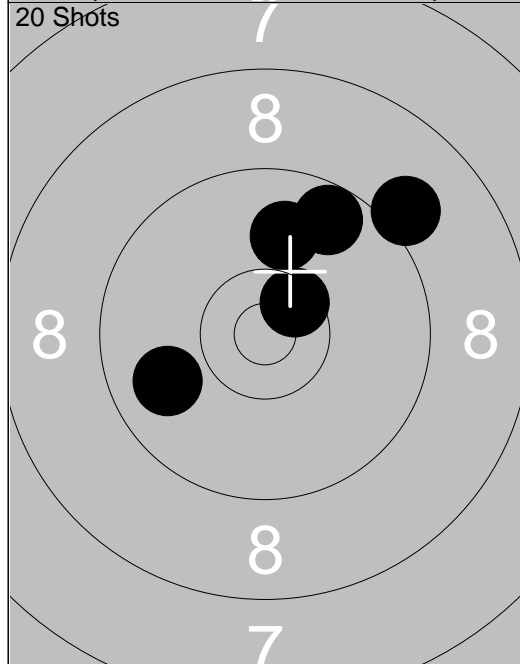

6:	*10.5	↗
7:	9.7	↗
8:	9.1	↗
9:	9.9	↑
10:	9.9	←
Series	46.0	
Total	92.0	

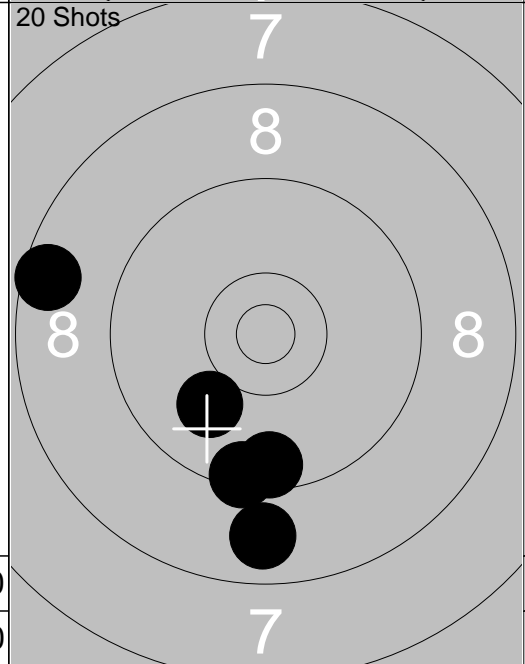

11:	8.8	↓
12:	10.0	↙
13:	8.6	←
14:	9.6	↓
15:	9.4	↓
Series	44.0	
Total	136.0	

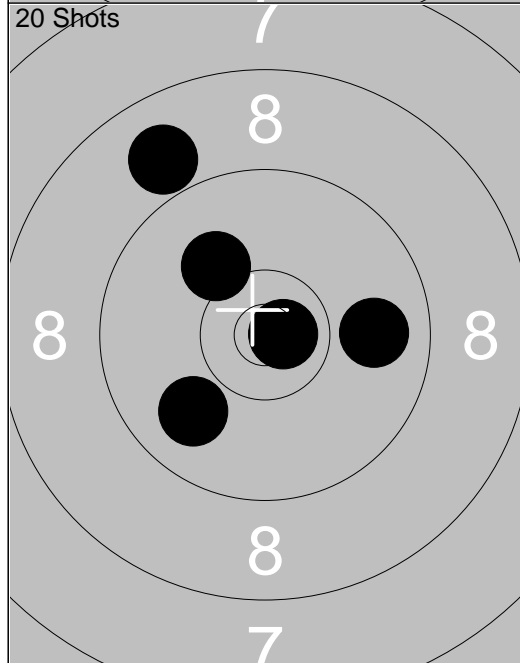

16:	9.9	↙
17:	9.9	→
18:	*10.8	→
19:	8.9	↗
20:	10.1	↖
Series	46.0	
Total	182.0	

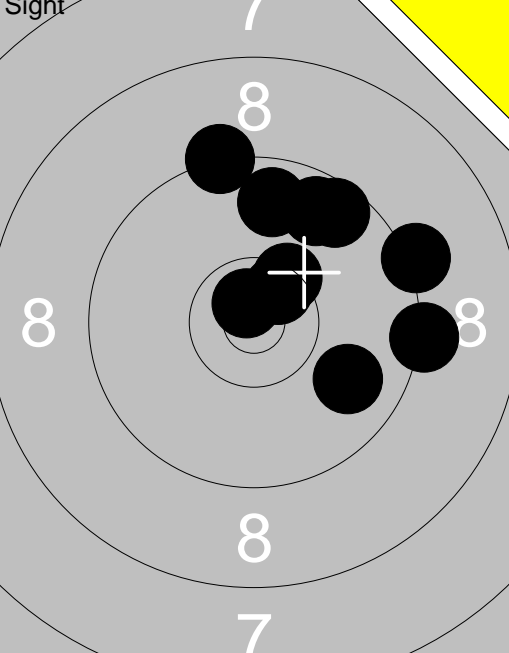
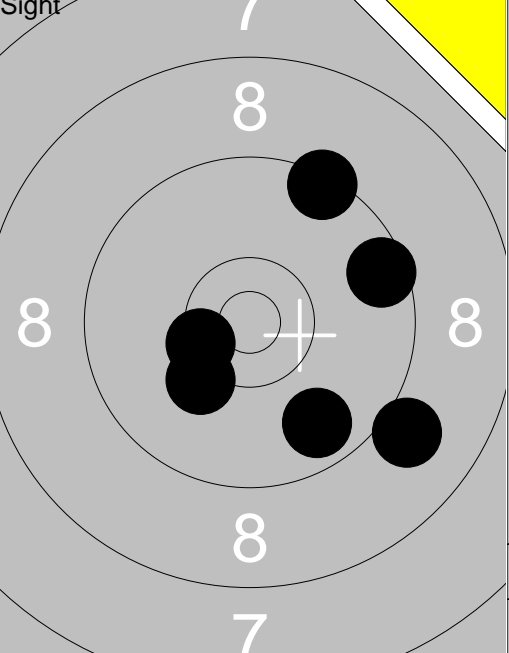
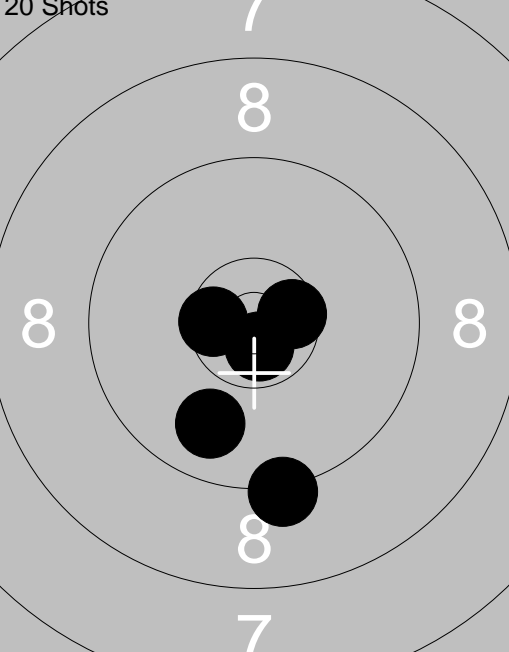
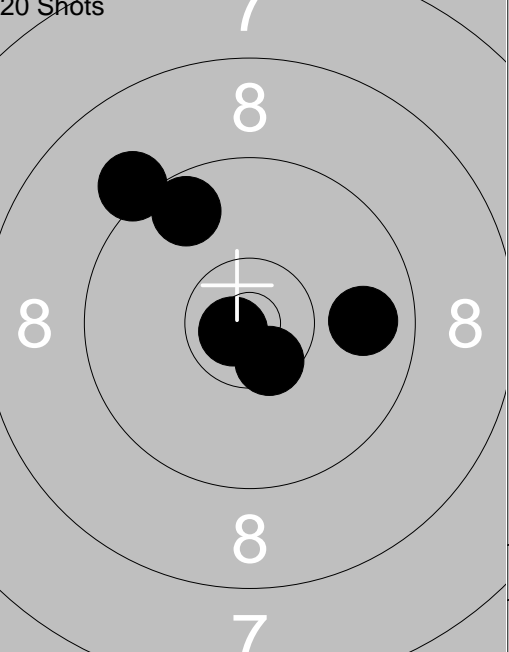
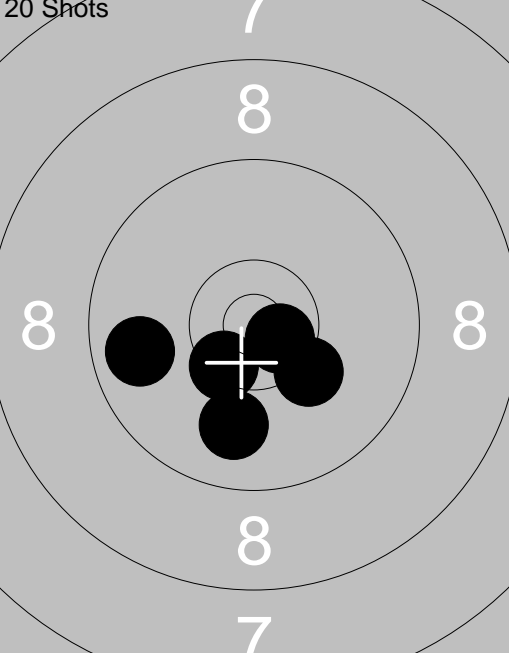
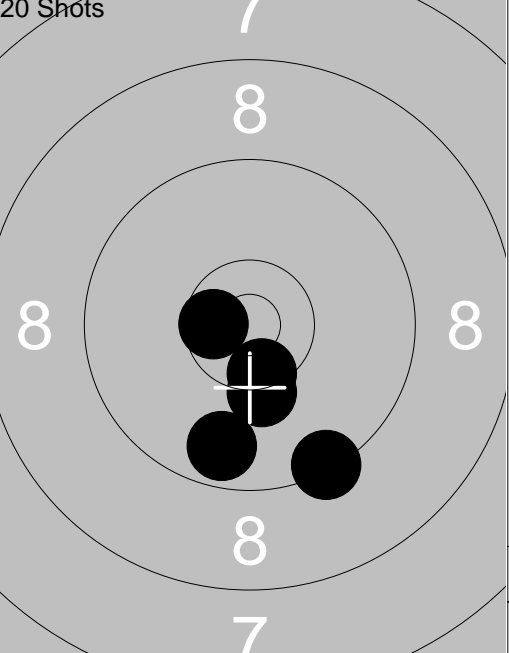
<p>Sight</p> 	<p>1: 9.7 ↑ 2: 9.3 ↑ 3: *10.4 ↗ 4: 9.7 ↑ 5: 9.2 → 6: 9.6 ↗ 7: 9.2 → 8: *10.7 ↗ 9: 9.9 → 10: *10.5 ↗</p> <p>Series 93.0 Total 0.0</p>	<p>Sight</p> 	<p>11: 9.4 ↗ 12: 9.0 → 13: 10.2 ↘ 14: 9.5 → 15: 9.7 ↘ 16: *10.4 ↘</p> <p>Series 56.0 Total 0.0</p>
<p>20 Shots</p> 	<p>1: 9.9 ↘ 2: 9.2 ↘ 3: *10.7 ↘ 4: *10.6 → 5: *10.5 ←</p> <p>Series 48.0 Total 48.0</p>	<p>20 Shots</p> 	<p>6: 9.8 → 7: 9.2 ↗ 8: *10.8 ↘ 9: 9.7 ↗ 10: *10.5 ↘</p> <p>Series 47.0 Total 95.0</p>
<p>20 Shots</p> 	<p>11: *10.4 ↘ 12: 9.8 ← 13: 10.2 ↘ 14: *10.7 → 15: 9.9 ↘</p> <p>Series 48.0 Total 143.0</p>	<p>20 Shots</p> 	<p>16: 9.4 ↘ 17: *10.6 ← 18: 10.3 ↘ 19: 9.7 ↘ 20: *10.4 ↘</p> <p>Series 48.0 Total 191.0</p>

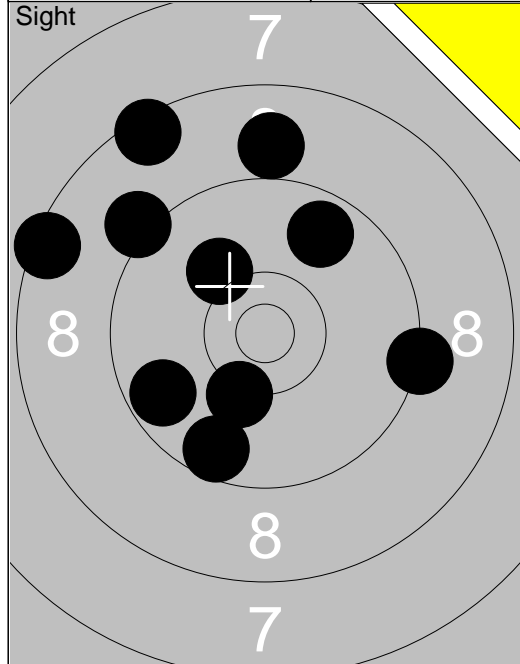

1:	8.5	↖
2:	9.2	↖
3:	10.2	↙
4:	9.3	→
5:	9.6	↙
6:	8.5	↖
7:	9.7	↖
8:	9.0	↑
9:	10.1	↖
10:	9.7	↗
Series	90.0	
Total	0.0	

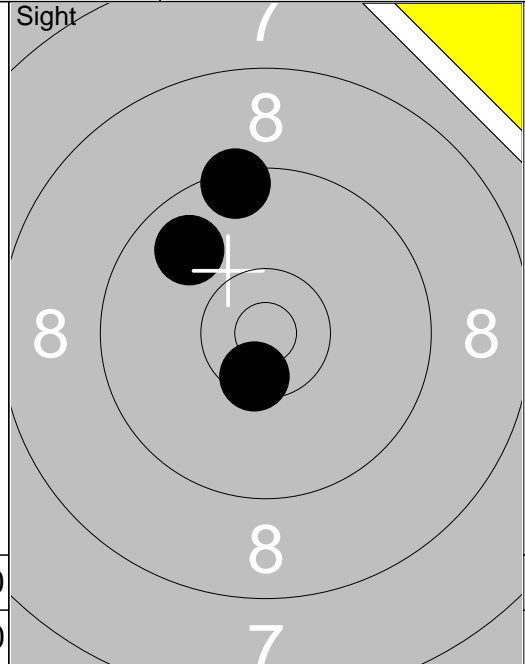

11:	9.4	↑
12:	9.8	↖
13:	*10.5	↙
Series	28.0	
Total	0.0	

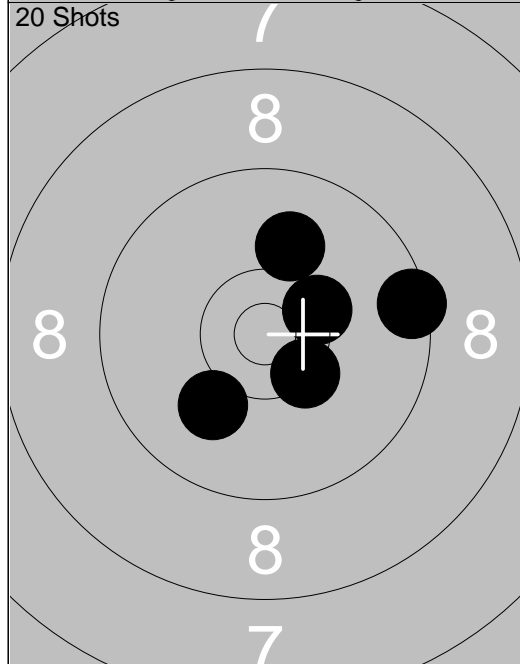

1:	10.1	↙
2:	*10.4	↘
3:	*10.4	↗
4:	9.5	→
5:	10.0	↑
Series	49.0	
Total	49.0	

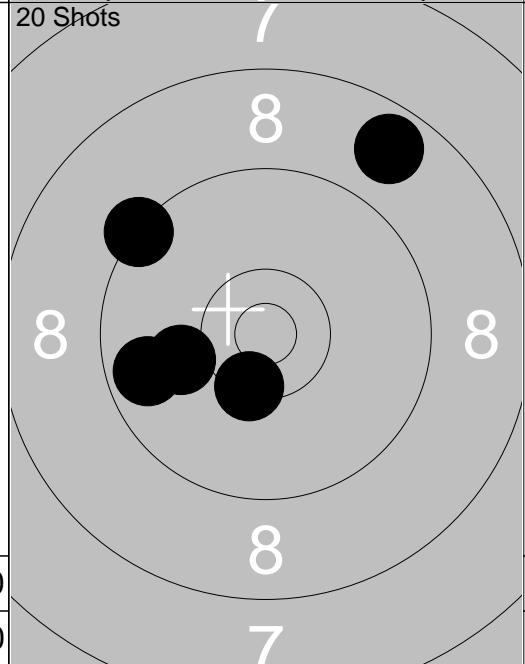

6:	9.3	↖
7:	10.1	↖
8:	*10.4	↙
9:	9.7	↖
10:	8.7	↗
Series	46.0	
Total	95.0	

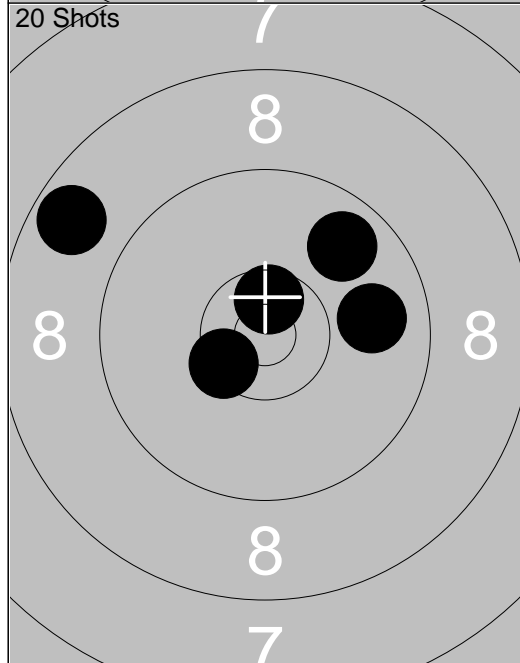

11:	8.7	↖
12:	*10.6	↑
13:	9.9	→
14:	9.8	↗
15:	*10.4	↙
Series	46.0	
Total	141.0	

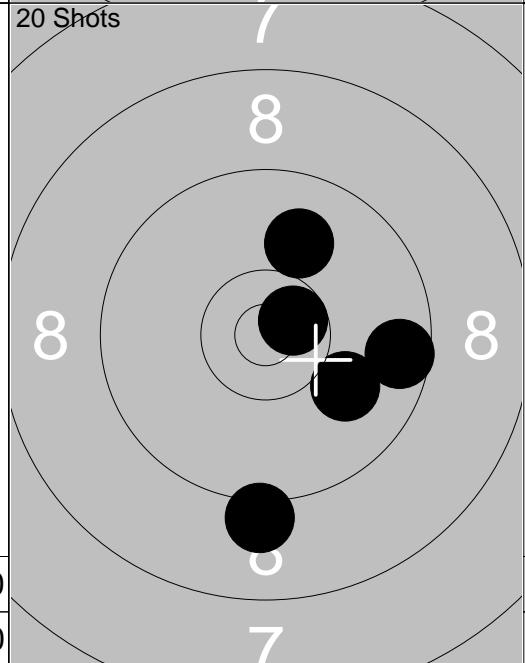

16:	9.1	↓
17:	*10.6	↗
18:	10.0	↘
19:	10.0	↑
20:	9.6	→
Series	48.0	
Total	189.0	

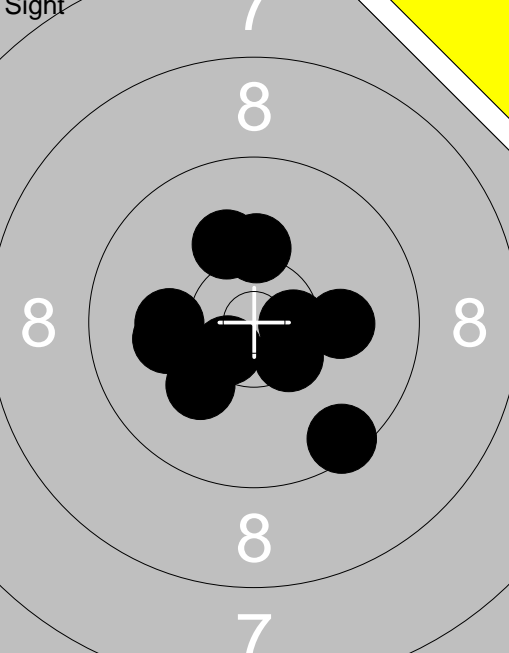
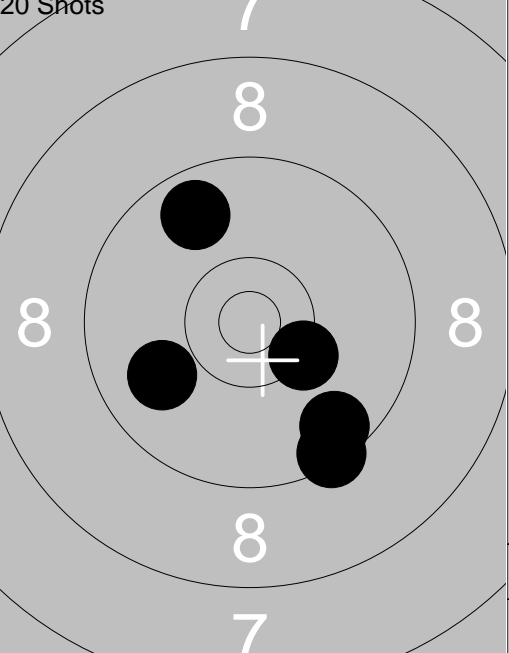
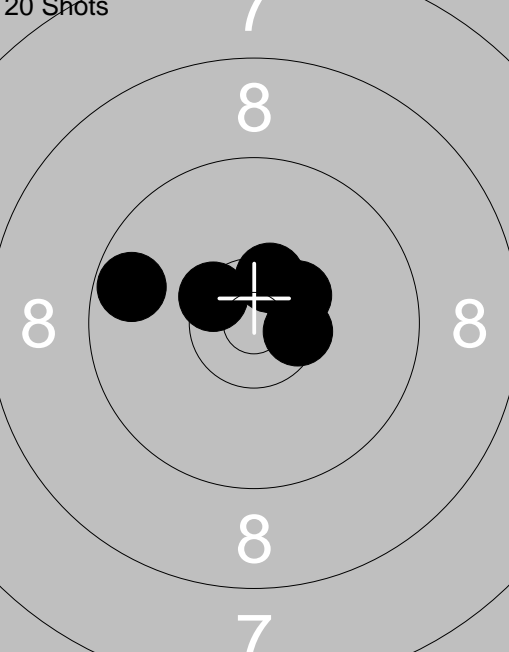
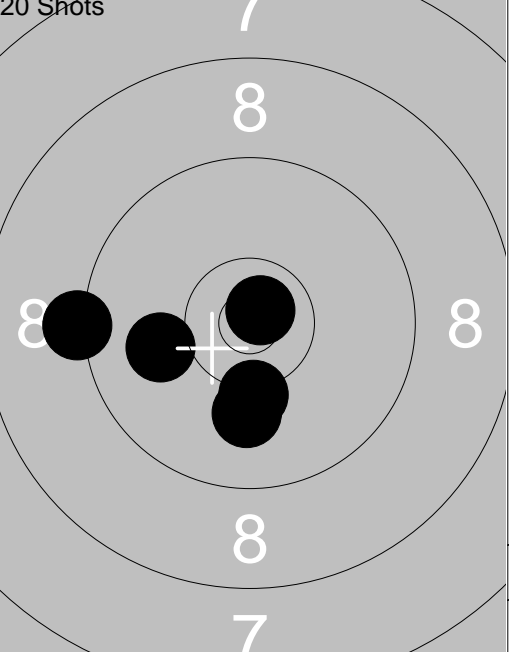
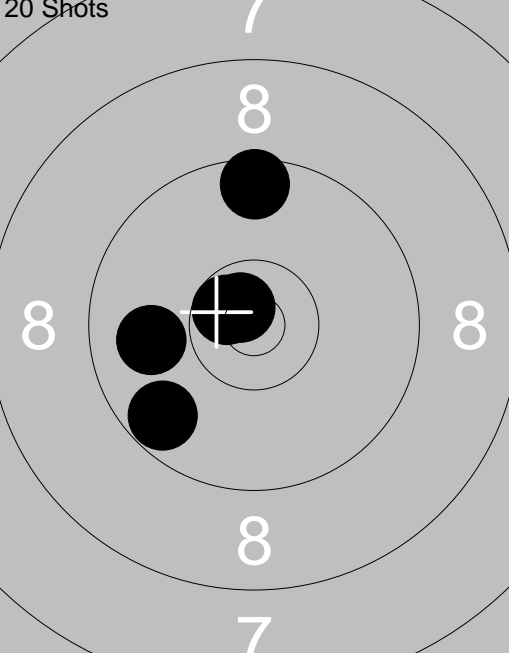
<p>Sight</p> 	<p>1: *10.5 ↘</p> <p>2: 10.2 ↑</p> <p>3: 10.1 ↑</p> <p>4: 9.5 ↘</p> <p>5: 10.1 ←</p> <p>6: *10.6 ↘</p> <p>7: *10.6 →</p> <p>8: 10.1 →</p> <p>9: 10.1 ↘</p> <p>10: 10.1 ←</p>	<p>20 Shots</p> 		<p>1: 9.4 ↘</p> <p>2: 9.6 ↘</p> <p>3: 9.7 ↑</p> <p>4: *10.3 ↘</p> <p>5: 9.9 ↙</p>
Series 99.0		Series 46.0		
Total 0.0		Total 46.0		
<p>20 Shots</p> 	<p>6: *10.5 ↑</p> <p>7: *10.4 ↗</p> <p>8: *10.5 →</p> <p>9: 9.7 ←</p> <p>10: *10.5 ↘</p>	<p>20 Shots</p> 		<p>11: *10.8 ↗</p> <p>12: 9.2 ←</p> <p>13: 10.1 ↓</p> <p>14: 10.0 ←</p> <p>15: 10.2 ↓</p>
Series 49.0		Series 49.0		
Total 95.0		Total 144.0		
<p>20 Shots</p> 	<p>16: 9.5 ↑</p> <p>17: *10.6 ↘</p> <p>18: 9.7 ↘</p> <p>19: *10.7 ↗</p> <p>20: 9.9 ←</p>			
Series 47.0				
Total 191.0				

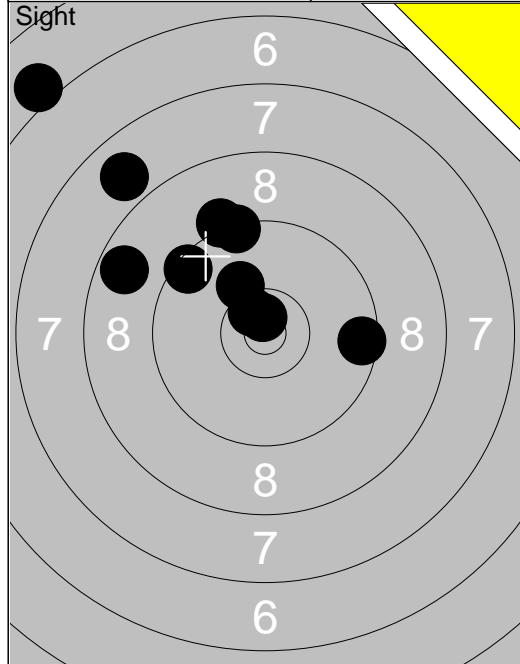

1: 6.1 ↗
2: 7.9 ↗
3: 9.2 ↗
4: 8.7 ↖
5: *10.6 ↘
6: 10.2 ↗
7: 9.4 ↗
8: *10.7 ↗
9: 9.5 ↖
10: 9.5 →
Series 87.0
Total 0.0

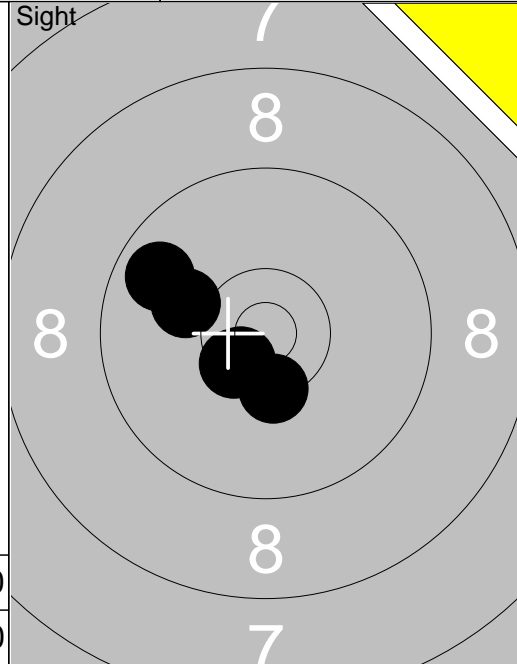

11: *10.4 ↘
12: *10.6 ↘
13: 10.1 ↖
14: *10.5 ↘
15: 9.8 ↖
Series 49.0
Total 0.0

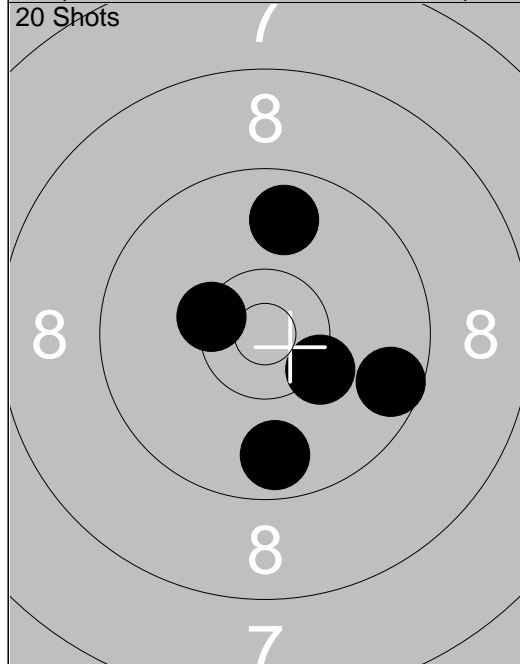

1: 9.6 →
2: 9.8 ↑
3: *10.4 ↖
4: *10.3 ↘
5: 9.7 ↓
Series 47.0
Total 47.0

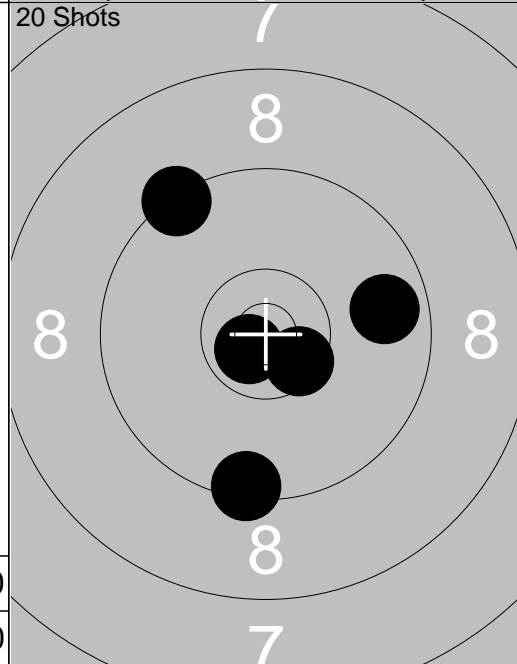

6: 9.7 →
7: *10.5 ↘
8: 9.4 ↓
9: 9.3 ↖
10: *10.7 ↘
Series 47.0
Total 94.0

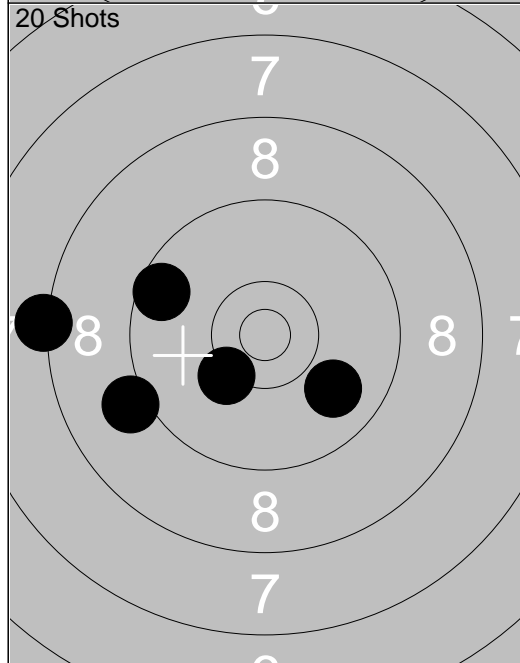

11: 9.9 ↘
12: 10.3 ↘
13: 9.6 ↖
14: 9.1 ↖
15: 8.2 ↖
Series 45.0
Total 139.0

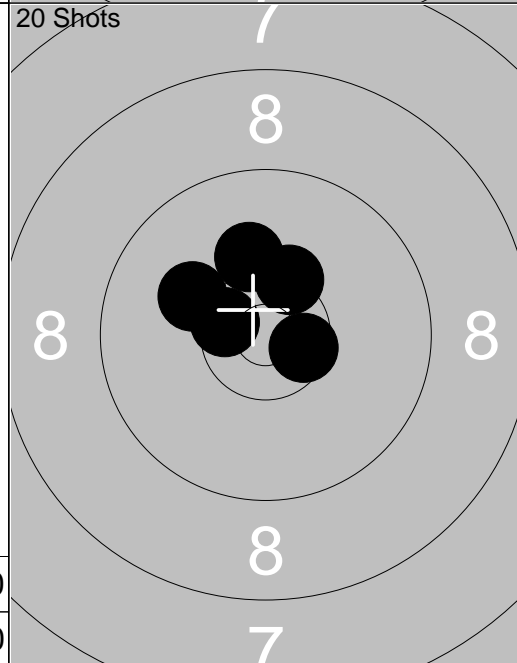

16: *10.5 ↖
17: 10.2 ↑
18: 10.1 ↖
19: *10.4 ↗
20: *10.5 →
Series 50.0
Total 189.0

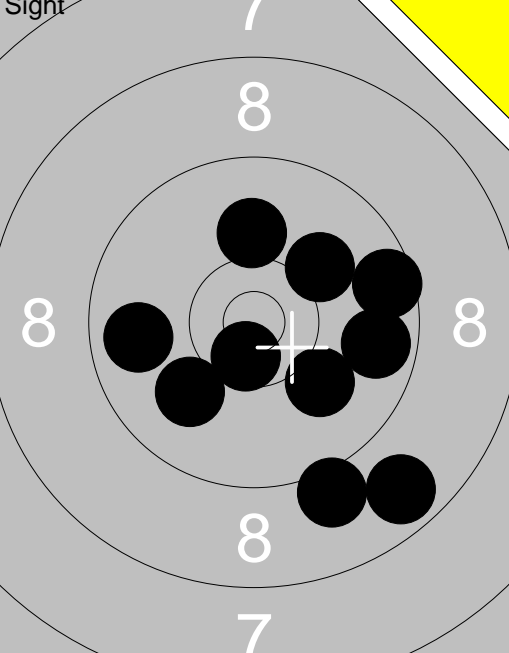
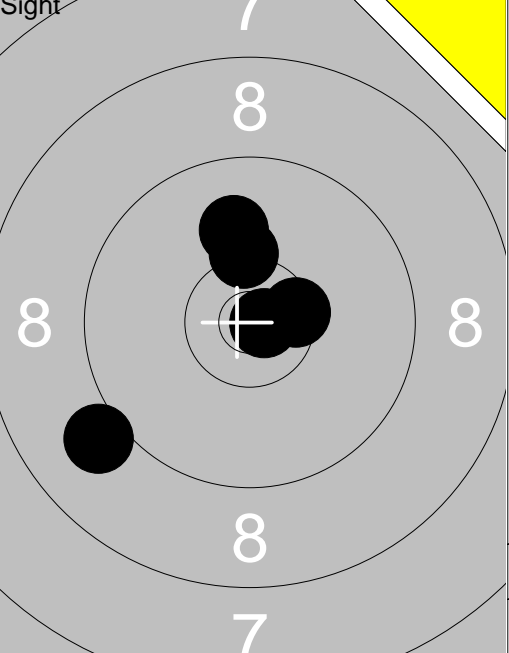
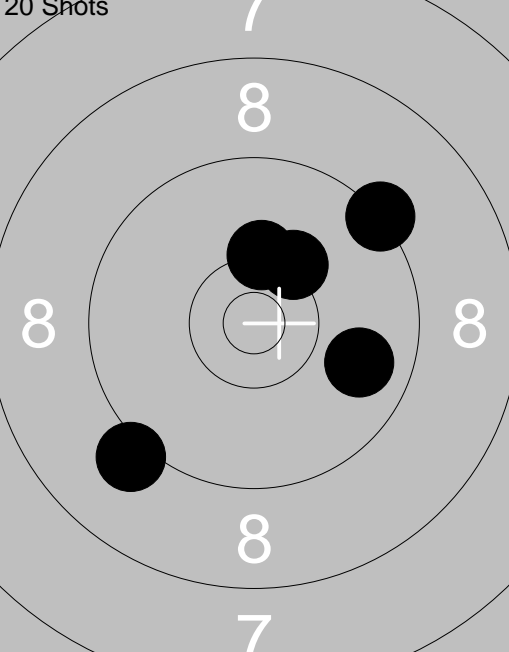
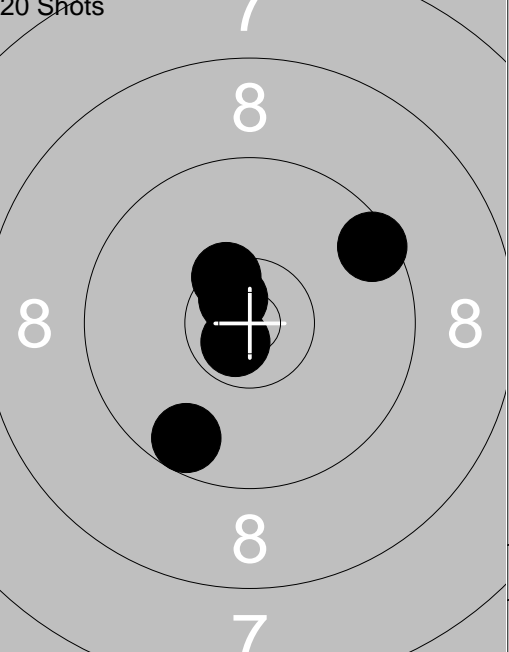
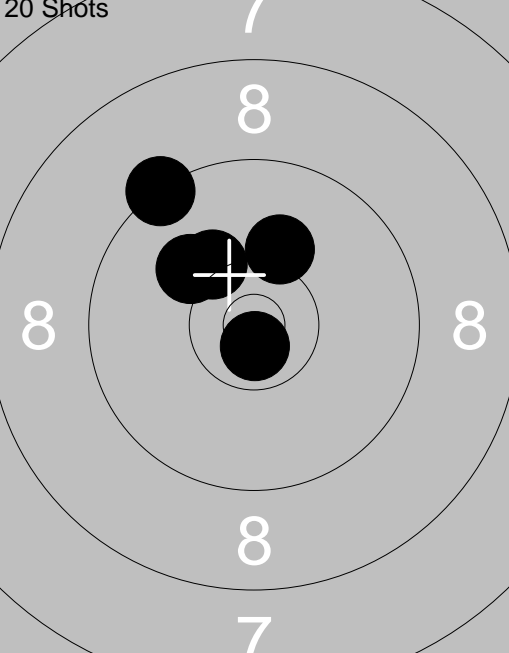
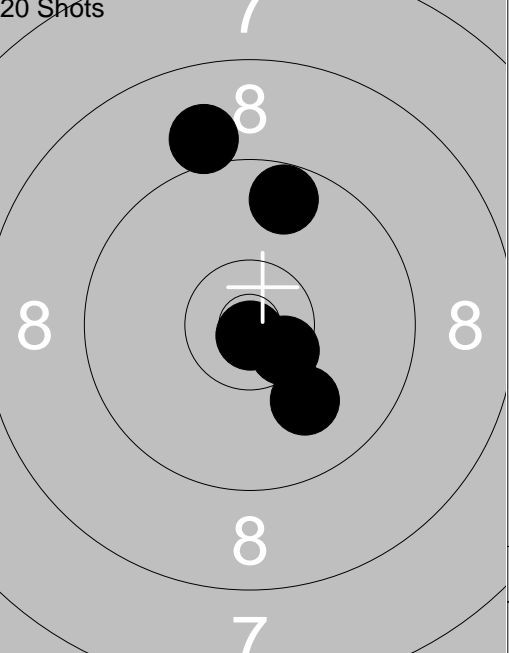
Sight	Series	Total	Sight	Series	Total
 <p>1: 8.7 ↘ 2: 10.1 ↗ 3: 9.6 → 4: 9.7 → 5: 9.1 ↓ 6: *10.6 ↓ 7: 9.8 ← 8: 10.1 ↓ 9: 10.1 ↑ 10: 10.0 ↙</p>	94.0	0.0	 <p>11: 9.1 ↙ 12: 10.3 ↑ 13: 10.0 ↑ 14: *10.5 → 15: *10.8 →</p>	49.0	0.0
 <p>1: 9.1 ↙ 2: 9.3 ↗ 3: 10.3 ↑ 4: 9.8 → 5: 10.3 ↗</p>	47.0	47.0	 <p>6: *10.7 ↖ 7: 9.6 ↓ 8: *10.7 ↓ 9: 9.5 ↗ 10: *10.4 ↖</p>	48.0	95.0
 <p>11: *10.7 ↓ 12: 10.2 ↖ 13: 10.1 ↖ 14: 9.3 ↖ 15: 10.2 ↑</p>	49.0	144.0	 <p>16: *10.8 ↓ 17: 9.0 ↑ 18: *10.5 ↘ 19: 10.0 ↓ 20: 9.7 ↑</p>	48.0	192.0

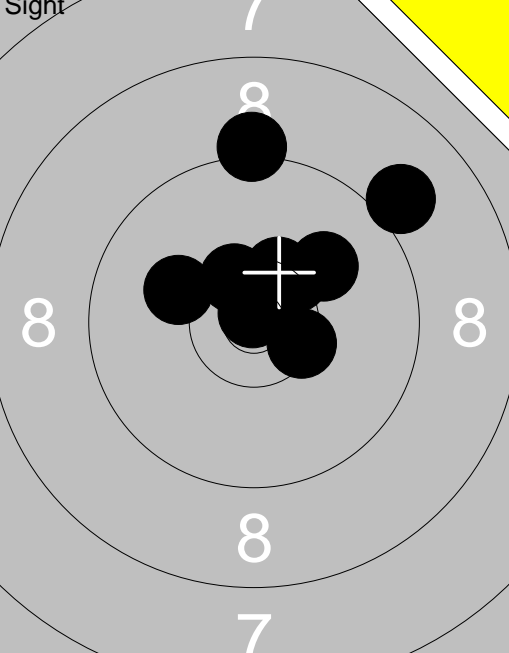
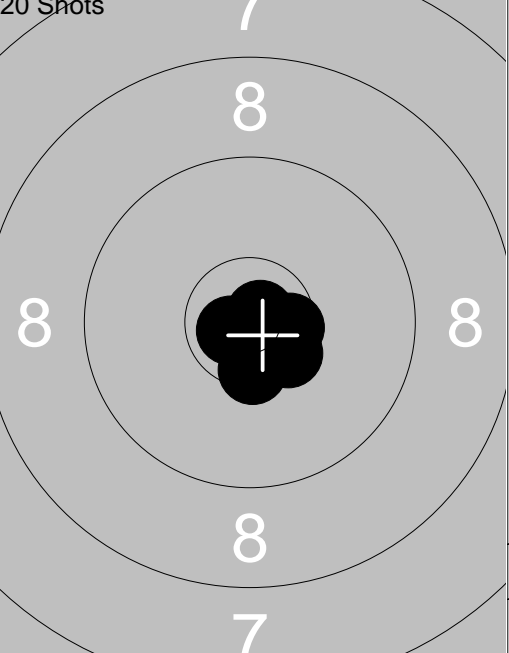
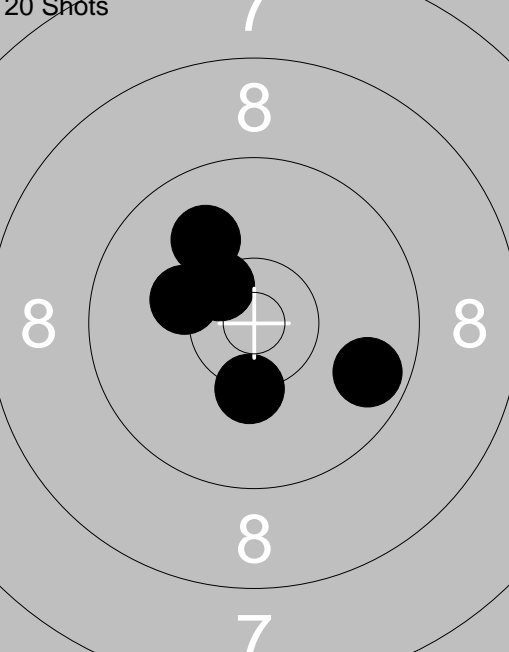
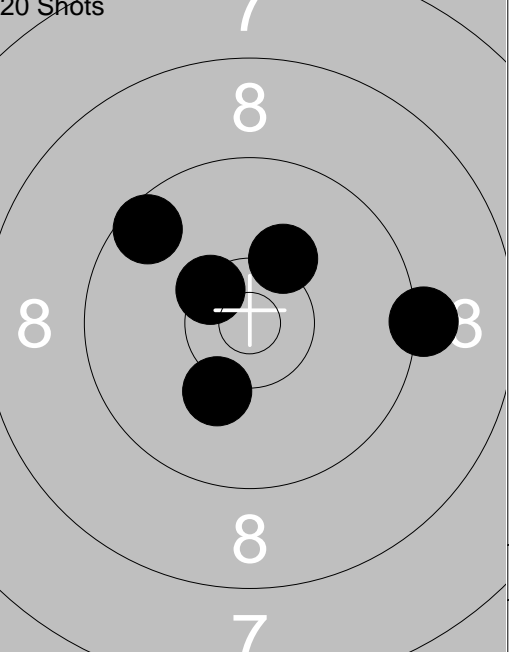
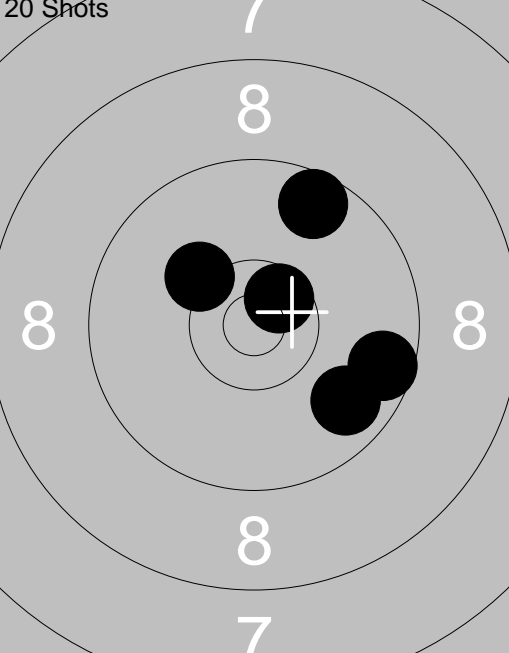
<p style="font-size: small;">Sight</p>  <p style="text-align: center; font-size: 2em; font-weight: bold;">8</p> <p style="text-align: center; font-size: 2em; font-weight: bold;">7</p>	<p>1: *10.4 ➤</p> <p>2: *10.9 ↑</p> <p>3: *10.4 ↗</p> <p>4: 9.0 ↗</p> <p>5: *10.3 ↗</p> <p>6: 9.2 ↑</p> <p>7: 10.1 ↗</p> <p>8: *10.5 ↖</p> <p>9: 10.1 ↖</p>	<p style="font-size: small;">20 Shots</p>  <p style="text-align: center; font-size: 2em; font-weight: bold;">8</p> <p style="text-align: center; font-size: 2em; font-weight: bold;">7</p>		<p>1: *10.7 ↖</p> <p>2: *10.5 ➤</p> <p>3: *10.5 ↘</p> <p>4: *10.5 ↓</p> <p>5: *10.8 ↗</p>
	Series 88.0			Series 50.0
	Total 0.0			Total 50.0
<p style="font-size: small;">20 Shots</p>  <p style="text-align: center; font-size: 2em; font-weight: bold;">8</p> <p style="text-align: center; font-size: 2em; font-weight: bold;">7</p>	<p>6: 10.0 ↖</p> <p>7: *10.4 ↖</p> <p>8: 10.2 ↖</p> <p>9: *10.3 ↓</p> <p>10: 9.7 ➤</p>	<p style="font-size: small;">20 Shots</p>  <p style="text-align: center; font-size: 2em; font-weight: bold;">8</p> <p style="text-align: center; font-size: 2em; font-weight: bold;">7</p>		<p>11: 10.2 ↓</p> <p>12: *10.4 ↖</p> <p>13: 10.2 ↗</p> <p>14: 9.6 ↖</p> <p>15: 9.2 ➤</p>
	Series 49.0			Series 48.0
	Total 99.0			Total 147.0
<p style="font-size: small;">20 Shots</p>  <p style="text-align: center; font-size: 2em; font-weight: bold;">8</p> <p style="text-align: center; font-size: 2em; font-weight: bold;">7</p>	<p>16: 10.2 ↖</p> <p>17: 9.8 ➤</p> <p>18: 9.6 ↗</p> <p>19: *10.6 ↗</p> <p>20: 9.6 ➤</p>			
	Series 47.0			
	Total 194.0			

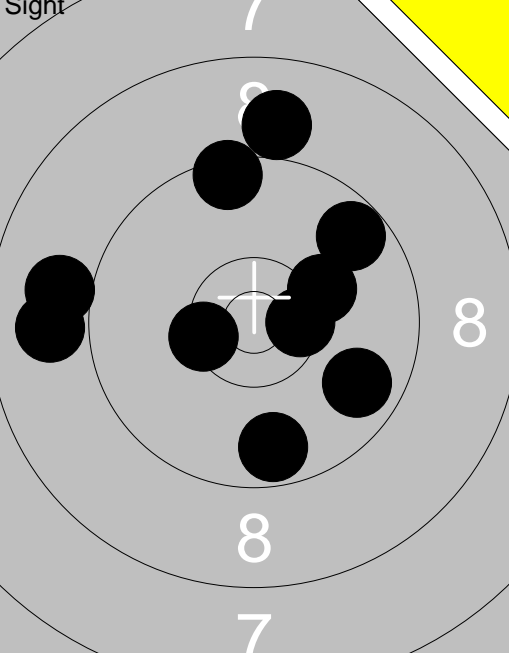
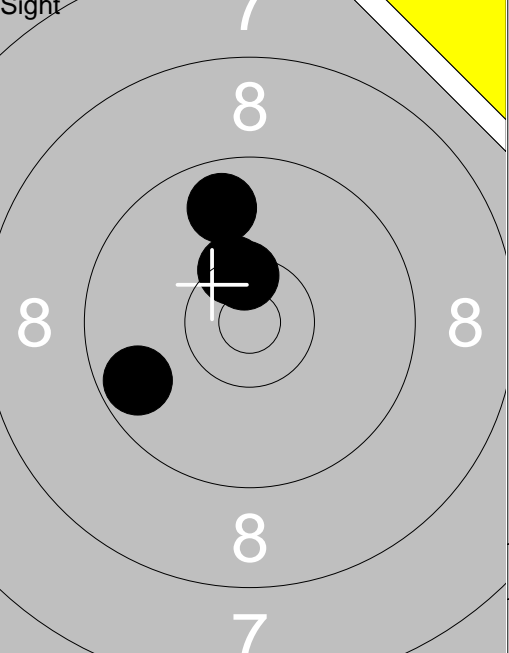
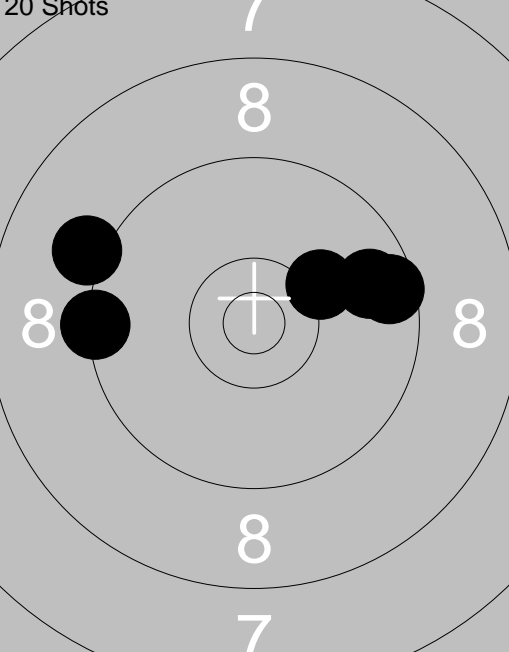
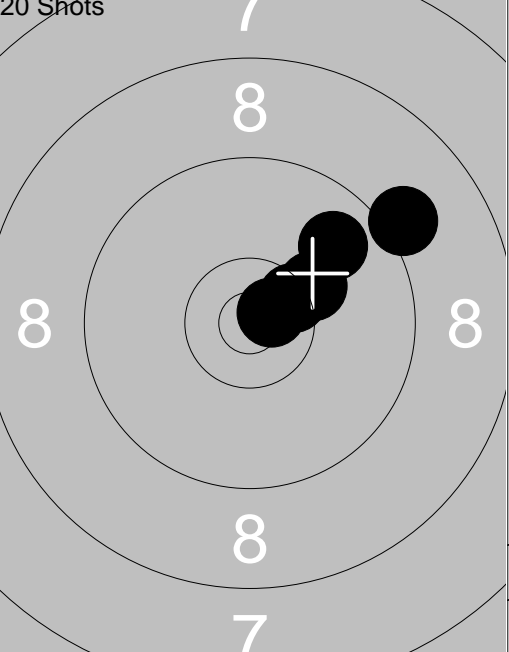
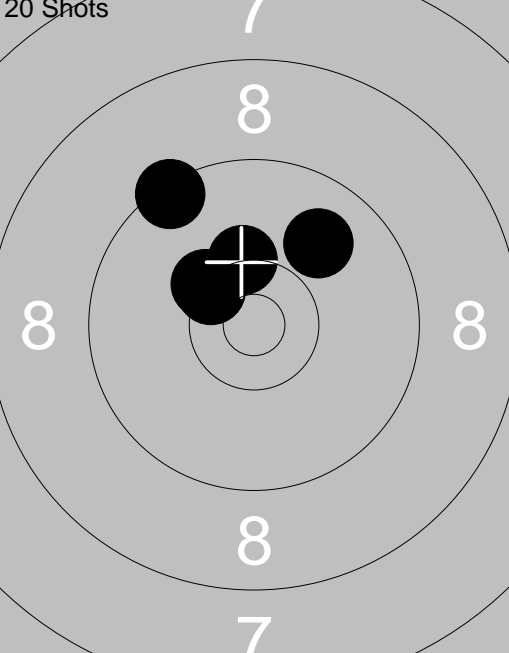
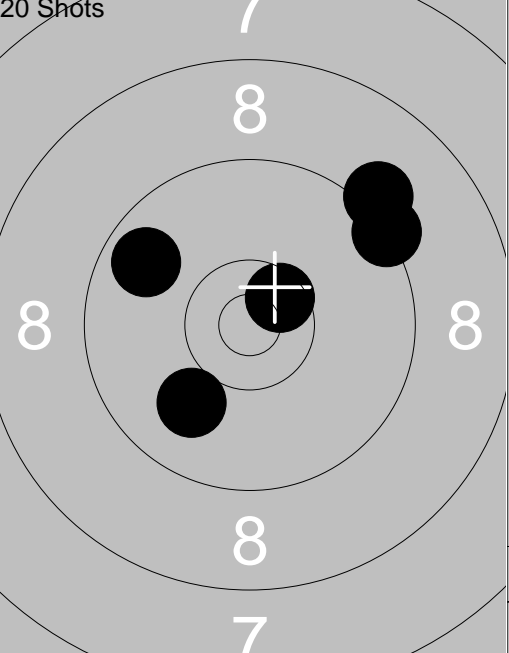
<p>Sight</p>  <p style="text-align: center;">8</p>	<p>1: 9.7 ↓</p> <p>2: 9.0 ↑</p> <p>3: 8.9 ←</p> <p>4: *10.5 →</p> <p>5: 10.2 →</p> <p>6: 9.5 ↑</p> <p>7: 9.8 →</p> <p>8: 9.0 ←</p> <p>9: 9.7 ↗</p> <p>10: *10.4 ↙</p> <hr/> <p>Series 92.0</p> <p>Total 0.0</p>	<p>Sight</p>  <p style="text-align: center;">8</p>	<p>11: 9.7 ↙</p> <p>12: *10.5 ↑</p> <p>13: 9.8 ↑</p> <p>14: *10.4 ↗</p> <hr/> <p>Series 38.0</p> <p>Total 0.0</p>
<p>20 Shots</p>  <p style="text-align: center;">8</p>	<p>1: 9.7 →</p> <p>2: 9.1 ←</p> <p>3: 9.6 →</p> <p>4: 10.2 →</p> <p>5: 9.4 ←</p> <hr/> <p>Series 46.0</p> <p>Total 46.0</p>	<p>20 Shots</p>  <p style="text-align: center;">8</p>	<p>6: *10.5 →</p> <p>7: 10.2 →</p> <p>8: 9.1 ↗</p> <p>9: *10.7 →</p> <p>10: 9.8 ↗</p> <hr/> <p>Series 48.0</p> <p>Total 94.0</p>
<p>20 Shots</p>  <p style="text-align: center;">8</p>	<p>11: *10.3 ↑</p> <p>12: 9.4 ↗</p> <p>13: 9.9 ↗</p> <p>14: *10.3 ↙</p> <p>15: *10.4 ↙</p> <hr/> <p>Series 48.0</p> <p>Total 142.0</p>	<p>20 Shots</p>  <p style="text-align: center;">8</p>	<p>16: 9.3 ↗</p> <p>17: 10.0 ↙</p> <p>18: 9.7 ↙</p> <p>19: 9.1 ↗</p> <p>20: *10.5 ↗</p> <hr/> <p>Series 47.0</p> <p>Total 189.0</p>

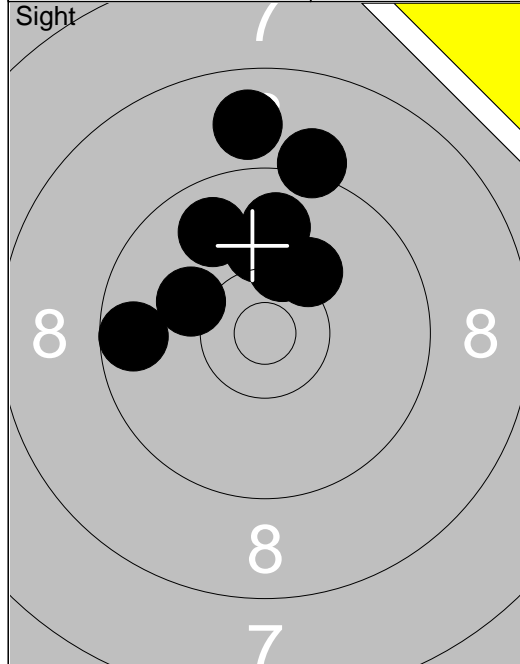

1:	8.9	↑
2:	9.8	↖
3:	10.1	↑
4:	9.2	↑
5:	10.1	↖
6:	9.6	←
7:	10.3	↑
8:	9.9	↑
9:	10.2	↗

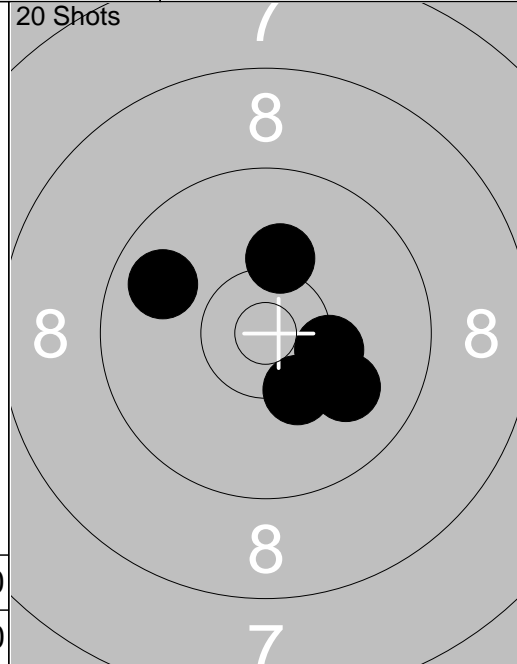

20 Shots		
6:	9.9	↓
7:	10.2	↖
8:	9.0	→
9:	9.6	↗
10:	9.9	↖

1:	*10.3	→
2:	9.8	↖
3:	*10.3	↘
4:	10.0	→
5:	10.2	↑

Series	84.0
Total	0.0

Series	49.0
Total	49.0

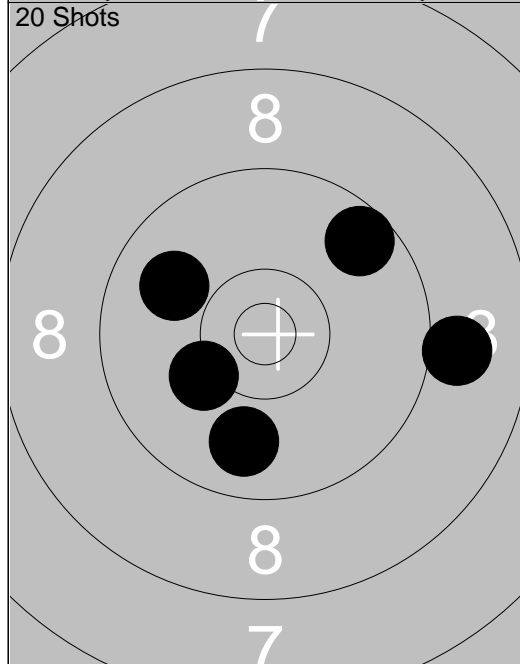

Series	46.0
Total	95.0

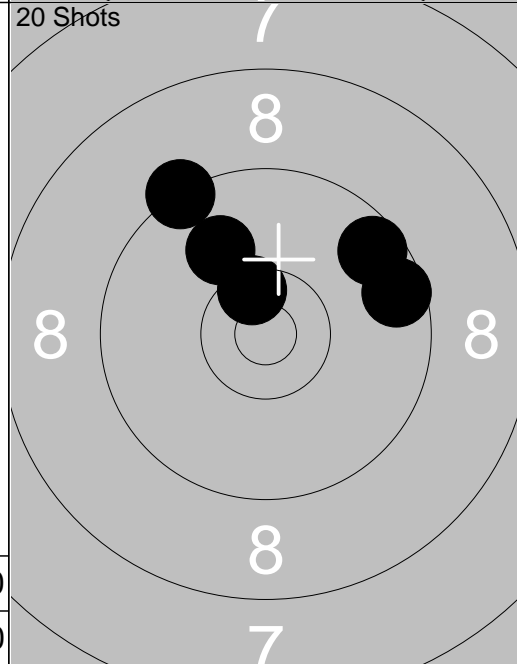

20 Shots		
11:	9.3	↖
12:	*10.5	↗
13:	9.6	→
14:	10.0	↖
15:	9.6	↗

Series	47.0
Total	142.0

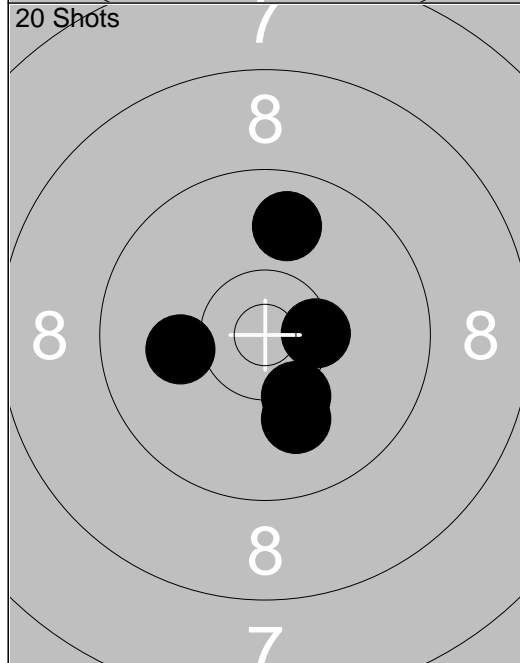

16:	9.8	↑
17:	10.1	↓
18:	10.1	←
19:	10.3	↘
20:	*10.4	→
Series	49.0	
Total	191.0	

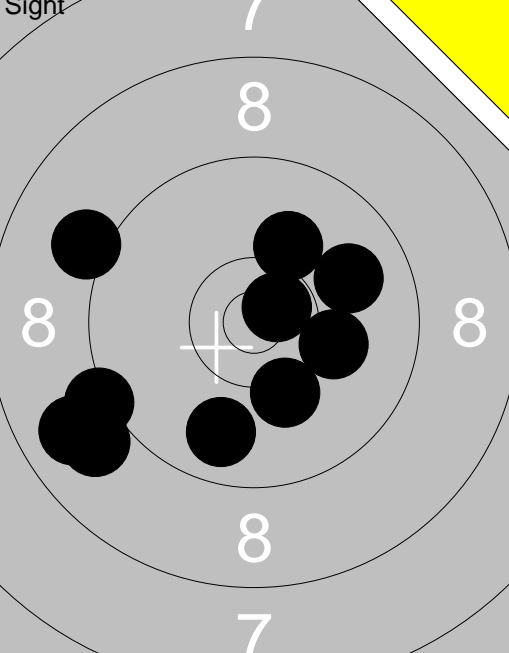
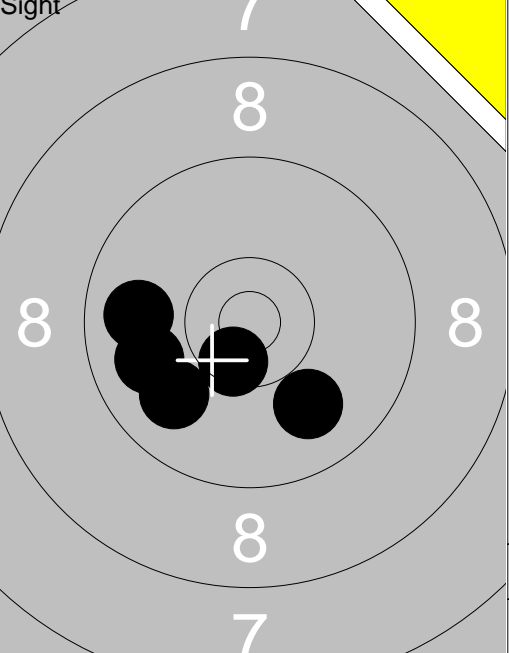
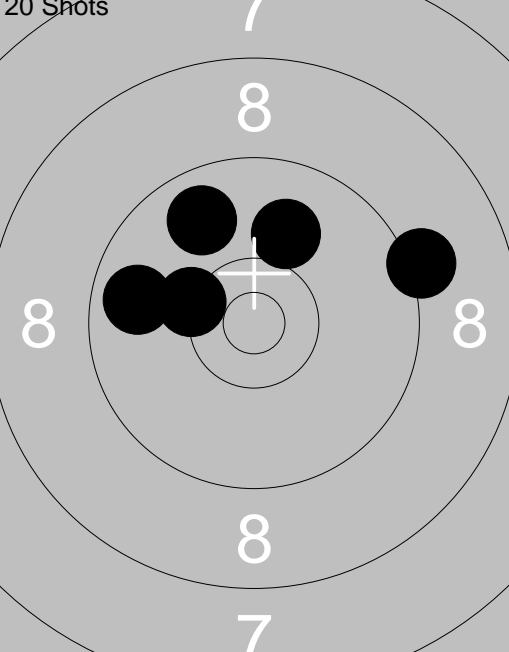
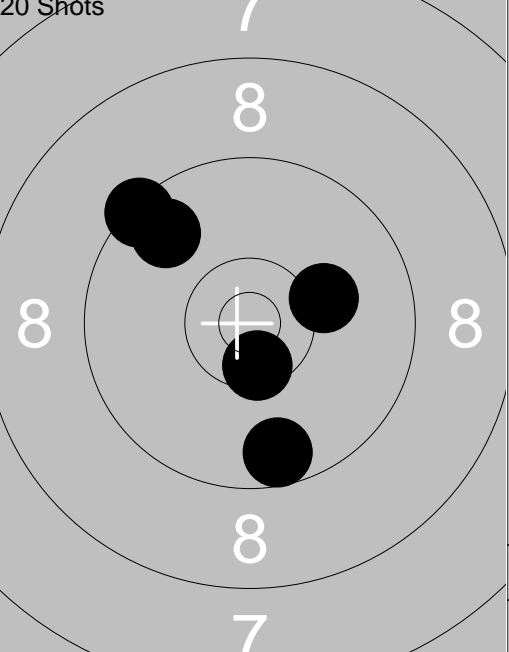
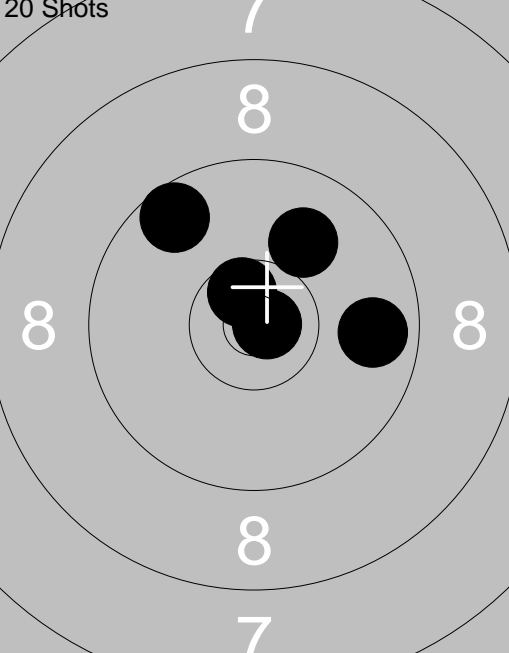
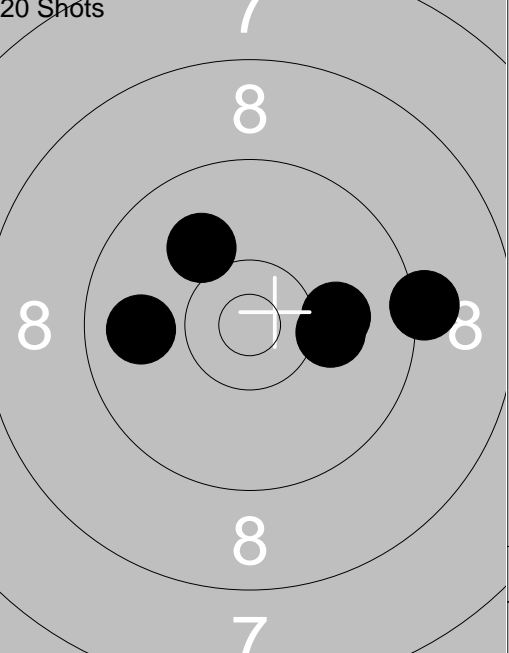
<p>Sight</p> 	<p>1: 9.0 ↙ 2: 8.8 ↙ 3: 9.1 ↙ 4: 10.1 → 5: 9.8 ↓ 6: 9.2 ↙ 7: 10.2 ↓ 8: 9.9 → 9: *10.7 ↗ 10: 10.1 ↗</p> <p>Series 93.0 Total 0.0</p>	<p>Sight</p> 	<p>11: 9.9 ↙ 12: 10.0 ↓ 13: *10.5 ↓ 14: 9.8 ↙ 15: 9.9 ↙</p> <p>Series 47.0 Total 0.0</p>
<p>20 Shots</p> 	<p>1: 9.8 ↙ 2: 9.2 → 3: 9.8 ↗ 4: 10.0 ↗ 5: *10.3 ↙</p> <p>Series 47.0 Total 47.0</p>	<p>20 Shots</p> 	<p>6: 9.7 ↗ 7: 9.4 ↗ 8: 9.6 ↓ 9: *10.5 ↓ 10: 10.2 →</p> <p>Series 47.0 Total 94.0</p>
<p>20 Shots</p> 	<p>11: *10.8 → 12: 9.8 → 13: 10.0 ↗ 14: 9.6 ↗ 15: *10.6 ↗</p> <p>Series 48.0 Total 142.0</p>	<p>20 Shots</p> 	<p>16: 9.9 ↙ 17: 10.0 ↗ 18: 10.1 → 19: 10.1 → 20: 9.2 →</p> <p>Series 48.0 Total 190.0</p>

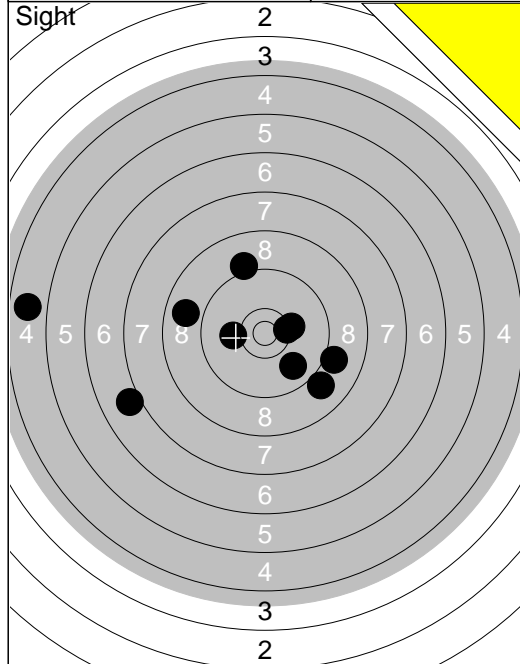

1:	4.8	←
2:	7.0	←
3:	9.8	↘
4:	9.0	↘
5:	9.1	→
6:	8.8	←
7:	10.1	←
8:	9.1	↑
9:	10.2	→
10:	*10.4	→

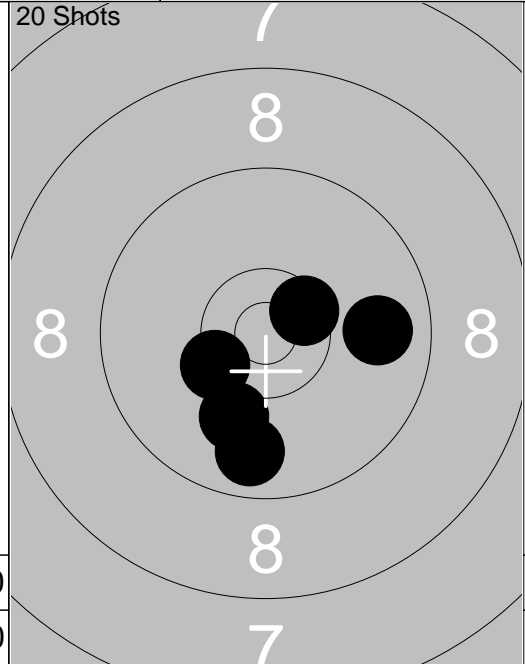

1:	*10.4	↙
2:	9.8	→
3:	10.1	↘
4:	9.8	↘
5:	*10.5	↗

Series	85.0
Total	0.0

Series	48.0
Total	48.0

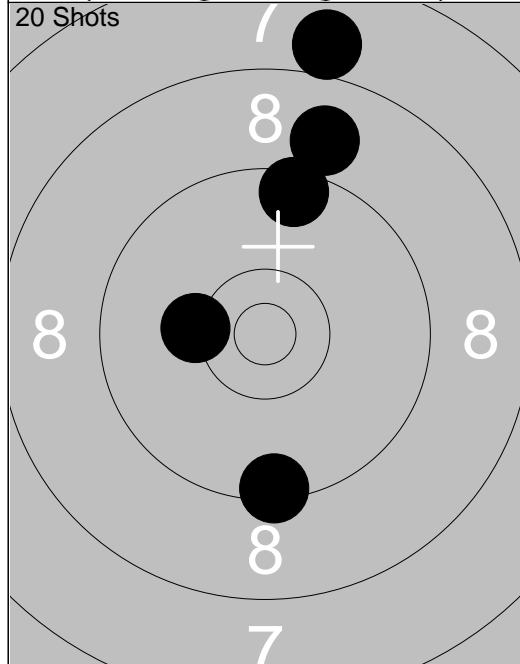

6:	8.9	↑
7:	9.4	↓
8:	8.0	↑
9:	9.5	↑
10:	10.2	←

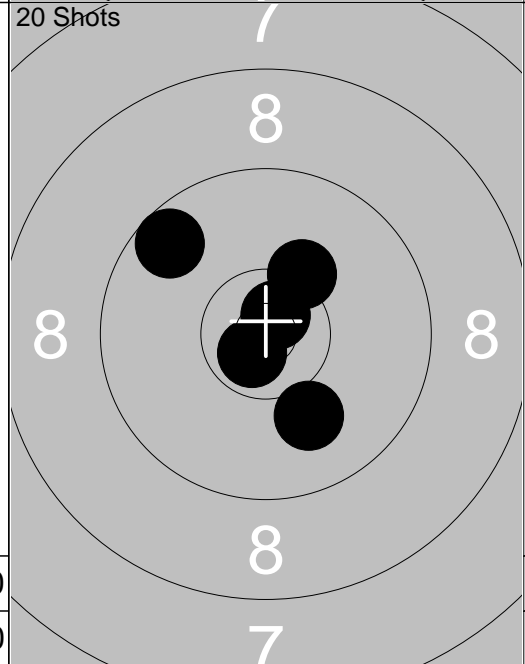

11:	10.0	↘
12:	*10.7	↙
13:	9.6	↖
14:	10.3	↗
15:	*10.7	↗

Series	44.0
Total	92.0

Series	49.0
Total	141.0

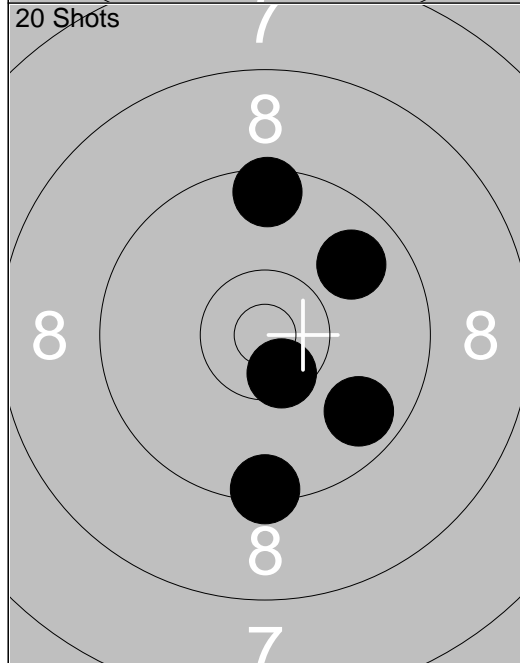

16:	9.4	↓
17:	9.5	↑
18:	9.8	↗
19:	9.7	↘
20:	*10.5	↘

Series	46.0
Total	187.0

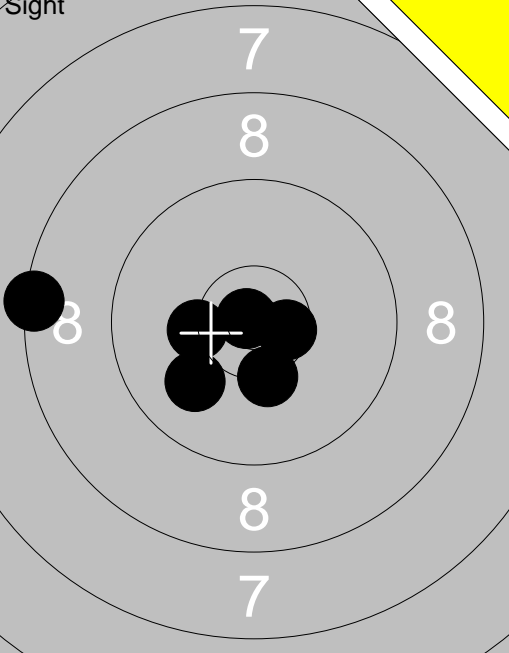
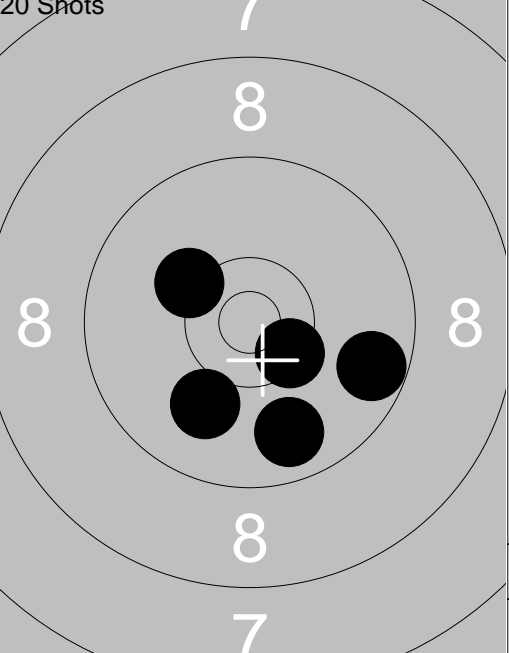
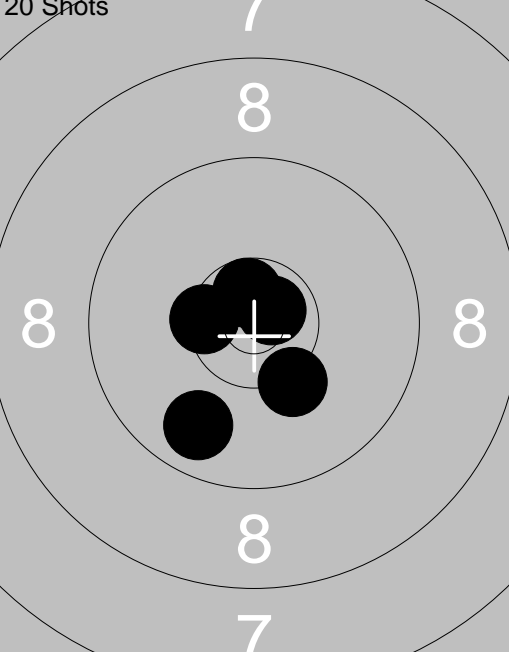
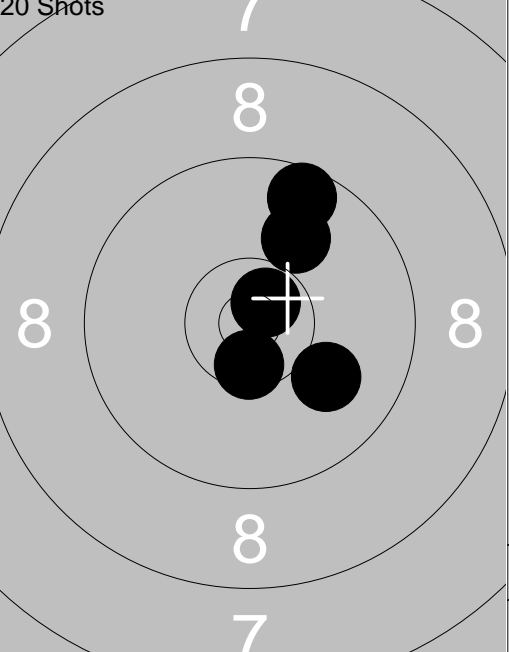
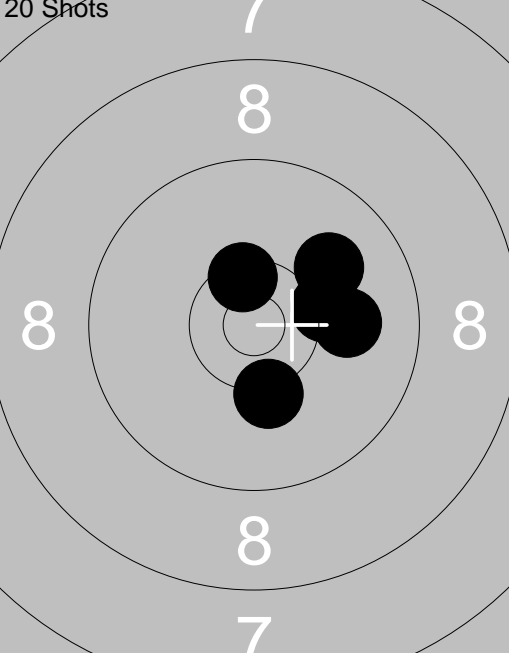
<p>Sight</p>  <p style="text-align: center;">7 8 8 8 7</p>	<p>1: 8.4 ←</p> <p>2: *10.9 ↘</p> <p>3: *10.6 →</p> <p>4: 10.3 ←</p> <p>5: *10.3 ↓</p> <p>6: 10.0 ↙</p>	<p>20 Shots</p>  <p style="text-align: center;">7 8 8 8 7</p>		<p>1: 10.2 ↖</p> <p>2: 9.8 ↓</p> <p>3: 10.0 ↓</p> <p>4: *10.4 ↘</p> <p>5: 9.7 →</p>
Series 58.0		Series 48.0		
Total 0.0		Total 48.0		
<p>20 Shots</p>  <p style="text-align: center;">7 8 8 8 7</p>	<p>6: 10.2 ↓</p> <p>7: 9.8 ↓</p> <p>8: *10.7 ↗</p> <p>9: *10.6 ↗</p> <p>10: *10.4 ←</p>	<p>20 Shots</p>  <p style="text-align: center;">7 8 8 8 7</p>		<p>11: 10.0 ↗</p> <p>12: 9.6 ↗</p> <p>13: *10.7 ↗</p> <p>14: *10.5 ↓</p> <p>15: 10.0 ↘</p>
Series 49.0		Series 49.0		
Total 97.0		Total 146.0		
<p>20 Shots</p>  <p style="text-align: center;">7 8 8 8 7</p>	<p>16: *10.5 ↗</p> <p>17: 10.0 →</p> <p>18: 10.0 ↗</p> <p>19: 10.3 ↓</p> <p>20: 10.2 →</p>			
Series 50.0				
Total 196.0				

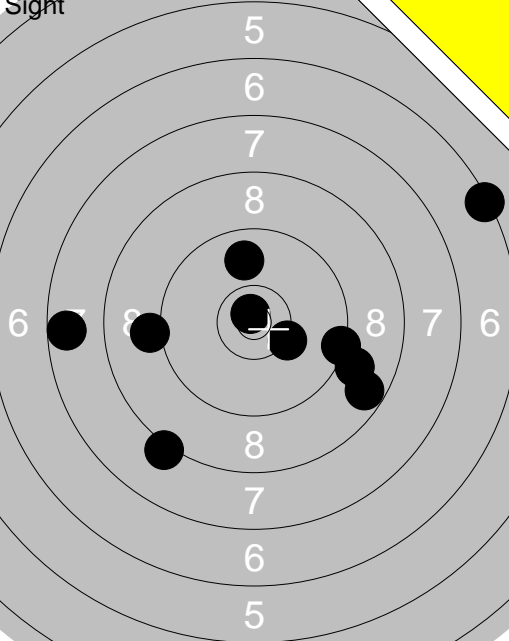
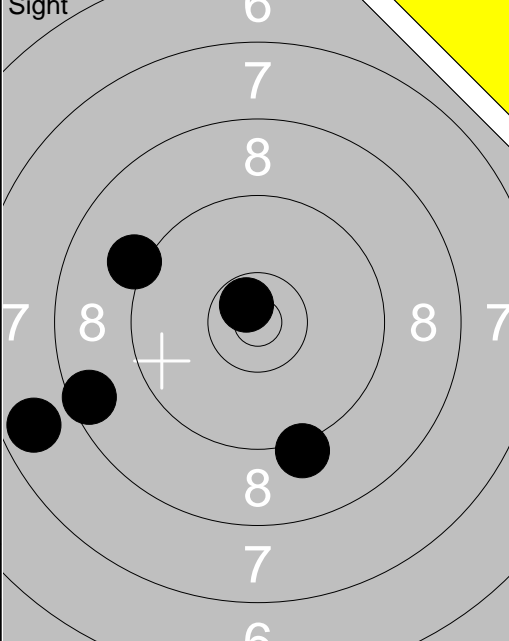
 <p>Sight</p>	<p>1: 6.4 →</p> <p>2: 8.7 →</p> <p>3: 9.1 ←</p> <p>4: 7.6 ←</p> <p>5: 9.4 →</p> <p>6: 9.0 →</p> <p>7: 9.8 ↑</p> <p>8: *10.8 ↖</p> <p>9: 8.2 ↓</p> <p>10: 10.3 →</p>	 <p>Sight</p>	<p>11: 7.7 ←</p> <p>12: *10.7 ↖</p> <p>13: 9.2 ↓</p> <p>14: 8.6 ←</p> <p>15: 9.2 ←</p>
Series 85.0		Series 43.0	
Total 0.0		Total 0.0	

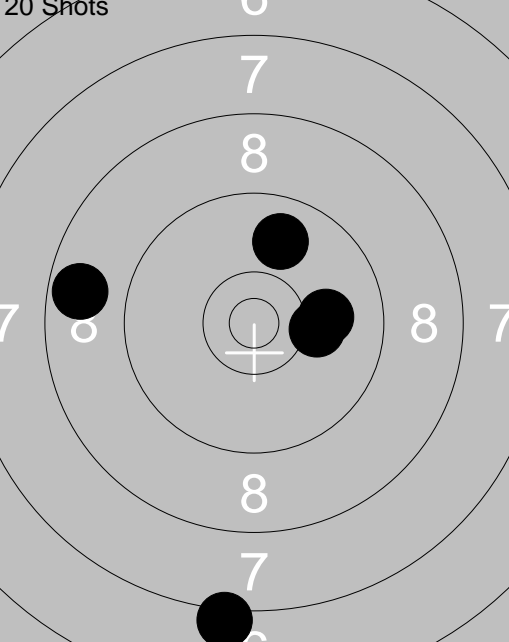
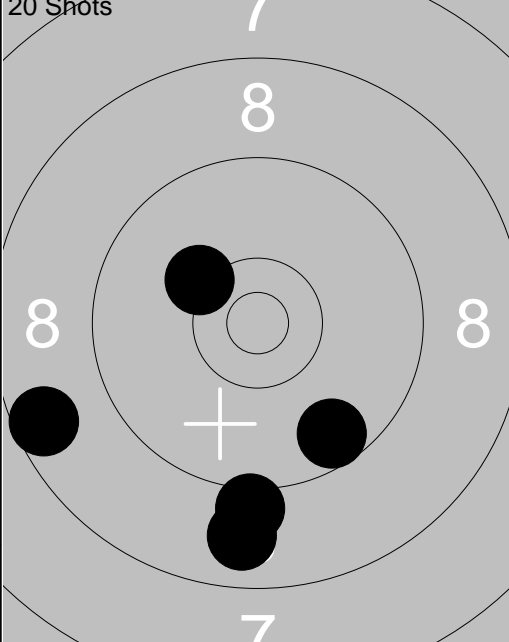
 <p>20 Shots</p>	<p>1: 10.2 →</p> <p>2: 10.0 →</p> <p>3: 9.9 ↑</p> <p>4: 8.7 ←</p> <p>5: 7.2 ↓</p>	 <p>20 Shots</p>	<p>6: 9.1 ↓</p> <p>7: 8.6 ←</p> <p>8: 8.8 ↓</p> <p>9: 10.2 ↖</p> <p>10: 9.6 ↓</p>
Series 44.0		Series 44.0	
Total 44.0		Total 88.0	

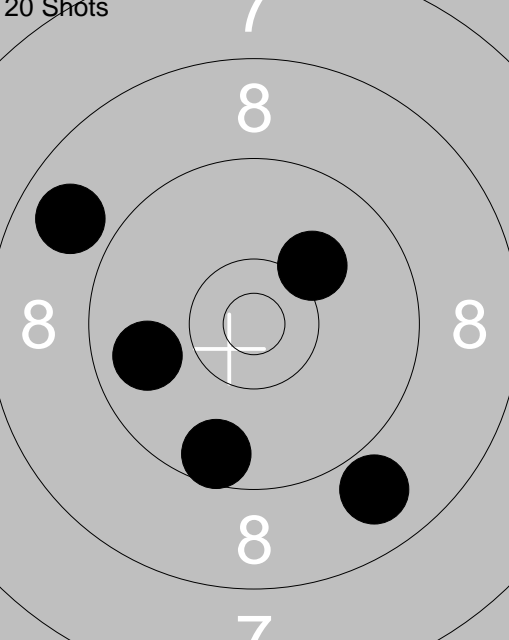
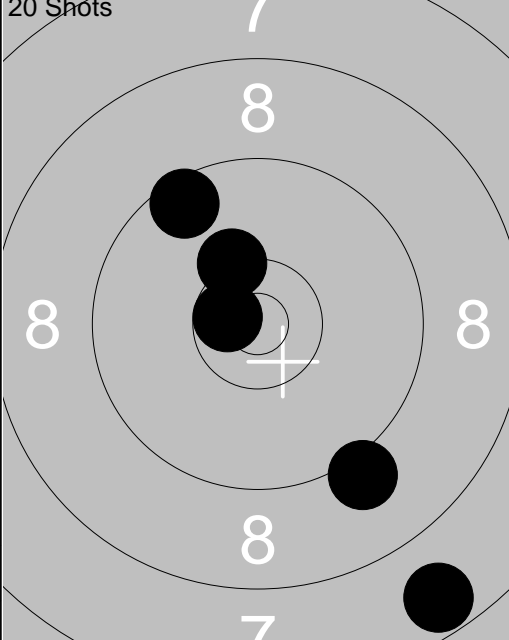
 <p>20 Shots</p>	<p>11: 10.1 ↗</p> <p>12: 8.8 ←</p> <p>13: 8.9 ↓</p> <p>14: 9.8 ←</p> <p>15: 9.6 ↓</p>	 <p>20 Shots</p>	<p>16: *10.6 ↖</p> <p>17: *10.3 ↖</p> <p>18: 7.7 ↓</p> <p>19: 9.5 ↑</p> <p>20: 9.1 ↓</p>
Series 44.0		Series 45.0	
Total 132.0		Total 177.0	

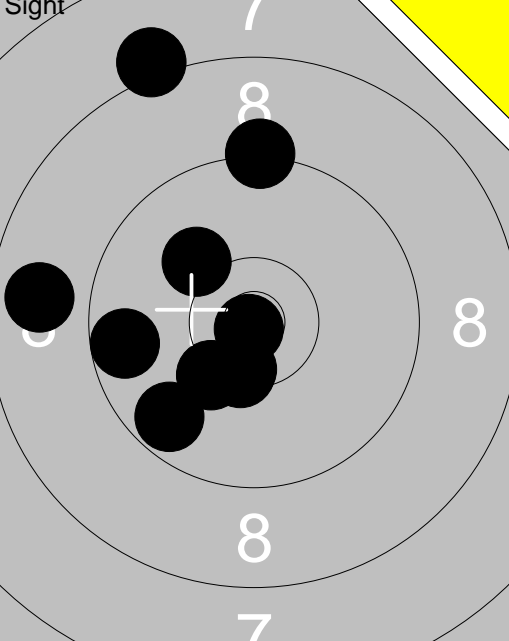
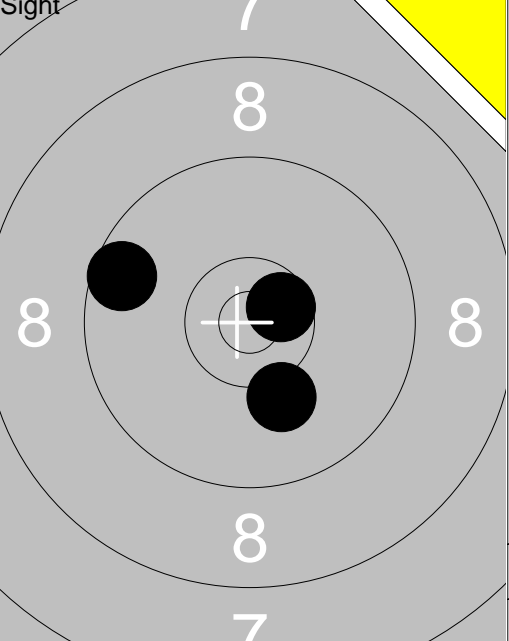
 <p>Sight</p>	<p>1: *10.9 ↘ 2: 9.3 ↑ 3: 8.2 ↗ 4: 10.3 ↘ 5: *10.5 ↘ 6: 9.7 ↘ 7: 8.8 ← 8: 9.6 ← 9: *10.4 ↘ 10: 10.1 ↖</p> <p>Series 93.0 Total 0.0</p>	 <p>Sight</p>	<p>11: 9.6 ← 12: 10.1 ↘ 13: *10.6 ↗</p> <p>Series 29.0 Total 0.0</p>
---	--	---	--

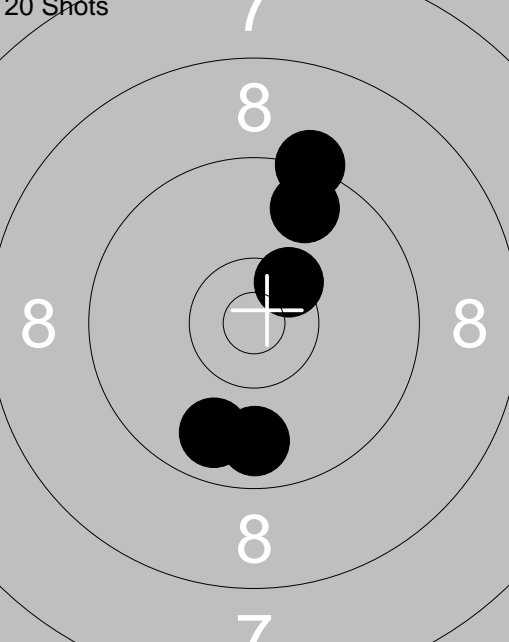
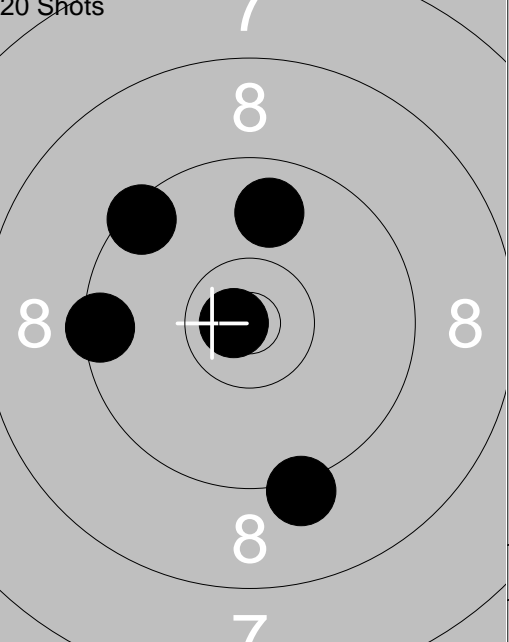
 <p>20 Shots</p>	<p>1: *10.4 ↗ 2: 9.7 ↑ 3: 9.8 ↘ 4: 9.3 ↑ 5: 9.8 ↘</p> <p>Series 46.0 Total 46.0</p>	 <p>20 Shots</p>	<p>6: 9.2 ↘ 7: *10.8 ← 8: 9.8 ↑ 9: 9.5 ↖ 10: 9.5 ←</p> <p>Series 46.0 Total 92.0</p>
---	---	---	--

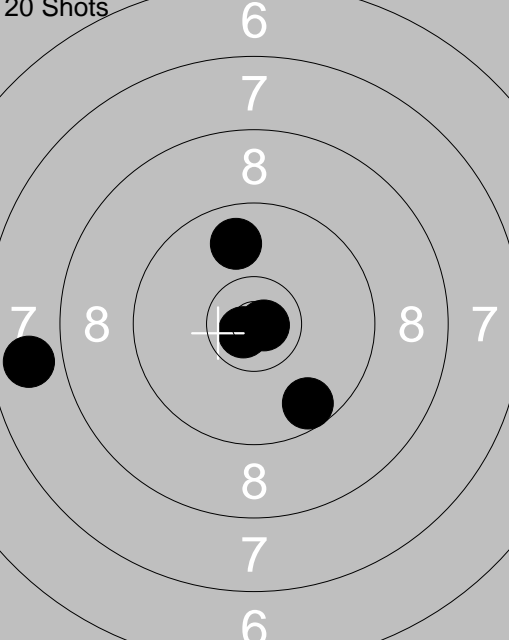
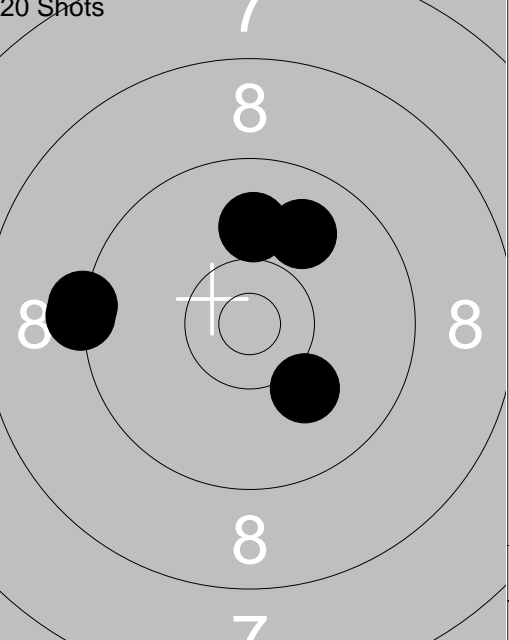
 <p>20 Shots</p>	<p>11: *10.8 → 12: 7.8 ← 13: *10.8 ↘ 14: 9.6 ↘ 15: 9.8 ↑</p> <p>Series 45.0 Total 137.0</p>	 <p>20 Shots</p>	<p>16: 9.3 ← 17: 9.3 ← 18: 10.1 ↘ 19: 9.9 ↑ 20: 10.0 ↑</p> <p>Series 47.0 Total 184.0</p>
--	---	--	---

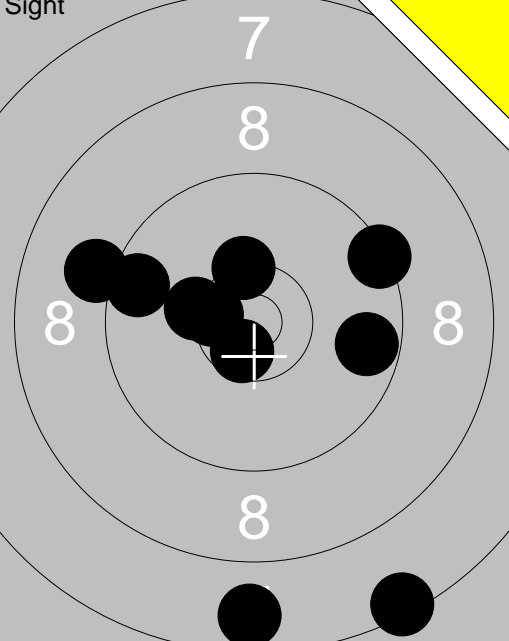
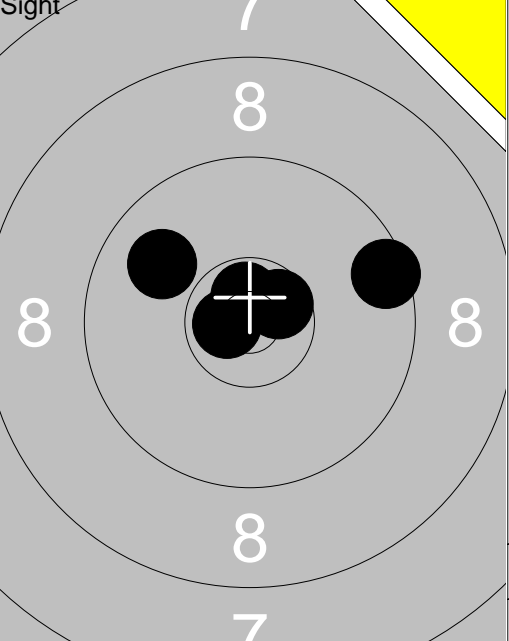
Sight 	1: 7.4 ↓	Sight 	11: *10.6 ↗
	2: 7.7 ↓		12: *10.7 ↑
	3: 10.3 ↙		13: 9.5 →
	4: 9.4 ↗		14: 9.9 ↖
	5: 9.7 →		15: *10.7 ↖
	6: 9.1 ↖		
	7: *10.3 ↑		
	8: 9.6 ↖		
	9: *10.6 ↓		
	10: *10.5 ↖		
	Series 90.0		Series 48.0
	Total 0.0		Total 0.0

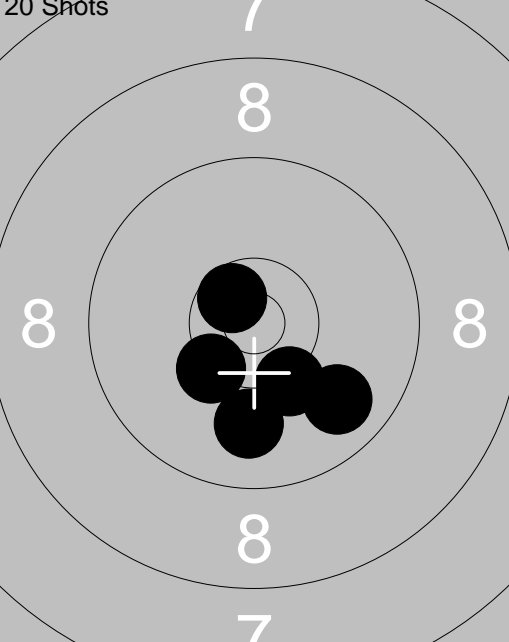
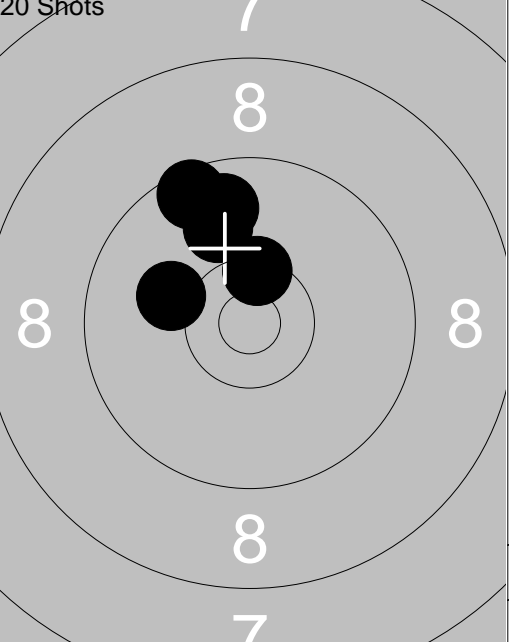
20 Shots 	1: 9.9 ↓	20 Shots 	6: 10.1 ↖
	2: 9.8 ↓		7: *10.4 ↑
	3: *10.3 ↘		8: 9.8 ↑
	4: 10.3 ↓		9: 9.5 ↖
	5: *10.6 ↖		10: 9.9 ↑
	Series 48.0		Series 47.0
	Total 48.0		Total 95.0

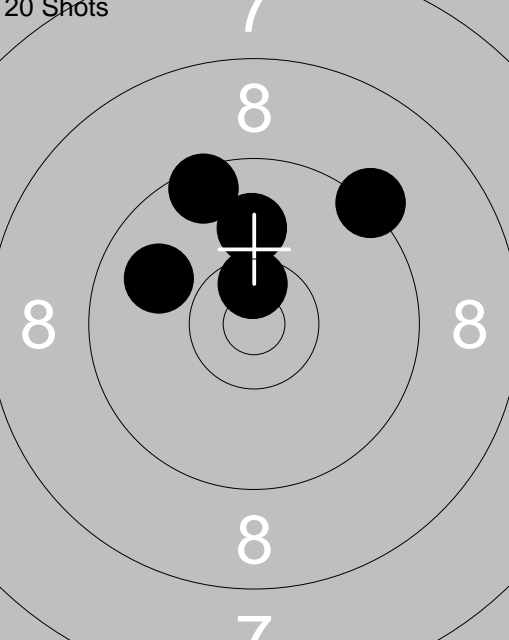
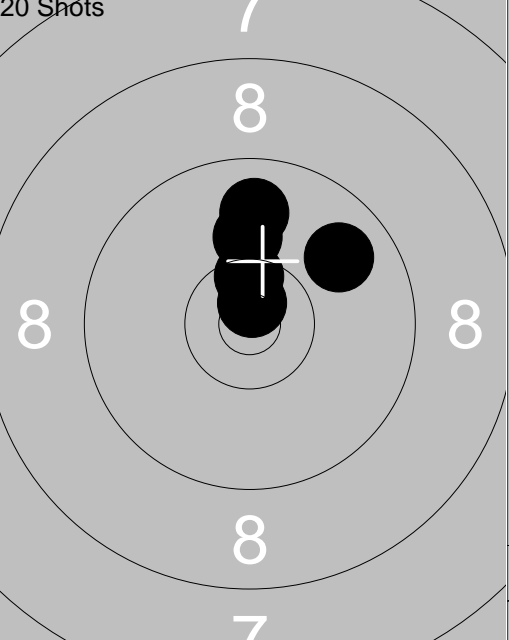
20 Shots 	11: 10.0 ↑	20 Shots 	16: 10.1 ↑
	12: 9.5 ↑		17: 9.8 ↗
	13: 9.3 ↗		18: 9.8 ↑
	14: 9.9 ↖		19: *10.7 ↑
	15: *10.5 ↑		20: *10.5 ↑
	Series 47.0		Series 48.0
	Total 142.0		Total 190.0

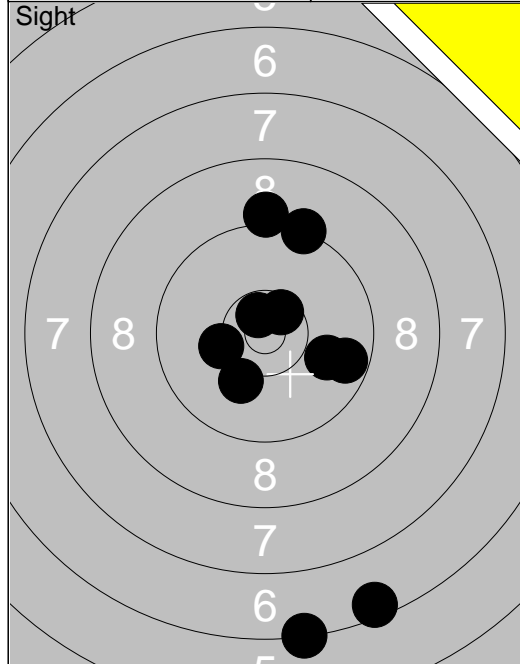

1:	6.3	↓
2:	6.5	↓
3:	9.1	↑
4:	9.3	↑
5:	9.7	→
6:	9.9	→
7:	10.1	↓
8:	*10.7	↖
9:	*10.5	↗
10:	10.3	←
Series	88.0	
Total	0.0	

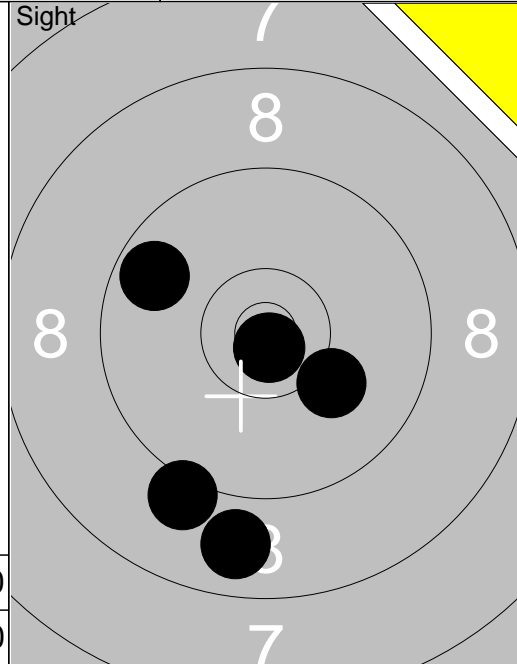

11:	8.8	↓
12:	10.1	↘
13:	*10.8	↓
14:	9.7	↖
15:	9.1	↓
16:	*10.8	↓
Series	56.0	
Total	0.0	

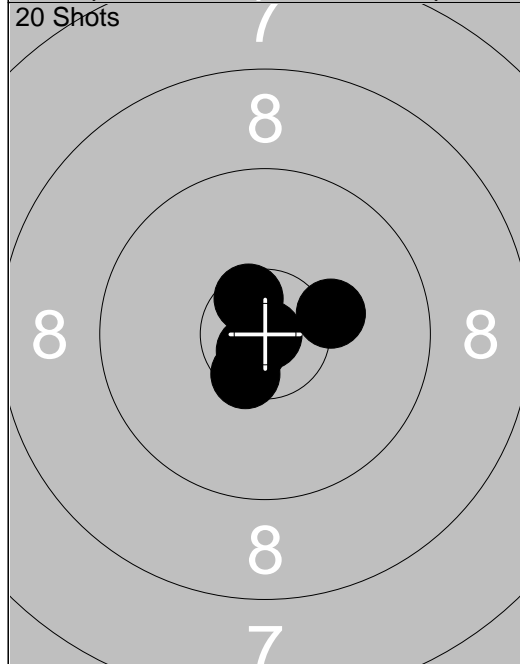

1:	*10.9	→
2:	10.3	→
3:	*10.6	↖
4:	*10.5	↓
5:	*10.7	↓
Series	50.0	
Total	50.0	

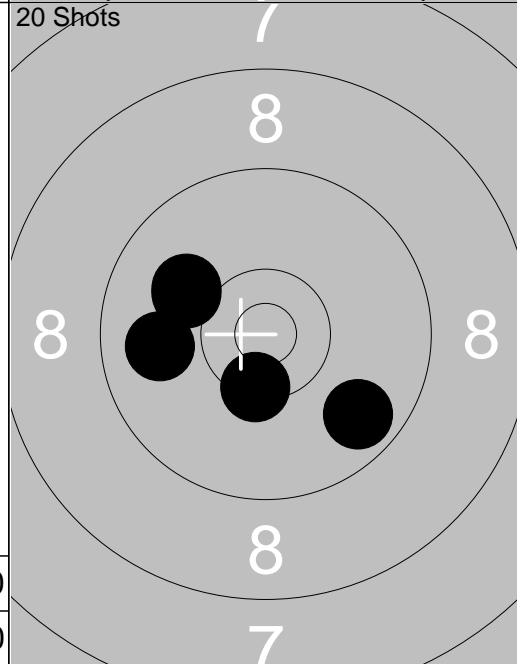

6:	10.1	↖
7:	9.9	←
8:	*10.4	↓
9:	9.7	↘
10:	10.0	↖
Series	48.0	
Total	98.0	

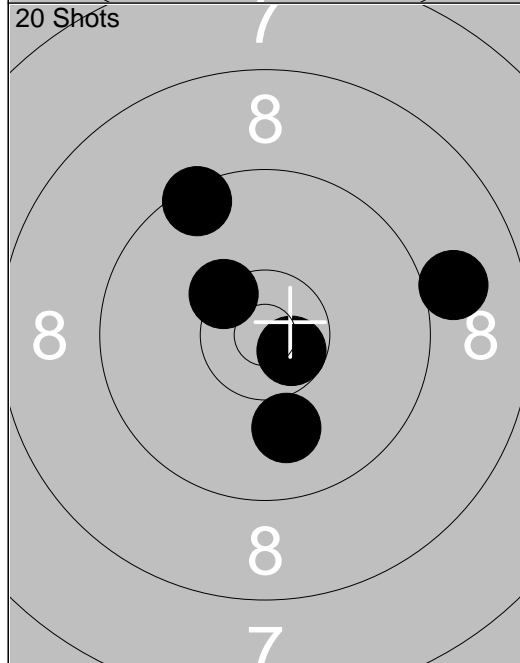

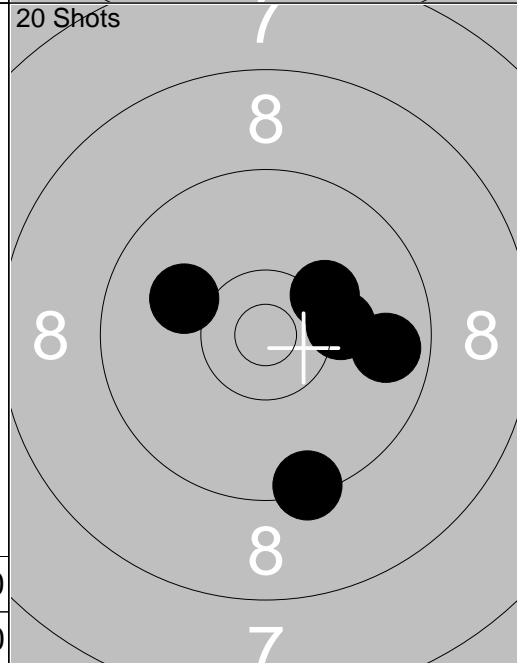

11:	9.0	→
12:	*10.4	↖
13:	9.5	↑
14:	*10.6	↘
15:	10.0	↓
Series	48.0	
Total	146.0	

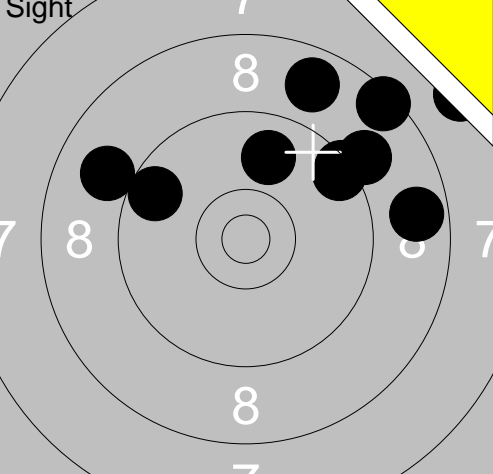
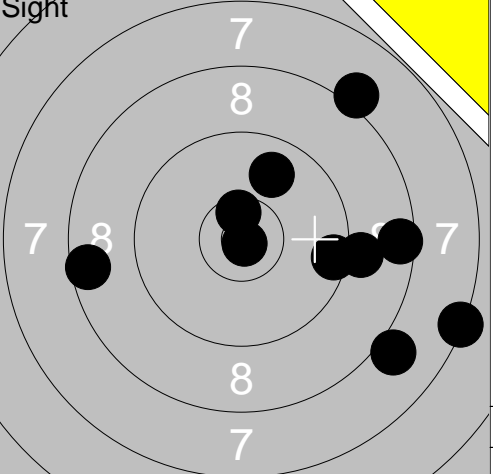

16:	9.7	→
17:	10.1	↖
18:	9.4	↓
19:	10.2	↗
20:	10.2	→
Series	48.0	
Total	194.0	

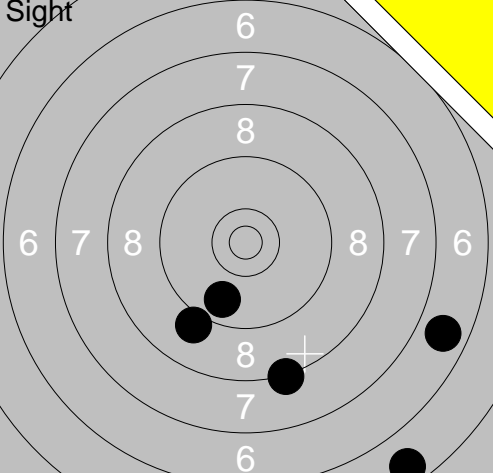
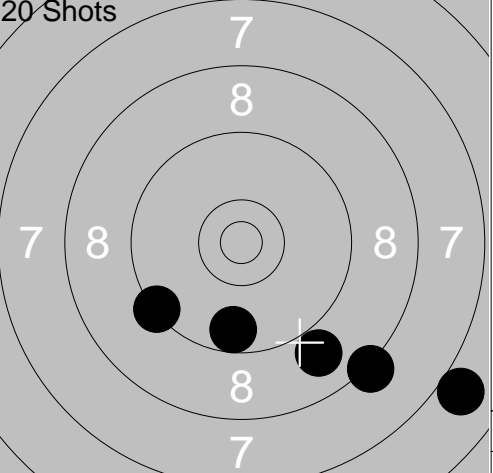
	<table border="1" style="width:100%; border-collapse: collapse;"> <tr><td>1:</td><td>7.6</td><td>↗</td></tr> <tr><td>2:</td><td>8.4</td><td>↗</td></tr> <tr><td>3:</td><td>8.8</td><td>↑</td></tr> <tr><td>4:</td><td>9.9</td><td>↑</td></tr> <tr><td>5:</td><td>8.7</td><td>→</td></tr> <tr><td>6:</td><td>9.4</td><td>↗</td></tr> <tr><td>7:</td><td>9.0</td><td>↖</td></tr> <tr><td>8:</td><td>9.6</td><td>↖</td></tr> <tr><td>9:</td><td>9.1</td><td>↗</td></tr> <tr><td>10:</td><td>9.5</td><td>↗</td></tr> <tr><td colspan="2">Series</td><td>85.0</td></tr> <tr><td colspan="2">Total</td><td>0.0</td></tr> </table>	1:	7.6	↗	2:	8.4	↗	3:	8.8	↑	4:	9.9	↑	5:	8.7	→	6:	9.4	↗	7:	9.0	↖	8:	9.6	↖	9:	9.1	↗	10:	9.5	↗	Series		85.0	Total		0.0	 <table border="1" style="width:100%; border-collapse: collapse;"> <tr><td>11:</td><td>8.1</td><td>↗</td></tr> <tr><td>12:</td><td>9.9</td><td>↗</td></tr> <tr><td>13:</td><td>8.0</td><td>↘</td></tr> <tr><td>14:</td><td>*10.5</td><td>↑</td></tr> <tr><td>15:</td><td>7.3</td><td>↘</td></tr> <tr><td>16:</td><td>9.1</td><td>→</td></tr> <tr><td>17:</td><td>8.5</td><td>→</td></tr> <tr><td>18:</td><td>8.6</td><td>↖</td></tr> <tr><td>19:</td><td>*10.9</td><td>↘</td></tr> <tr><td>20:</td><td>9.5</td><td>→</td></tr> <tr><td colspan="2">Series</td><td>86.0</td></tr> <tr><td colspan="2">Total</td><td>0.0</td></tr> </table>	11:	8.1	↗	12:	9.9	↗	13:	8.0	↘	14:	*10.5	↑	15:	7.3	↘	16:	9.1	→	17:	8.5	→	18:	8.6	↖	19:	*10.9	↘	20:	9.5	→	Series		86.0	Total		0.0
1:	7.6	↗																																																																								
2:	8.4	↗																																																																								
3:	8.8	↑																																																																								
4:	9.9	↑																																																																								
5:	8.7	→																																																																								
6:	9.4	↗																																																																								
7:	9.0	↖																																																																								
8:	9.6	↖																																																																								
9:	9.1	↗																																																																								
10:	9.5	↗																																																																								
Series		85.0																																																																								
Total		0.0																																																																								
11:	8.1	↗																																																																								
12:	9.9	↗																																																																								
13:	8.0	↘																																																																								
14:	*10.5	↑																																																																								
15:	7.3	↘																																																																								
16:	9.1	→																																																																								
17:	8.5	→																																																																								
18:	8.6	↖																																																																								
19:	*10.9	↘																																																																								
20:	9.5	→																																																																								
Series		86.0																																																																								
Total		0.0																																																																								

 <table border="1" style="width:100%; border-collapse: collapse;"> <tr><td>21:</td><td>9.8</td><td>↘</td></tr> <tr><td>22:</td><td>9.1</td><td>↘</td></tr> <tr><td>23:</td><td>8.3</td><td>↘</td></tr> <tr><td>24:</td><td>6.8</td><td>↘</td></tr> <tr><td>25:</td><td>5.7</td><td>↘</td></tr> <tr><td colspan="2">Series</td><td>37.0</td></tr> <tr><td colspan="2">Total</td><td>0.0</td></tr> </table>	21:	9.8	↘	22:	9.1	↘	23:	8.3	↘	24:	6.8	↘	25:	5.7	↘	Series		37.0	Total		0.0	 <table border="1" style="width:100%; border-collapse: collapse;"> <tr><td>1:</td><td>9.3</td><td>↖</td></tr> <tr><td>2:</td><td>7.0</td><td>↘</td></tr> <tr><td>3:</td><td>8.9</td><td>↘</td></tr> <tr><td>4:</td><td>8.2</td><td>↘</td></tr> <tr><td>5:</td><td>9.6</td><td>↘</td></tr> <tr><td colspan="2">Series</td><td>41.0</td></tr> <tr><td colspan="2">Total</td><td>41.0</td></tr> </table>	1:	9.3	↖	2:	7.0	↘	3:	8.9	↘	4:	8.2	↘	5:	9.6	↘	Series		41.0	Total		41.0
21:	9.8	↘																																									
22:	9.1	↘																																									
23:	8.3	↘																																									
24:	6.8	↘																																									
25:	5.7	↘																																									
Series		37.0																																									
Total		0.0																																									
1:	9.3	↖																																									
2:	7.0	↘																																									
3:	8.9	↘																																									
4:	8.2	↘																																									
5:	9.6	↘																																									
Series		41.0																																									
Total		41.0																																									

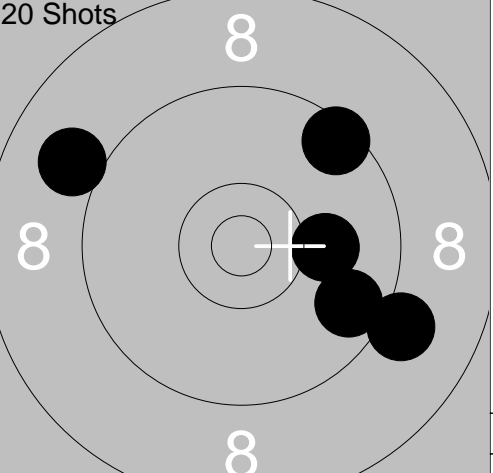
 <table border="1" style="width:100%; border-collapse: collapse;"> <tr><td>6:</td><td>9.2</td><td>↗</td></tr> <tr><td>7:</td><td>9.9</td><td>↘</td></tr> <tr><td>8:</td><td>8.7</td><td>↖</td></tr> <tr><td>9:</td><td>10.1</td><td>↑</td></tr> <tr><td>10:</td><td>8.6</td><td>↘</td></tr> <tr><td colspan="2">Series</td><td>44.0</td></tr> <tr><td colspan="2">Total</td><td>85.0</td></tr> </table>	6:	9.2	↗	7:	9.9	↘	8:	8.7	↖	9:	10.1	↑	10:	8.6	↘	Series		44.0	Total		85.0	 <table border="1" style="width:100%; border-collapse: collapse;"> <tr><td>11:</td><td>10.1</td><td>→</td></tr> <tr><td>12:</td><td>9.7</td><td>↘</td></tr> <tr><td>13:</td><td>9.0</td><td>↗</td></tr> <tr><td>14:</td><td>9.5</td><td>↗</td></tr> <tr><td>15:</td><td>9.1</td><td>↘</td></tr> <tr><td colspan="2">Series</td><td>46.0</td></tr> <tr><td colspan="2">Total</td><td>131.0</td></tr> </table>	11:	10.1	→	12:	9.7	↘	13:	9.0	↗	14:	9.5	↗	15:	9.1	↘	Series		46.0	Total		131.0
6:	9.2	↗																																									
7:	9.9	↘																																									
8:	8.7	↖																																									
9:	10.1	↑																																									
10:	8.6	↘																																									
Series		44.0																																									
Total		85.0																																									
11:	10.1	→																																									
12:	9.7	↘																																									
13:	9.0	↗																																									
14:	9.5	↗																																									
15:	9.1	↘																																									
Series		46.0																																									
Total		131.0																																									

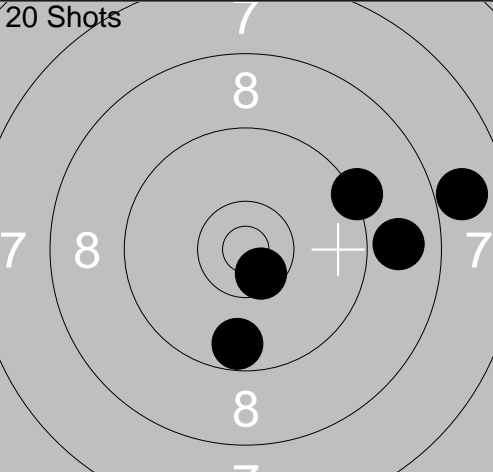
 <table border="1" style="width:100%; border-collapse: collapse;"> <tr><td>16:</td><td>9.7</td><td>↘</td></tr> <tr><td>17:</td><td>9.3</td><td>↗</td></tr> <tr><td>18:</td><td>7.9</td><td>→</td></tr> <tr><td>19:</td><td>*10.6</td><td>↘</td></tr> <tr><td>20:</td><td>8.9</td><td>→</td></tr> <tr><td colspan="2">Series</td><td>43.0</td></tr> <tr><td colspan="2">Total</td><td>174.0</td></tr> </table>	16:	9.7	↘	17:	9.3	↗	18:	7.9	→	19:	*10.6	↘	20:	8.9	→	Series		43.0	Total		174.0	
16:	9.7	↘																				
17:	9.3	↗																				
18:	7.9	→																				
19:	*10.6	↘																				
20:	8.9	→																				
Series		43.0																				
Total		174.0																				

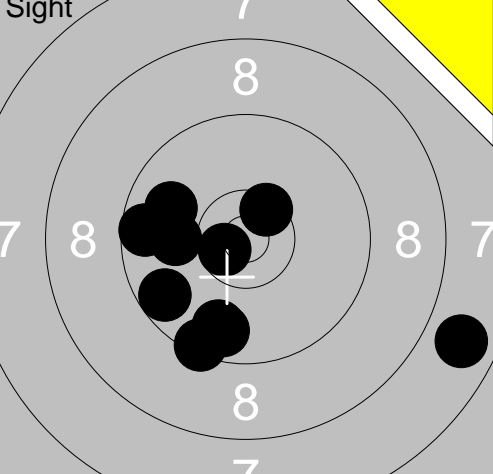
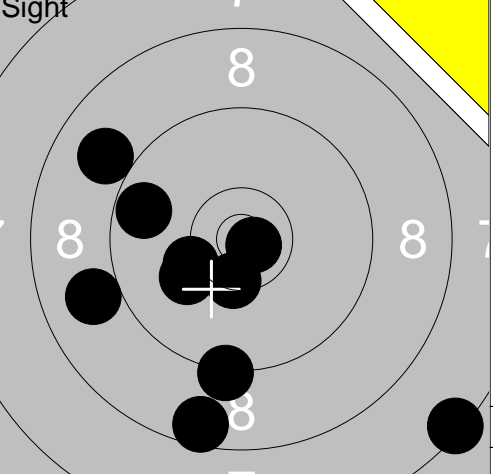
	<table border="1" style="width:100%; border-collapse: collapse;"> <tr><td>1:</td><td>9.4</td><td>↓</td></tr> <tr><td>2:</td><td>9.6</td><td>←</td></tr> <tr><td>3:</td><td>*10.6</td><td>←</td></tr> <tr><td>4:</td><td>10.0</td><td>←</td></tr> <tr><td>5:</td><td>9.7</td><td>↓</td></tr> <tr><td>6:</td><td>9.6</td><td>←</td></tr> <tr><td>7:</td><td>*10.5</td><td>↗</td></tr> <tr><td>8:</td><td>9.9</td><td>←</td></tr> <tr><td>9:</td><td>9.7</td><td>↓</td></tr> <tr><td>10:</td><td>7.8</td><td>↘</td></tr> <tr><td colspan="2">Series</td><td style="text-align:right;">91.0</td></tr> <tr><td colspan="2">Total</td><td style="text-align:right;">0.0</td></tr> </table>	1:	9.4	↓	2:	9.6	←	3:	*10.6	←	4:	10.0	←	5:	9.7	↓	6:	9.6	←	7:	*10.5	↗	8:	9.9	←	9:	9.7	↓	10:	7.8	↘	Series		91.0	Total		0.0		<table border="1" style="width:100%; border-collapse: collapse;"> <tr><td>11:</td><td>9.0</td><td>←</td></tr> <tr><td>12:</td><td>9.3</td><td>↓</td></tr> <tr><td>13:</td><td>7.4</td><td>↘</td></tr> <tr><td>14:</td><td>10.1</td><td>←</td></tr> <tr><td>15:</td><td>*10.8</td><td>↗</td></tr> <tr><td>16:</td><td>8.9</td><td>↖</td></tr> <tr><td>17:</td><td>8.6</td><td>↓</td></tr> <tr><td>18:</td><td>10.2</td><td>←</td></tr> <tr><td>19:</td><td>9.7</td><td>←</td></tr> <tr><td>20:</td><td>*10.4</td><td>↓</td></tr> <tr><td colspan="2">Series</td><td style="text-align:right;">90.0</td></tr> <tr><td colspan="2">Total</td><td style="text-align:right;">0.0</td></tr> </table>	11:	9.0	←	12:	9.3	↓	13:	7.4	↘	14:	10.1	←	15:	*10.8	↗	16:	8.9	↖	17:	8.6	↓	18:	10.2	←	19:	9.7	←	20:	*10.4	↓	Series		90.0	Total		0.0
1:	9.4	↓																																																																									
2:	9.6	←																																																																									
3:	*10.6	←																																																																									
4:	10.0	←																																																																									
5:	9.7	↓																																																																									
6:	9.6	←																																																																									
7:	*10.5	↗																																																																									
8:	9.9	←																																																																									
9:	9.7	↓																																																																									
10:	7.8	↘																																																																									
Series		91.0																																																																									
Total		0.0																																																																									
11:	9.0	←																																																																									
12:	9.3	↓																																																																									
13:	7.4	↘																																																																									
14:	10.1	←																																																																									
15:	*10.8	↗																																																																									
16:	8.9	↖																																																																									
17:	8.6	↓																																																																									
18:	10.2	←																																																																									
19:	9.7	←																																																																									
20:	*10.4	↓																																																																									
Series		90.0																																																																									
Total		0.0																																																																									

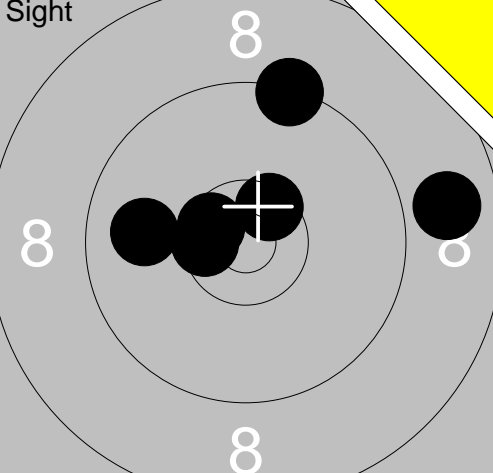
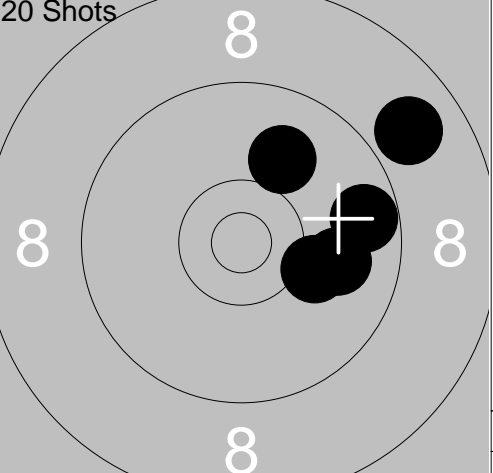
	<table border="1" style="width:100%; border-collapse: collapse;"> <tr><td>21:</td><td>9.9</td><td>←</td></tr> <tr><td>22:</td><td>9.3</td><td>↑</td></tr> <tr><td>23:</td><td>*10.5</td><td>↗</td></tr> <tr><td>24:</td><td>*10.5</td><td>←</td></tr> <tr><td>25:</td><td>*10.6</td><td>↗</td></tr> <tr><td>26:</td><td>8.8</td><td>→</td></tr> <tr><td colspan="2">Series</td><td style="text-align:right;">56.0</td></tr> <tr><td colspan="2">Total</td><td style="text-align:right;">0.0</td></tr> </table>	21:	9.9	←	22:	9.3	↑	23:	*10.5	↗	24:	*10.5	←	25:	*10.6	↗	26:	8.8	→	Series		56.0	Total		0.0		<table border="1" style="width:100%; border-collapse: collapse;"> <tr><td>1:</td><td>9.7</td><td>→</td></tr> <tr><td>2:</td><td>10.0</td><td>↗</td></tr> <tr><td>3:</td><td>9.9</td><td>→</td></tr> <tr><td>4:</td><td>10.2</td><td>→</td></tr> <tr><td>5:</td><td>8.9</td><td>↗</td></tr> <tr><td colspan="2">Series</td><td style="text-align:right;">46.0</td></tr> <tr><td colspan="2">Total</td><td style="text-align:right;">46.0</td></tr> </table>	1:	9.7	→	2:	10.0	↗	3:	9.9	→	4:	10.2	→	5:	8.9	↗	Series		46.0	Total		46.0
21:	9.9	←																																														
22:	9.3	↑																																														
23:	*10.5	↗																																														
24:	*10.5	←																																														
25:	*10.6	↗																																														
26:	8.8	→																																														
Series		56.0																																														
Total		0.0																																														
1:	9.7	→																																														
2:	10.0	↗																																														
3:	9.9	→																																														
4:	10.2	→																																														
5:	8.9	↗																																														
Series		46.0																																														
Total		46.0																																														

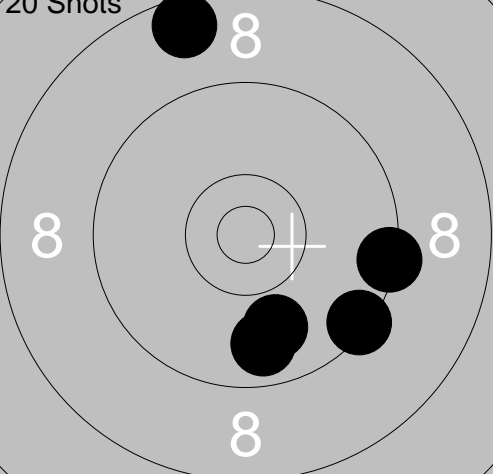
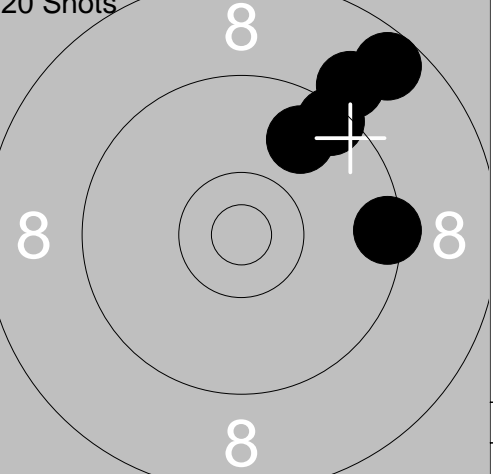
	<table border="1" style="width:100%; border-collapse: collapse;"> <tr><td>6:</td><td>9.8</td><td>↓</td></tr> <tr><td>7:</td><td>9.4</td><td>→</td></tr> <tr><td>8:</td><td>8.6</td><td>↗</td></tr> <tr><td>9:</td><td>9.9</td><td>↓</td></tr> <tr><td>10:</td><td>9.4</td><td>↓</td></tr> <tr><td colspan="2">Series</td><td style="text-align:right;">44.0</td></tr> <tr><td colspan="2">Total</td><td style="text-align:right;">90.0</td></tr> </table>	6:	9.8	↓	7:	9.4	→	8:	8.6	↗	9:	9.9	↓	10:	9.4	↓	Series		44.0	Total		90.0		<table border="1" style="width:100%; border-collapse: collapse;"> <tr><td>11:</td><td>9.0</td><td>↗</td></tr> <tr><td>12:</td><td>9.5</td><td>↗</td></tr> <tr><td>13:</td><td>9.4</td><td>→</td></tr> <tr><td>14:</td><td>9.8</td><td>↗</td></tr> <tr><td>15:</td><td>8.6</td><td>↗</td></tr> <tr><td colspan="2">Series</td><td style="text-align:right;">44.0</td></tr> <tr><td colspan="2">Total</td><td style="text-align:right;">134.0</td></tr> </table>	11:	9.0	↗	12:	9.5	↗	13:	9.4	→	14:	9.8	↗	15:	8.6	↗	Series		44.0	Total		134.0
6:	9.8	↓																																											
7:	9.4	→																																											
8:	8.6	↗																																											
9:	9.9	↓																																											
10:	9.4	↓																																											
Series		44.0																																											
Total		90.0																																											
11:	9.0	↗																																											
12:	9.5	↗																																											
13:	9.4	→																																											
14:	9.8	↗																																											
15:	8.6	↗																																											
Series		44.0																																											
Total		134.0																																											

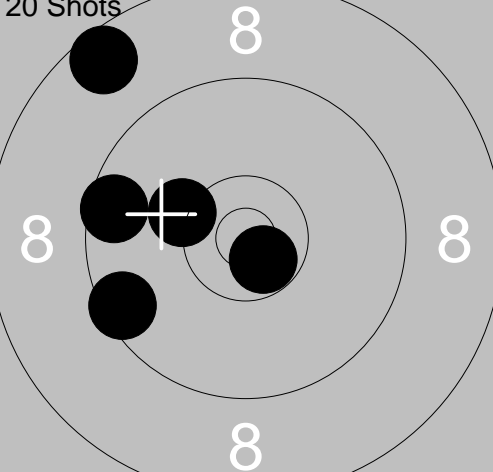
	<table border="1" style="width:100%; border-collapse: collapse;"> <tr><td>16:</td><td>8.6</td><td>↗</td></tr> <tr><td>17:</td><td>9.6</td><td>←</td></tr> <tr><td>18:</td><td>9.5</td><td>←</td></tr> <tr><td>19:</td><td>10.2</td><td>↖</td></tr> <tr><td>20:</td><td>*10.7</td><td>↓</td></tr> <tr><td colspan="2">Series</td><td style="text-align:right;">46.0</td></tr> <tr><td colspan="2">Total</td><td style="text-align:right;">180.0</td></tr> </table>	16:	8.6	↗	17:	9.6	←	18:	9.5	←	19:	10.2	↖	20:	*10.7	↓	Series		46.0	Total		180.0		
16:	8.6	↗																						
17:	9.6	←																						
18:	9.5	←																						
19:	10.2	↖																						
20:	*10.7	↓																						
Series		46.0																						
Total		180.0																						

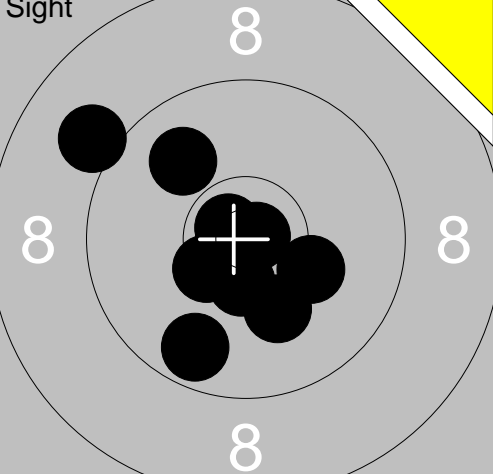
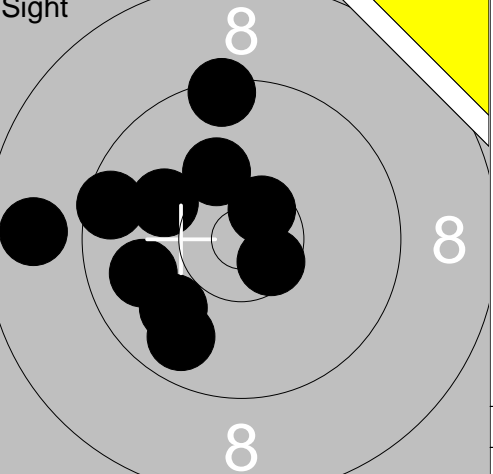

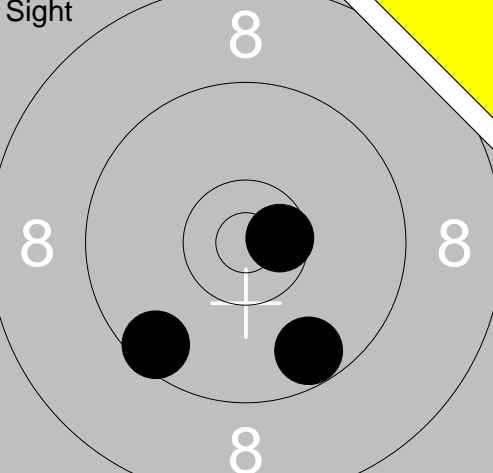
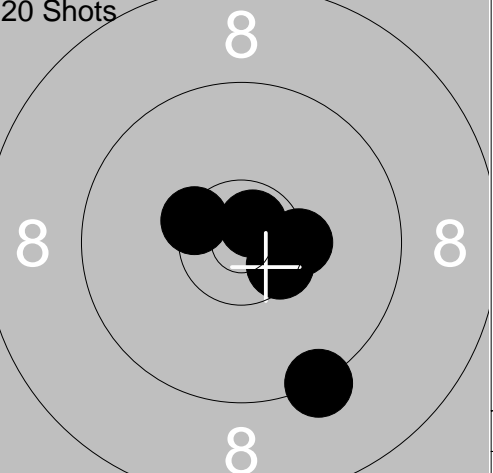
Sight 	Sight 	<table border="1" style="width:100%; border-collapse: collapse;"> <tr><td>1:</td><td>9.1</td><td>↗</td></tr> <tr><td>2:</td><td>*10.8</td><td>←</td></tr> <tr><td>3:</td><td>9.9</td><td>↗</td></tr> <tr><td>4:</td><td>*10.7</td><td>↗</td></tr> <tr><td>5:</td><td>*10.5</td><td>↓</td></tr> <tr><td>6:</td><td>10.2</td><td>↓</td></tr> <tr><td>7:</td><td>*10.4</td><td>←</td></tr> <tr><td>8:</td><td>9.7</td><td>↓</td></tr> <tr><td>9:</td><td>10.2</td><td>→</td></tr> <tr><td>10:</td><td>*10.8</td><td>→</td></tr> <tr><td colspan="2">Series</td><td>97.0</td></tr> <tr><td colspan="2">Total</td><td>0.0</td></tr> </table>	1:	9.1	↗	2:	*10.8	←	3:	9.9	↗	4:	*10.7	↗	5:	*10.5	↓	6:	10.2	↓	7:	*10.4	←	8:	9.7	↓	9:	10.2	→	10:	*10.8	→	Series		97.0	Total		0.0
1:	9.1	↗																																				
2:	*10.8	←																																				
3:	9.9	↗																																				
4:	*10.7	↗																																				
5:	*10.5	↓																																				
6:	10.2	↓																																				
7:	*10.4	←																																				
8:	9.7	↓																																				
9:	10.2	→																																				
10:	*10.8	→																																				
Series		97.0																																				
Total		0.0																																				

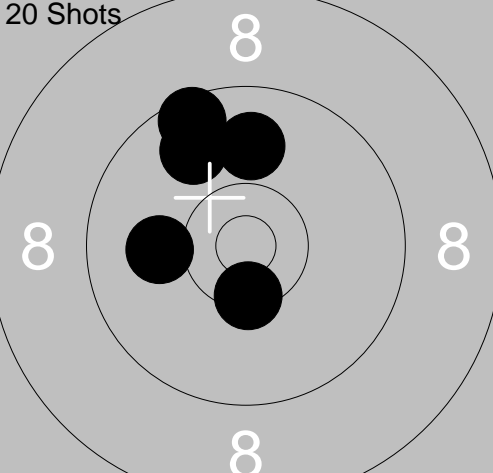
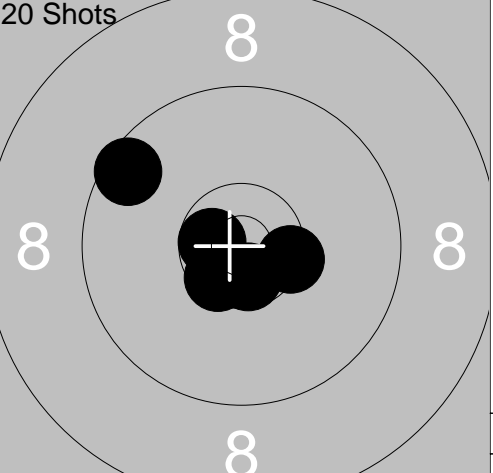
Sight 	20 Shots 	<table border="1" style="width:100%; border-collapse: collapse;"> <tr><td>11:</td><td>10.2</td><td>↗</td></tr> <tr><td>12:</td><td>9.4</td><td>↑</td></tr> <tr><td>13:</td><td>9.8</td><td>↓</td></tr> <tr><td>14:</td><td>*10.6</td><td>↗</td></tr> <tr><td>15:</td><td>*10.6</td><td>↓</td></tr> <tr><td>16:</td><td>10.1</td><td>↗</td></tr> <tr><td>17:</td><td>9.9</td><td>←</td></tr> <tr><td>18:</td><td>9.9</td><td>↓</td></tr> <tr><td>19:</td><td>8.8</td><td>←</td></tr> <tr><td>20:</td><td>9.6</td><td>←</td></tr> <tr><td colspan="2">Series</td><td>93.0</td></tr> <tr><td colspan="2">Total</td><td>0.0</td></tr> </table>	11:	10.2	↗	12:	9.4	↑	13:	9.8	↓	14:	*10.6	↗	15:	*10.6	↓	16:	10.1	↗	17:	9.9	←	18:	9.9	↓	19:	8.8	←	20:	9.6	←	Series		93.0	Total		0.0
11:	10.2	↗																																				
12:	9.4	↑																																				
13:	9.8	↓																																				
14:	*10.6	↗																																				
15:	*10.6	↓																																				
16:	10.1	↗																																				
17:	9.9	←																																				
18:	9.9	↓																																				
19:	8.8	←																																				
20:	9.6	←																																				
Series		93.0																																				
Total		0.0																																				
<table border="1" style="width:100%; border-collapse: collapse;"> <tr><td>21:</td><td>9.7</td><td>↓</td></tr> <tr><td>22:</td><td>9.5</td><td>↓</td></tr> <tr><td>23:</td><td>*10.6</td><td>→</td></tr> <tr><td colspan="2">Series</td><td>28.0</td></tr> <tr><td colspan="2">Total</td><td>0.0</td></tr> </table>	21:	9.7	↓	22:	9.5	↓	23:	*10.6	→	Series		28.0	Total		0.0	<table border="1" style="width:100%; border-collapse: collapse;"> <tr><td>1:</td><td>*10.4</td><td>→</td></tr> <tr><td>2:</td><td>9.3</td><td>↓</td></tr> <tr><td>3:</td><td>*10.7</td><td>↗</td></tr> <tr><td>4:</td><td>*10.5</td><td>↓</td></tr> <tr><td>5:</td><td>*10.4</td><td>↗</td></tr> <tr><td colspan="2">Series</td><td>49.0</td></tr> <tr><td colspan="2">Total</td><td>49.0</td></tr> </table>	1:	*10.4	→	2:	9.3	↓	3:	*10.7	↗	4:	*10.5	↓	5:	*10.4	↗	Series		49.0	Total		49.0	
21:	9.7	↓																																				
22:	9.5	↓																																				
23:	*10.6	→																																				
Series		28.0																																				
Total		0.0																																				
1:	*10.4	→																																				
2:	9.3	↓																																				
3:	*10.7	↗																																				
4:	*10.5	↓																																				
5:	*10.4	↗																																				
Series		49.0																																				
Total		49.0																																				

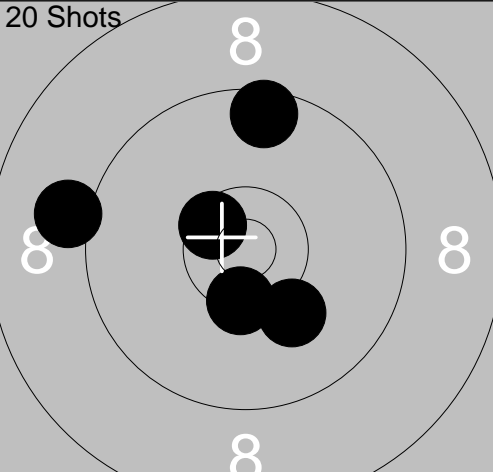
20 Shots 	20 Shots 	<table border="1" style="width:100%; border-collapse: collapse;"> <tr><td>6:</td><td>10.1</td><td>←</td></tr> <tr><td>7:</td><td>9.9</td><td>↑</td></tr> <tr><td>8:</td><td>9.5</td><td>↗</td></tr> <tr><td>9:</td><td>9.8</td><td>↗</td></tr> <tr><td>10:</td><td>*10.4</td><td>↓</td></tr> <tr><td colspan="2">Series</td><td>47.0</td></tr> <tr><td colspan="2">Total</td><td>96.0</td></tr> </table>	6:	10.1	←	7:	9.9	↑	8:	9.5	↗	9:	9.8	↗	10:	*10.4	↓	Series		47.0	Total		96.0
6:	10.1	←																					
7:	9.9	↑																					
8:	9.5	↗																					
9:	9.8	↗																					
10:	*10.4	↓																					
Series		47.0																					
Total		96.0																					
	<table border="1" style="width:100%; border-collapse: collapse;"> <tr><td>11:</td><td>*10.6</td><td>↓</td></tr> <tr><td>12:</td><td>*10.6</td><td>←</td></tr> <tr><td>13:</td><td>*10.5</td><td>↓</td></tr> <tr><td>14:</td><td>9.5</td><td>↗</td></tr> <tr><td>15:</td><td>*10.4</td><td>→</td></tr> <tr><td colspan="2">Series</td><td>49.0</td></tr> <tr><td colspan="2">Total</td><td>145.0</td></tr> </table>	11:	*10.6	↓	12:	*10.6	←	13:	*10.5	↓	14:	9.5	↗	15:	*10.4	→	Series		49.0	Total		145.0	
11:	*10.6	↓																					
12:	*10.6	←																					
13:	*10.5	↓																					
14:	9.5	↗																					
15:	*10.4	→																					
Series		49.0																					
Total		145.0																					

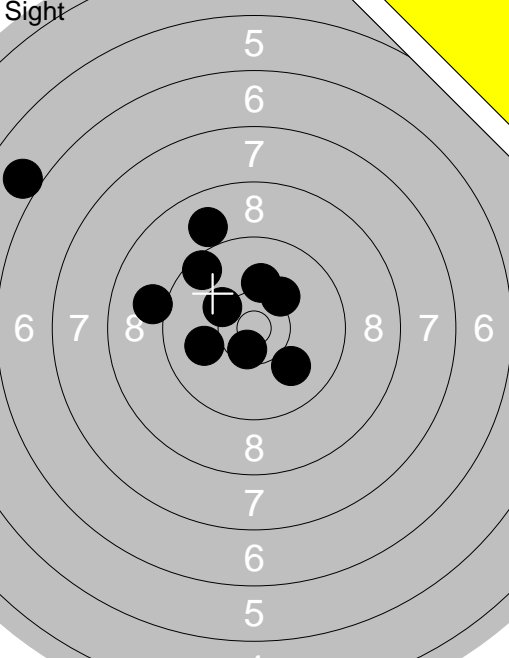
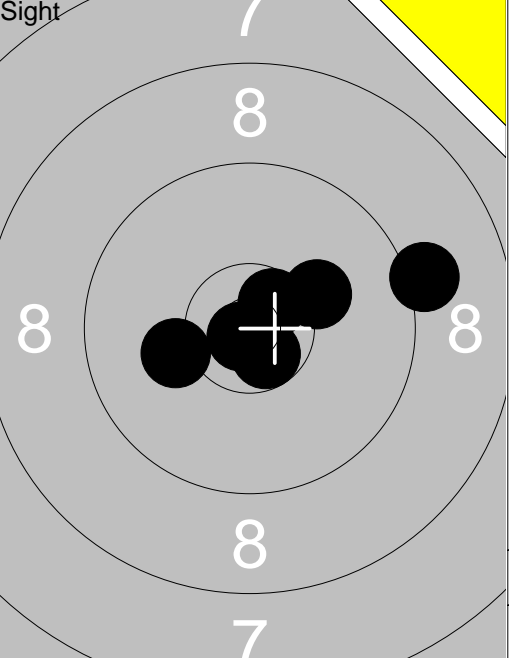
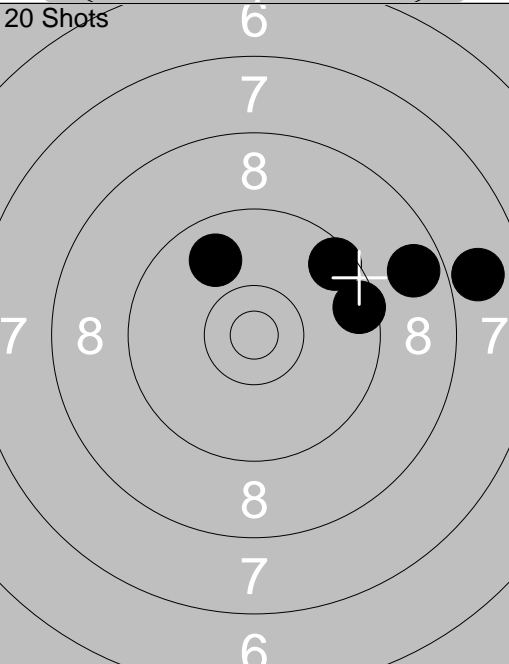
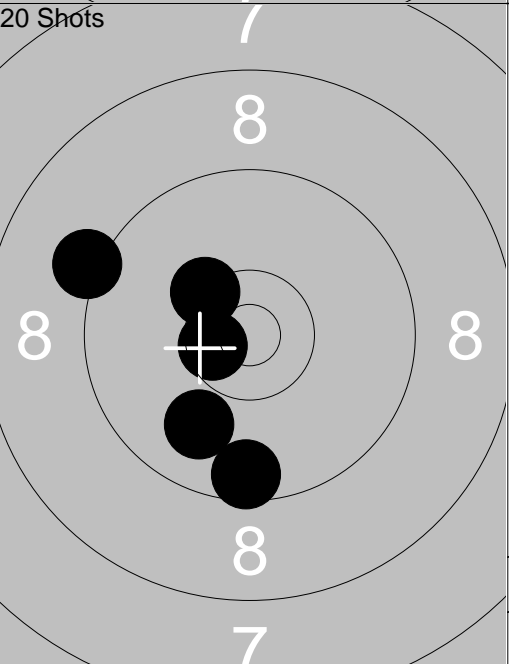
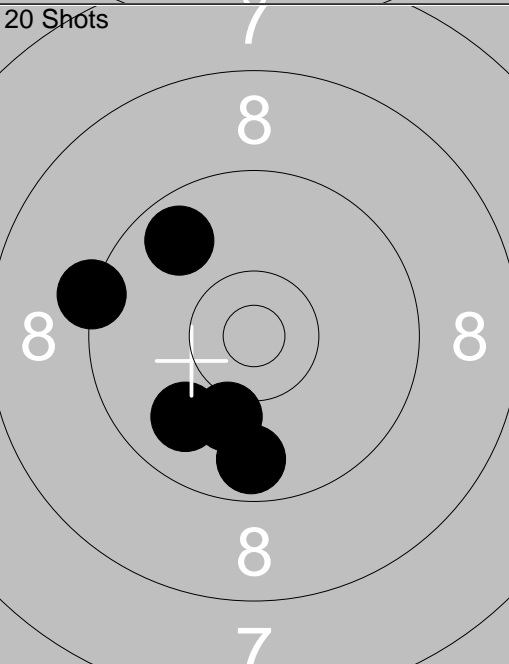
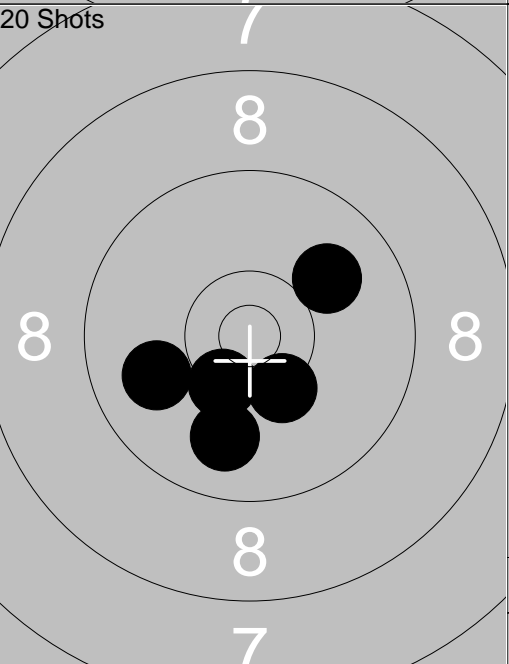
20 Shots 	<table border="1" style="width:100%; border-collapse: collapse;"> <tr><td>16:</td><td>*10.5</td><td>↗</td></tr> <tr><td>17:</td><td>10.1</td><td>↓</td></tr> <tr><td>18:</td><td>9.5</td><td>↑</td></tr> <tr><td>19:</td><td>9.1</td><td>←</td></tr> <tr><td>20:</td><td>*10.4</td><td>↓</td></tr> <tr><td colspan="2">Series</td><td>48.0</td></tr> <tr><td colspan="2">Total</td><td>193.0</td></tr> </table>	16:	*10.5	↗	17:	10.1	↓	18:	9.5	↑	19:	9.1	←	20:	*10.4	↓	Series		48.0	Total		193.0	
16:	*10.5	↗																					
17:	10.1	↓																					
18:	9.5	↑																					
19:	9.1	←																					
20:	*10.4	↓																					
Series		48.0																					
Total		193.0																					

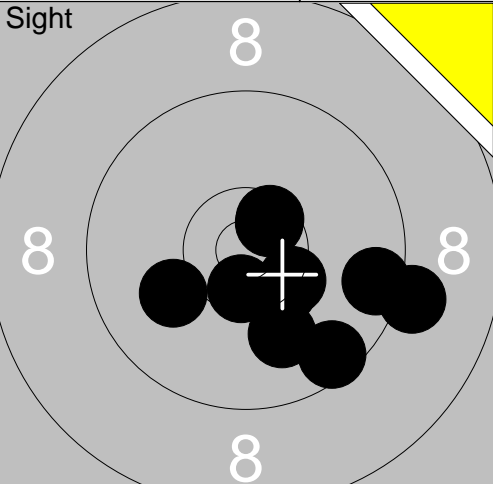
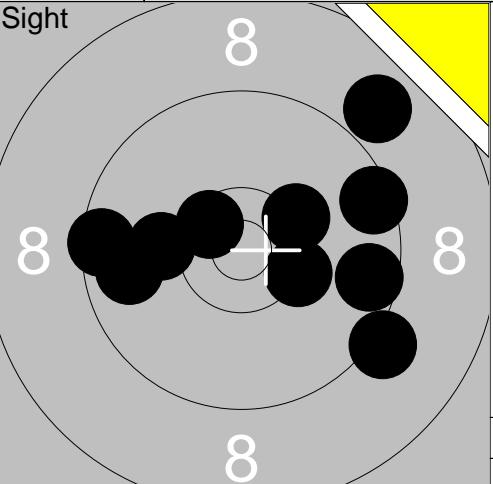
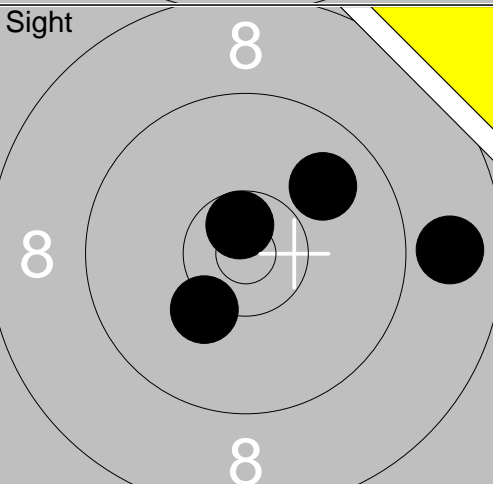
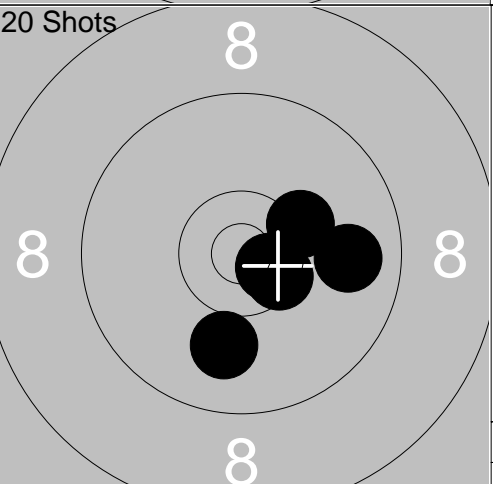
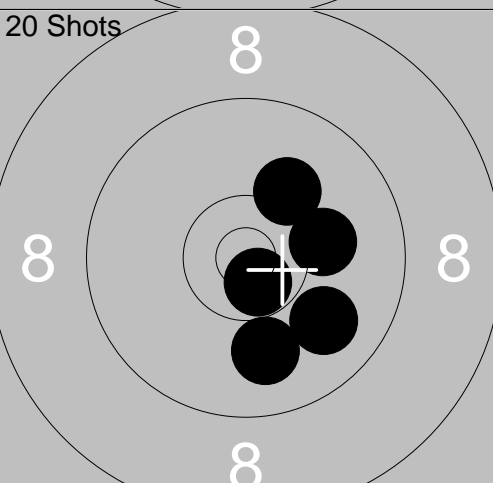
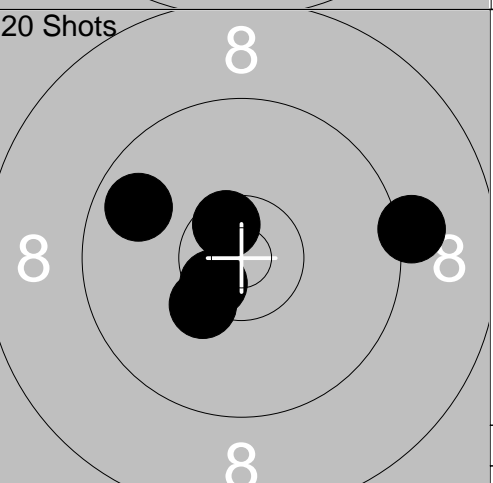
Relay	Lane	Johan Nilsson			
2	4				
50m	Ramselefors	Sen-L	Vb		
2013-07-09	Tavelträffen Korthäll 2013	Ramselefors SKF			
Sight		1: 6.0 ↙ 2: 10.1 ↑ 3: 9.5 ↘ 4: 10.0 ↙ 5: 10.3 ↘ 6: 8.9 ↑ 7: *10.6 ↘ 8: 9.1 ← 9: 10.2 ↗ 10: 10.0 ↘ Series 92.0 Total 0.0	Sight		11: 10.2 ↙ 12: *10.6 ↘ 13: *10.8 ↘ 14: *10.6 ↗ 15: 9.1 → 16: 10.2 ↗ Series 59.0 Total 0.0
20 Shots		1: 7.9 → 2: 8.7 → 3: 9.5 → 4: 9.8 ↑ 5: 9.5 ↗ Series 42.0 Total 42.0	20 Shots		6: 9.6 ↓ 7: 9.2 ↙ 8: *10.3 ↘ 9: 9.9 ↓ 10: *10.6 ↙ Series 47.0 Total 89.0
20 Shots		11: 9.7 ↘ 12: 9.3 ← 13: 9.7 ↓ 14: 9.9 ↙ 15: 10.1 ↓ Series 46.0 Total 135.0	20 Shots		16: 9.9 ↙ 17: *10.4 ↘ 18: 9.9 ↓ 19: 10.0 ↗ 20: *10.3 ↘ Series 48.0 Total 183.0

Relay	Lane	Marlene Forsell		
50m		Ramselefors	Sen-L Vb	
2013-07-09		Tavelträffen Korthäll 2013	Ramselefors SKF	
Sight		1: 9.6 ↘ 2: 9.6 → 3: 9.2 → 4: *10.5 ↗ 5: *10.4 ↘ 6: *10.4 ↘ 7: *10.6 ↗ 8: 10.0 ↘ 9: 10.1 ← 10: *10.5 ↓ Series 97.0 Total 0.0	Sight  11: 9.2 ↘ 12: *10.3 → 13: 8.9 ↗ 14: *10.3 ↗ 15: 9.5 → 16: 9.6 → 17: 10.1 ← 18: 9.8 ← 19: *10.5 ↗ 20: 9.5 ← Series 93.0 Total 0.0	
Sight		21: 10.2 ↙ 22: 9.9 ↗ 23: 8.8 → 24: *10.7 ↑ Series 37.0 Total 0.0	20 Shots 	1: *10.6 ↘ 2: 9.8 → 3: *10.5 ↘ 4: 10.0 ↓ 5: 10.3 ↗ Series 49.0 Total 49.0
20 Shots		6: 10.0 ↓ 7: 10.1 ↗ 8: 10.1 → 9: *10.7 ↘ 10: 9.9 ↘ Series 49.0 Total 98.0	20 Shots 	11: *10.6 ↙ 12: 9.2 → 13: *10.3 ↙ 14: 9.8 ↙ 15: *10.6 ↗ Series 48.0 Total 146.0
20 Shots		16: 9.9 ↓ 17: 9.9 ↘ 18: *10.4 ↑ 19: 9.8 ↓ 20: 9.2 ← Series 46.0 Total 192.0		

Relay 2	Lane 6	Håkan Lidman	
-------------------	------------------	---------------------	--

50m	Skellefteå	Vet-L	Vb
-----	------------	-------	----

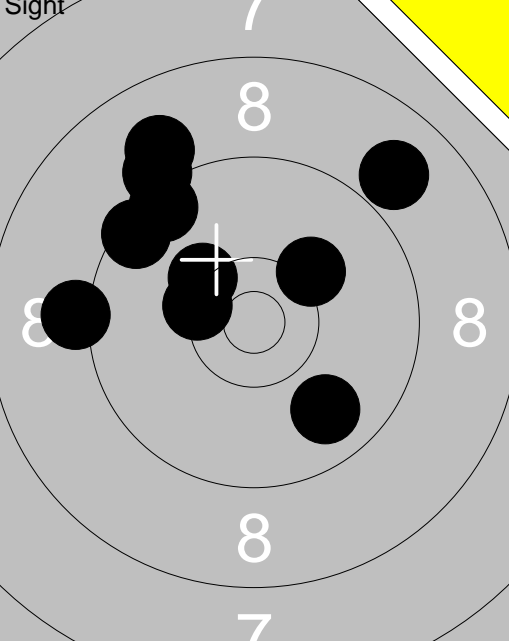
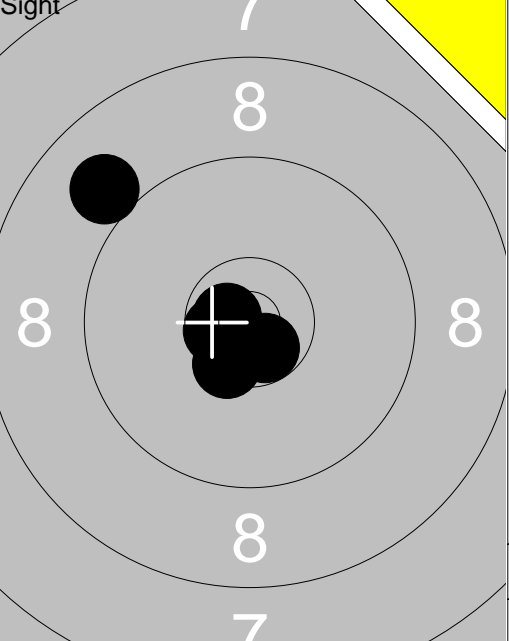

2013-07-09	Tavelträffen Korthåll 2013	Ramselefors SKF
------------	----------------------------	-----------------

<p>Sight</p>	<p>1: 8.9 ↑ 2: 10.2 ↗ 3: 8.8 → 4: 8.3 ↗ 5: 8.8 → 6: 9.7 → 7: 9.4 ↖ 8: 10.2 ↘ 9: 10.2 ↖ 10: 10.2 ↙</p> <p>Series 90.0 Total 0.0</p>	<p>Sight</p>	<p>11: 9.9 ← 12: 10.0 ↖ 13: 9.4 → 14: 9.2 ← 15: *10.5 ↘ 16: 9.8 ↑ 17: 9.0 ↖ 18: 9.9 ↘ 19: 9.3 → 20: 10.3 ↖</p> <p>Series 93.0 Total 0.0</p>
<p>20 Shots</p>	<p>1: 9.1 ↗ 2: *10.4 ↘ 3: 9.7 ↘ 4: 9.5 ↖ 5: *10.4 →</p> <p>Series 47.0 Total 47.0</p>	<p>20 Shots</p>	<p>6: 9.8 ↖ 7: 9.8 → 8: *10.3 ↗ 9: 9.7 → 10: *10.7 ↖</p> <p>Series 47.0 Total 94.0</p>
<p>20 Shots</p>	<p>11: 9.8 → 12: 8.8 ↑ 13: 9.0 ↖ 14: 8.9 ↘ 15: 9.7 ↗</p> <p>Series 43.0 Total 137.0</p>	<p>20 Shots</p>	<p>16: 9.4 ↖ 17: *10.5 ↘ 18: 9.6 ← 19: 10.1 ↗ 20: *10.6 ↖</p> <p>Series 48.0 Total 185.0</p>

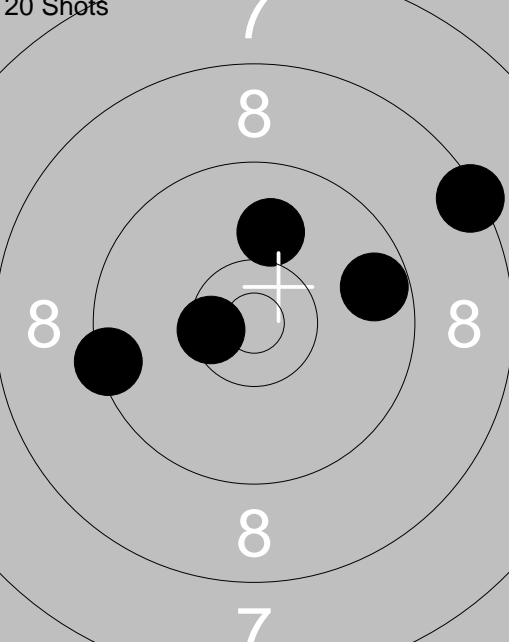
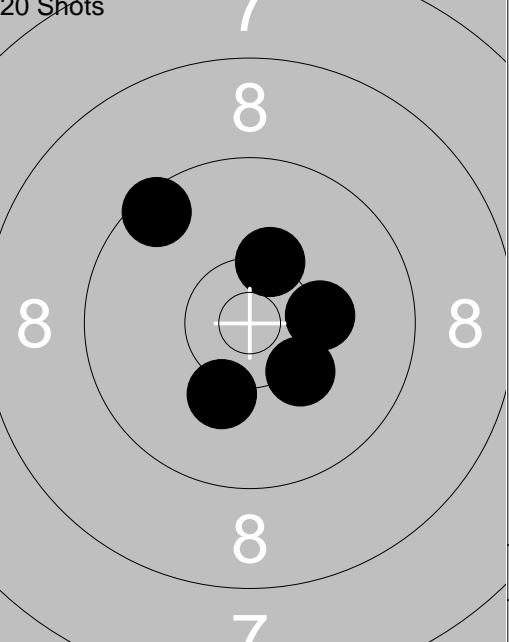
<p>Sight</p> 	<p>1: 9.5 ↖ 2: *10.4 ↖ 3: 9.0 ↗ 4: 10.2 ↗ 5: 9.5 ↗ 6: 10.3 ↖ 7: 9.8 ↘ 8: 9.2 ← 9: 8.9 ↗ 10: 9.2 ↖</p> <p>Series 92.0 Total 0.0</p>	<p>Sight</p> 	<p>11: *10.7 ↖ 12: *10.6 ↖ 13: 9.0 ↖ 14: *10.5 ↘ 15: *10.7 ↘</p> <p>Series 49.0 Total 0.0</p>
---	---	---	---

<p>20 Shots</p> 	<p>1: *10.5 ↖ 2: 8.4 ↗ 3: 9.7 → 4: 9.4 ← 5: 10.0 ↑</p> <p>Series 46.0 Total 46.0</p>	<p>20 Shots</p> 	<p>6: 9.5 ↖ 7: 10.3 ↘ 8: *10.3 ↗ 9: 10.2 ↘ 10: 10.2 →</p> <p>Series 49.0 Total 95.0</p>
---	--	---	---

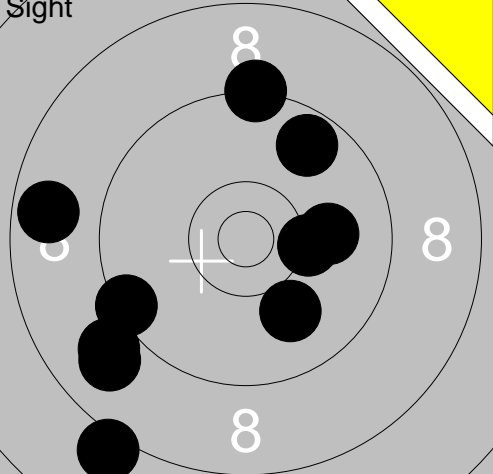
<p>20 Shots</p> 	<p>11: 9.5 → 12: 9.9 ↑ 13: 9.3 ↗ 14: 9.2 ↖ 15: 10.1 ↑</p> <p>Series 46.0 Total 141.0</p>	<p>20 Shots</p> 	<p>16: *10.5 ↖ 17: *10.6 ↗ 18: 9.5 ← 19: *10.6 ↘ 20: 8.3 ←</p> <p>Series 47.0 Total 188.0</p>
--	--	--	---

<p>Sight</p> 	<p>1: 8.7 ← 2: 8.9 ↙ 3: 9.0 ↙ 4: 8.1 ↘ 5: 10.0 ↘ 6: 9.3 ↑ 7: 9.4 ← 8: 9.7 ↗ 9: 10.2 → 10: 10.0 →</p> <p>Series 90.0 Total 0.0</p>	<p>Sight</p> 	<p>11: *10.5 → 12: 10.2 ↓ 13: *10.8 ← 14: 9.9 ↗ 15: 9.5 ↘ 16: 9.5 ↗ 17: 9.1 ↓ 18: 7.7 → 19: 9.8 ↓ 20: 8.3 ↓</p> <p>Series 90.0 Total 0.0</p>
--	---	--	--

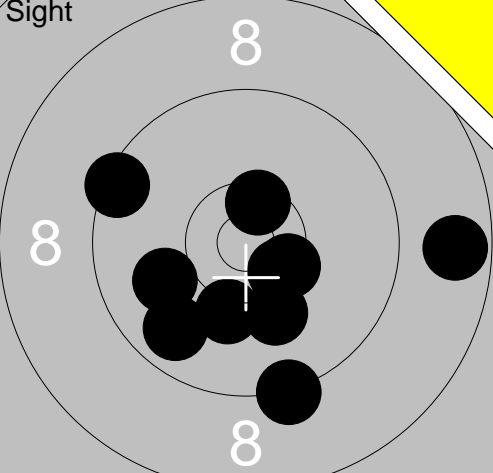
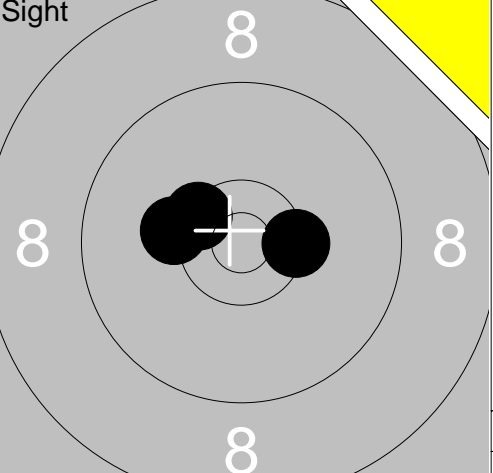
<p>Sight</p> 	<p>21: 8.7 → 22: 9.4 ↗ 23: 10.1 ↘ 24: *10.5 ↗ 25: 9.8 ↘ 26: *10.5 ↘ 27: 9.3 ↘ 28: 10.0 ← 29: *10.4 ↘ 30: 10.2 ↓</p> <p>Series 95.0 Total 0.0</p>	<p>Sight</p> 	<p>31: 10.2 ← 32: *10.4 → 33: *10.4 ↗</p> <p>Series 30.0 Total 0.0</p>
---	--	---	--

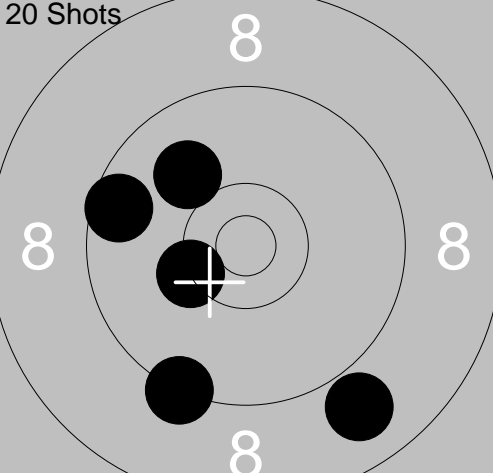
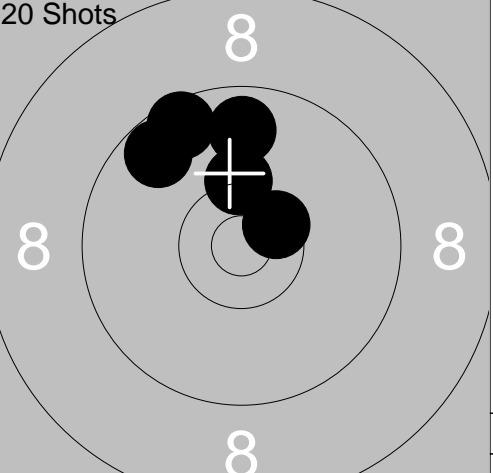
<p>20 Shots</p> 	<p>1: 9.3 ↓ 2: 8.9 ↓ 3: *10.3 ← 4: 9.6 ← 5: 10.0 ↗</p> <p>Series 46.0 Total 46.0</p>	<p>20 Shots</p> 	<p>6: 9.8 ↑ 7: 10.3 ↑ 8: 9.6 ↗ 9: *10.5 ↗ 10: 9.7 ↗</p> <p>Series 47.0 Total 93.0</p>
---	--	---	---

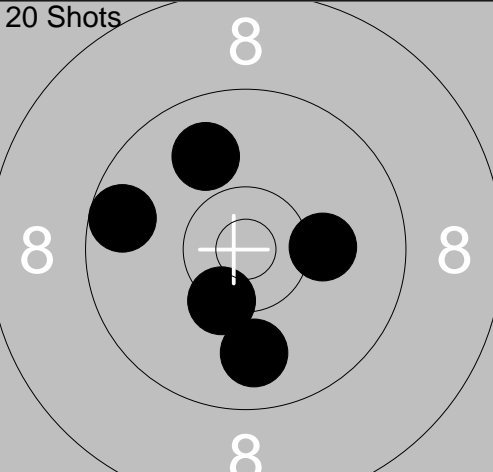
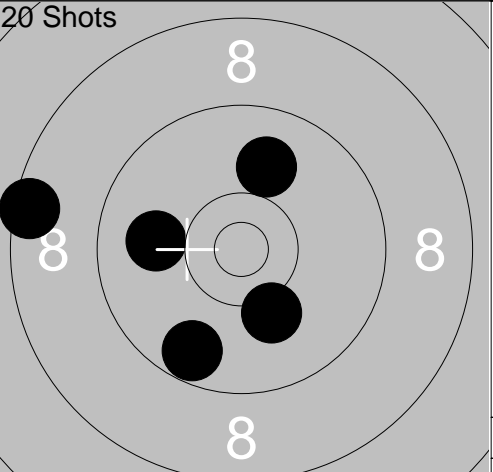
<p>20 Shots</p> 	<p>11: 10.2 → 12: 9.9 ↗ 13: *10.4 ↘ 14: 9.6 ← 15: 9.9 ↓</p> <p>Series 47.0 Total 140.0</p>	<p>20 Shots</p> 	<p>16: 10.0 ↗ 17: 10.0 ← 18: 9.7 ↘ 19: 10.1 ↘ 20: 8.5 ←</p> <p>Series 47.0 Total 187.0</p>
---	--	---	--

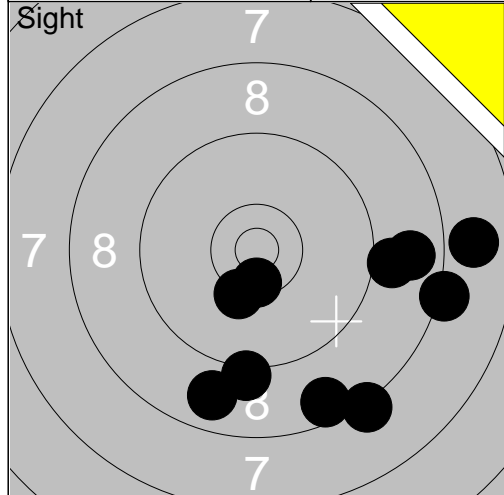

1:	7.9	→
2:	9.2	↓
3:	9.0	→
4:	8.2	↘
5:	8.2	→
6:	8.8	→
7:	8.6	↓
8:	8.8	↓
9:	10.3	↓
10:	*10.5	↓
Series		85.0
Total		0.0

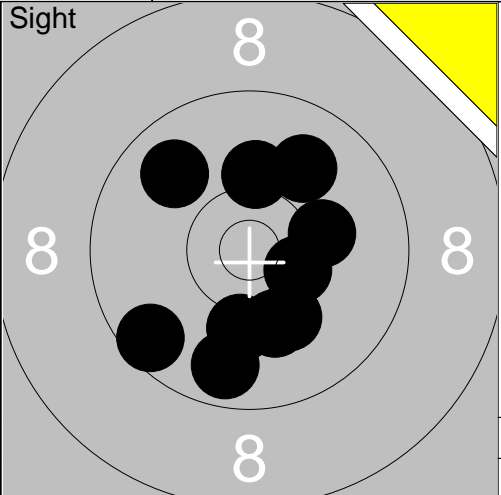

11:	9.7	↓
12:	10.1	↓
13:	*10.4	→
14:	10.1	↘
15:	10.2	↑
16:	10.1	↘
17:	9.8	↗
18:	9.9	↗
19:	10.2	→
20:	9.6	↙
Series		96.0
Total		0.0

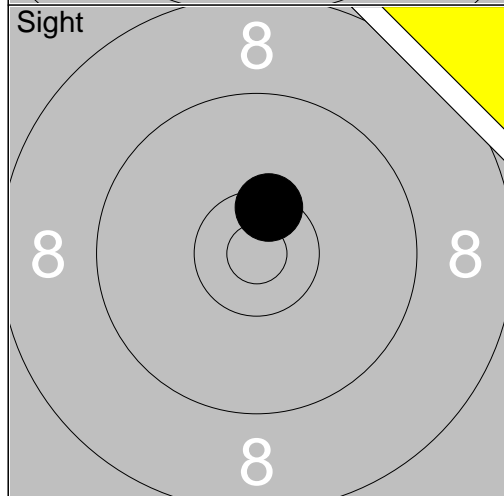

21:	*10.5	↑
Series		10.0
Total		0.0

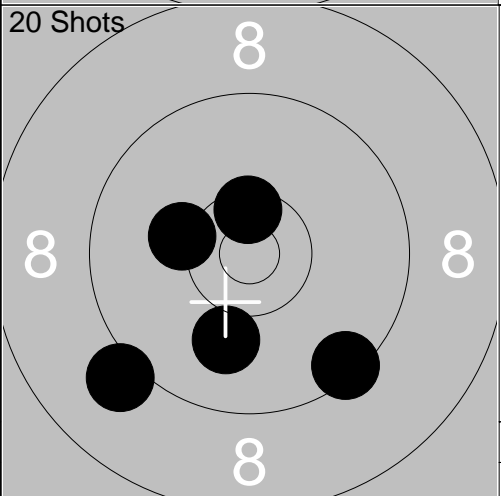

1:	9.1	↙
2:	10.0	↓
3:	10.2	←
4:	9.4	↘
5:	*10.5	↑
Series		48.0
Total		48.0

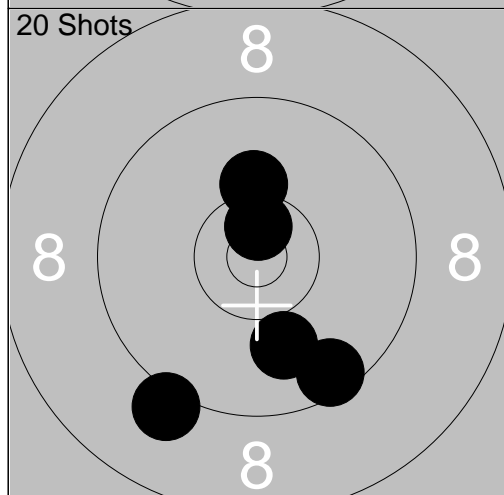

6:	10.2	↑
7:	9.5	↘
8:	9.1	↘
9:	*10.6	↑
10:	10.0	↓
Series		48.0
Total		96.0

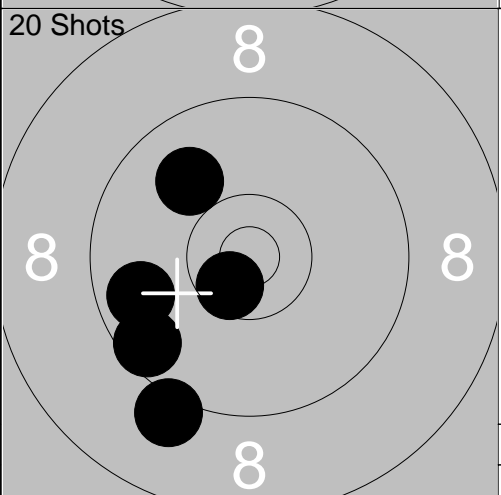

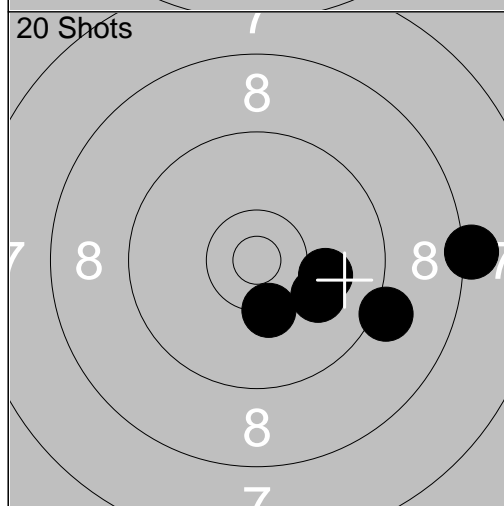

11:	10.0	↖
12:	*10.6	↓
13:	9.6	↙
14:	9.1	↘
15:	9.8	←
Series		47.0
Total		143.0

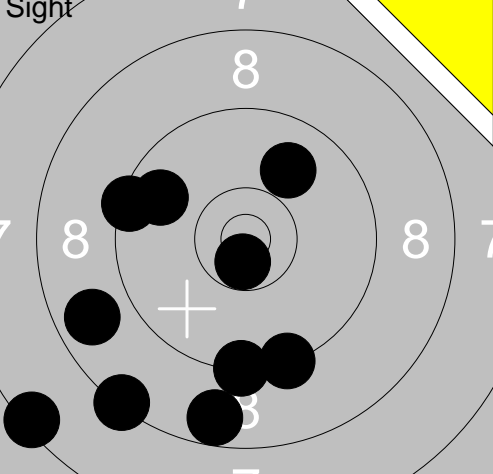
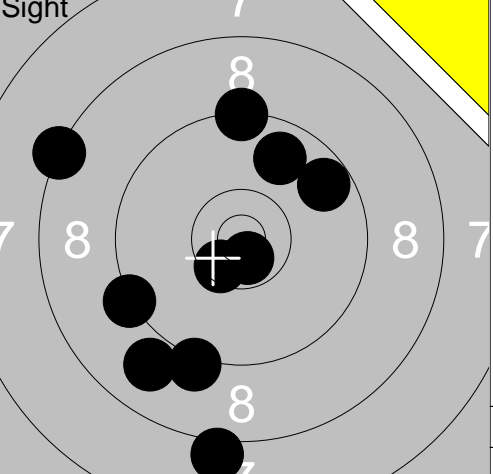

16:	*10.3	↓
17:	10.0	↘
18:	8.2	→
19:	10.1	→
20:	9.2	↘
Series		47.0
Total		190.0

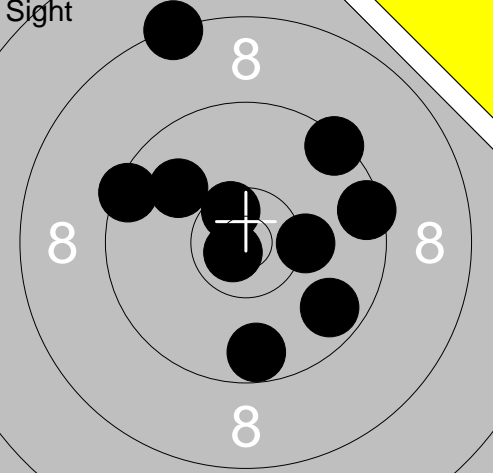
	1: 8.4 ↙		11: 9.7 ↗
	2: 7.4 ↙		12: 8.1 ↓
	3: 8.7 ↓		13: *10.5 ↙
4: 8.8 ↙	14: 9.3 ↙	15: 8.3 ↙	16: 9.3 ↑
5: 9.4 ↙	17: 9.2 ↓	18: 8.9 ↙	19: 9.8 ↗
6: 9.3 ↓	20: *10.7 ↓	Series	89.0
7: 9.7 ↗	Total	0.0	0.0
8: *10.7 ↓			
9: 9.3 ↓			
10: 9.9 ↗			

	21: 9.4 ↗		31: 8.9 ↑
	22: 9.9 ↗		32: 6.3 ↗
	23: 10.2 →		Series
24: 9.7 ↓	Total	0.0	0.0
25: *10.8 ↙			
26: 9.5 ↙			
27: *10.5 ↗			
28: 8.3 ↗			
29: 9.5 →			
30: 9.7 ↘			

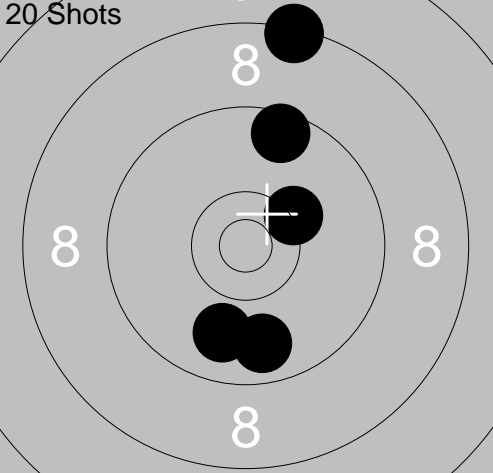
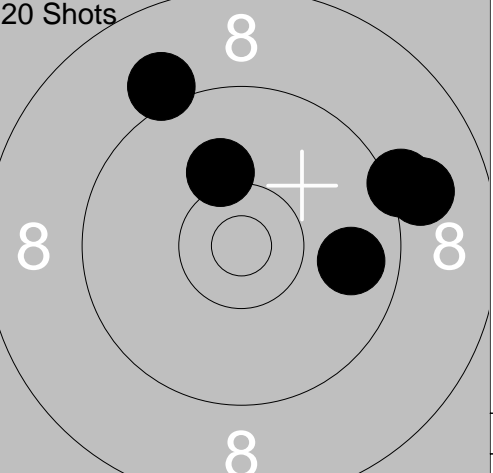
	1: 9.9 ↓		6: 10.2 ↗
	2: 9.8 ↓		7: 9.8 →
	3: 9.6 ↑		8: 9.0 →
4: 8.4 ↑	9: 9.2 ↗	Series	46.0
5: 10.3 ↗	10: 9.1 ↗	Total	91.0
Series	45.0		
Total	45.0		

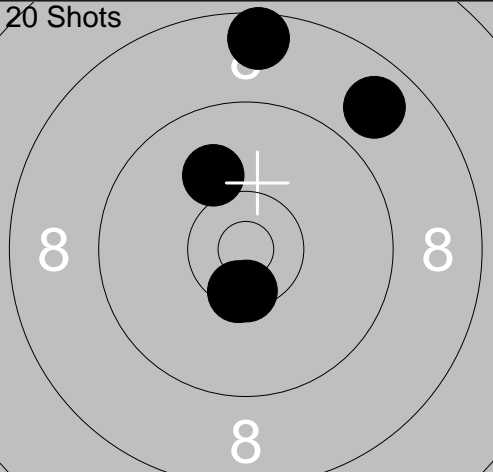
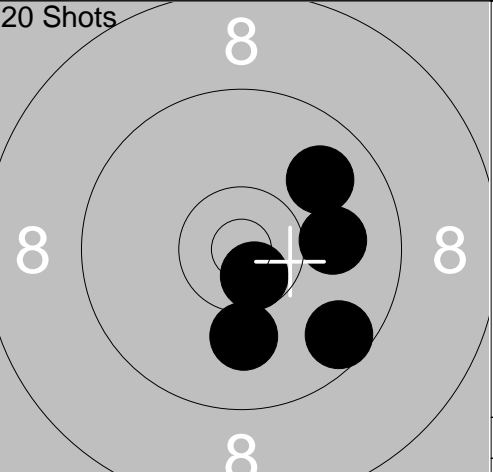
	11: 8.6 ↑		16: 10.0 →
	12: 8.8 ↗		17: *10.6 ↓
	13: *10.5 ↓		18: 10.1 ↓
14: *10.5 ↓	19: 9.6 ↘	Series	48.0
15: 10.0 ↗	20: 9.9 ↗	Total	185.0
Series	46.0		
Total	137.0		

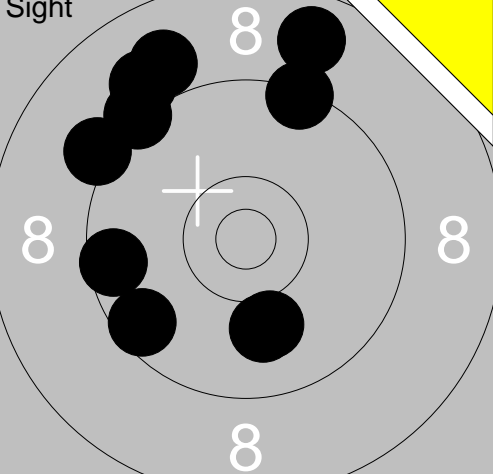
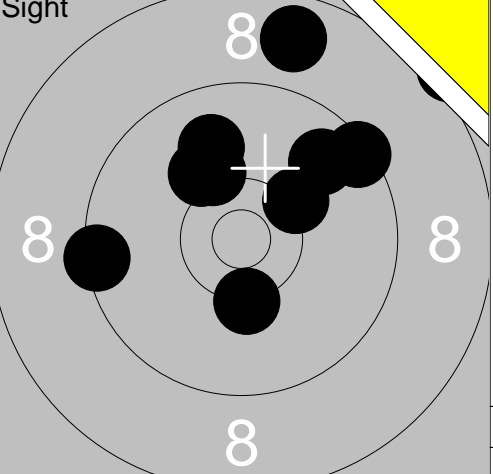
<p>Sight</p> 	<table border="1" style="width:100%; border-collapse: collapse;"> <tr><td>1:</td><td>9.0</td><td>↗</td></tr> <tr><td>2:</td><td>9.0</td><td>↗</td></tr> <tr><td>3:</td><td>9.6</td><td>↘</td></tr> <tr><td>4:</td><td>9.3</td><td>↗</td></tr> <tr><td>5:</td><td>9.2</td><td>↗</td></tr> <tr><td>6:</td><td>10.0</td><td>↘</td></tr> <tr><td>7:</td><td>9.6</td><td>←</td></tr> <tr><td>8:</td><td>8.8</td><td>↗</td></tr> <tr><td>9:</td><td>9.4</td><td>↗</td></tr> <tr><td>10:</td><td>10.0</td><td>↘</td></tr> <tr><td colspan="2">Series</td><td>91.0</td></tr> <tr><td colspan="2">Total</td><td>0.0</td></tr> </table>	1:	9.0	↗	2:	9.0	↗	3:	9.6	↘	4:	9.3	↗	5:	9.2	↗	6:	10.0	↘	7:	9.6	←	8:	8.8	↗	9:	9.4	↗	10:	10.0	↘	Series		91.0	Total		0.0	<p>Sight</p> 	<table border="1" style="width:100%; border-collapse: collapse;"> <tr><td>11:</td><td>9.4</td><td>←</td></tr> <tr><td>12:</td><td>9.8</td><td>↗</td></tr> <tr><td>13:</td><td>*10.3</td><td>↘</td></tr> <tr><td>14:</td><td>9.9</td><td>↗</td></tr> <tr><td>15:</td><td>8.1</td><td>↗</td></tr> <tr><td>16:</td><td>10.1</td><td>↖</td></tr> <tr><td>17:</td><td>10.2</td><td>↗</td></tr> <tr><td>18:</td><td>9.4</td><td>↗</td></tr> <tr><td>19:</td><td>10.2</td><td>↖</td></tr> <tr><td>20:</td><td>8.8</td><td>↗</td></tr> <tr><td colspan="2">Series</td><td>92.0</td></tr> <tr><td colspan="2">Total</td><td>0.0</td></tr> </table>	11:	9.4	←	12:	9.8	↗	13:	*10.3	↘	14:	9.9	↗	15:	8.1	↗	16:	10.1	↖	17:	10.2	↗	18:	9.4	↗	19:	10.2	↖	20:	8.8	↗	Series		92.0	Total		0.0
1:	9.0	↗																																																																									
2:	9.0	↗																																																																									
3:	9.6	↘																																																																									
4:	9.3	↗																																																																									
5:	9.2	↗																																																																									
6:	10.0	↘																																																																									
7:	9.6	←																																																																									
8:	8.8	↗																																																																									
9:	9.4	↗																																																																									
10:	10.0	↘																																																																									
Series		91.0																																																																									
Total		0.0																																																																									
11:	9.4	←																																																																									
12:	9.8	↗																																																																									
13:	*10.3	↘																																																																									
14:	9.9	↗																																																																									
15:	8.1	↗																																																																									
16:	10.1	↖																																																																									
17:	10.2	↗																																																																									
18:	9.4	↗																																																																									
19:	10.2	↖																																																																									
20:	8.8	↗																																																																									
Series		92.0																																																																									
Total		0.0																																																																									

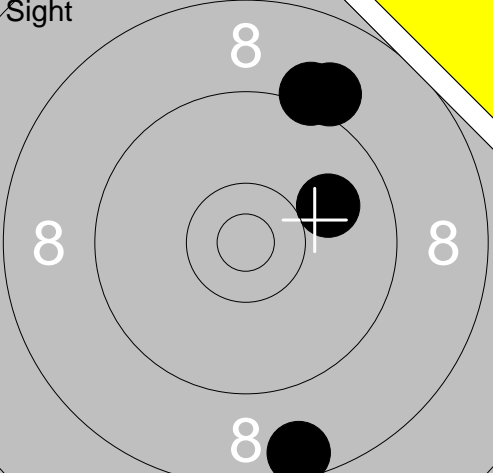
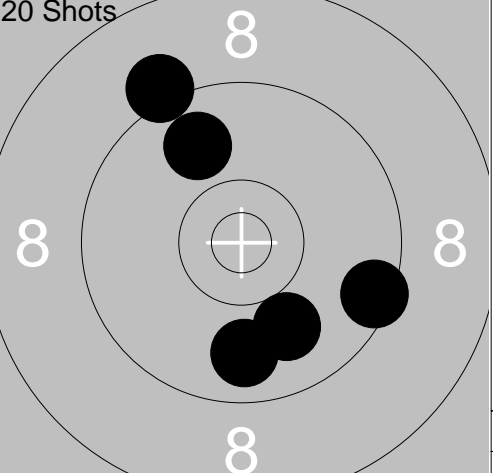
<p>Sight</p> 	<table border="1" style="width:100%; border-collapse: collapse;"> <tr><td>21:</td><td>9.1</td><td>↗</td></tr> <tr><td>22:</td><td>9.2</td><td>↗</td></tr> <tr><td>23:</td><td>8.6</td><td>↘</td></tr> <tr><td>24:</td><td>10.0</td><td>↗</td></tr> <tr><td colspan="2">Series</td><td>36.0</td></tr> <tr><td colspan="2">Total</td><td>0.0</td></tr> </table>	21:	9.1	↗	22:	9.2	↗	23:	8.6	↘	24:	10.0	↗	Series		36.0	Total		0.0	<p>20 Shots</p> 	<table border="1" style="width:100%; border-collapse: collapse;"> <tr><td>1:</td><td>9.8</td><td>↘</td></tr> <tr><td>2:</td><td>9.2</td><td>↗</td></tr> <tr><td>3:</td><td>9.5</td><td>↘</td></tr> <tr><td>4:</td><td>10.0</td><td>↘</td></tr> <tr><td>5:</td><td>9.9</td><td>↗</td></tr> <tr><td colspan="2">Series</td><td>46.0</td></tr> <tr><td colspan="2">Total</td><td>46.0</td></tr> </table>	1:	9.8	↘	2:	9.2	↗	3:	9.5	↘	4:	10.0	↘	5:	9.9	↗	Series		46.0	Total		46.0
21:	9.1	↗																																								
22:	9.2	↗																																								
23:	8.6	↘																																								
24:	10.0	↗																																								
Series		36.0																																								
Total		0.0																																								
1:	9.8	↘																																								
2:	9.2	↗																																								
3:	9.5	↘																																								
4:	10.0	↘																																								
5:	9.9	↗																																								
Series		46.0																																								
Total		46.0																																								

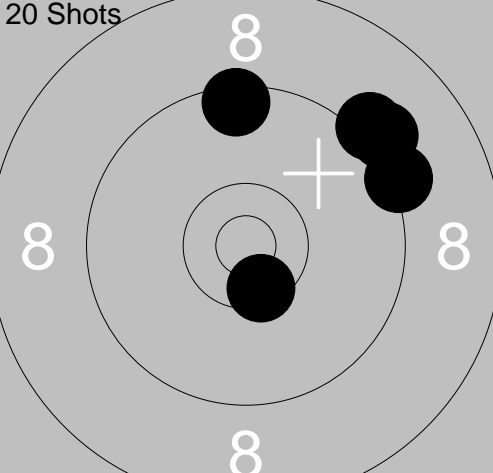
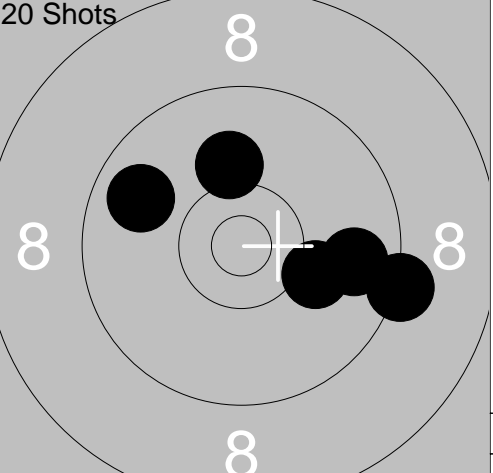
<p>20 Shots</p> 	<table border="1" style="width:100%; border-collapse: collapse;"> <tr><td>6:</td><td>9.1</td><td>↗</td></tr> <tr><td>7:</td><td>9.5</td><td>↗</td></tr> <tr><td>8:</td><td>9.2</td><td>↗</td></tr> <tr><td>9:</td><td>9.2</td><td>↗</td></tr> <tr><td>10:</td><td>*10.5</td><td>↘</td></tr> <tr><td colspan="2">Series</td><td>46.0</td></tr> <tr><td colspan="2">Total</td><td>92.0</td></tr> </table>	6:	9.1	↗	7:	9.5	↗	8:	9.2	↗	9:	9.2	↗	10:	*10.5	↘	Series		46.0	Total		92.0	<p>20 Shots</p> 	<table border="1" style="width:100%; border-collapse: collapse;"> <tr><td>11:</td><td>10.1</td><td>↗</td></tr> <tr><td>12:</td><td>9.8</td><td>↖</td></tr> <tr><td>13:</td><td>9.3</td><td>↘</td></tr> <tr><td>14:</td><td>10.1</td><td>↘</td></tr> <tr><td>15:</td><td>9.8</td><td>↘</td></tr> <tr><td colspan="2">Series</td><td>47.0</td></tr> <tr><td colspan="2">Total</td><td>139.0</td></tr> </table>	11:	10.1	↗	12:	9.8	↖	13:	9.3	↘	14:	10.1	↘	15:	9.8	↘	Series		47.0	Total		139.0
6:	9.1	↗																																											
7:	9.5	↗																																											
8:	9.2	↗																																											
9:	9.2	↗																																											
10:	*10.5	↘																																											
Series		46.0																																											
Total		92.0																																											
11:	10.1	↗																																											
12:	9.8	↖																																											
13:	9.3	↘																																											
14:	10.1	↘																																											
15:	9.8	↘																																											
Series		47.0																																											
Total		139.0																																											

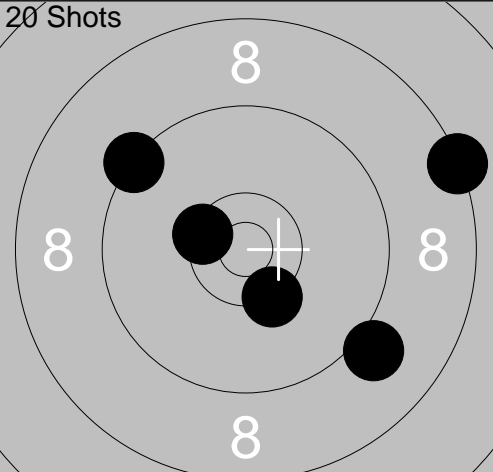
<p>20 Shots</p> 	<table border="1" style="width:100%; border-collapse: collapse;"> <tr><td>16:</td><td>*10.3</td><td>↘</td></tr> <tr><td>17:</td><td>*10.4</td><td>↖</td></tr> <tr><td>18:</td><td>9.1</td><td>↘</td></tr> <tr><td>19:</td><td>9.3</td><td>↗</td></tr> <tr><td>20:</td><td>8.3</td><td>↗</td></tr> <tr><td colspan="2">Series</td><td>46.0</td></tr> <tr><td colspan="2">Total</td><td>185.0</td></tr> </table>	16:	*10.3	↘	17:	*10.4	↖	18:	9.1	↘	19:	9.3	↗	20:	8.3	↗	Series		46.0	Total		185.0		
16:	*10.3	↘																						
17:	*10.4	↖																						
18:	9.1	↘																						
19:	9.3	↗																						
20:	8.3	↗																						
Series		46.0																						
Total		185.0																						

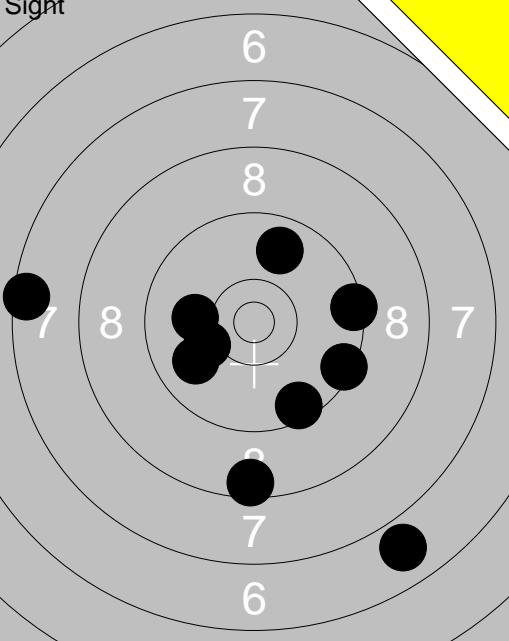
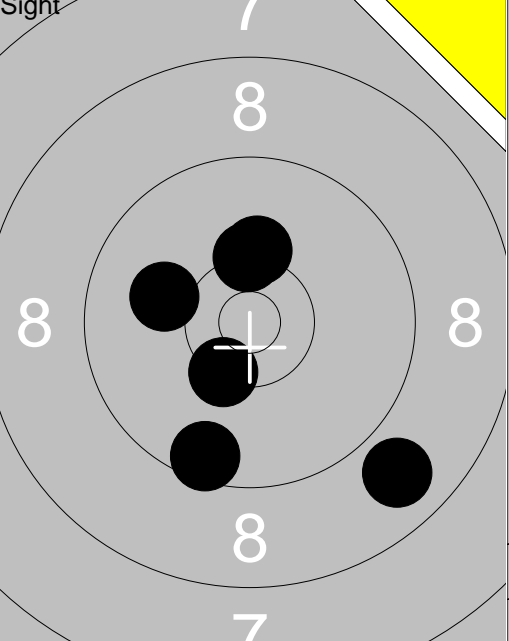
 <p>Sight</p>	<p>1: 9.5 ↘ 2: 10.2 ↙ 3: 9.9 ↙ 4: 8.5 ↓ 5: 9.8 ↗ 6: 9.4 → 7: 6.9 ↓ 8: 9.4 → 9: 7.5 ← 10: 10.1 ←</p> <p>Series 86.0 Total 0.0</p>	 <p>Sight</p>	<p>11: 8.8 ↘ 12: 9.5 ↓ 13: 10.2 ↑ 14: 10.1 ↙ 15: *10.3 ↑ 16: *10.4 ↙</p> <p>Series 57.0 Total 0.0</p>
---	--	---	---

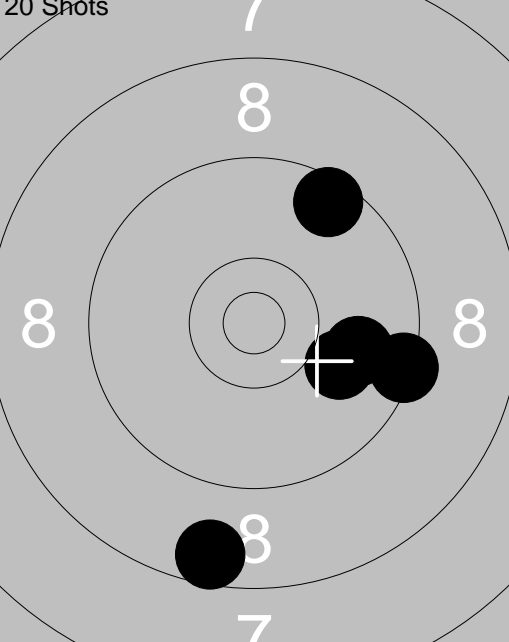
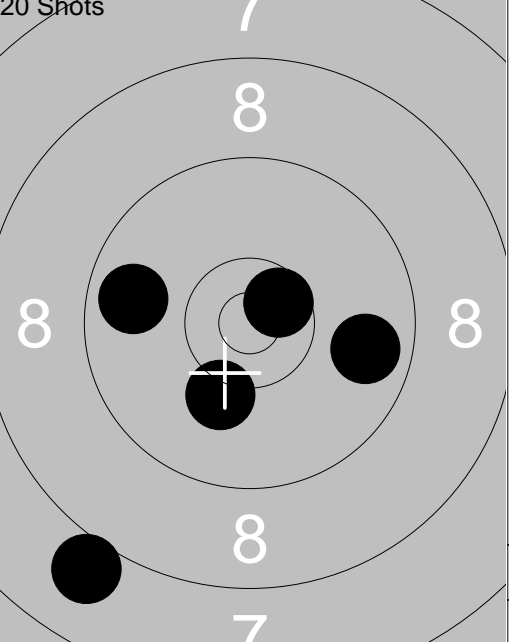
 <p>20 Shots</p>	<p>1: 10.0 → 2: 8.6 ↓ 3: 9.4 → 4: 9.9 → 5: 9.5 ↗</p> <p>Series 45.0 Total 45.0</p>	 <p>20 Shots</p>	<p>6: 8.0 ↘ 7: 9.8 → 8: 9.8 ← 9: 10.2 ↓ 10: *10.6 ↗</p> <p>Series 46.0 Total 91.0</p>
---	--	---	---

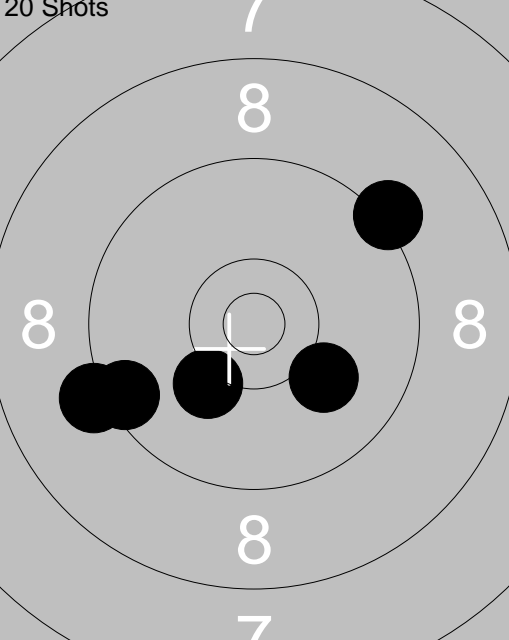
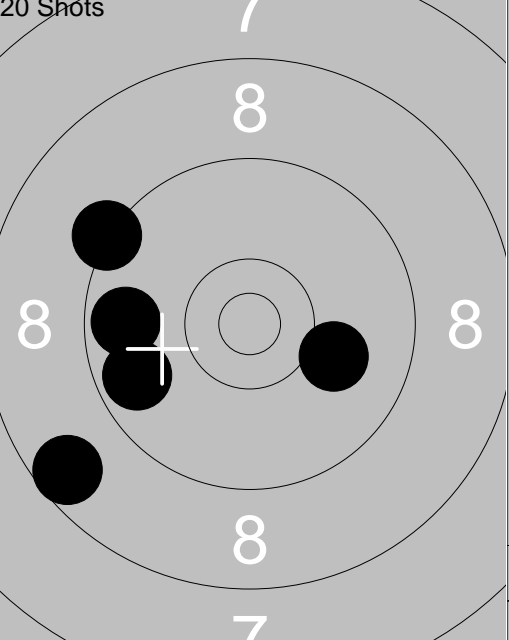
 <p>20 Shots</p>	<p>11: 9.2 ↗ 12: 10.1 ↘ 13: 10.2 ↓ 14: 9.5 ↙ 15: 9.2 ↙</p> <p>Series 47.0 Total 138.0</p>	 <p>20 Shots</p>	<p>16: 9.7 ← 17: 10.0 → 18: 9.3 ↙ 19: 9.7 ↙ 20: 8.6 ↙</p> <p>Series 45.0 Total 183.0</p>
--	---	--	--

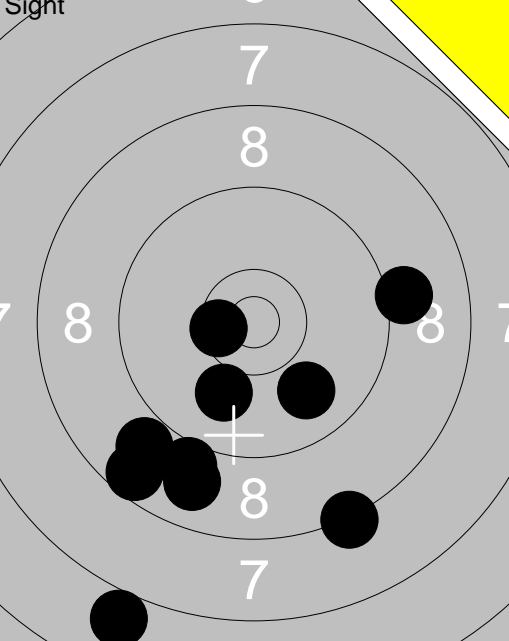
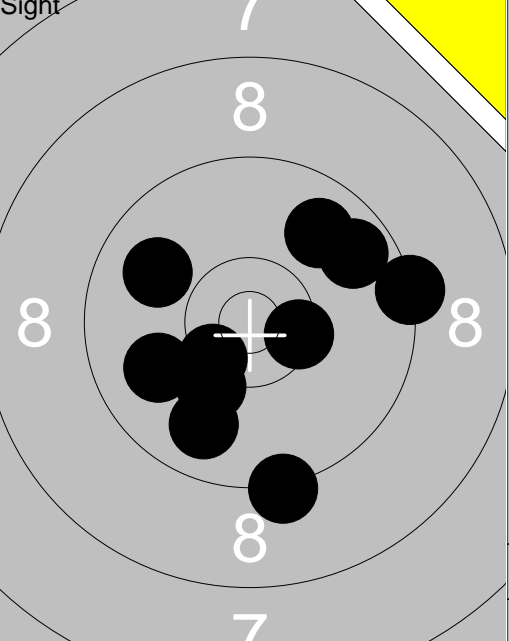
 <p>Sight</p>	<p>1: 7.0 ↓ 2: 8.6 ↓ 3: *10.5 ← 4: 8.3 ↓ 5: 10.0 ↓ 6: 9.1 → 7: 8.9 ↓ 8: 9.0 ↓ 9: 8.9 ↓ 10: 9.9 ↓</p> <p>Series 86.0 Total 0.0</p>	 <p>Sight</p>	<p>11: 9.9 ← 12: 9.8 ↓ 13: 9.9 ← 14: 9.7 ↗ 15: 9.8 ↗ 16: *10.4 ↙ 17: 10.2 ↓ 18: *10.4 → 19: 9.3 ↓ 20: 9.3 →</p> <p>Series 93.0 Total 0.0</p>
---	---	---	--

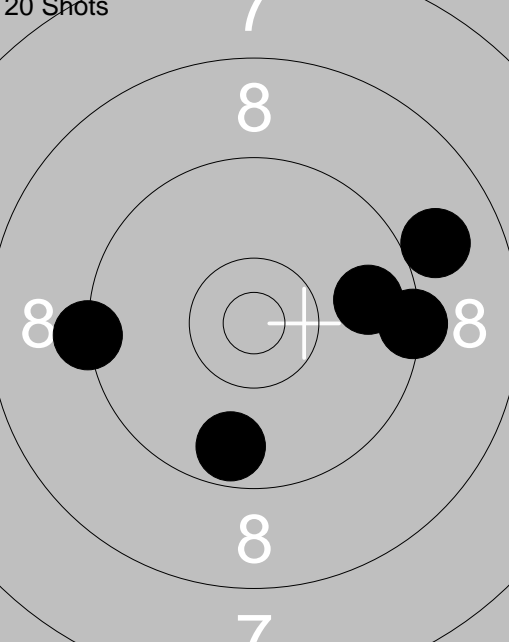
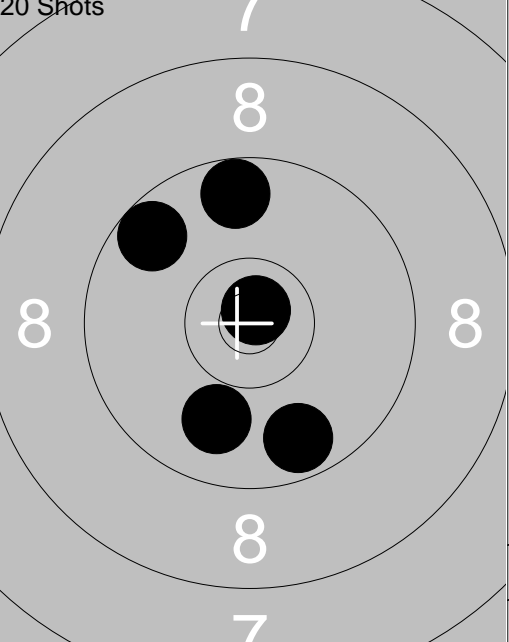
 <p>20 Shots</p>	<p>1: 9.0 → 2: 9.3 ← 3: 9.4 → 4: 9.8 → 5: 9.7 ↓</p> <p>Series 45.0 Total 45.0</p>	 <p>20 Shots</p>	<p>6: *10.8 ↗ 7: 9.7 ↓ 8: 9.9 ↓ 9: 9.6 ↑ 10: 9.6 ←</p> <p>Series 46.0 Total 91.0</p>
---	---	---	--

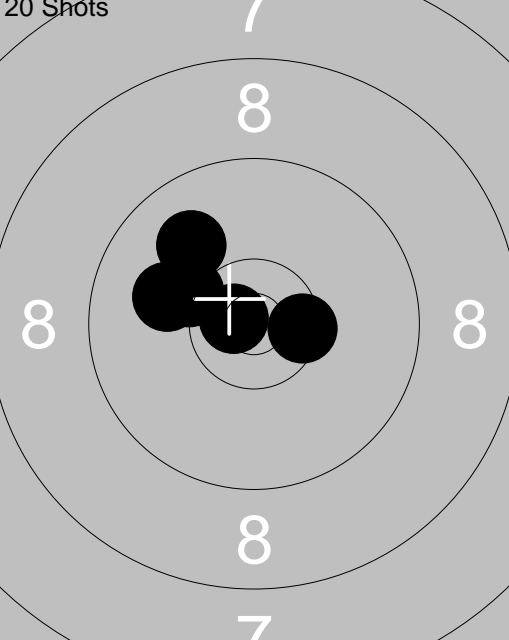
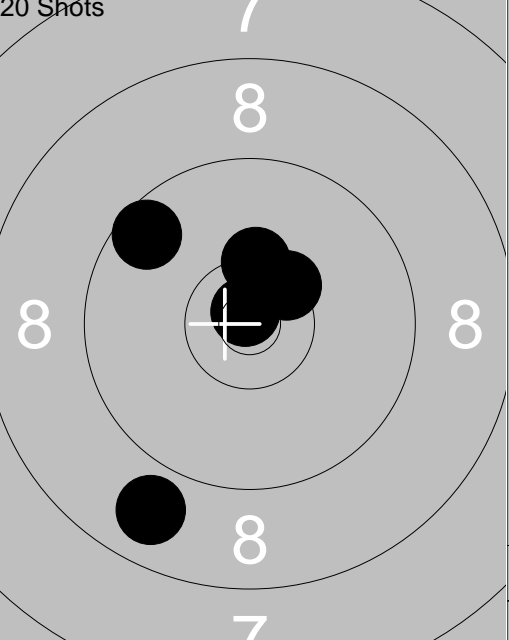
 <p>20 Shots</p>	<p>11: *10.7 ← 12: *10.5 → 13: 10.2 ↙ 14: 10.0 ← 15: 9.9 ↗</p> <p>Series 49.0 Total 140.0</p>	 <p>20 Shots</p>	<p>16: *10.3 ↗ 17: 9.6 ↙ 18: *10.8 ↙ 19: *10.4 ↗ 20: 8.9 ↓</p> <p>Series 47.0 Total 187.0</p>
--	---	--	---

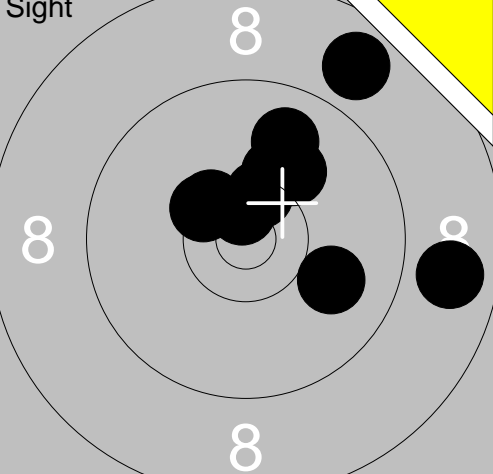
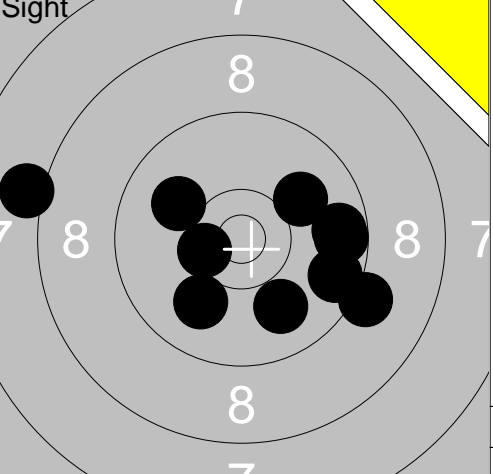
<p>Sight</p> 	<p>1: 8.8 ↗ 2: 10.2 ↗ 3: *10.7 ↑ 4: 10.0 ↘ 5: 8.8 → 6: 10.1 ↗ 7: *10.5 ↑ 8: *10.4 ↗ 9: *10.4 ↗ 10: 9.9 ↑</p> <p>Series 95.0 Total 0.0</p>	<p>Sight</p> 	<p>11: 9.2 → 12: 10.0 ↖ 13: 9.7 → 14: 8.1 ← 15: 9.7 → 16: 10.0 ↗ 17: *10.4 ← 18: 10.0 ↘ 19: 9.9 ↘ 20: 9.6 →</p> <p>Series 93.0 Total 0.0</p>
--	---	--	--

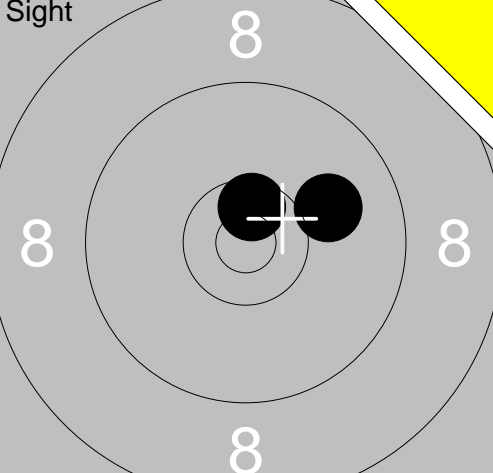
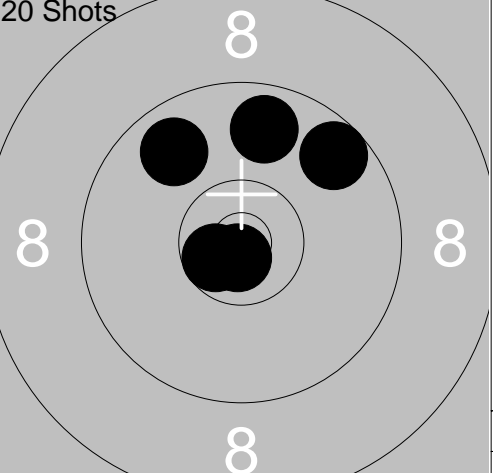
<p>Sight</p> 	<p>21: *10.6 ↑ 22: 10.0 →</p> <p>Series 20.0 Total 0.0</p>	<p>20 Shots</p> 	<p>1: 9.8 ↑ 2: *10.6 ← 3: 9.6 ↗ 4: 9.8 ↗ 5: *10.8 ↓</p> <p>Series 47.0 Total 47.0</p>
---	--	--	---

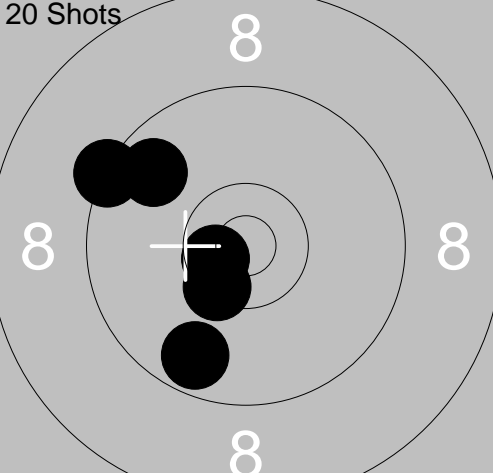
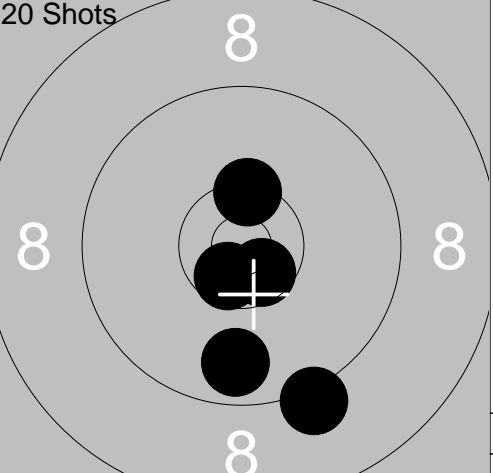
<p>20 Shots</p> 	<p>6: 9.3 ↖ 7: *10.4 ↘ 8: *10.6 ← 9: 9.7 ↗ 10: 9.7 ↘</p> <p>Series 47.0 Total 94.0</p>	<p>20 Shots</p> 	<p>11: *10.4 ↑ 12: *10.6 ↘ 13: 9.2 ↘ 14: *10.6 ↘ 15: 9.7 ↘</p> <p>Series 48.0 Total 142.0</p>
---	--	---	---

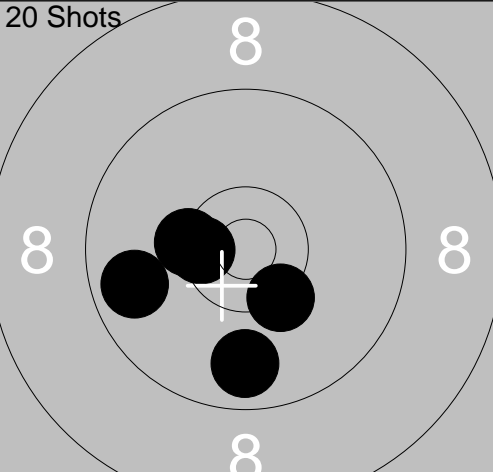
<p>20 Shots</p> 	<p>16: 9.8 ← 17: *10.4 ← 18: *10.5 ← 19: *10.3 ↘ 20: 9.8 ↓</p> <p>Series 48.0 Total 190.0</p>		
---	---	--	--

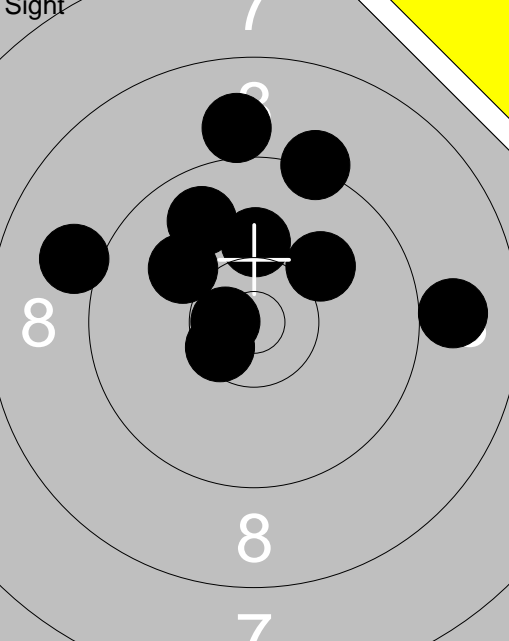
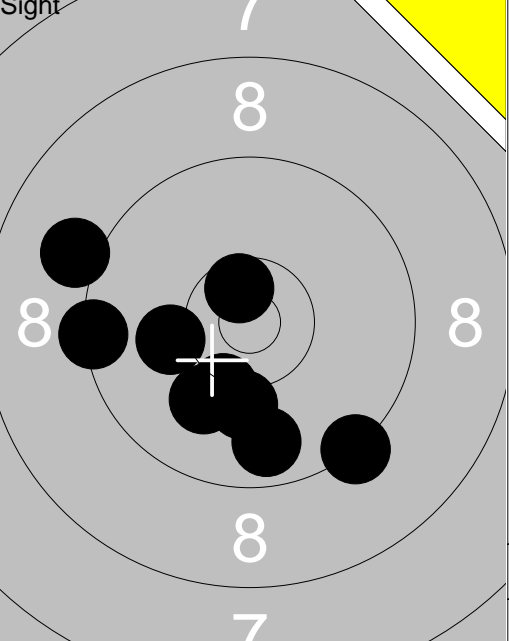
<p>Sight</p>  <p style="text-align:center;">8</p>	<p>1: *10.5 ↘</p> <p>2: 9.0 ↑</p> <p>3: 9.8 ↗</p> <p>4: 10.1 ↖</p> <p>5: 10.1 ↗</p> <p>6: 10.2 ↑</p> <p>7: 9.3 ↑</p> <p>8: 9.0 →</p> <p>9: *10.7 ↖</p> <p>10: 9.0 ←</p> <p>Series 95.0</p> <p>Total 0.0</p>	<p>Sight</p>  <p style="text-align:center;">8</p>	<p>11: 9.1 ↖</p> <p>12: 10.1 ↓</p> <p>13: 9.3 ↘</p> <p>14: 9.7 ↓</p> <p>15: 10.1 ↘</p> <p>16: 10.2 ↓</p> <p>17: 10.1 ←</p> <p>18: 9.4 ←</p> <p>19: *10.6 ↗</p> <p>Series 86.0</p> <p>Total 0.0</p>
---	---	---	--

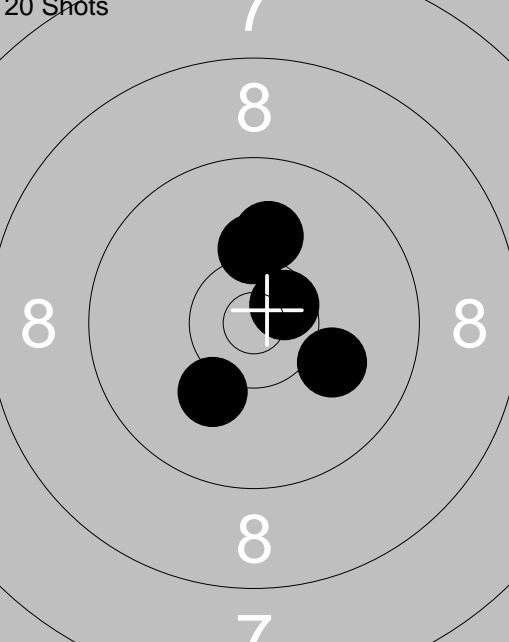
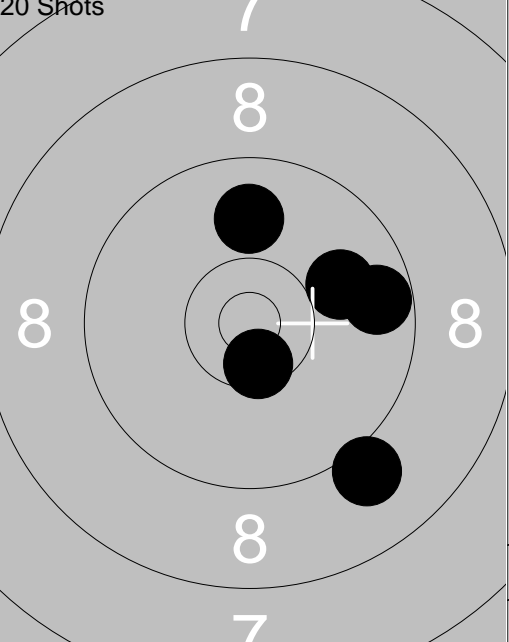
<p>20 Shots</p>  <p style="text-align:center;">8</p>	<p>1: 10.1 →</p> <p>2: *10.6 ↗</p> <p>3: 10.1 ↑</p> <p>4: 10.1 ↘</p> <p>5: 10.2 ↑</p> <p>Series 50.0</p> <p>Total 50.0</p>	<p>20 Shots</p>  <p style="text-align:center;">8</p>	<p>6: 9.9 ↑</p> <p>7: 10.0 →</p> <p>8: *10.5 ↓</p> <p>9: 9.1 ↘</p> <p>10: 9.7 →</p> <p>Series 47.0</p> <p>Total 97.0</p>
---	--	---	--

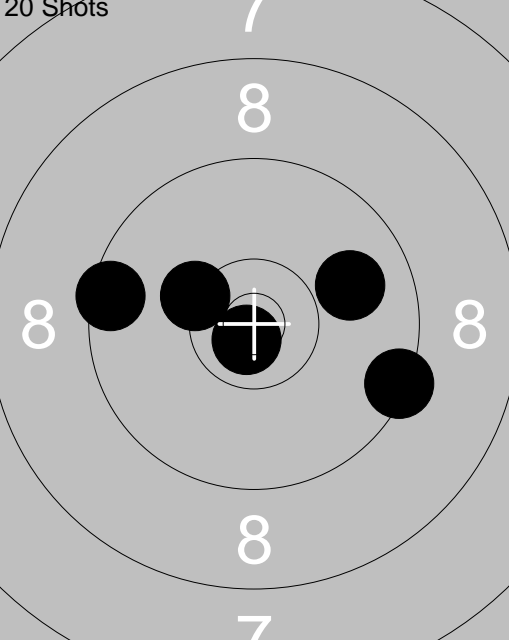
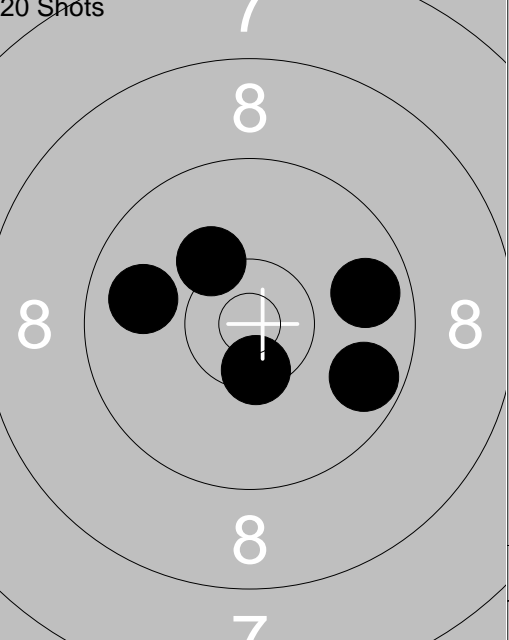
<p>20 Shots</p>  <p style="text-align:center;">8</p>	<p>11: *10.3 ↖</p> <p>12: *10.8 ↘</p> <p>13: 9.9 →</p> <p>14: 9.4 →</p> <p>15: 9.5 ←</p> <p>Series 47.0</p> <p>Total 144.0</p>	<p>20 Shots</p>  <p style="text-align:center;">8</p>	<p>16: 10.2 ↖</p> <p>17: *10.5 ↓</p> <p>18: 9.9 ←</p> <p>19: 9.7 →</p> <p>20: 9.8 →</p> <p>Series 47.0</p> <p>Total 191.0</p>
--	--	--	---

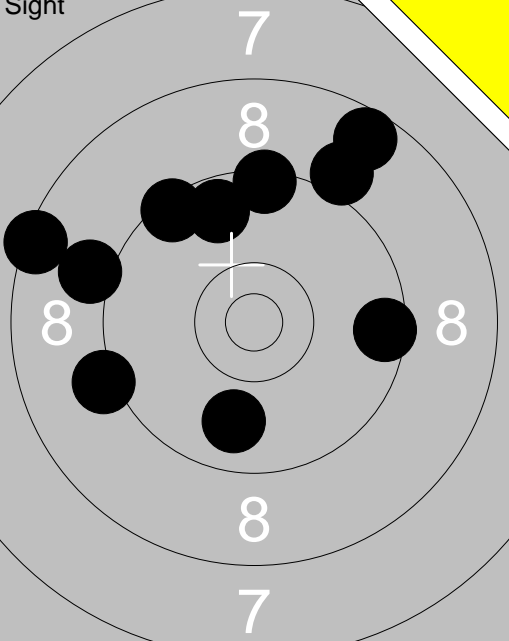
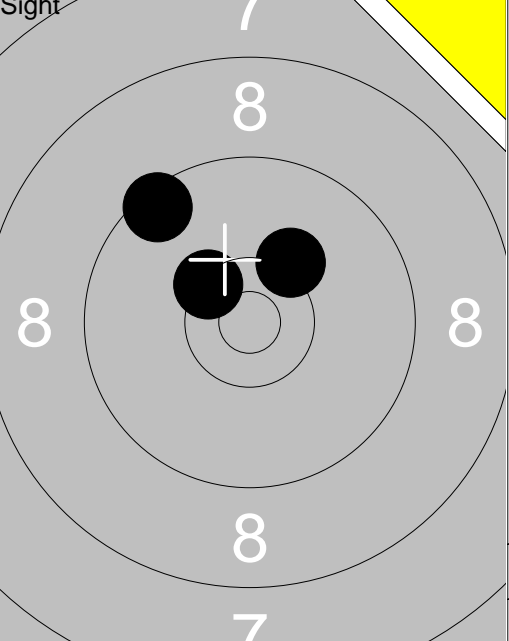
 <p style="text-align: center;">Sight</p>	<p>1: 9.2 ←</p> <p>2: 9.7 ↑</p> <p>3: 9.8 ↓</p> <p>4: 9.4 ↖</p> <p>5: 9.1 ↗</p> <p>6: 9.1 ←</p> <p>7: 8.6 ↗</p> <p>8: 9.5 →</p> <p>9: 8.4 ←</p> <p>10: 9.4 ↑</p>	 <p style="text-align: center;">Sight</p>	<p>11: *10.4 ↘</p> <p>12: 9.5 ↖</p> <p>13: 10.2 ↗</p>
Series 88.0		Series 29.0	
Total 0.0		Total 0.0	

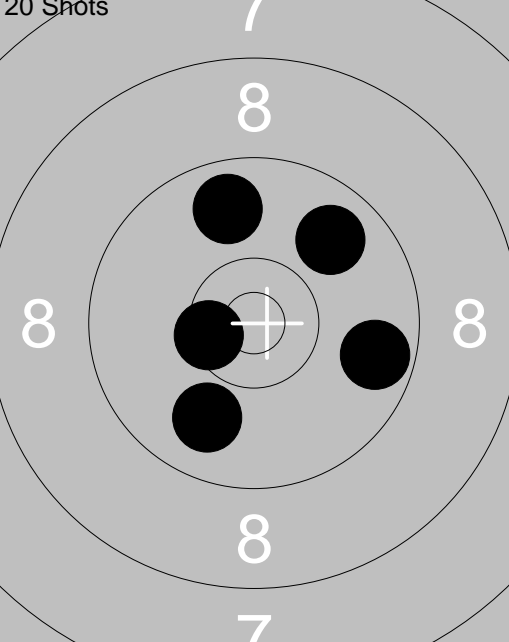
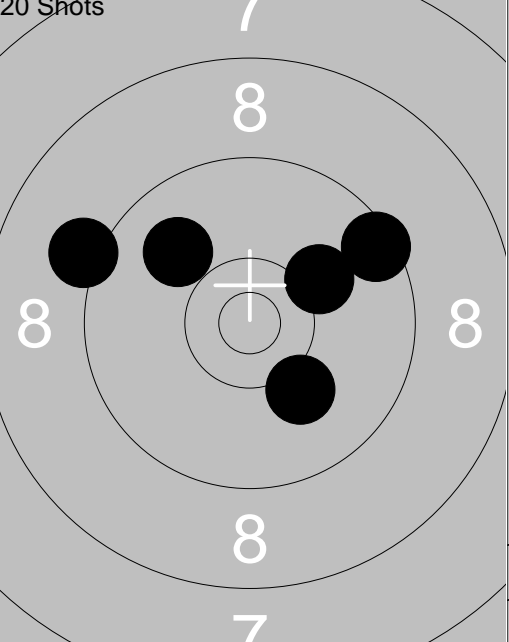
 <p style="text-align: center;">20 Shots</p>	<p>1: 9.7 →</p> <p>2: 9.8 ↑</p> <p>3: 9.9 ↓</p> <p>4: *10.5 ←</p> <p>5: 9.8 ↗</p>	 <p style="text-align: center;">20 Shots</p>	<p>6: 9.5 ↗</p> <p>7: 9.2 ←</p> <p>8: 10.1 ↗</p> <p>9: 9.9 ↖</p> <p>10: 10.1 ↓</p>
Series 46.0		Series 47.0	
Total 46.0		Total 93.0	

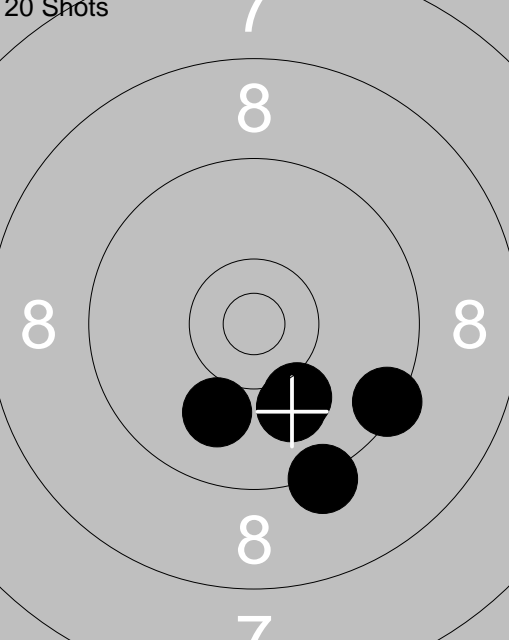
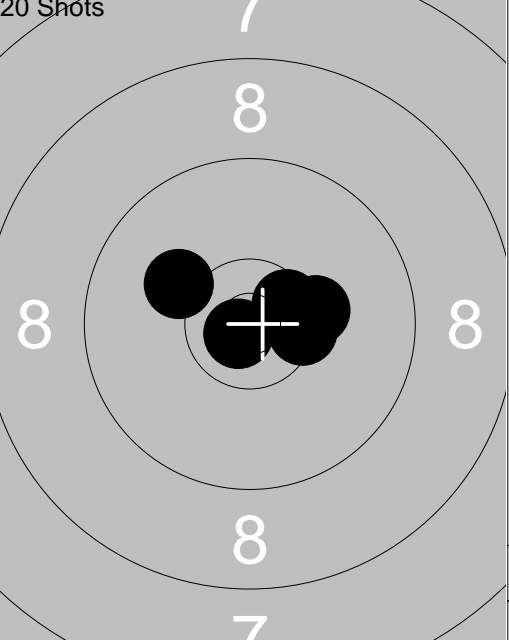
 <p style="text-align: center;">20 Shots</p>	<p>11: 9.4 →</p> <p>12: 9.3 ↓</p> <p>13: 10.0 ↓</p> <p>14: 10.1 ↓</p> <p>15: 10.0 ↓</p>	 <p style="text-align: center;">20 Shots</p>	<p>16: *10.8 ↘</p> <p>17: 10.1 ↖</p> <p>18: *10.5 ↗</p> <p>19: 10.3 →</p> <p>20: *10.4 →</p>
Series 48.0		Series 50.0	
Total 141.0		Total 191.0	

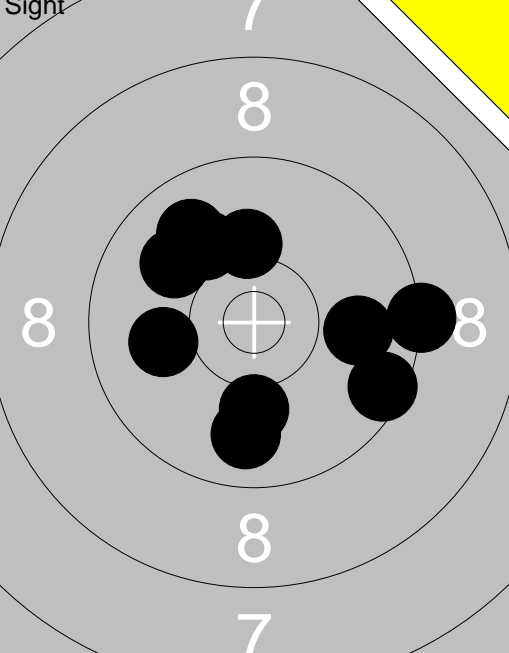
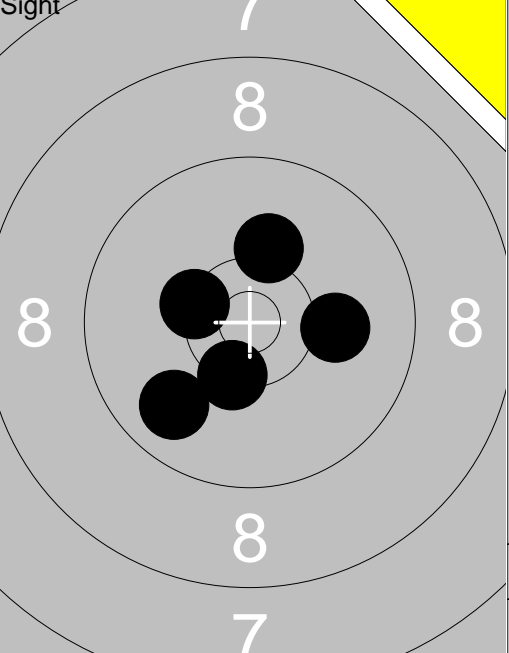
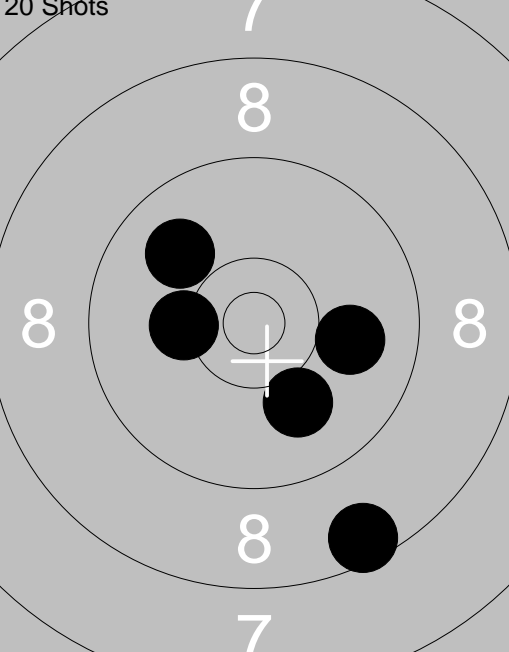
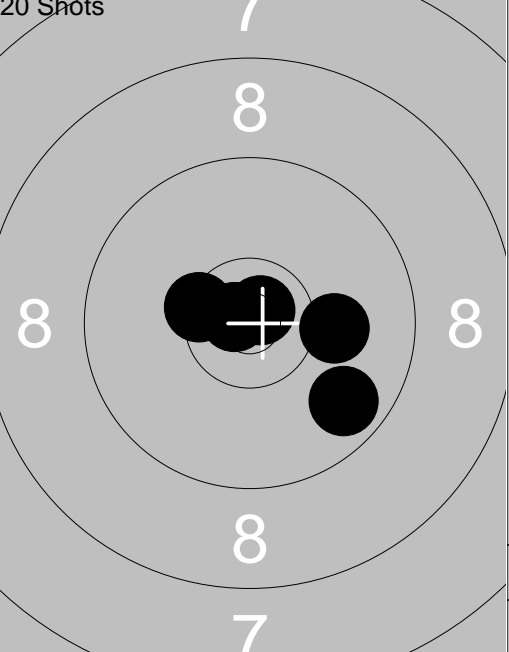
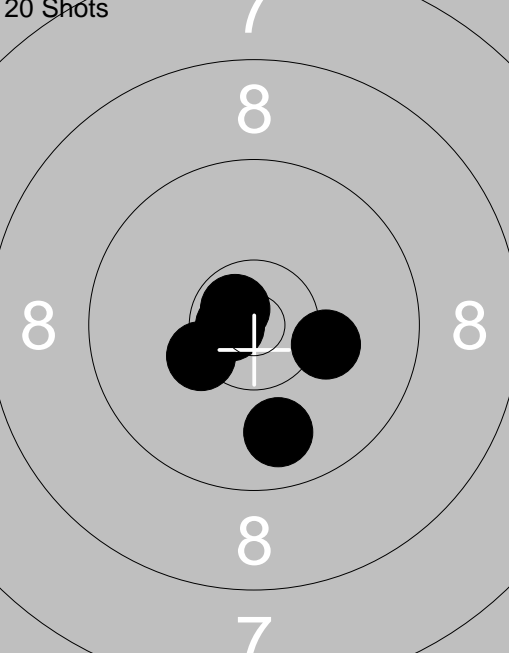
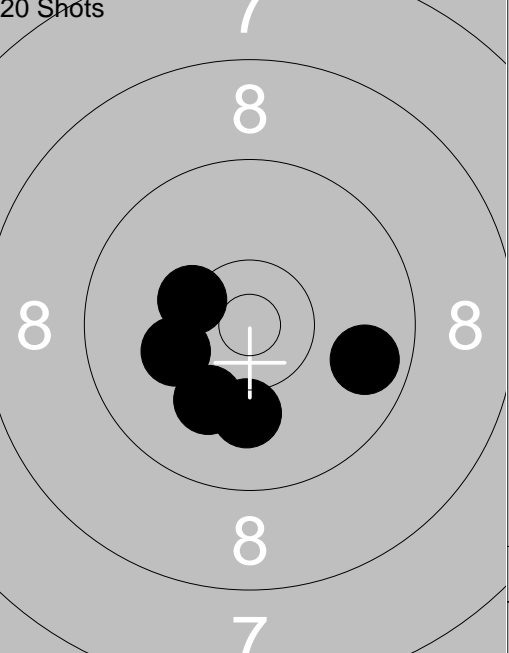
<p>Sight</p>  <p style="text-align: center;">7</p>	<p>1: 9.5 →</p> <p>2: 9.3 →</p> <p>3: 10.0 ↖</p> <p>4: 9.9 →</p> <p>5: 10.2 ↑</p> <p>6: 10.0 ←</p> <p>7: 9.9 ↖</p> <p>8: 10.0 ↖</p> <p>9: 9.8 ↓</p> <p>10: 10.1 ↓</p> <hr/> <p>Series 95.0</p> <hr/> <p>Total 0.0</p>	<p>Sight</p>  <p style="text-align: center;">7</p>	<p>11: *10.4 ↖</p> <p>12: 9.8 ↙</p> <p>13: *10.4 ↓</p> <p>14: 10.1 →</p> <p>15: 10.2 ↑</p> <hr/> <p>Series 49.0</p> <hr/> <p>Total 0.0</p>
<p>20 Shots</p>  <p style="text-align: center;">7</p>	<p>1: 8.6 ↓</p> <p>2: 9.9 ↖</p> <p>3: 10.0 ↓</p> <p>4: 10.0 →</p> <p>5: 10.2 ←</p> <hr/> <p>Series 47.0</p> <hr/> <p>Total 47.0</p>	<p>20 Shots</p>  <p style="text-align: center;">7</p>	<p>6: *10.4 ↖</p> <p>7: *10.8 ↗</p> <p>8: 9.7 ↓</p> <p>9: *10.8 ↖</p> <p>10: 10.1 →</p> <hr/> <p>Series 49.0</p> <hr/> <p>Total 96.0</p>
<p>20 Shots</p>  <p style="text-align: center;">7</p>	<p>11: 9.9 ↓</p> <p>12: *10.7 ↖</p> <p>13: *10.3 ↙</p> <p>14: 10.2 →</p> <p>15: *10.7 ↖</p> <hr/> <p>Series 49.0</p> <hr/> <p>Total 145.0</p>	<p>20 Shots</p>  <p style="text-align: center;">7</p>	<p>16: 10.1 ↓</p> <p>17: 10.1 ↓</p> <p>18: 10.2 ←</p> <p>19: *10.3 ↖</p> <p>20: 9.8 →</p> <hr/> <p>Series 49.0</p> <hr/> <p>Total 194.0</p>

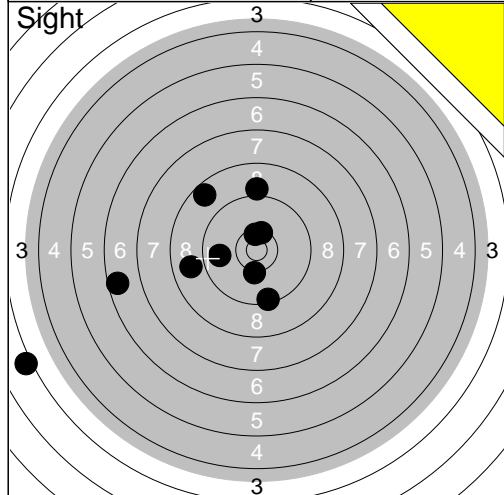

1:	3.1	←
2:	6.6	←
3:	8.9	←
4:	8.6	↗
5:	10.3	↓
6:	9.8	←
7:	9.4	↓
8:	*10.4	↑
9:	*10.5	↑
10:	9.1	↑
Series		82.0
Total		0.0

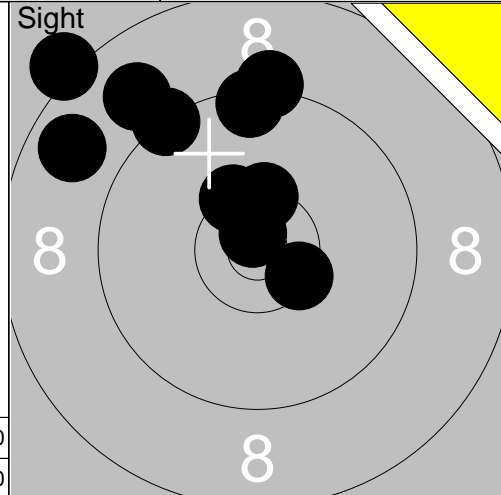

11:	*10.8	↑
12:	8.8	↖
13:	9.3	↗
14:	8.2	↗
15:	*10.4	↗
16:	9.4	↑
17:	9.2	↑
18:	8.9	↗
19:	*10.4	↘
20:	*10.4	↑
Series		91.0
Total		0.0

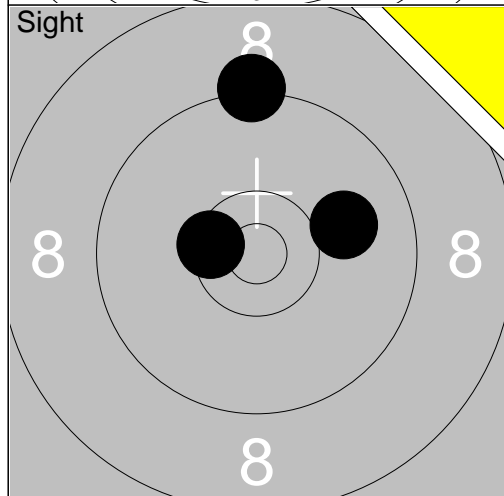

21:	*10.5	←
22:	9.2	↑
23:	10.0	→
Series		29.0
Total		0.0

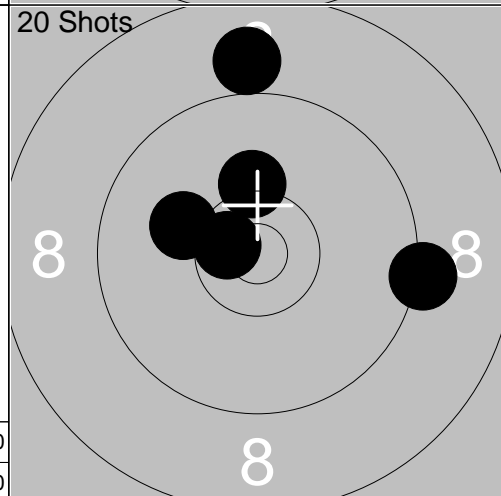

1:	9.2	→
2:	*10.6	←
3:	10.1	←
4:	9.0	↑
5:	10.2	↑
Series		48.0
Total		48.0

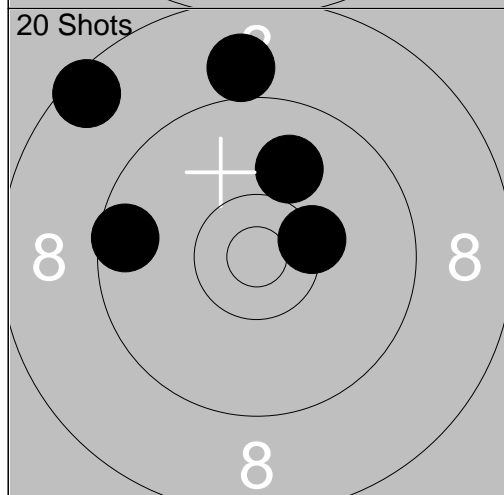

6:	8.5	↖
7:	10.0	↑
8:	*10.4	→
9:	9.6	←
10:	9.0	↑
Series		46.0
Total		94.0

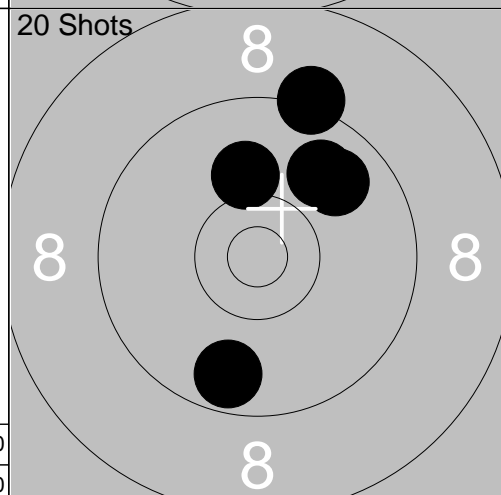

11:	9.9	↗
12:	9.2	↑
13:	9.7	↓
14:	10.1	↑
15:	9.8	↗
Series		46.0
Total		140.0

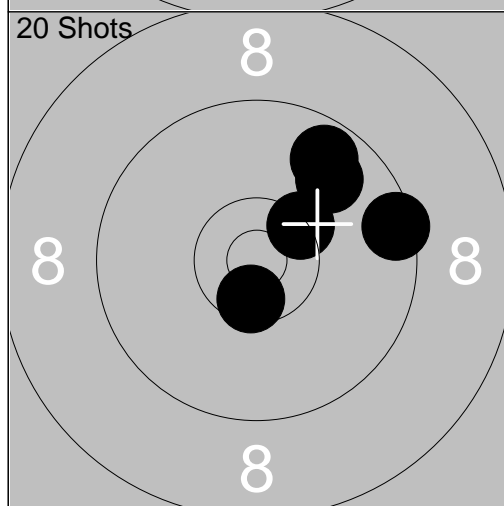

16:	*10.5	↓
17:	*10.4	↗
18:	9.8	↗
19:	9.7	↗
20:	9.5	→
Series		47.0
Total		187.0

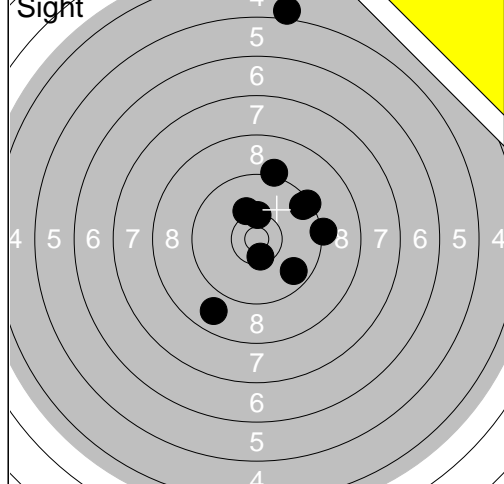

1:	5.1	↑
2:	9.2	→
3:	9.4	↗
4:	9.2	↑
5:	10.2	↑
6:	*10.3	↑
7:	*10.5	↓
8:	9.7	↘
9:	9.5	↗
10:	8.8	↙
Series		88.0
Total		0.0

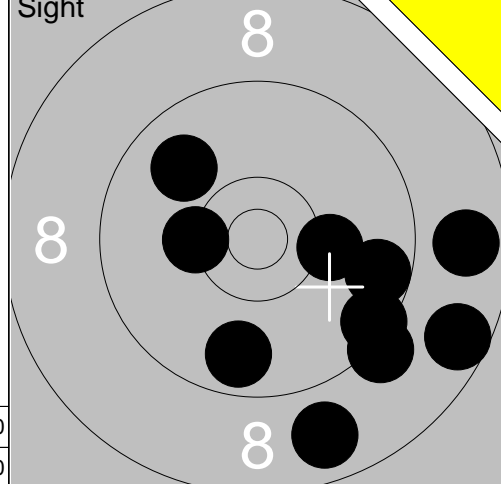

11:	8.8	↘
12:	*10.3	←
13:	9.9	↗
14:	9.7	↘
15:	9.7	↘
16:	9.2	↘
17:	10.2	→
18:	8.6	↘
19:	8.8	→
20:	9.5	↘
Series		89.0
Total		0.0

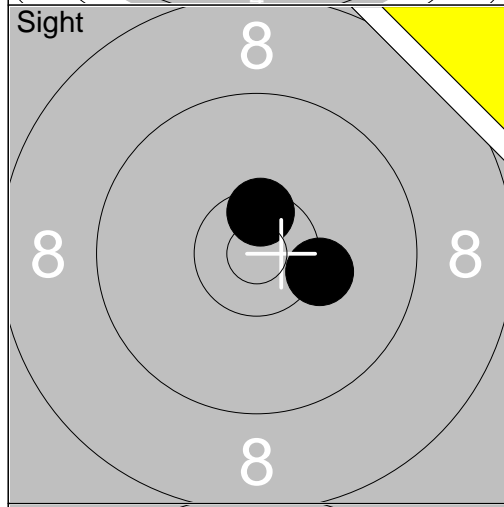

21:	*10.5	↑
22:	10.3	→
Series		20.0
Total		0.0

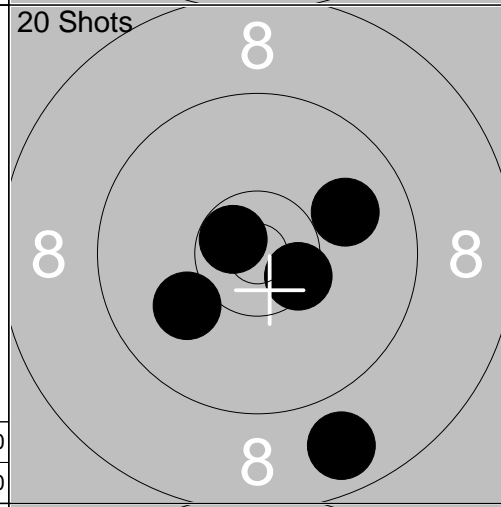

1:	8.8	↘
2:	*10.5	↘
3:	10.0	↙
4:	9.9	↗
5:	*10.7	↖
Series		47.0
Total		47.0

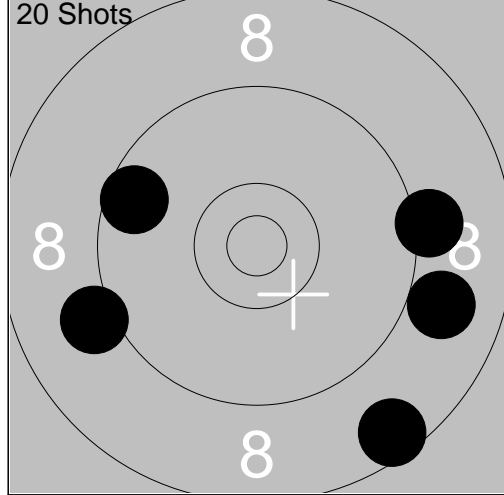

6:	9.1	↙
7:	8.6	↘
8:	9.6	↖
9:	8.9	→
10:	9.2	→
Series		43.0
Total		90.0

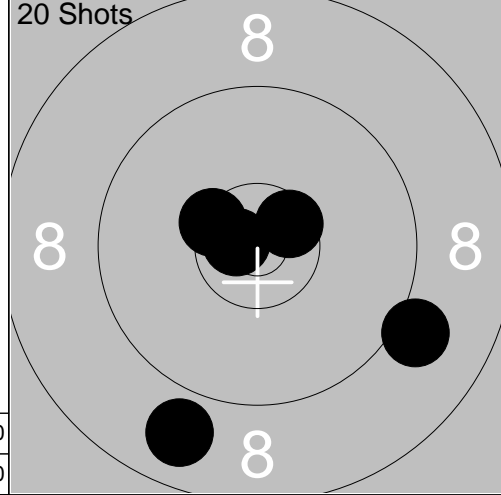

11:	*10.4	↖
12:	8.9	↘
13:	9.1	↘
14:	*10.7	←
15:	*10.6	↗
Series		47.0
Total		137.0

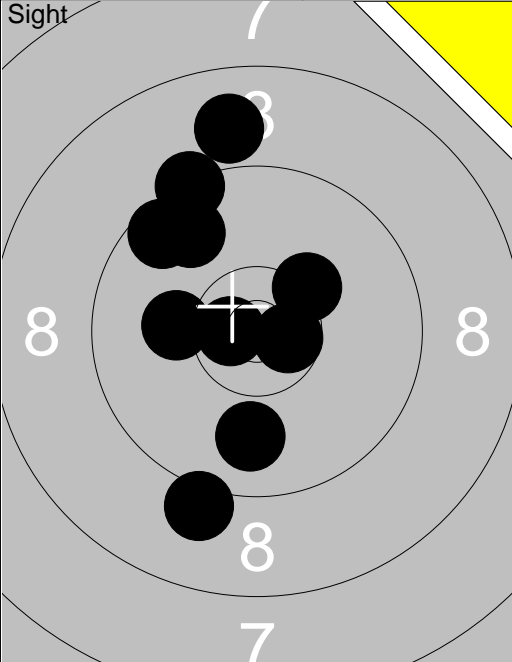
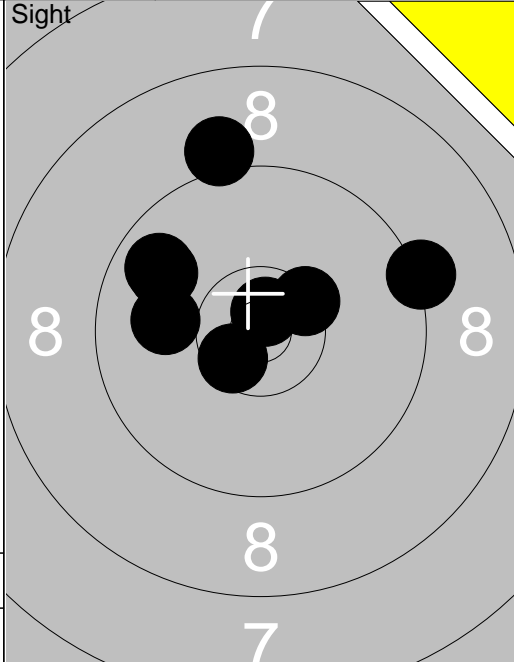
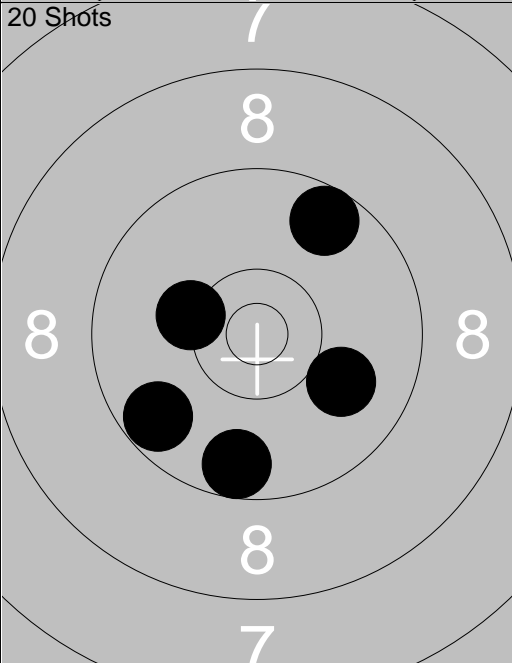
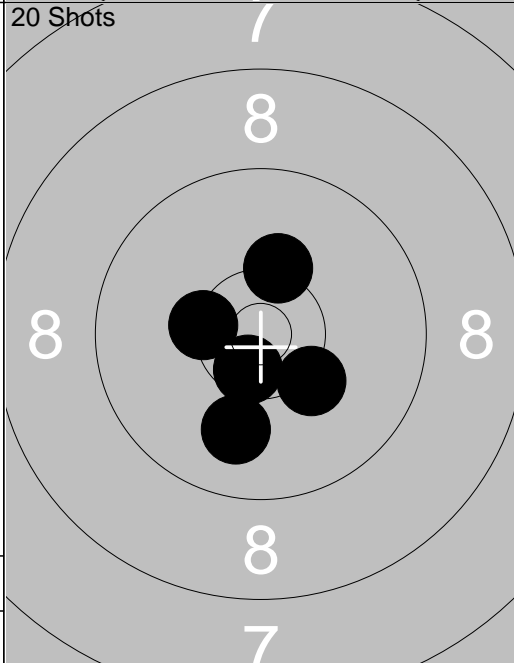
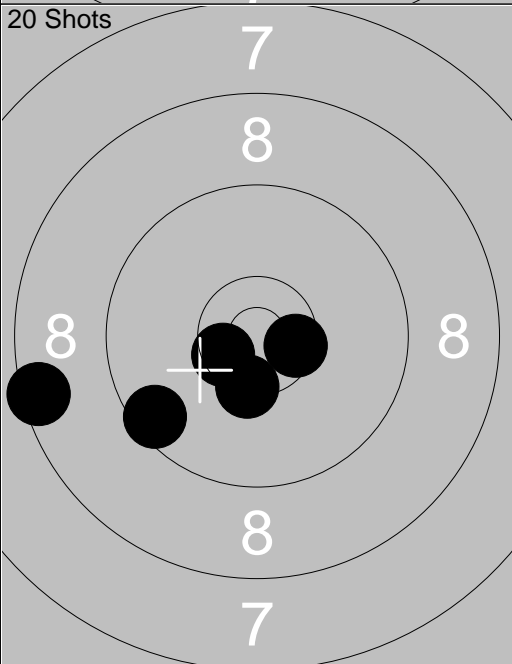
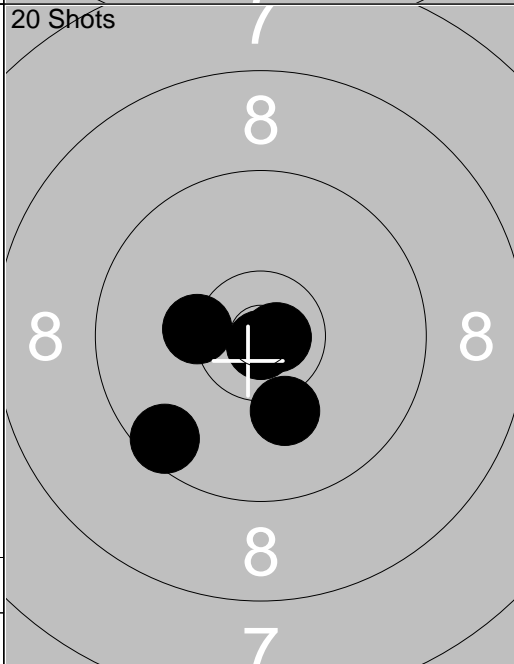

16:	10.1	↘
17:	8.3	↘
18:	9.3	↘
19:	9.4	↑
20:	9.5	→
Series		45.0
Total		182.0

<p>Sight</p>  <p>Series 93.0 Total 0.0</p>	<p>1: 8.9 ↑ 2: *10.6 → 3: 9.6 ↖ 4: 10.3 ↗ 5: 10.1 ← 6: 9.8 ↖ 7: 9.9 ↓ 8: 9.1 ↓ 9: 9.4 ↑ 10: *10.7 ↖</p>	<p>Sight</p>  <p>Series 76.0 Total 0.0</p>	<p>11: 9.1 ↑ 12: 9.8 ↖ 13: *10.4 ↗ 14: *10.6 ↘ 15: *10.8 ↑ 16: 10.0 ← 17: 9.8 ↖ 18: 9.3 →</p>
<p>20 Shots</p>  <p>Series 47.0 Total 47.0</p>	<p>1: 10.0 → 2: 10.3 ← 3: 9.6 ↓ 4: 9.6 ↗ 5: 9.7 ↖</p>	<p>20 Shots</p>  <p>Series 50.0 Total 97.0</p>	<p>6: 10.3 ↑ 7: 10.0 ↓ 8: *10.4 ↖ 9: *10.6 ↘ 10: 10.3 ↘</p>
<p>20 Shots</p>  <p>Series 47.0 Total 144.0</p>	<p>11: *10.5 ↘ 12: 8.5 ← 13: 9.5 ↖ 14: *10.5 → 15: *10.4 ↓</p>	<p>20 Shots</p>  <p>Series 49.0 Total 193.0</p>	<p>16: 9.5 ↘ 17: *10.8 → 18: 10.2 ↓ 19: *10.3 ↖ 20: *10.9 ↓</p>

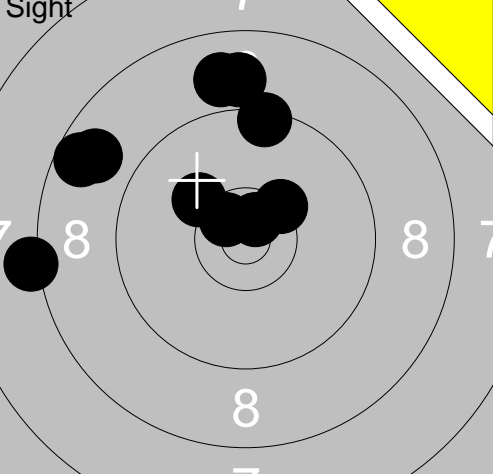
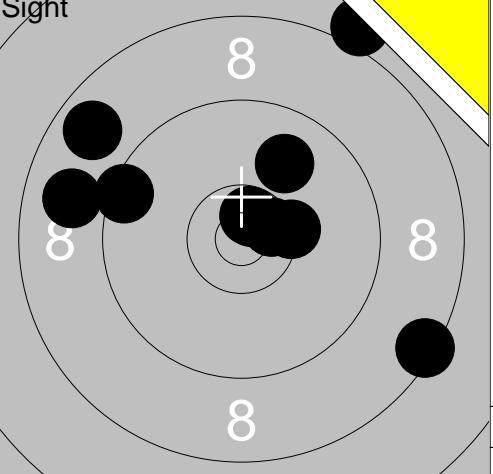
	<p>1: 8.6 ↙</p> <p>2: 8.2 ←</p> <p>3: *10.7 ↗</p> <p>4: 8.8 ↖</p> <p>5: *10.6 ↗</p> <p>6: 8.9 ↑</p> <p>7: 10.2 ↗</p> <p>8: 9.4 ↑</p> <p>9: 8.9 ↑</p> <p>10: *10.3 ↗</p>		<p>11: 9.5 ↙</p> <p>12: 9.9 ↗</p> <p>13: *10.7 ↗</p> <p>14: 8.8 ↖</p> <p>15: *10.7 ↗</p> <p>16: 8.1 ↗</p> <p>17: 8.9 ←</p> <p>18: *10.3 →</p> <p>19: 8.4 ↘</p> <p>20: *10.6 →</p>
Series 89.0	Total 0.0	Series 90.0	Total 0.0

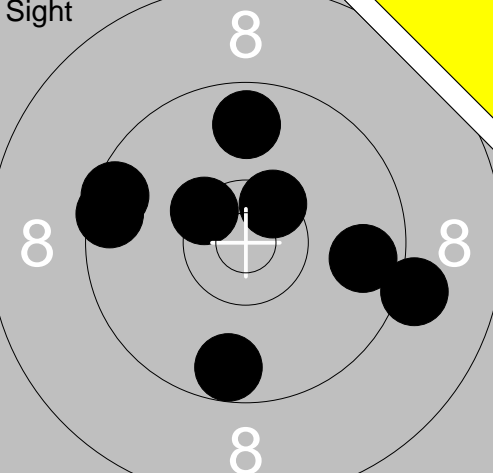
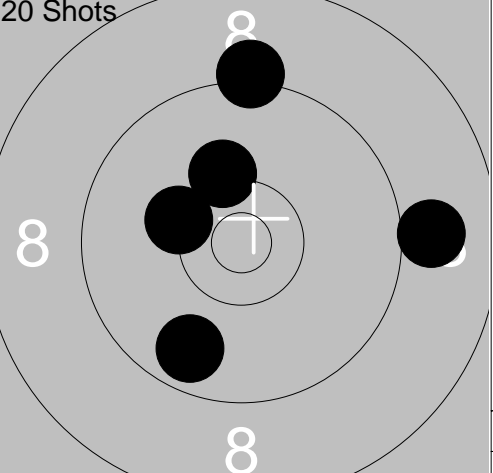
	<p>21: 9.5 ↙</p> <p>22: *10.5 ↗</p> <p>23: 9.7 ↑</p> <p>24: 9.7 →</p> <p>25: *10.4 ↗</p> <p>26: 9.5 ←</p> <p>27: 9.7 ↓</p> <p>28: 9.1 →</p>		<p>1: 10.2 ↑</p> <p>2: 10.3 ←</p> <p>3: 9.2 ↑</p> <p>4: 9.0 →</p> <p>5: 9.7 ↓</p>
Series 74.0	Total 0.0	Series 47.0	Total 47.0

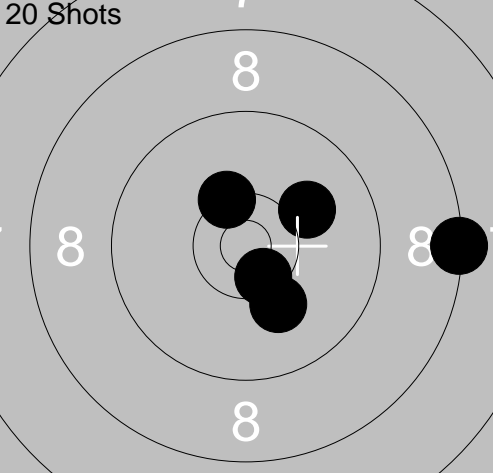
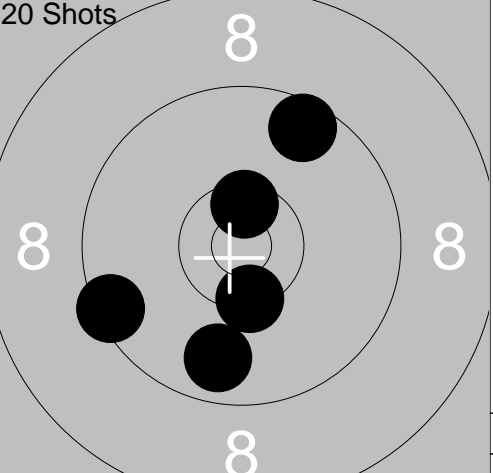
	<p>6: 10.1 ↓</p> <p>7: 8.3 →</p> <p>8: 10.1 ↗</p> <p>9: *10.5 ↓</p> <p>10: *10.3 ↗</p>		<p>11: 9.8 ↓</p> <p>12: *10.4 ↓</p> <p>13: 9.5 ↖</p> <p>14: 9.6 ↗</p> <p>15: *10.5 ↑</p>
Series 48.0	Total 95.0	Series 47.0	Total 142.0

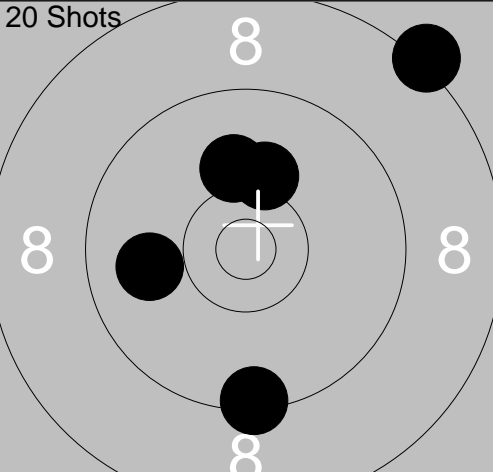
	<p>16: 10.1 ↑</p> <p>17: 10.2 ↑</p> <p>18: 8.2 ↗</p> <p>19: 9.4 ↓</p> <p>20: 9.9 ←</p>		
Series 46.0	Total 188.0		

--	--

--	--

--	--

--	--

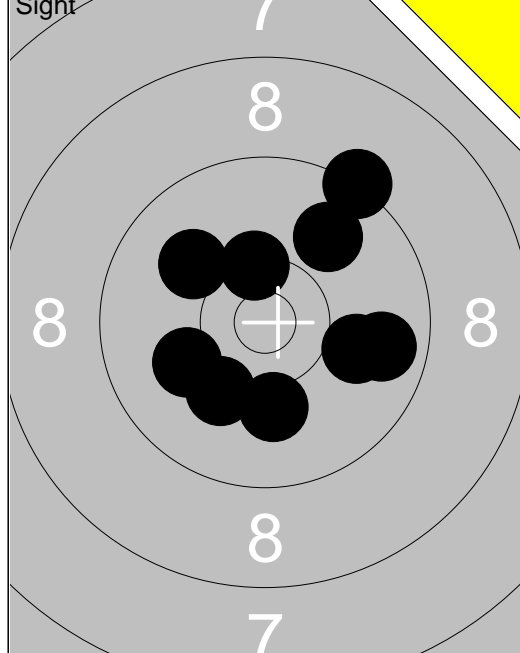

- 1: 9.9 ↗
- 2: 9.3 ↗
- 3: 10.0 ↖
- 4: *10.4 ↑
- 5: 10.0 →
- 6: 10.1 ↓
- 7: 10.1 ↖
- 8: 9.8 →
- 9: 10.1 ↓

Series 87.0
Total 0.0

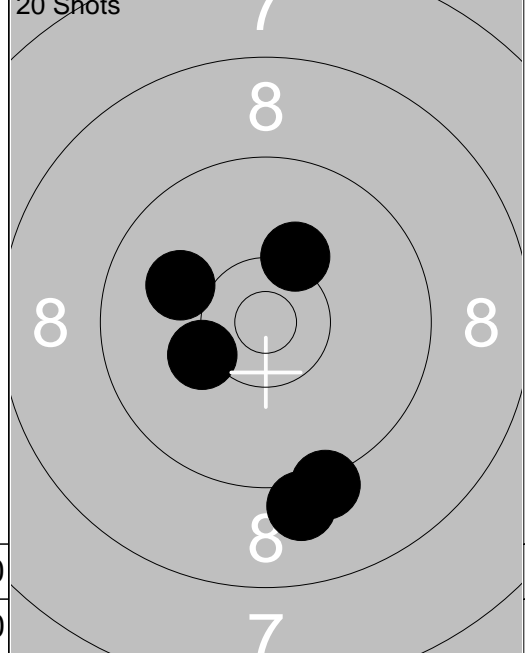

- 1: 9.1 ↓
- 2: 10.2 ↖
- 3: 9.2 ↓
- 4: 10.2 ↗
- 5: 10.0 ↖

Series 48.0
Total 48.0

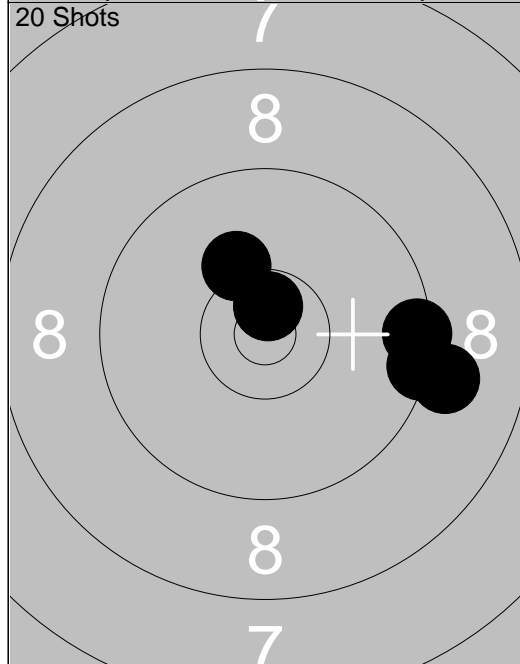

- 6: 9.4 →
- 7: 9.4 →
- 8: *10.7 ↑
- 9: 10.2 ↗
- 10: 9.1 →

Series 47.0
Total 95.0

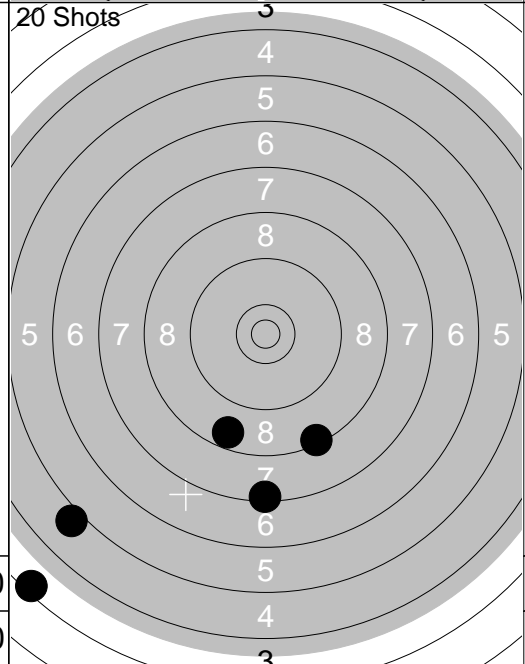

- 11: 8.4 ↓
- 12: 8.6 ↓
- 13: 7.4 ↓
- 14: 3.4 ↖
- 15: 5.1 ↖

Series 31.0
Total 126.0

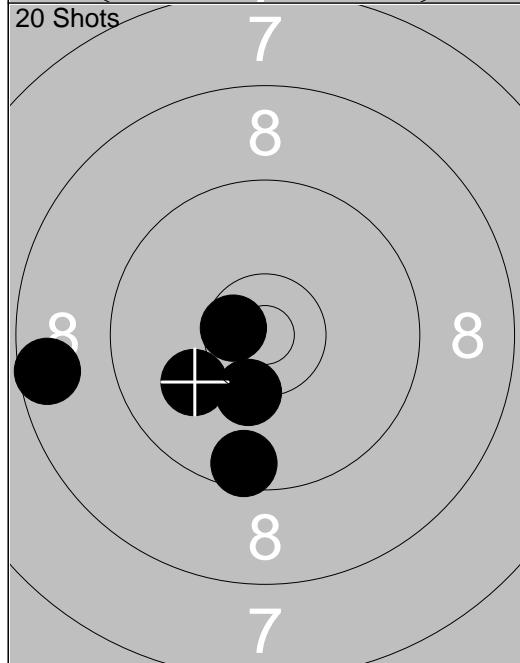

- 16: 8.6 ←
- 17: *10.3 ↓
- 18: 10.0 ↖
- 19: *10.6 ↖
- 20: 9.6 ↓

Series 47.0
Total 173.0

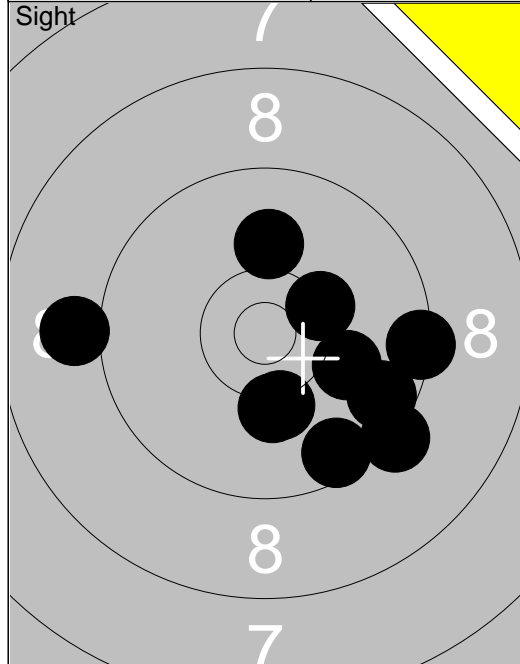

1:	10.1	↑
2:	9.3	↘
3:	10.2	↓
4:	9.0	←
5:	10.1	→
6:	9.4	→
7:	10.2	↓
8:	9.6	↓
9:	*10.3	↗
10:	9.6	↘
Series		95.0
Total		0.0

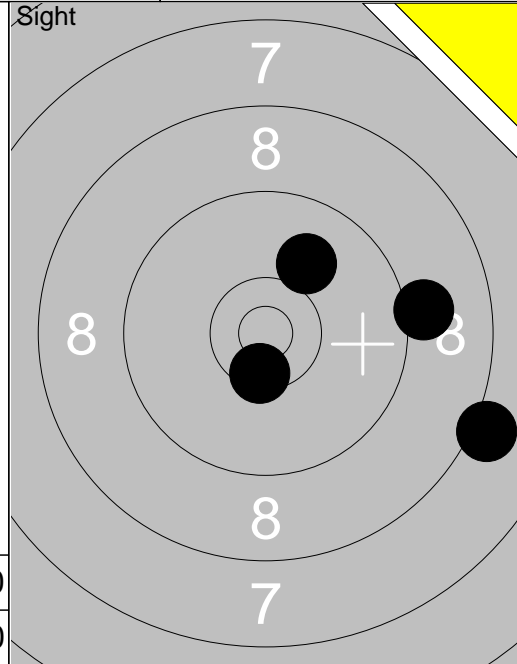

11:	8.1	↘
12:	9.1	→
13:	10.0	↗
14:	*10.5	↓
Series		37.0
Total		0.0

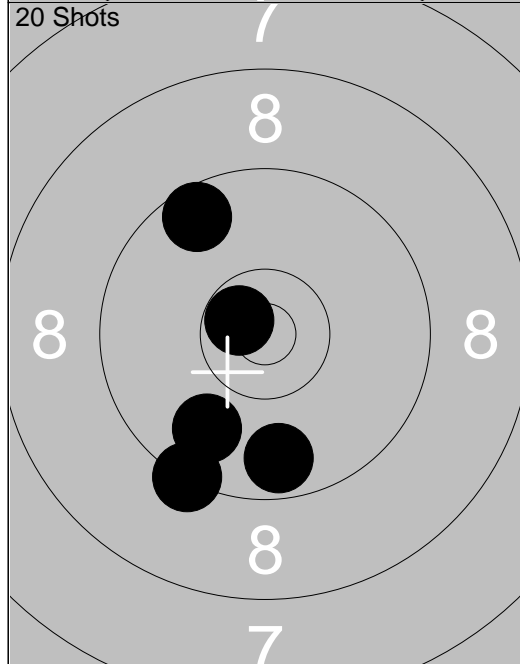

1:	9.8	↘
2:	9.6	↗
3:	*10.7	↗
4:	9.7	↓
5:	9.3	↘
Series		46.0
Total		46.0

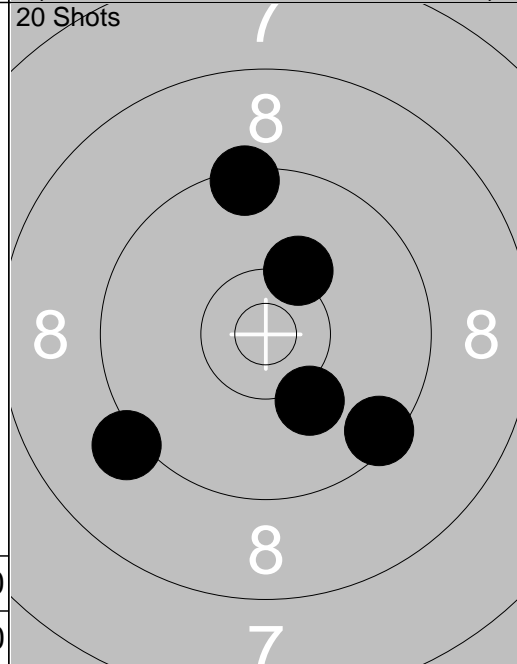

6:	10.2	↗
7:	10.2	↘
8:	9.5	↘
9:	9.4	↑
10:	9.2	↙
Series		47.0
Total		93.0

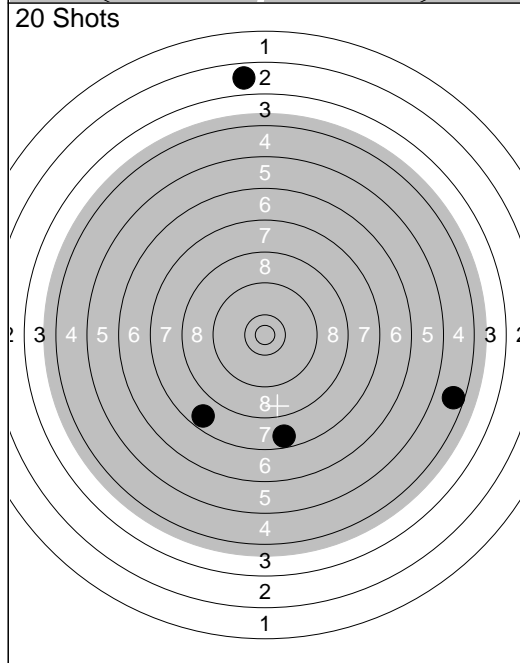

11:	0.0	↓
12:	2.8	↑
13:	7.7	↓
14:	7.7	↙
15:	4.7	→
Series		20.0
Total		113.0

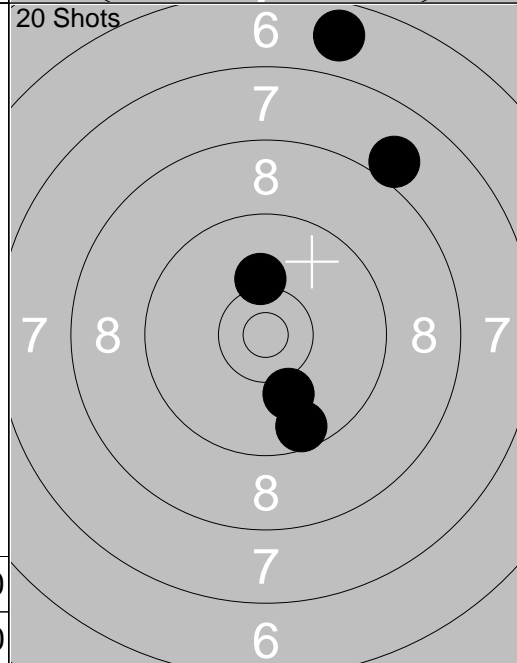

16:	6.8	↑
17:	10.2	↑
18:	8.0	↗
19:	10.1	↘
20:	9.6	↘
Series		43.0
Total		156.0

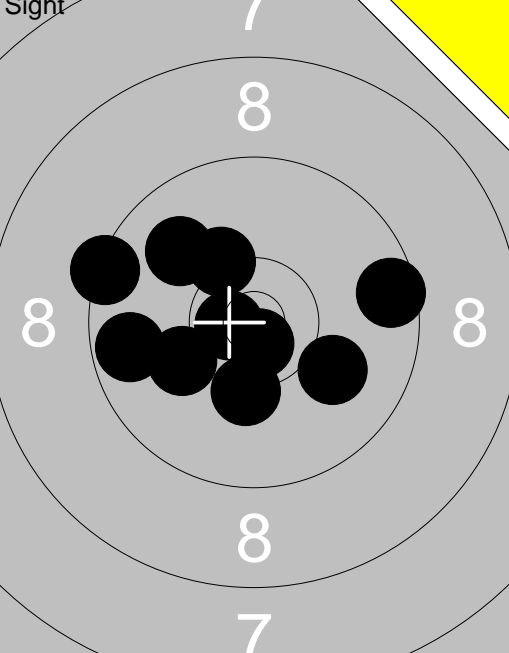
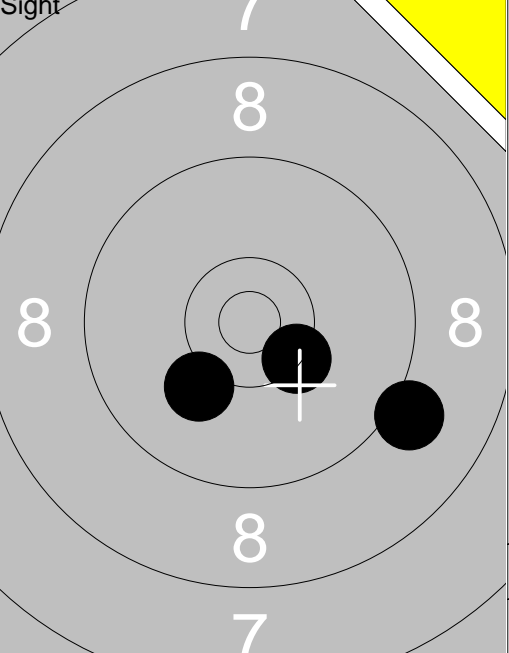
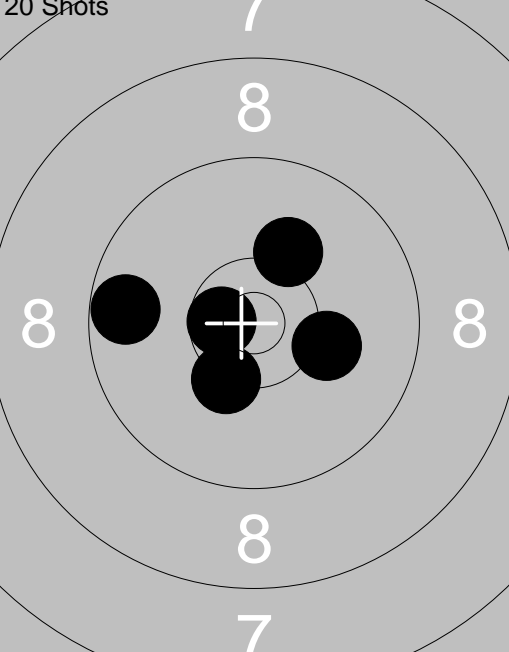
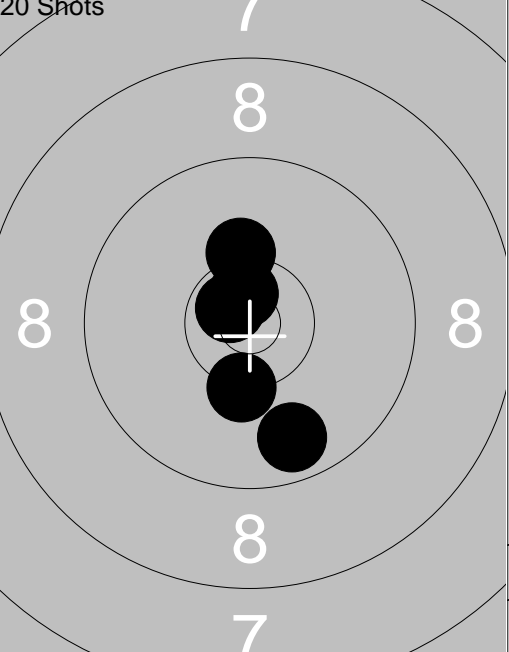
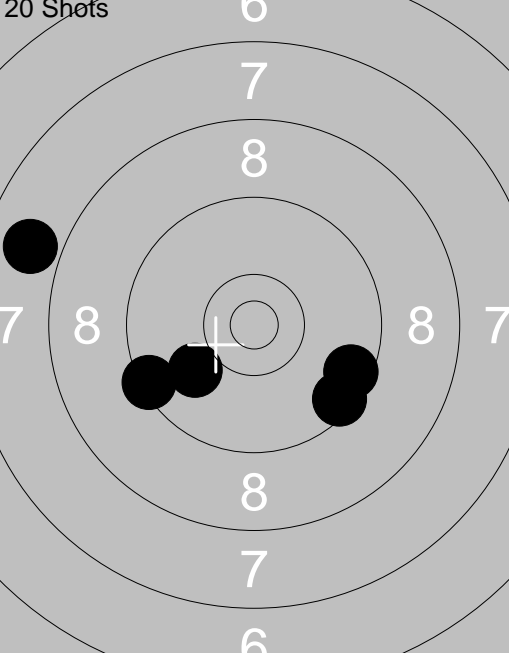
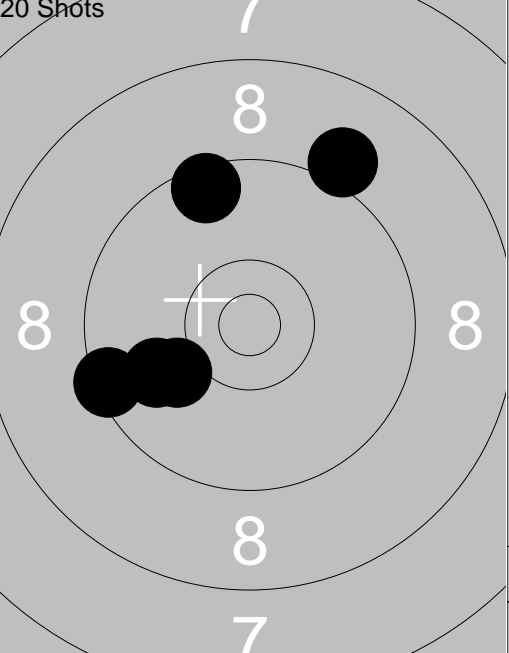
<p>Sight</p>  <p style="text-align: center;">8 8 8 8</p>	<p>1: 9.4 ← 2: *10.7 ↖ 3: 10.0 → 4: 10.3 ↗ 5: 10.1 ← 6: 9.6 → 7: 10.3 ↓ 8: 9.7 ← 9: *10.7 ↓ 10: 9.9 ↖</p> <p>Series 96.0 Total 0.0</p>	<p>Sight</p>  <p style="text-align: center;">8 8 8</p>	<p>11: 10.1 ↘ 12: 9.1 → 13: *10.4 ↘</p> <p>Series 29.0 Total 0.0</p>
<p>20 Shots</p>  <p style="text-align: center;">8 8 8</p>	<p>1: 9.7 ← 2: 10.2 ↗ 3: 10.2 → 4: *10.6 ← 5: *10.3 ↓</p> <p>Series 49.0 Total 49.0</p>	<p>20 Shots</p>  <p style="text-align: center;">8 8 8</p>	<p>6: *10.7 ↗ 7: 9.7 ↓ 8: *10.3 ↓ 9: *10.7 ↖ 10: 10.2 ↗</p> <p>Series 49.0 Total 98.0</p>
<p>20 Shots</p>  <p style="text-align: center;">7 7 8 8 7</p>	<p>11: 9.5 → 12: 9.4 ← 13: 7.9 ← 14: 10.0 ↙ 15: 9.6 →</p> <p>Series 44.0 Total 142.0</p>	<p>20 Shots</p>  <p style="text-align: center;">8 8 8 8 7</p>	<p>16: 9.5 ↗ 17: 9.9 ↙ 18: 9.1 ↗ 19: 10.1 ↙ 20: 9.4 ←</p> <p>Series 46.0 Total 188.0</p>

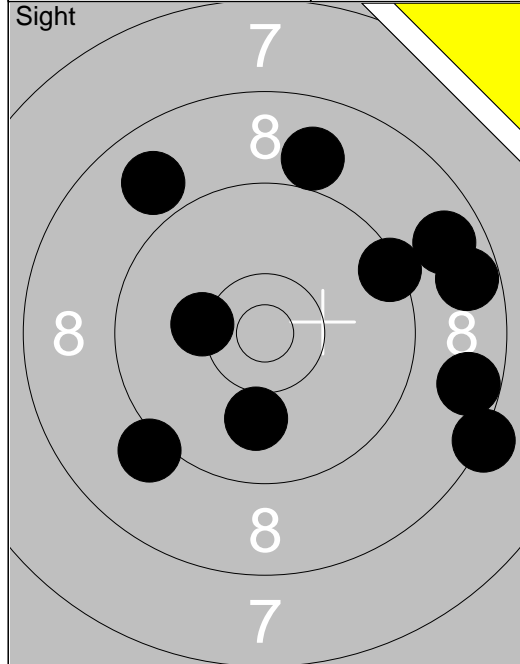

	11: 9.6 ↓
	12: 9.1 →
Series	18.0
Total	0.0

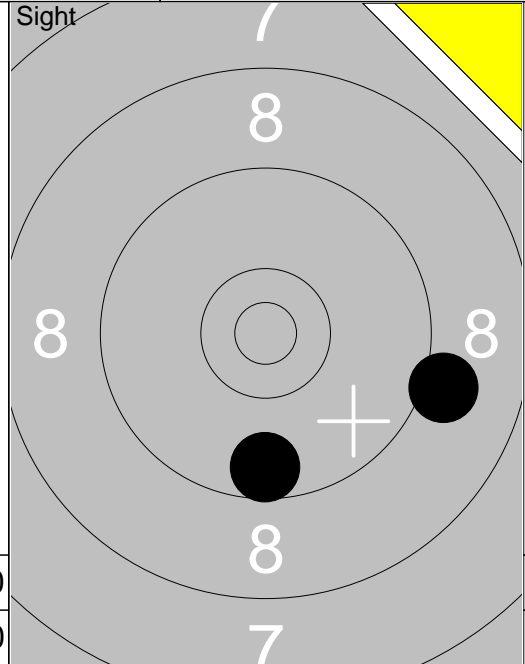

	6: *10.7 ↖
	7: *10.4 ↓
	8: 10.1 →
	9: 8.9 ←
	10: 9.5 →
Series	47.0
Total	90.0

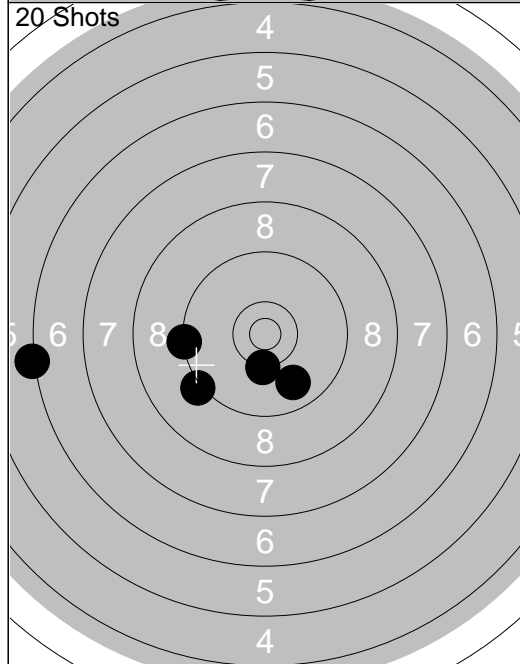

	11: 0.0 →
	12: 2.0 ←
	13: 6.1 ↓
	14: 5.9 →
	15: 8.3 ↓
Series	21.0
Total	111.0

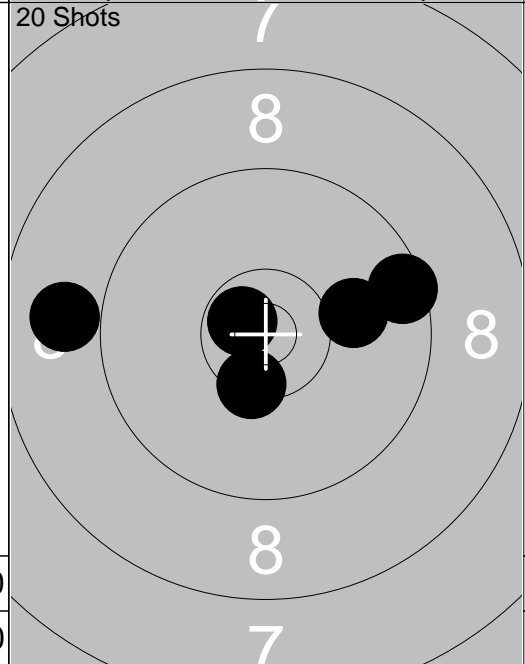

	16: 5.3 ←
	17: 10.2 ↗
	18: *10.3 ↓
	19: 7.9 ↓
	20: *10.4 →
Series	42.0
Total	153.0

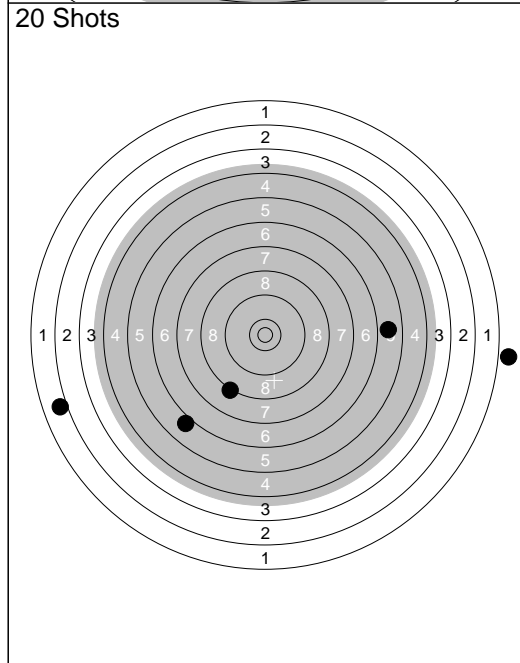

	16: 5.3 ←
	17: 10.2 ↗
	18: *10.3 ↓
	19: 7.9 ↓
	20: *10.4 →
Series	42.0
Total	153.0

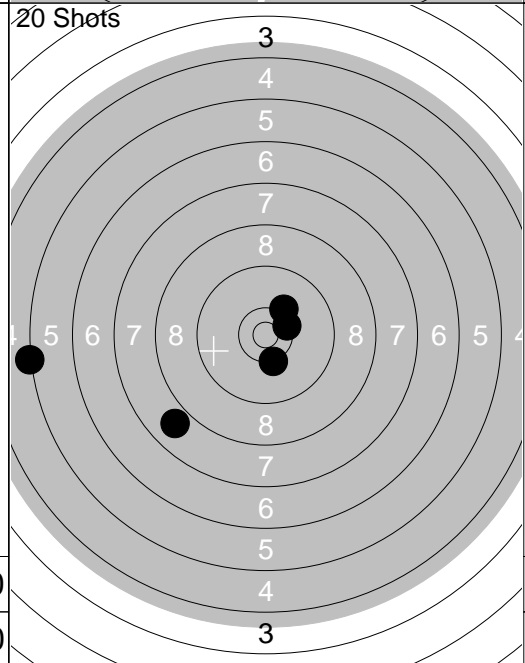

	16: 5.3 ←
	17: 10.2 ↗
	18: *10.3 ↓
	19: 7.9 ↓
	20: *10.4 →
Series	42.0
Total	153.0

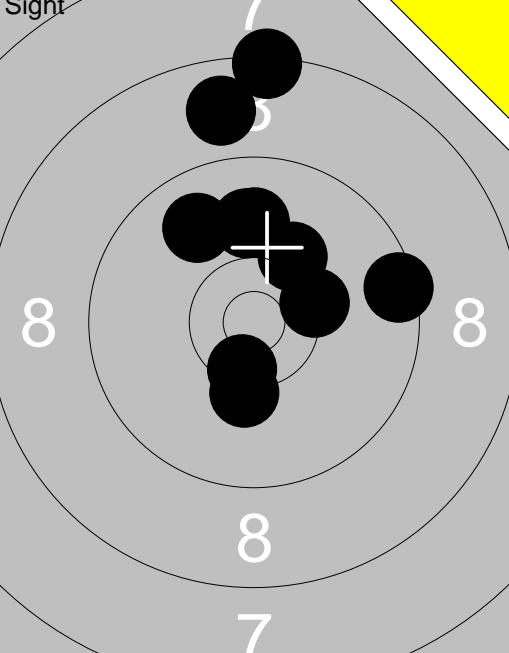
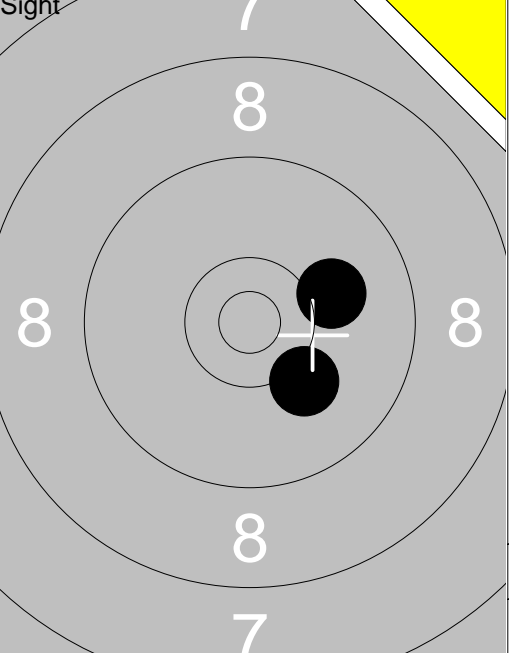
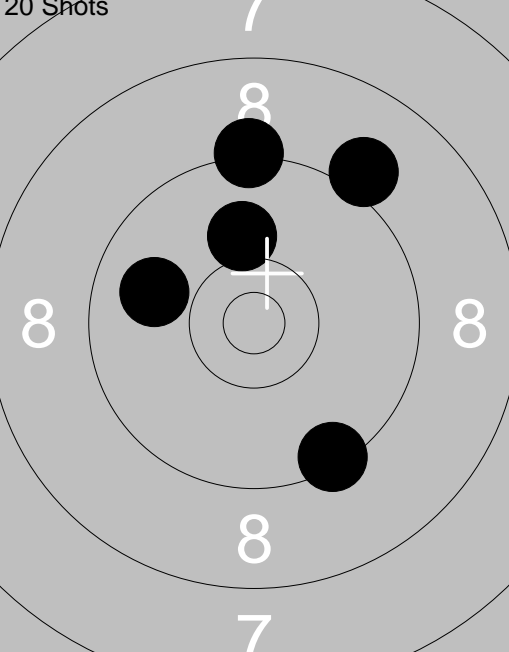
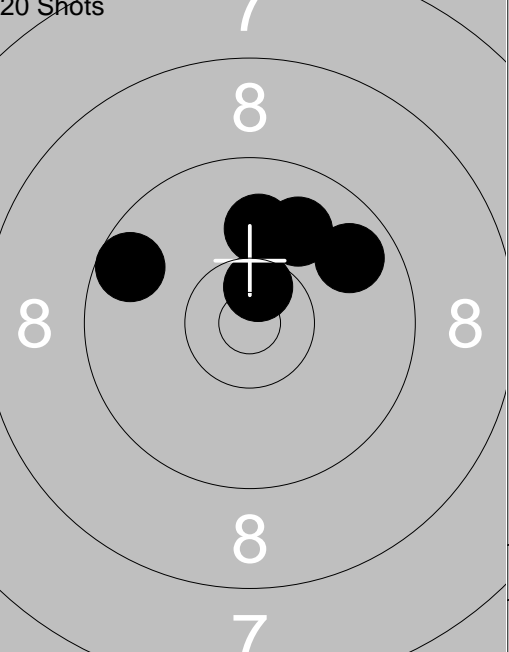
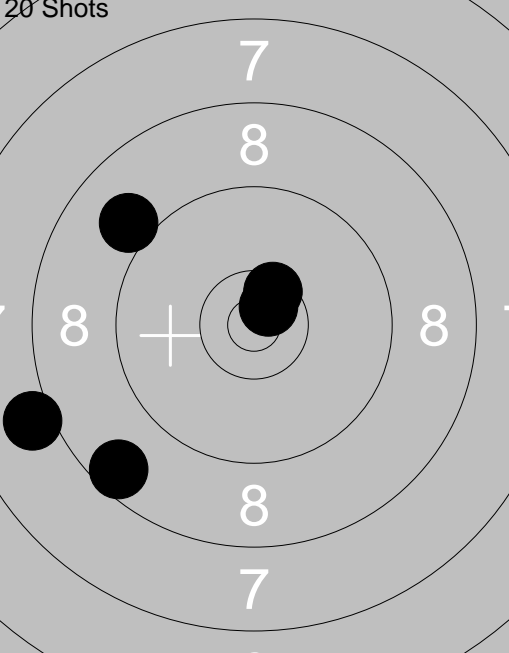
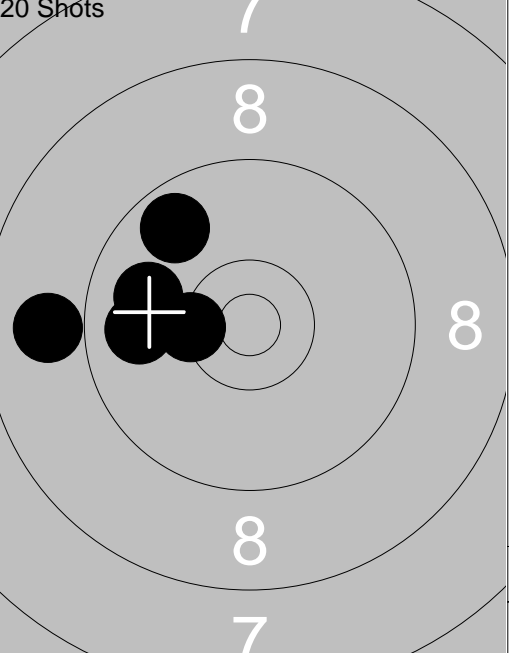
<p>Sight</p> 	<p>1: 8.8 ↑ 2: 10.0 ↑ 3: *10.5 ↓ 4: 9.8 ↖ 5: 10.2 ↓ 6: 10.0 ↑ 7: *10.3 → 8: 10.2 ↗ 9: 8.4 ↑ 10: 9.5 →</p> <p>Series 94.0 Total 0.0</p>	<p>Sight</p> 	<p>11: 10.1 ↘ 12: 10.1 →</p> <p>Series 20.0 Total 0.0</p>
<p>20 Shots</p> 	<p>1: 10.1 ↑ 2: 9.3 ↑ 3: 9.9 ← 4: 9.1 ↗ 5: 9.4 ↓</p> <p>Series 46.0 Total 46.0</p>	<p>20 Shots</p> 	<p>6: 10.0 ↑ 7: 9.6 ↖ 8: *10.6 ↗ 9: 9.9 ↗ 10: 9.8 ↗</p> <p>Series 47.0 Total 93.0</p>
<p>20 Shots</p> 	<p>11: *10.7 ↗ 12: 8.6 ↘ 13: 9.0 ↖ 14: 8.1 ← 15: *10.5 ↗</p> <p>Series 45.0 Total 138.0</p>	<p>20 Shots</p> 	<p>16: 9.8 ← 17: 8.9 ← 18: 9.9 ← 19: *10.4 ← 20: 9.7 ↖</p> <p>Series 45.0 Total 183.0</p>

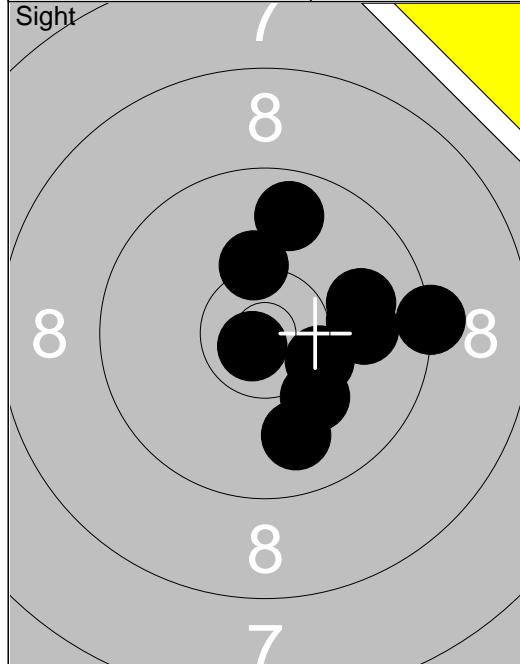

1:	*10.3	↘
2:	10.3	↑
3:	10.1	↘
4:	10.0	→
5:	9.3	→
6:	*10.8	↘
7:	9.9	↓
8:	9.8	↑
9:	10.0	→
10:	9.9	→
Series		96.0
Total		0.0

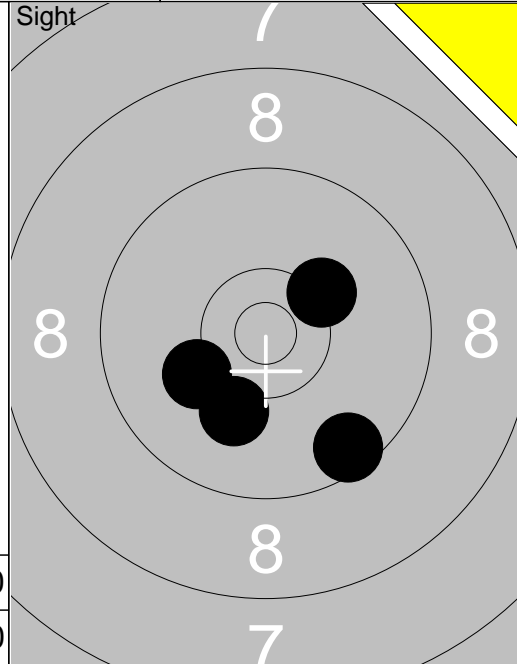

11:	10.2	↙
12:	9.5	↘
13:	10.3	↗
14:	10.1	↘
Series		39.0
Total		0.0

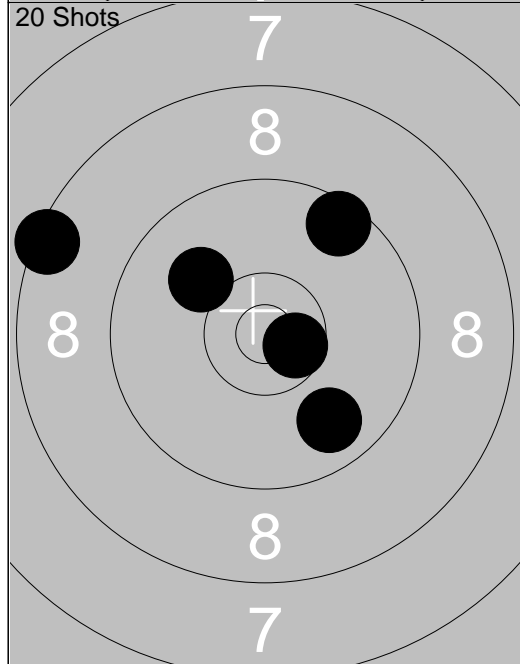

1:	9.8	↘
2:	10.1	↖
3:	9.5	↗
4:	*10.6	→
5:	8.4	↖
Series		46.0
Total		46.0

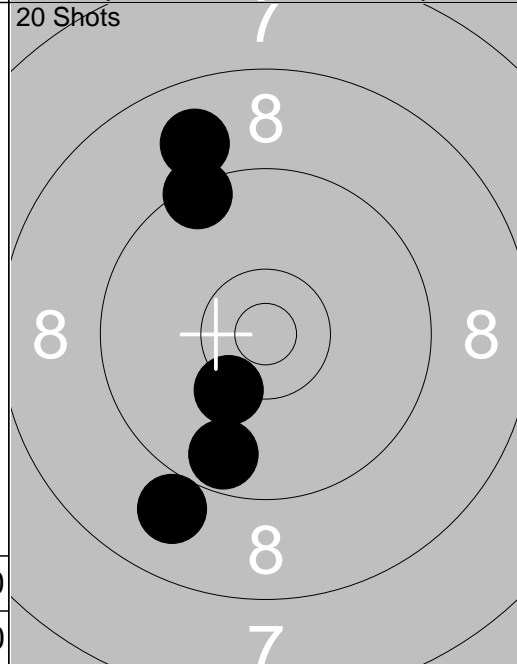

6:	9.7	↘
7:	9.0	↘
8:	10.3	↘
9:	9.4	↖
10:	8.9	↖
Series		45.0
Total		91.0

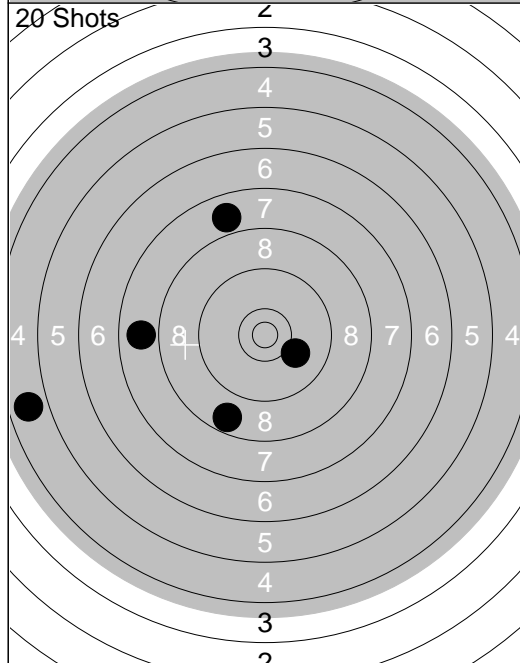

11:	7.9	↖
12:	10.1	↘
13:	7.9	↑
14:	4.8	↖
15:	8.7	↘
Series		36.0
Total		127.0

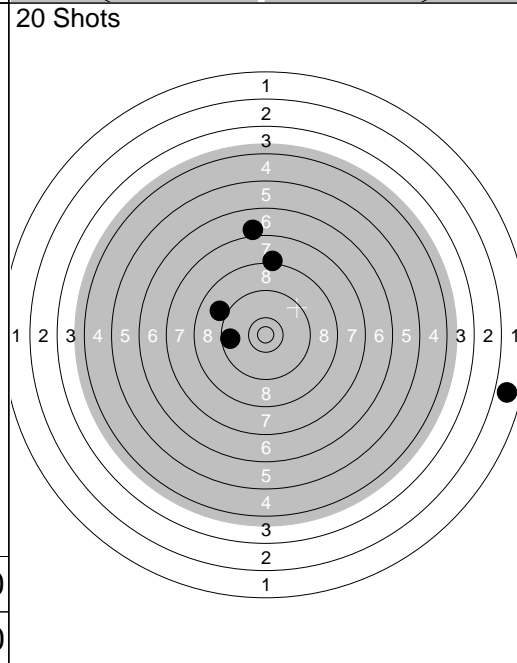

16:	7.1	↑
17:	1.9	→
18:	9.6	↖
19:	9.0	↖
20:	8.2	↑
Series		34.0
Total		161.0

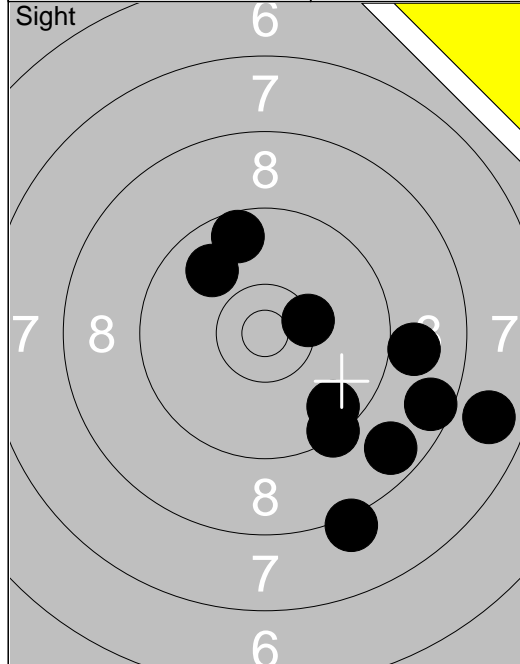

1:	9.6	↘
2:	7.8	→
3:	8.2	↘
4:	*10.4	→
5:	9.4	↘
6:	8.7	↘
7:	8.6	↘
8:	9.9	↗
9:	9.6	↗
10:	9.0	→
Series		86.0
Total		0.0

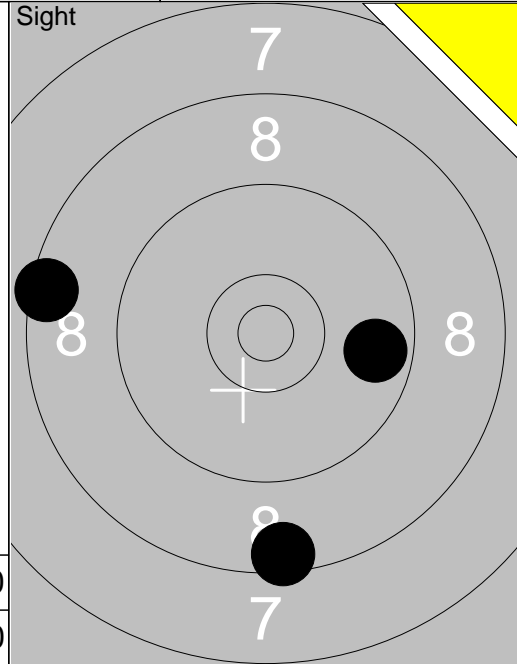

11:	9.7	→
12:	8.5	←
13:	8.5	↓
Series		25.0
Total		0.0

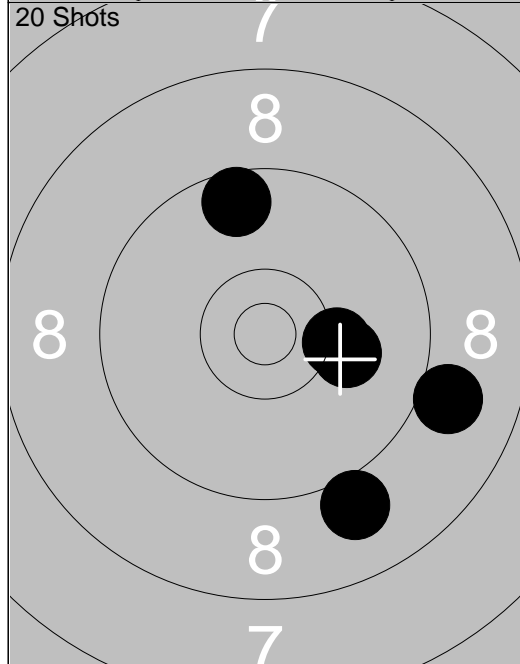

1:	10.2	→
2:	10.1	→
3:	9.6	↑
4:	9.0	↘
5:	9.0	↘
Series		47.0
Total		47.0

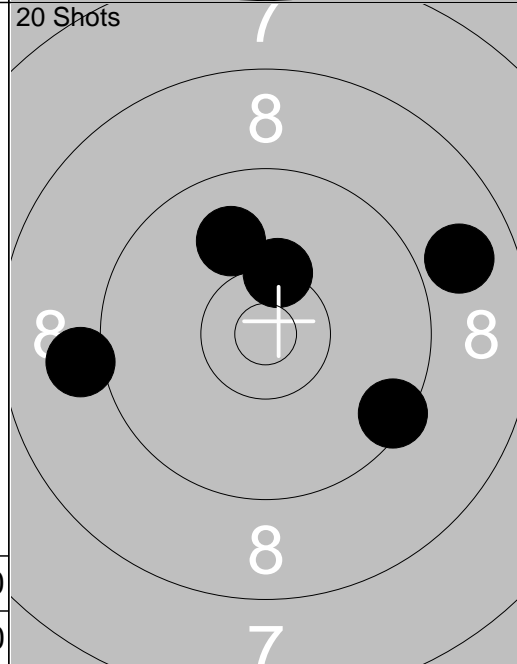

6:	10.0	↖
7:	9.1	←
8:	8.9	↗
9:	9.5	↘
10:	*10.3	↗
Series		46.0
Total		93.0

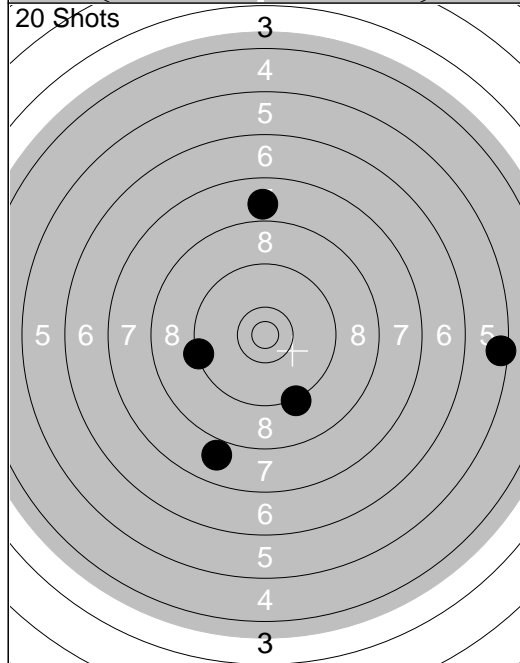

11:	9.3	↘
12:	5.5	→
13:	7.9	↘
14:	9.4	←
15:	7.9	↑
Series		37.0
Total		130.0

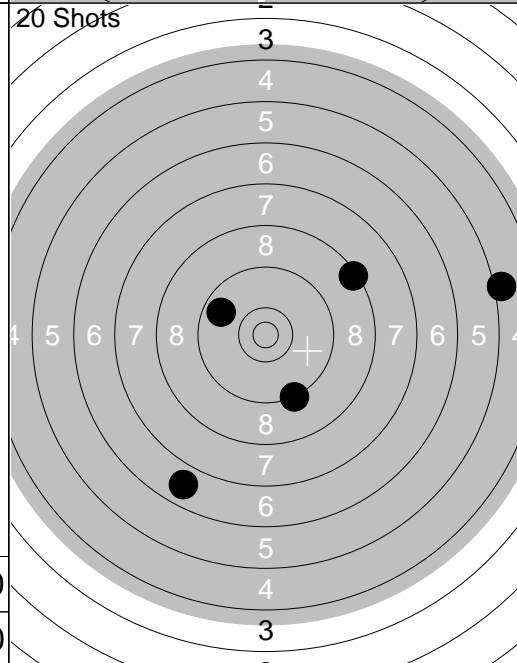

16:	5.1	→
17:	6.8	↘
18:	9.3	↘
19:	9.7	↖
20:	8.4	↗
Series		37.0
Total		167.0

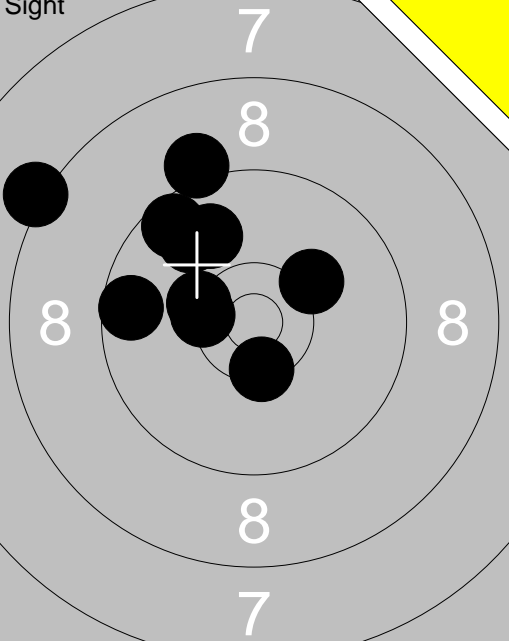
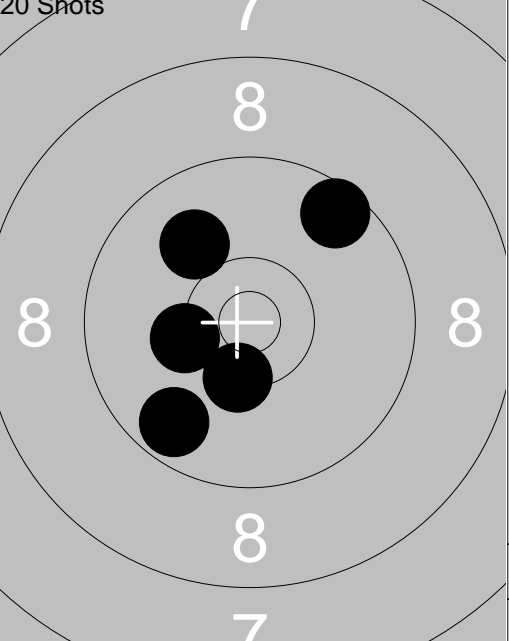
<p>Sight</p> 	<p>1: 8.2 ↖</p> <p>2: *10.3 ↖</p> <p>3: *10.4 ↓</p> <p>4: 9.6 ↗</p> <p>5: 9.6 ←</p> <p>6: 9.1 ↗</p> <p>7: 10.2 ↗</p> <p>8: 9.9 ↗</p> <p>9: 9.8 ↗</p> <p>10: *10.4 ←</p>	<p>20 Shots</p> 	<p>1: *10.4 ↓</p> <p>2: 10.3 ←</p> <p>3: 9.7 ↘</p> <p>4: 9.6 ↗</p> <p>5: 10.0 ↖</p>
Series 93.0		Series 48.0	
Total 0.0		Total 48.0	

<p>20 Shots</p> 	<p>6: *10.4 →</p> <p>7: *10.4 ←</p> <p>8: *10.5 →</p> <p>9: 9.9 ↑</p> <p>10: 9.6 ↓</p>	<p>20 Shots</p> 	<p>11: 6.2 ↗</p> <p>12: 9.3 ←</p> <p>13: 8.2 ↗</p> <p>14: 4.4 ↓</p> <p>15: 7.1 ↖</p>
Series 48.0		Series 34.0	
Total 96.0		Total 130.0	

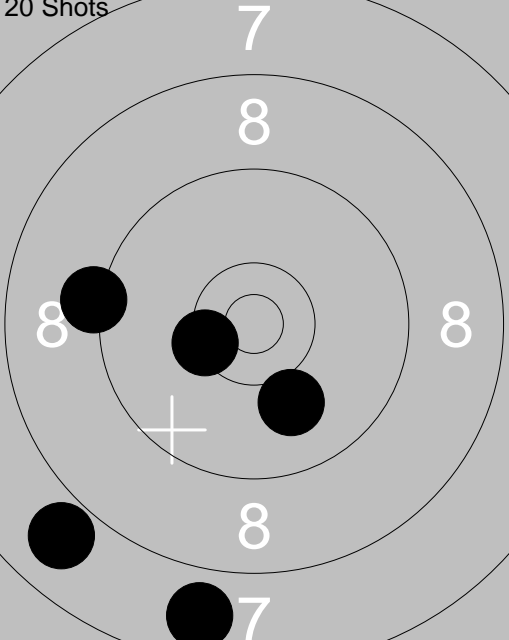
<p>20 Shots</p> 	<p>16: 9.2 ←</p> <p>17: *10.4 ←</p> <p>18: 7.8 ↓</p> <p>19: 10.0 ↓</p> <p>20: 7.9 ↘</p>		
Series 43.0			
Total 173.0			

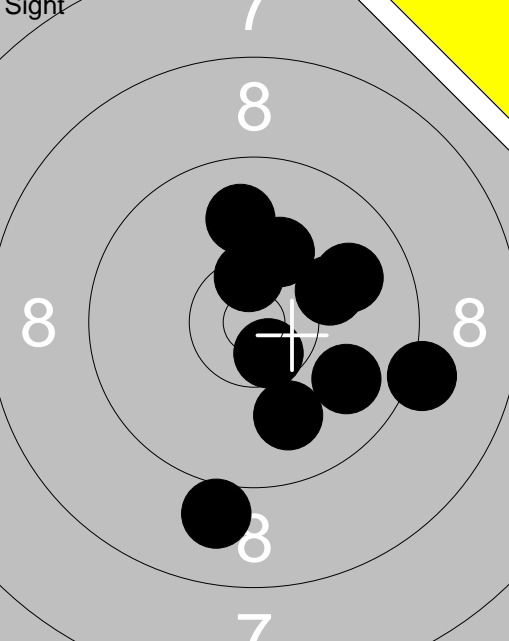
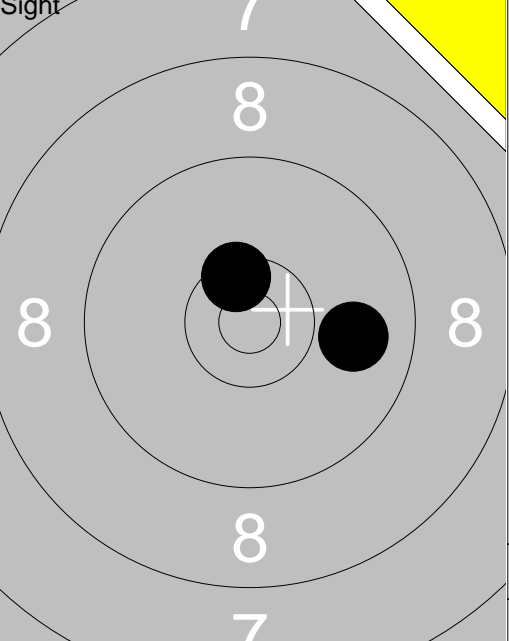
 <p>Sight</p>	<p>1: 9.0 ↓</p> <p>2: *10.5↑</p> <p>3: *10.6↓</p> <p>4: 9.2 →</p> <p>5: 9.9 →</p> <p>6: 10.2 ↑</p> <p>7: 9.9 ↑</p> <p>8: 10.1 →</p> <p>9: 10.0 ↓</p> <p>10: 9.9 →</p>	 <p>Sight</p>	<p>11: *10.5↑</p> <p>12: 9.9 →</p>
Series 95.0		Series 19.0	
Total 0.0		Total 0.0	

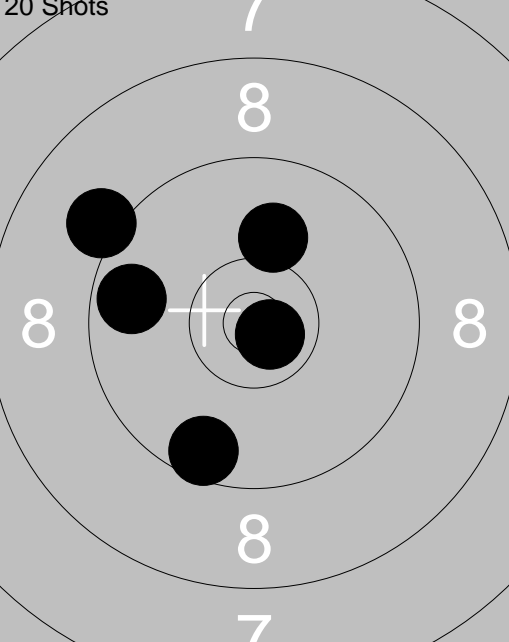
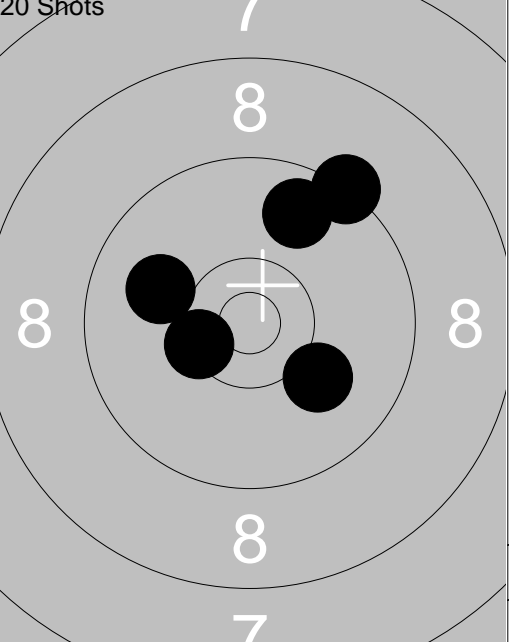
 <p>20 Shots</p>	<p>1: 9.6 ↓</p> <p>2: 10.1 ↑</p> <p>3: 9.1 ↖</p> <p>4: *10.8↘</p> <p>5: 9.7 ←</p>	 <p>20 Shots</p>	<p>6: 10.0 ↖</p> <p>7: 9.3 ↗</p> <p>8: 9.8 ↑</p> <p>9: 10.1 ↘</p> <p>10: *10.4↙</p>
Series 47.0		Series 48.0	
Total 47.0		Total 95.0	

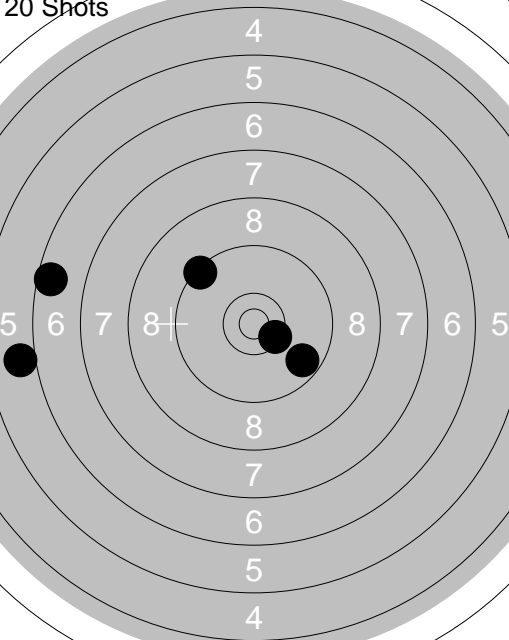
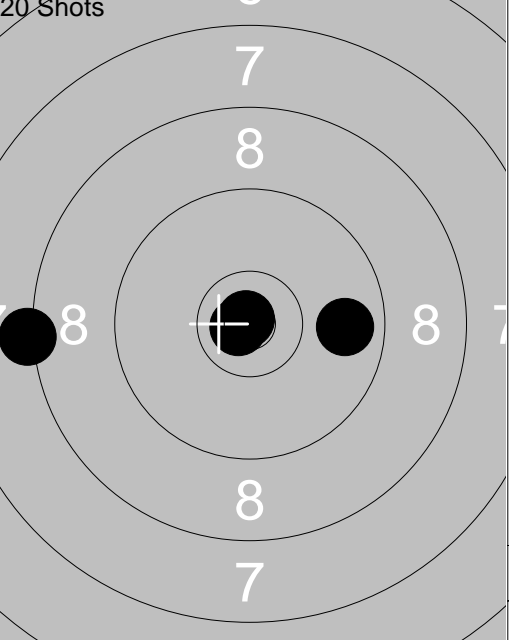
 <p>20 Shots</p>	<p>11: 9.7 ↘</p> <p>12: 6.0 ←</p> <p>13: 6.6 ←</p> <p>14: *10.4↘</p> <p>15: 9.4 ↗</p>	 <p>20 Shots</p>	<p>16: 8.2 ←</p> <p>17: *10.9↖</p> <p>18: 9.8 →</p> <p>19: *10.8↙</p> <p>20: 0.0</p>
Series 40.0		Series 37.0	
Total 135.0		Total 172.0	

	1: 10.1 → 2: 9.9 ↓ 3: *10.3 → 4: 9.8 ↖ 5: 9.6 ← 6: 9.8 ↗ 7: 10.3 → 8: 9.8 ↗ 9: 9.8 ↗ 10: 9.9 ↓		11: *10.6 →
	Series 93.0		Series 10.0
	Total 0.0		Total 0.0

	1: 9.7 → 2: 10.0 ↗ 3: *10.4 ← 4: 10.0 ↖ 5: *10.6 ↘		6: *10.4 ← 7: *10.3 → 8: 9.9 ↗ 9: 10.0 ↓ 10: 9.7 ←
	Series 49.0		Series 48.0
	Total 49.0		Total 97.0

	11: 9.0 ↓ 12: 9.0 ↓ 13: 8.7 ↓ 14: 8.9 ↓ 15: 8.7 ↗		16: 8.4 ↗ 17: 8.5 ↖ 18: 8.3 → 19: 7.9 ← 20: *10.7 →
	Series 42.0		Series 41.0
	Total 139.0		Total 180.0

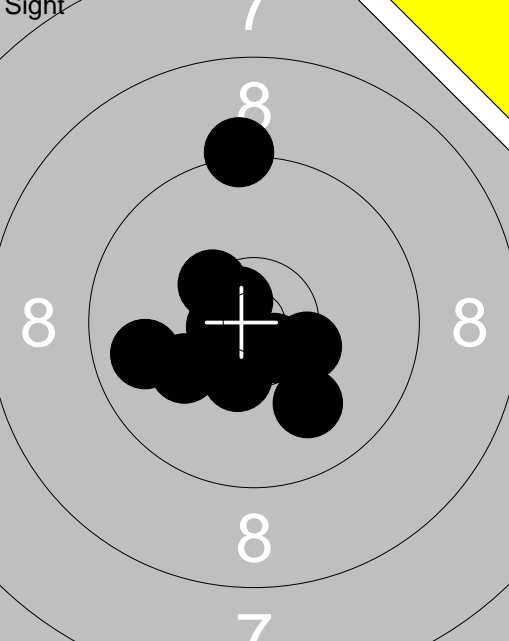
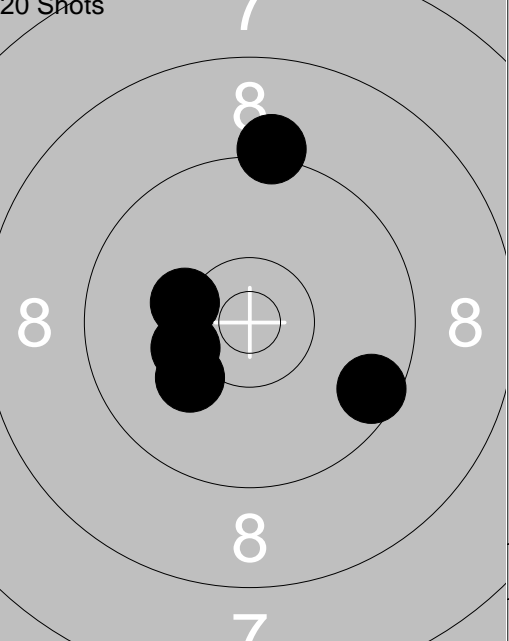
	<p>1: *10.6 ↘</p> <p>2: *10.4 ↓</p> <p>3: 10.1 ↙</p> <p>4: *10.6 ↙</p> <p>5: *10.4 ↗</p> <p>6: 10.0 ↓</p> <p>7: 9.2 ↑</p> <p>8: *10.4 →</p> <p>9: *10.7 ↗</p> <p>10: 9.8 ←</p>	<p>20 Shots</p> 	<p>1: 9.6 →</p> <p>2: 10.3 ↙</p> <p>3: 9.2 ↑</p> <p>4: 10.1 ↙</p> <p>5: 10.3 ↙</p>
Series 98.0		Series 48.0	
Total 0.0		Total 48.0	

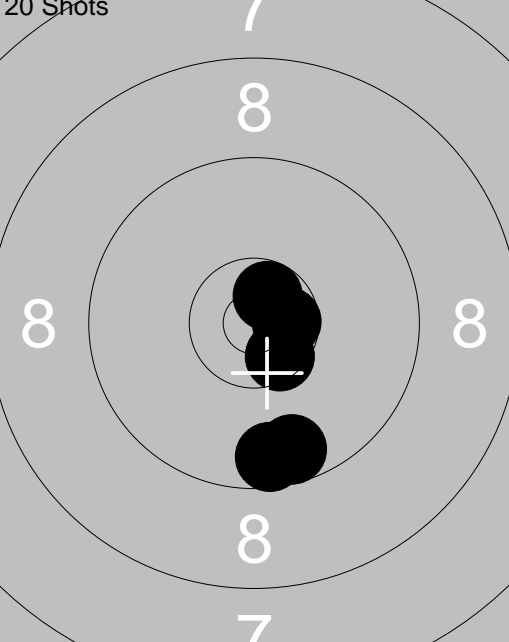
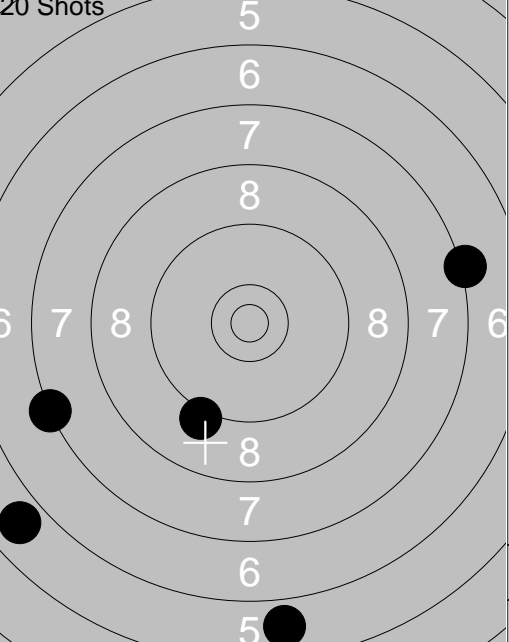
<p>20 Shots</p> 	<p>6: *10.6 →</p> <p>7: 9.6 ↓</p> <p>8: 9.6 ↓</p> <p>9: *10.6 ↗</p> <p>10: *10.5 ↘</p>	<p>20 Shots</p> 	<p>11: 9.2 ↓</p> <p>12: 7.3 ↙</p> <p>13: 5.9 ↙</p> <p>14: 5.9 ↓</p> <p>15: 7.2 →</p>
Series 48.0		Series 33.0	
Total 96.0		Total 129.0	

<p>20 Shots</p> 	<p>16: 9.3 →</p> <p>17: 8.7 ↓</p> <p>18: 8.7 ↓</p> <p>19: 9.0 →</p> <p>20: 7.3 →</p>		
Series 41.0			
Total 170.0			

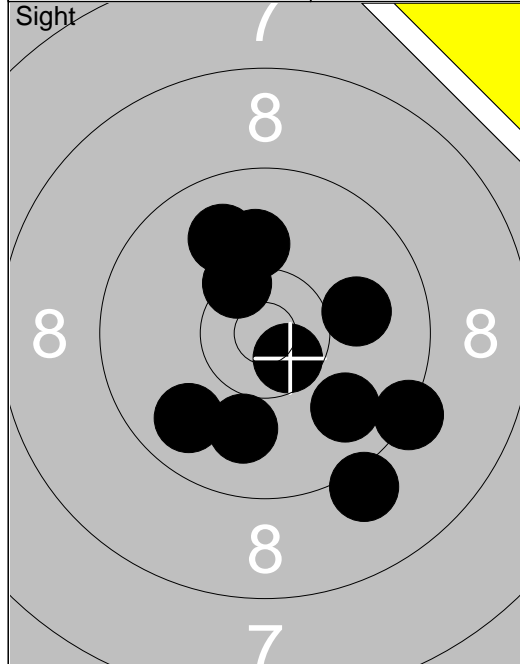

1:	9.1	↘
2:	9.9	↘
3:	9.3	↘
4:	10.1	↑
5:	9.8	↙
6:	10.0	↓
7:	*10.4	↙
8:	9.9	↑
9:	10.0	→
10:	*10.6	↘
Series	95.0	
Total	0.0	

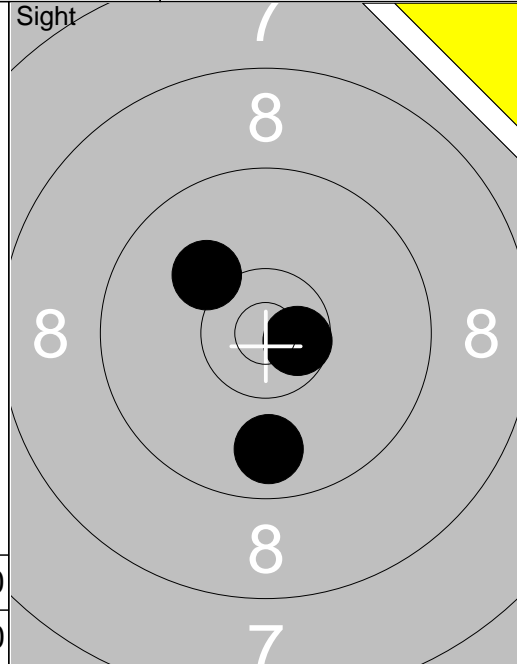

11:	*10.6	→
12:	9.8	↓
13:	10.1	↙
Series	29.0	
Total	0.0	

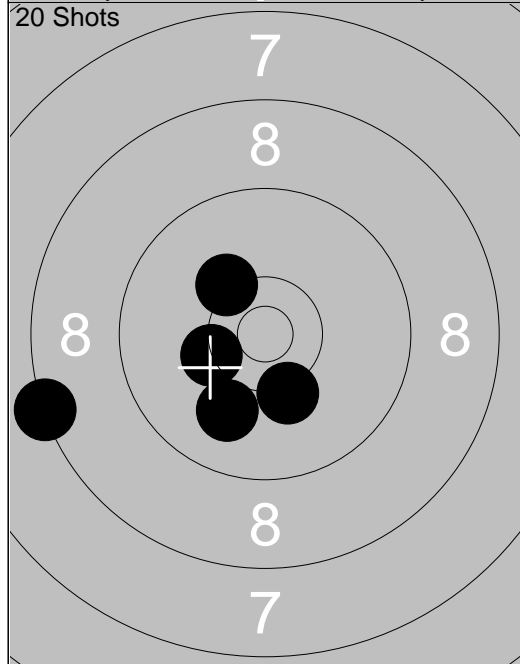

1:	10.2	↙
2:	8.3	←
3:	10.2	↓
4:	10.0	↓
5:	*10.3	↙
Series	48.0	
Total	48.0	

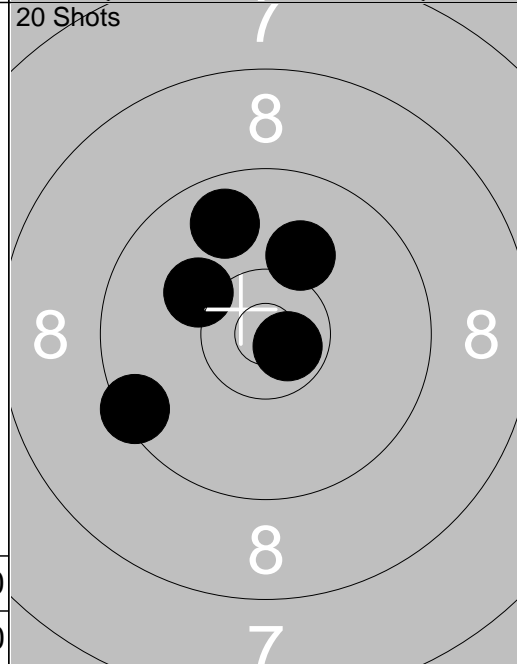

6:	10.2	↙
7:	10.1	↑
8:	*10.7	↘
9:	9.4	↙
10:	9.8	↑
Series	48.0	
Total	96.0	

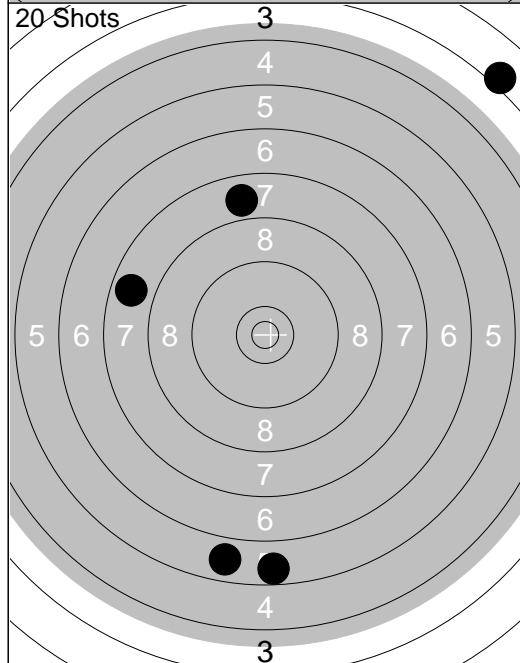

11:	3.1	↗
12:	7.8	←
13:	7.9	↑
14:	5.7	↓
15:	5.8	↓
Series	27.0	
Total	123.0	

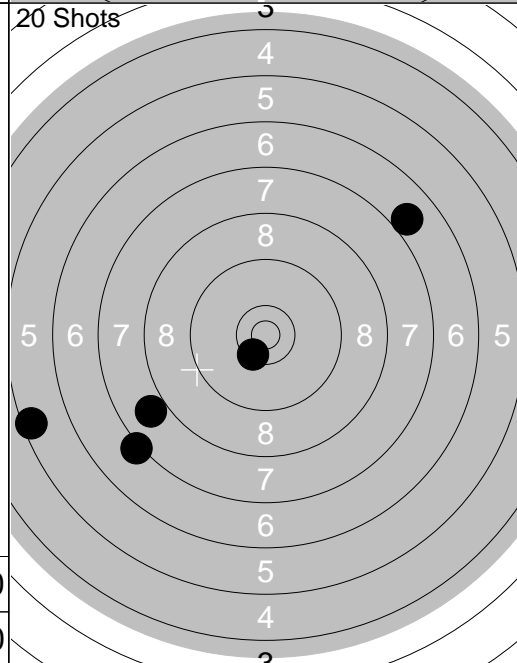

16:	7.0	↗
17:	5.5	←
18:	*10.4	↘
19:	7.9	↙
20:	7.2	↙
Series	36.0	
Total	159.0	

<p>Sight</p>	<p>1: 9.9 ↓ 2: 10.0 ↖ 3: *10.6 → 4: 9.1 ↑ 5: 9.6 ← 6: 10.2 ↑ 7: *10.3 ↗ 8: *10.5 ↖ 9: 9.5 ↘ 10: 9.9 ↑</p> <p>Series 95.0 Total 0.0</p>	<p>Sight</p>	<p>11: 10.1 ↖</p> <p>Series 10.0 Total 0.0</p>
<p>20 Shots</p>	<p>1: 9.8 ↖ 2: *10.6 ↗ 3: 9.9 ↗ 4: 9.8 ↗ 5: 9.0 ↑</p> <p>Series 46.0 Total 46.0</p>	<p>20 Shots</p>	<p>6: 9.7 ↘ 7: *10.8 ↘ 8: 9.9 ↖ 9: 10.1 ↗ 10: *10.6 →</p> <p>Series 48.0 Total 94.0</p>
<p>20 Shots</p>	<p>11: 8.9 ← 12: 10.2 ↑ 13: 8.5 ↓ 14: 9.2 ← 15: 7.8 ↘</p> <p>Series 42.0 Total 136.0</p>	<p>20 Shots</p>	<p>16: 10.2 ↖ 17: 9.7 ↗ 18: 9.1 ↓ 19: 7.6 ← 20: 10.0 →</p> <p>Series 45.0 Total 181.0</p>

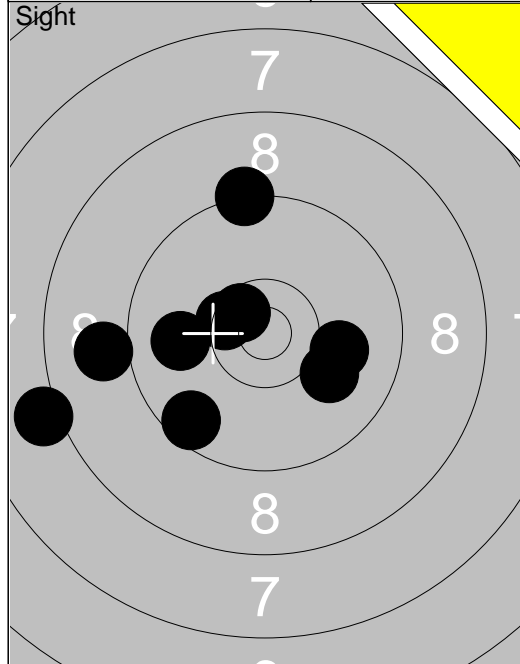

- 1: 10.0 →
- 2: 9.9 ←
- 3: 8.1 ←
- 4: 9.0 ←
- 5: 9.6 ↘
- 6: 9.3 ↑
- 7: 10.0 →
- 8: *10.6 ↘
- 9: *10.4 ↘

Series 84.0
Total 0.0

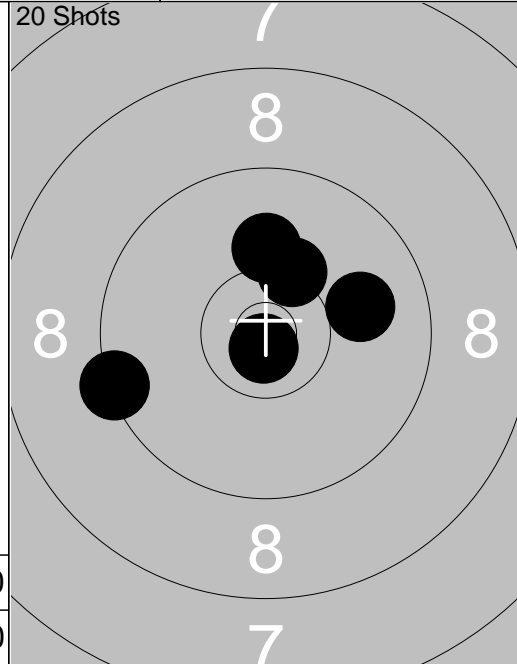

- 1: 9.4 ←
- 2: 10.3 ↗
- 3: *10.8 ↘
- 4: 10.1 ↑
- 5: 10.0 →

Series 49.0
Total 49.0

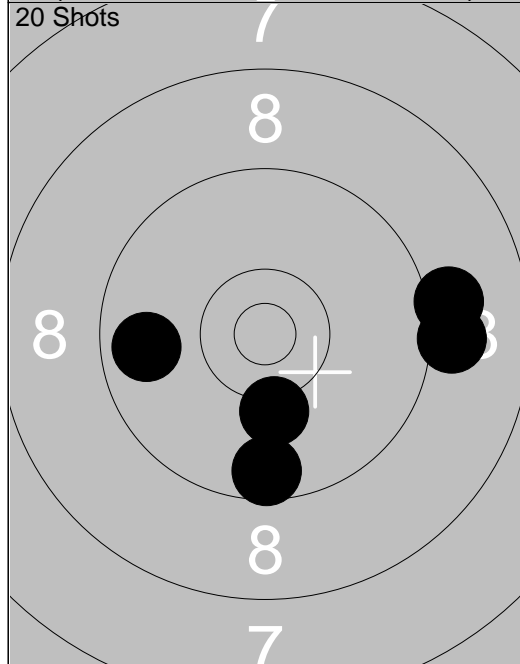

- 6: 9.1 →
- 7: 9.1 →
- 8: 9.6 ↓
- 9: 9.8 ←
- 10: 10.2 ↓

Series 46.0
Total 95.0

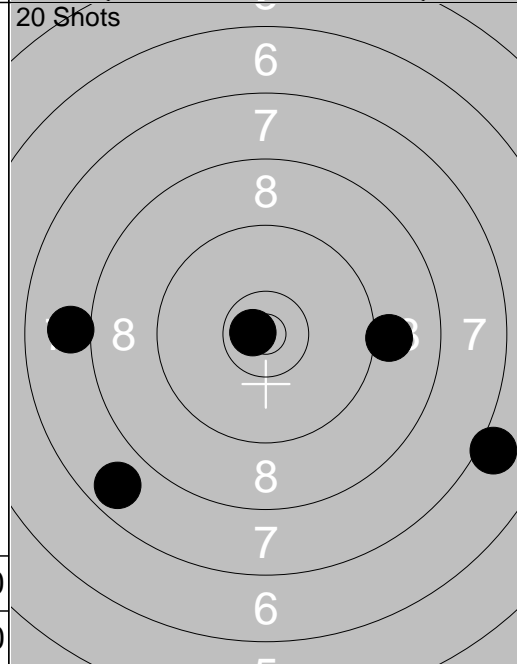

- 11: 7.7 ↘
- 12: 8.0 ←
- 13: 7.1 →
- 14: *10.8 ↘
- 15: 9.1 →

Series 41.0
Total 136.0

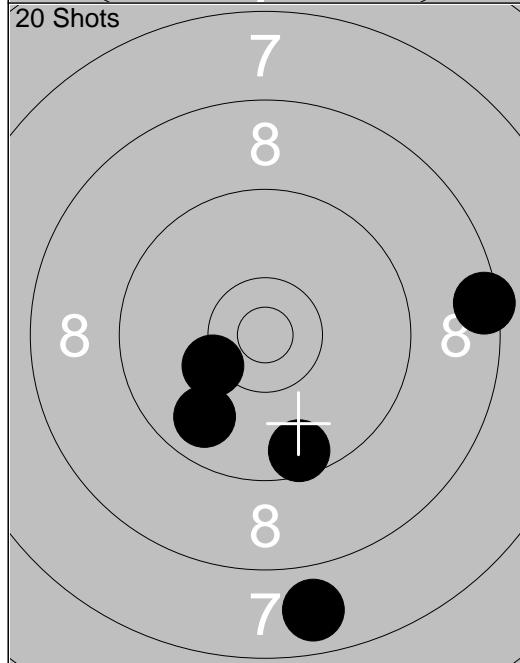

- 16: 7.8 ↓
- 17: 10.3 ↙
- 18: 8.4 →
- 19: 9.6 ↓
- 20: 9.8 ↘

Series 43.0
Total 179.0

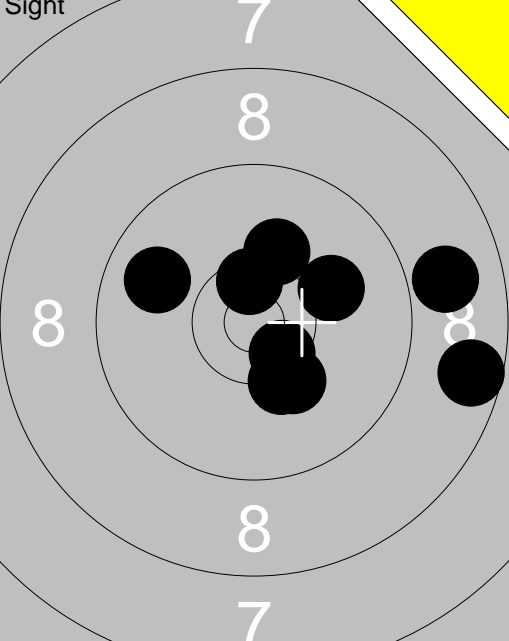
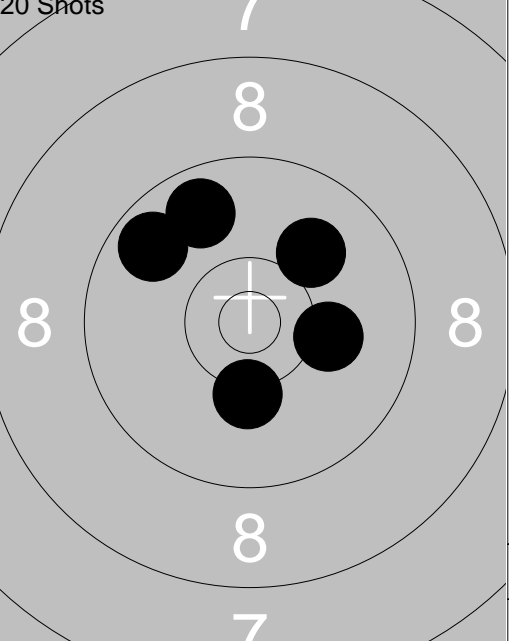
<p>Sight</p> 	<p>20 Shots</p> 	<p>1: 9.8 ↙ 2: *10.5 ↘ 3: 10.1 → 4: 8.9 → 5: *10.5 ↑ 6: 10.2 ↘ 7: 10.2 ↑ 8: 8.6 → 9: 10.3 ↘</p> <p>1: 10.2 → 2: 10.2 ↓ 3: 9.7 ↙ 4: 9.8 ↗ 5: 10.0 ↗</p>
Series 85.0	Series 48.0	
Total 0.0	Total 48.0	

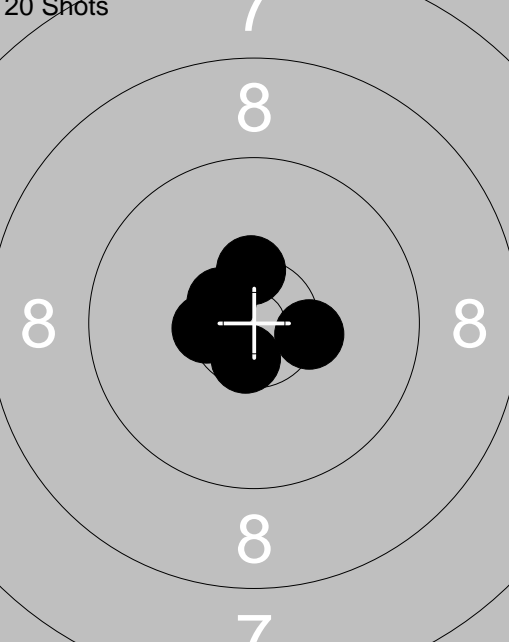
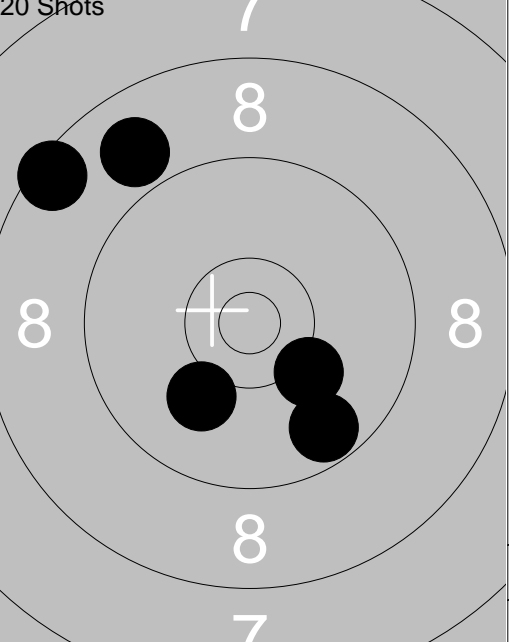
<p>20 Shots</p> 	<p>20 Shots</p> 	<p>6: *10.4 → 7: *10.6 ↘ 8: *10.5 ↙ 9: *10.4 ↑ 10: *10.6 ↙</p> <p>11: 8.9 ↗ 12: 10.2 ↘ 13: 8.5 ↗ 14: 9.7 ↘ 15: 10.1 ↘</p>
Series 50.0	Series 45.0	
Total 98.0	Total 143.0	

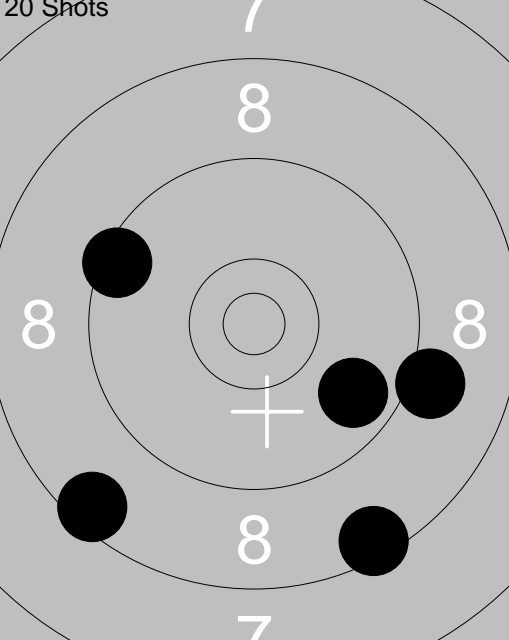
<p>20 Shots</p> 	<p>16: 8.5 ↘ 17: 9.5 ↙ 18: 9.1 → 19: 9.7 ↘ 20: 8.5 ↘</p>	
Series 43.0		
Total 186.0		

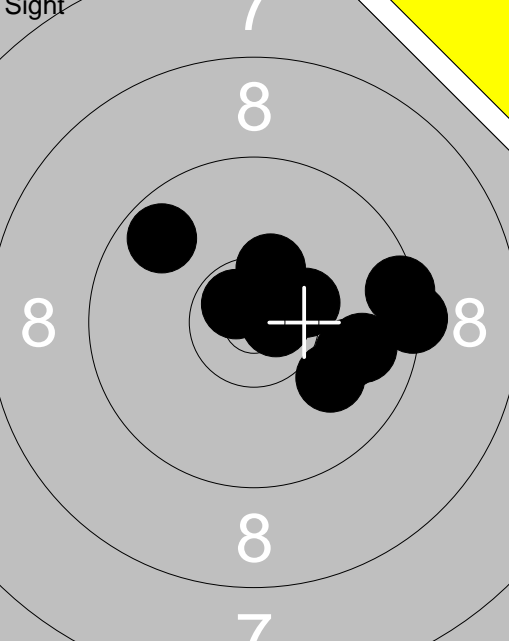
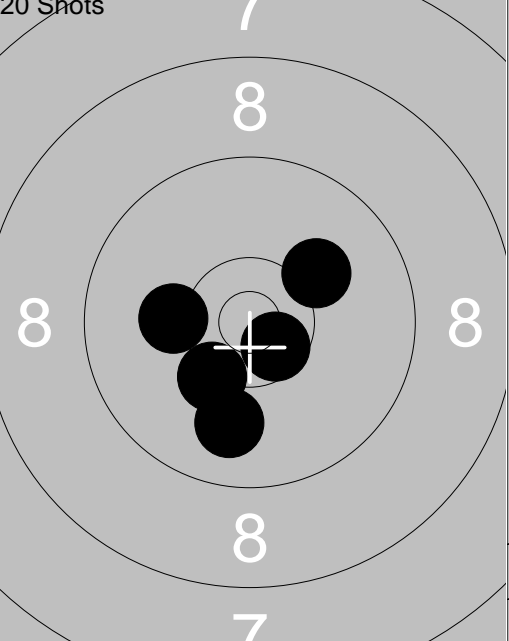
<p>Sight</p> 	<p>1: *10.7 →</p> <p>2: 9.4 →</p> <p>3: 9.5 →</p> <p>4: *10.4 ↑</p> <p>5: 9.7 ↖</p> <p>6: 9.8 →</p> <p>7: 10.0 ↘</p> <p>8: *10.7 ↖</p> <p>9: *10.4 →</p> <p>10: 10.0 →</p>	<p>20 Shots</p> 	<p>1: 10.1 ↗</p> <p>2: *10.3 ↘</p> <p>3: 10.2 ←</p> <p>4: 9.9 ↓</p> <p>5: *10.6 ↘</p>
<p>Series 96.0</p>		<p>Series 49.0</p>	
<p>Total 0.0</p>		<p>Total 49.0</p>	

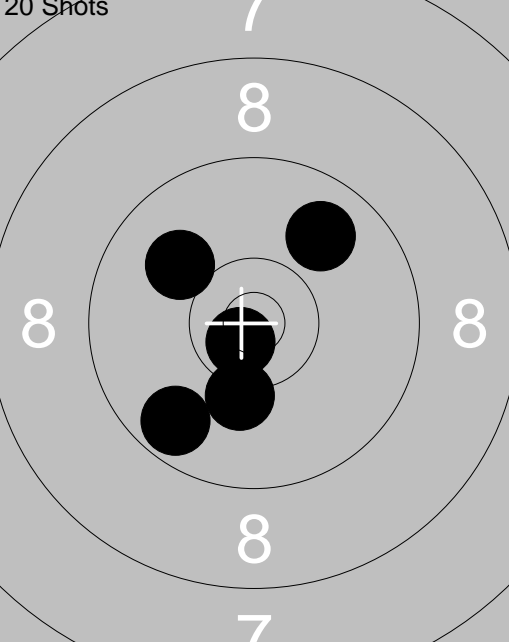
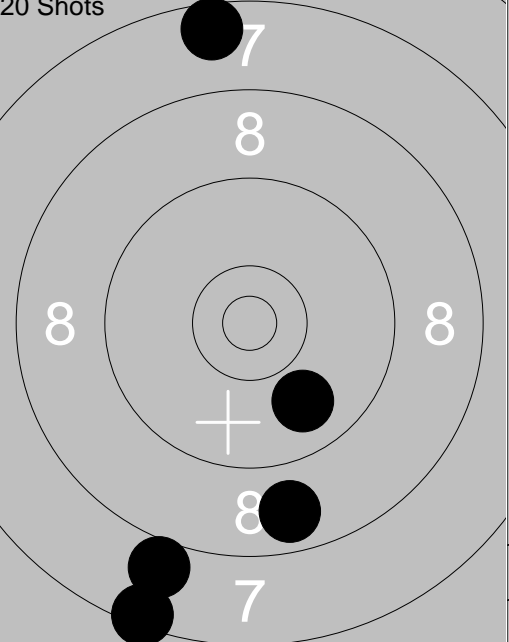
<p>20 Shots</p> 	<p>6: 10.2 ↓</p> <p>7: 9.9 ↗</p> <p>8: 10.0 ↖</p> <p>9: 9.7 ↓</p> <p>10: *10.7 ↘</p>	<p>20 Shots</p> 	<p>11: 7.6 ↑</p> <p>12: 9.9 ↘</p> <p>13: 8.8 ↓</p> <p>14: 8.0 ↓</p> <p>15: 7.4 ↓</p>
<p>Series 48.0</p>		<p>Series 39.0</p>	
<p>Total 97.0</p>		<p>Total 136.0</p>	

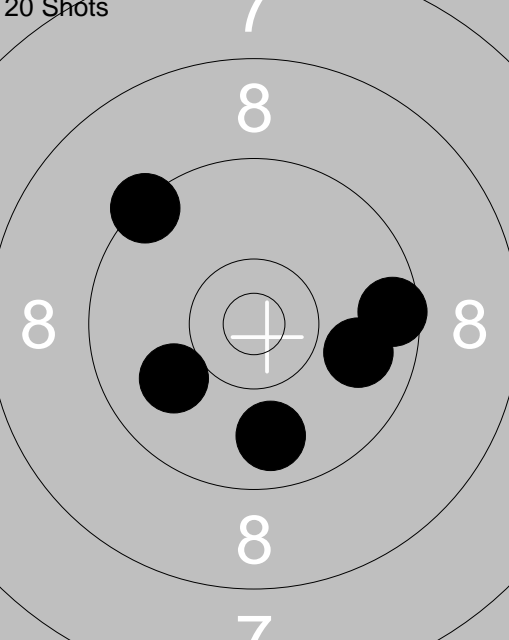
<p>20 Shots</p> 	<p>16: 10.0 ↙</p> <p>17: 9.8 ↓</p> <p>18: 9.4 ↖</p> <p>19: 9.6 →</p> <p>20: 9.9 →</p>		
<p>Series 46.0</p>			
<p>Total 182.0</p>			

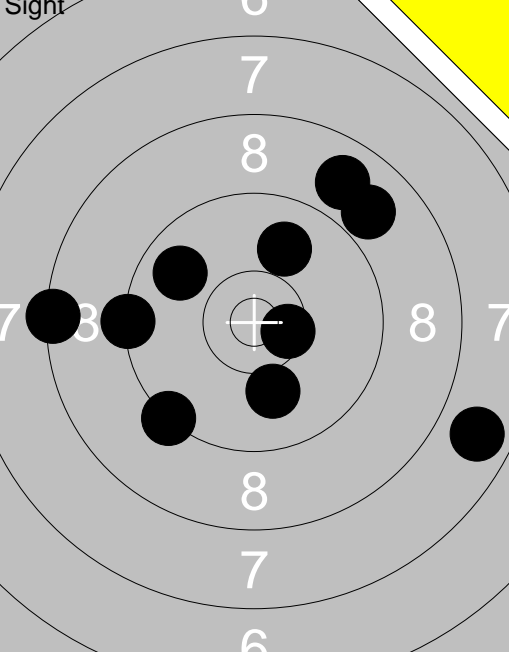
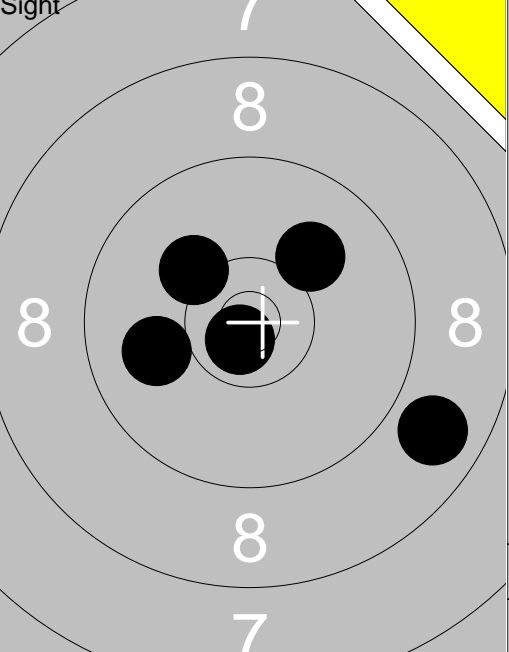
	<p>1: 9.3 ↙ 2: 9.8 ↖ 3: *10.5 → 4: 7.8 → 5: 9.3 ← 6: 10.0 ↓ 7: 8.9 ↗ 8: 8.4 ← 9: 9.9 ↑ 10: 8.8 ↗</p> <p>Series 87.0 Total 0.0</p>		<p>11: 10.0 ← 12: 8.8 → 13: *10.8 ↙ 14: 10.2 ↖ 15: 10.1 ↗</p> <p>Series 48.0 Total 0.0</p>
--	---	--	--

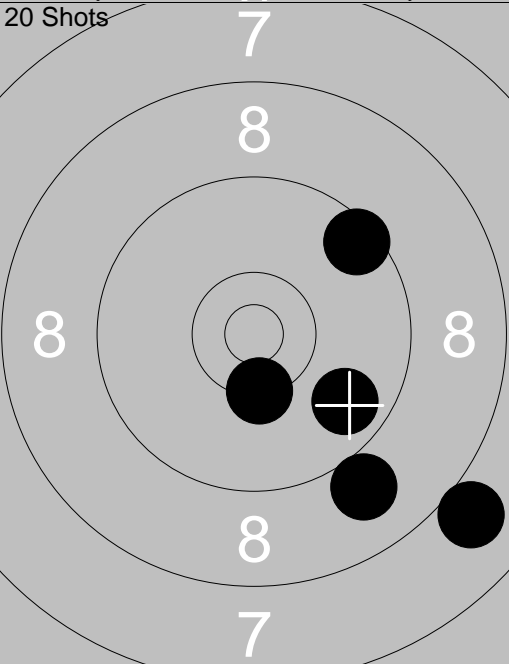
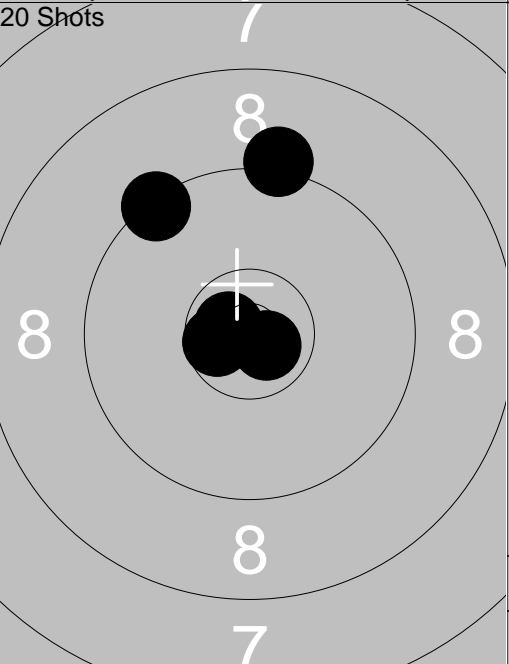
	<p>1: 8.0 → 2: 9.5 ↗ 3: 9.0 ↓ 4: 9.8 → 5: *10.4 ↓</p> <p>Series 45.0 Total 45.0</p>		<p>6: *10.6 ← 7: *10.7 ↖ 8: 9.4 ↖ 9: *10.7 → 10: 9.2 ↑</p> <p>Series 48.0 Total 93.0</p>
---	---	---	--

	<p>11: 3.2 ↗ 12: 5.0 ↓ 13: 6.9 ← 14: 6.2 ↓ 15: 7.8 ↓</p> <p>Series 27.0 Total 120.0</p>		<p>16: 9.5 → 17: 9.4 ↓ 18: 5.8 ↓ 19: 6.1 → 20: 6.1 →</p> <p>Series 35.0 Total 155.0</p>
--	---	--	---

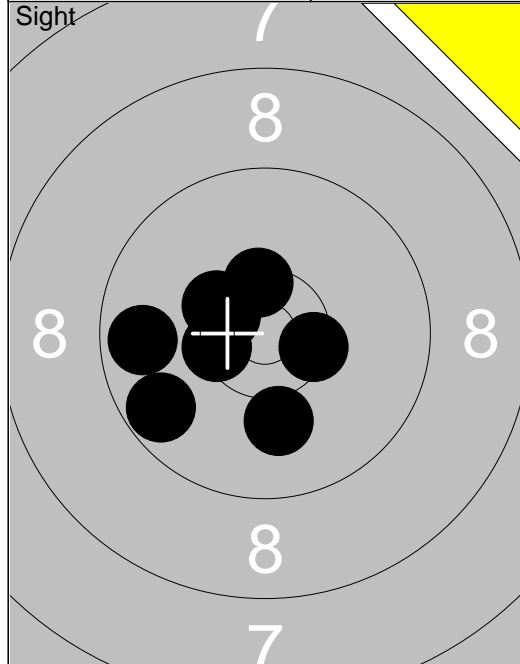

- 1: 9.7 ↙
- 2: *10.4 ↙
- 3: 10.1 ↓
- 4: *10.4 ↑
- 5: 9.7 ←
- 6: *10.4 ➔
- 7: *10.4 ↘
- 8: *10.5 ↘

Series 78.0
Total 0.0

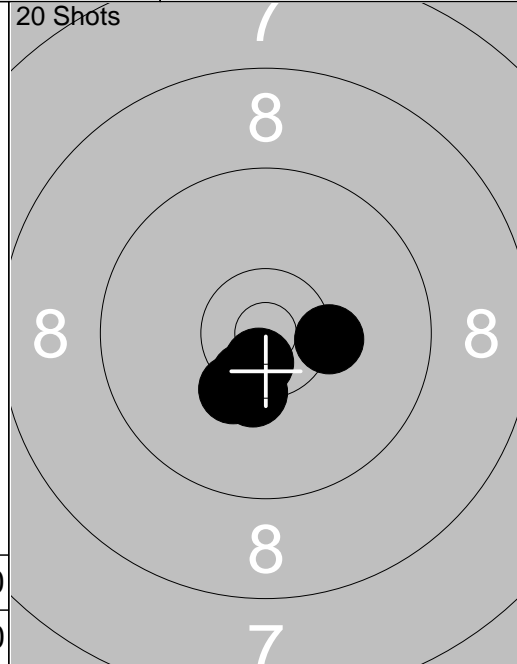

- 1: *10.3 ↓
- 2: *10.5 ↓
- 3: *10.3 ↓
- 4: *10.6 ↓
- 5: *10.3 ➔

Series 50.0
Total 50.0

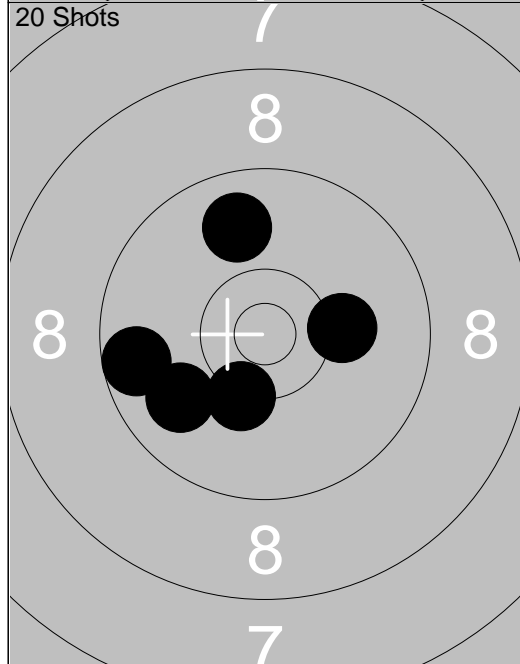

- 6: 10.2 ➔
- 7: 9.9 ↙
- 8: 9.8 ↑
- 9: 9.6 ←
- 10: *10.3 ↓

Series 47.0
Total 97.0

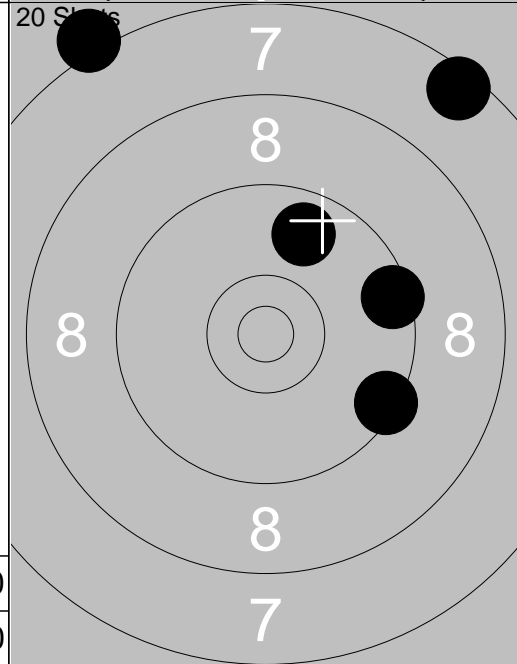

- 11: 7.2 ↖
- 12: 9.8 ↑
- 13: 7.5 ↗
- 14: 9.4 ➔
- 15: 9.5 ➔

Series 41.0
Total 138.0

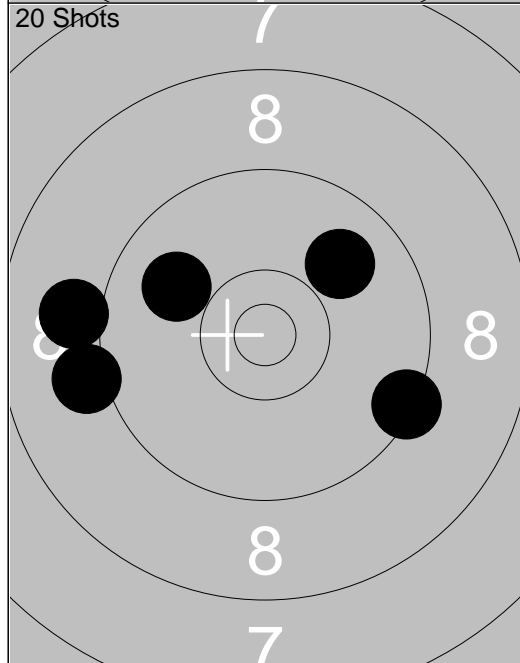

- 16: 9.9 ↗
- 17: 9.4 ➔
- 18: 9.9 ↖
- 19: 9.1 ←
- 20: 9.0 ←

Series 45.0
Total 183.0

<p>Sight</p>	<p>1: 8.4 ↘ 2: 9.8 → 3: 9.7 → 4: 9.9 ↘ 5: 9.8 → 6: 9.8 ← 7: 9.9 ↗ 8: *10.6 ↘ 9: 10.1 ↖ 10: 10.2 ←</p>	<p>Sight</p>
Series 92.0		Series 19.0
Total 0.0		Total 0.0

<p>20 Shots</p>	<p>1: 9.8 ↘ 2: 10.0 ↘ 3: 9.8 ↗ 4: 10.1 ← 5: 10.1 ↖</p>	<p>20 Shots</p>
Series 48.0		Series 46.0
Total 48.0		Total 94.0

<p>20 Shots</p>	<p>11: 8.3 → 12: 9.2 ↘ 13: 4.9 ↘ 14: 7.9 → 15: 8.9 ↗</p>	<p>20 Shots</p>
Series 36.0		Series 41.0
Total 130.0		Total 171.0

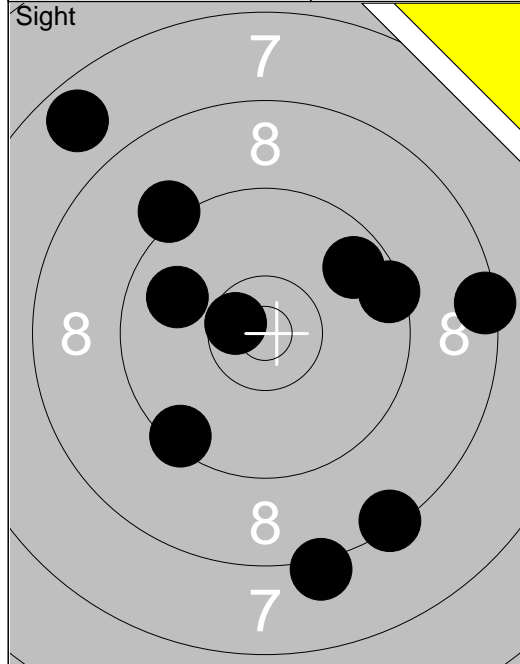

1: 7.7 ↗
2: 8.2 ↓
3: 8.4 ↓
4: 9.4 ↙
5: 9.2 ↗
6: 9.9 ↖
7: 8.4 →
8: 9.7 ↗
9: 9.5 →
10: *10.6 ↖
Series 86.0
Total 0.0

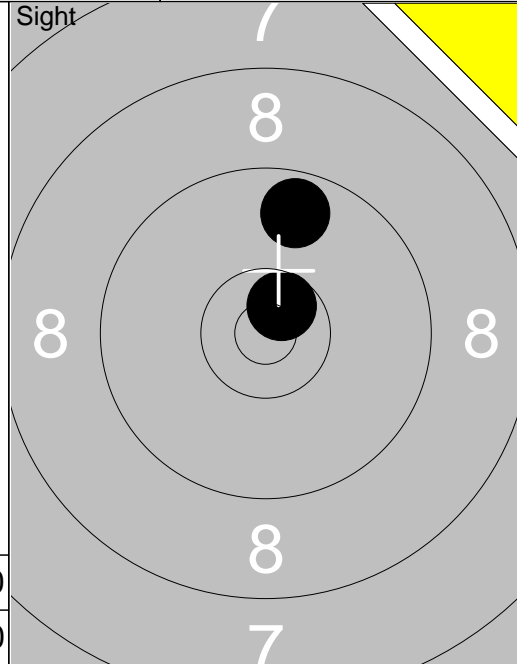

11: 9.7 ↗
12: *10.6 ↗
Series 19.0
Total 0.0

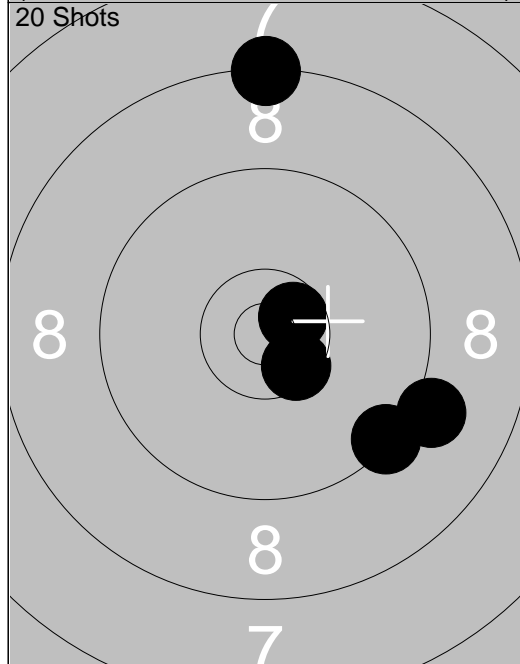

1: 9.4 ↘
2: 9.1 →
3: 8.3 ↑
4: *10.5 ↘
5: *10.6 ↗
Series 46.0
Total 46.0

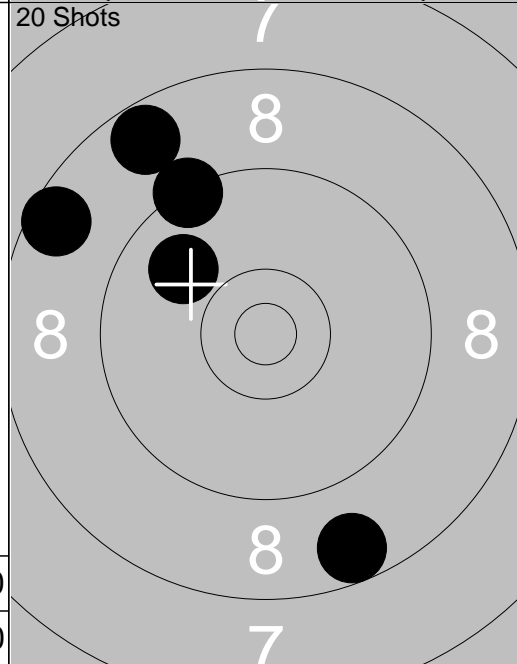

6: 8.7 ↗
7: 8.6 ↖
8: 9.3 ↗
9: 9.9 ↖
10: 8.6 ↓
Series 42.0
Total 88.0

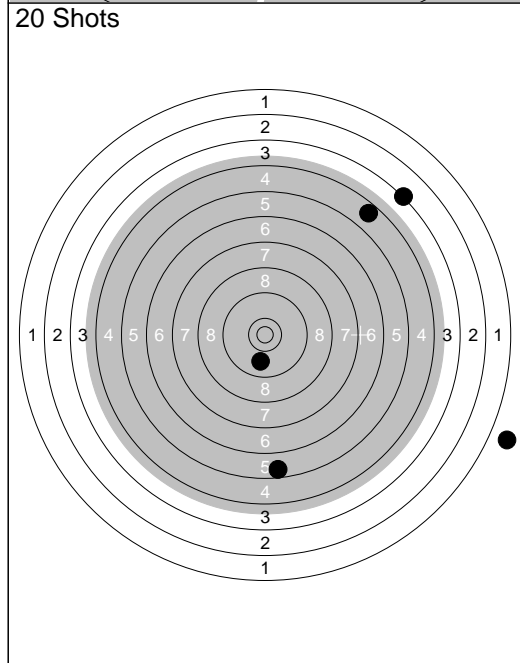

11: 4.7 ↗
12: 3.3 ↗
13: 0.0 →
14: 9.9 ↓
15: 5.6 ↓
Series 21.0
Total 109.0

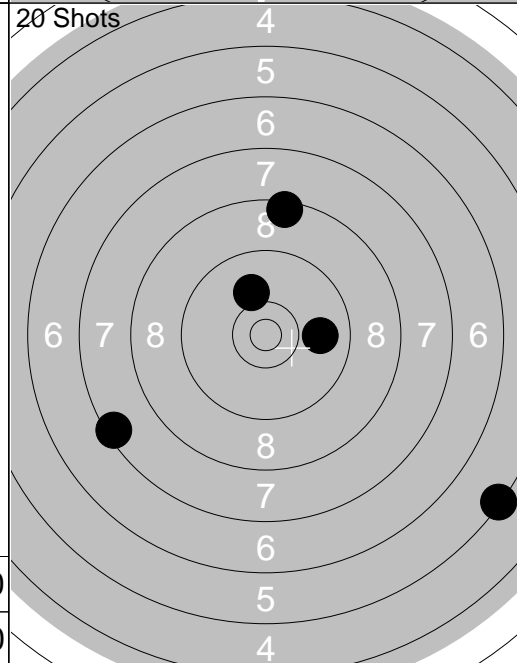

16: 9.9 →
17: 5.3 ↘
18: 7.5 ↖
19: 8.5 ↑
20: 10.1 ↖
Series 39.0
Total 148.0

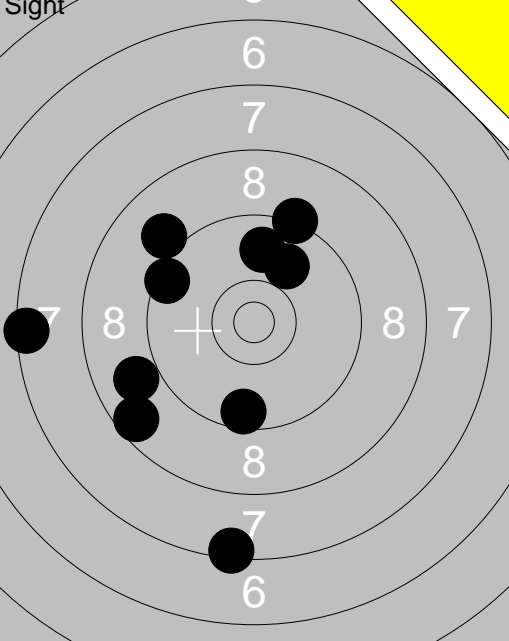
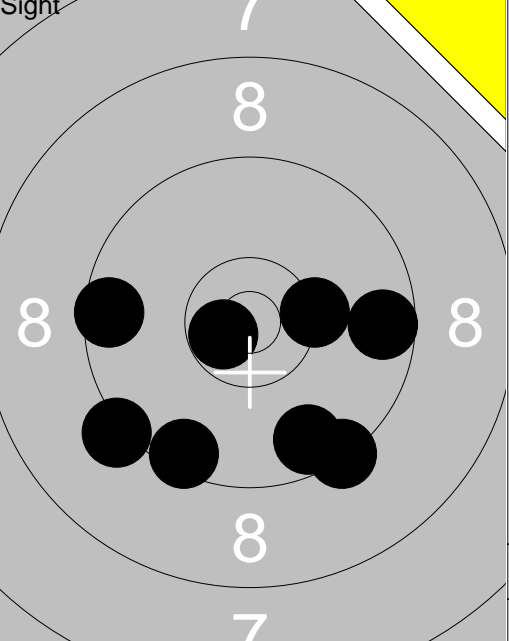
<p>Sight</p> 	<p>1: 8.6 ↙ 2: 7.4 ↓ 3: 9.6 ↓ 4: 8.9 ↙ 5: 7.4 ← 6: 9.5 ↙ 7: 10.0 ↗ 8: 9.3 ↗ 9: 9.8 ↗ 10: 9.0 ↙</p> <p>Series 85.0 Total 0.0</p>	<p>Sight</p> 	<p>11: 9.5 ↘ 12: 9.5 ← 13: 9.2 ↘ 14: 9.6 → 15: *10.7 ↘ 16: 9.3 ↓ 17: 9.6 ↓ 18: *10.3 →</p> <p>Series 74.0 Total 0.0</p>
---	---	---	---

<p>20 Shots</p> 	<p>1: *10.6 ↘ 2: 8.0 ↘ 3: 8.5 ↓ 4: 7.4 ↙ 5: *10.6 ↓</p> <p>Series 43.0 Total 43.0</p>	<p>20 Shots</p> 	<p>6: 6.7 ← 7: 9.4 ↗ 8: 10.1 → 9: 8.9 ↗ 10: *10.7 ↘</p> <p>Series 43.0 Total 86.0</p>
---	---	---	---

<p>20 Shots</p> 	<p>11: 9.3 ↙ 12: 6.8 ↙ 13: 8.9 ↙ 14: 8.0 ↗ 15: 9.2 ↙</p> <p>Series 40.0 Total 126.0</p>	<p>20 Shots</p> 	<p>16: 9.9 ↘ 17: 1.9 ↙ 18: 6.7 ↓ 19: 9.8 → 20: 8.5 ←</p> <p>Series 33.0 Total 159.0</p>
--	---	--	---

Relay 3	Lane 24	Daniel Wallberg	
-------------------	-------------------	------------------------	--

50m	Hogdal	Sen-S	Jä
-----	--------	-------	----

2013-07-09	Tavelträffen Korthäll 2013	Ramselefors SKF
------------	----------------------------	-----------------

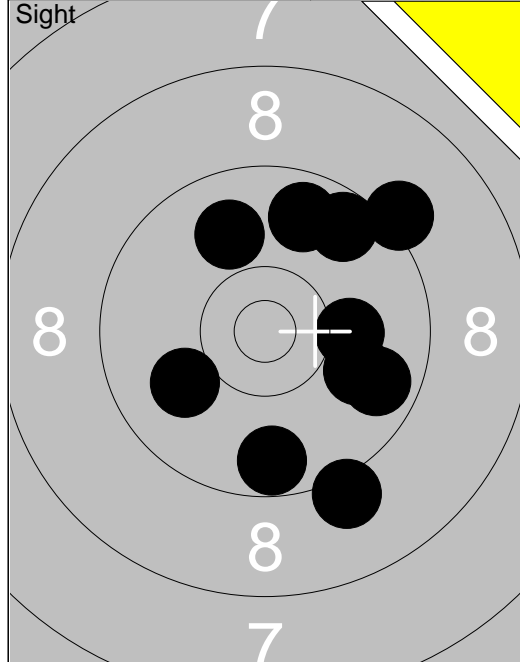

Series	92.0
Total	0.0

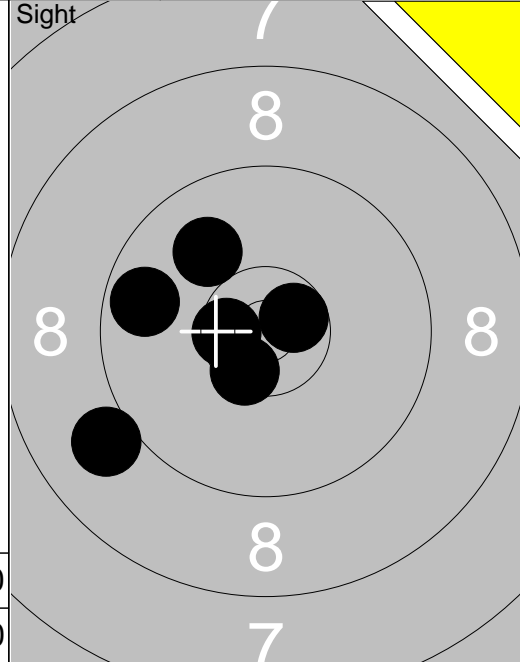

Series	58.0
Total	0.0

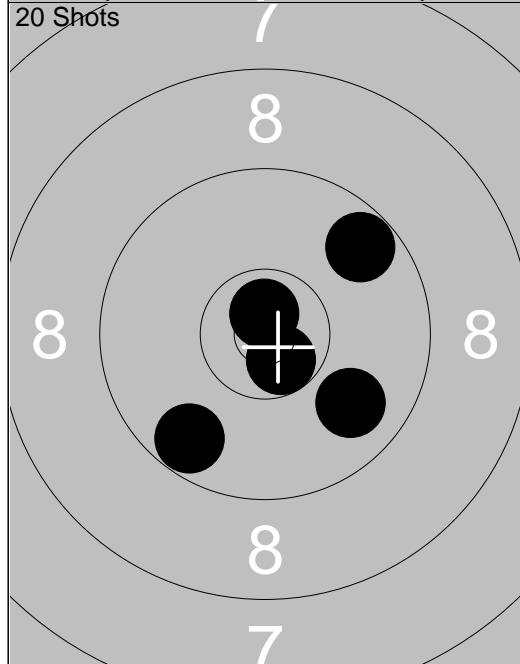

Series	47.0
Total	47.0

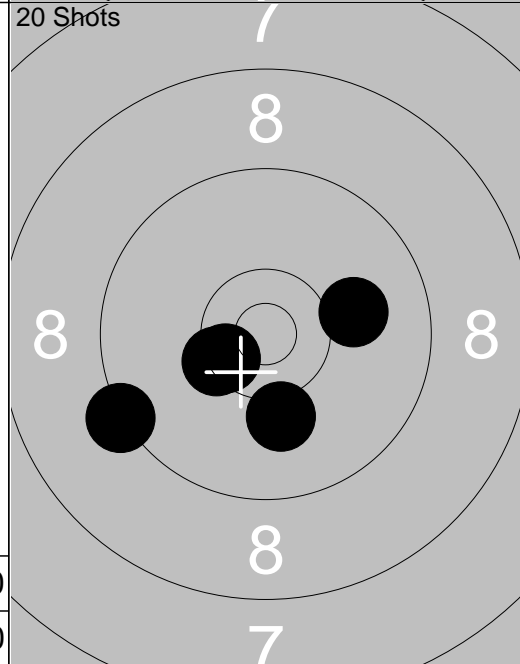

Series	49.0
Total	96.0

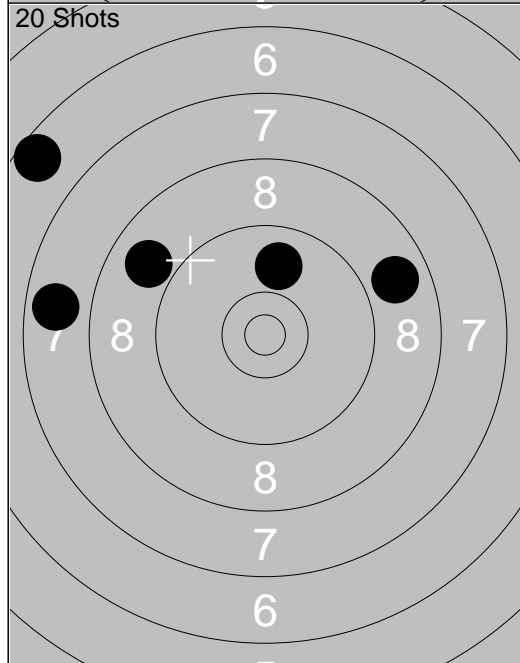

Series	38.0
Total	134.0

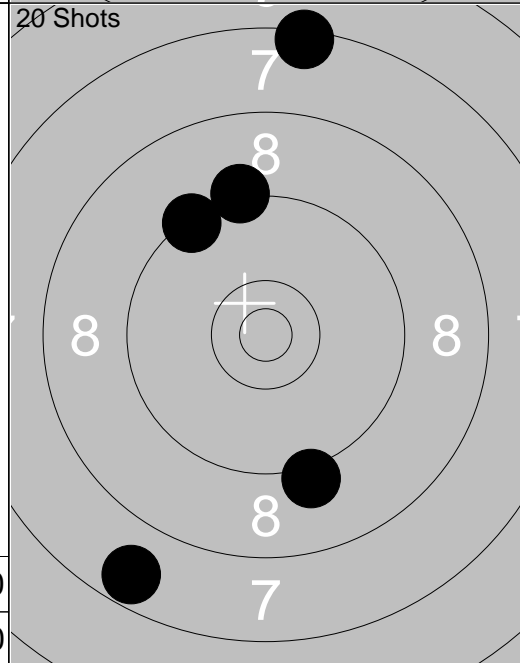

Series	41.0
Total	175.0

Relay 4	Lane 1	
50m		
2013-07-09	Tavelträffen Korthäll 2013	Ramselefors SKF

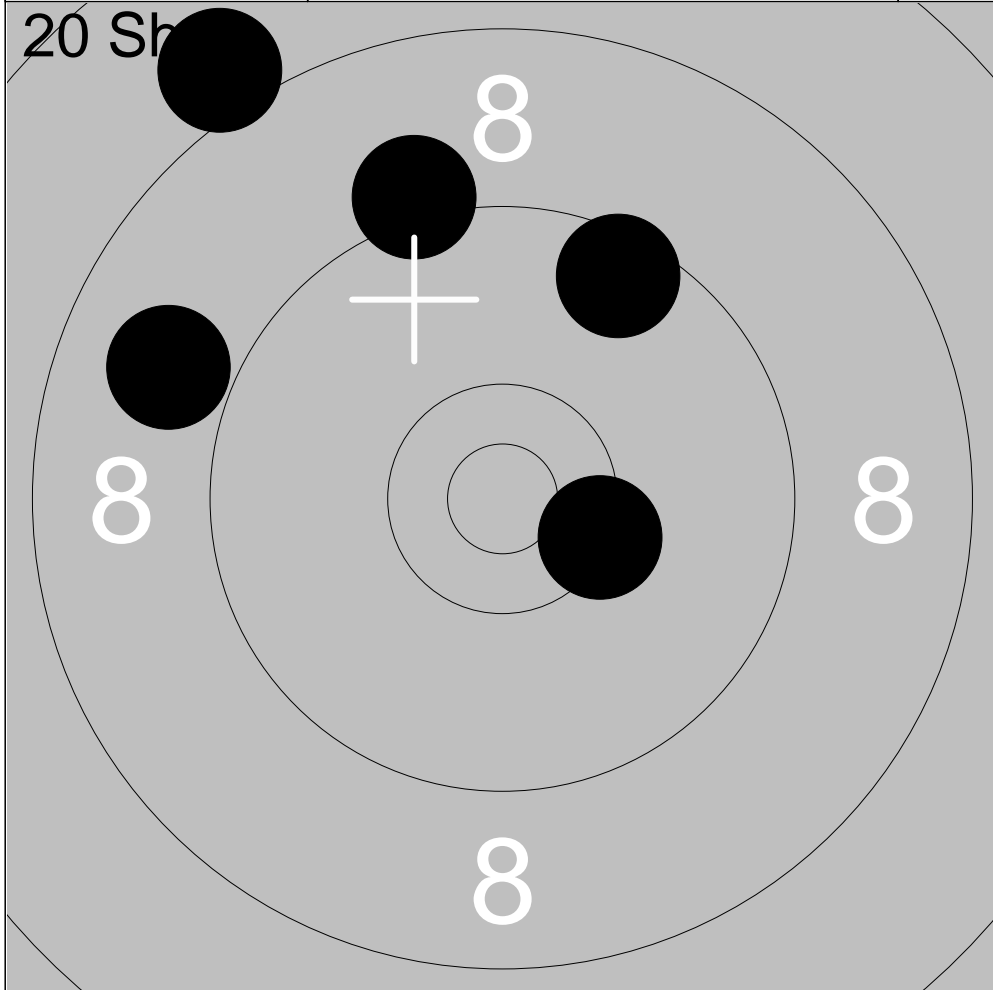

1:	8.9	↖
2:	9.5	↗
3:	*10.4	↘
4:	9.2	↗
5:	8.1	↗

Series	44.0
Total	44.0



6:	9.6	↗
7:	9.8	↖
8:	8.9	↖

Series	26.0
Total	70.0

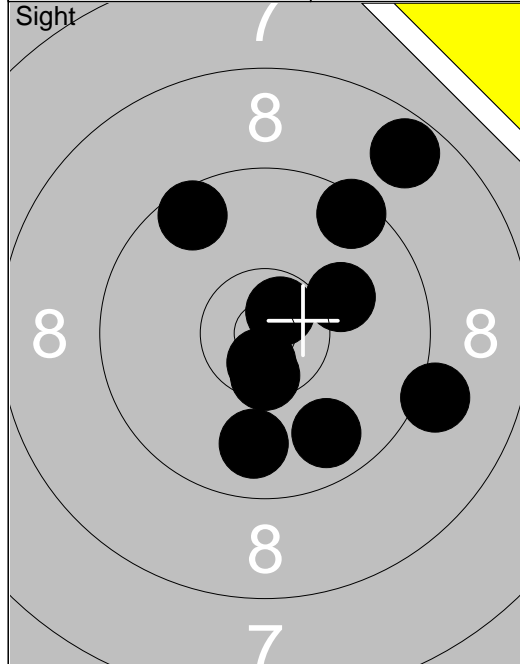

1: 8.7 ↗
2: 10.1 →
3: *10.7 ↓
4: 9.5 ↗
5: *10.7 ↗
6: 9.8 ↓
7: 9.1 →
8: *10.5 ↓
9: 9.8 ↓
10: 9.6 ↖
Series 93.0
Total 0.0

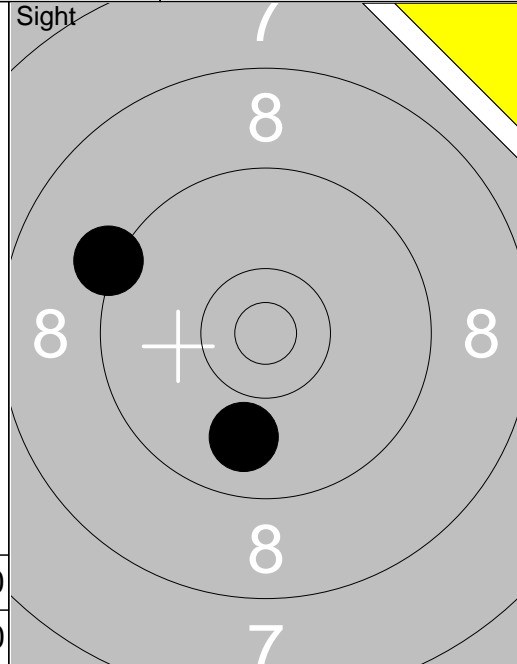

11: 9.2 ←
12: 9.9 ↓
Series 18.0
Total 0.0

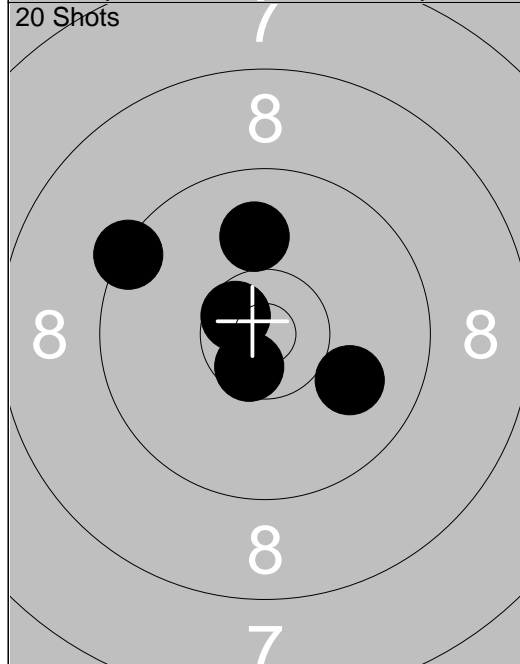

1: 9.4 ←
2: *10.6 ↖
3: *10.6 ↓
4: 10.0 →
5: 10.0 ↑
Series 49.0
Total 49.0

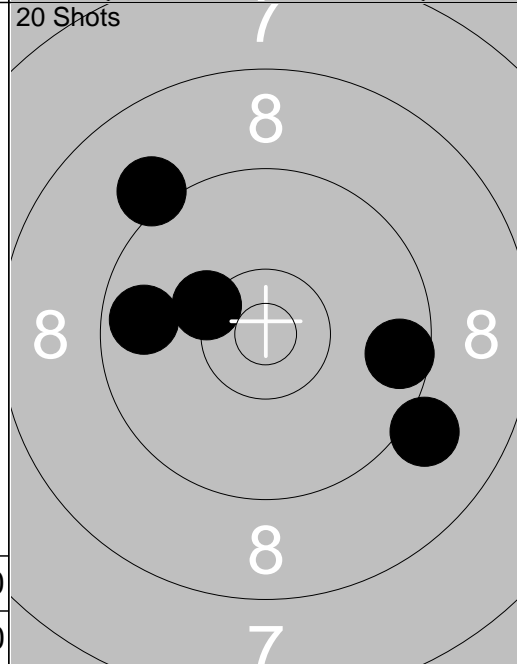

6: 9.1 →
7: 9.6 →
8: 9.7 ←
9: 9.1 ↗
10: *10.3 ↖
Series 46.0
Total 95.0

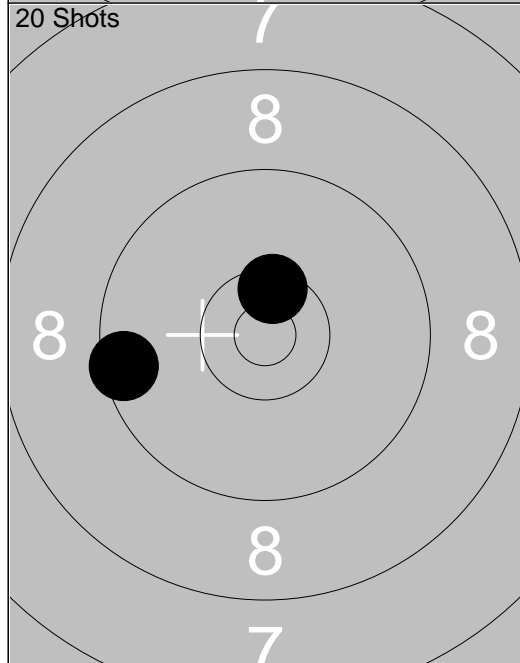

11: 9.5 ←
12: *10.5 ↑
Series 19.0
Total 114.0

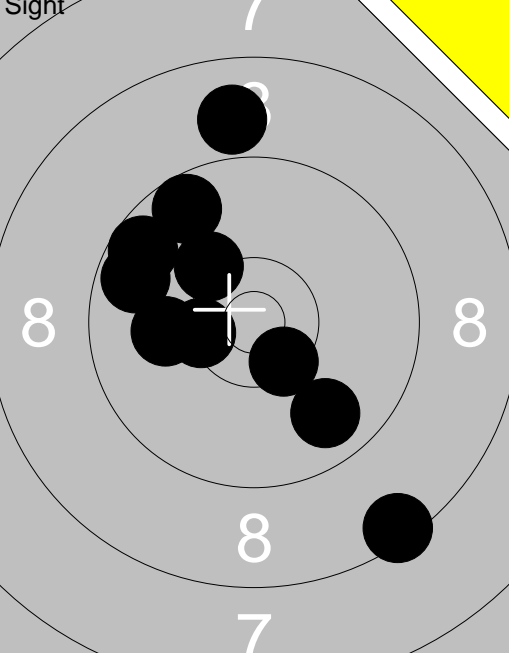
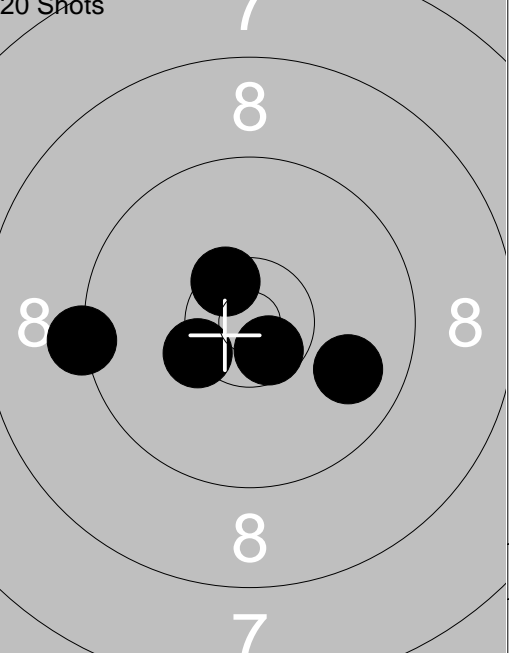
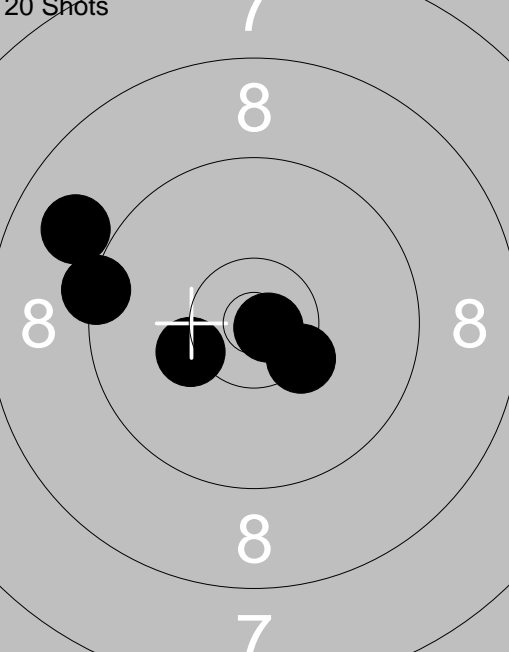
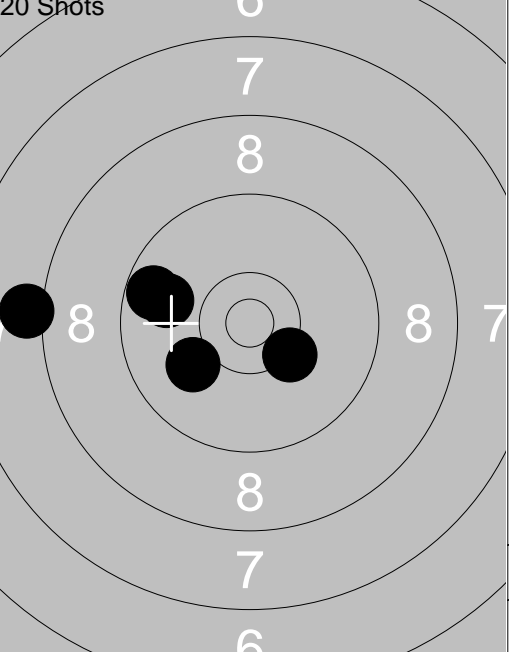
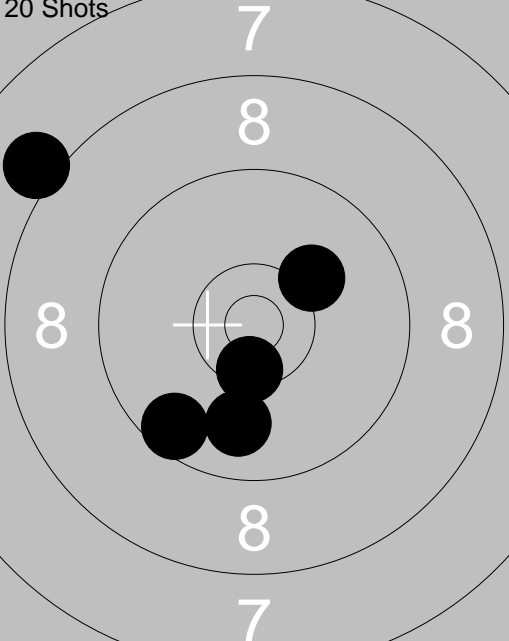
<p>Sight</p> 	<p>20 Shots</p> 	<p>1: 8.4 ↘ 2: 10.1 ← 3: 9.8 ↘ 4: 9.7 ↖ 5: 8.9 ↑ 6: *10.4 ← 7: *10.5 ↘ 8: 9.6 ↗ 9: 10.2 ↗ 10: 9.6 ↖</p> <p>Series 92.0 Total 0.0</p>	<p>1: 9.3 ← 2: *10.3 ↘ 3: 9.9 ↘ 4: *10.5 ↗ 5: *10.6 ↘</p> <p>Series 48.0 Total 48.0</p>
<p>20 Shots</p> 	<p>20 Shots</p> 	<p>6: 8.9 ↖ 7: *10.4 ↘ 8: 9.3 ← 9: *10.8 → 10: 10.3 ←</p> <p>Series 47.0 Total 95.0</p>	<p>11: 8.1 ← 12: 9.8 ← 13: *10.3 ↘ 14: 9.7 ← 15: 10.1 ↘</p> <p>Series 46.0 Total 141.0</p>
<p>20 Shots</p> 	<p>16: 9.6 ↘ 17: 10.2 ↗ 18: 9.9 ↘ 19: *10.5 ↘ 20: 8.1 ↖</p> <p>Series 46.0 Total 187.0</p>		

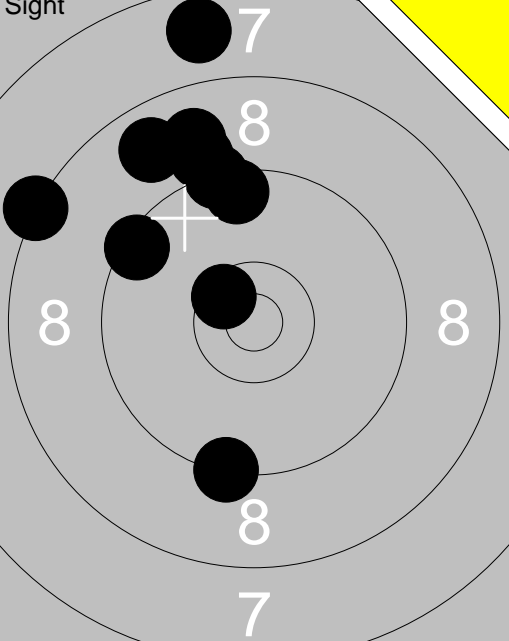
<p>Sight</p> 	<p>1: 8.9 ↗ 2: 8.8 ↗ 3: 8.3 ↖ 4: 9.1 ↗ 5: 9.5 ↗ 6: 9.5 ↖ 7: *10.5 ↖ 8: 7.7 ↗ 9: 9.3 ↘ 10: 9.3 ↗</p> <p>Series 86.0 Total 0.0</p>	<p>Sight</p> 	<p>11: 9.7 ↘ 12: 10.1 ↖</p> <p>Series 19.0 Total 0.0</p>
---	--	---	--

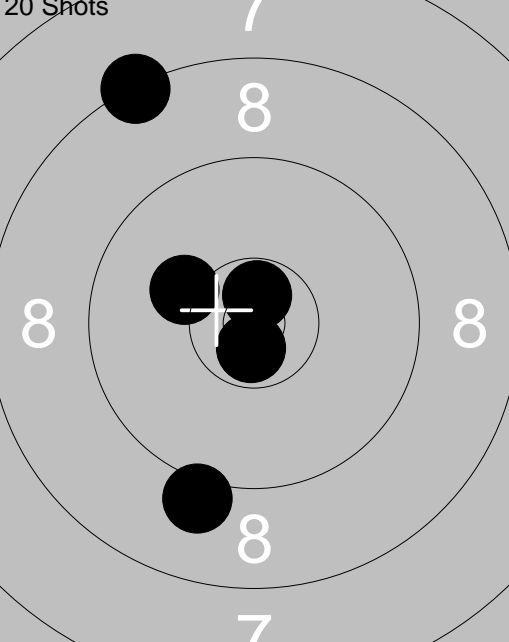
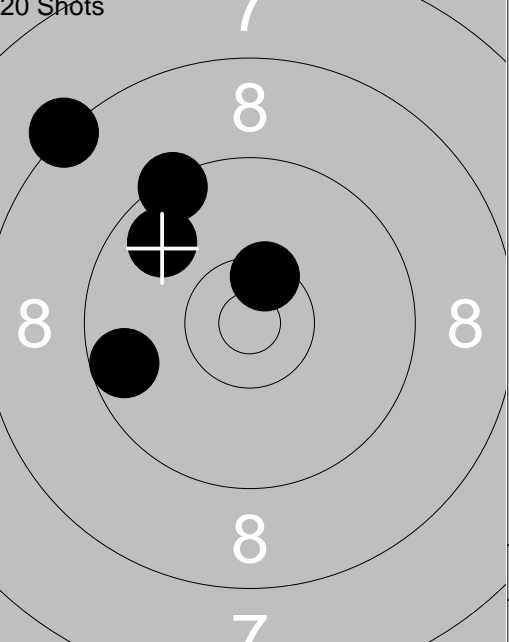
<p>20 Shots</p> 	<p>1: 9.1 ↘ 2: *10.7 ↗ 3: 10.2 ↖ 4: 8.3 ↗ 5: *10.7 ↘</p> <p>Series 47.0 Total 47.0</p>	<p>20 Shots</p> 	<p>6: 8.3 ↖ 7: 9.4 ↗ 8: 9.8 ↖ 9: *10.5 ↗ 10: 9.6 ↖</p> <p>Series 45.0 Total 92.0</p>
---	--	---	--

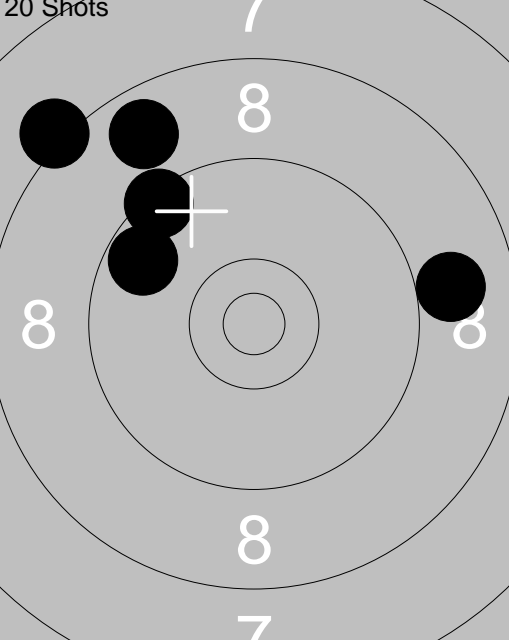
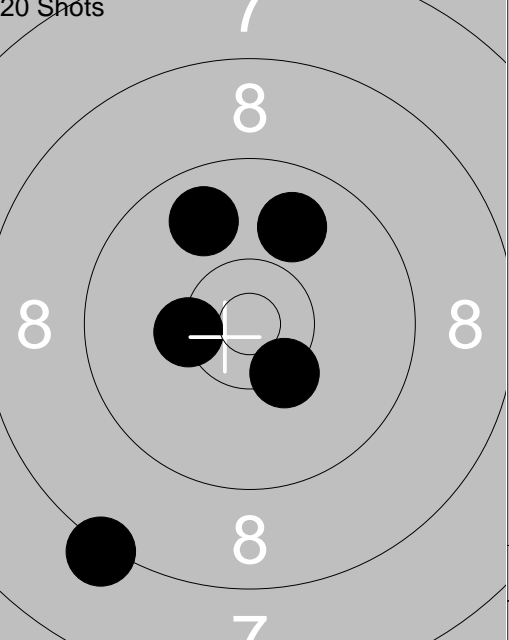
<p>20 Shots</p> 	<p>11: 9.4 ↖ 12: 9.7 ↖ 13: 8.2 ↗ 14: 8.8 ↗ 15: 9.0 →</p> <p>Series 43.0 Total 135.0</p>	<p>20 Shots</p> 	<p>16: *10.4 ↘ 17: 9.8 ↗ 18: 9.9 ↗ 19: 8.2 ↘ 20: *10.3 ↖</p> <p>Series 46.0 Total 181.0</p>
--	---	--	---

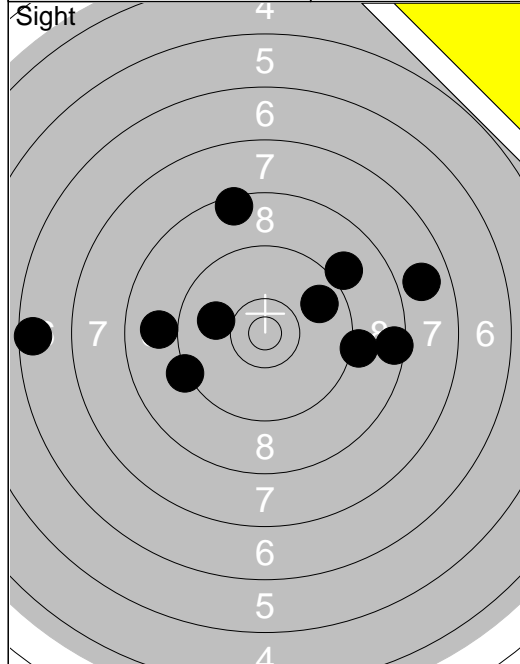

1:	9.0	←
2:	10.0	←
3:	6.6	←
4:	7.8	→
5:	8.5	→
6:	9.2	→
7:	9.3	←
8:	9.1	↗
9:	9.8	↗
10:	8.5	↑
Series		84.0
Total		0.0

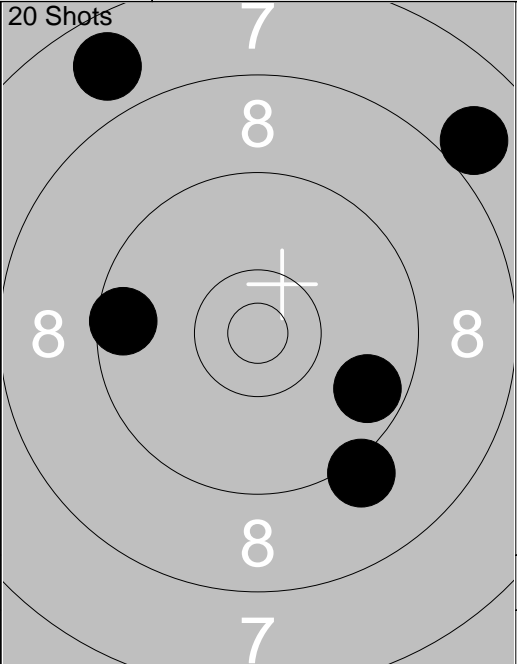

1:	9.6	←
2:	7.8	↖
3:	8.0	↗
4:	9.7	↘
5:	9.2	↘
Series		42.0
Total		42.0

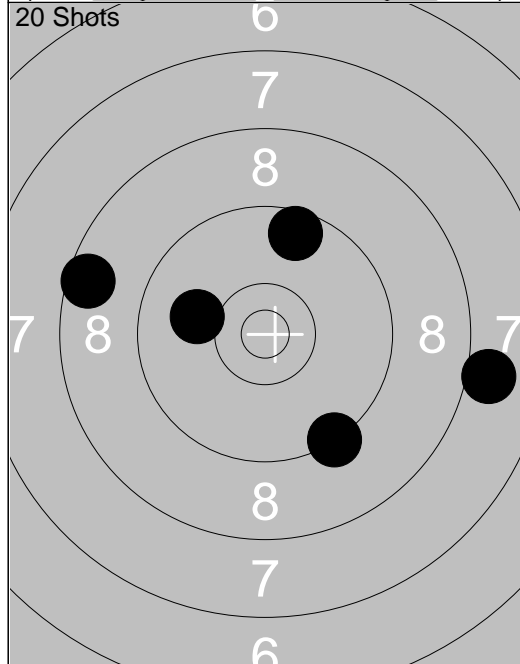

6:	8.6	←
7:	9.3	↘
8:	9.6	↑
9:	8.0	→
10:	10.0	←
Series		44.0
Total		86.0

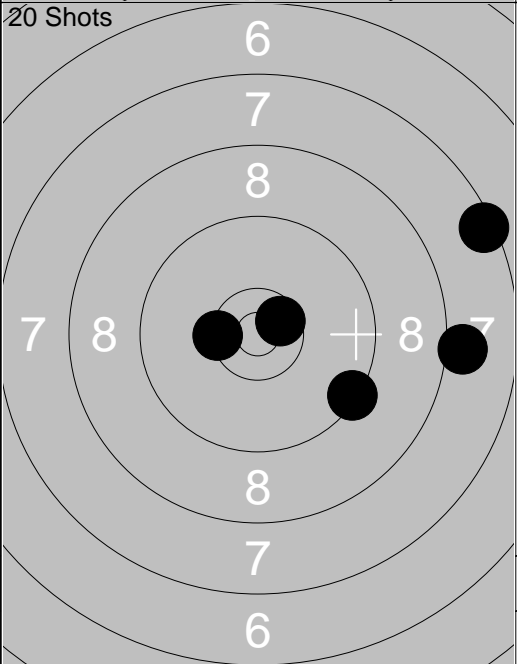

11:	7.4	↗
12:	8.1	→
13:	9.4	↘
14:	*10.4	←
15:	*10.6	↗
Series		44.0
Total		130.0

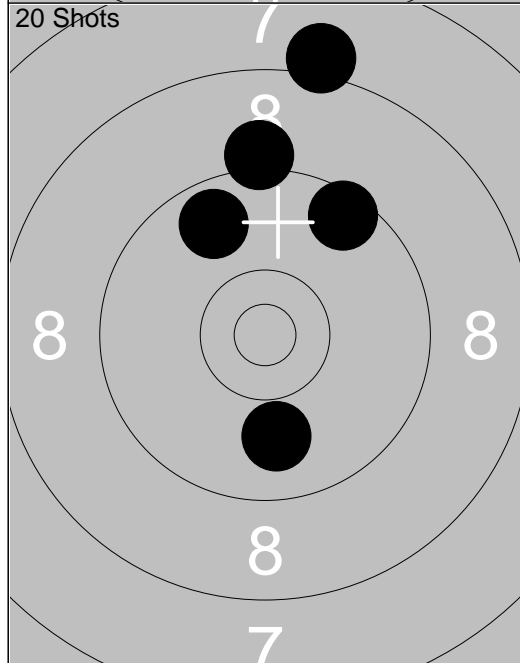

16:	9.5	↗
17:	8.1	↑
18:	9.7	↖
19:	9.2	↑
20:	9.9	↓
Series		44.0
Total		174.0

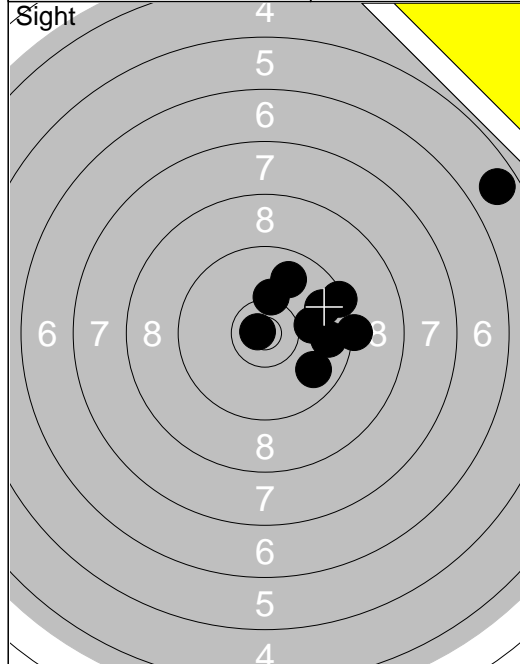

1:	5.7	➔
2:	*10.8	↙
3:	9.4	➔
4:	9.8	➔
5:	9.3	➔
6:	10.0	➔
7:	10.3	⬆
8:	9.8	↘
9:	9.7	➔
10:	9.8	⬆

Series	89.0
Total	0.0

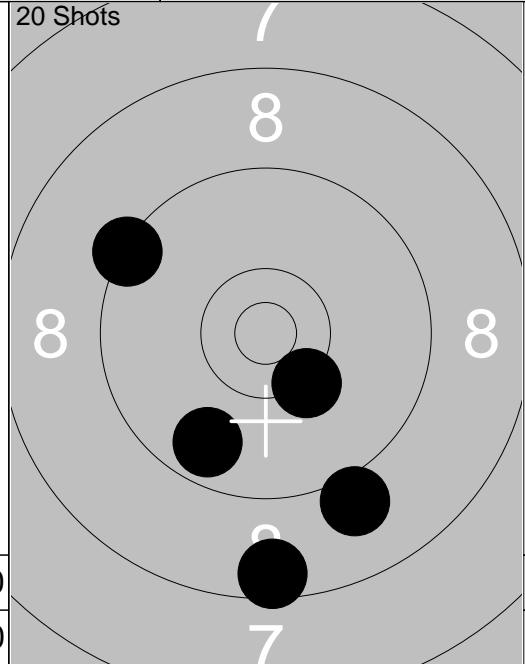

1:	8.6	⬇
2:	*10.3	↘
3:	9.1	⬇
4:	9.7	↘
5:	9.3	↙

Series	45.0
Total	45.0

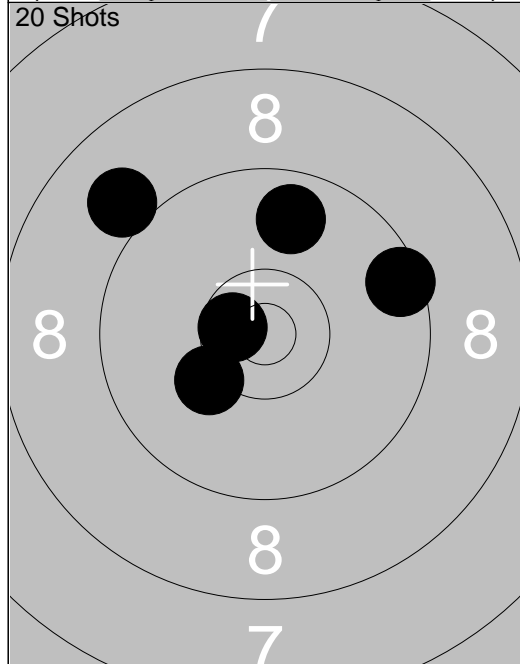

6:	9.5	➔
7:	*10.6	↙
8:	9.0	↙
9:	9.8	⬆
10:	10.2	↘

Series	47.0
Total	92.0

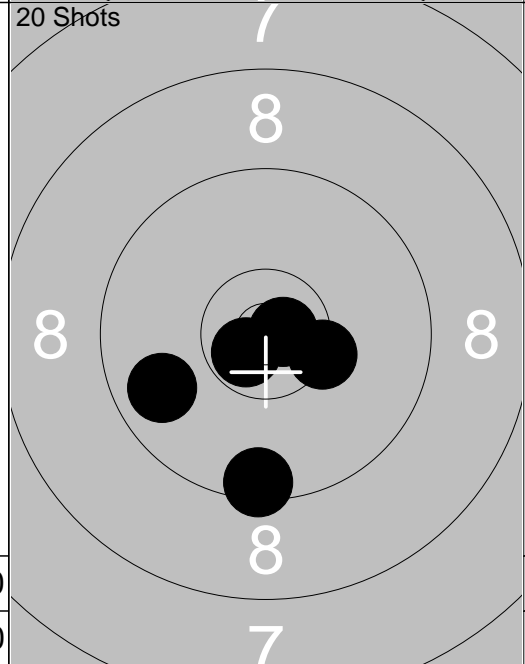

11:	9.8	↙
12:	*10.8	➔
13:	*10.7	↘
14:	9.5	⬇
15:	*10.3	➔

Series	48.0
Total	140.0

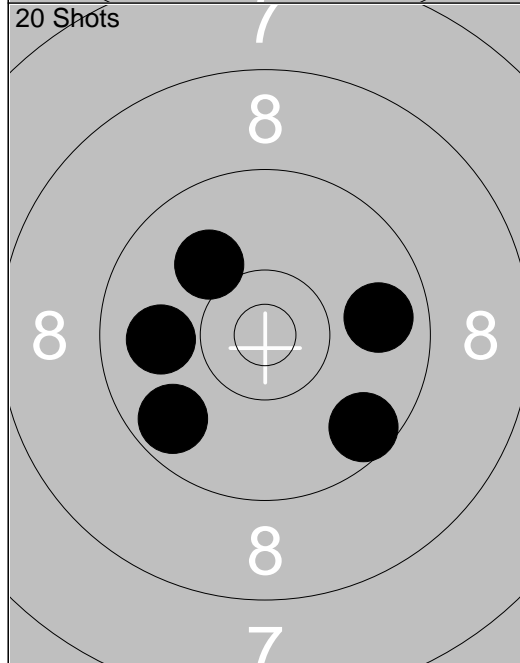

16:	9.6	↘
17:	9.8	➔
18:	9.7	↘
19:	9.9	↙
20:	10.1	↙

Series	46.0
Total	186.0

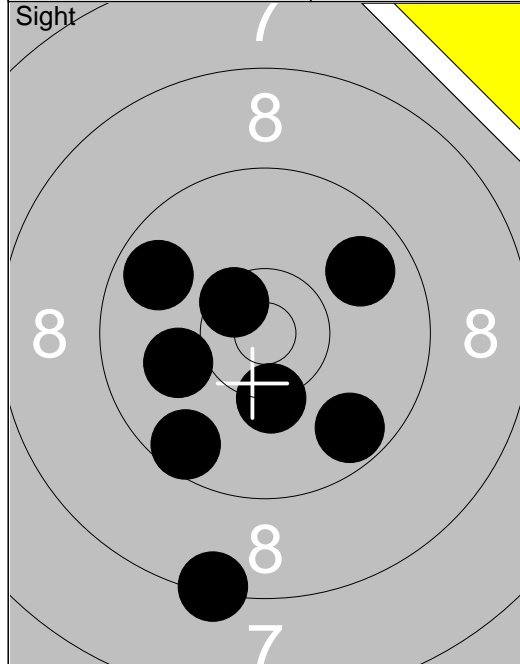

1:	9.6	↙
2:	8.4	↓
3:	9.8	↗
4:	*10.3	↓
5:	9.7	↖
6:	9.7	↓
7:	10.0	←
8:	*10.5	↖
Series		74.0
Total		0.0

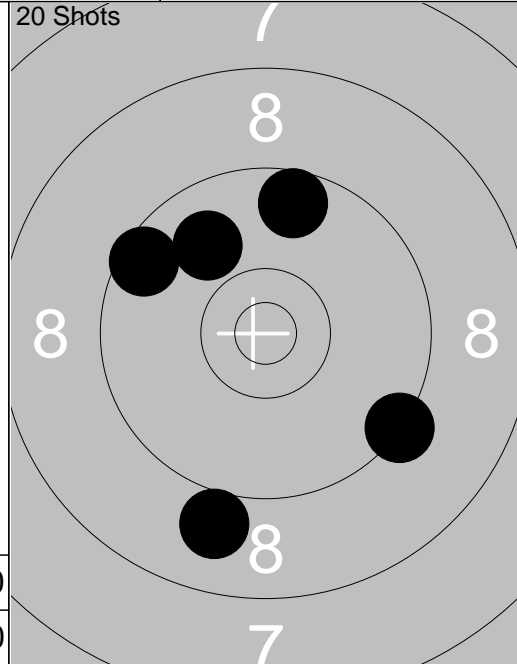

1:	9.0	↓
2:	9.5	↖
3:	9.9	↗
4:	9.3	↘
5:	9.6	↑
Series		45.0
Total		45.0

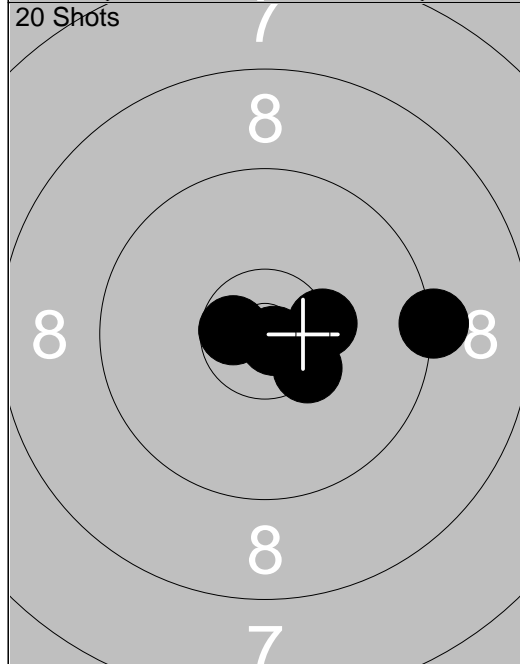

6:	*10.4	→
7:	9.3	→
8:	*10.8	↘
9:	*10.4	↘
10:	*10.6	←
Series		49.0
Total		94.0

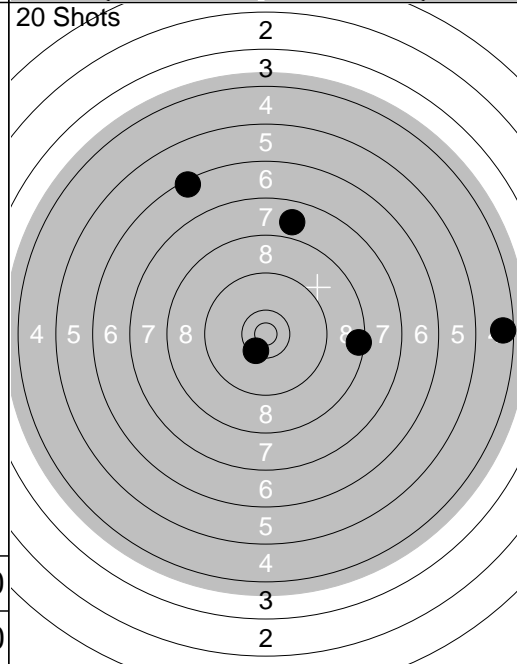

11:	6.4	↖
12:	7.9	↑
13:	*10.4	↘
14:	4.6	→
15:	8.4	→
Series		35.0
Total		129.0

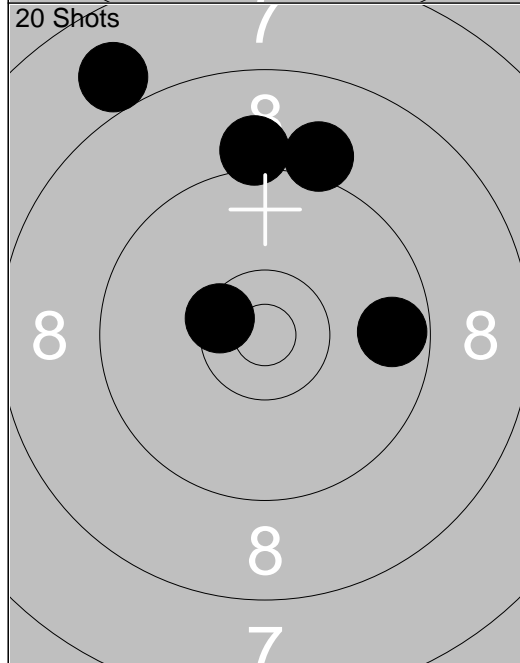

16:	9.1	↑
17:	9.7	→
18:	*10.5	↖
19:	8.0	↖
20:	9.1	↑
Series		45.0
Total		174.0

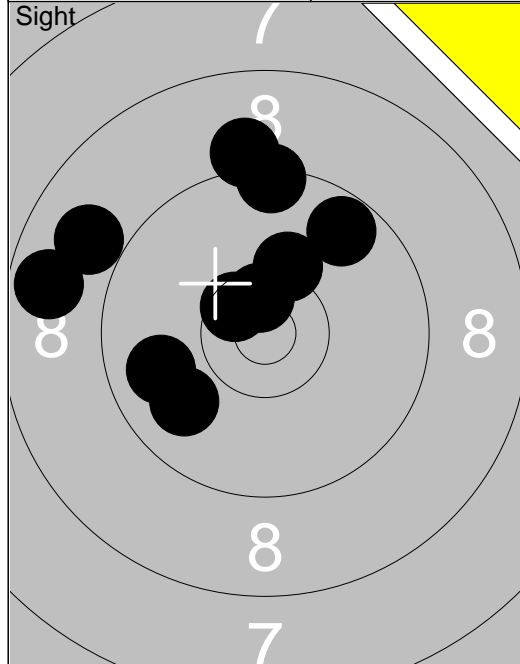

1: 9.8 ←
2: 8.9 ↖
3: 8.7 ←
4: *10.5 ↘
5: 10.2 ↗
6: *10.6 ↗
7: 9.1 ↑
8: 9.7 ↗
9: 9.4 ↑
10: 9.9 ↙
Series 91.0
Total 0.0

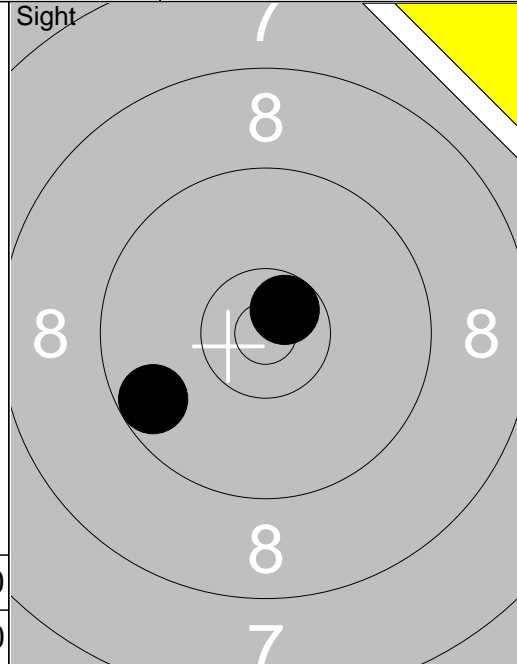

11: 9.6 ↙
12: *10.6 ↗
Series 19.0
Total 0.0

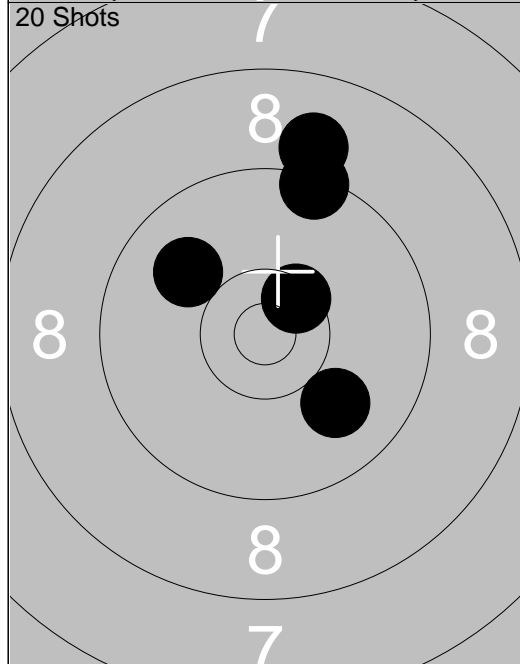

1: 10.0 ↘
2: 9.0 ↑
3: 9.4 ↑
4: *10.5 ↗
5: 10.0 ↖
Series 48.0
Total 48.0

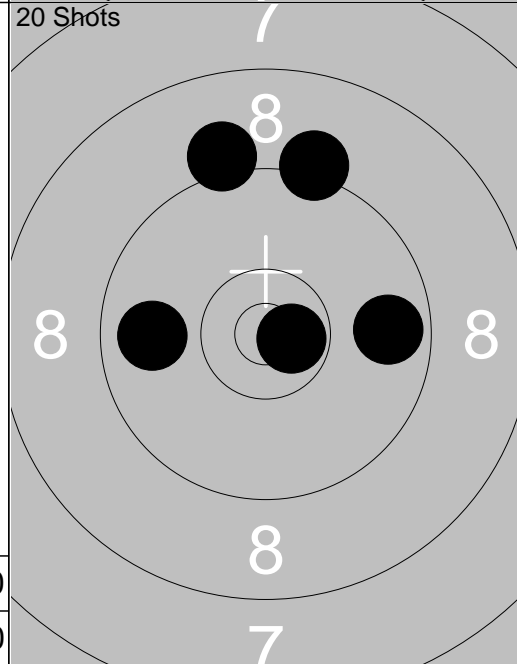

6: 9.2 ↑
7: 9.7 →
8: 9.1 ↑
9: *10.7 →
10: 9.8 ←
Series 46.0
Total 94.0

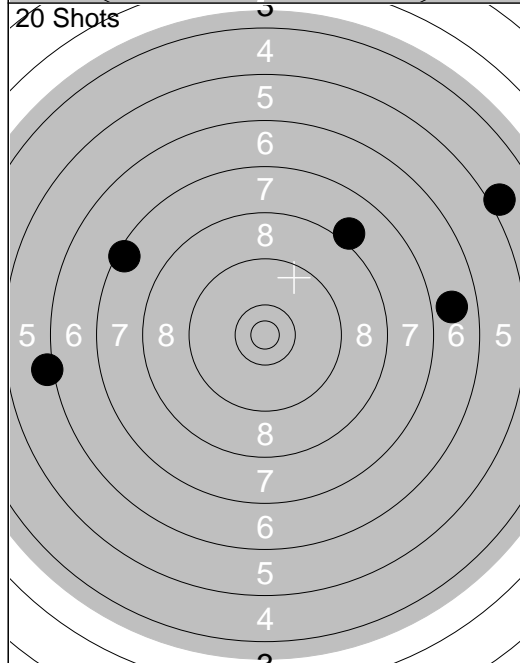

11: 6.2 ←
12: 6.9 →
13: 5.1 ↗
14: 8.1 ↗
15: 7.5 ↖
Series 32.0
Total 126.0

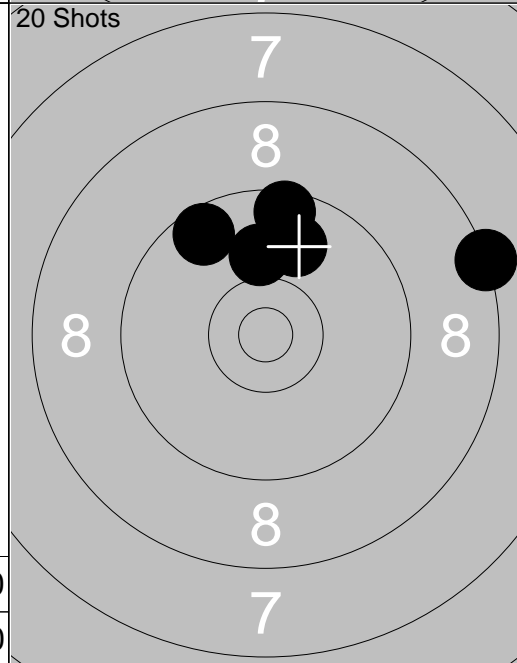

16: 9.5 ↑
17: 9.9 ↗
18: 10.0 ↑
19: 8.3 →
20: 9.6 ↖
Series 45.0
Total 171.0

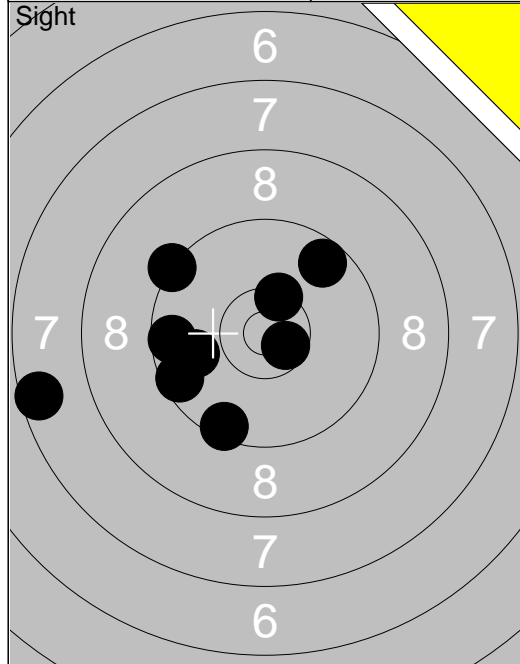

- 1: *10.4 ↗
- 2: *10.6 ↘
- 3: 7.6 ←
- 4: 9.6 ←
- 5: 9.3 ↖
- 6: 9.9 ←
- 7: 9.6 ↗
- 8: 9.6 ←
- 9: 9.5 ↓

Series 81.0
Total 0.0

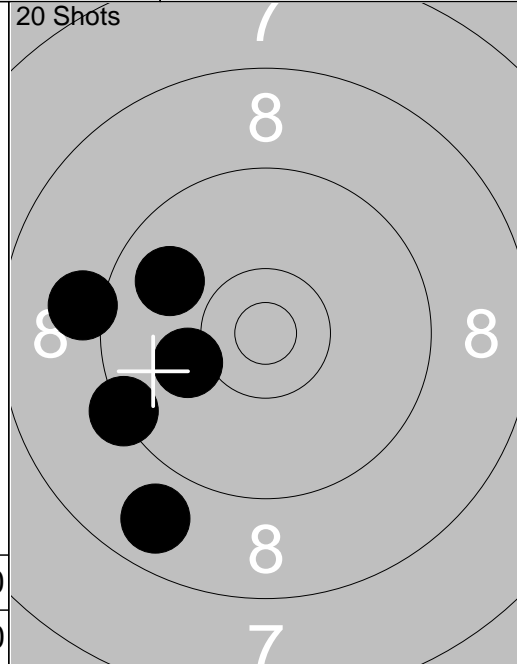

- 1: 8.8 ↓
- 2: 10.1 ↖
- 3: 9.1 ←
- 4: 9.3 ↖
- 5: 9.9 ↖

Series 45.0
Total 45.0

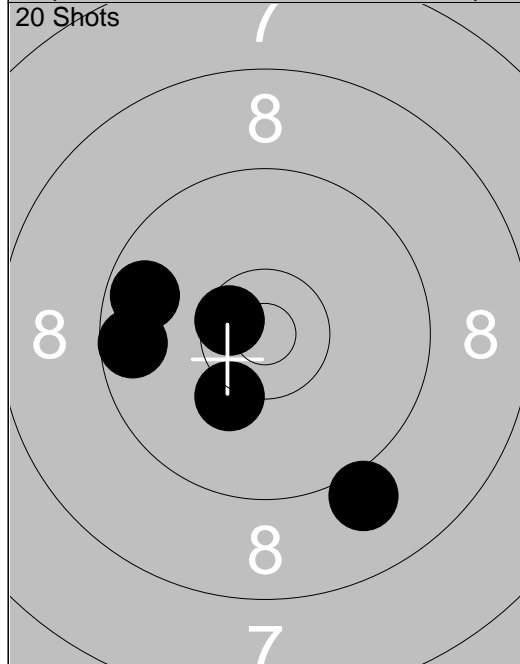

- 6: 9.1 ↓
- 7: 10.2 ↓
- 8: 9.6 ←
- 9: 9.7 ←
- 10: *10.6 ↖

Series 47.0
Total 92.0

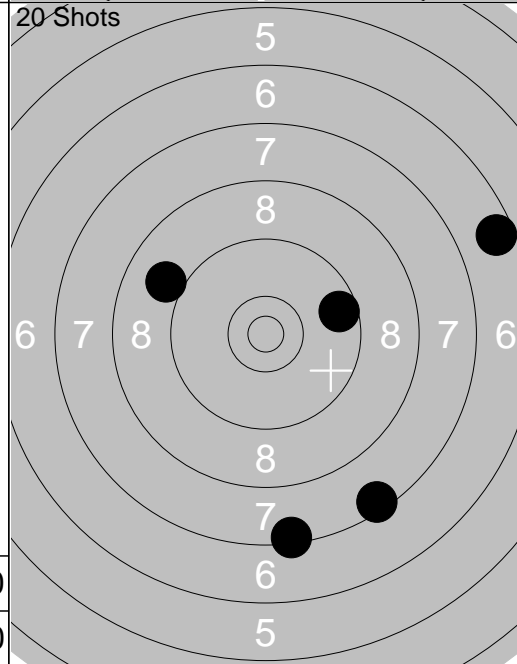

- 11: 9.6 →
- 12: 6.6 →
- 13: 9.0 ↖
- 14: 7.5 ↓
- 15: 7.4 ↓

Series 38.0
Total 130.0

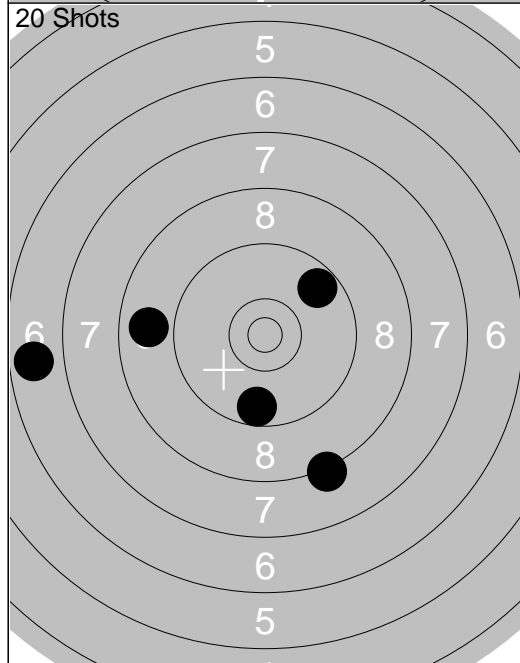

- 16: 9.7 ↗
- 17: 8.2 ↓
- 18: 6.8 ←
- 19: 9.7 ↓
- 20: 8.8 ←

Series 40.0
Total 170.0

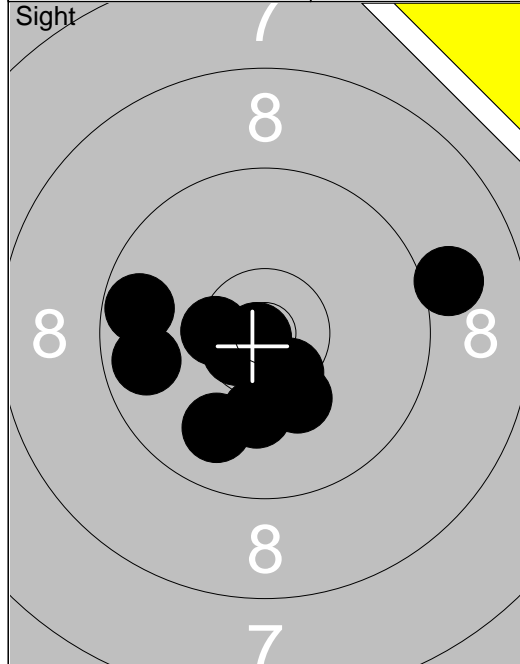

1: 9.9 ↘
2: *10.9 ↘
3: 9.7 ←
4: *10.5 ↘
5: *10.6 ↘
6: 9.0 →
7: 10.1 ↓
8: *10.5 ↘
9: 9.7 ←
10: 10.2 ↓
Series 96.0
Total 0.0

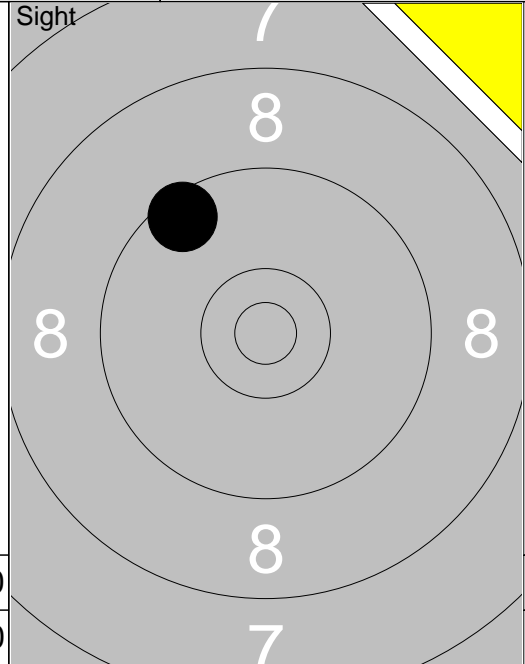

11: 9.5 ↖
Series 9.0
Total 0.0

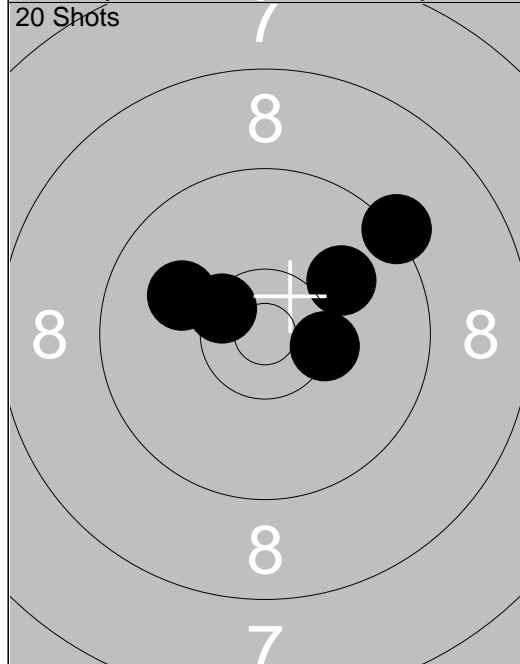

1: 10.0 ↖
2: 10.0 ↗
3: 9.3 ↗
4: *10.5 ↖
5: *10.3 →
Series 49.0
Total 49.0

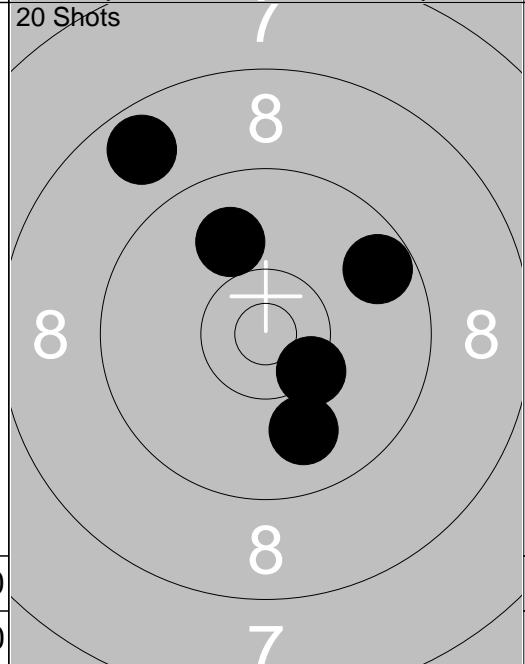

6: 9.9 ↓
7: 10.0 ↖
8: *10.4 ↘
9: 8.7 ↖
10: 9.7 ↗
Series 46.0
Total 95.0

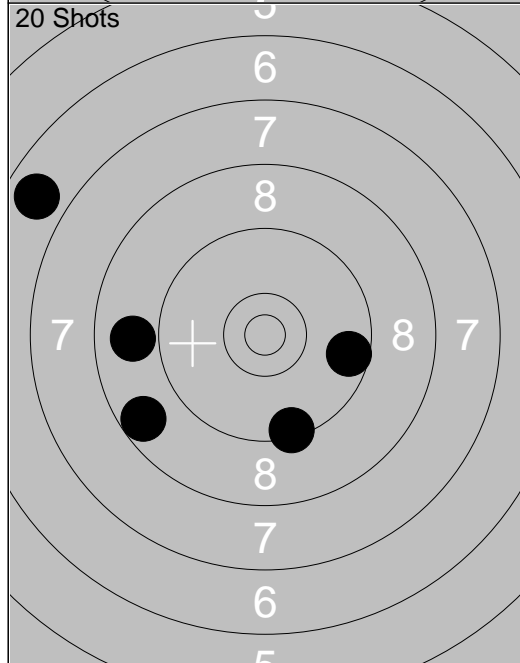

11: 8.9 ←
12: 6.8 ↖
13: 9.6 →
14: 8.7 ↖
15: 9.4 ↓
Series 40.0
Total 135.0

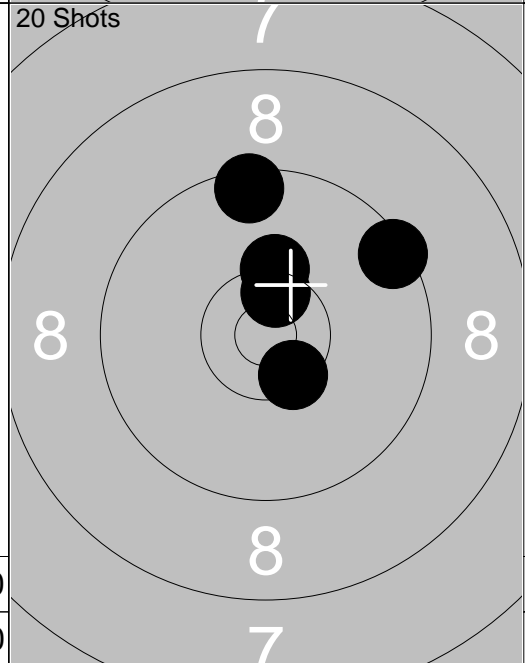

16: 9.4 ↗
17: *10.5 ↘
18: 10.3 ↑
19: 9.5 ↑
20: *10.5 ↗
Series 48.0
Total 183.0

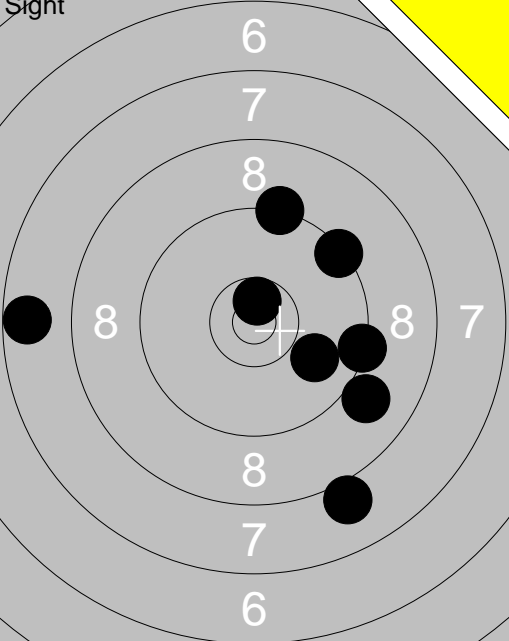
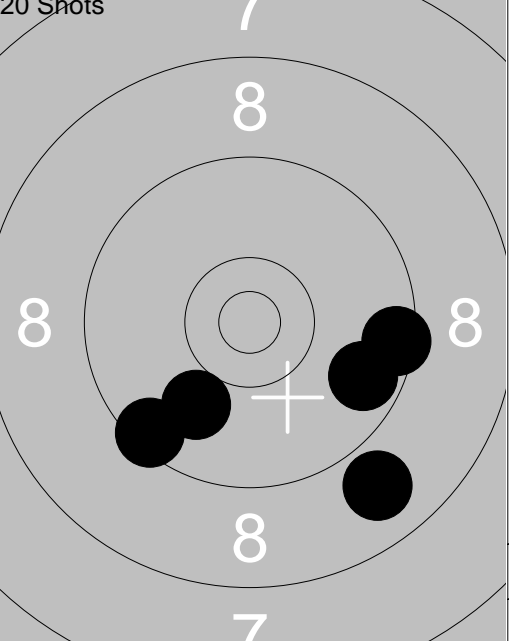
<p>Sight</p> 	<p>1: 8.0 ↘ 2: 9.3 ↑ 3: 7.7 ← 4: 9.4 ↗ 5: 9.3 → 6: 9.0 ↘ 7: 9.9 ↘ 8: *10.6↑</p>	<p>20 Shots</p> 	<p>1: 8.9 ↘ 2: 10.0 ↘ 3: 9.5 → 4: 9.5 ↘ 5: 9.7 ↘</p>
Series 70.0		Series 45.0	
Total 0.0		Total 45.0	

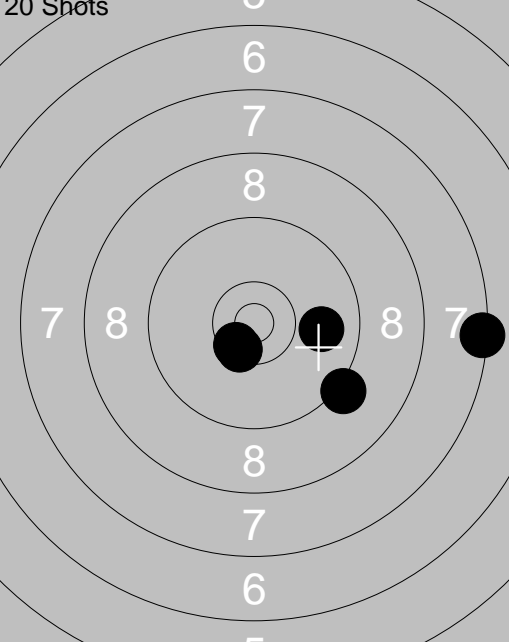
<p>20 Shots</p> 	<p>6: 9.9 → 7: *10.5↘ 8: 7.4 → 9: *10.5↘ 10: 9.2 ↘</p>	<p>20 Shots</p> 	<p>11: 7.4 ↘ 12: 7.7 ↑ 13: 8.0 → 14: 8.5 ↓ 15: 8.2 ↘</p>
Series 45.0		Series 38.0	
Total 90.0		Total 128.0	

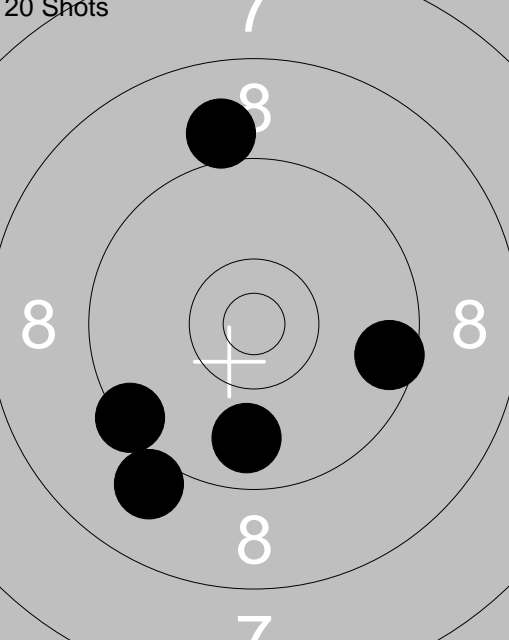
<p>20 Shots</p> 	<p>16: 9.0 ↘ 17: 9.6 → 18: 9.0 ↑ 19: 9.4 ↙ 20: 9.8 ↓</p>		
Series 45.0			
Total 173.0			

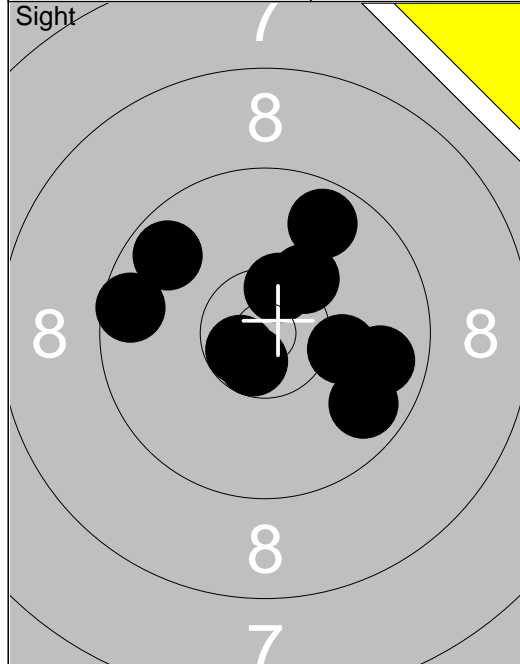

1: *10.7 ↘
2: *10.5 ↗
3: 9.7 ↙
4: 9.7 →
5: 9.7 ↗
6: 9.6 ←
7: 10.3 ↗
8: 9.8 →
9: 10.2 →
10: *10.6 ↘
Series 95.0
Total 0.0

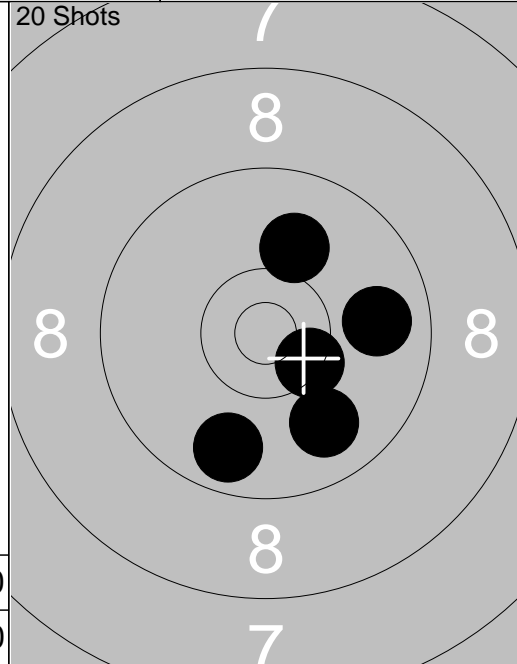

1: 9.8 →
2: *10.4 ↘
3: 9.9 ↘
4: 9.7 ↘
5: 10.0 ↗
Series 47.0
Total 47.0

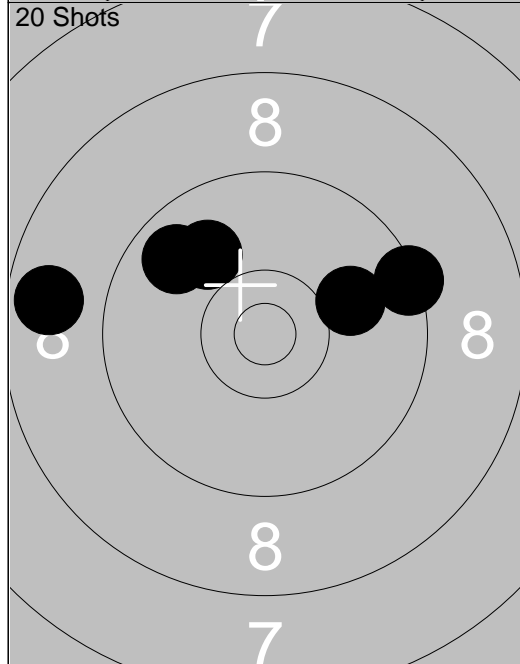

6: 9.4 →
7: 10.0 →
8: 10.0 ↗
9: 8.7 ←
10: 9.8 ↗
Series 46.0
Total 93.0

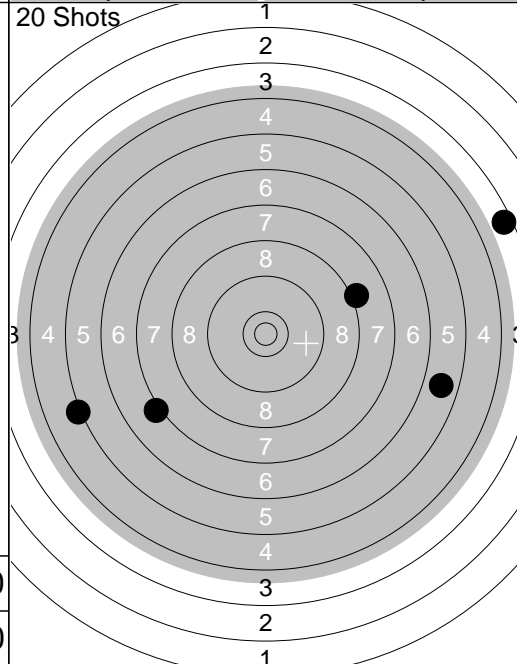

11: 5.2 ←
12: 8.2 →
13: 5.8 →
14: 3.5 →
15: 7.2 ↙
Series 28.0
Total 121.0

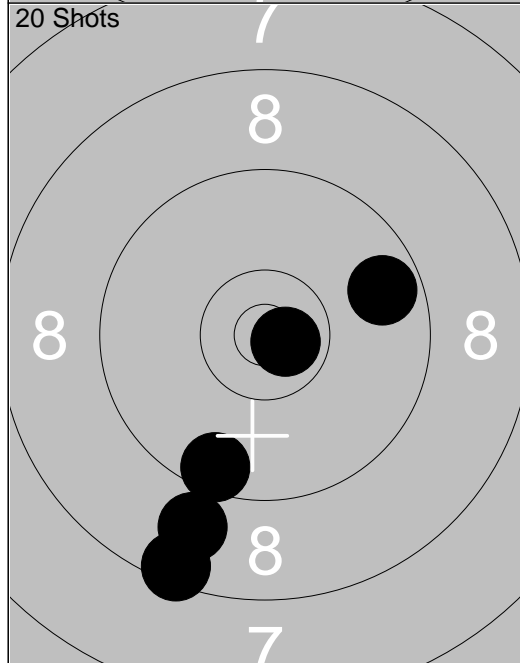

16: 8.5 ↘
17: 8.9 ↘
18: *10.7 →
19: 9.5 ↘
20: 9.7 →
Series 44.0
Total 165.0

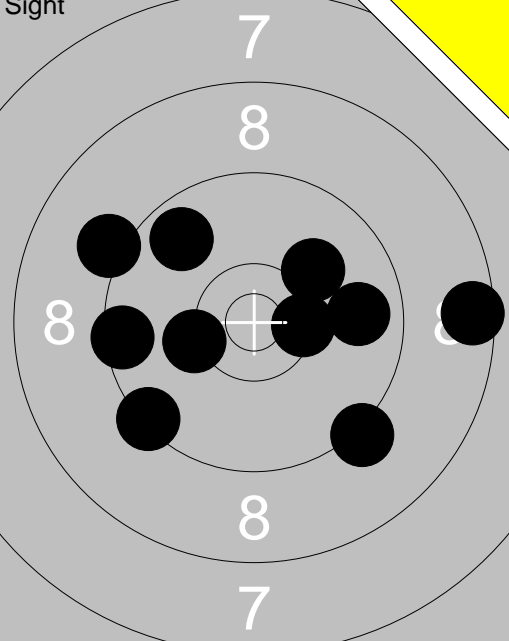
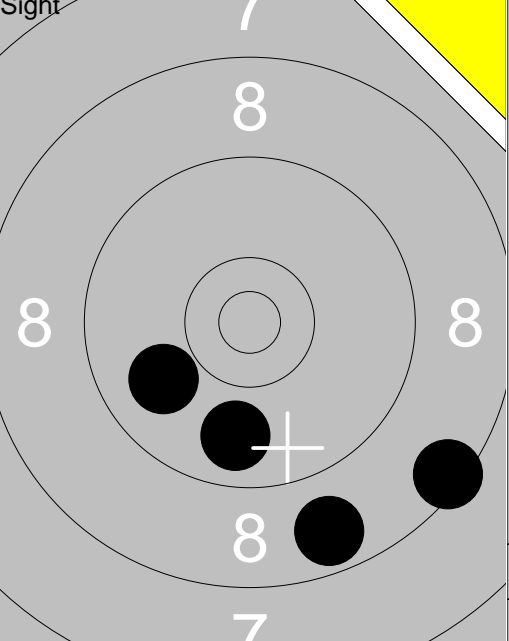
<p>Sight</p> 	<p>Sight</p> 	<p>1: 9.7 ↗ 2: 9.1 ↖ 3: 10.1 ↗ 4: 9.5 ← 5: 9.2 ↘ 6: 8.5 → 7: 10.3 ← 8: 9.8 → 9: 9.4 ↘ 10: *10.4 →</p> <p>Series 92.0 Total 0.0</p>	<p>11: 9.8 ↓ 12: 8.5 ↘ 13: 8.7 ↓ 14: 9.9 ↖</p> <p>Series 34.0 Total 0.0</p>
---	---	--	---

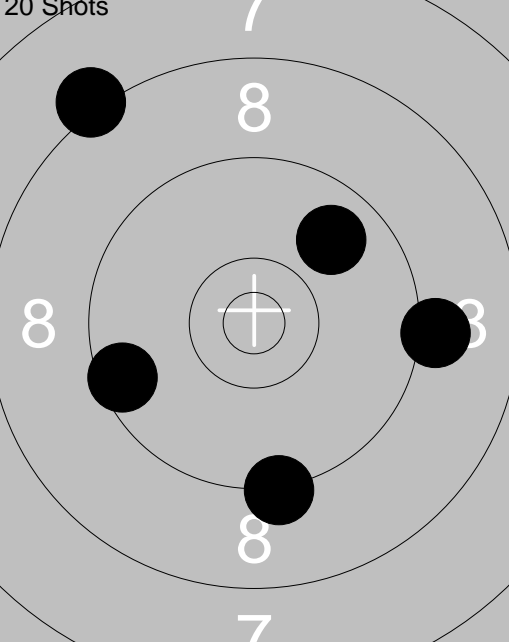
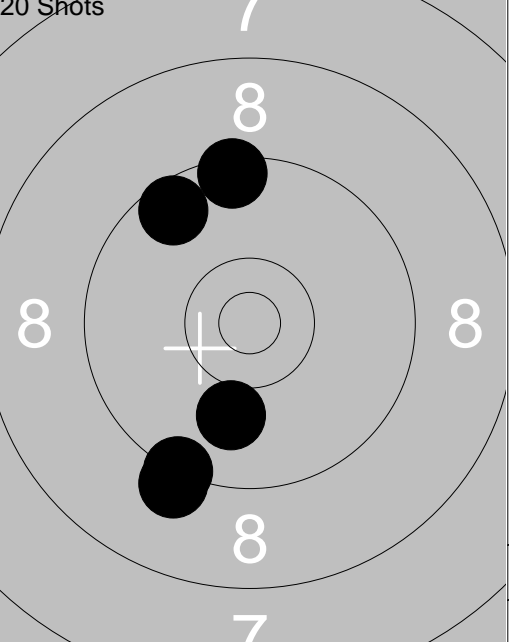
<p>20 Shots</p> 	<p>20 Shots</p> 	<p>1: 9.5 ← 2: 9.3 ↓ 3: 8.2 ↗ 4: 9.8 ↗ 5: 9.1 →</p> <p>Series 44.0 Total 44.0</p>	<p>6: 9.6 ↖ 7: 9.2 ↘ 8: 10.0 ↓ 9: 9.4 ↑ 10: 9.3 ↘</p> <p>Series 46.0 Total 90.0</p>
---	---	---	---

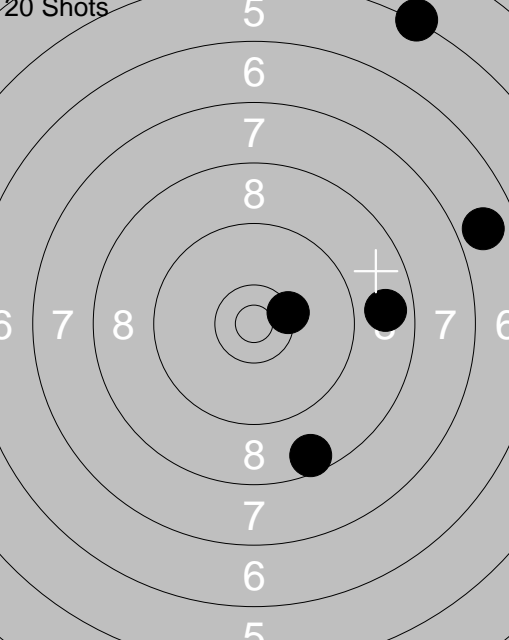
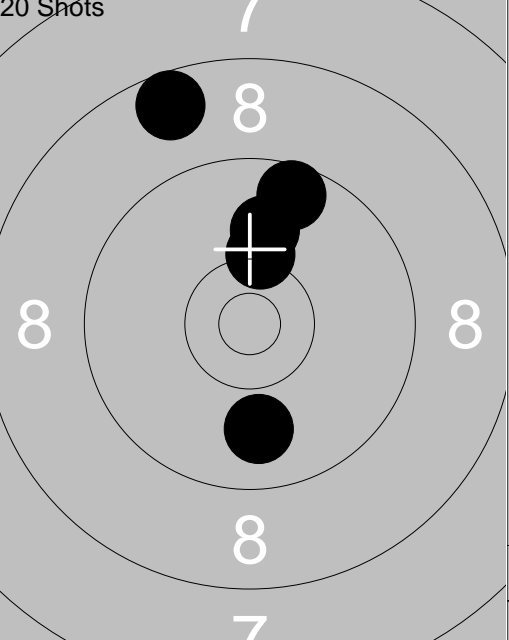
<p>20 Shots</p> 	<p>20 Shots</p> 	<p>11: 8.8 → 12: 6.9 → 13: 5.3 ↗ 14: 8.6 ↓ 15: *10.4 →</p> <p>Series 37.0 Total 127.0</p>	<p>16: 10.2 ↑ 17: 8.6 ↖ 18: 10.0 ↑ 19: 9.6 ↑ 20: 9.9 ↓</p> <p>Series 46.0 Total 173.0</p>
--	--	---	---

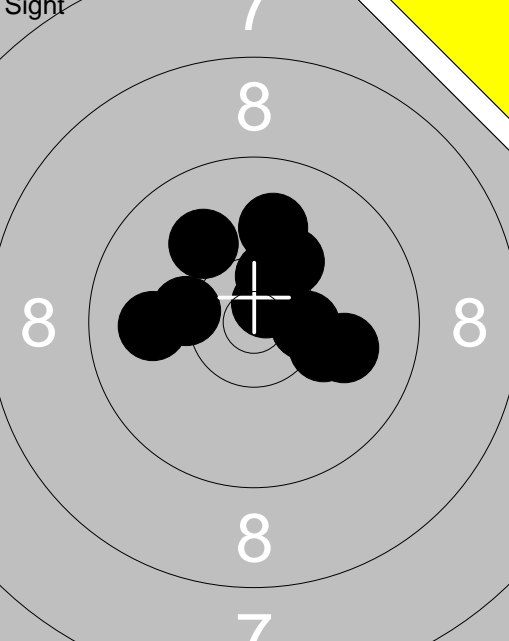
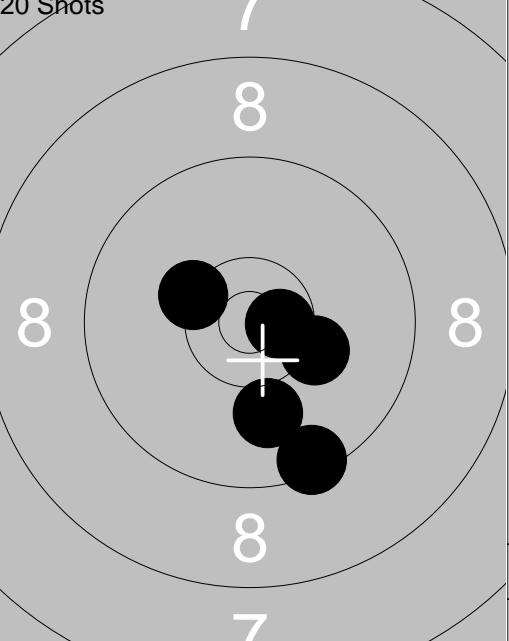
<p>Sight</p> 	<p>20 Shots</p> 	<p>1: 9.9 ←</p> <p>2: 10.0 ↑</p> <p>3: 10.2 →</p> <p>4: *10.4 →</p> <p>5: 10.0 ↖</p> <p>6: *10.5 ↑</p> <p>7: 10.0 →</p> <p>8: 10.3 ←</p> <p>9: *10.7 ↑</p> <p>10: 10.3 ↗</p> <hr/> <p>Series 99.0</p> <p>Total 0.0</p>	<p>1: *10.3 ↖</p> <p>2: 10.2 →</p> <p>3: 10.0 ↓</p> <p>4: *10.6 →</p> <p>5: 9.4 ↓</p> <hr/> <p>Series 49.0</p> <p>Total 49.0</p>
---	--	--	--

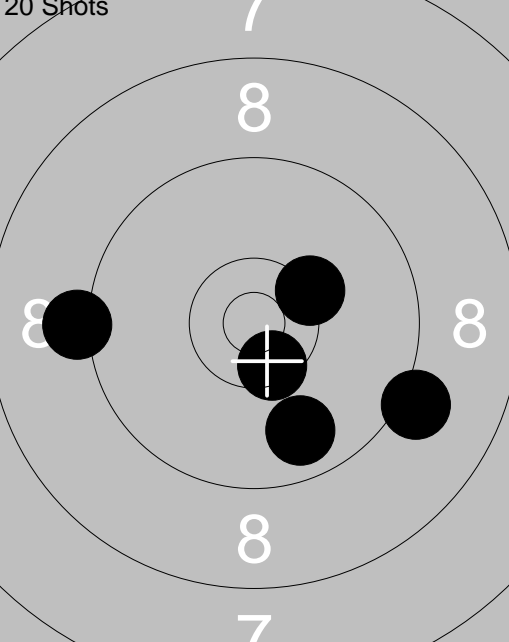
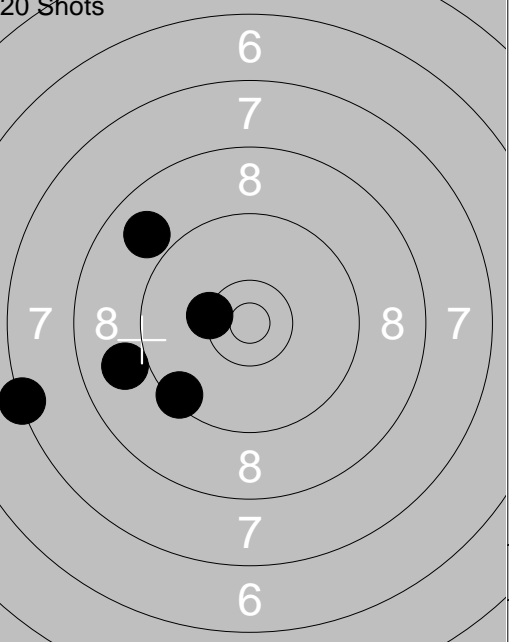
<p>20 Shots</p> 	<p>20 Shots</p> 	<p>6: *10.3 →</p> <p>7: 9.1 →</p> <p>8: 9.2 ←</p> <p>9: 9.8 ↓</p> <p>10: *10.5 ↓</p> <hr/> <p>Series 47.0</p> <p>Total 96.0</p>	<p>11: 8.9 ↖</p> <p>12: 7.3 ←</p> <p>13: 9.0 ←</p> <p>14: *10.3 ↖</p> <p>15: 9.4 ↙</p> <hr/> <p>Series 43.0</p> <p>Total 139.0</p>
---	---	---	--

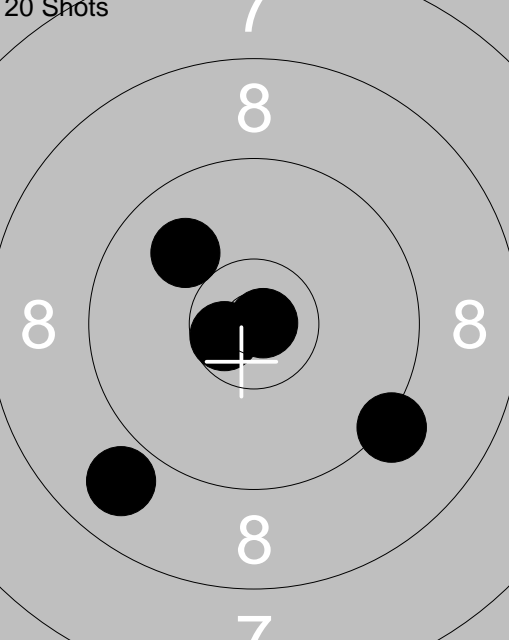
<p>20 Shots</p> 	<p>16: *10.6 ↖</p> <p>17: 9.2 ↘</p> <p>18: 8.9 ↙</p> <p>19: 10.0 ↖</p> <p>20: *10.9 →</p> <hr/> <p>Series 47.0</p> <p>Total 186.0</p>		
--	---	--	--

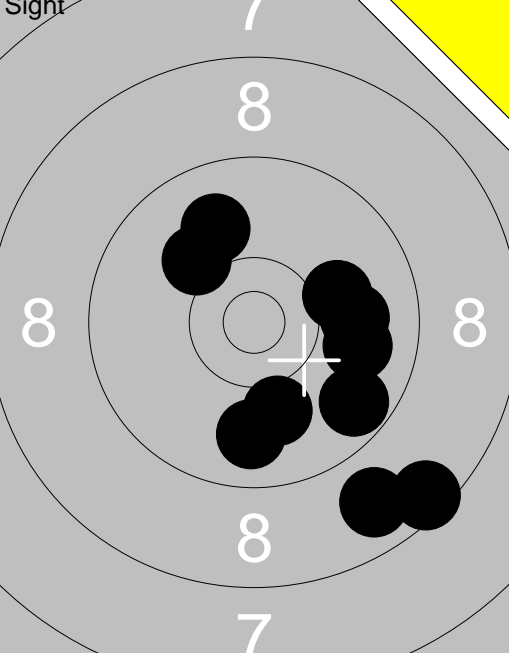
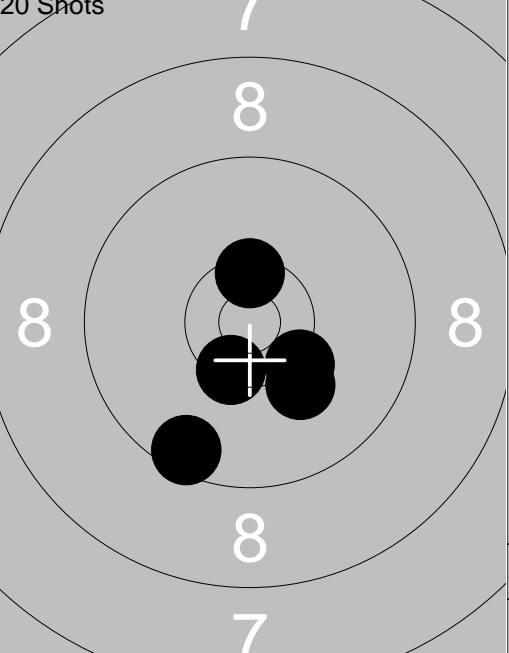
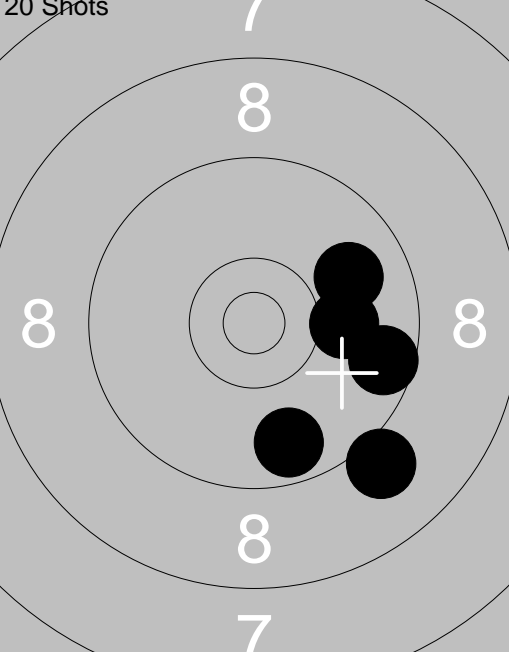
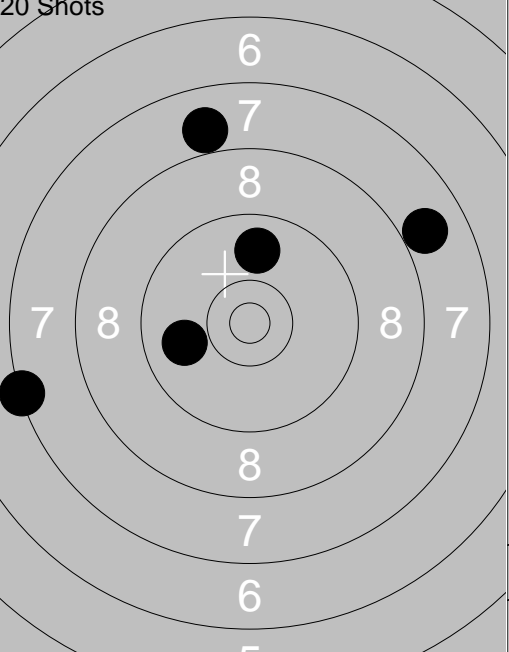
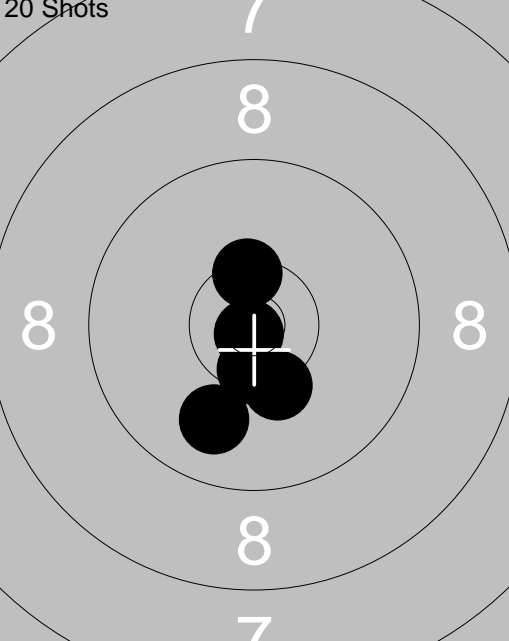
<p>Sight</p> 	<p>20 Shots</p> 	<p>1: 9.8 ↓</p> <p>2: 8.8 ↓</p> <p>3: 8.5 ↓</p> <p>4: 10.0 ↓</p> <p>5: 9.9 →</p> <p>6: 9.9 →</p> <p>7: 9.9 ↗</p> <p>8: 10.1 ↗</p> <p>9: 9.7 ↓</p> <p>10: 10.1 →</p> <hr/> <p>Series 91.0</p> <p>Total 0.0</p>	<p>1: 9.5 ↓</p> <p>2: *10.4 ↓</p> <p>3: *10.3 ↘</p> <p>4: 10.1 ↓</p> <p>5: *10.5 ↑</p> <hr/> <p>Series 49.0</p> <p>Total 49.0</p>
<p>20 Shots</p> 	<p>20 Shots</p> 	<p>6: 9.9 ↗</p> <p>7: 9.6 →</p> <p>8: 9.1 ↓</p> <p>9: 9.7 ↓</p> <p>10: 10.1 →</p> <hr/> <p>Series 46.0</p> <p>Total 95.0</p>	<p>11: 7.9 ↗</p> <p>12: 7.9 ↑</p> <p>13: 9.9 ←</p> <p>14: 9.8 ↑</p> <p>15: 7.3 ←</p> <hr/> <p>Series 39.0</p> <p>Total 134.0</p>
<p>20 Shots</p> 		<p>16: *10.8 ↓</p> <p>17: *10.4 ↑</p> <p>18: 9.9 ↓</p> <p>19: *10.3 ↓</p> <p>20: *10.5 ↓</p> <hr/> <p>Series 49.0</p> <p>Total 183.0</p>	

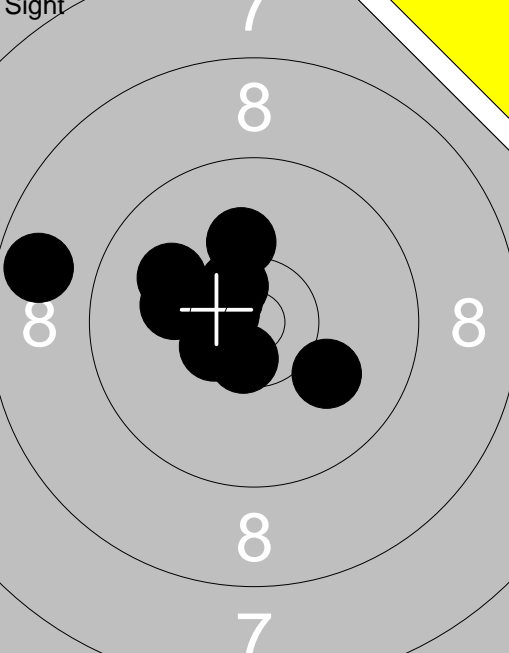
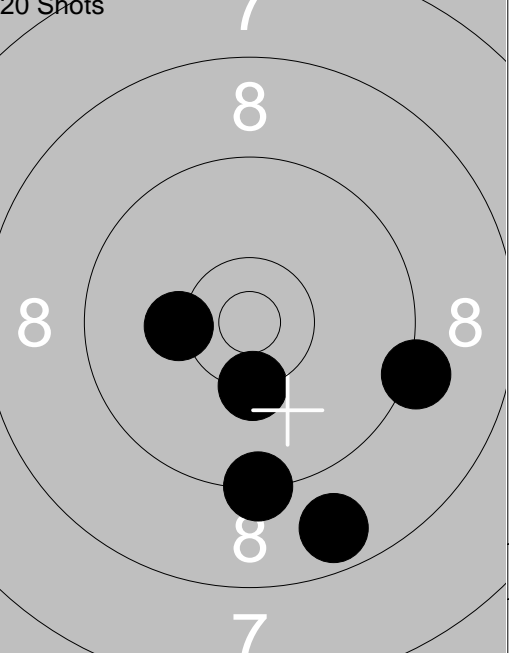
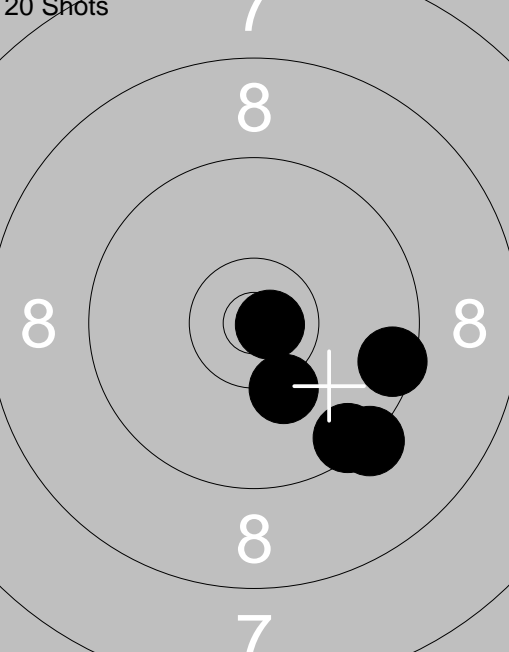
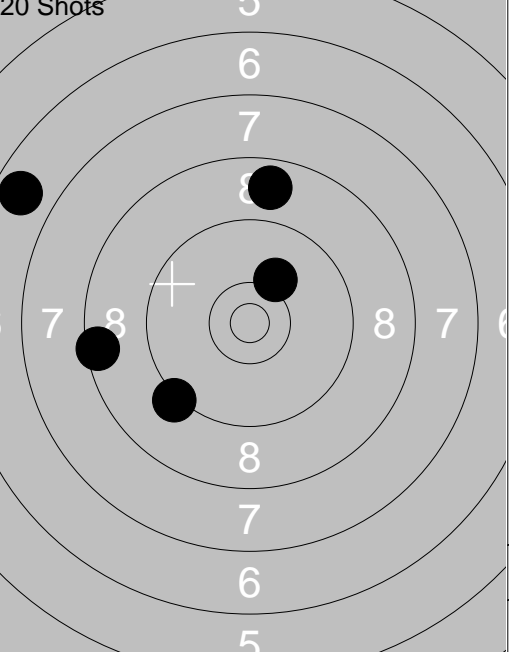
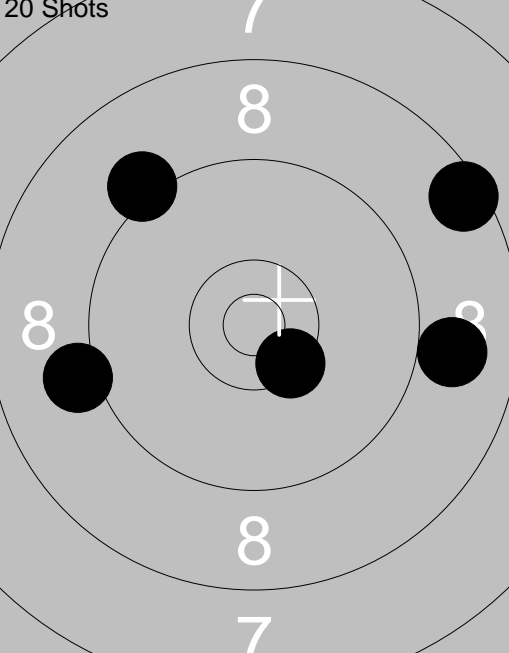
<p>Sight</p> 	<p>20 Shots</p> 	<p>1: 10.1 ↑</p> <p>2: 8.7 ←</p> <p>3: *10.6 ↘</p> <p>4: *10.6 ↘</p> <p>5: 10.1 ↘</p> <p>6: 10.0 ↖</p> <p>7: *10.5 ↘</p> <p>8: 10.1 ←</p> <p>9: *10.6 ↓</p> <p>10: *10.5 ↖</p> <hr/> <p>Series 98.0</p> <p>Total 0.0</p>	<p>1: 9.2 →</p> <p>2: 8.7 ↓</p> <p>3: *10.3 ↓</p> <p>4: 9.3 ↓</p> <p>5: 10.2 ←</p> <hr/> <p>Series 46.0</p> <p>Total 46.0</p>
<p>20 Shots</p> 	<p>20 Shots</p> 	<p>6: *10.8 →</p> <p>7: 9.5 ↓</p> <p>8: 10.2 ↓</p> <p>9: 9.3 ↓</p> <p>10: 9.5 →</p> <hr/> <p>Series 47.0</p> <p>Total 93.0</p>	<p>11: 8.5 ←</p> <p>12: 9.2 ↘</p> <p>13: 10.1 ↗</p> <p>14: 8.8 ↑</p> <p>15: 6.7 ↖</p> <hr/> <p>Series 41.0</p> <p>Total 134.0</p>
<p>20 Shots</p> 	<p>16: 9.0 →</p> <p>17: 9.1 ←</p> <p>18: *10.4 ↘</p> <p>19: 8.5 ↗</p> <p>20: 9.2 ↖</p> <hr/> <p>Series 45.0</p> <p>Total 179.0</p>		

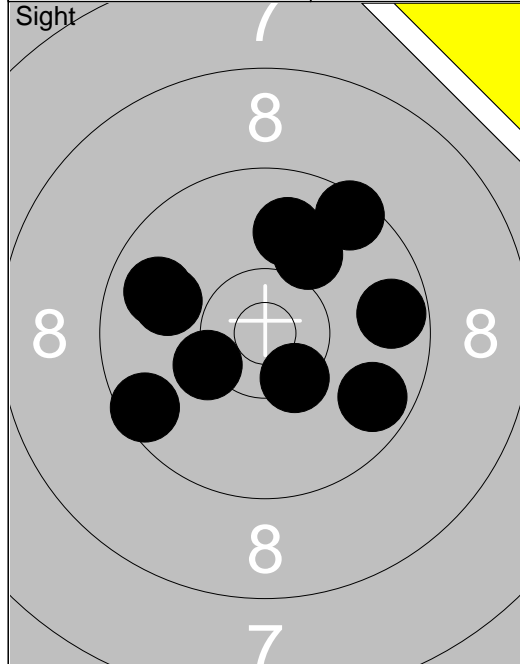

1:	*10.3 ↘
2:	9.9 ←
3:	9.5 ↙
4:	9.8 ←
5:	*10.4 ↘
6:	10.1 ↗
7:	9.7 →
8:	9.9 ↑
9:	9.7 ↘
10:	9.5 ↗
Series 93.0	
Total 0.0	

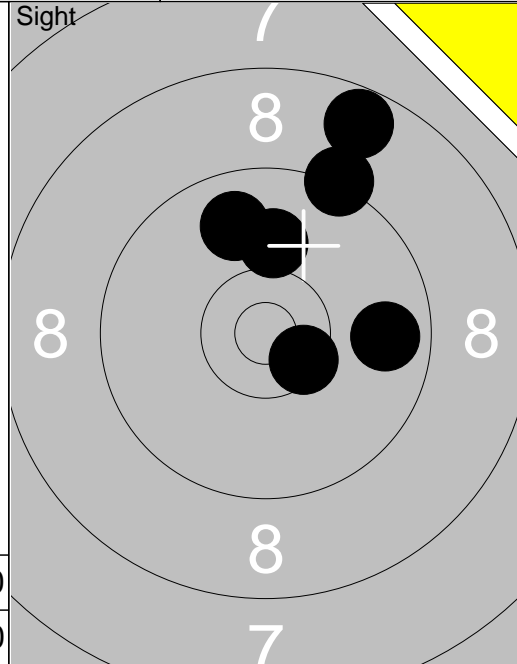

11:	9.3 ↗
12:	*10.5 ↘
13:	8.7 ↗
14:	10.0 ↑
15:	9.8 ↑
16:	9.8 →
Series 55.0	
Total 0.0	

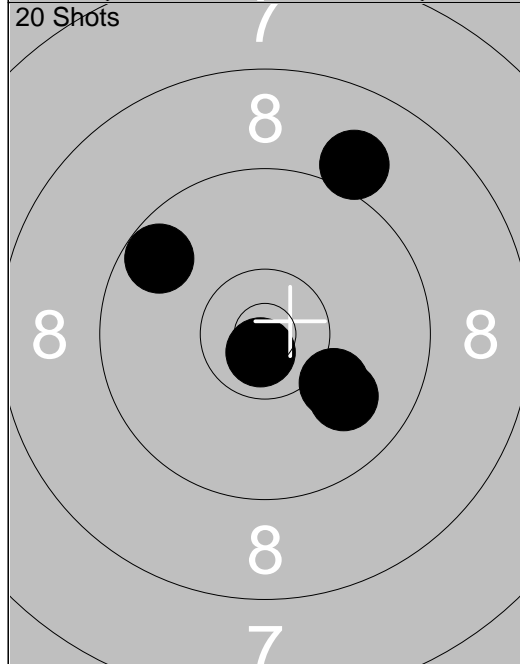

1:	10.1 ↘
2:	9.9 ↘
3:	*10.8 ↘
4:	9.7 ↙
5:	9.0 ↗
Series 47.0	
Total 47.0	

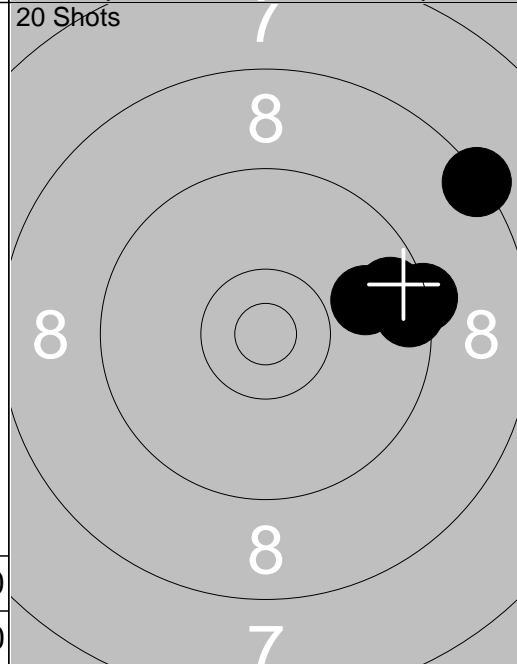

6:	9.3 →
7:	9.6 →
8:	8.4 ↗
9:	9.5 →
10:	9.9 →
Series 44.0	
Total 91.0	

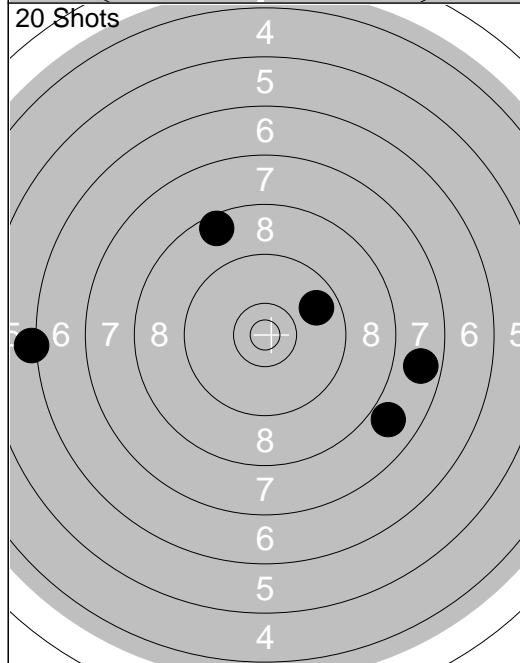

11:	6.2 ←
12:	8.6 ↗
13:	7.9 ↘
14:	7.7 →
15:	9.8 ↗
Series 37.0	
Total 128.0	

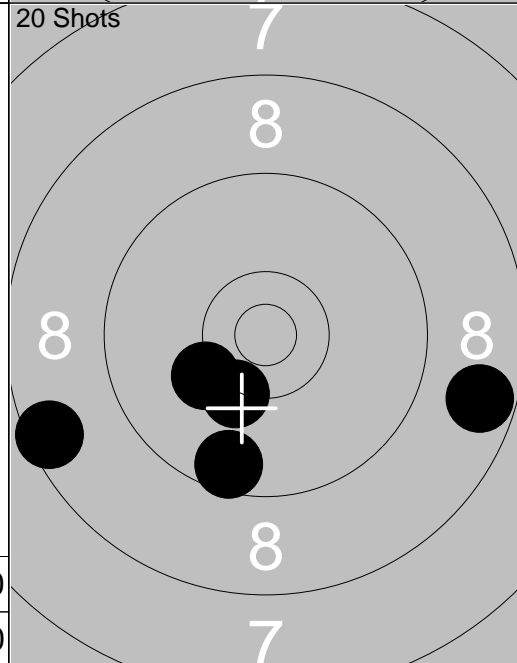

16:	8.7 →
17:	9.6 ↘
18:	10.3 ↘
19:	8.5 ←
20:	10.2 ↙
Series 45.0	
Total 173.0	

<p>Sight</p>	<p>20 Shots</p>	<table style="width:100%; border-collapse: collapse;"> <tr><td>1: 10.0 ↑</td><td>1: 9.4 ↓</td></tr> <tr><td>2: 7.8 ↑</td><td>2: 9.9 →</td></tr> <tr><td>3: 8.7 ↗</td><td>3: 9.6 →</td></tr> <tr><td>4: 9.3 →</td><td>4: 9.5 ↑</td></tr> <tr><td>5: 9.8 ↘</td><td>5: *10.8 ↗</td></tr> <tr><td>6: 9.6 ←</td><td></td></tr> <tr><td>7: 9.5 ←</td><td></td></tr> <tr><td>8: *10.3 ↗</td><td></td></tr> <tr><td>9: 9.1 ↑</td><td></td></tr> <tr><td>10: *10.4 ↘</td><td></td></tr> <tr><td colspan="2">Series 90.0</td></tr> <tr><td colspan="2">Total 0.0</td></tr> </table>	1: 10.0 ↑	1: 9.4 ↓	2: 7.8 ↑	2: 9.9 →	3: 8.7 ↗	3: 9.6 →	4: 9.3 →	4: 9.5 ↑	5: 9.8 ↘	5: *10.8 ↗	6: 9.6 ←		7: 9.5 ←		8: *10.3 ↗		9: 9.1 ↑		10: *10.4 ↘		Series 90.0		Total 0.0	
1: 10.0 ↑	1: 9.4 ↓																									
2: 7.8 ↑	2: 9.9 →																									
3: 8.7 ↗	3: 9.6 →																									
4: 9.3 →	4: 9.5 ↑																									
5: 9.8 ↘	5: *10.8 ↗																									
6: 9.6 ←																										
7: 9.5 ←																										
8: *10.3 ↗																										
9: 9.1 ↑																										
10: *10.4 ↘																										
Series 90.0																										
Total 0.0																										

<p>20 Shots</p>	<p>20 Shots</p>	<table style="width:100%; border-collapse: collapse;"> <tr><td>6: 9.6 ↗</td><td>11: 9.3 ←</td></tr> <tr><td>7: 9.9 →</td><td>12: 8.1 ←</td></tr> <tr><td>8: 9.9 →</td><td>13: 8.4 →</td></tr> <tr><td>9: 9.3 ↑</td><td>14: 9.5 ↗</td></tr> <tr><td>10: 9.9 ↘</td><td>15: 6.7 ↖</td></tr> <tr><td colspan="2">Series 45.0</td></tr> <tr><td colspan="2">Total 91.0</td></tr> </table>	6: 9.6 ↗	11: 9.3 ←	7: 9.9 →	12: 8.1 ←	8: 9.9 →	13: 8.4 →	9: 9.3 ↑	14: 9.5 ↗	10: 9.9 ↘	15: 6.7 ↖	Series 45.0		Total 91.0	
6: 9.6 ↗	11: 9.3 ←															
7: 9.9 →	12: 8.1 ←															
8: 9.9 →	13: 8.4 →															
9: 9.3 ↑	14: 9.5 ↗															
10: 9.9 ↘	15: 6.7 ↖															
Series 45.0																
Total 91.0																

<p>20 Shots</p>	<p>20 Shots</p>	<table style="width:100%; border-collapse: collapse;"> <tr><td>16: 10.2 ↑</td><td></td></tr> <tr><td>17: 9.4 ↖</td><td></td></tr> <tr><td>18: 8.3 ←</td><td></td></tr> <tr><td>19: 9.5 ↓</td><td></td></tr> <tr><td>20: 9.6 ↘</td><td></td></tr> <tr><td colspan="2">Series 45.0</td></tr> <tr><td colspan="2">Total 176.0</td></tr> </table>	16: 10.2 ↑		17: 9.4 ↖		18: 8.3 ←		19: 9.5 ↓		20: 9.6 ↘		Series 45.0		Total 176.0	
16: 10.2 ↑																
17: 9.4 ↖																
18: 8.3 ←																
19: 9.5 ↓																
20: 9.6 ↘																
Series 45.0																
Total 176.0																

<p>Sight</p> 	<p>20 Shots</p> 	<table style="width:100%; border-collapse: collapse;"> <tr><td>1: 8.7 →</td><td>1: 10.2 ↘</td></tr> <tr><td>2: 10.0 →</td><td>2: *10.4 ↘</td></tr> <tr><td>3: 9.8 ↘</td><td>3: *10.7 ↗</td></tr> <tr><td>4: *10.3 ↘</td><td>4: 8.9 ↗</td></tr> <tr><td>5: 9.9 ↘</td><td>5: 9.8 ↗</td></tr> <tr><td>6: 9.5 ↘</td><td></td></tr> <tr><td>7: 9.9 ↘</td><td></td></tr> </table>	1: 8.7 →	1: 10.2 ↘	2: 10.0 →	2: *10.4 ↘	3: 9.8 ↘	3: *10.7 ↗	4: *10.3 ↘	4: 8.9 ↗	5: 9.9 ↘	5: 9.8 ↗	6: 9.5 ↘		7: 9.9 ↘	
1: 8.7 →	1: 10.2 ↘															
2: 10.0 →	2: *10.4 ↘															
3: 9.8 ↘	3: *10.7 ↗															
4: *10.3 ↘	4: 8.9 ↗															
5: 9.9 ↘	5: 9.8 ↗															
6: 9.5 ↘																
7: 9.9 ↘																
Series 64.0	Series 47.0															
Total 0.0	Total 47.0															

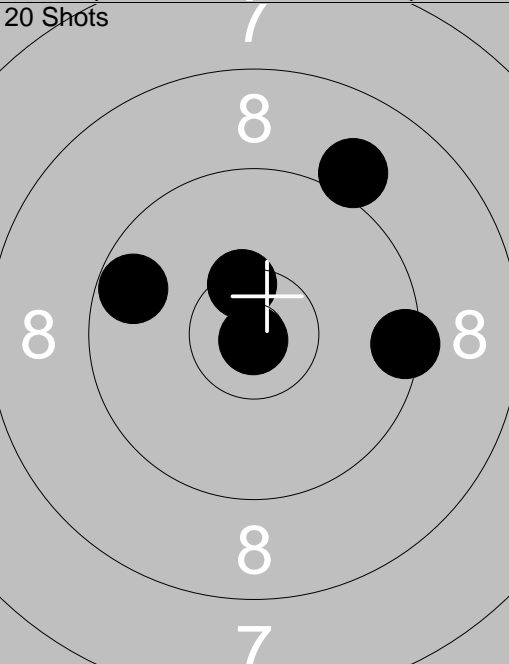
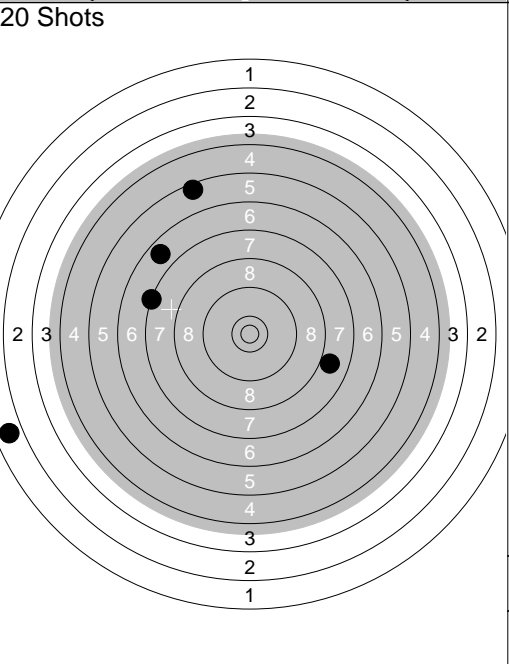
<p>20 Shots</p> 	<p>20 Shots</p> 	<table style="width:100%; border-collapse: collapse;"> <tr><td>6: 9.1 ↗</td><td>11: 5.5 ↗</td></tr> <tr><td>7: 9.4 →</td><td>12: 1.8 ←</td></tr> <tr><td>8: *10.4 ↗</td><td>13: 6.8 ↗</td></tr> <tr><td>9: *10.9 ↘</td><td>14: 7.3 ←</td></tr> <tr><td>10: 9.7 ←</td><td>15: 7.9 →</td></tr> </table>	6: 9.1 ↗	11: 5.5 ↗	7: 9.4 →	12: 1.8 ←	8: *10.4 ↗	13: 6.8 ↗	9: *10.9 ↘	14: 7.3 ←	10: 9.7 ←	15: 7.9 →
6: 9.1 ↗	11: 5.5 ↗											
7: 9.4 →	12: 1.8 ←											
8: *10.4 ↗	13: 6.8 ↗											
9: *10.9 ↘	14: 7.3 ←											
10: 9.7 ←	15: 7.9 →											
Series 47.0	Series 26.0											
Total 94.0	Total 120.0											

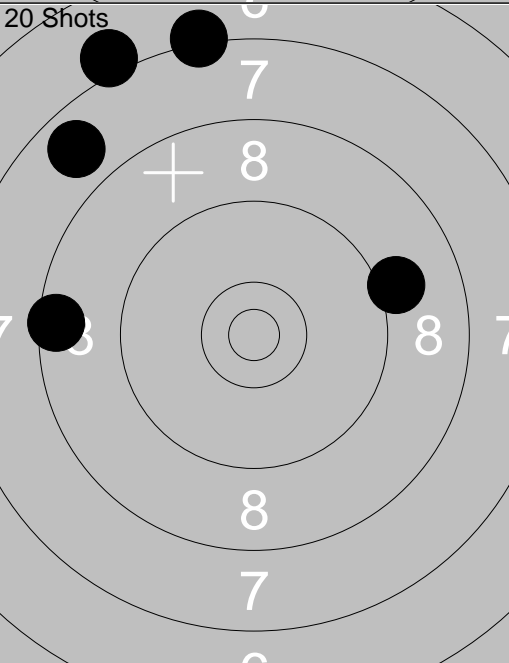
<p>20 Shots</p> 	<table style="width:100%; border-collapse: collapse;"> <tr><td>16: 7.2 ↗</td></tr> <tr><td>17: 9.1 →</td></tr> <tr><td>18: 7.1 ↗</td></tr> <tr><td>19: 7.8 ↗</td></tr> <tr><td>20: 8.5 ←</td></tr> </table>	16: 7.2 ↗	17: 9.1 →	18: 7.1 ↗	19: 7.8 ↗	20: 8.5 ←	
16: 7.2 ↗							
17: 9.1 →							
18: 7.1 ↗							
19: 7.8 ↗							
20: 8.5 ←							
Series 38.0							
Total 158.0							

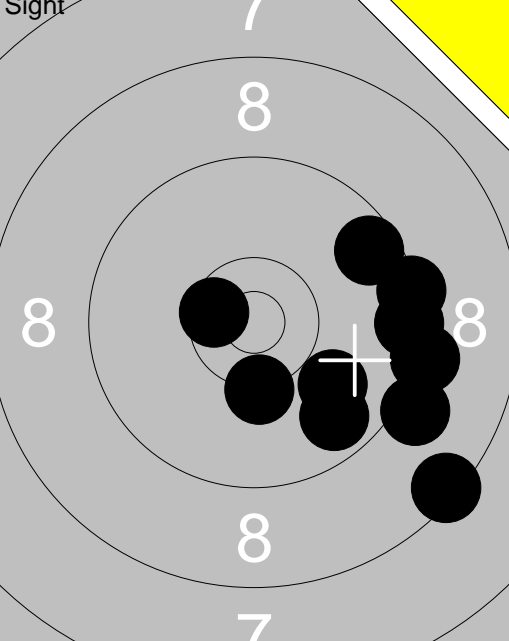
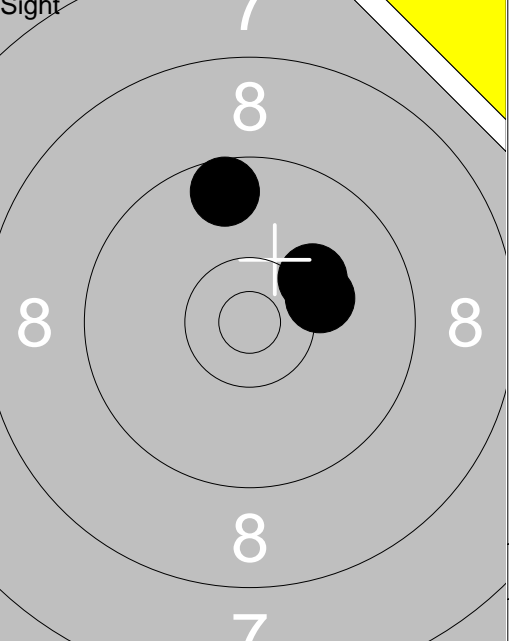
<p>Sight</p> 	<p>Sight</p> 	<table style="width:100%; border-collapse: collapse;"> <tr><td>1: 9.7 ↘</td><td>11: 10.2 ↗</td></tr> <tr><td>2: 9.4 →</td><td>12: 9.6 ↑</td></tr> <tr><td>3: 10.0 ↘</td><td>13: 10.2 →</td></tr> <tr><td>4: 9.2 →</td><td></td></tr> <tr><td>5: 8.4 ↘</td><td></td></tr> <tr><td>6: *10.5 ←</td><td></td></tr> <tr><td>7: 9.3 →</td><td></td></tr> <tr><td>8: 10.3 ↓</td><td></td></tr> <tr><td>9: 9.6 ↗</td><td></td></tr> <tr><td>10: 9.1 ↘</td><td></td></tr> <tr><td colspan="2">Series 92.0</td></tr> <tr><td colspan="2">Total 0.0</td></tr> </table>	1: 9.7 ↘	11: 10.2 ↗	2: 9.4 →	12: 9.6 ↑	3: 10.0 ↘	13: 10.2 →	4: 9.2 →		5: 8.4 ↘		6: *10.5 ←		7: 9.3 →		8: 10.3 ↓		9: 9.6 ↗		10: 9.1 ↘		Series 92.0		Total 0.0	
1: 9.7 ↘	11: 10.2 ↗																									
2: 9.4 →	12: 9.6 ↑																									
3: 10.0 ↘	13: 10.2 →																									
4: 9.2 →																										
5: 8.4 ↘																										
6: *10.5 ←																										
7: 9.3 →																										
8: 10.3 ↓																										
9: 9.6 ↗																										
10: 9.1 ↘																										
Series 92.0																										
Total 0.0																										

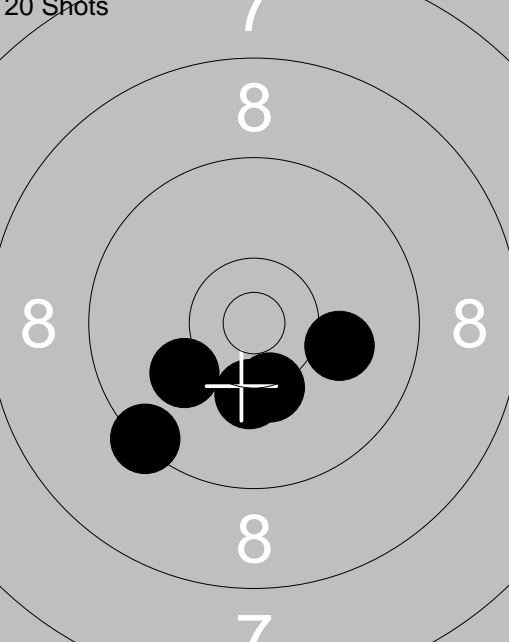
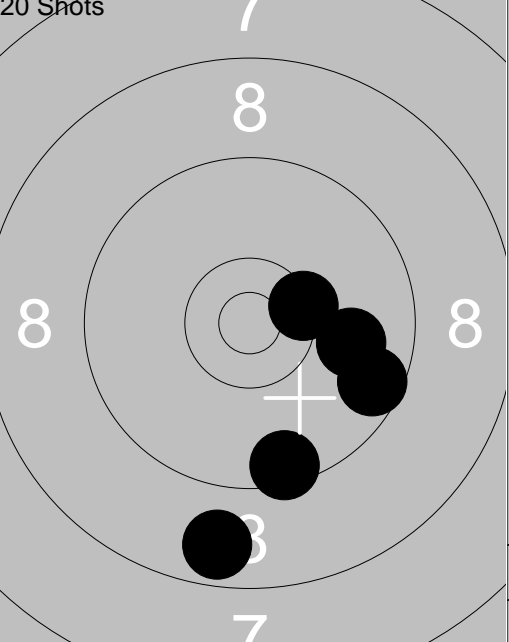
<p>20 Shots</p> 	<p>20 Shots</p> 	<table style="width:100%; border-collapse: collapse;"> <tr><td>1: 9.4 ↘</td><td>6: 9.5 ↓</td></tr> <tr><td>2: 10.2 ↓</td><td>7: 9.6 →</td></tr> <tr><td>3: 10.1 ↙</td><td>8: *10.4 →</td></tr> <tr><td>4: 10.1 →</td><td>9: 9.9 →</td></tr> <tr><td>5: *10.3 ↓</td><td>10: 8.7 ↓</td></tr> <tr><td colspan="2">Series 49.0</td></tr> <tr><td colspan="2">Total 49.0</td></tr> </table>	1: 9.4 ↘	6: 9.5 ↓	2: 10.2 ↓	7: 9.6 →	3: 10.1 ↙	8: *10.4 →	4: 10.1 →	9: 9.9 →	5: *10.3 ↓	10: 8.7 ↓	Series 49.0		Total 49.0	
1: 9.4 ↘	6: 9.5 ↓															
2: 10.2 ↓	7: 9.6 →															
3: 10.1 ↙	8: *10.4 →															
4: 10.1 →	9: 9.9 →															
5: *10.3 ↓	10: 8.7 ↓															
Series 49.0																
Total 49.0																

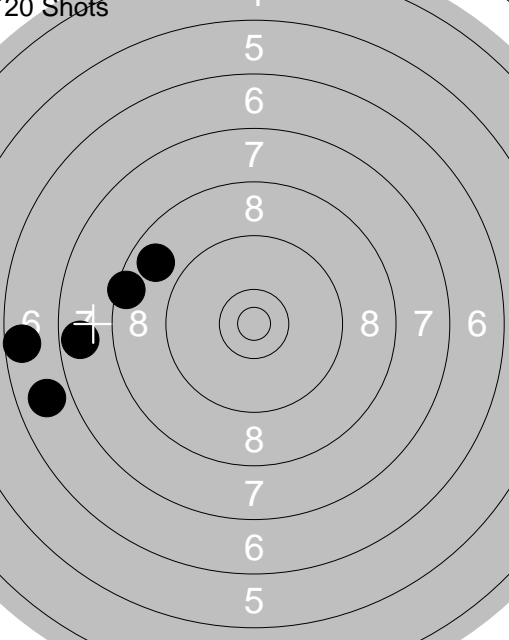
<p>20 Shots</p> 	<p>20 Shots</p> 	<table style="width:100%; border-collapse: collapse;"> <tr><td>11: 8.8 ↙</td><td>16: *10.4 →</td></tr> <tr><td>12: 6.6 ←</td><td>17: 10.2 ↗</td></tr> <tr><td>13: 6.9 ←</td><td>18: 6.7 →</td></tr> <tr><td>14: 7.7 ←</td><td>19: 9.6 →</td></tr> <tr><td>15: 8.5 ←</td><td>20: 8.0 →</td></tr> <tr><td colspan="2">Series 35.0</td></tr> <tr><td colspan="2">Total 129.0</td></tr> </table>	11: 8.8 ↙	16: *10.4 →	12: 6.6 ←	17: 10.2 ↗	13: 6.9 ←	18: 6.7 →	14: 7.7 ←	19: 9.6 →	15: 8.5 ←	20: 8.0 →	Series 35.0		Total 129.0	
11: 8.8 ↙	16: *10.4 →															
12: 6.6 ←	17: 10.2 ↗															
13: 6.9 ←	18: 6.7 →															
14: 7.7 ←	19: 9.6 →															
15: 8.5 ←	20: 8.0 →															
Series 35.0																
Total 129.0																

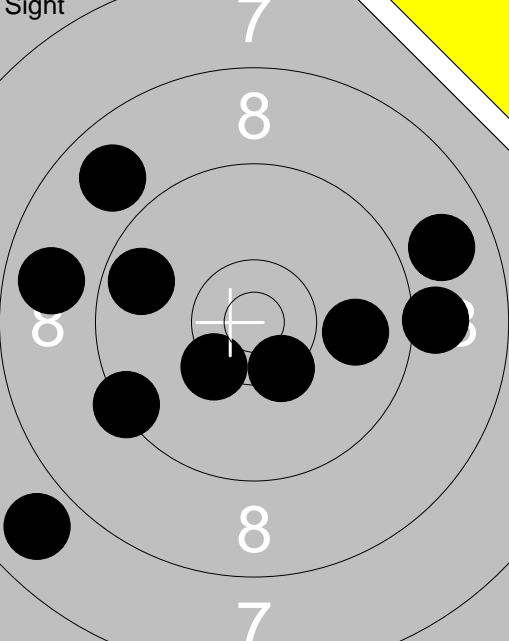
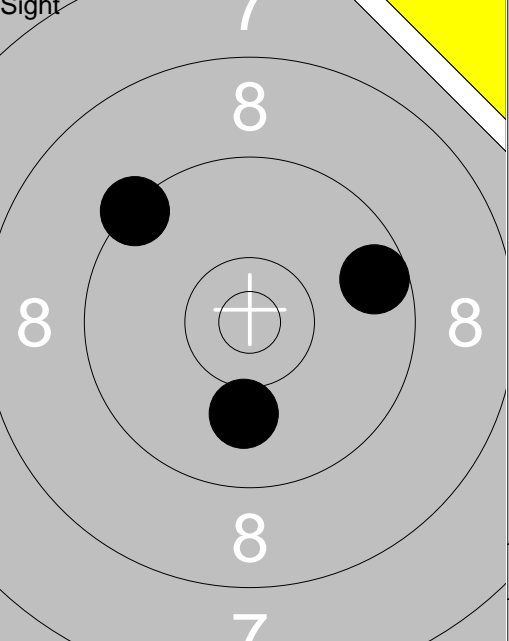
 <p>Sight</p>	<p>1: 7.8 ↙ 2: 8.8 ← 3: 8.8 → 4: 9.1 → 5: 9.9 → 6: 9.4 ↙ 7: *10.3 ↘ 8: *10.4 ↘ 9: 8.8 ↗ 10: 9.7 ←</p> <p>Series 87.0 Total 0.0</p>	 <p>Sight</p>	<p>11: 9.6 → 12: 9.4 ↖ 13: 10.0 ↓</p> <p>Series 28.0 Total 0.0</p>
---	--	---	--

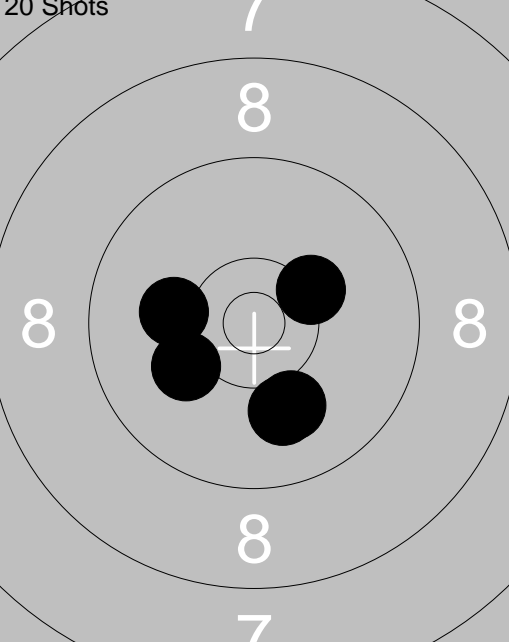
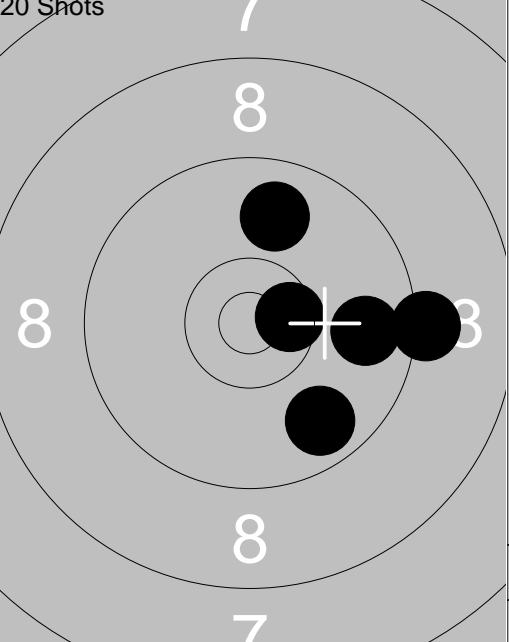
 <p>20 Shots</p>	<p>1: 10.0 ↓ 2: 10.1 ↙ 3: 10.1 ← 4: *10.3 → 5: 10.1 ↓</p> <p>Series 50.0 Total 50.0</p>	 <p>20 Shots</p>	<p>6: 9.8 → 7: *10.5 → 8: 9.9 ↑ 9: 9.7 ↓ 10: 9.2 →</p> <p>Series 46.0 Total 96.0</p>
---	---	---	--

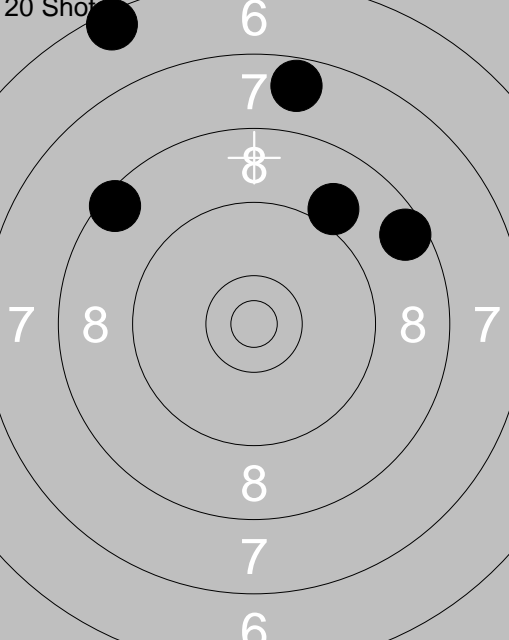
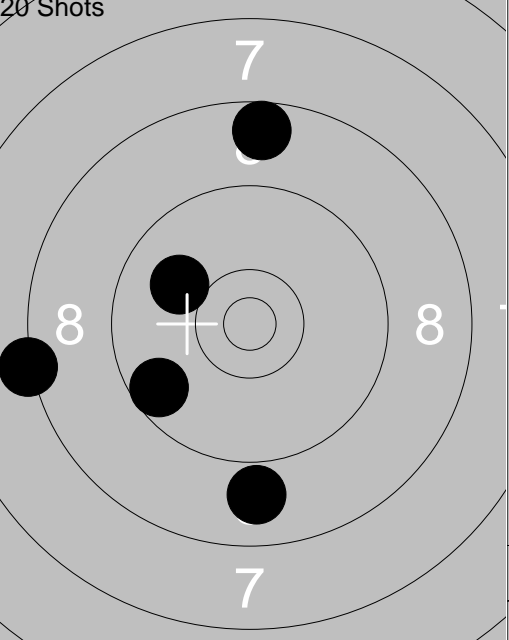
 <p>20 Shots</p>	<p>11: 7.7 ↑ 12: 9.1 ↗ 13: 8.5 ↖ 14: 8.6 → 15: 6.5 ↗</p> <p>Series 38.0 Total 134.0</p>	 <p>20 Shots</p>	<p>16: 10.0 ↖ 17: 8.9 ↓ 18: 8.6 ↑ 19: 8.3 ← 20: 9.6 ↙</p> <p>Series 43.0 Total 177.0</p>
--	---	--	--

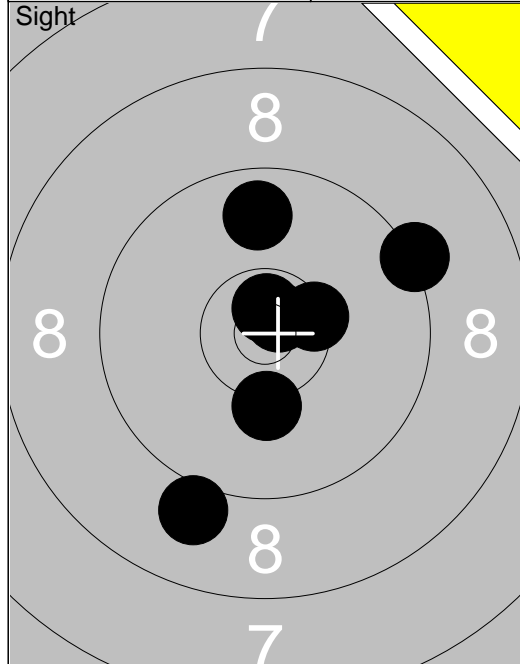

1: *10.7	↑
2: 9.0	↓
3: 9.3	→
4: *10.4	→
5: *10.7	↗
6: 9.8	↑
7: 10.2	↓
Series 67.0	
Total 0.0	

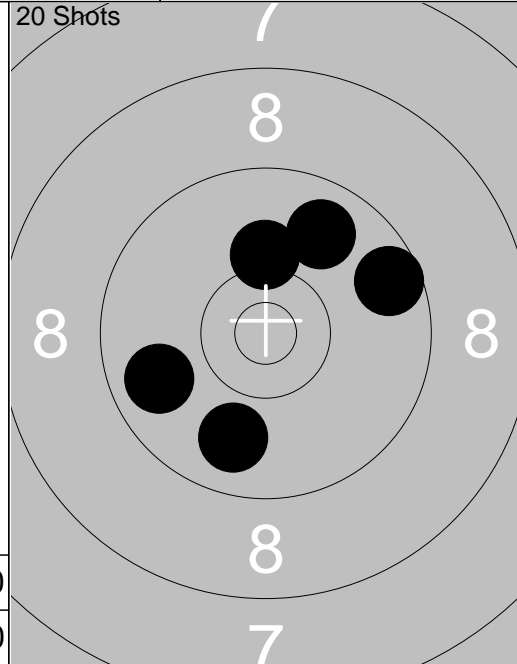

1: 9.8	↗
2: 9.9	↓
3: 9.6	→
4: 9.8	↙
5: 10.2	↑
Series 46.0	
Total 46.0	

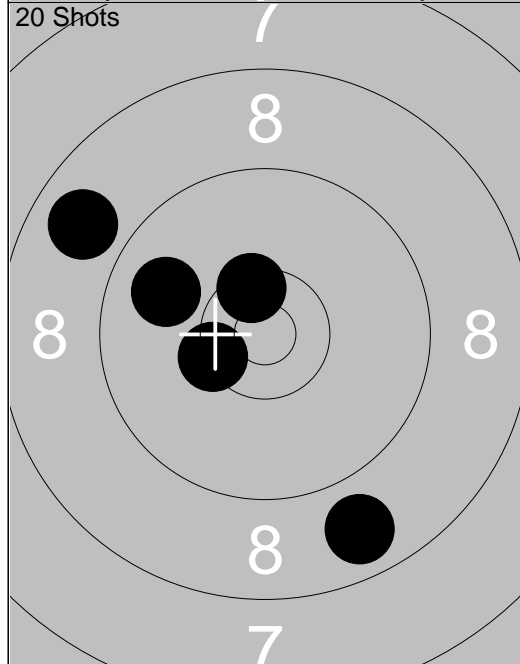

6: *10.4	↙
7: *10.5	↗
8: 8.8	↓
9: 8.8	↖
10: 9.9	↖
Series 45.0	
Total 91.0	

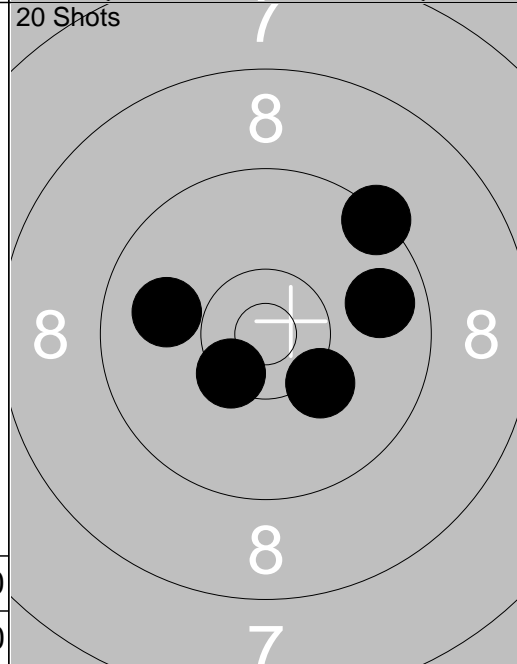

11: 9.8	→
12: *10.4	↙
13: 9.9	↖
14: 10.2	↘
15: 9.4	↗
Series 47.0	
Total 138.0	

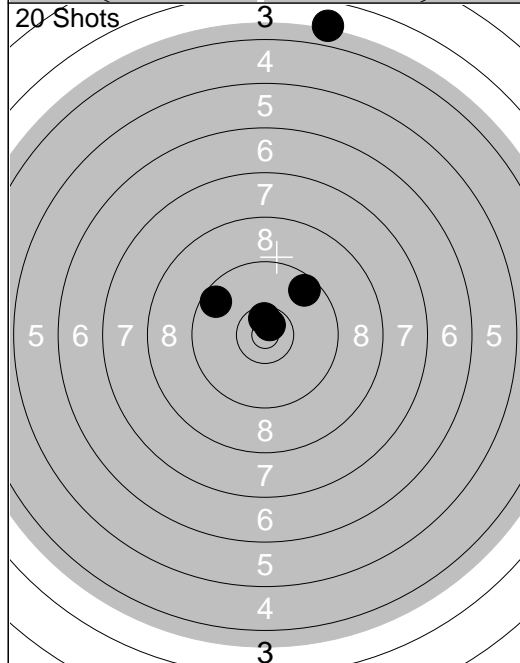

16: 9.6	↖
17: 9.6	↗
18: *10.7	↗
19: 3.9	↑
20: *10.6	↑
Series 41.0	
Total 179.0	

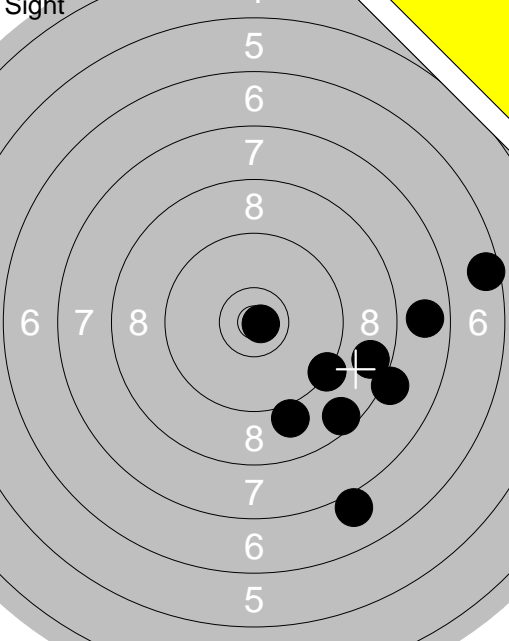
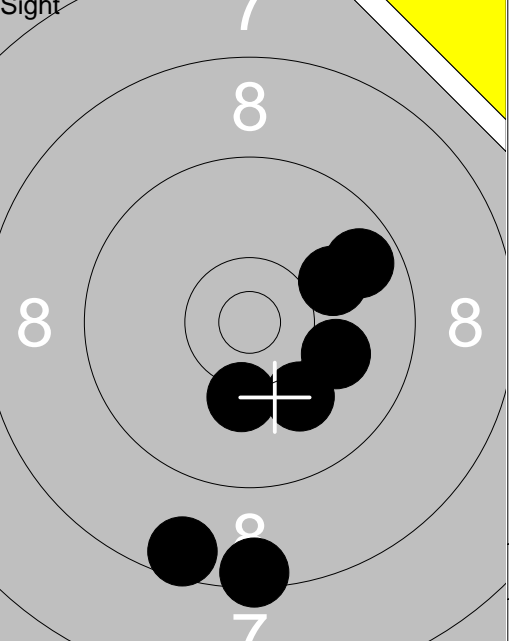
 <p>Sight</p>	<p>1: *10.8 →</p> <p>2: 6.6 →</p> <p>3: 7.1 ↓</p> <p>4: 9.0 ↓</p> <p>5: 8.6 ↓</p> <p>6: 9.3 ↓</p> <p>7: 8.2 ↓</p> <p>8: 8.7 →</p> <p>9: 9.3 ↓</p> <p>10: 7.8 →</p>	 <p>Sight</p>	<p>11: 10.1 ↓</p> <p>12: 8.6 ↓</p> <p>13: 10.0 →</p> <p>14: 9.7 ↗</p> <p>15: 10.2 ↓</p> <p>16: 8.5 ↓</p> <p>17: 10.0 ↗</p>
Series 81.0		Series 65.0	
Total 0.0		Total 0.0	

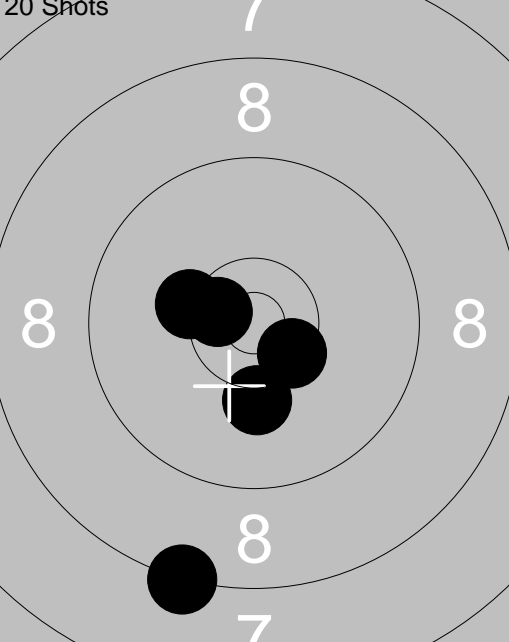
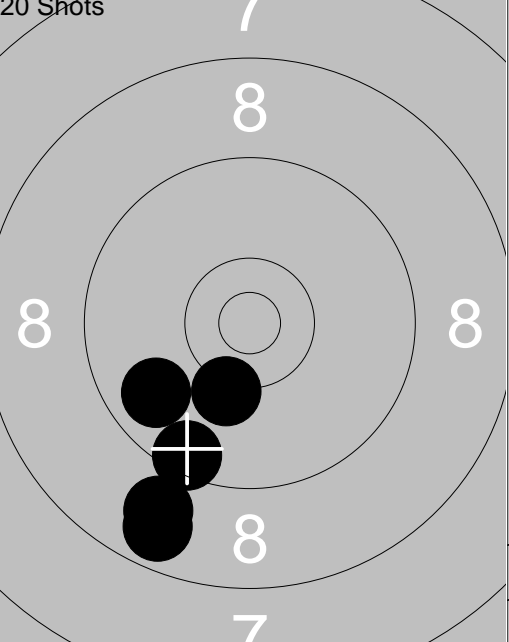
 <p>20 Shots</p>	<p>1: 10.3 ↖</p> <p>2: *10.6 ↖</p> <p>3: *10.5 ↘</p> <p>4: 10.2 ↓</p> <p>5: 8.3 ↓</p>	 <p>20 Shots</p>	<p>6: 9.5 ↓</p> <p>7: 9.8 ↖</p> <p>8: 8.9 ↓</p> <p>9: 8.7 ↓</p> <p>10: 10.2 ↓</p>
Series 48.0		Series 44.0	
Total 48.0		Total 92.0	

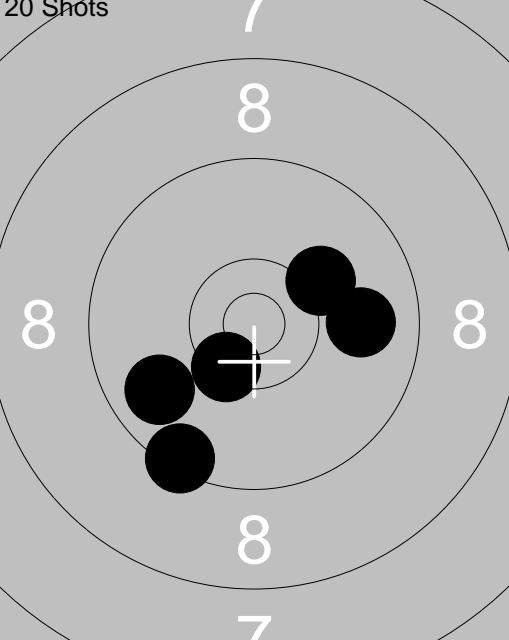
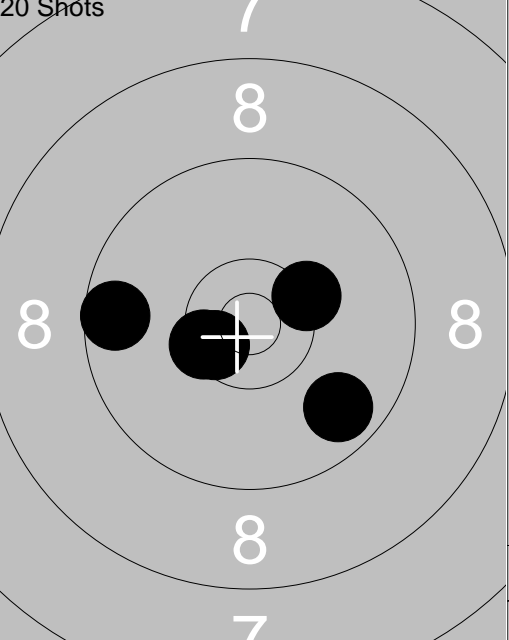
 <p>20 Shots</p>	<p>11: 9.9 →</p> <p>12: *10.4 ↘</p> <p>13: 10.2 ↗</p> <p>14: 9.8 ↖</p> <p>15: 9.4 ↓</p>	 <p>20 Shots</p>	<p>16: 9.7 ↓</p> <p>17: *10.5 ↘</p> <p>18: *10.3 ↗</p> <p>19: *10.4 ↖</p> <p>20: 9.6 ←</p>
Series 47.0		Series 48.0	
Total 139.0		Total 187.0	

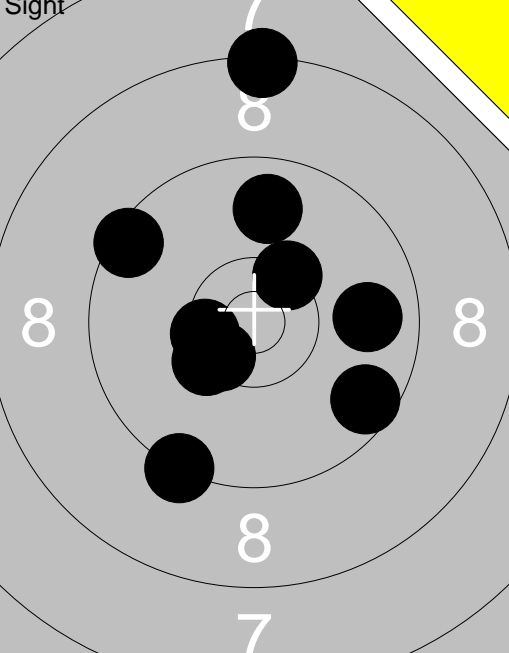
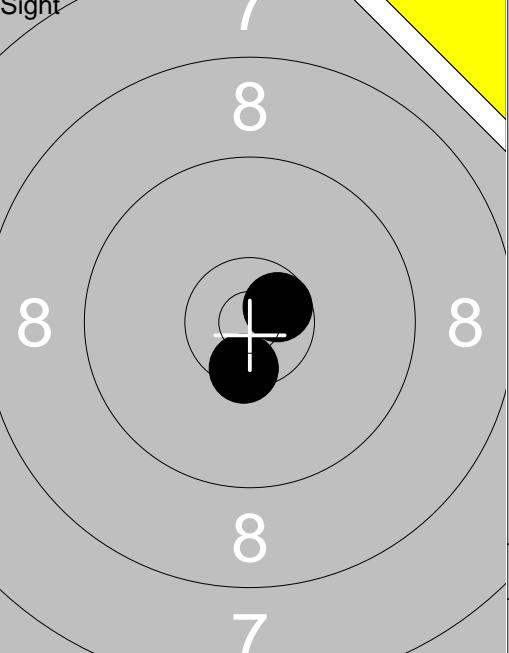
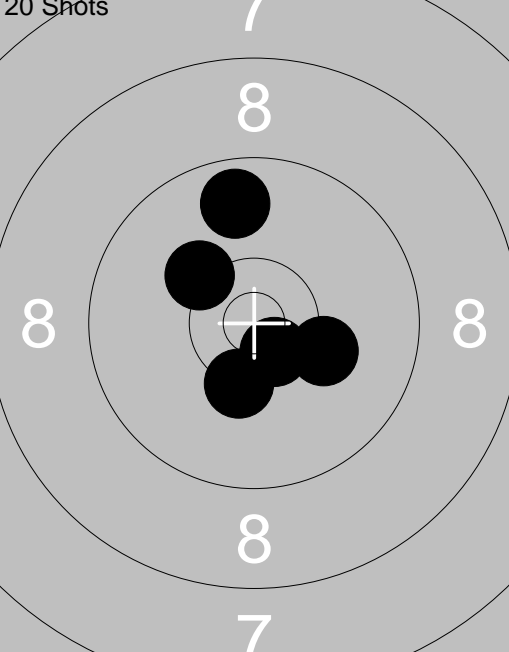
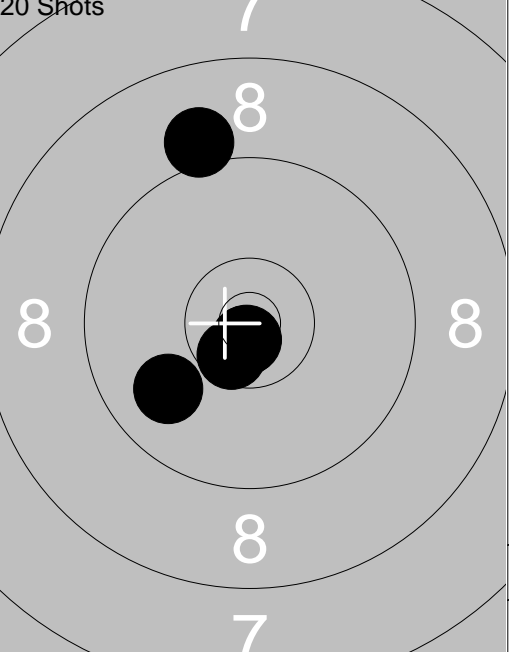
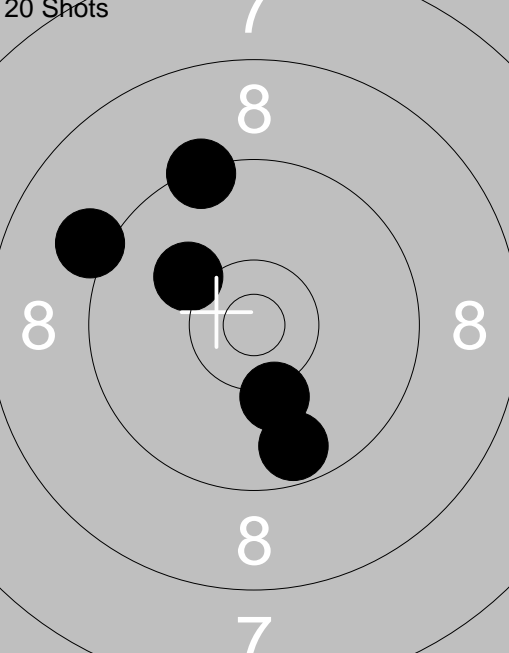
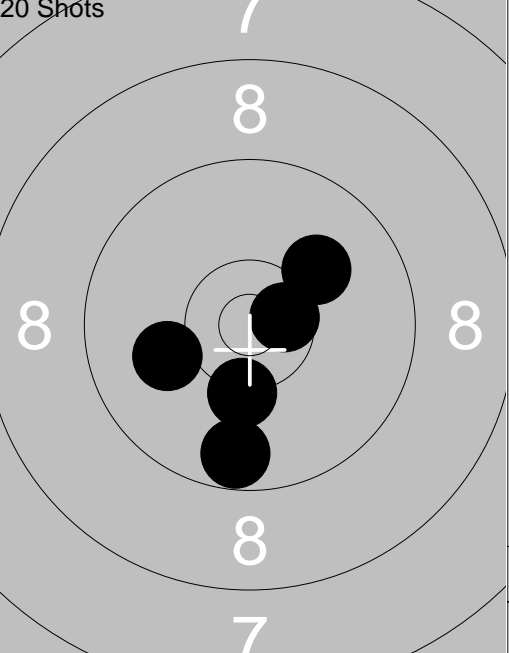
<p>Sight</p> 	<p>1: 8.4 ↑ 2: *10.4 ← 3: 9.5 ← 4: *10.5 ↓ 5: *10.4 ↗ 6: 9.8 → 7: 9.6 ↘ 8: *10.3 ↓ 9: 9.8 ↑ 10: 9.3 ↓</p> <p>Series 93.0 Total 0.0</p>	<p>Sight</p> 	<p>11: *10.6 ↗ 12: *10.5 ↓</p> <p>Series 20.0 Total 0.0</p>
<p>20 Shots</p> 	<p>1: *10.6 ↓ 2: *10.3 ↓ 3: 10.2 → 4: 9.7 ↑ 5: 10.2 ↖</p> <p>Series 49.0 Total 49.0</p>	<p>20 Shots</p> 	<p>6: *10.8 ↓ 7: *10.6 ↓ 8: *10.8 ↓ 9: 9.9 ← 10: 9.1 ↑</p> <p>Series 48.0 Total 97.0</p>
<p>20 Shots</p> 	<p>11: 9.1 ← 12: 10.2 ↓ 13: 9.7 ↓ 14: 10.1 ↖ 15: 9.4 ↑</p> <p>Series 47.0 Total 144.0</p>	<p>20 Shots</p> 	<p>16: 10.1 ↗ 17: 9.7 ↓ 18: *10.6 ↗ 19: 10.3 ↓ 20: 10.1 ←</p> <p>Series 49.0 Total 193.0</p>

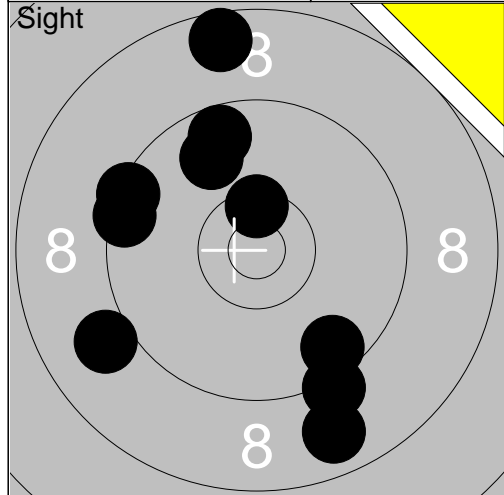

1:	8.8	↘
2:	9.2	↘
3:	9.8	↗
4:	9.4	↖
5:	8.6	↗
6:	9.5	↖
7:	*10.5	↗
8:	9.6	↗
9:	9.6	↘
10:	9.0	↖
Series		89.0
Total		0.0

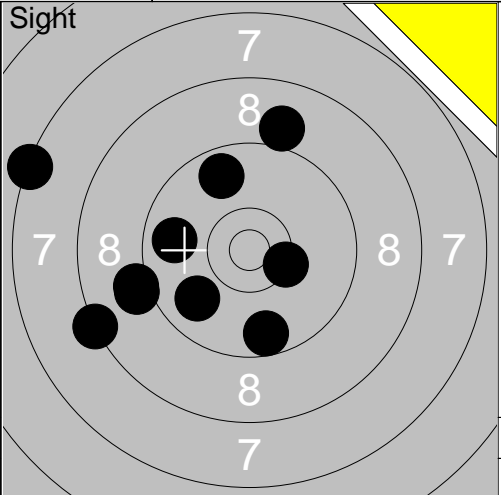

11:	9.8	←
12:	9.7	↗
13:	9.1	←
14:	9.7	↘
15:	9.9	↘
16:	9.1	←
17:	8.3	←
18:	7.4	↖
19:	9.0	↗
20:	*10.4	↘
Series		88.0
Total		0.0

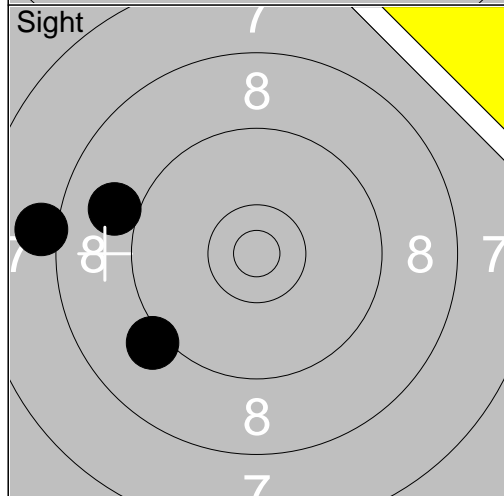

21:	9.0	←
22:	8.1	←
23:	9.1	↖
Series		26.0
Total		0.0

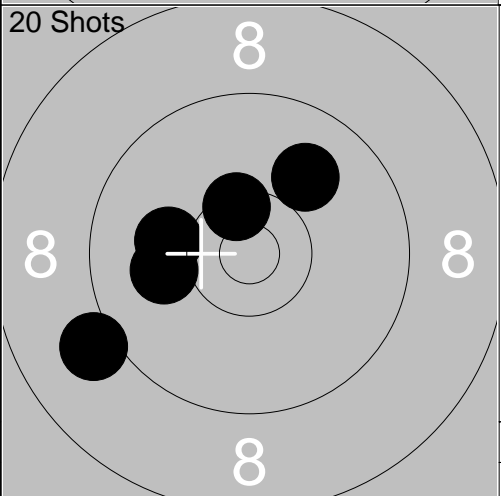

1:	10.1	←
2:	9.1	↖
3:	*10.4	↗
4:	10.0	↗
5:	10.1	←
Series		49.0
Total		49.0

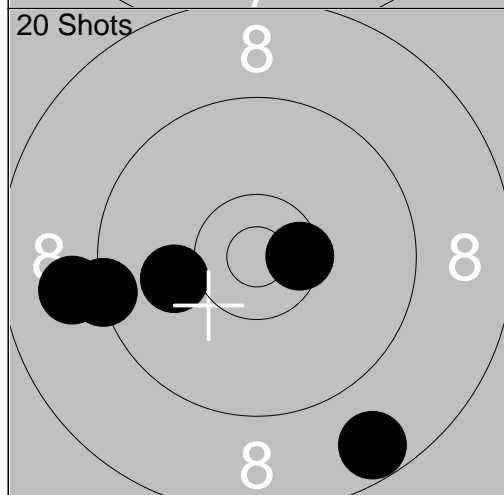

6:	8.7	↘
7:	*10.5	→
8:	9.0	←
9:	10.1	←
10:	9.3	←
Series		46.0
Total		95.0

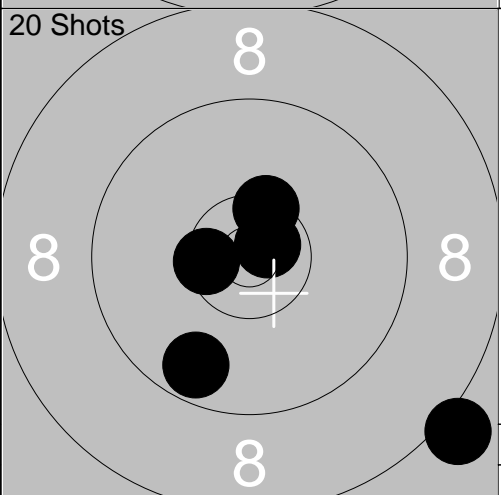

11:	*10.5	←
12:	9.7	↘
13:	*10.7	↗
14:	*10.4	↗
15:	8.1	↘
Series		47.0
Total		142.0

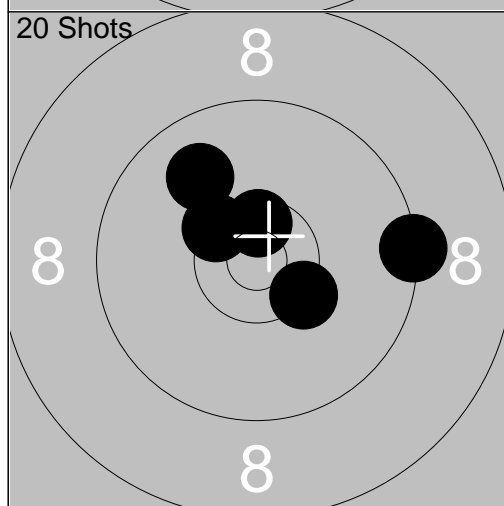

16:	9.3	→
17:	*10.4	↗
18:	*10.6	↗
19:	*10.3	↘
20:	9.9	↗
Series		48.0
Total		190.0

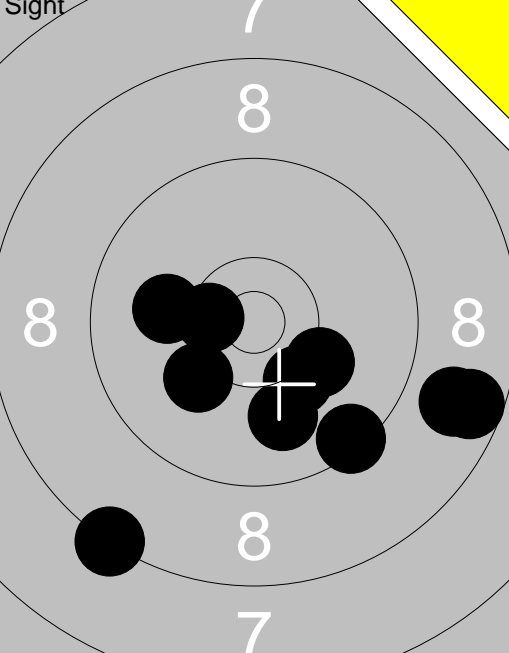
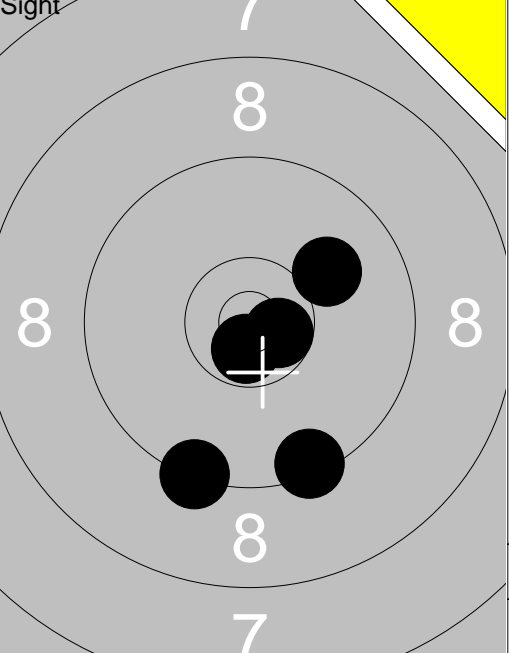
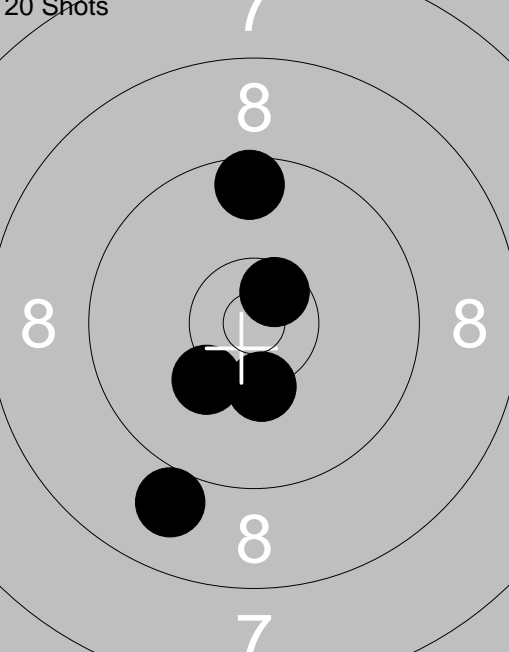
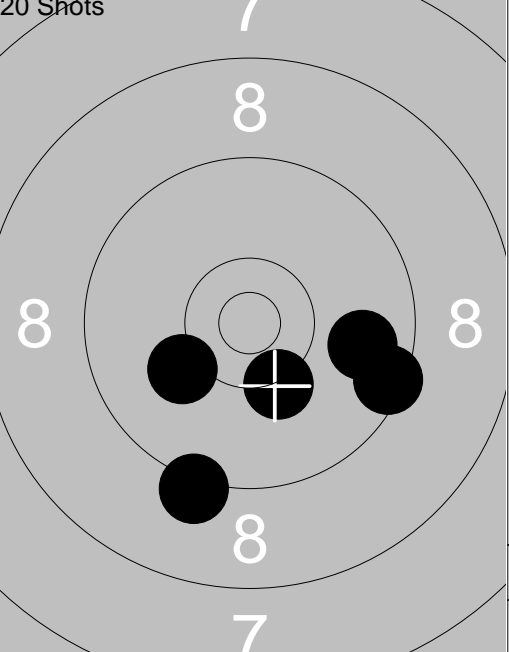
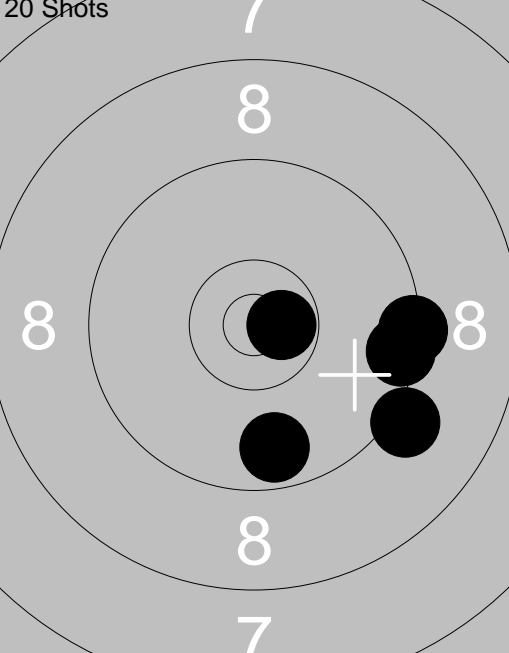
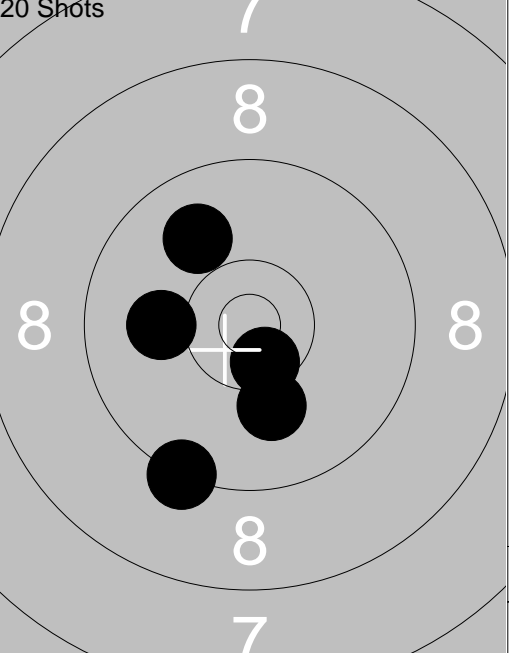
<p>Sight</p> 	<p>1: 10.1 ←</p> <p>2: 9.4 ↓</p> <p>3: 8.8 →</p> <p>4: 8.3 ↓</p> <p>5: 8.6 →</p> <p>6: 10.2 ↓</p> <p>7: 10.2 ↓</p> <p>8: 10.0 ↓</p> <p>9: 10.2 →</p> <p>10: *10.5 ←</p> <hr/> <p>Series 93.0</p> <hr/> <p>Total 0.0</p>	<p>Sight</p> 	<p>11: 10.0 ↗</p> <p>12: 9.4 ↓</p> <p>13: 9.3 ↓</p> <p>14: *10.6 →</p> <p>15: *10.7 ↓</p> <hr/> <p>Series 48.0</p> <hr/> <p>Total 0.0</p>
<p>20 Shots</p> 	<p>1: 10.2 ↓</p> <p>2: *10.6 ↗</p> <p>3: 9.6 ↑</p> <p>4: *10.3 ↓</p> <p>5: 9.0 ↓</p> <hr/> <p>Series 48.0</p> <hr/> <p>Total 48.0</p>	<p>20 Shots</p> 	<p>6: 10.3 ↓</p> <p>7: 9.2 ↓</p> <p>8: 9.8 →</p> <p>9: 9.5 →</p> <p>10: 10.1 ←</p> <hr/> <p>Series 47.0</p> <hr/> <p>Total 95.0</p>
<p>20 Shots</p> 	<p>11: 9.7 ↓</p> <p>12: 9.4 →</p> <p>13: 9.5 →</p> <p>14: 9.2 ↓</p> <p>15: *10.7 →</p> <hr/> <p>Series 46.0</p> <hr/> <p>Total 141.0</p>	<p>20 Shots</p> 	<p>16: 9.3 ↓</p> <p>17: 10.1 ←</p> <p>18: 9.9 ↖</p> <p>19: 10.1 ↓</p> <p>20: *10.5 ↓</p> <hr/> <p>Series 48.0</p> <hr/> <p>Total 189.0</p>

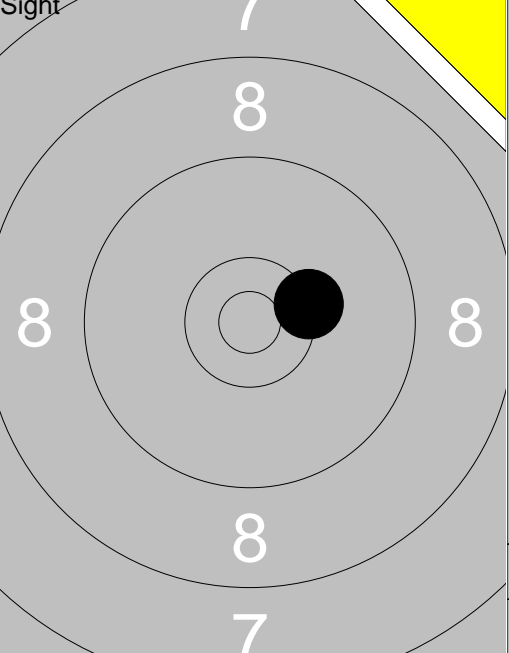
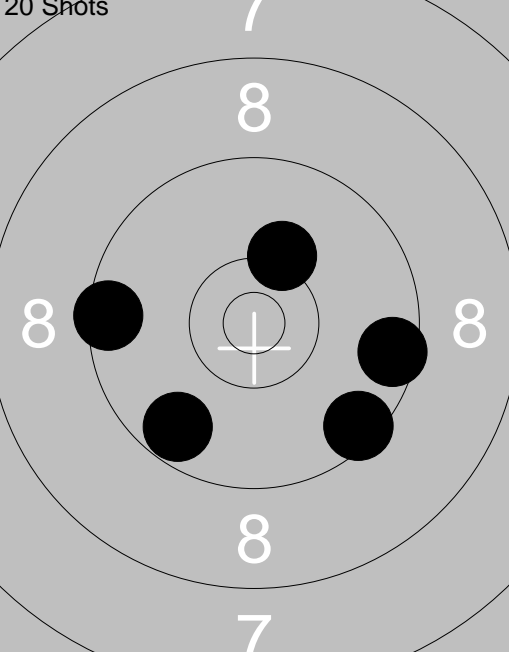
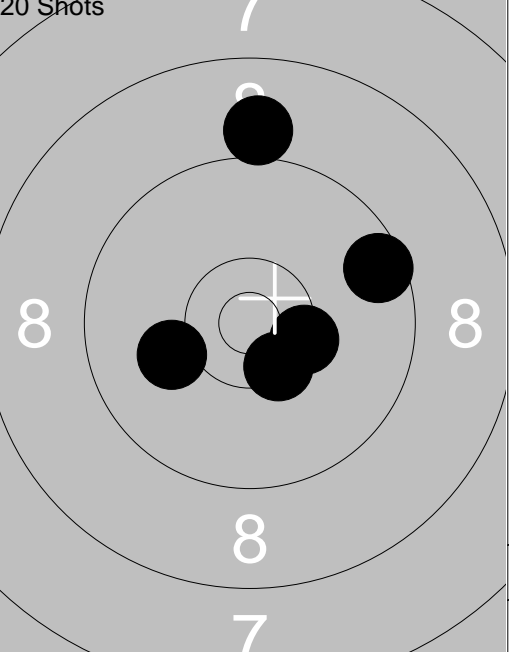
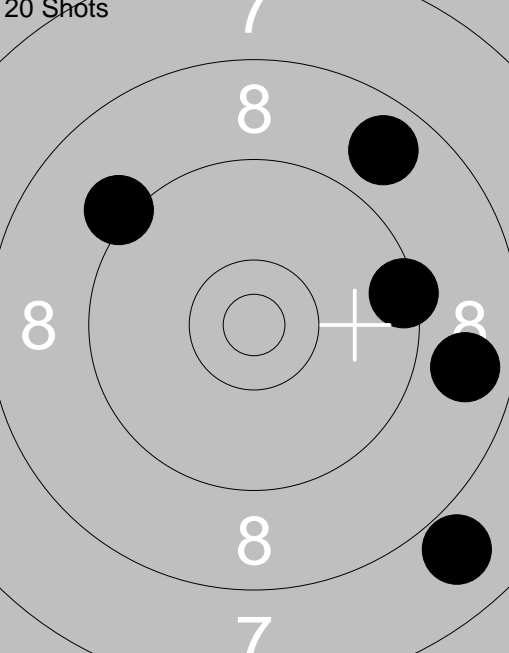
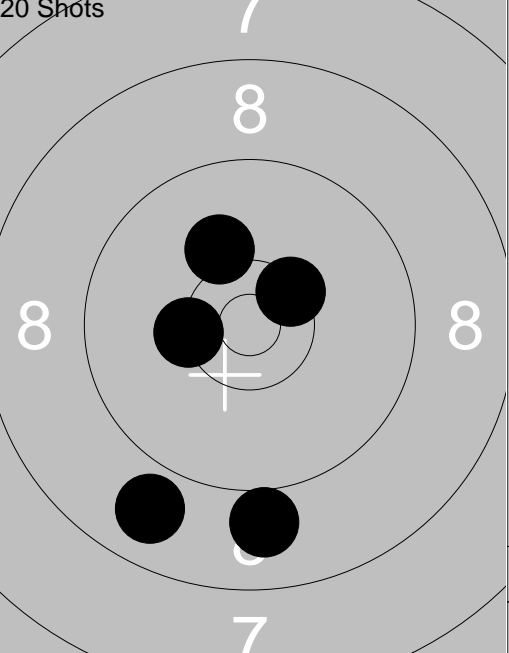
<p>Sight</p> 	<p>1: 6.6 ↓ 2: 9.8 ↙ 3: 8.6 ↓ 4: 9.8 ↖ 5: 8.9 → 6: 9.7 ↑ 7: 9.5 → 8: 10.1 ↗ 9: 10.0 ↗ 10: 10.1 ↖</p> <p>Series 88.0 Total 0.0</p>	<p>Sight</p>  <p>11: *10.3 →</p> <p>Series 10.0 Total 0.0</p>
<p>20 Shots</p> 	<p>1: 9.5 → 2: 10.2 ↑ 3: 9.7 ↓ 4: 9.5 ← 5: 9.5 ↓</p> <p>Series 46.0 Total 46.0</p>	<p>20 Shots</p>  <p>6: *10.4 ↓ 7: *10.4 → 8: 10.1 ↖ 9: 9.0 ↑ 10: 9.6 →</p> <p>Series 48.0 Total 94.0</p>
<p>20 Shots</p> 	<p>11: 9.2 ↖ 12: 8.8 ↗ 13: 7.9 ↓ 14: 9.4 → 15: 8.8 →</p> <p>Series 41.0 Total 135.0</p>	<p>20 Shots</p>  <p>16: 9.0 ↓ 17: *10.3 ↖ 18: 8.9 ↓ 19: *10.4 ↗ 20: 10.1 ↖</p> <p>Series 47.0 Total 182.0</p>

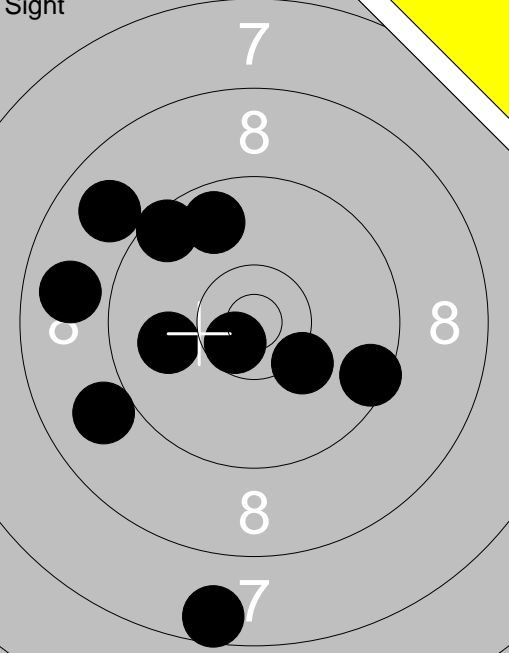
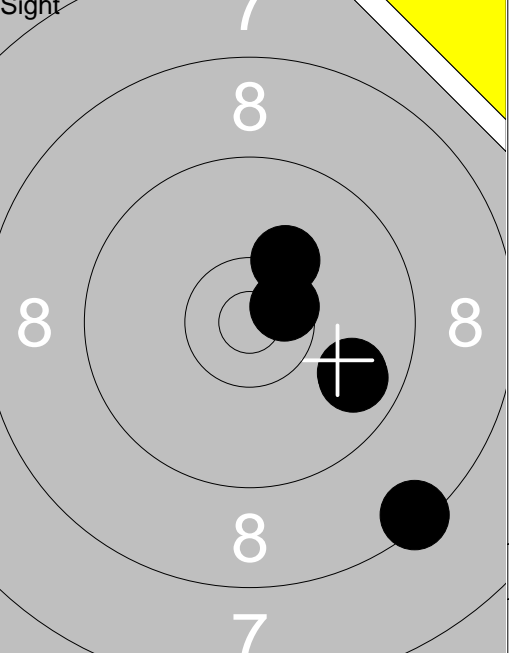
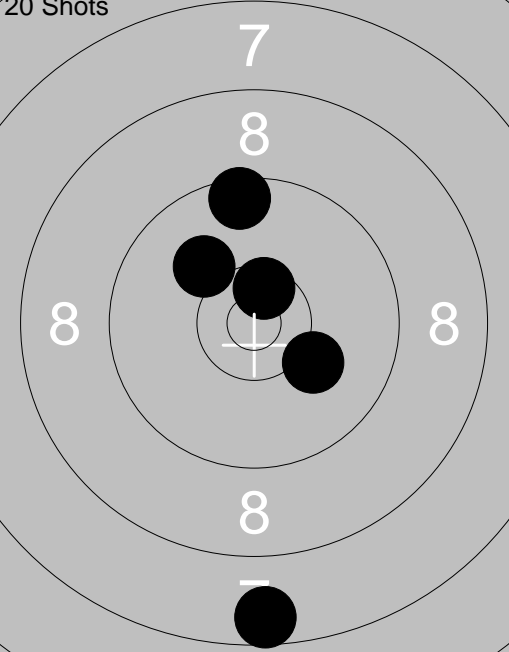
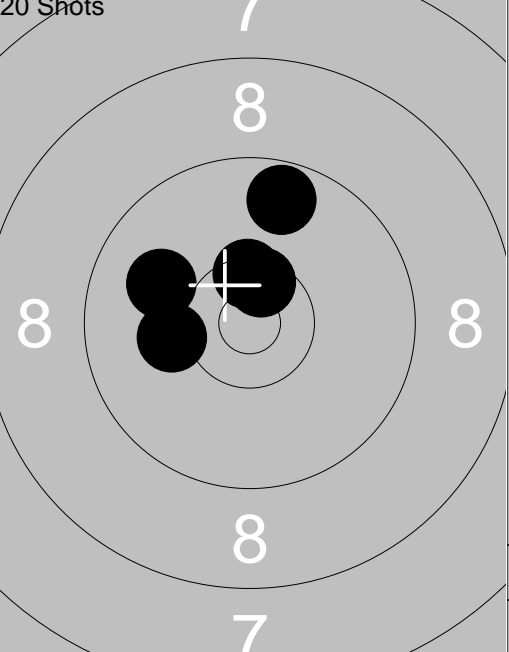
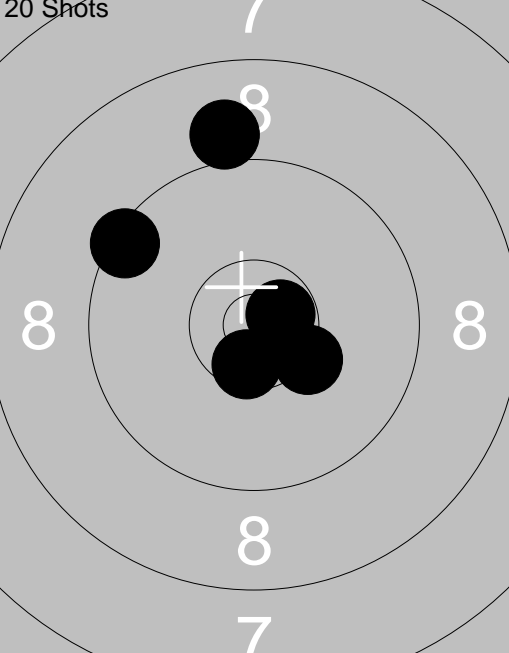
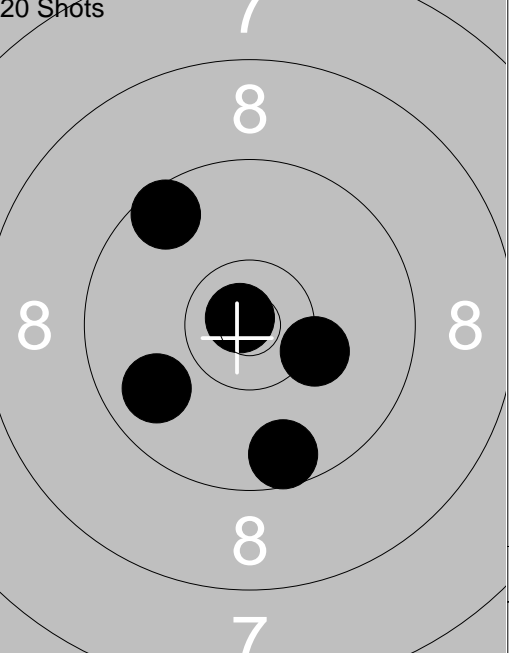
<p>Sight</p> 	<p>1: 8.9 ↖ 2: 10.0 ← 3: 8.8 ← 4: 9.7 ↑ 5: 9.5 ↗ 6: 9.0 ↙ 7: 7.6 ↓ 8: 9.5 → 9: 10.2 ↘ 10: *10.6 ↘</p> <p>Series 89.0 Total 0.0</p>	<p>Sight</p> 	<p>11: 8.4 ↘ 12: 9.8 → 13: 9.8 → 14: 10.2 ↗ 15: *10.6 →</p> <p>Series 46.0 Total 0.0</p>
<p>20 Shots</p> 	<p>1: 7.6 ↓ 2: *10.5 ↗ 3: 10.1 ↘ 4: 9.5 ↑ 5: 10.1 ↖</p> <p>Series 46.0 Total 46.0</p>	<p>20 Shots</p> 	<p>6: 10.2 ← 7: 10.0 ↙ 8: *10.5 ↗ 9: 9.7 ↑ 10: *10.5 ↗</p> <p>Series 49.0 Total 95.0</p>
<p>20 Shots</p> 	<p>11: 9.4 ↖ 12: 9.0 ↑ 13: *10.5 ↘ 14: *10.7 → 15: *10.3 ↘</p> <p>Series 48.0 Total 143.0</p>	<p>20 Shots</p> 	<p>16: *10.8 ↘ 17: 9.8 ↙ 18: 9.6 ↓ 19: 9.6 ↗ 20: 10.3 →</p> <p>Series 47.0 Total 190.0</p>

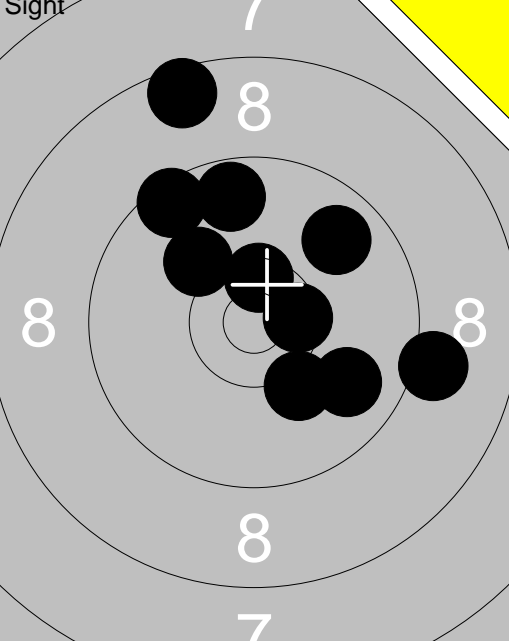
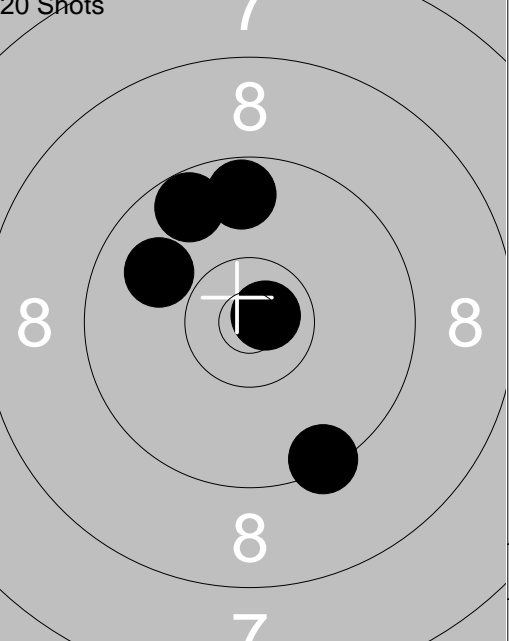
<p>Sight</p> 	<p>20 Shots</p> 	<table style="width:100%; border-collapse: collapse;"> <tr><td>1: 9.1 →</td><td>1: 9.4 ↓</td></tr> <tr><td>2: 9.8 →</td><td>2: 9.9 ↖</td></tr> <tr><td>3: 9.8 ↗</td><td>3: 9.7 ↑</td></tr> <tr><td>4: 8.6 ↑</td><td>4: 9.7 ↖</td></tr> <tr><td>5: *10.5↑</td><td>5: *10.8↗</td></tr> <tr><td>6: *10.5→</td><td></td></tr> <tr><td>7: 9.5 ↖</td><td></td></tr> <tr><td>8: 10.2 ↓</td><td></td></tr> <tr><td>9: 9.7 ↑</td><td></td></tr> <tr><td>10: 10.1↖</td><td></td></tr> <tr><td colspan="2"><hr/></td></tr> <tr><td>Series 93.0</td><td>Series 46.0</td></tr> <tr><td>Total 0.0</td><td>Total 46.0</td></tr> </table>	1: 9.1 →	1: 9.4 ↓	2: 9.8 →	2: 9.9 ↖	3: 9.8 ↗	3: 9.7 ↑	4: 8.6 ↑	4: 9.7 ↖	5: *10.5↑	5: *10.8↗	6: *10.5→		7: 9.5 ↖		8: 10.2 ↓		9: 9.7 ↑		10: 10.1↖		<hr/>		Series 93.0	Series 46.0	Total 0.0	Total 46.0
1: 9.1 →	1: 9.4 ↓																											
2: 9.8 →	2: 9.9 ↖																											
3: 9.8 ↗	3: 9.7 ↑																											
4: 8.6 ↑	4: 9.7 ↖																											
5: *10.5↑	5: *10.8↗																											
6: *10.5→																												
7: 9.5 ↖																												
8: 10.2 ↓																												
9: 9.7 ↑																												
10: 10.1↖																												
<hr/>																												
Series 93.0	Series 46.0																											
Total 0.0	Total 46.0																											

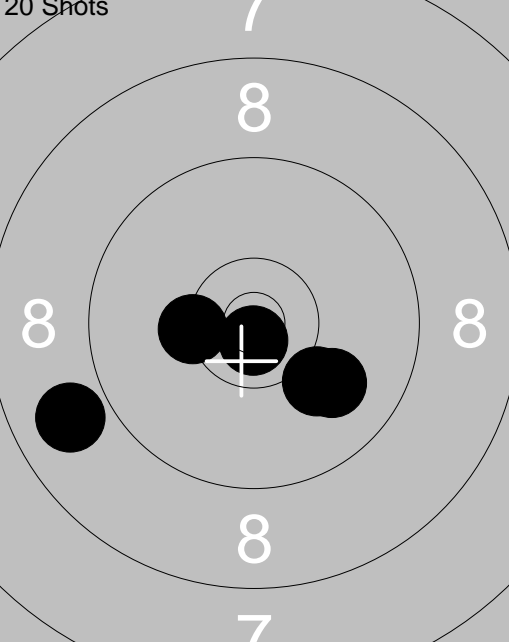
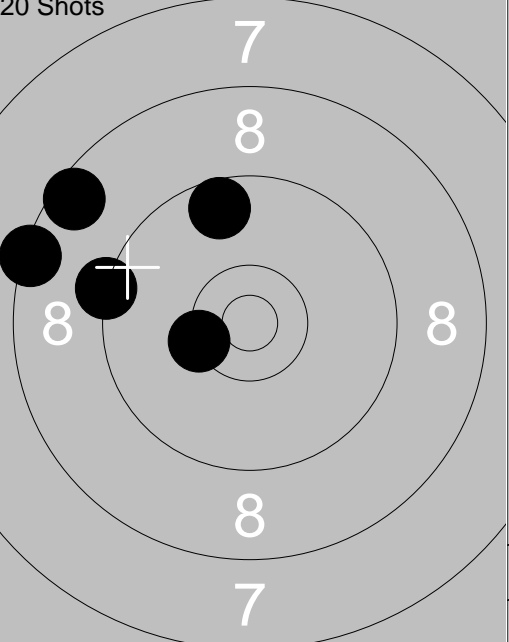
<p>20 Shots</p> 	<p>20 Shots</p> 	<table style="width:100%; border-collapse: collapse;"> <tr><td>6: 10.1 ↓</td><td>11: *10.3↖</td></tr> <tr><td>7: 8.9 ↖</td><td>12: 9.3 ↖</td></tr> <tr><td>8: *10.3↖</td><td>13: 8.5 ↖</td></tr> <tr><td>9: *10.8↓</td><td>14: 8.4 ↖</td></tr> <tr><td>10: 10.0 ↓</td><td>15: 9.6 ↑</td></tr> <tr><td colspan="2"><hr/></td></tr> <tr><td>Series 48.0</td><td>Series 44.0</td></tr> <tr><td>Total 94.0</td><td>Total 138.0</td></tr> </table>	6: 10.1 ↓	11: *10.3↖	7: 8.9 ↖	12: 9.3 ↖	8: *10.3↖	13: 8.5 ↖	9: *10.8↓	14: 8.4 ↖	10: 10.0 ↓	15: 9.6 ↑	<hr/>		Series 48.0	Series 44.0	Total 94.0	Total 138.0
6: 10.1 ↓	11: *10.3↖																	
7: 8.9 ↖	12: 9.3 ↖																	
8: *10.3↖	13: 8.5 ↖																	
9: *10.8↓	14: 8.4 ↖																	
10: 10.0 ↓	15: 9.6 ↑																	
<hr/>																		
Series 48.0	Series 44.0																	
Total 94.0	Total 138.0																	

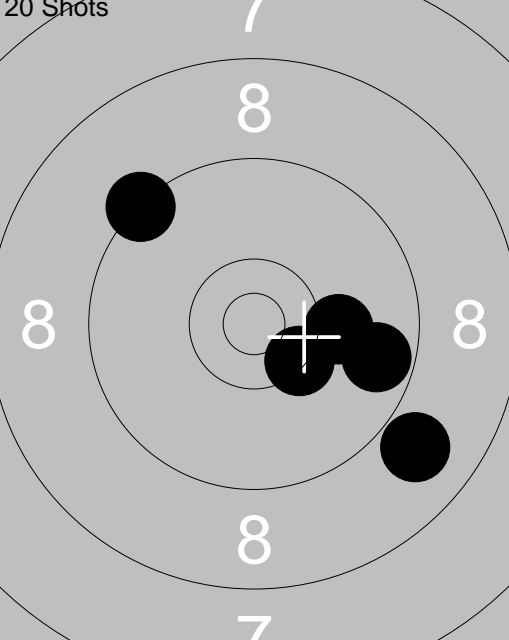
<p>20 Shots</p> 	<table style="width:100%; border-collapse: collapse;"> <tr><td>16: *10.4↓</td></tr> <tr><td>17: 8.9 ↓</td></tr> <tr><td>18: 10.1→</td></tr> <tr><td>19: 9.3 ↗</td></tr> <tr><td>20: 9.7 →</td></tr> <tr><td colspan="2"><hr/></td></tr> <tr><td>Series 46.0</td></tr> <tr><td>Total 184.0</td></tr> </table>	16: *10.4↓	17: 8.9 ↓	18: 10.1→	19: 9.3 ↗	20: 9.7 →	<hr/>		Series 46.0	Total 184.0
16: *10.4↓										
17: 8.9 ↓										
18: 10.1→										
19: 9.3 ↗										
20: 9.7 →										
<hr/>										
Series 46.0										
Total 184.0										

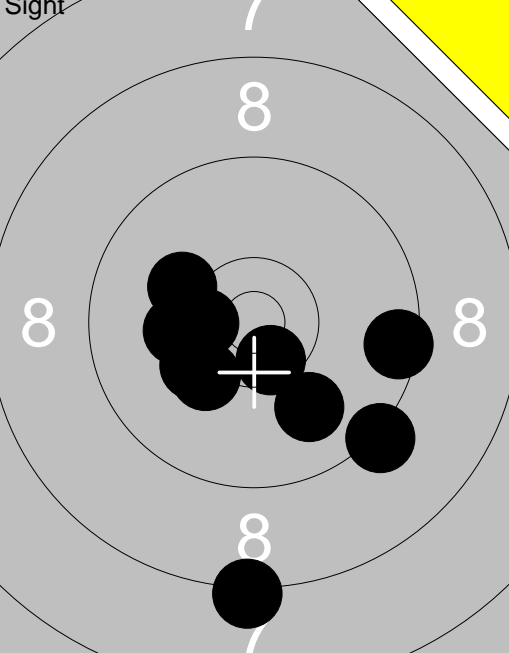
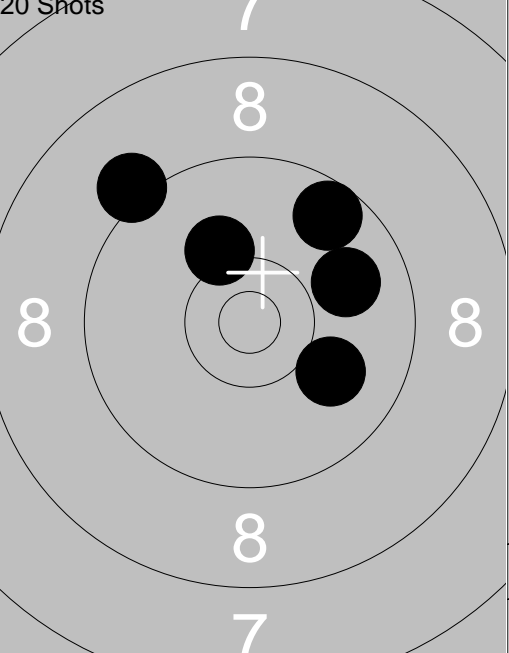
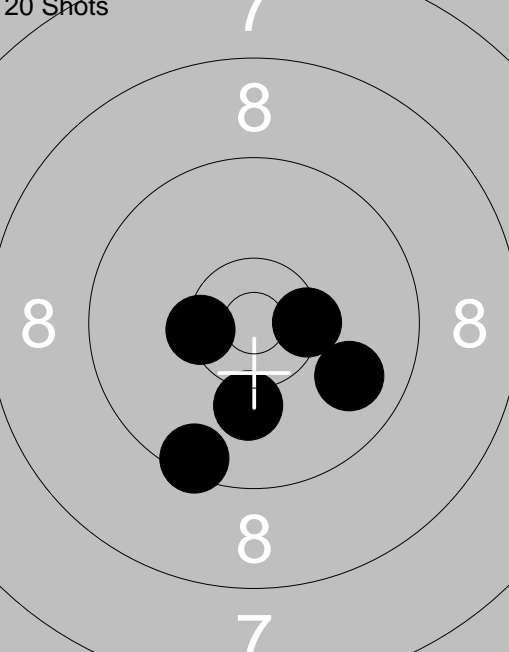
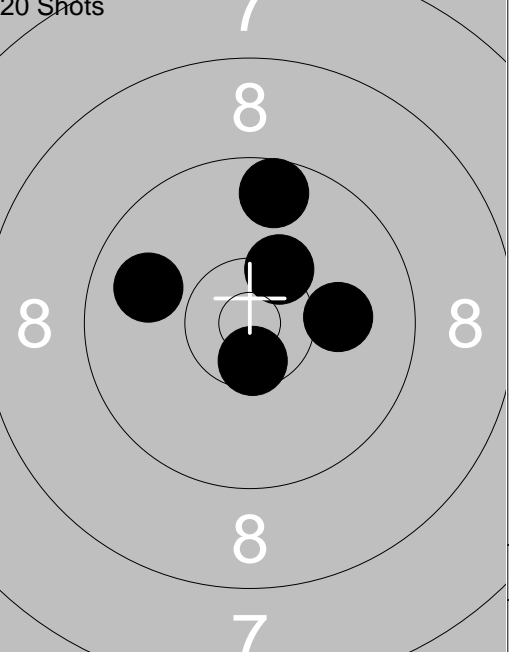
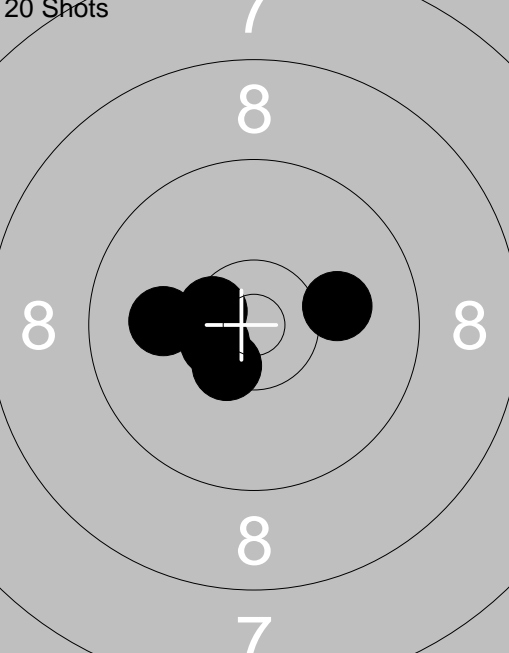
<p>Sight</p> 	<p>1: 9.9 ↘ 2: 8.2 ↓ 3: *10.5 ↘ 4: 10.2 ↙ 5: 9.5 → 6: 10.1 ↖ 7: 10.2 ↘ 8: *10.5 ← 9: 9.2 ↘ 10: 10.2 ←</p> <p>Series 95.0 Total 0.0</p>	<p>20 Shots</p> 		<p>1: 9.9 → 2: 9.2 ↖ 3: 10.2 ↗ 4: 9.6 ↗ 5: 10.0 ↘</p> <p>Series 47.0 Total 47.0</p>
<p>20 Shots</p> 	<p>6: 10.1 ↓ 7: 9.5 ↓ 8: 9.9 → 9: *10.4 ← 10: *10.4 →</p> <p>Series 48.0 Total 95.0</p>	<p>20 Shots</p> 		<p>11: 10.1 → 12: *10.3 ↗ 13: *10.6 ↓ 14: 9.9 ← 15: 9.6 ↑</p> <p>Series 48.0 Total 143.0</p>
<p>20 Shots</p> 	<p>16: 10.0 ← 17: *10.5 ↘ 18: 10.1 → 19: *10.5 ← 20: *10.5 ↘</p> <p>Series 50.0 Total 193.0</p>			

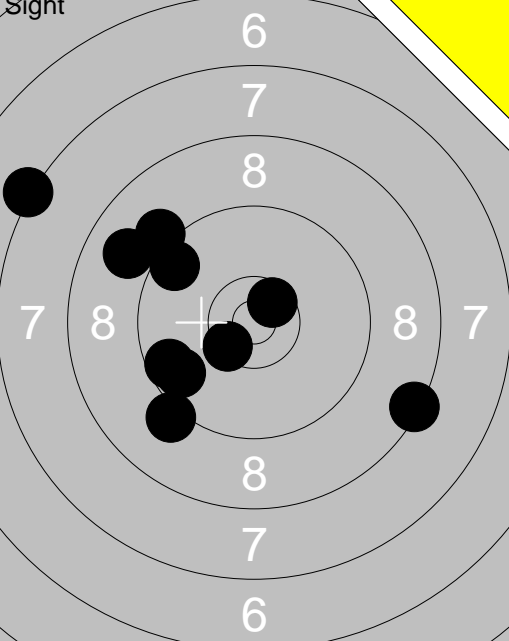
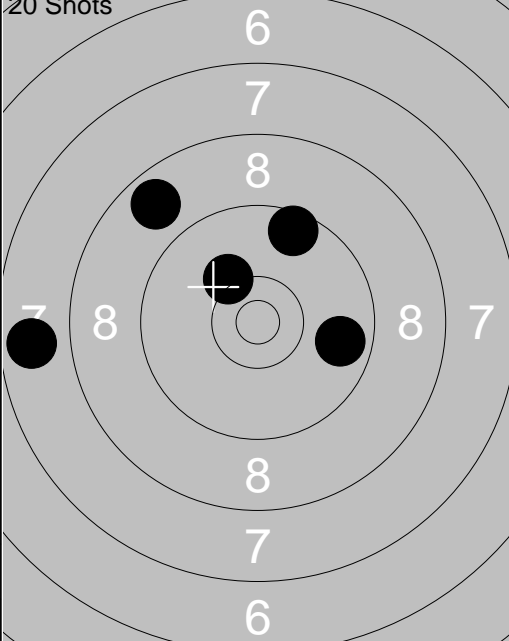
 <p>Sight</p>	<p>1: 8.9 ↙ 2: 8.4 ➔ 3: 7.2 ↙ 4: 9.1 ↘ 5: 9.6 ↙ 6: *10.6 ↗ 7: 9.7 ↙ 8: 9.1 ↗ 9: 9.6 ↙ 10: *10.4 ↘</p>	 <p>20 Shots</p>	<p>1: 9.8 ➔ 2: 7.8 ← 3: 9.6 ↗ 4: 8.8 ↙ 5: 10.2 ↗</p>
<p>Series 88.0</p>		<p>Series 43.0</p>	
<p>Total 0.0</p>		<p>Total 43.0</p>	

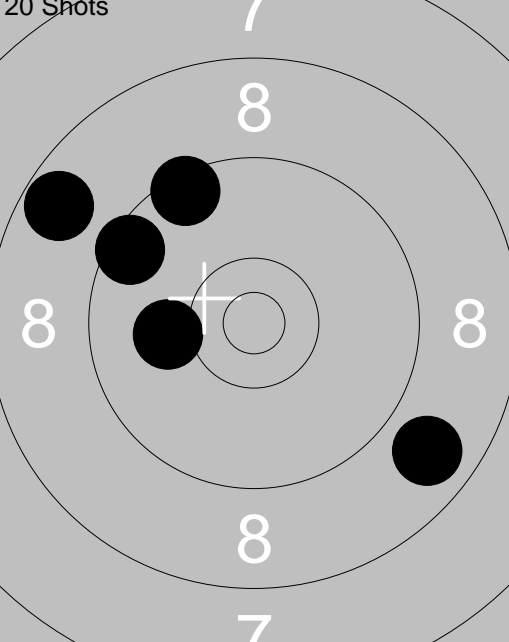
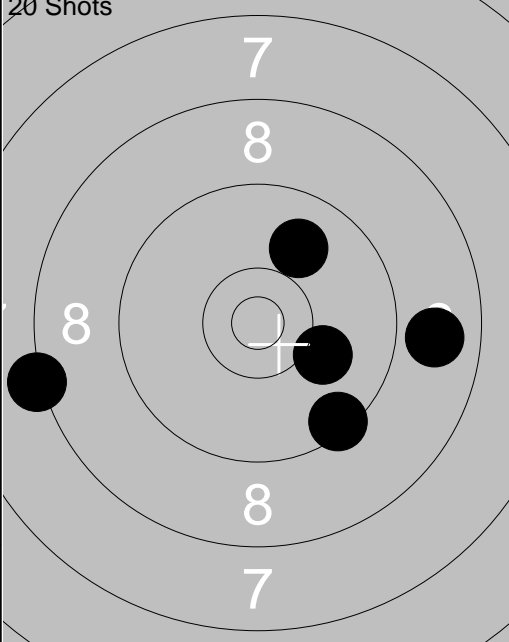
 <p>20 Shots</p>	<p>6: 8.8 ➔ 7: 8.7 ↙ 8: 9.5 ↗ 9: 10.1 ← 10: 9.5 ↙</p>	 <p>20 Shots</p>	<p>11: 8.8 ➔ 12: 10.1 ➔ 13: 9.4 ↘ 14: 8.2 ← 15: 9.9 ↗</p>
<p>Series 44.0</p>		<p>Series 44.0</p>	
<p>Total 87.0</p>		<p>Total 131.0</p>	

 <p>20 Shots</p>	<p>16: 8.2 ↙ 17: 9.1 ↙ 18: 10.1 ← 19: 9.2 ↗ 20: 6.4 ↗</p>		
<p>Series 42.0</p>			
<p>Total 173.0</p>			

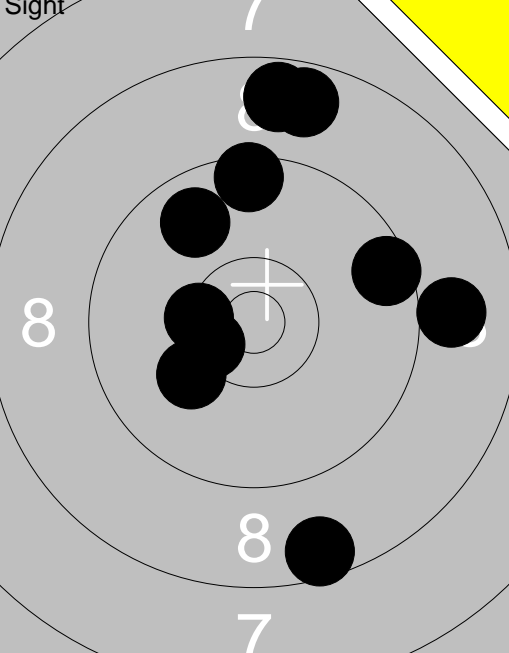
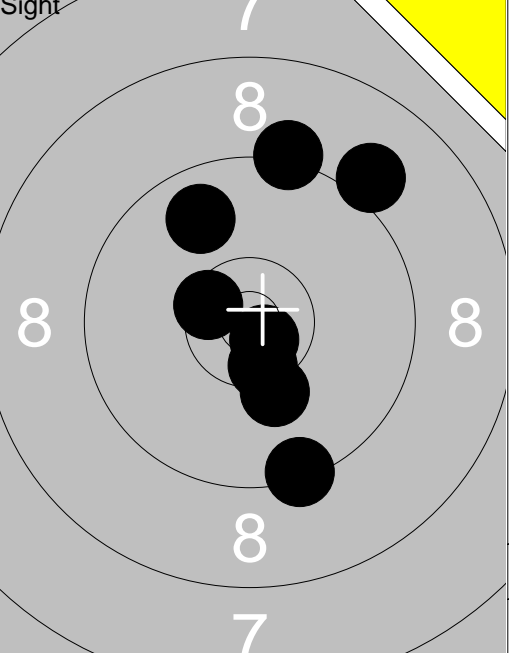
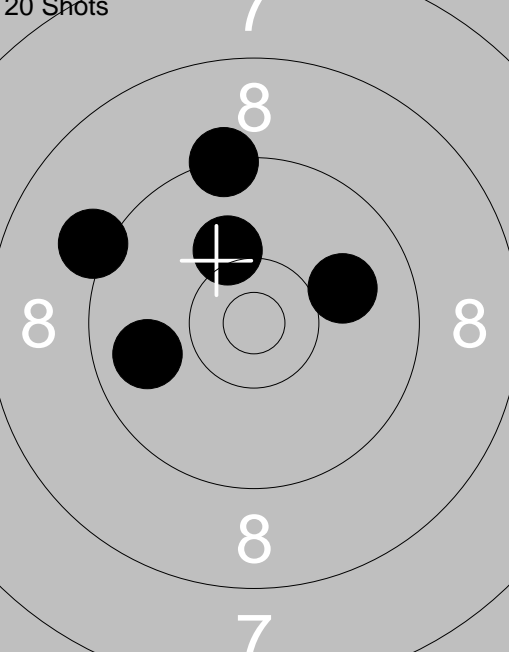
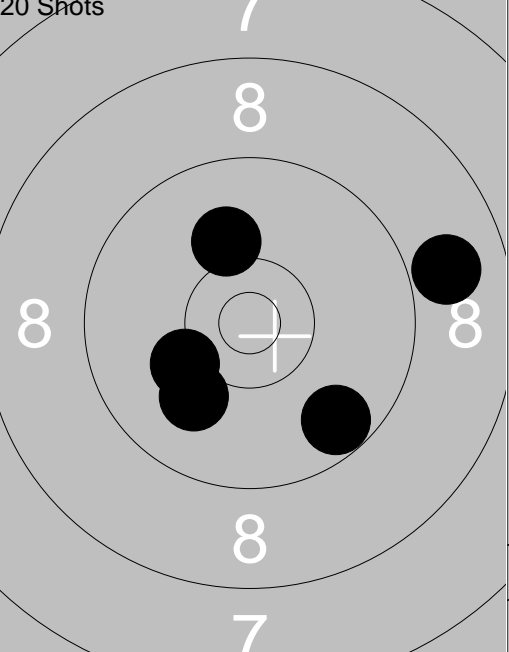
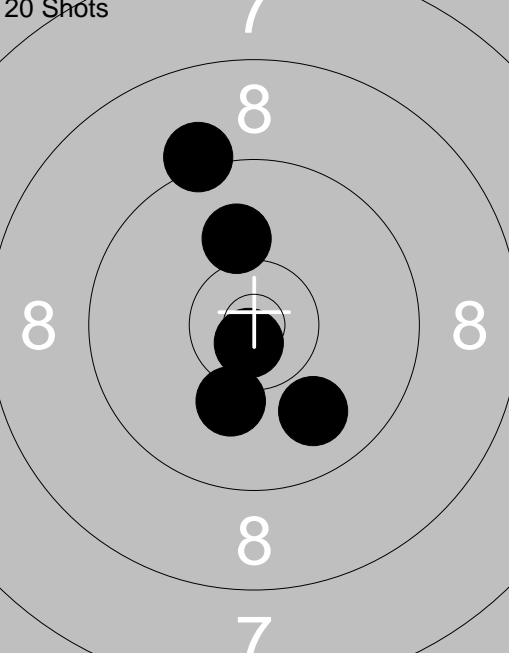
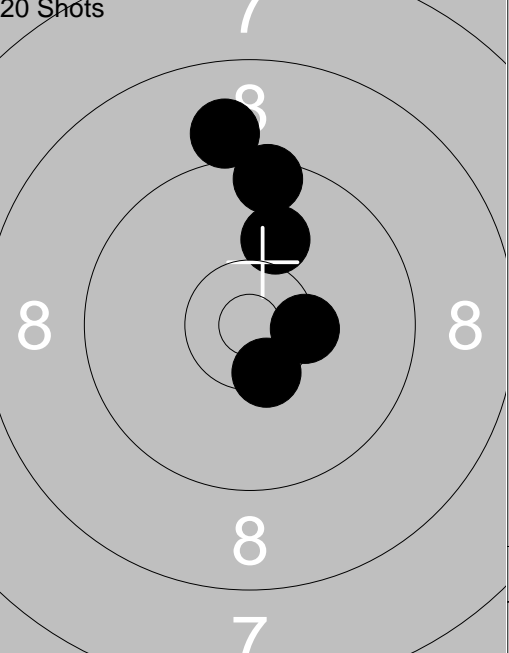
<p>Sight</p>  <p style="text-align: center;">8</p>	<p>1: 10.1 ↙ 2: 8.7 ↑ 3: 8.7 ↑ 4: *10.4 ↙ 5: 9.8 ↖ 6: 8.6 ↓ 7: 9.5 ↑ 8: *10.5 ↙ 9: 9.5 → 10: 9.0 →</p> <p>Series 90.0 Total 0.0</p>	<p>Sight</p>  <p style="text-align: center;">8</p>	<p>11: 9.1 ↗ 12: 9.2 ↑ 13: 10.2 ↓ 14: 9.8 ↖ 15: *10.7 ↘ 16: 9.4 ↓ 17: *10.5 ↓ 18: *10.5 ↙</p> <p>Series 76.0 Total 0.0</p>
<p>20 Shots</p>  <p style="text-align: center;">8</p>	<p>1: 10.0 → 2: 9.8 ← 3: 9.2 ↖ 4: 10.2 ↑ 5: 9.3 ↑</p> <p>Series 47.0 Total 47.0</p>	<p>20 Shots</p>  <p style="text-align: center;">8</p>	<p>6: 8.9 → 7: 9.7 ↓ 8: 10.1 ↖ 9: 10.0 ↘ 10: 10.2 ↙</p> <p>Series 47.0 Total 94.0</p>
<p>20 Shots</p>  <p style="text-align: center;">8</p>	<p>11: *10.8 ↓ 12: 9.2 ↑ 13: 9.9 ↓ 14: 10.1 ↑ 15: 10.2 ↓</p> <p>Series 48.0 Total 142.0</p>	<p>20 Shots</p>  <p style="text-align: center;">8</p>	<p>16: *10.4 ↓ 17: 10.1 ↖ 18: *10.4 → 19: 9.0 ↑ 20: 9.5 ↑</p> <p>Series 48.0 Total 190.0</p>