

| | | | |
|-------------------|------------------|-------------------------|--|
| Relay 2 | Lane 1 | Leif Sigfridsson | |
|-------------------|------------------|-------------------------|--|

| | | |
|------|------|---|
| 300m | Umeå | Ä |
|------|------|---|

| | | |
|------------|-----------------------------|-----------------|
| 2013-07-27 | Postens Riksmästerskap 2013 | Ramselefors SKF |
|------------|-----------------------------|-----------------|

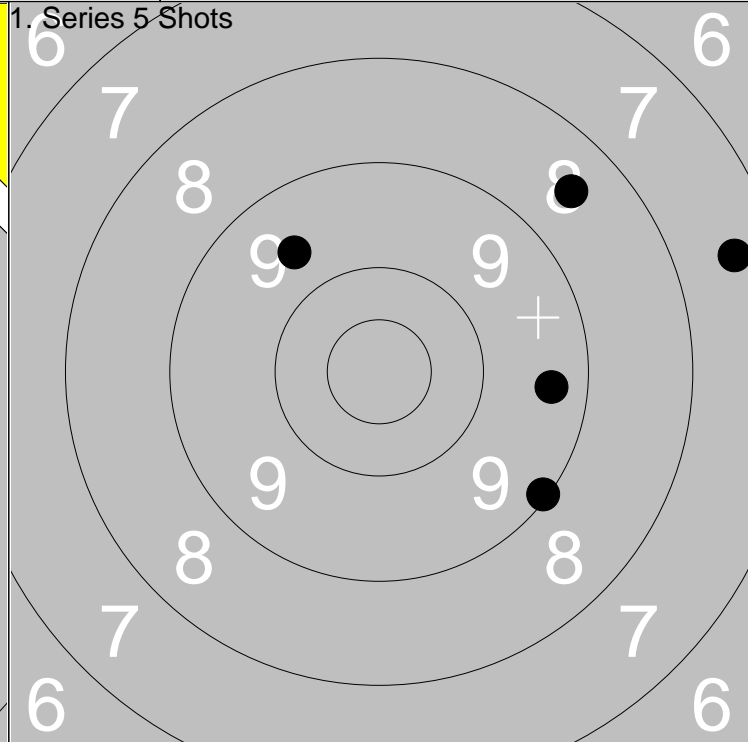
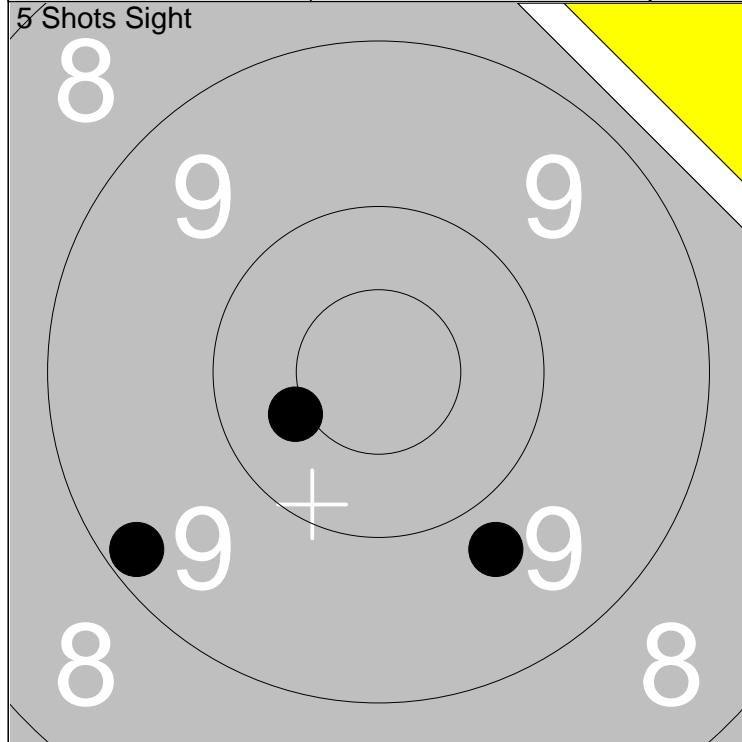

| |
|--------------------|
| 1: 9.2 ↙ |
| 2: *10.4 ↙ |
| 3: 9.7 ↘ |
| Series 28.0 |
| Total 0.0 |

| |
|--------------------|
| 1: 7.5 → |
| 2: 9.1 ↘ |
| 3: 8.5 ↗ |
| 4: 9.6 ↖ |
| 5: 9.4 → |
| Series 42.0 |
| Total 42.0 |

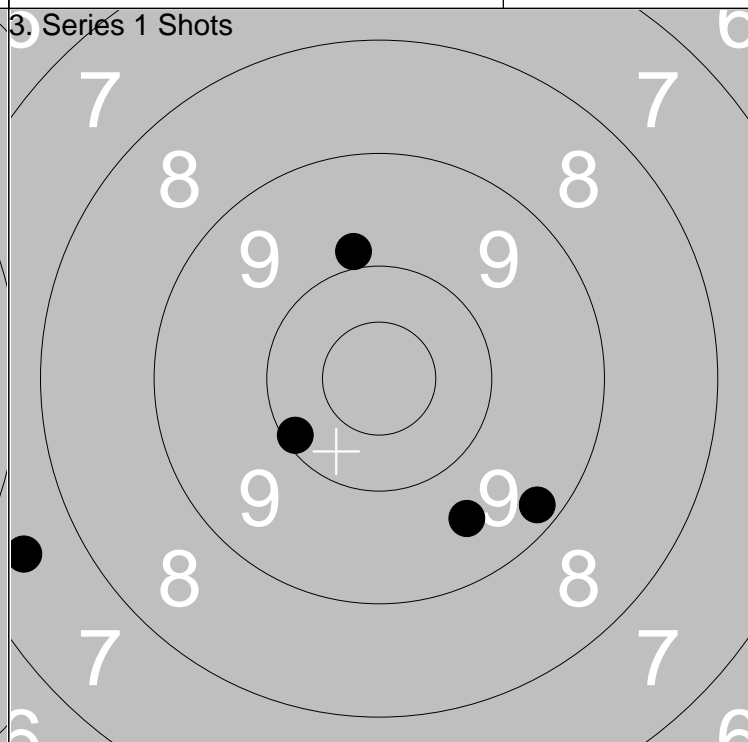
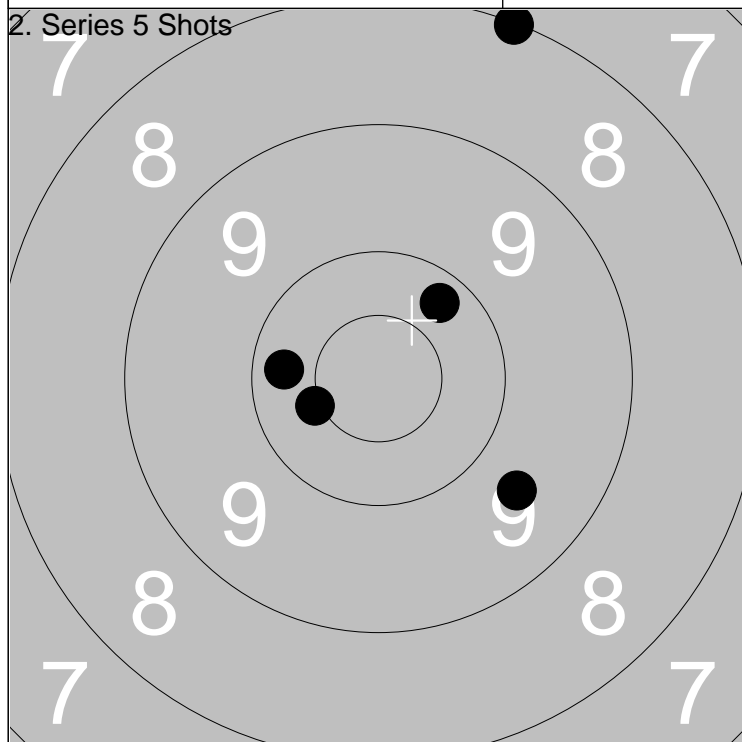

| |
|--------------------|
| 1: 8.0 ↗ |
| 2: 10.2 ↗ |
| 3: *10.4 ↙ |
| 4: 9.6 ↘ |
| 5: 10.3 ← |
| Series 47.0 |
| Total 89.0 |

| |
|--------------------|
| 1: 10.1 ↙ |
| 2: 9.9 ↗ |
| 3: 9.2 ↘ |
| 4: 7.5 ← |
| 5: 9.6 ↘ |
| Series 44.0 |
| Total 133.0 |

| | | | |
|-------------------|------------------|---------------------|--|
| Relay 2 | Lane 2 | Bo Andersson | |
|-------------------|------------------|---------------------|--|

| | | |
|------|--------|---|
| 300m | Nässjö | Ä |
|------|--------|---|

| | | |
|------------|-----------------------------|-----------------|
| 2013-07-27 | Postens Riksmästerskap 2013 | Ramselefors SKF |
|------------|-----------------------------|-----------------|

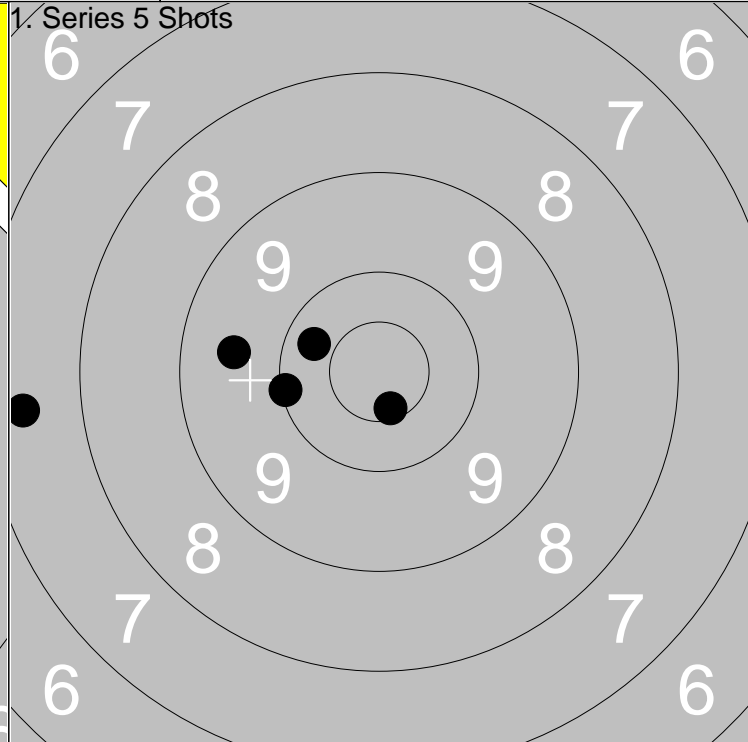
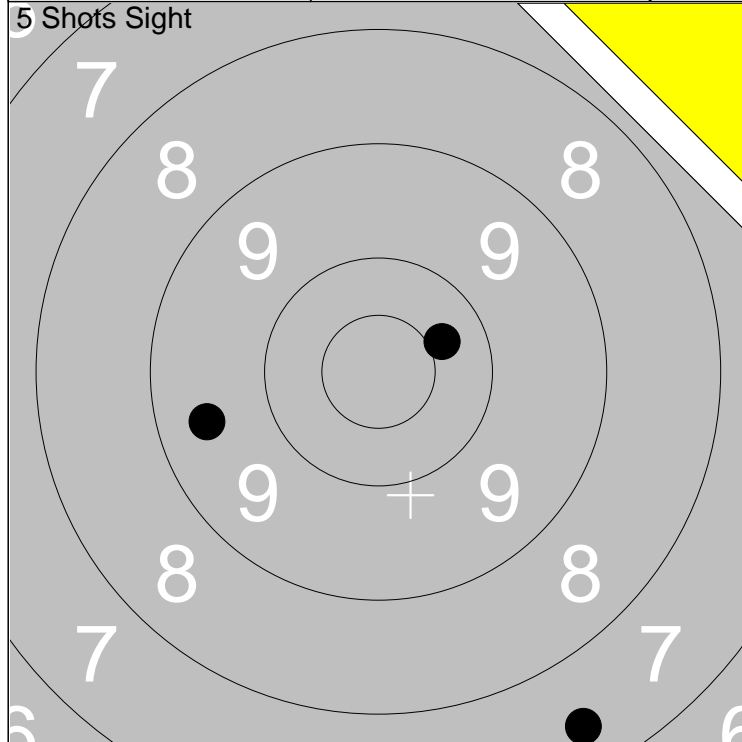

| | | |
|-----------|--------|------|
| 1: 9.5 ← | Series | 26.0 |
| 2: 10.4 → | | |
| 3: 7.4 ↓ | | |
| Total | | 0.0 |

| | | |
|------------|--------|------|
| 1: 7.4 ← | Series | 46.0 |
| 2: *10.6 ↓ | | |
| 3: 10.3 ← | | |
| 4: 10.1 ← | | |
| 5: 9.6 ← | | |
| Total | | 46.0 |

| | | |
|------------|--------|------|
| 1: 7.4 ← | Series | 46.0 |
| 2: *10.6 ↓ | | |
| 3: 10.3 ← | | |
| 4: 10.1 ← | | |
| 5: 9.6 ← | | |
| Total | | 46.0 |

| | | |
|------------|--------|------|
| 1: 7.4 ← | Series | 46.0 |
| 2: *10.6 ↓ | | |
| 3: 10.3 ← | | |
| 4: 10.1 ← | | |
| 5: 9.6 ← | | |
| Total | | 46.0 |

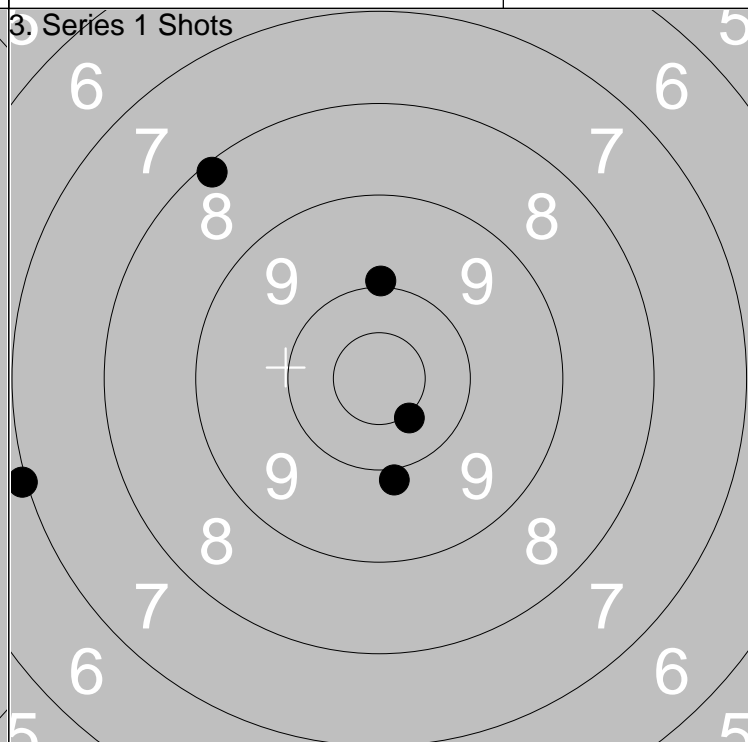
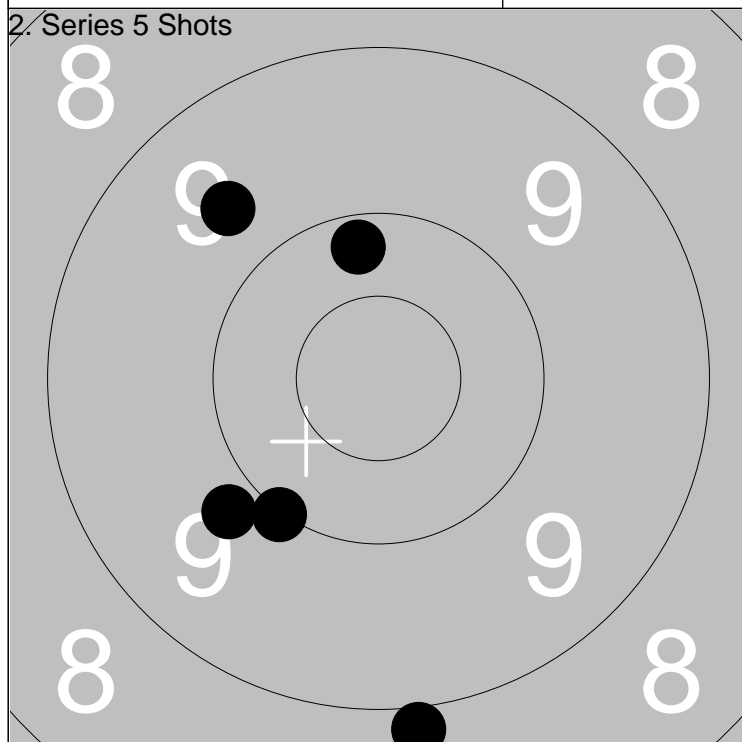

| | | |
|-----------|--------|------|
| 1: 10.2 ↑ | Series | 46.0 |
| 2: 9.7 ↖ | | |
| 3: 9.8 ← | | |
| 4: 8.9 ↓ | | |
| 5: 10.0 ↙ | | |
| Total | | 92.0 |

| | | |
|------------|--------|-------|
| 1: *10.4 ↓ | Series | 44.0 |
| 2: 9.9 ↓ | | |
| 3: 7.0 ← | | |
| 4: 10.0 ↑ | | |
| 5: 8.1 ↖ | | |
| Total | | 136.0 |

| | | |
|------------|--------|-------|
| 1: *10.4 ↓ | Series | 44.0 |
| 2: 9.9 ↓ | | |
| 3: 7.0 ← | | |
| 4: 10.0 ↑ | | |
| 5: 8.1 ↖ | | |
| Total | | 136.0 |

| | | |
|------------|--------|-------|
| 1: *10.4 ↓ | Series | 44.0 |
| 2: 9.9 ↓ | | |
| 3: 7.0 ← | | |
| 4: 10.0 ↑ | | |
| 5: 8.1 ↖ | | |
| Total | | 136.0 |

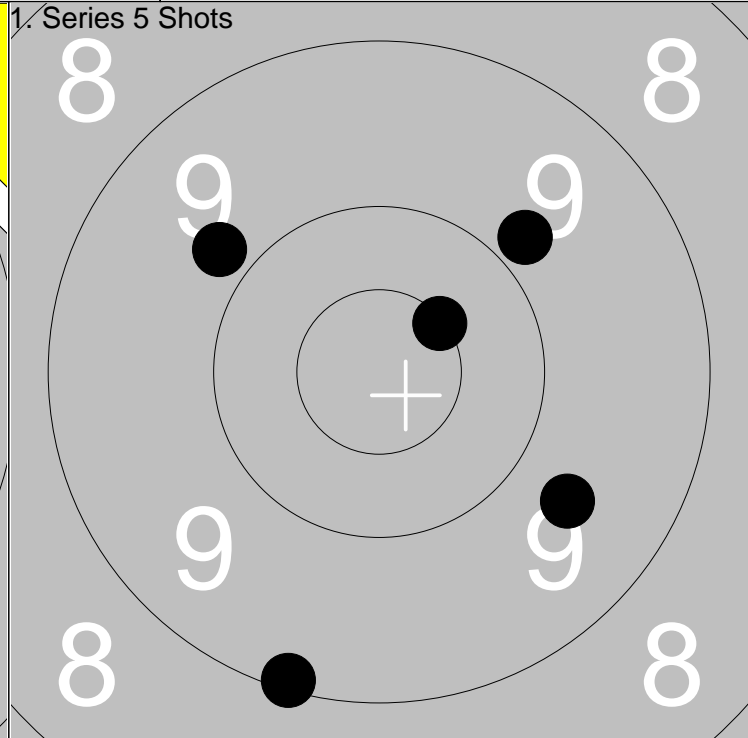
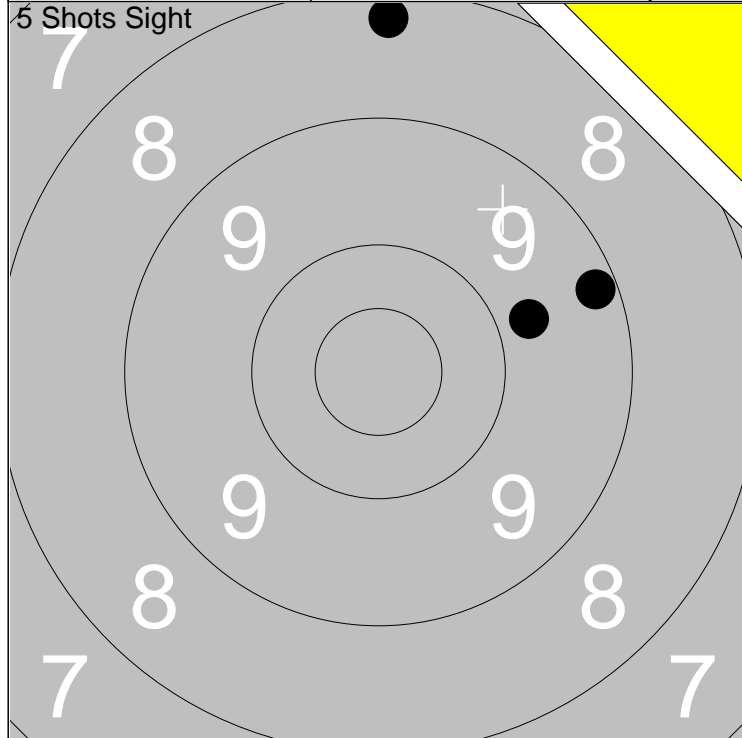

| | | |
|----------|--------|------|
| 1: 8.2 ↑ | Series | 26.0 |
| 2: 9.8 → | | |
| 3: 9.2 → | | |
| Total | | 0.0 |

| | | |
|------------|--------|------|
| 1: 9.7 ↘ | Series | 46.0 |
| 2: 9.8 ↗ | | |
| 3: *10.5 ↗ | | |
| 4: 9.8 ↖ | | |
| 5: 9.1 ↓ | | |
| Total | | 46.0 |

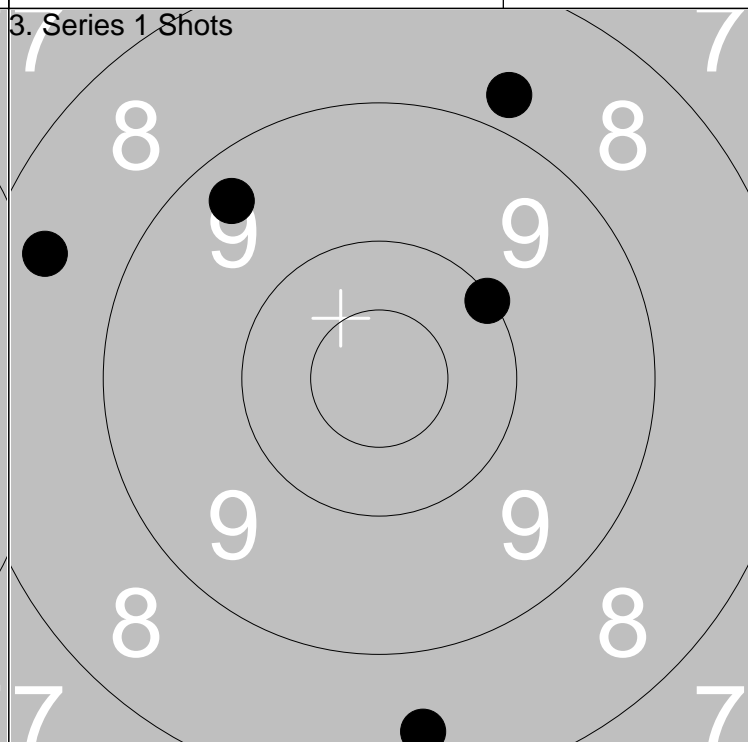
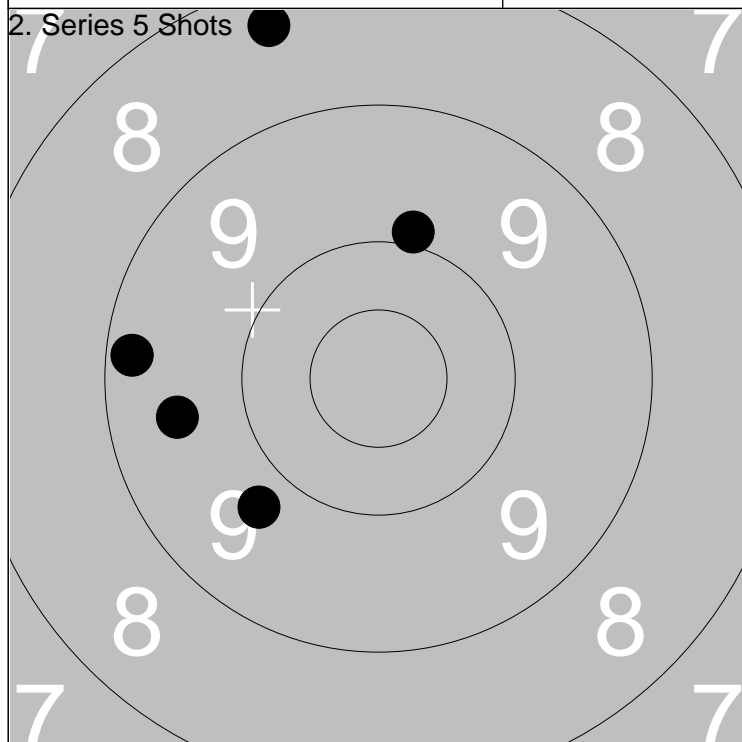

| | | |
|----------|--------|------|
| 1: 8.3 ↑ | Series | 44.0 |
| 2: 9.9 ↑ | | |
| 3: 9.2 ← | | |
| 4: 9.7 ↘ | | |
| 5: 9.5 ← | | |
| Total | | 90.0 |

| | | |
|-----------|--------|-------|
| 1: 8.8 ↑ | Series | 43.0 |
| 2: 9.4 ↖ | | |
| 3: 10.1 ↗ | | |
| 4: 8.4 ↖ | | |
| 5: 8.4 ↓ | | |
| Total | | 133.0 |

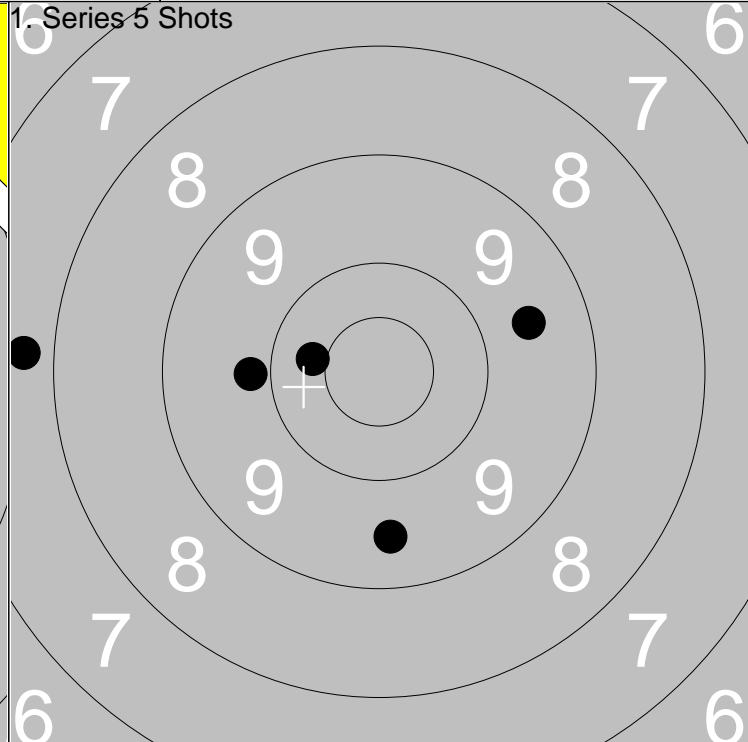
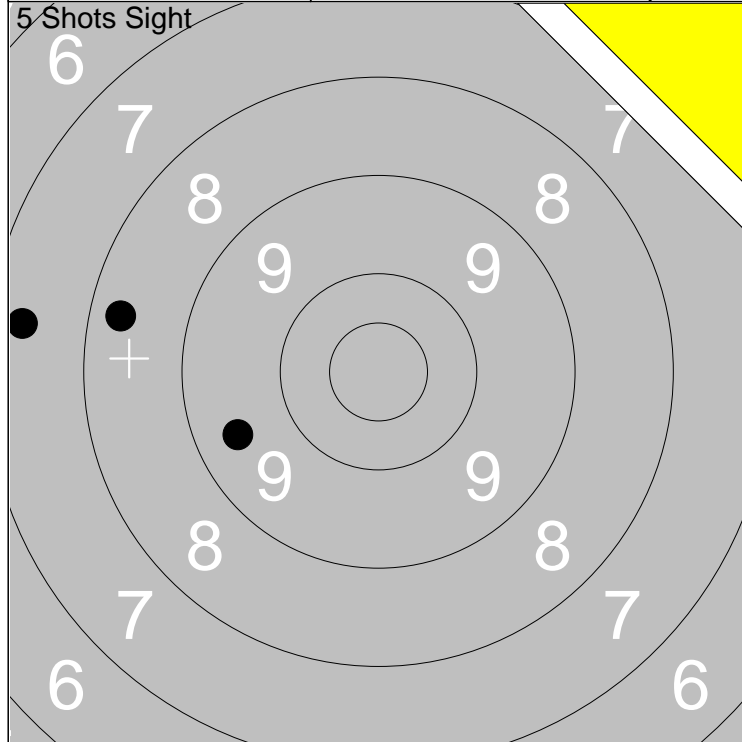

| | |
|--------------|----------------|
| 1: 7.4 ← | Series 24.0 |
| 2: 9.5 ← | |
| 3: 8.3 ← | |
| Total 0.0 | |

| | |
|---------------|----------------|
| 1: 10.4 ← | Series 44.0 |
| 2: 9.5 ↓ | |
| 3: 9.6 → | |
| 4: 7.8 ← | |
| 5: 9.8 ← | |
| Total 44.0 | |

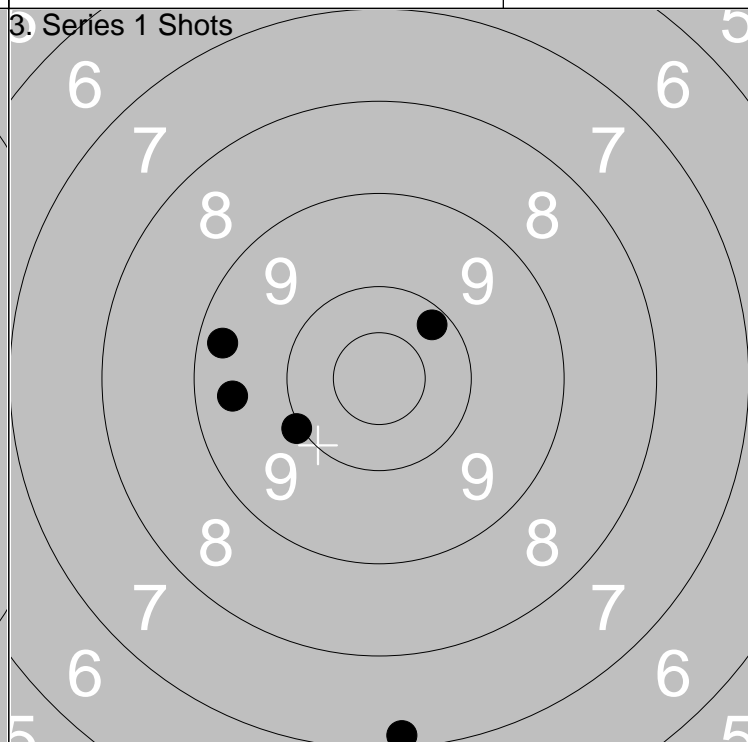
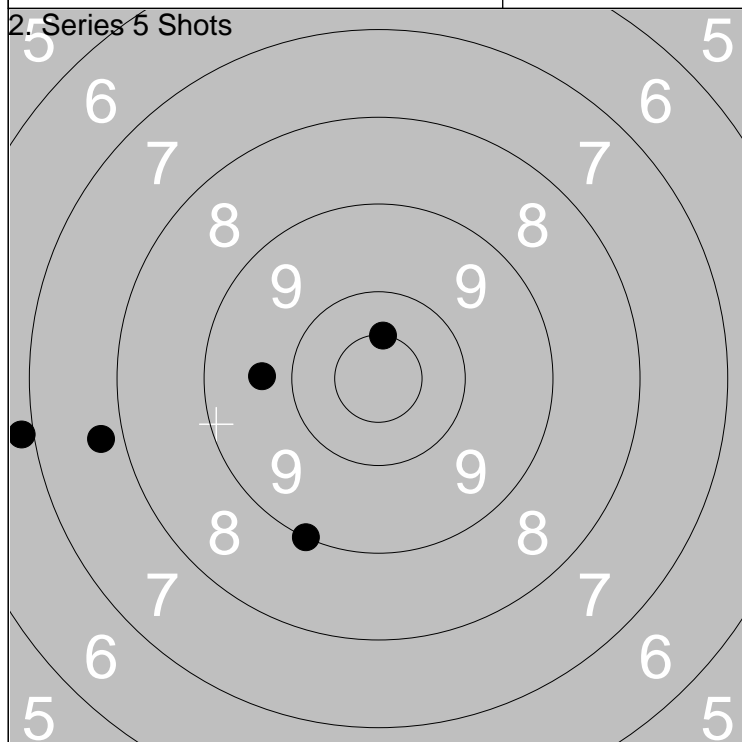

| | |
|---------------|----------------|
| 1: 7.8 ← | Series 41.0 |
| 2: *10.5 ↑ | |
| 3: 9.7 ← | |
| 4: 9.0 ↓ | |
| 5: 6.9 ← | |
| Total 85.0 | |

| | |
|----------------|----------------|
| 1: 9.3 ← | Series 45.0 |
| 2: 10.2 ↗ | |
| 3: 10.0 ← | |
| 4: 9.4 ← | |
| 5: 7.2 ↓ | |
| Total 130.0 | |

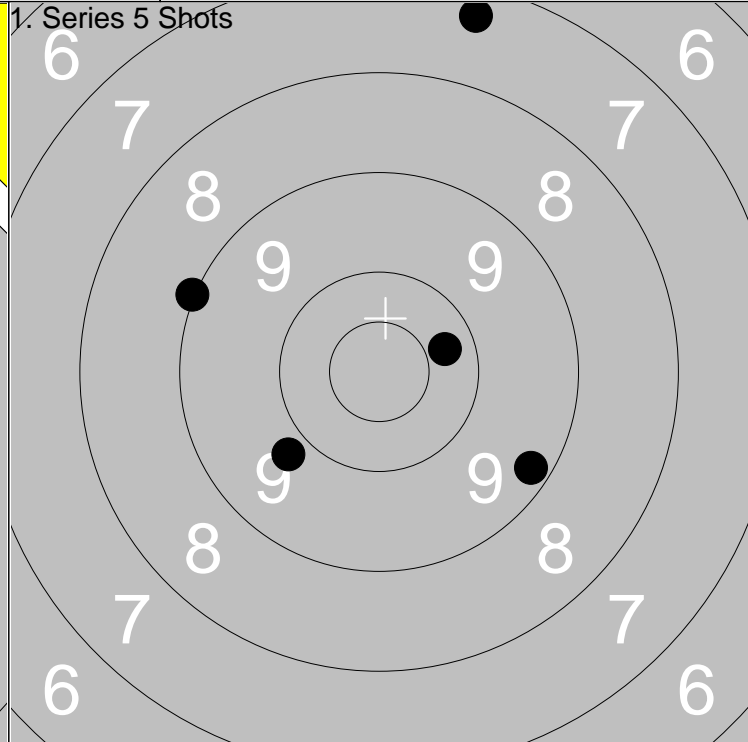
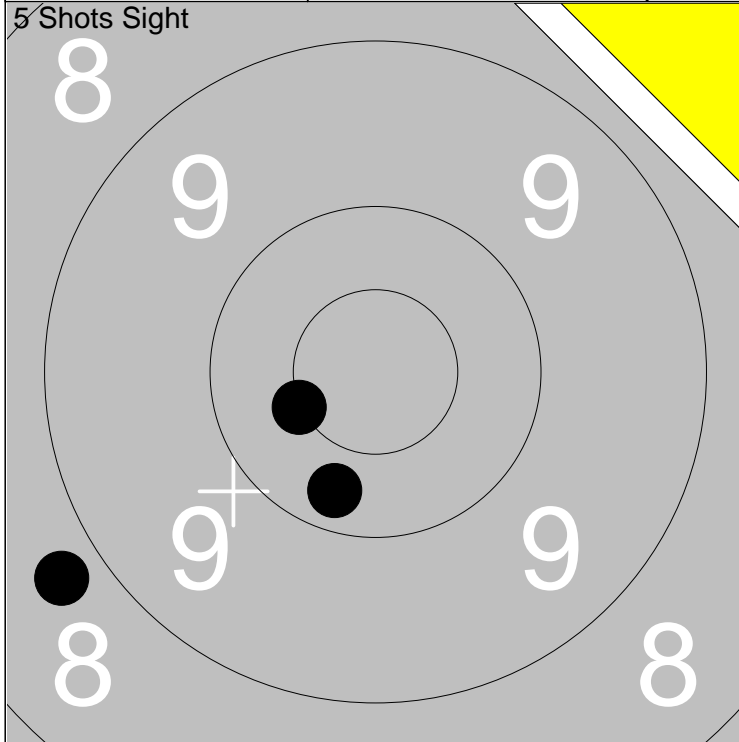

| | | |
|------------|--------|-----------|
| 1: *10.5 ↙ | Series | 28.0 |
| 2: 10.2 ↓ | | |
| 3: 8.8 ↙ | | |
| | | Total 0.0 |

| | | |
|-----------|--------|------------|
| 1: 9.8 ↙ | Series | 44.0 |
| 2: 9.0 ↙ | | |
| 3: 9.2 ↘ | | |
| | | Total 44.0 |
| 4: 7.3 ↑ | | |
| 5: 10.3 ➔ | | |

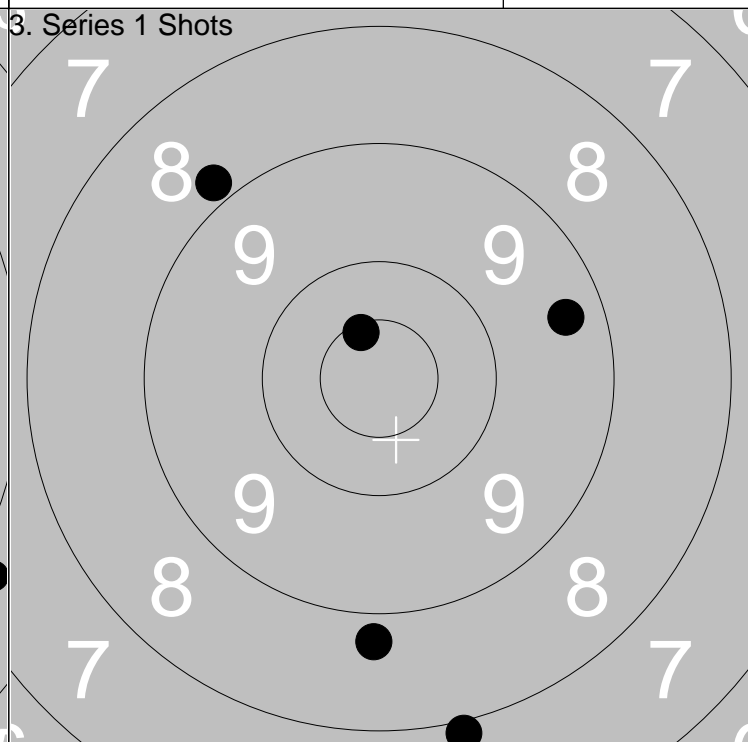
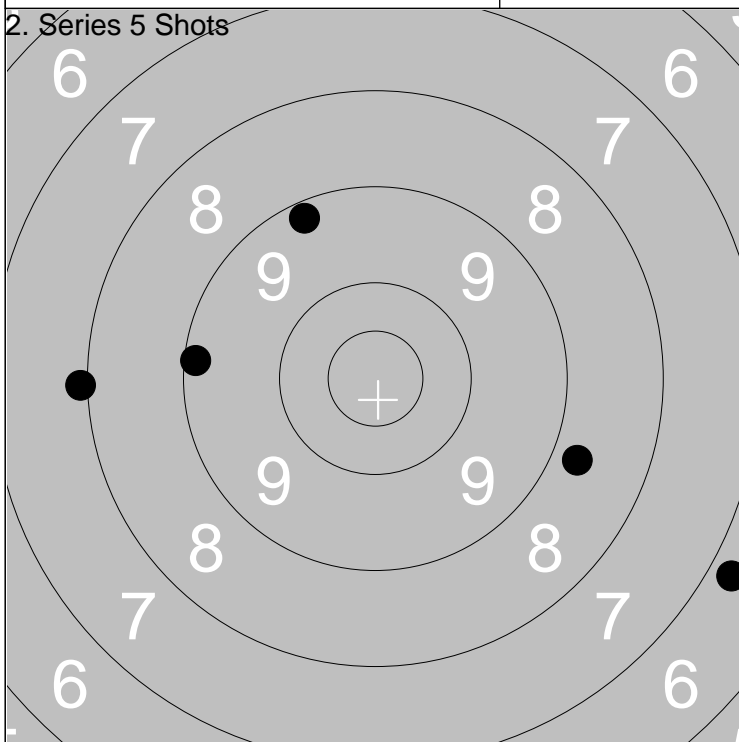

| | | |
|----------|--------|------------|
| 1: 9.2 ↑ | Series | 40.0 |
| 2: 8.0 ↙ | | |
| 3: 8.8 ➔ | | |
| | | Total 84.0 |
| 4: 9.1 ↙ | | |
| 5: 6.8 ↘ | | |

| | | |
|------------|--------|-------------|
| 1: 7.9 ↓ | Series | 42.0 |
| 2: 8.8 ↗ | | |
| 3: 8.8 ↓ | | |
| | | Total 126.0 |
| 4: 9.4 ➔ | | |
| 5: *10.6 ↗ | | |

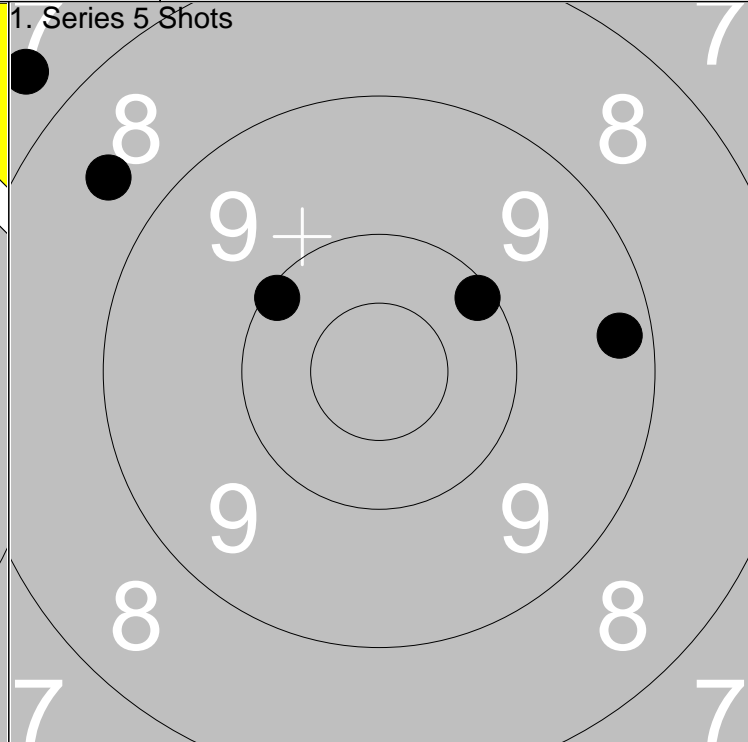
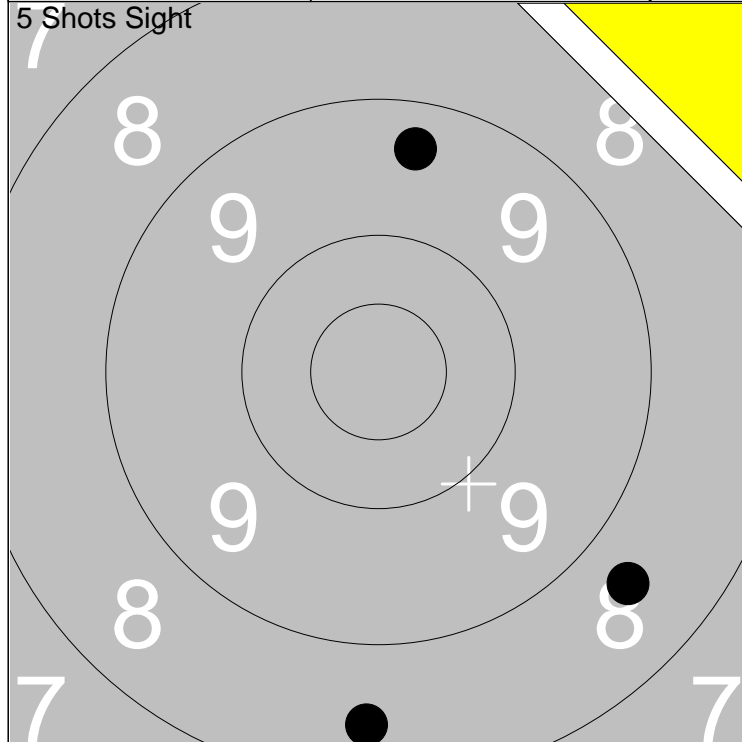

| | |
|-----------|-------------|
| 1: 8.4 ↓ | Series 25.0 |
| 2: 8.6 ↘ | |
| 3: 9.4 ↑ | |
| Total 0.0 | |

| | |
|------------|-------------|
| 1: 8.6 ↗ | Series 44.0 |
| 2: 10.1 ↗ | |
| 3: 9.3 → | |
| 4: 7.7 ↖ | |
| 5: 10.1 ↗ | |
| Total 44.0 | |

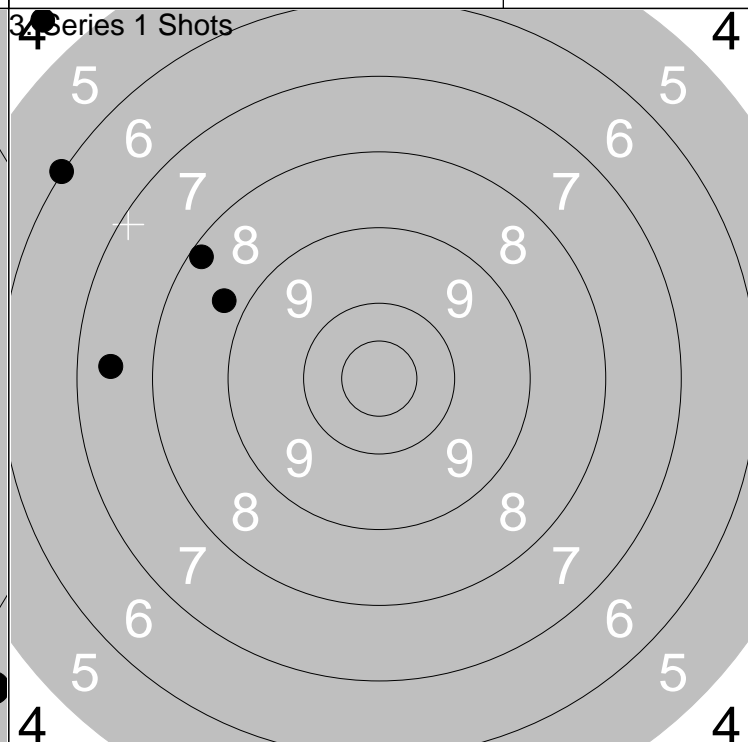
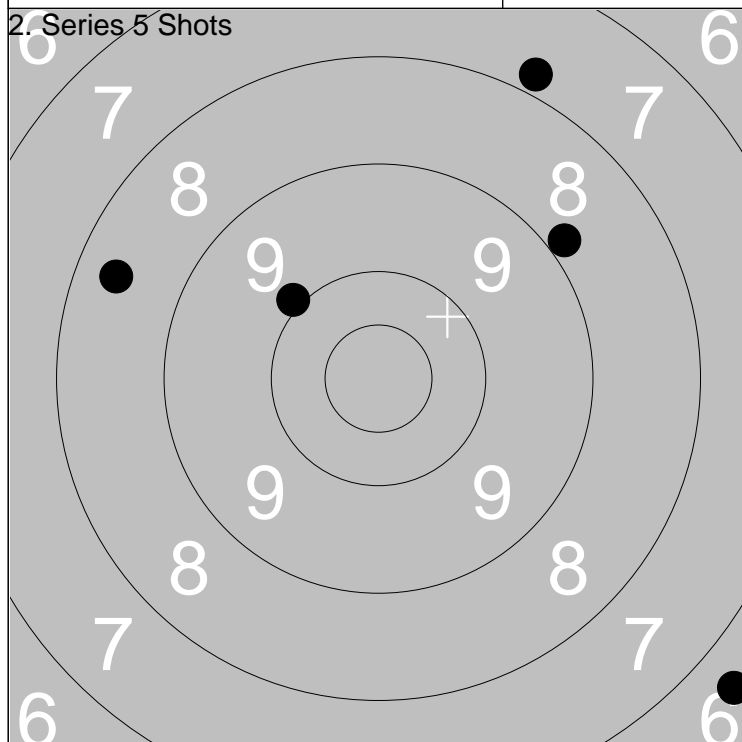

| | |
|------------|-------------|
| 1: 8.4 ↖ | Series 39.0 |
| 2: 10.0 ↖ | |
| 3: 7.8 ↗ | |
| 4: 8.9 ↗ | |
| 5: 6.6 ↘ | |
| Total 83.0 | |

| | |
|-------------|-------------|
| 1: 8.2 ↗ | Series 33.0 |
| 2: 7.5 ← | |
| 3: 8.7 ↖ | |
| 4: 4.5 ↗ | |
| 5: 6.0 ↖ | |
| Total 116.0 | |

Relay **2** Lane **7** **Nils Holmqvist**

300m Stockholm Ä

2013-07-27 Postens Riksmästerskap 2013 Ramselefors SKF

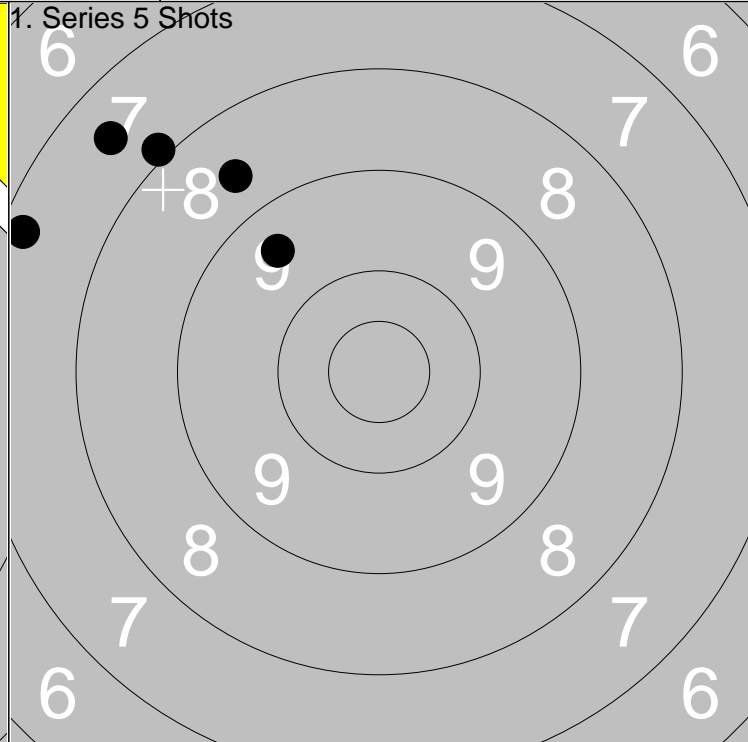
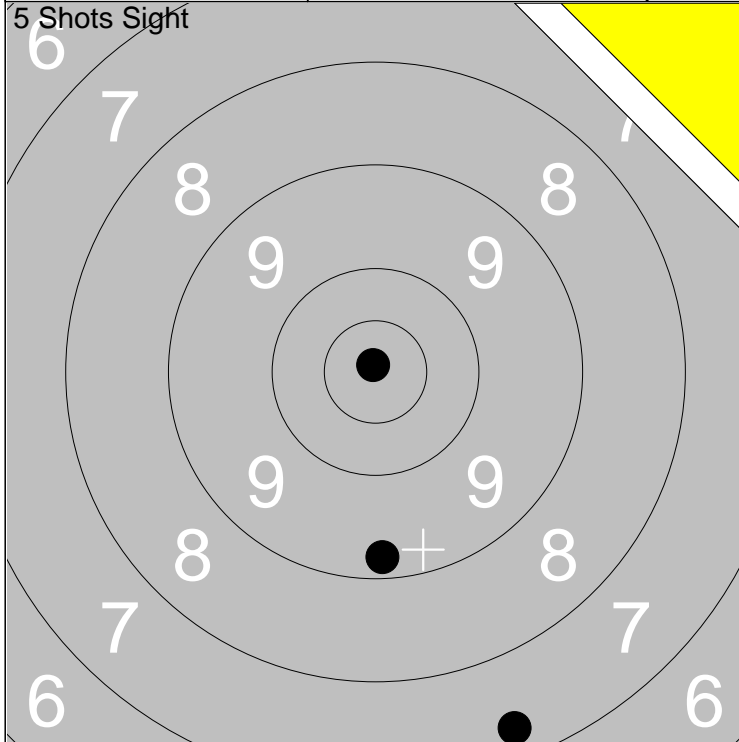

| | | |
|------------|--------|------|
| 1: *10.9 ↑ | Series | 26.0 |
| 2: 7.3 ↓ | Total | 0.0 |
| 3: 9.2 ↓ | | |

| | | |
|----------|--------|------|
| 1: 8.6 ↑ | Series | 38.0 |
| 2: 7.2 ← | Total | 38.0 |
| 3: 7.9 ↑ | | |
| 4: 9.5 ↑ | | |
| 5: 7.5 ↑ | | |

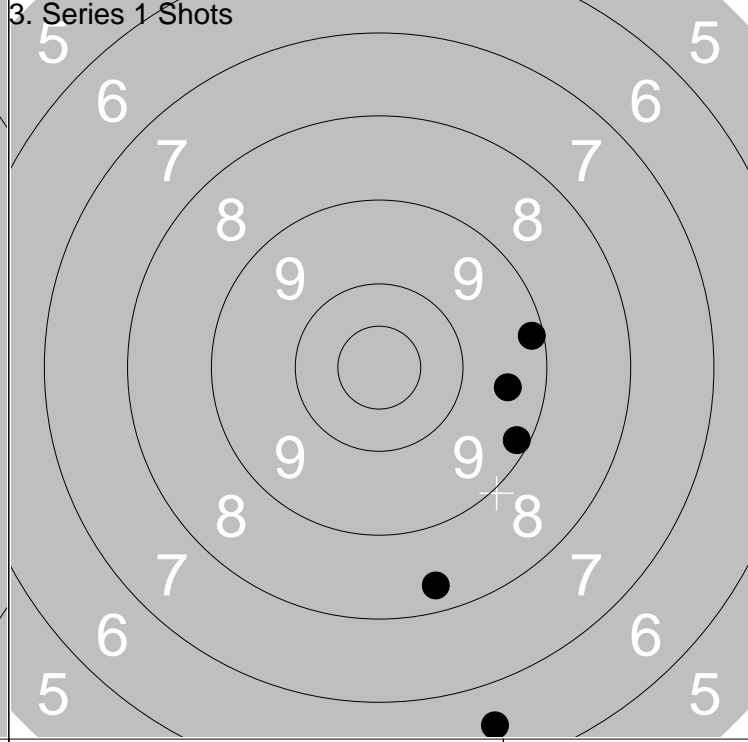
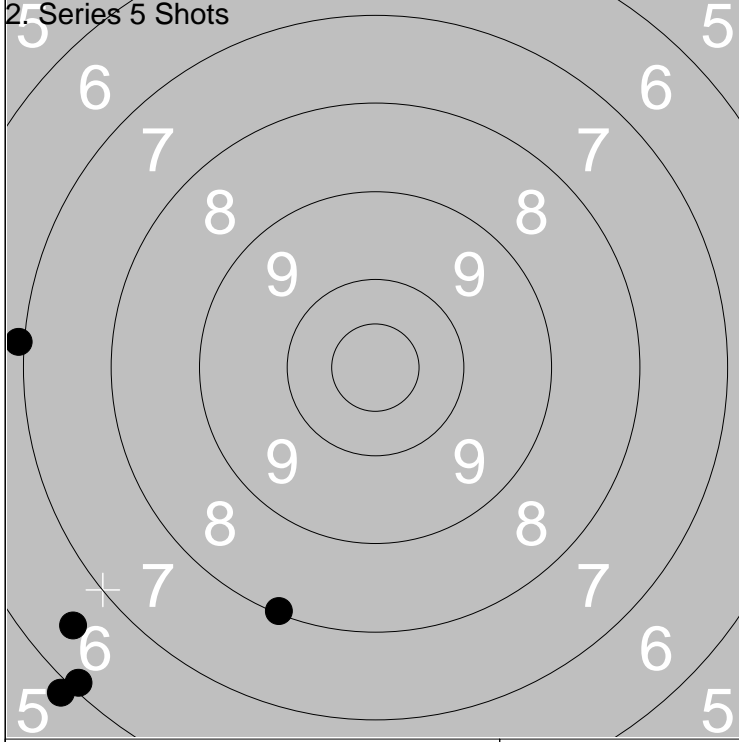

| | | |
|----------|--------|------|
| 1: 6.5 ← | Series | 32.0 |
| 2: 7.0 ← | Total | 70.0 |
| 3: 6.1 ← | | |
| 4: 5.9 ← | | |
| 5: 8.1 ↓ | | |

| | | |
|----------|--------|-------|
| 1: 9.2 → | Series | 41.0 |
| 2: 8.3 ↓ | Total | 111.0 |
| 3: 9.5 → | | |
| 4: 9.2 → | | |
| 5: 6.5 ↓ | | |

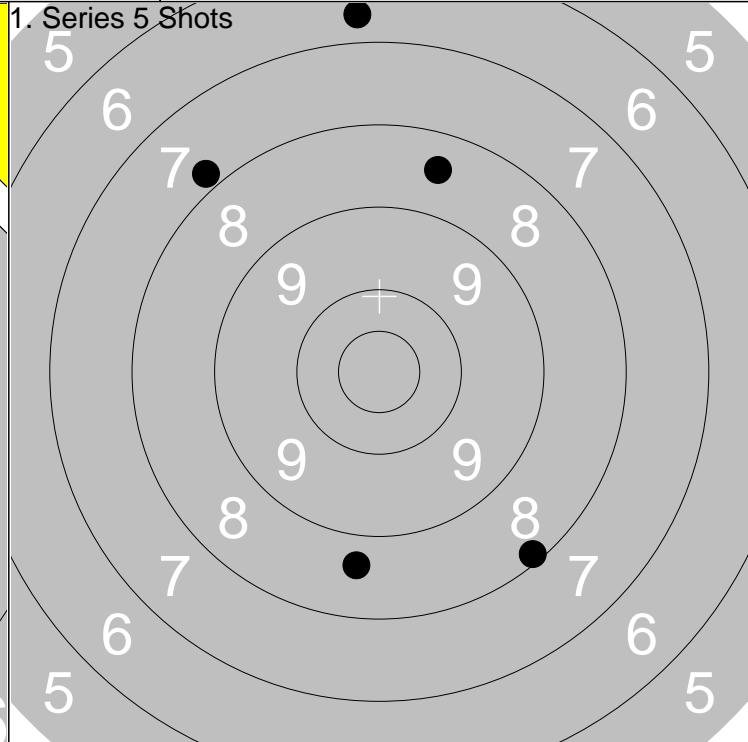

| | | |
|----------|--------|------|
| 1: 7.9 → | Series | 22.0 |
| 2: 7.8 ↑ | | |
| 3: 8.1 → | | |
| Total | | 0.0 |

| | | |
|----------|--------|------|
| 1: 8.5 ↑ | Series | 37.0 |
| 2: 6.7 ↑ | | |
| 3: 7.8 ↖ | | |
| 4: 8.7 ↓ | | |
| 5: 8.1 ↘ | | |
| Total | | 37.0 |

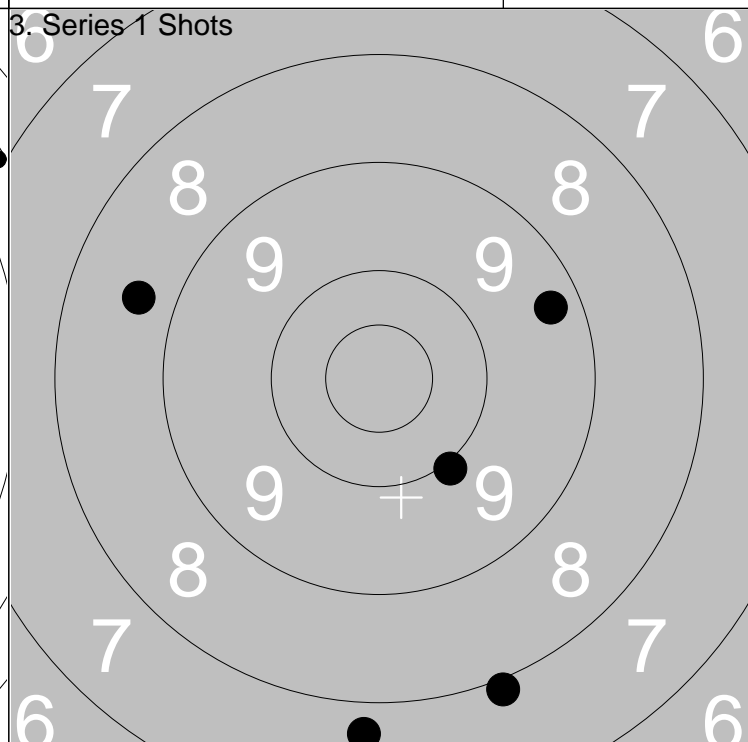
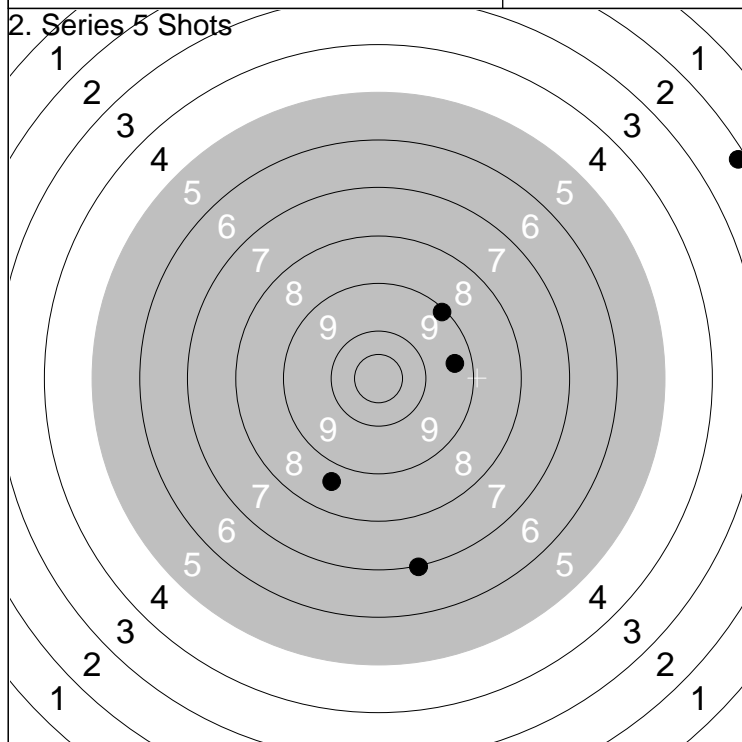

| | | |
|----------|--------|------|
| 1: 8.7 ↓ | Series | 35.0 |
| 2: 9.1 ↗ | | |
| 3: 7.0 ↓ | | |
| 4: 9.4 → | | |
| 5: 2.2 ↗ | | |
| Total | | 72.0 |

| | | |
|-----------|--------|-------|
| 1: 8.7 ↖ | Series | 41.0 |
| 2: 9.3 → | | |
| 3: 10.0 ↓ | | |
| 4: 7.9 ↓ | | |
| 5: 7.7 ↓ | | |
| Total | | 113.0 |

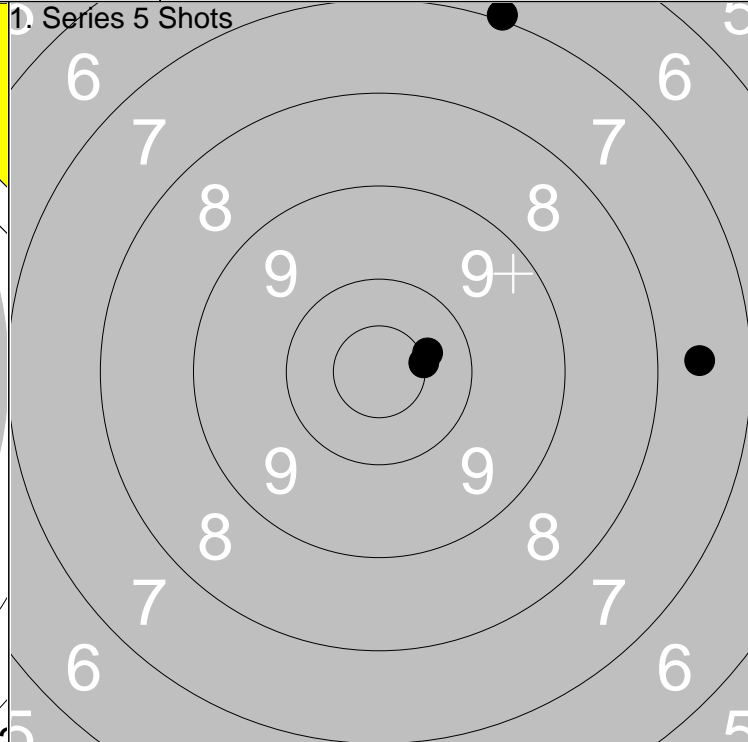
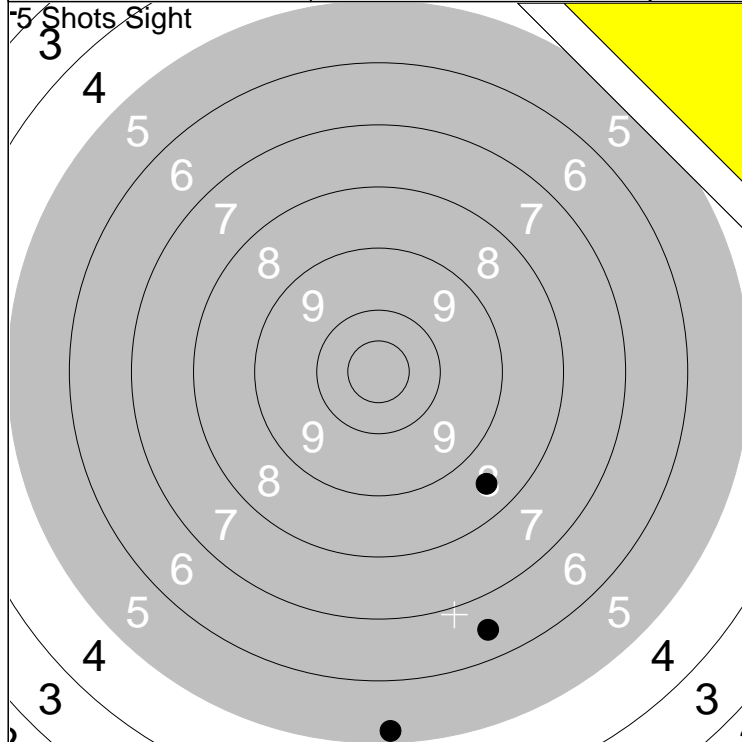

| | |
|-----------|-------------|
| 1: 6.5 ↓ | Series 19.0 |
| 2: 8.5 ↓ | |
| 3: 5.2 ↓ | |
| Total 0.0 | |

| | |
|------------|-------------|
| 1: *10.5 → | Series 34.0 |
| 2: *10.4 → | |
| 3: 7.6 → | |
| 4: 7.0 ↑ | |
| 5: 0.0 | |
| Total 34.0 | |

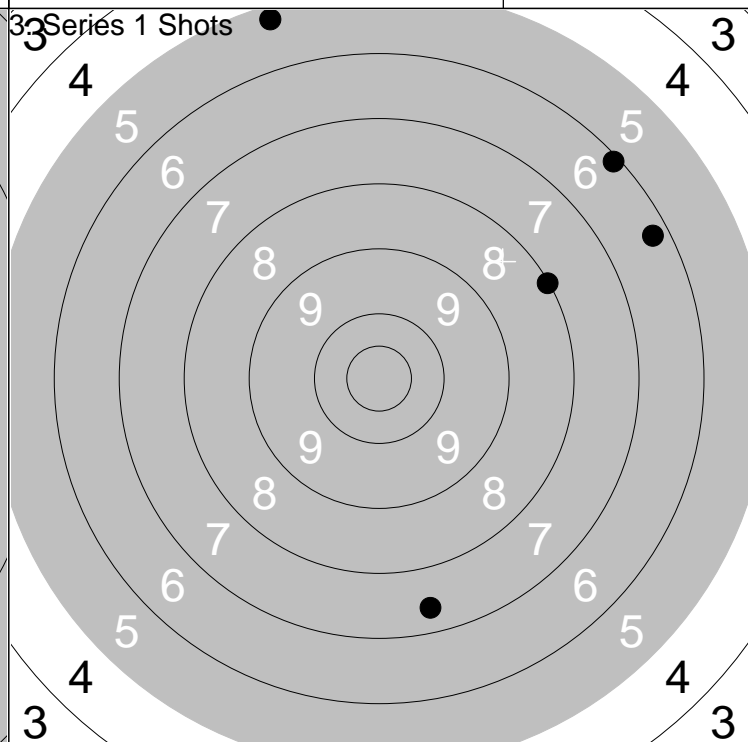
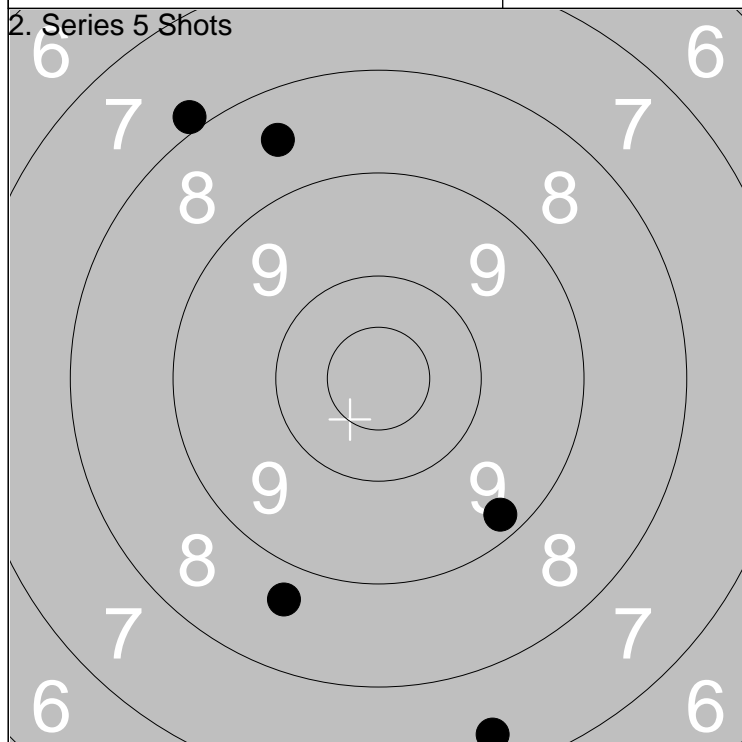

| | |
|------------|-------------|
| 1: 7.9 ↗ | Series 39.0 |
| 2: 8.7 ↓ | |
| 3: 7.4 ↓ | |
| 4: 9.3 ↓ | |
| 5: 8.5 ↗ | |
| Total 73.0 | |

| | |
|-------------|-------------|
| 1: 7.4 ↓ | Series 32.0 |
| 2: 6.1 ↗ | |
| 3: 8.0 ↗ | |
| 4: 6.3 ↗ | |
| 5: 5.3 ↑ | |
| Total 105.0 | |

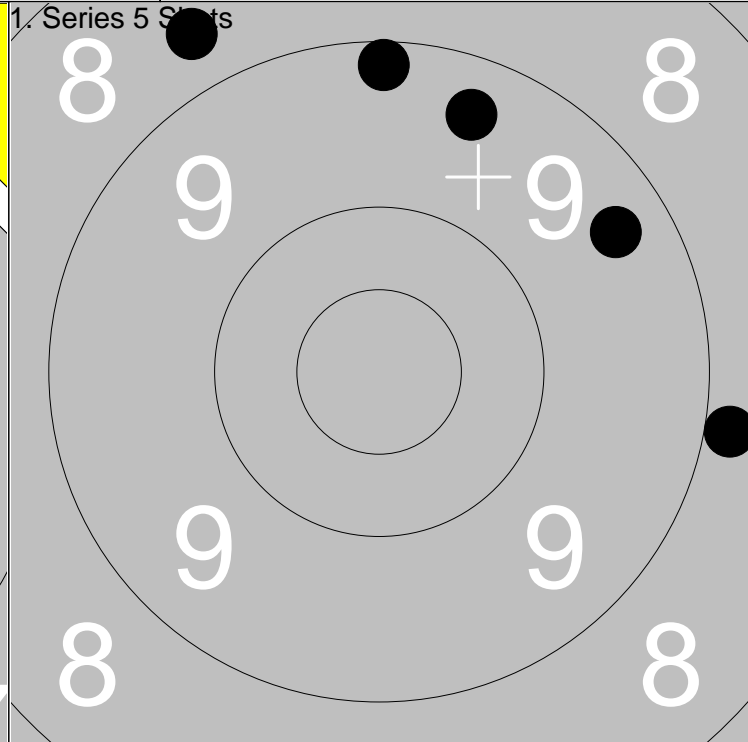
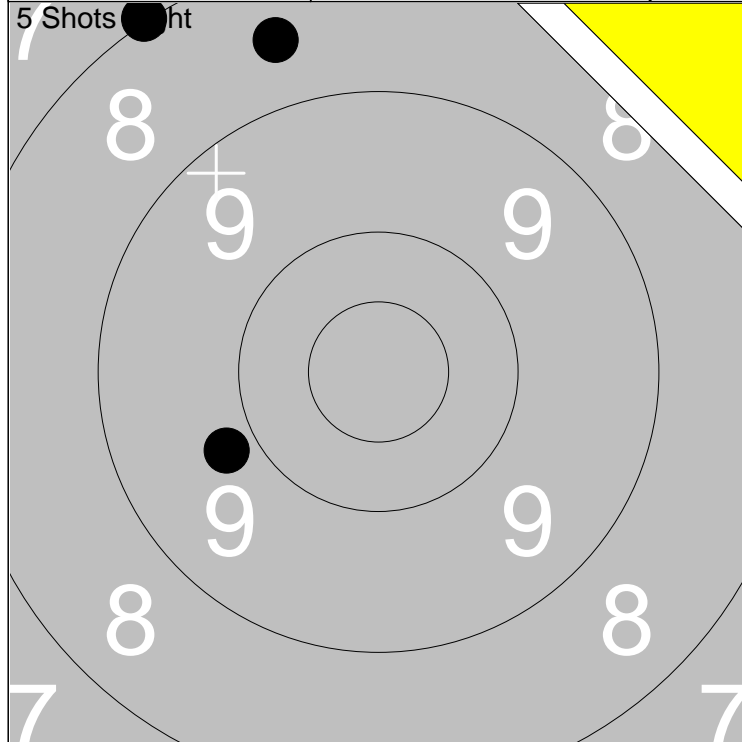

| | |
|--------------|----------------|
| 1: 8.0 ↗ | Series 25.0 |
| 2: 8.6 ↑ | |
| 3: 9.8 ↖ | |
| Total 0.0 | |

| | |
|---------------|----------------|
| 1: 9.2 ↑ | Series 43.0 |
| 2: 8.7 ↖ | |
| 3: 8.9 → | |
| 4: 9.4 ↑ | |
| 5: 9.4 ↗ | |
| Total 43.0 | |

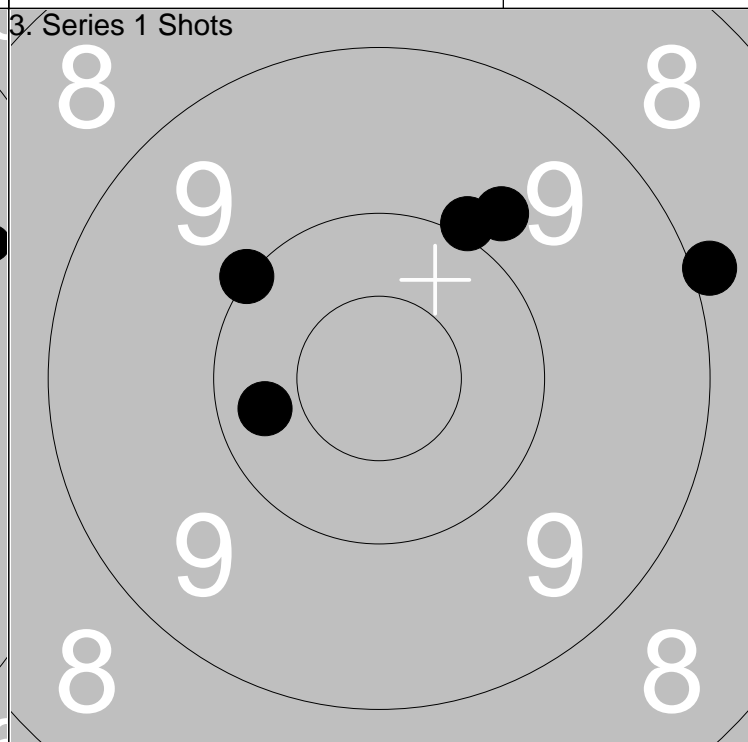
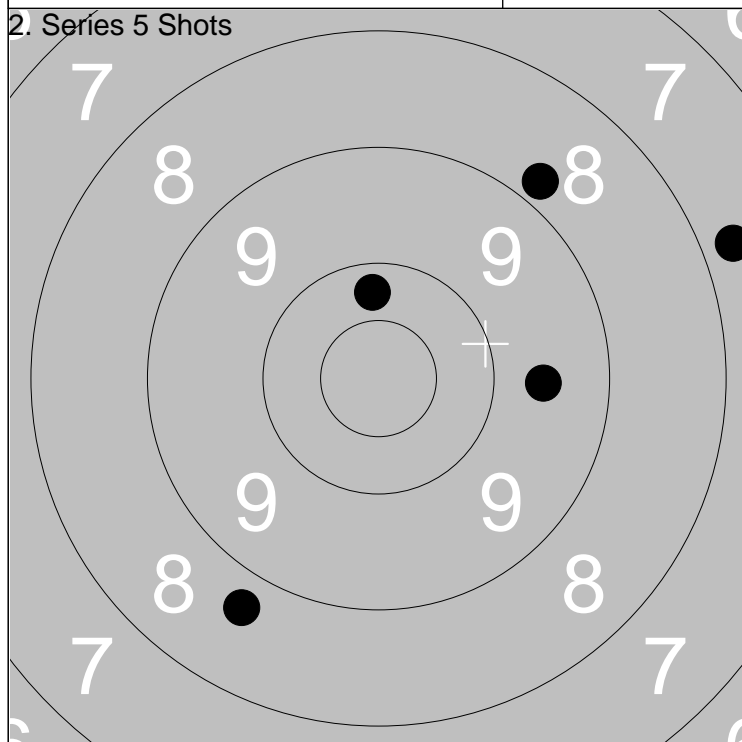

| | |
|---------------|----------------|
| 1: 10.3 ↑ | Series 42.0 |
| 2: 8.7 ↘ | |
| 3: 7.8 ↗ | |
| 4: 9.6 → | |
| 5: 8.8 ↗ | |
| Total 85.0 | |

| | |
|----------------|----------------|
| 1: 8.9 → | Series 47.0 |
| 2: 10.0 ↖ | |
| 3: 9.8 ↗ | |
| 4: 10.0 ↑ | |
| 5: 10.3 ↖ | |
| Total 132.0 | |

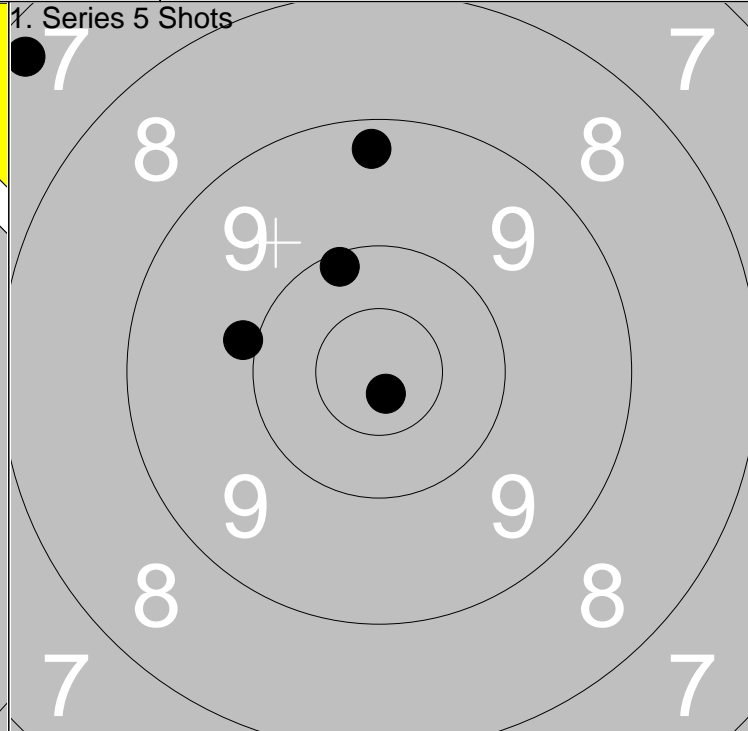
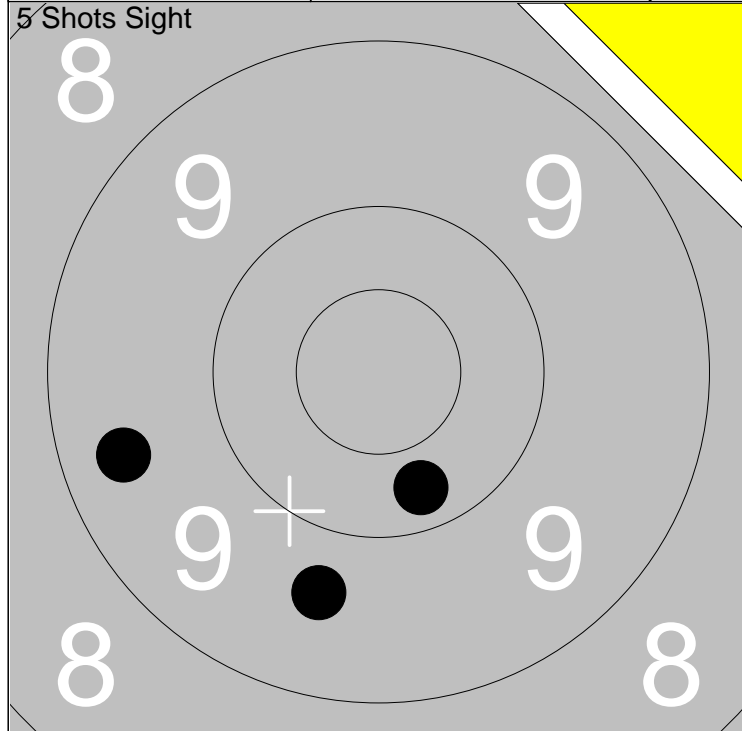

| | | |
|-----------|--------|------|
| 1: 9.6 ↓ | Series | 28.0 |
| 2: 9.4 ← | | |
| 3: 10.3 ↓ | | |
| Total | | 0.0 |

| | | |
|------------|--------|------|
| 1: 7.3 ↖ | Series | 45.0 |
| 2: 9.9 ← | | |
| 3: 9.3 ↑ | | |
| 4: 10.1 ↗ | | |
| 5: *10.8 ↓ | | |
| Total | | 45.0 |

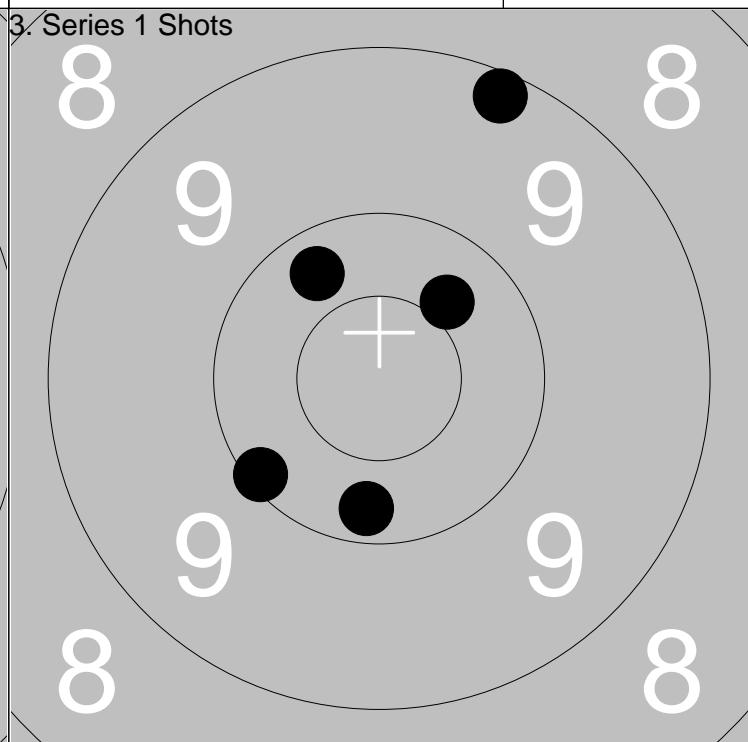
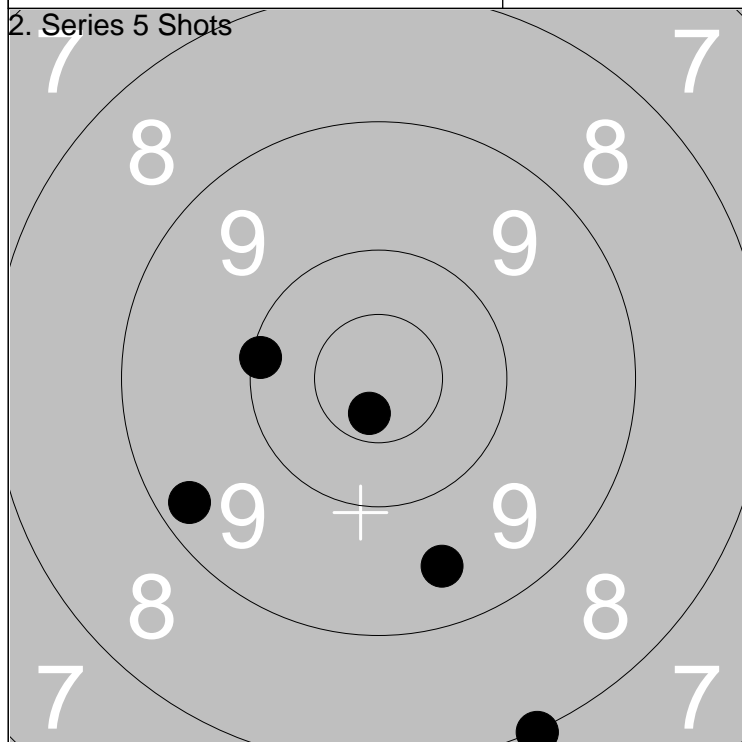

| | | |
|------------|--------|------|
| 1: 9.3 ← | Series | 46.0 |
| 2: 9.5 ↓ | | |
| 3: 10.1 ← | | |
| 4: *10.7 ↓ | | |
| 5: 8.0 ↓ | | |
| Total | | 91.0 |

| | | |
|-----------|--------|-------|
| 1: 10.1 ↖ | Series | 49.0 |
| 2: 10.2 ↓ | | |
| 3: 10.3 ↗ | | |
| 4: 9.2 ↑ | | |
| 5: 10.4 ↗ | | |
| Total | | 140.0 |

| | | | |
|-------------------|-------------------|---------------------|--|
| Relay 2 | Lane 15 | Tony Jansson | |
|-------------------|-------------------|---------------------|--|

| | | |
|------|-----------|---|
| 300m | Norrtälje | H |
|------|-----------|---|

| | | |
|------------|-----------------------------|-----------------|
| 2013-07-27 | Postens Riksmästerskap 2013 | Ramselefors SKF |
|------------|-----------------------------|-----------------|

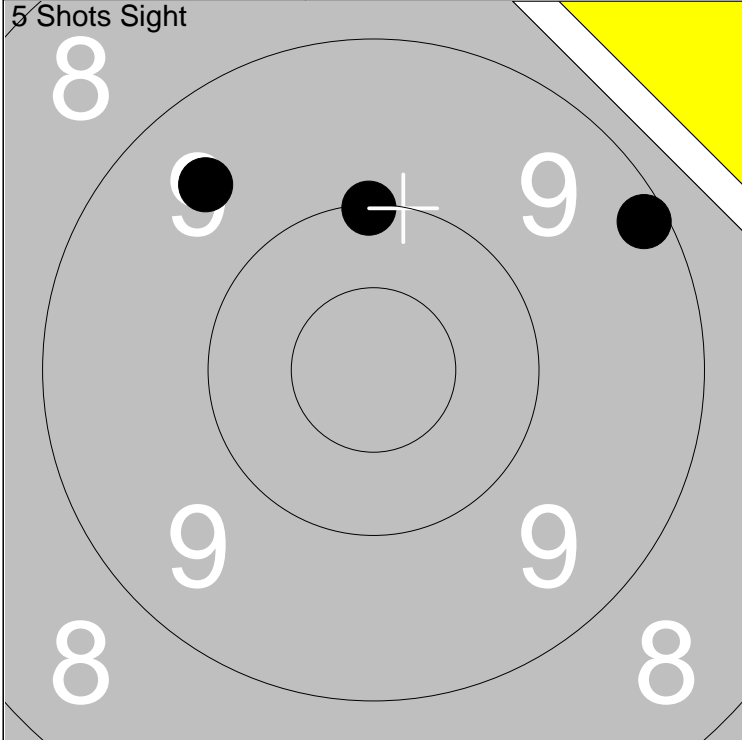

| | | |
|-----------|--------|------|
| 1: 10.0 ↑ | Series | 28.0 |
| 2: 9.2 ↗ | | |
| 3: 9.5 ↖ | | |
| Total | | 0.0 |

| | | |
|------------|--------|------|
| 1: 8.0 ↗ | Series | 45.0 |
| 2: 9.7 ↗ | | |
| 3: 9.9 ← | | |
| 4: *10.4 ↘ | | |
| 5: 9.5 ← | | |
| Total | | 45.0 |

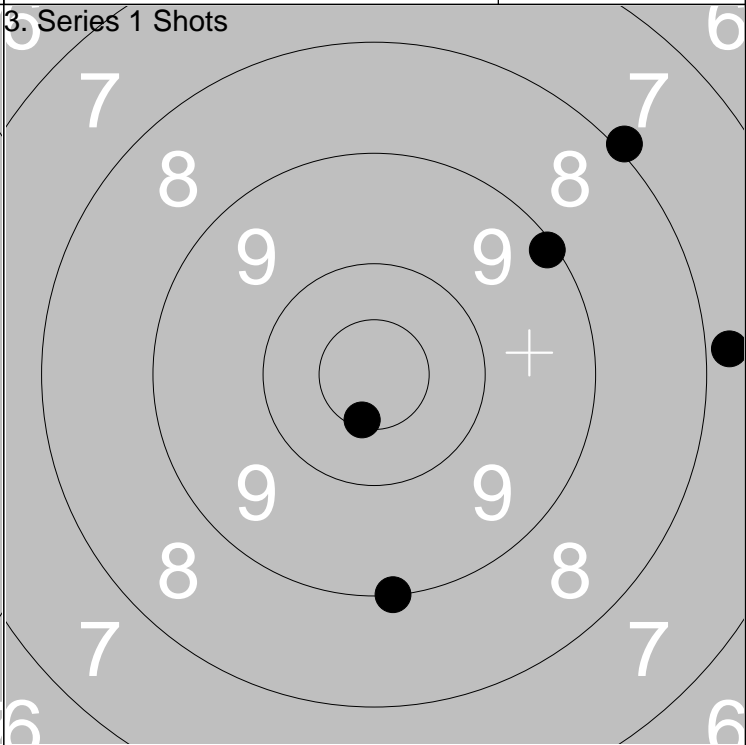
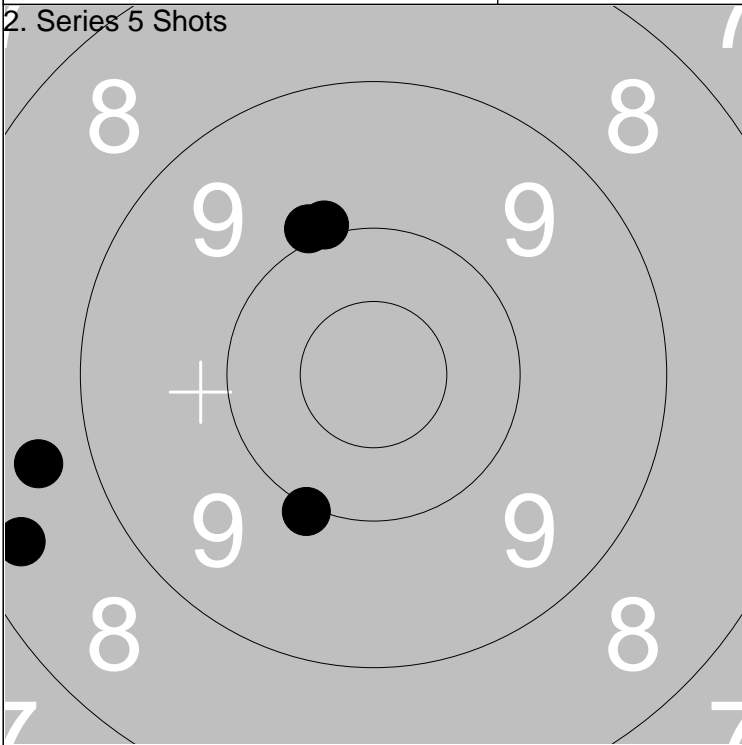

| | | |
|-----------|--------|------|
| 1: 8.7 ← | Series | 45.0 |
| 2: 9.9 ↖ | | |
| 3: 8.4 ← | | |
| 4: 10.0 ↑ | | |
| 5: 10.0 ↓ | | |
| Total | | 90.0 |

| | | |
|------------|--------|-------|
| 1: 8.0 ↗ | Series | 43.0 |
| 2: 9.1 ↗ | | |
| 3: 9.0 ↓ | | |
| 4: *10.6 ↓ | | |
| 5: 7.8 → | | |
| Total | | 133.0 |

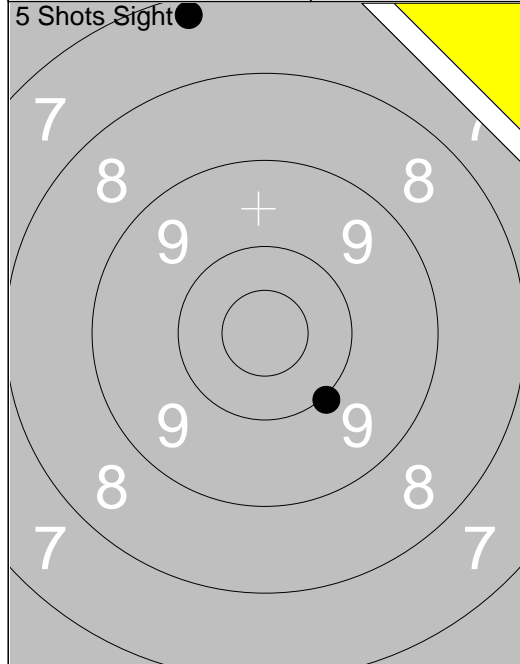

| | |
|--------------------|--------|
| 1: | 10.0 ↘ |
| 2: | 7.3 ↑ |
| Series 17.0 | |
| Total 0.0 | |

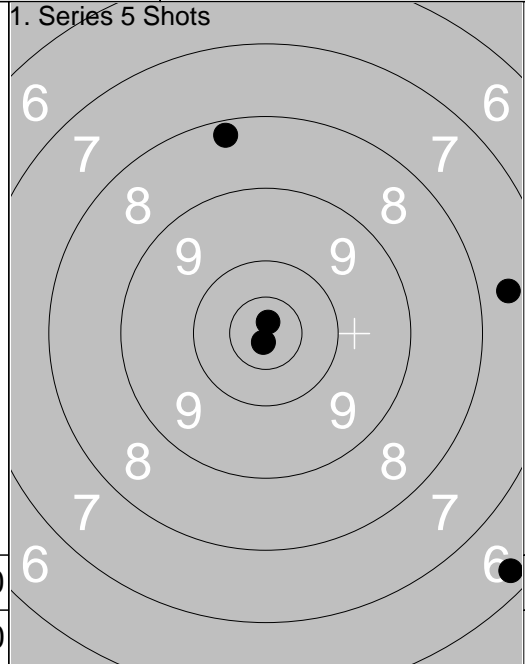

| | |
|--------------------|---------|
| 1: | 6.3 ↘ |
| 2: | 7.6 → |
| 3: | 8.2 ↑ |
| 4: | *10.8 ↑ |
| 5: | *10.8 ↓ |
| Series 41.0 | |
| Total 41.0 | |

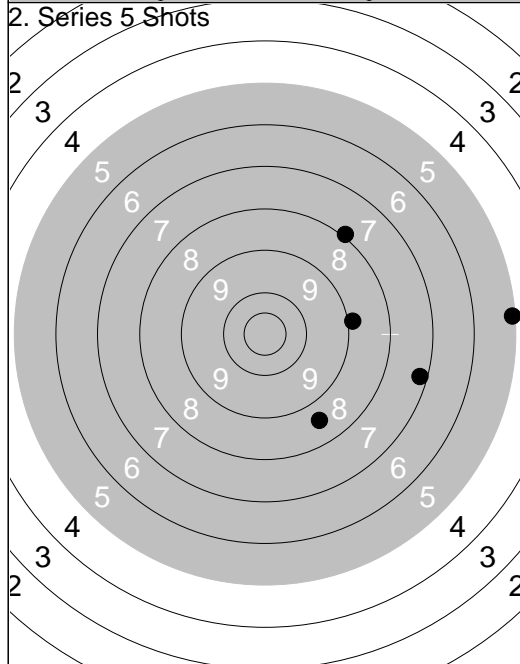

| | |
|--------------------|-------|
| 1: | 8.9 → |
| 2: | 7.2 → |
| 3: | 8.6 ↘ |
| 4: | 5.1 → |
| 5: | 8.0 ↗ |
| Series 36.0 | |
| Total 77.0 | |

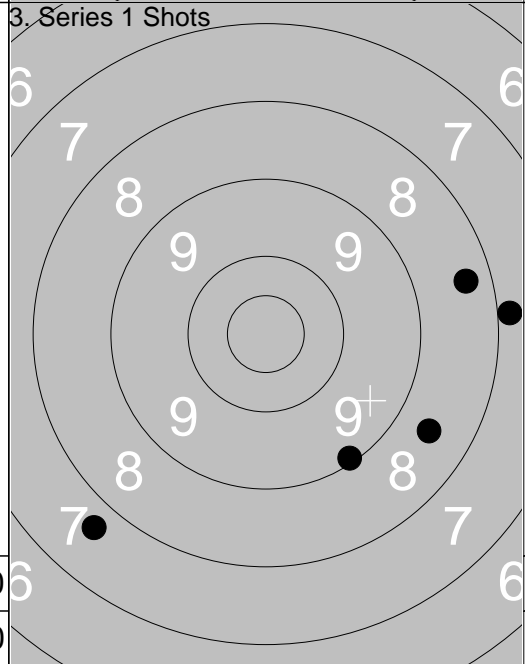

| | |
|--------------------|-------|
| 1: | 8.4 → |
| 2: | 8.6 ↘ |
| 3: | 7.9 → |
| 4: | 9.1 ↘ |
| 5: | 7.7 ↙ |
| Series 39.0 | |
| Total 116.0 | |

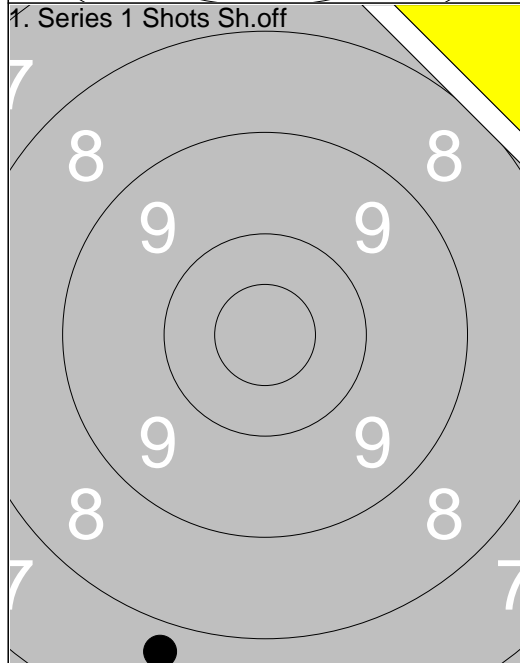

| | |
|--------------------|-------|
| 1: | 7.7 ↓ |
| Series 7.0 | |
| Total 116.0 | |

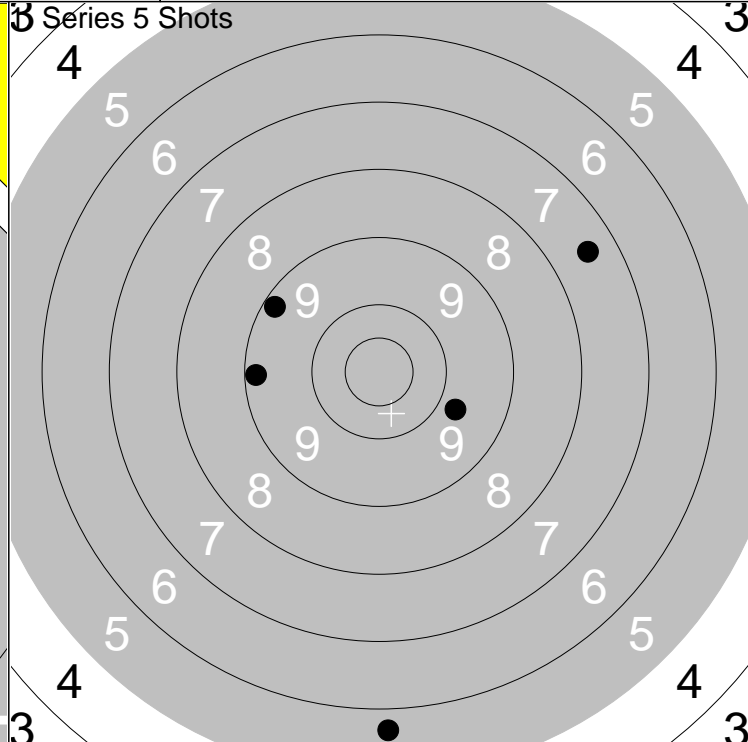
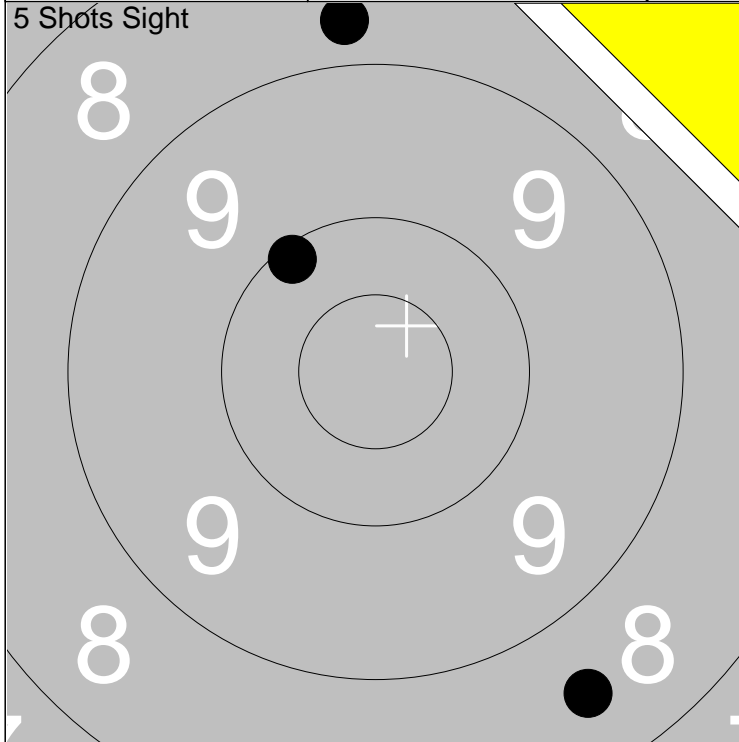

| | | |
|-----------|--------|------|
| 1: 10.1 ↗ | Series | 26.0 |
| 2: 8.5 ↘ | | |
| 3: 8.7 ↑ | | |
| Total | | 0.0 |

| | | |
|----------|--------|------|
| 1: 5.7 ↓ | Series | 39.0 |
| 2: 9.2 ← | | |
| 3: 9.8 → | | |
| 4: 7.5 ↗ | | |
| 5: 9.2 ↖ | | |
| Total | | 39.0 |

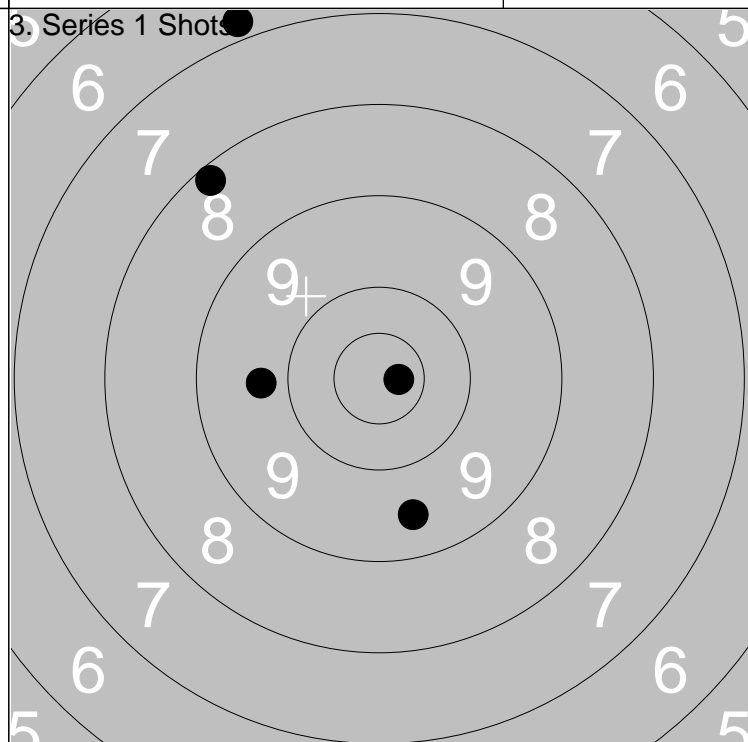
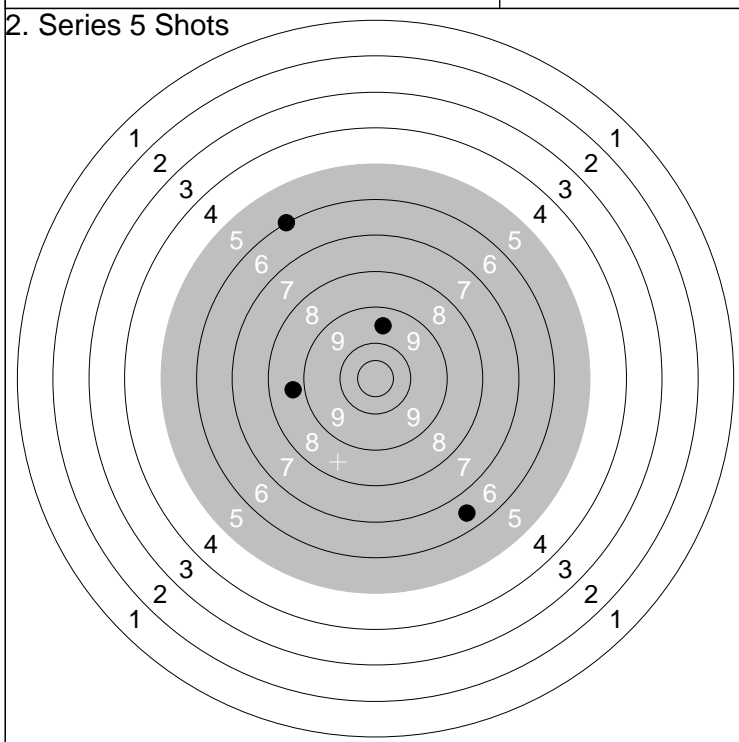

| | | |
|----------|--------|------|
| 1: 6.0 ↗ | Series | 29.0 |
| 2: 8.7 ← | | |
| 3: 9.5 ↑ | | |
| 4: 0.0 ↓ | | |
| 5: 6.5 ↘ | | |
| Total | | 68.0 |

| | | |
|------------|--------|-------|
| 1: 9.5 ↓ | Series | 42.0 |
| 2: *10.8 → | | |
| 3: 9.7 ← | | |
| 4: 8.2 ↗ | | |
| 5: 6.8 ↖ | | |
| Total | | 110.0 |

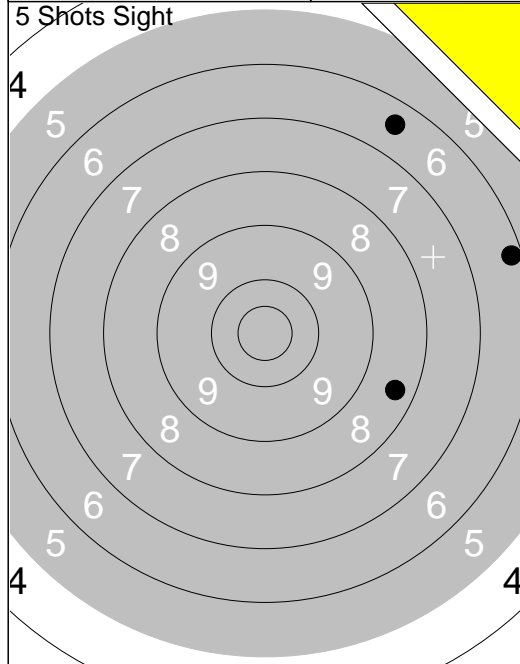

| |
|-------------|
| 1: 6.5 ↗ |
| 2: 6.2 → |
| 3: 8.4 → |
| 4: 6.5 → |
| 5: 8.4 → |
| Series 20.0 |
| Total 0.0 |

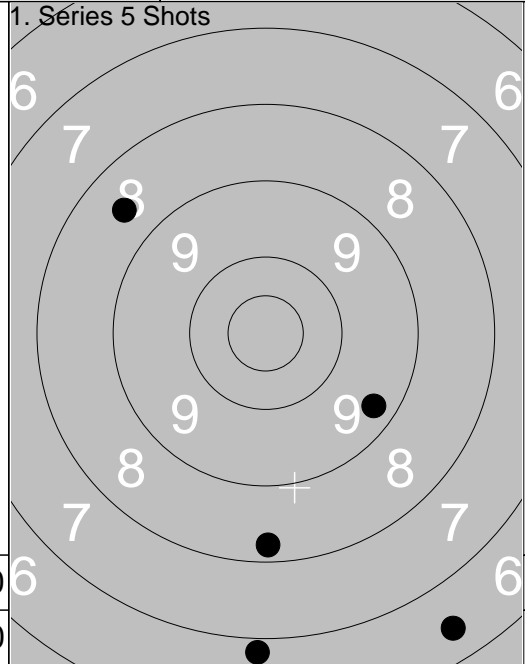

| |
|-------------|
| 1: 6.8 ↓ |
| 2: 6.5 ↓ |
| 3: 9.3 ↘ |
| 4: 8.6 ↗ |
| 5: 8.3 ↓ |
| Series 37.0 |
| Total 37.0 |

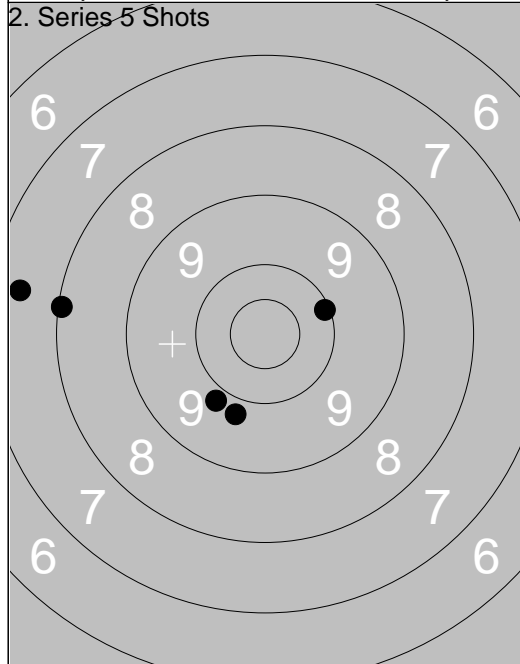

| |
|-------------|
| 1: 8.1 ← |
| 2: 9.8 ↓ |
| 3: 10.1 → |
| 4: 7.5 ← |
| 5: 9.8 ↓ |
| Series 43.0 |
| Total 80.0 |

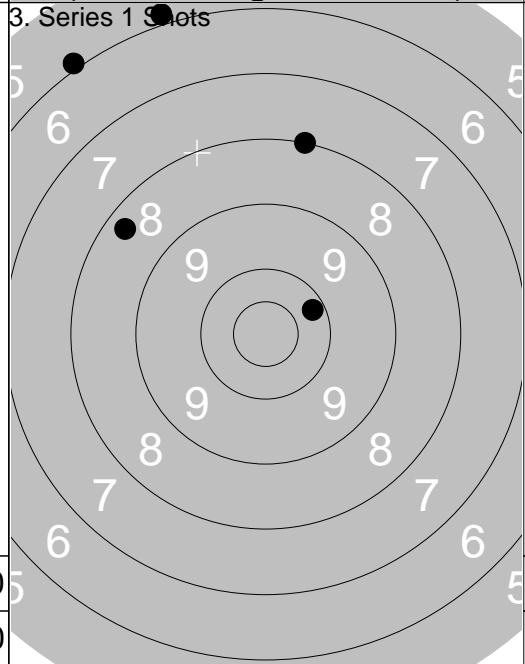

| |
|-------------|
| 1: 8.0 ↑ |
| 2: 5.9 ↗ |
| 3: 10.2 → |
| 4: 5.9 ↑ |
| 5: 8.3 ↗ |
| Series 36.0 |
| Total 116.0 |

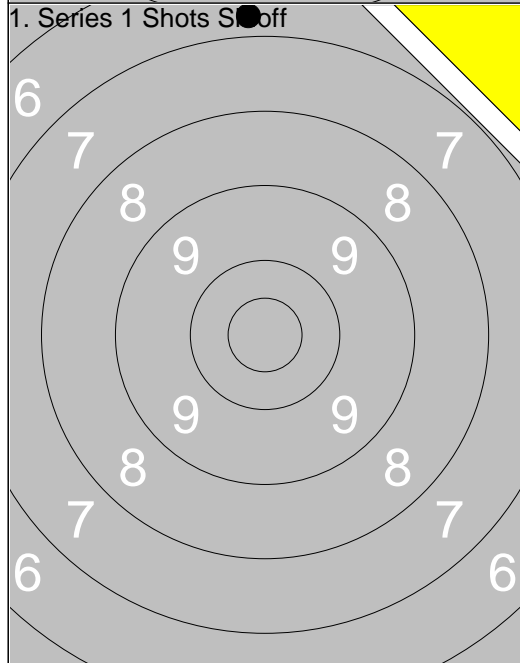

| |
|-------------|
| 1: 6.7 ↑ |
| Series 6.0 |
| Total 116.0 |

Relay **3** Lane **1** **Leif Sigfridsson**

300m Umeå H

2013-07-27 Postens Riksmästerskap 2013 Ramselefors SKF

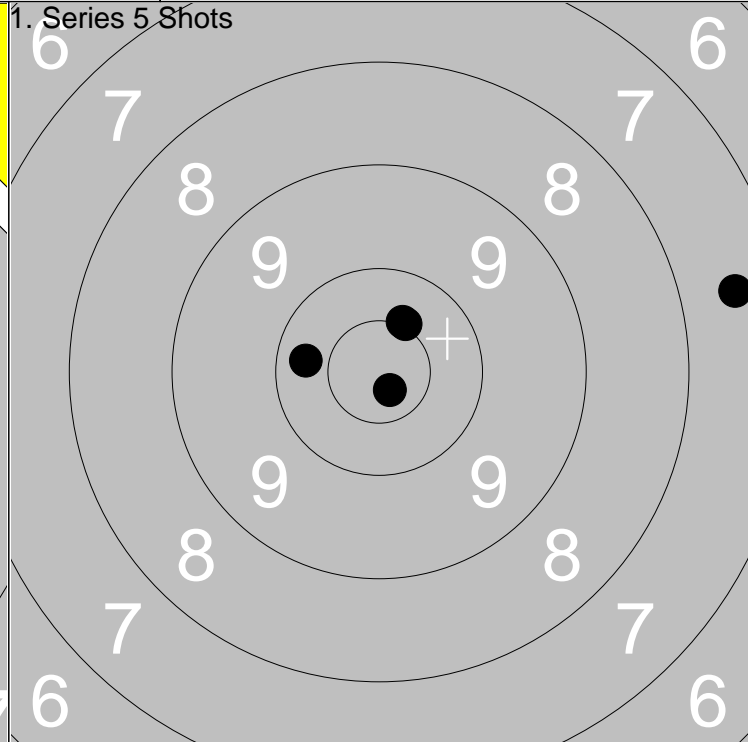
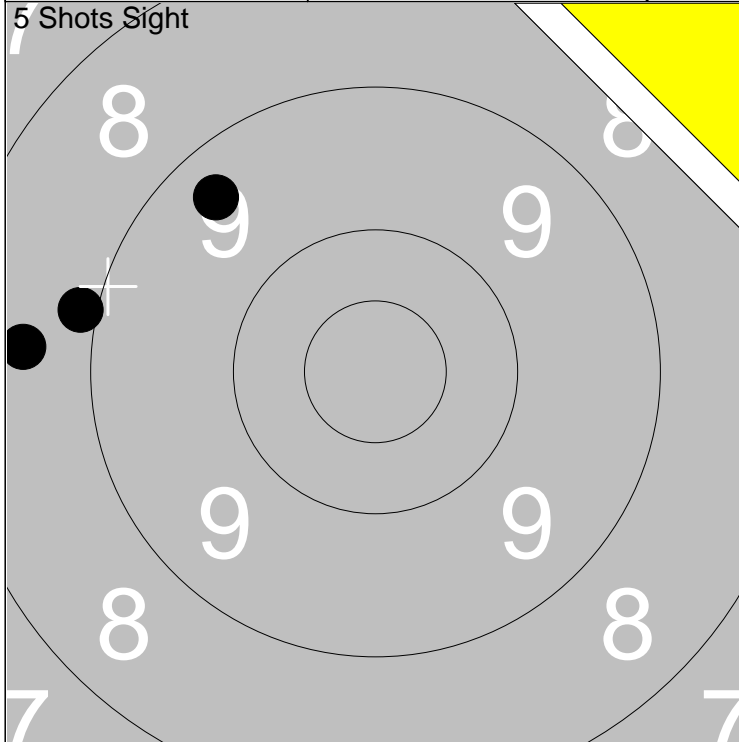

| | |
|-----------|-------------|
| 1: 9.4 ↗ | Series 25.0 |
| 2: 8.9 ← | |
| 3: 8.5 ← | |
| Total 0.0 | |

| | |
|------------|-------------|
| 1: 7.5 → | Series 47.0 |
| 2: *10.8 ↘ | |
| 3: *10.5 ↗ | |
| 4: 10.3 ← | |
| 5: *10.5 ↗ | |
| Total 47.0 | |

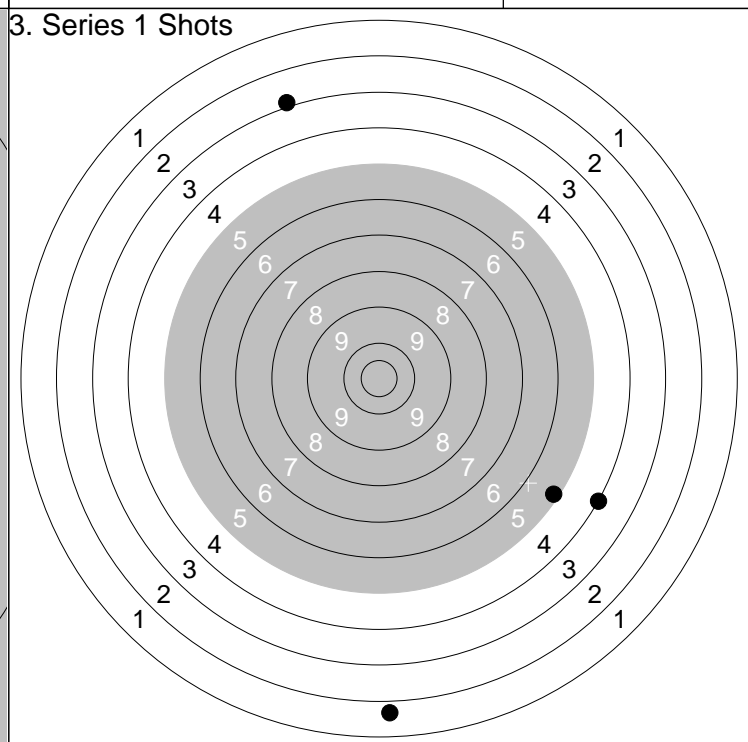
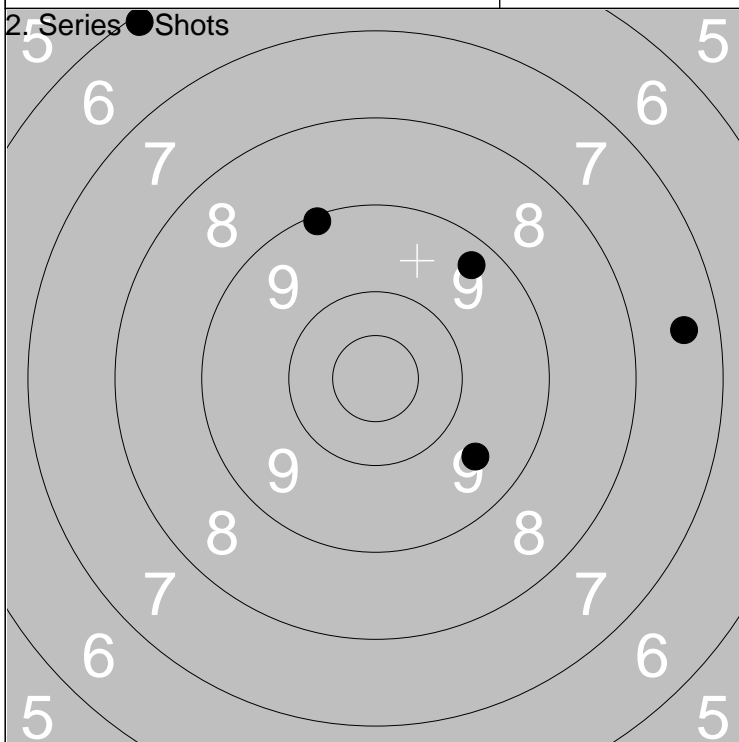

| | |
|------------|-------------|
| 1: 9.6 ↘ | Series 40.0 |
| 2: 7.4 → | |
| 3: 6.1 ↗ | |
| 4: 9.1 ↗ | |
| 5: 9.3 ↗ | |
| Total 87.0 | |

| | |
|------------|-------------|
| 1: 0.0 → | Series 12.0 |
| 2: 1.7 ↓ | |
| 3: 2.9 ↗ | |
| 4: 4.0 ↘ | |
| 5: 5.2 ↘ | |
| Total 99.0 | |

Relay **3** Lane **2** **Tony Jansson**

300m Norrtälje H

2013-07-27 Postens Riksmästerskap 2013 Ramselefors SKF

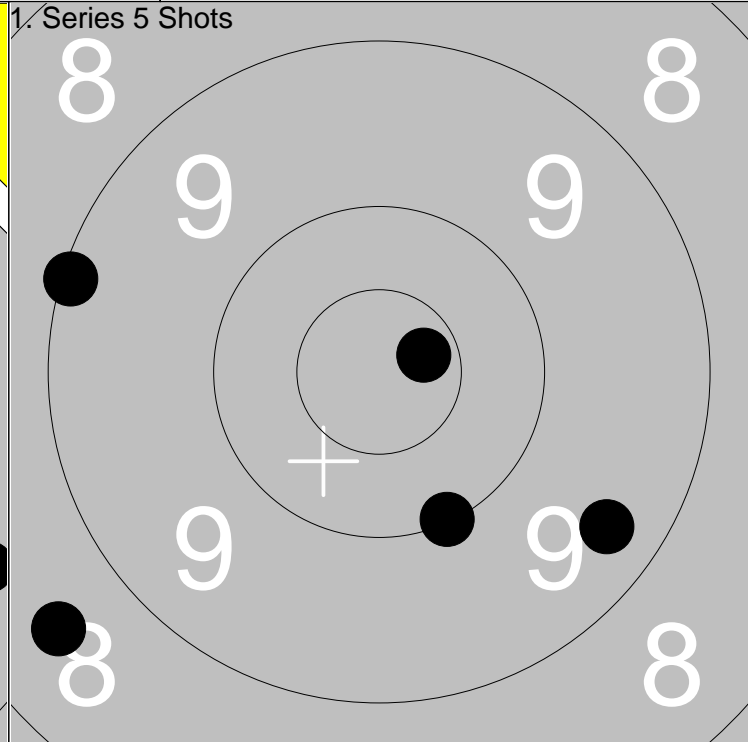
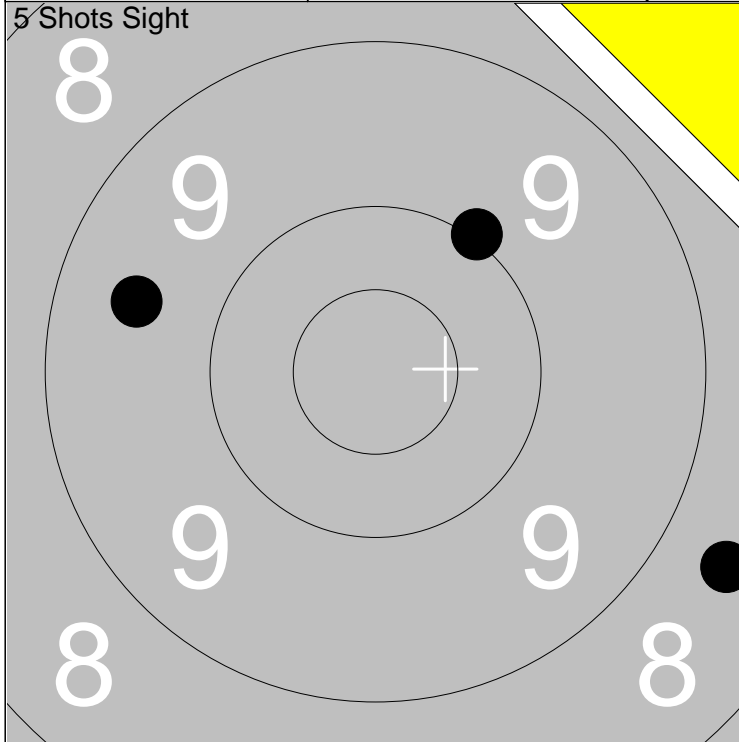

| | |
|-----------|-------------|
| 1: 8.6 ↘ | Series 27.0 |
| 2: 9.5 ← | |
| 3: 10.0 ↗ | |
| Total 0.0 | |

| | |
|------------|-------------|
| 1: 10.0 ↓ | Series 46.0 |
| 2: 9.1 ← | |
| 3: *10.7 → | |
| 4: 8.5 ↙ | Total 46.0 |
| 5: 9.4 ↘ | |

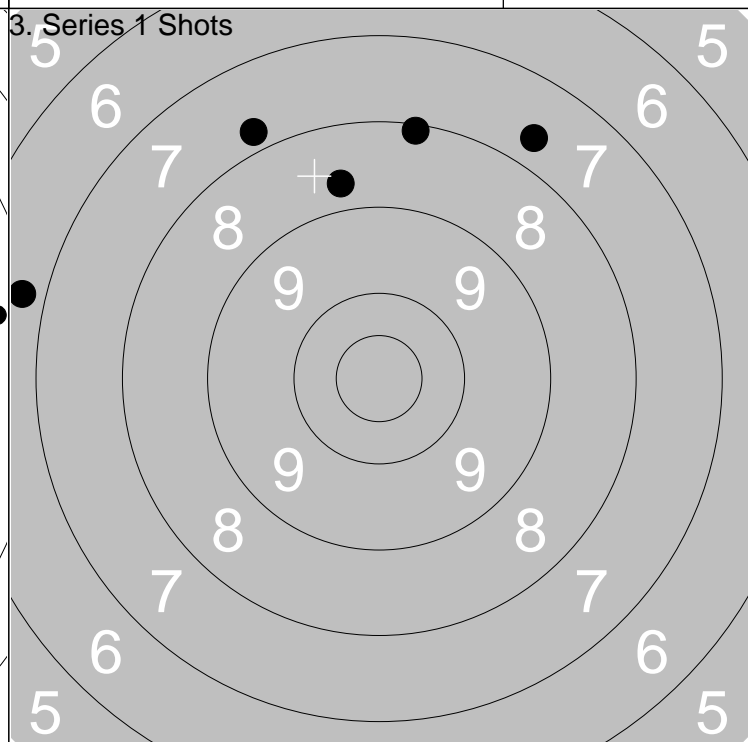
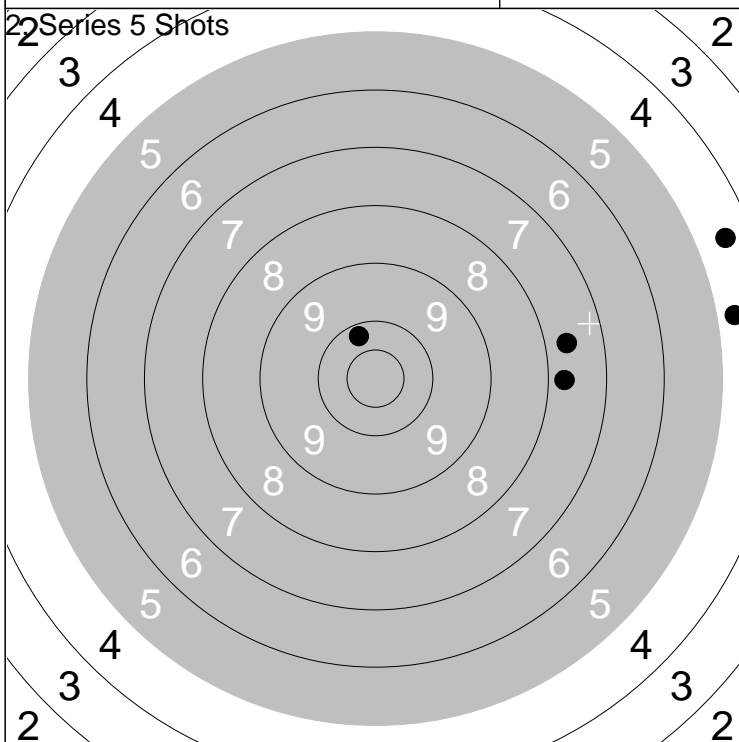

| | |
|-----------|-------------|
| 1: 4.5 → | Series 32.0 |
| 2: 4.7 → | |
| 3: 10.2 ↖ | |
| 4: 7.8 → | Total 78.0 |
| 5: 7.7 → | |

| | |
|----------|-------------|
| 1: 6.7 ← | Series 36.0 |
| 2: 7.7 ↗ | |
| 3: 7.8 ↖ | |
| 4: 8.1 ↑ | Total 114.0 |
| 5: 8.7 ↑ | |

| | | | |
|-------------------|------------------|------------------------|--|
| Relay 3 | Lane 3 | Klas Gustafsson | |
|-------------------|------------------|------------------------|--|

| | | |
|------|-----------|---|
| 300m | Stockholm | H |
|------|-----------|---|

| | | |
|------------|-----------------------------|-----------------|
| 2013-07-27 | Postens Riksmästerskap 2013 | Ramselefors SKF |
|------------|-----------------------------|-----------------|

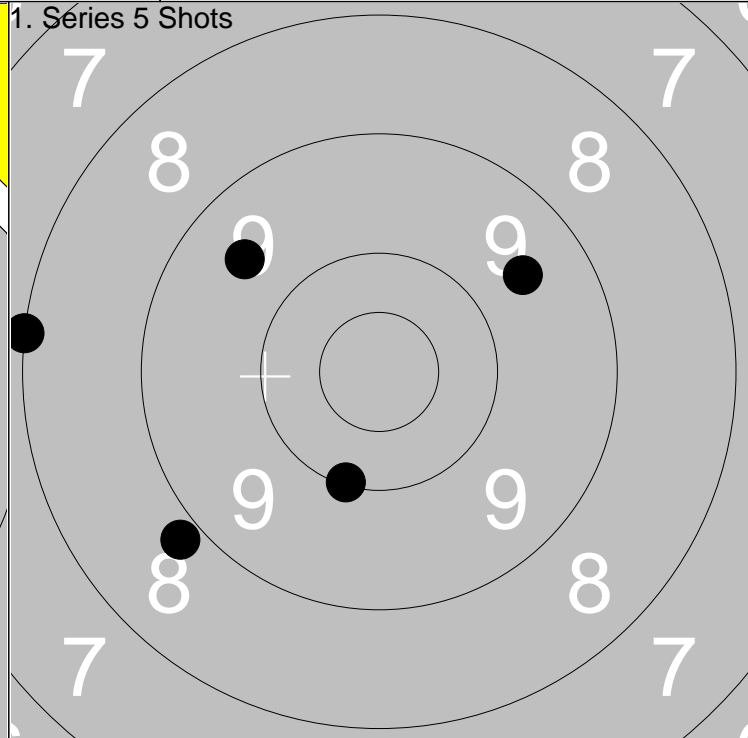
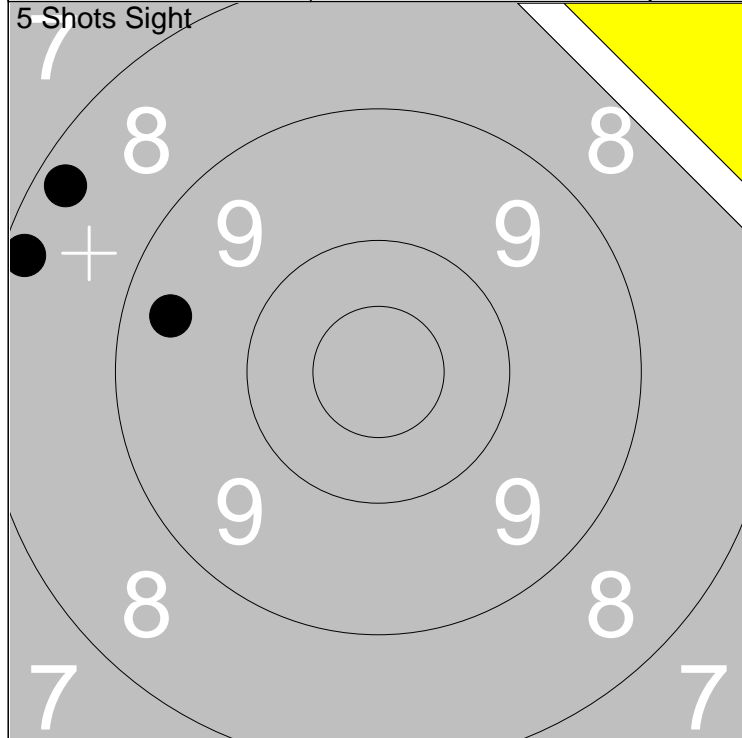

| |
|--------------------|
| 1: 8.3 ↖ |
| 2: 9.4 ↖ |
| 3: 8.2 ↖ |
| Series 25.0 |
| Total 0.0 |

| |
|--------------------|
| 1: 9.6 ↗ |
| 2: 9.6 ↖ |
| 3: 8.0 ← |
| 4: 10.1 ↓ |
| 5: 8.8 ↙ |
| Series 44.0 |
| Total 44.0 |

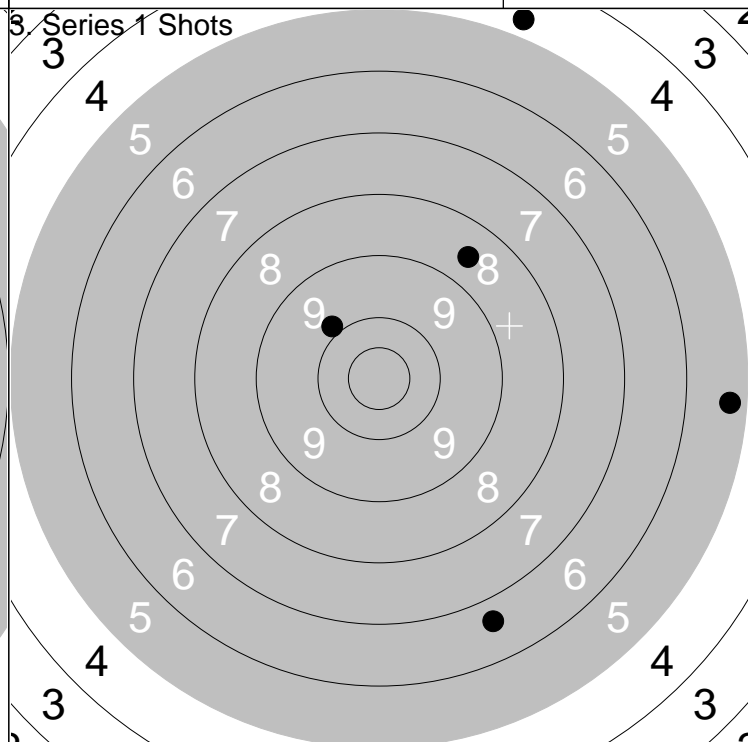
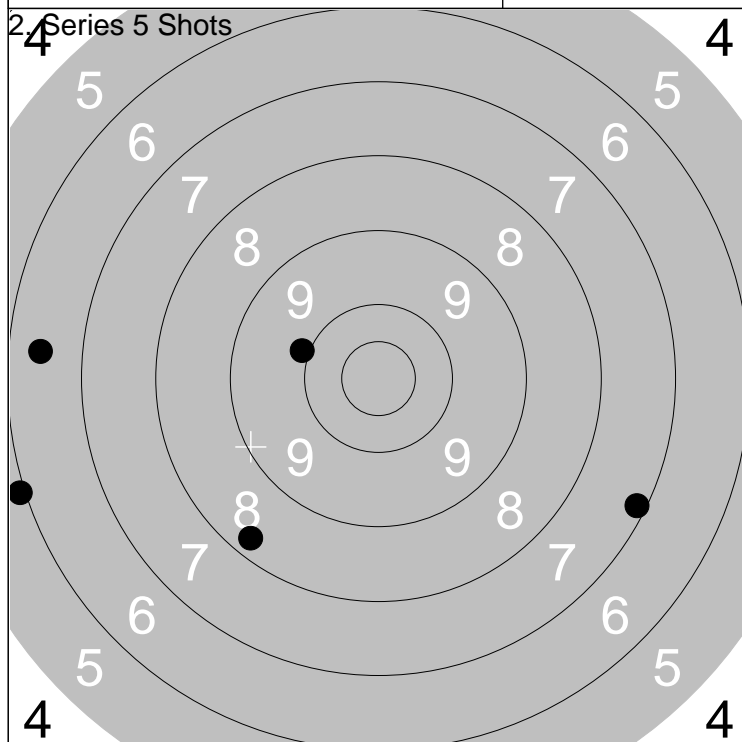

| |
|--------------------|
| 1: 9.9 ↖ |
| 2: 8.3 ↙ |
| 3: 7.2 ↗ |
| 4: 6.5 ← |
| 5: 6.0 ↖ |
| Series 36.0 |
| Total 80.0 |

| |
|--------------------|
| 1: 6.7 ↓ |
| 2: 9.9 ↖ |
| 3: 8.6 ↗ |
| 4: 5.3 → |
| 5: 4.7 ↗ |
| Series 32.0 |
| Total 112.0 |

| | | | |
|-------------------|------------------|---------------------|--|
| Relay 3 | Lane 4 | S-O Berglund | |
|-------------------|------------------|---------------------|--|

| | | |
|------|------|---|
| 300m | Umeå | H |
|------|------|---|

| | | |
|------------|-----------------------------|-----------------|
| 2013-07-27 | Postens Riksmästerskap 2013 | Ramselefors SKF |
|------------|-----------------------------|-----------------|

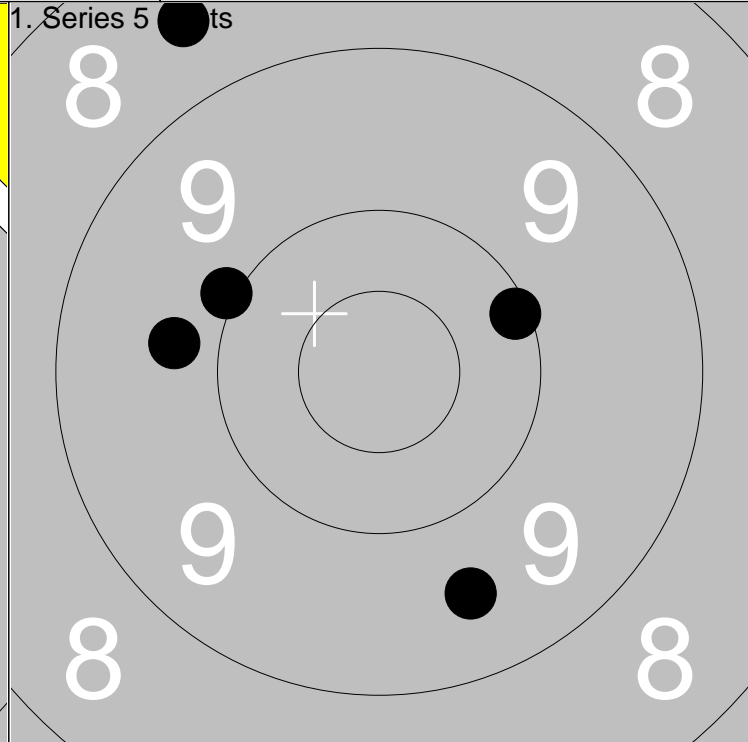
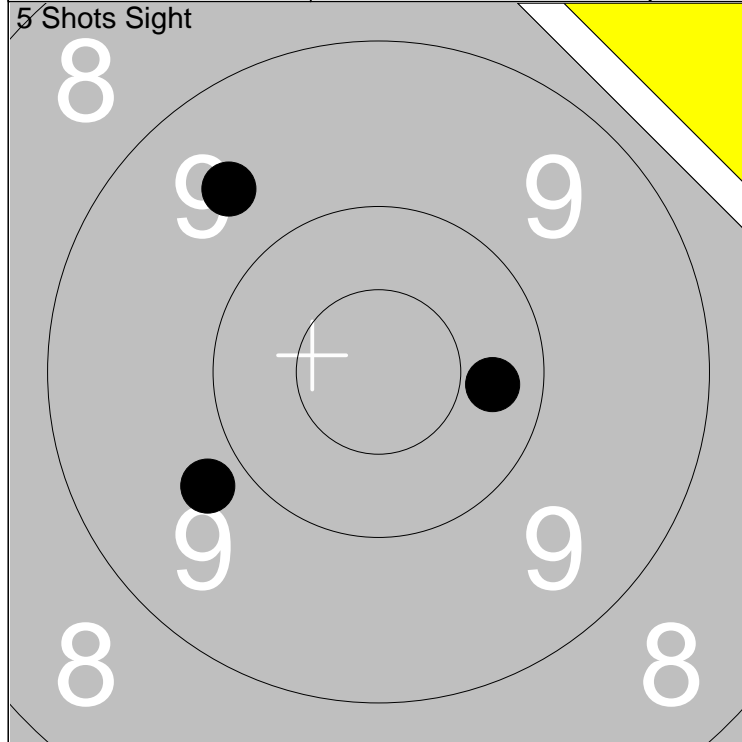

| |
|--------------------|
| 1: 9.6 ↗ |
| 2: 10.3 → |
| 3: 9.8 ↙ |
| Series 28.0 |
| Total 0.0 |

| |
|--------------------|
| 1: 10.1 → |
| 2: 9.5 ↘ |
| 3: 10.0 ↖ |
| 4: 8.5 ↗ |
| 5: 9.8 ← |
| Series 46.0 |
| Total 46.0 |

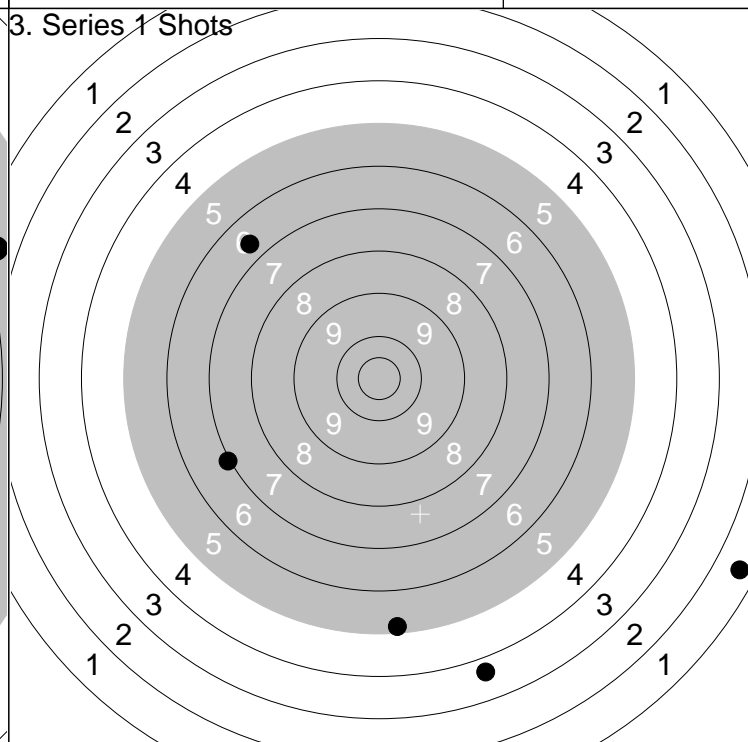
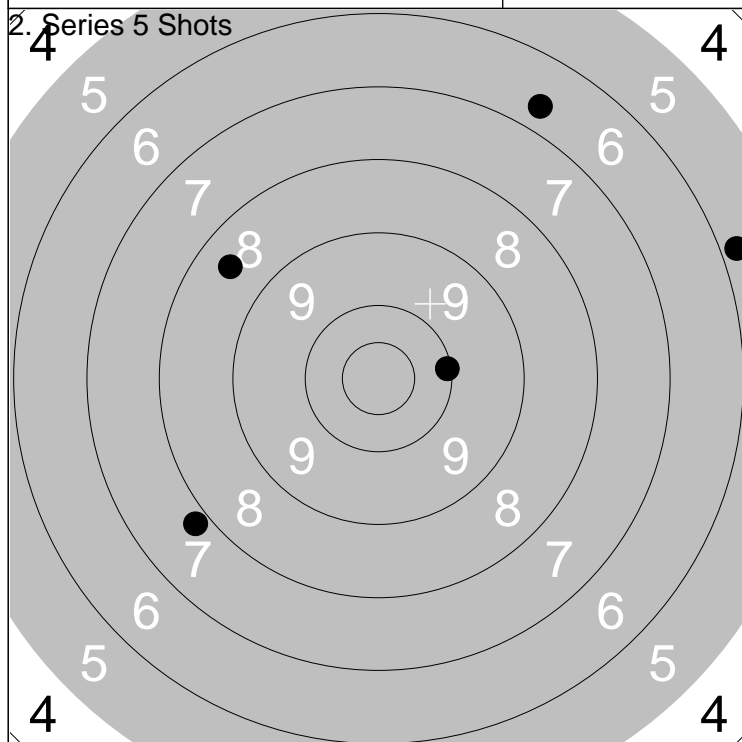

| |
|--------------------|
| 1: 10.1 → |
| 2: 8.5 ↖ |
| 3: 6.7 ↗ |
| 4: 7.8 ↙ |
| 5: 5.8 → |
| Series 36.0 |
| Total 82.0 |

| |
|--------------------|
| 1: 6.6 ↖ |
| 2: 7.0 ↙ |
| 3: 3.7 ↘ |
| 4: 1.4 → |
| 5: 5.2 ↓ |
| Series 22.0 |
| Total 104.0 |

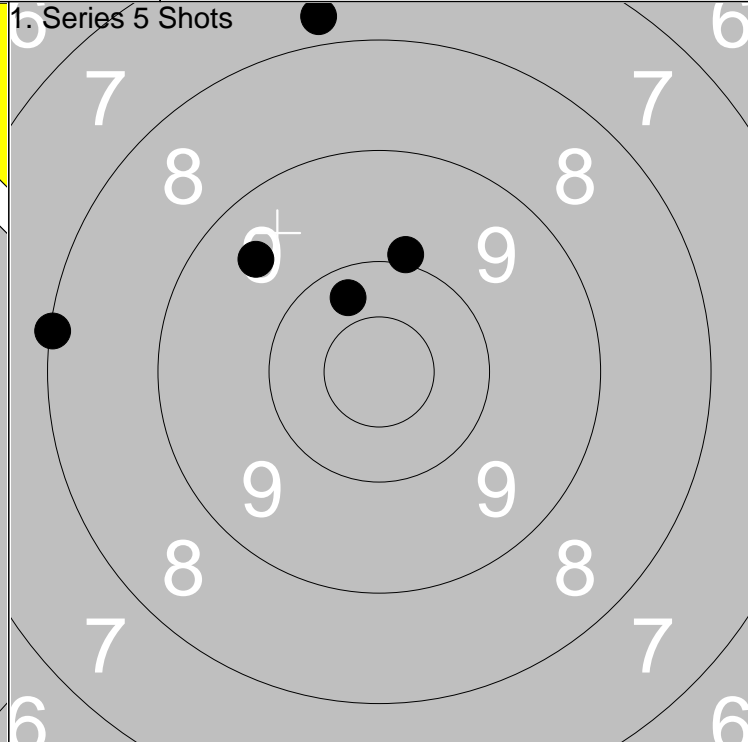
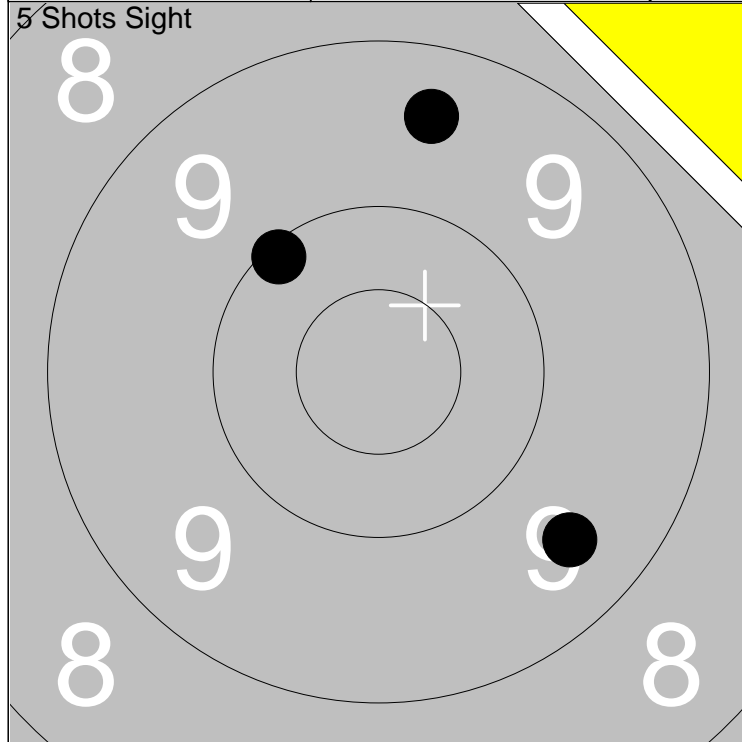

| | |
|-----------|-------------|
| 1: 10.1 ↗ | Series 28.0 |
| 2: 9.5 ↑ | |
| 3: 9.5 ↘ | |
| Total 0.0 | |

| | |
|------------|-------------|
| 1: 10.3 ↗ | Series 43.0 |
| 2: 7.8 ↑ | |
| 3: 9.9 ↑ | |
| Total 43.0 | |

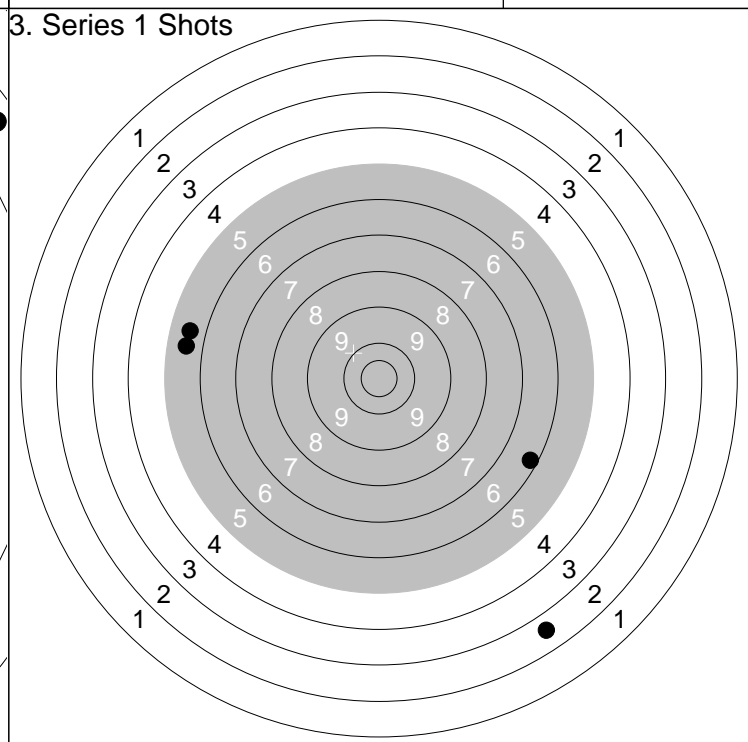
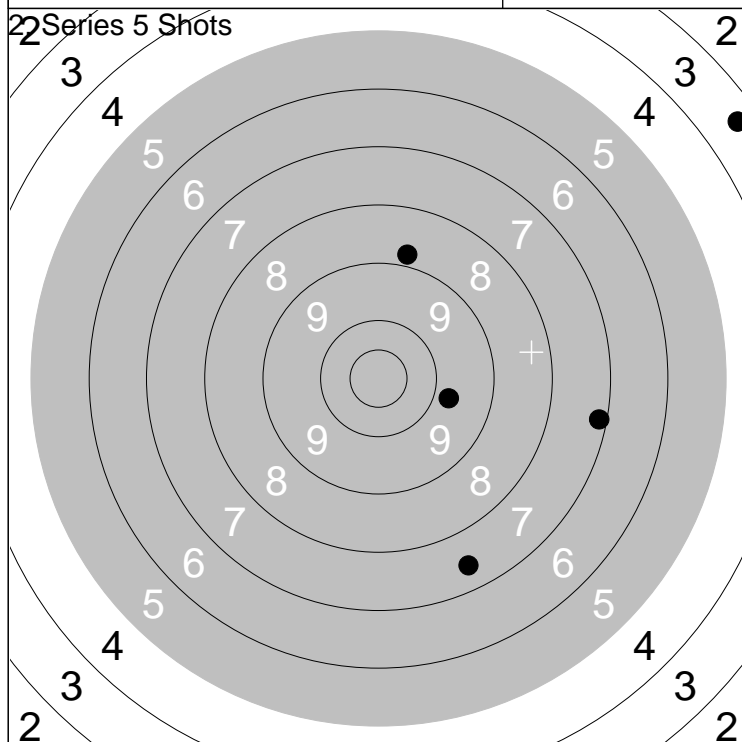

| | |
|------------|-------------|
| 1: 8.8 ↑ | Series 34.0 |
| 2: 7.5 ↘ | |
| 3: 7.2 → | |
| Total 77.0 | |

| | |
|------------|-------------|
| 1: 5.6 ← | Series 18.0 |
| 2: 6.2 ↘ | |
| 3: 5.6 ← | |
| Total 95.0 | |

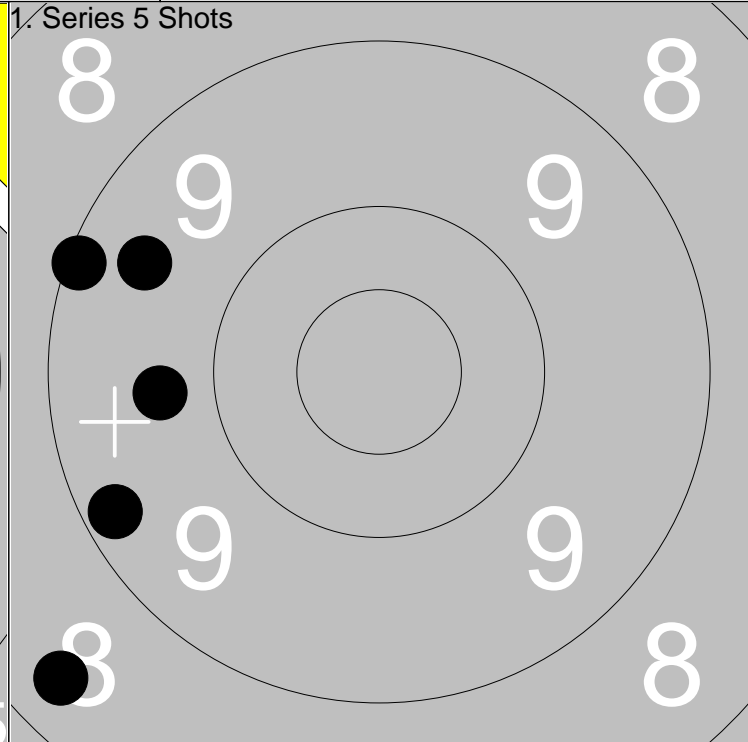
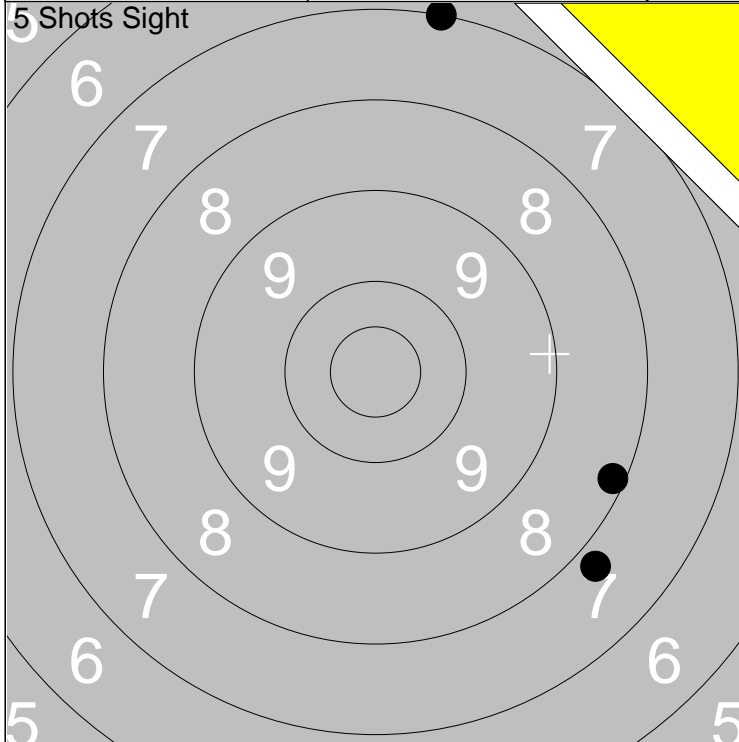

| | | |
|----------|--------|------|
| 1: 7.0 ↑ | Series | 22.0 |
| 2: 8.2 → | | |
| 3: 7.8 ↘ | | |
| Total | | 0.0 |

| | | |
|----------|--------|------|
| 1: 9.7 ← | Series | 44.0 |
| 2: 8.4 ↘ | | |
| 3: 9.5 ← | | |
| Total | | 44.0 |

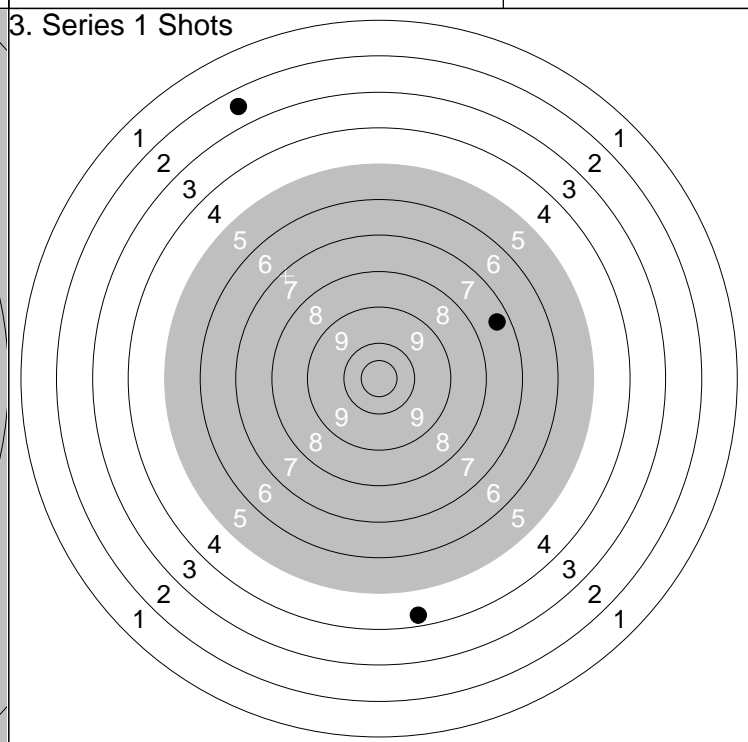
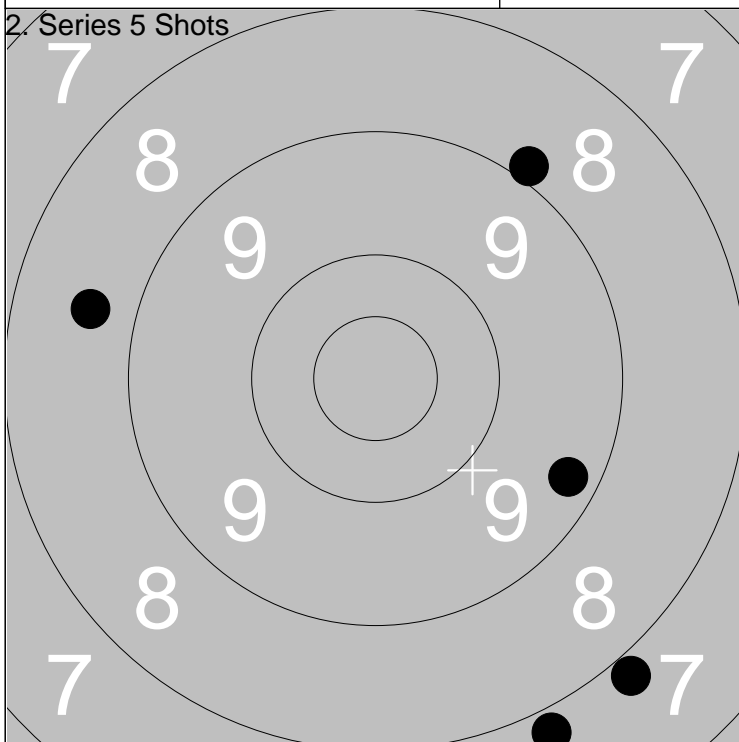

| | | |
|----------|--------|------|
| 1: 7.8 ↘ | Series | 39.0 |
| 2: 8.7 ← | | |
| 3: 7.9 ↘ | | |
| Total | | 83.0 |

| | | |
|----------|--------|------|
| 1: 7.4 → | Series | 13.0 |
| 2: 0.0 | | |
| 3: 0.0 ← | | |
| Total | | 96.0 |

Relay **3** Lane **7** **Bo Andersson**

300m Nässjö H

2013-07-27 Postens Riksmästerskap 2013 Ramselefors SKF

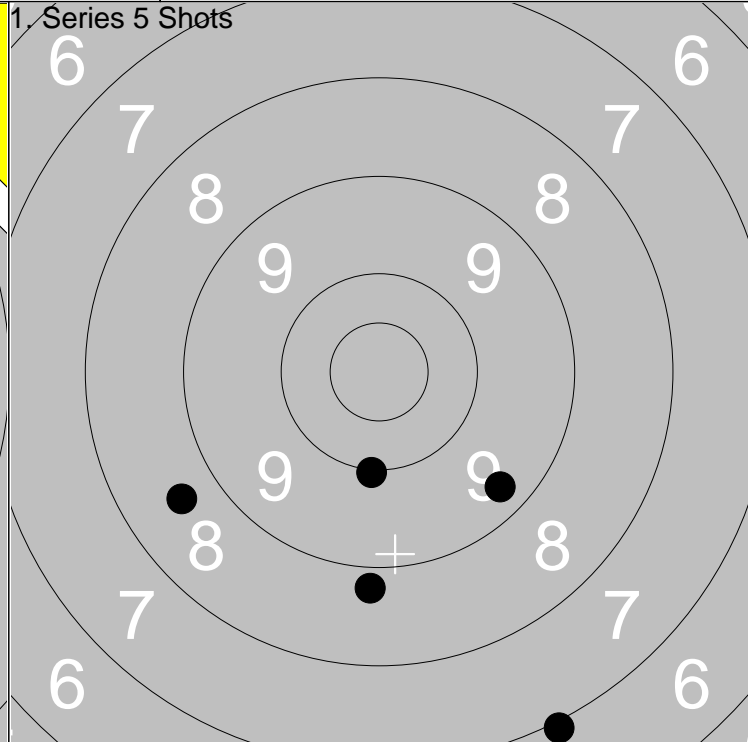
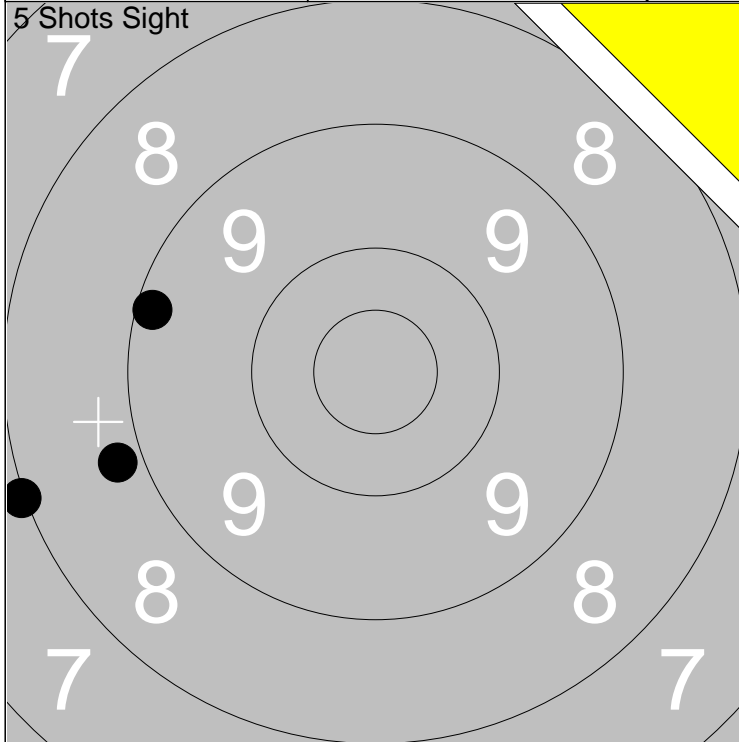

| | |
|---------------|-------------|
| 1: 8.0 | ← |
| 2: 9.2 | ← |
| 3: 8.8 | ← |
| Series | 25.0 |
| Total | 0.0 |

| | |
|---------------|-------------|
| 1: 10.0 | ↓ |
| 2: 9.3 | ↘ |
| 3: 7.0 | ↓ |
| 4: 8.8 | ↓ |
| 5: 8.6 | ↙ |
| Series | 42.0 |
| Total | 42.0 |

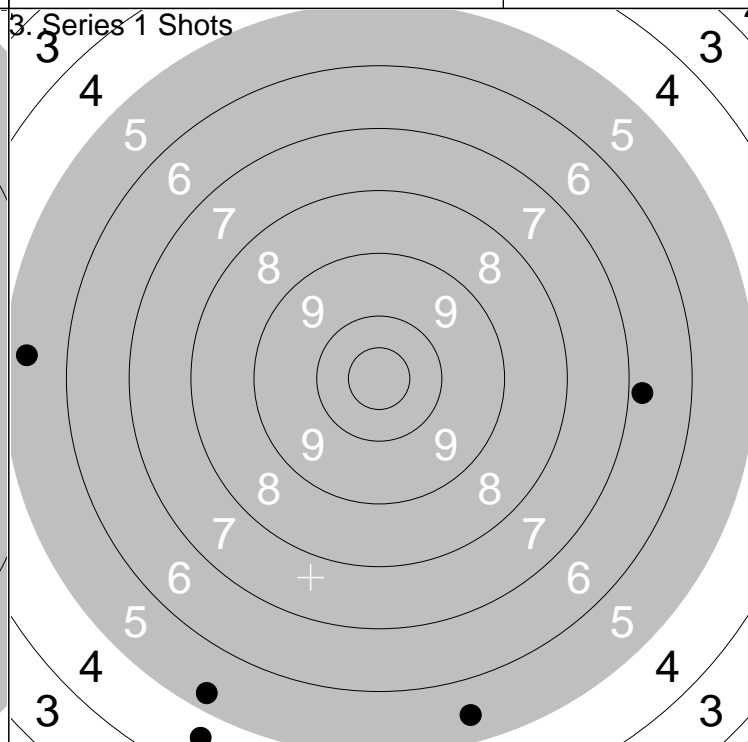
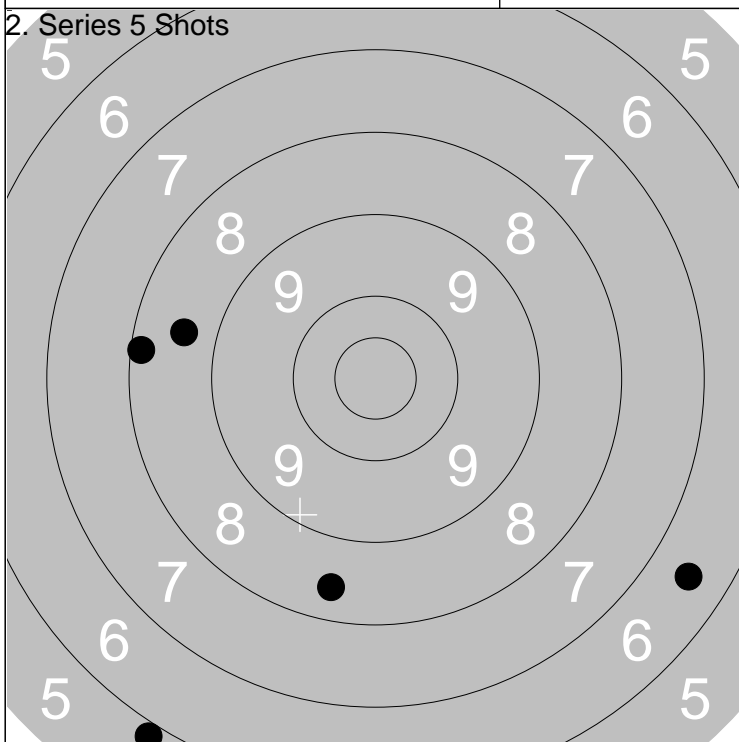

| | |
|---------------|-------------|
| 1: 6.5 | ↘ |
| 2: 8.4 | ↓ |
| 3: 8.6 | ← |
| 4: 5.9 | ↘ |
| 5: 8.2 | ← |
| Series | 35.0 |
| Total | 77.0 |

| | |
|---------------|--------------|
| 1: 6.8 | → |
| 2: 5.3 | ↘ |
| 3: 4.6 | ↘ |
| 4: 5.5 | ↘ |
| 5: 5.4 | ← |
| Series | 25.0 |
| Total | 102.0 |