

1: 9.6 ↗	6: 10.2 ↓			1: 9.3 ←					
2: 9.6 ↘	7: *10.4 ↗	Serie	77.0	2: 9.2 ←				Serie	47.0
3: *10.7 ↓	8: 9.5 ↓			3: 9.3 ↓					
4: *10.7 ↖		Total	192.0	4: 10.1 ↓				Total	239.0
5: 10.0 →				5: *10.6 ↓					

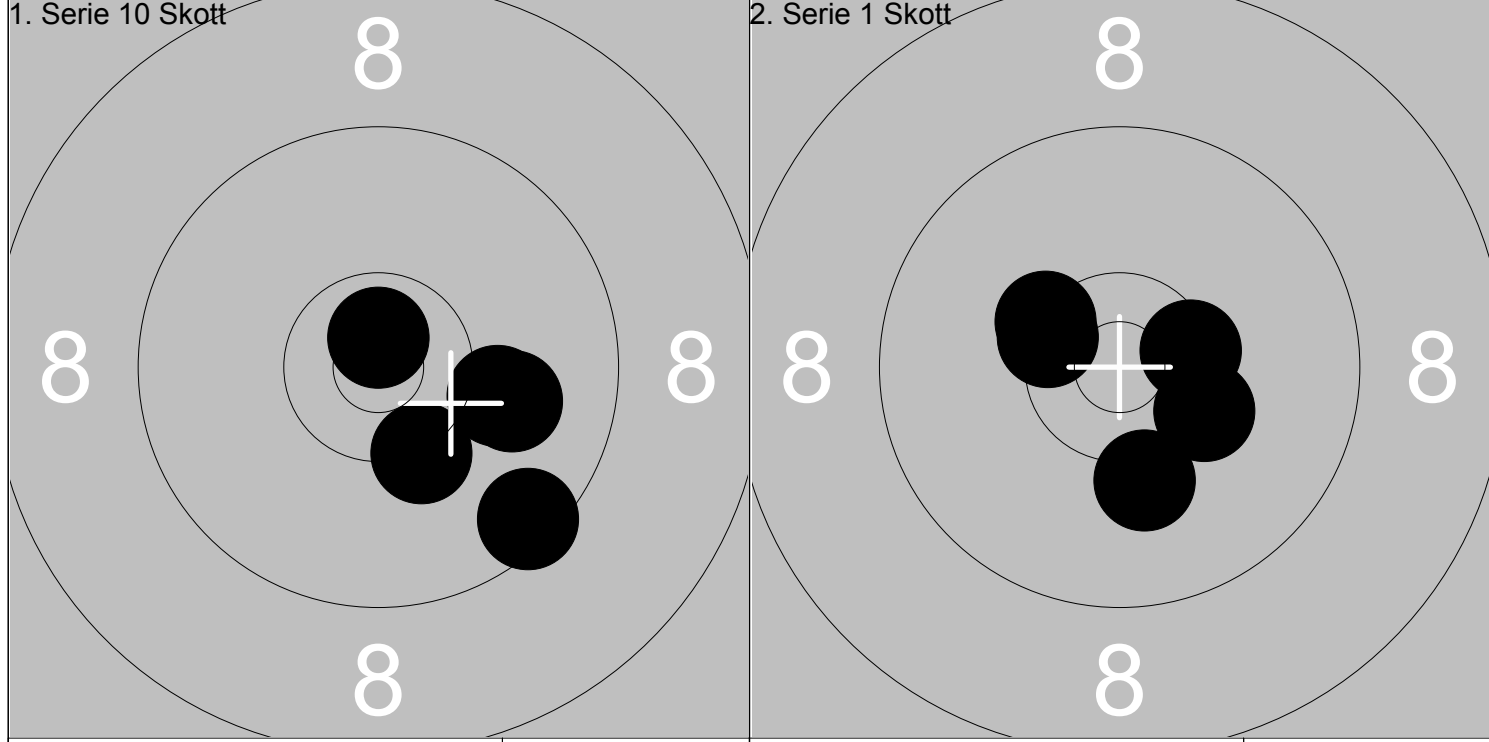
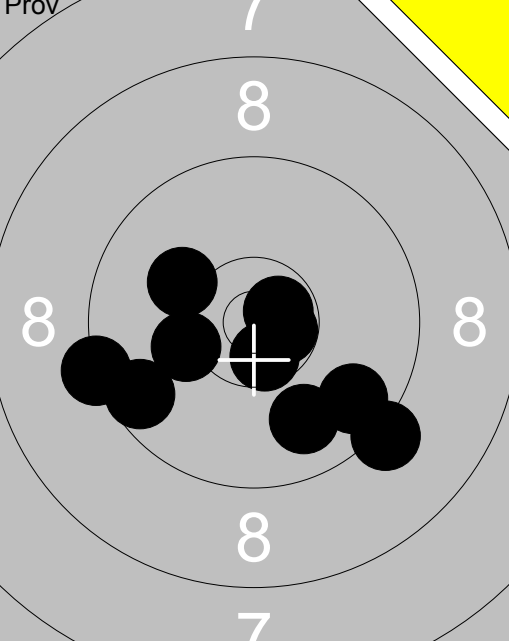
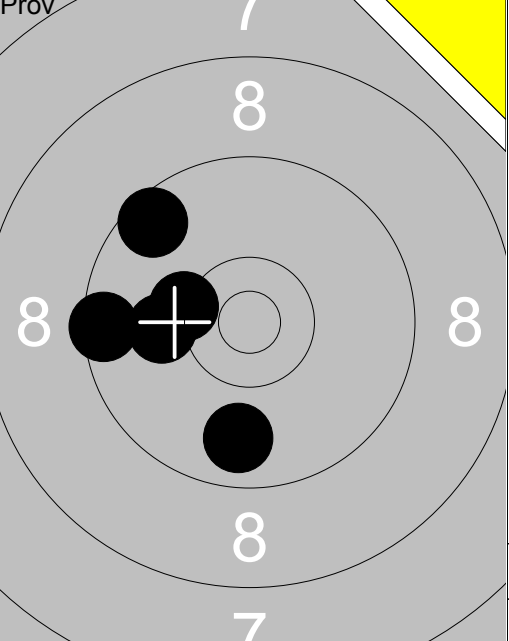
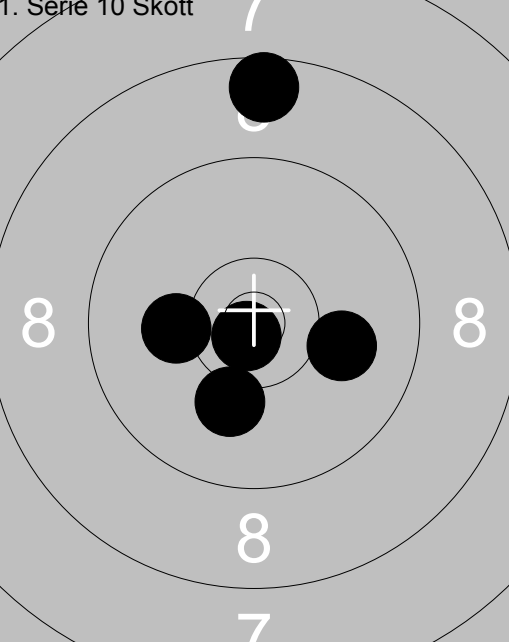
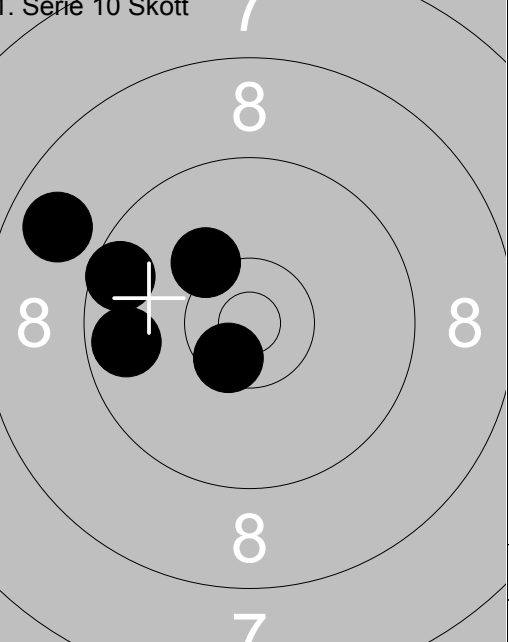

6: 10.1 →				1: *10.4 ↗					
7: *10.7 ↑		Serie	49.0	2: *10.3 ↗				Serie	50.0
8: *10.3 ↓				3: *10.4 ↖					
9: 9.5 ↓		Total	288.0	4: 10.2 ↓				Total	338.0
10: 10.0 →				5: *10.4 ↖					

	<p>1: 9.2 ↘</p> <p>2: *10.6 ↘</p> <p>3: 10.2 ←</p> <p>4: 9.9 ↘</p> <p>5: *10.6 →</p> <p>6: 10.1 ↖</p> <p>7: 9.3 ←</p> <p>8: 9.7 ↘</p> <p>9: *10.7 →</p> <p>10: 9.6 ←</p>	<p>Prov</p> 	<p>11: 9.6 ↖</p> <p>12: 9.5 ←</p> <p>13: 10.3 ←</p> <p>14: 10.1 ←</p> <p>15: 9.8 ↓</p>
Serie 95.0		Serie 47.0	
Total 189.0		Total 189.0	

<p>1. Serie 10 Skott</p> 	<p>1: *10.8 ↘</p> <p>2: 10.1 ↘</p> <p>3: 10.2 ←</p> <p>4: 10.0 →</p> <p>5: 8.6 ↑</p>	<p>1. Serie 10 Skott</p> 	<p>6: 9.7 ←</p> <p>7: *10.5 ↘</p> <p>8: 8.8 ↖</p> <p>9: 9.6 ←</p> <p>10: 10.2 ↖</p>
Serie 48.0		Serie 46.0	
Total 237.0		Total 283.0	

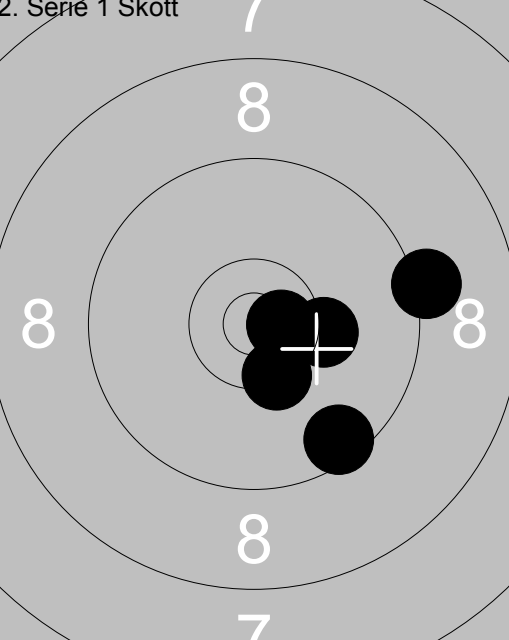
<p>2. Serie 1 Skott</p> 	<p>1: *10.7 →</p> <p>2: 9.5 ↘</p> <p>3: *10.4 ↘</p> <p>4: 9.2 →</p> <p>5: 10.3 →</p>		
Serie 48.0			
Total 331.0			

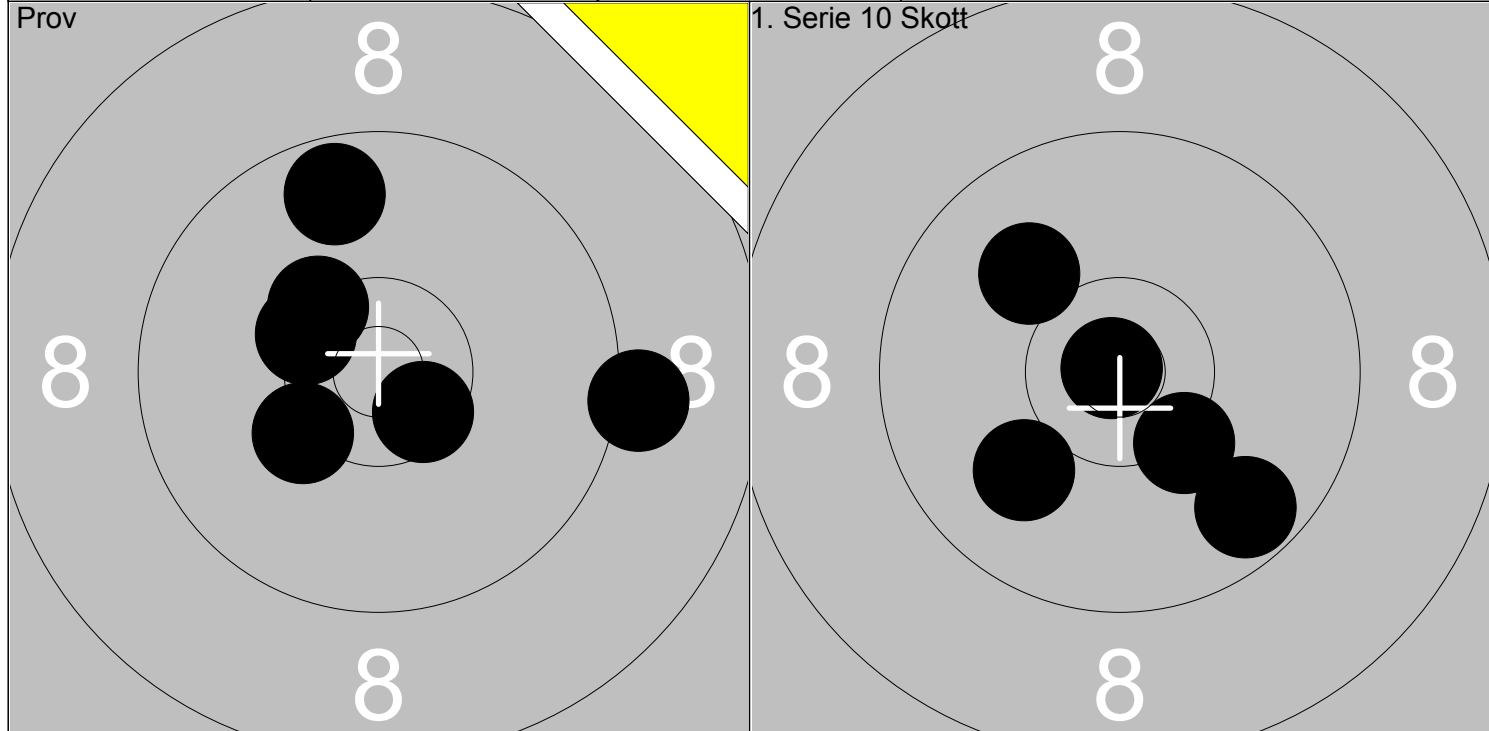

1: 9.7 ↑	6: *10.3 ↖						
2: 10.3 ↙		Serie	58.0	1: 10.0 ↙		Serie	49.0
3: 9.2 →				2: 9.7 ↘			
4: *10.4 ↖		Total	188.0	3: 10.0 ↗		Total	237.0
5: *10.5 ↘				4: *10.9 ↖			
				5: *10.3 ↘			

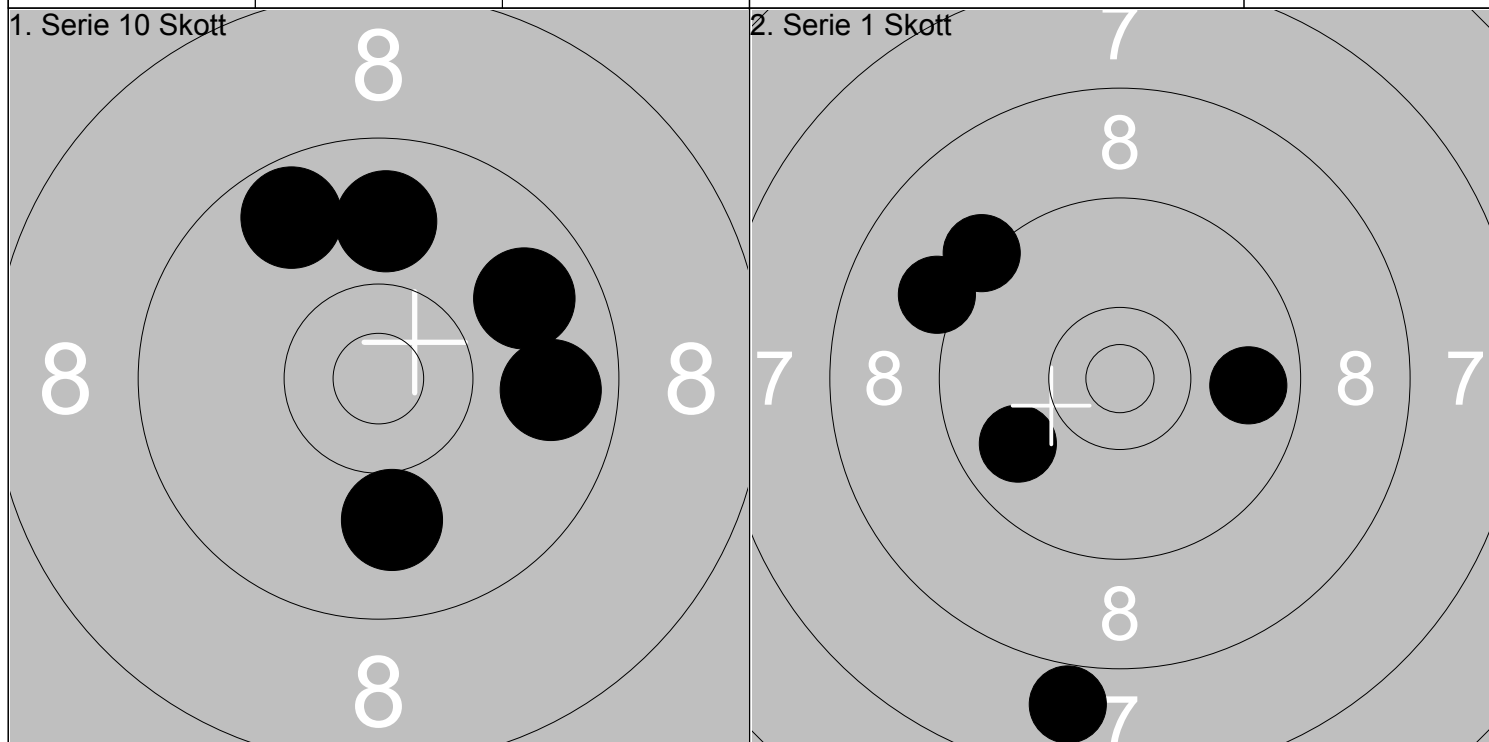

6: 10.0 ↓							
7: 9.8 ↗		Serie	46.0	1: 9.2 ↖		Serie	43.0
8: 9.7 ↖				2: 9.8 ↙			
9: 9.9 ↑		Total	283.0	3: 9.8 →		Total	326.0
10: 9.8 →				4: 9.1 ↖			
				5: 7.9 ↓			

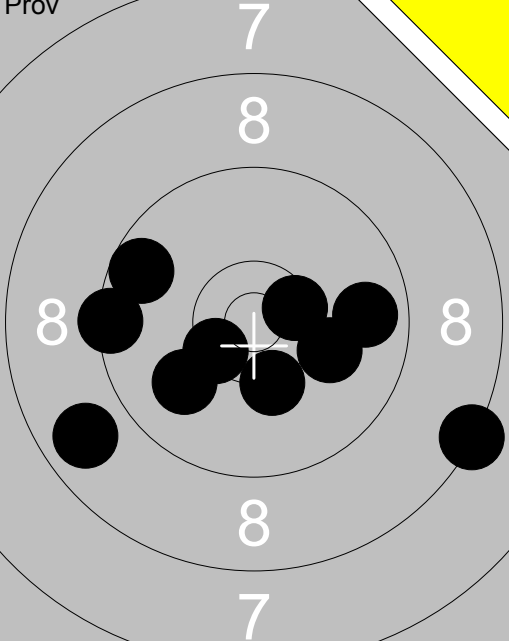
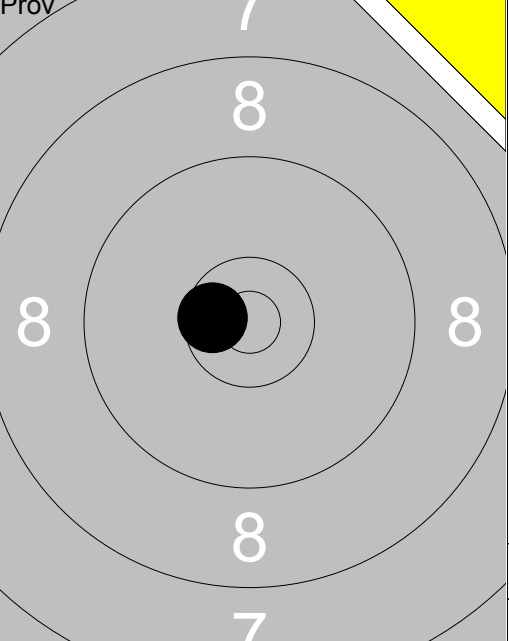
Prov 	1: 9.8 → 2: *10.4 ↙ 3: 10.3 ↓ 4: 8.8 ← 5: *10.5 → 6: 8.3 → 7: 9.6 ← 8: 9.4 ← 9: 10.1 → 10: 10.0 ↙	Prov 	11: *10.6 ↙
Serie 93.0		Serie 10.0	
Total 186.0		Total 186.0	

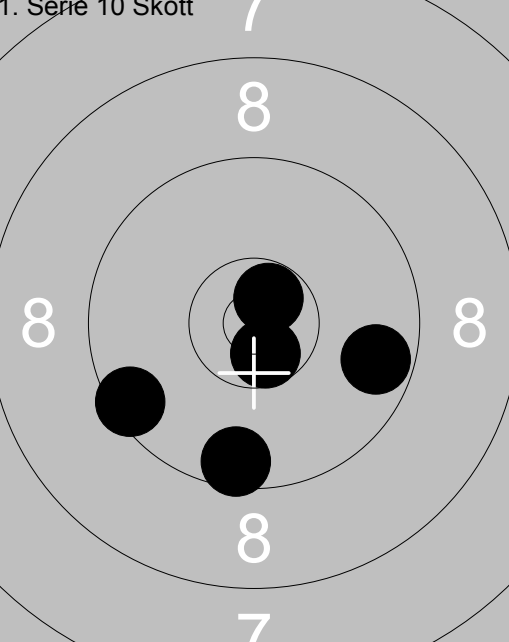
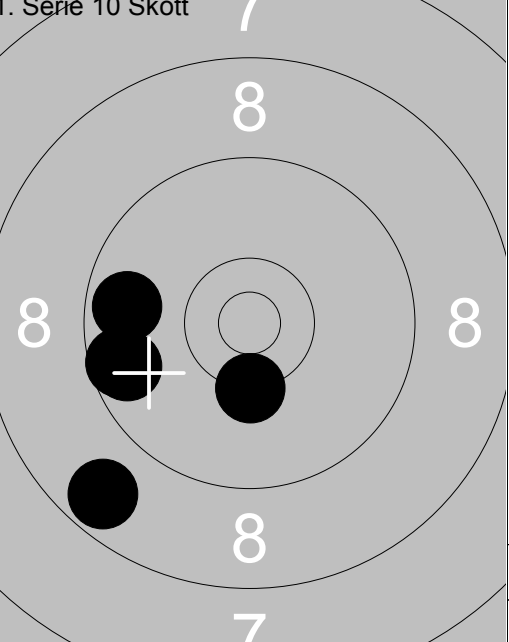
1. Serie 10 Skott 	1: *10.7 ↗ 2: 9.5 ← 3: 9.7 → 4: *10.6 ↓ 5: 9.6 ↓	1. Serie 10 Skott 	6: 9.6 ← 7: *10.3 ↓ 8: 9.7 ← 9: 9.7 ← 10: 8.7 ↙
Serie 47.0		Serie 45.0	
Total 233.0		Total 278.0	

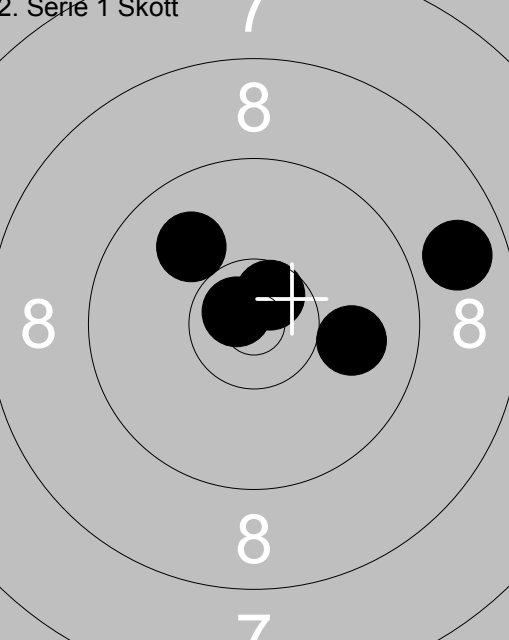
2. Serie 1 Skott 	1: *10.6 ↗ 2: 10.0 → 3: *10.7 ↗ 4: 8.8 → 5: 10.0 ↖		
Serie 48.0			
Total 326.0			

	Prov 1: 10.2 → 2: 9.2 ↗ 3: 8.0 ↗ 4: 9.0 ↗ 5: 8.2 ← 6: 9.5 ← 7: 8.3 ← 8: 9.0 ← 9: 10.0 ↑ 10: 9.1 ↖ <hr/> Serie 89.0 <hr/> Total 179.0		Prov 11: *10.4 → 12: 9.0 ↖ 13: 9.7 ↖ 14: 10.1 ←	
		Serie 38.0		
		Total 179.0		

1. Serie 10 Skott 	1: *10.4 ↘ 2: 9.9 ← 3: 8.7 ↑ 4: 9.2 ↗ 5: 10.2 ↖	1. Serie 10 Skott 		
		Serie 46.0		
		Total 225.0		
		Serie 46.0		
		Total 271.0		

2. Serie 1 Skott 	1: 9.4 → 2: *10.3 ↘ 3: 9.6 ↗ 4: 9.6 ↗ 5: 9.9 →			
		Serie 46.0		
		Total 317.0		

	<p>1: 8.8 ↑</p> <p>2: 9.6 ↗</p> <p>3: *10.3 ←</p> <p>4: 10.0 ↓</p> <p>5: *10.8 →</p> <p>6: 10.2 →</p> <p>7: 9.7 ↓</p> <p>8: 9.9 →</p> <p>9: 10.1 ↑</p> <p>10: 9.6 ↖</p>		<p>11: 8.7 ↖</p> <p>12: 9.0 ↖</p> <p>13: 9.9 ↖</p> <p>14: 10.1 ↑</p>
Serie 94.0		Serie 36.0	
Total 188.0		Total 188.0	

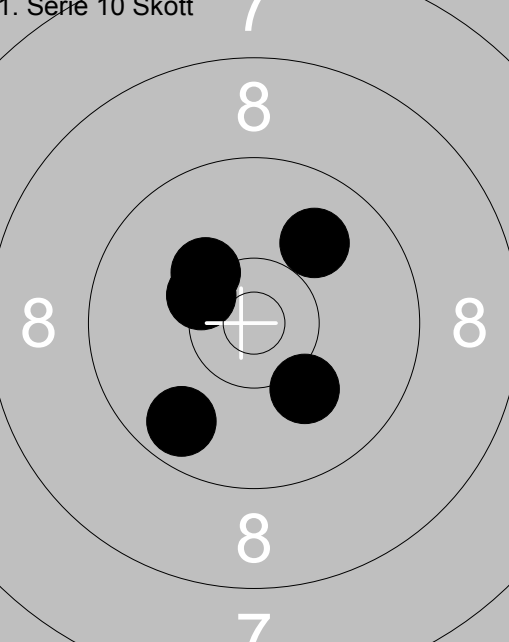
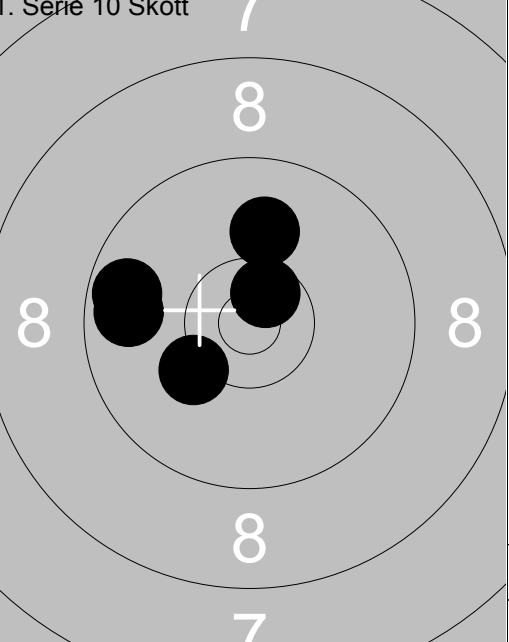
<p>1. Serie 10 Skott</p> 	<p>1: 9.9 ↗</p> <p>2: 10.3 ↖</p> <p>3: 10.1 ↓</p> <p>4: 9.7 ↓</p> <p>5: *10.3 ←</p>	<p>1. Serie 10 Skott</p> 	<p>6: 9.7 ←</p> <p>7: 9.7 ←</p> <p>8: *10.6 ↗</p> <p>9: 10.0 ↑</p> <p>10: 10.2 ↙</p>
Serie 48.0		Serie 48.0	
Total 236.0		Total 284.0	

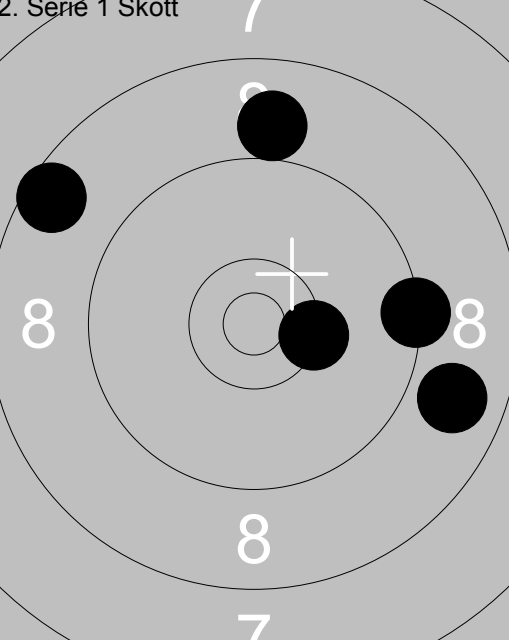
<p>2. Serie 1 Skott</p> 	<p>1: 8.6 ↖</p> <p>2: 9.0 ↑</p> <p>3: 9.3 →</p> <p>4: 8.8 →</p> <p>5: *10.3 →</p>		
Serie 44.0			
Total 328.0			

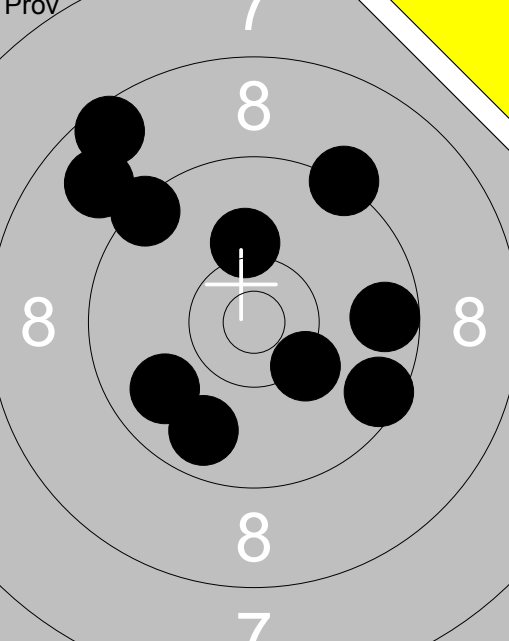
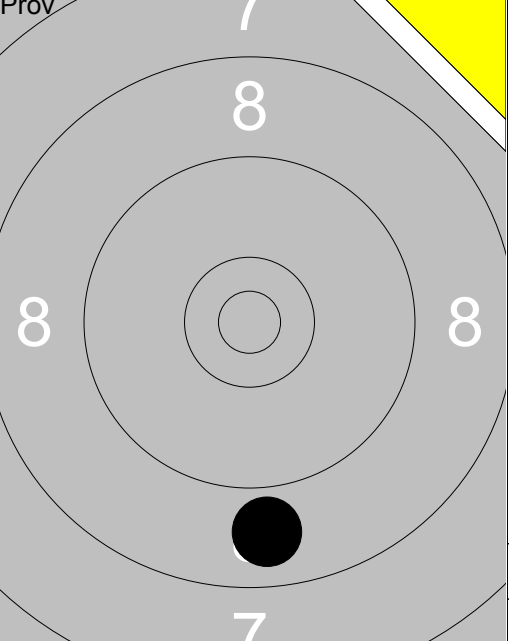
 <p style="font-size: small;">Prov</p>	<p>1: 9.5 →</p> <p>2: 9.8 ↓</p> <p>3: 10.3 ↘</p> <p>4: 9.3 ↗</p> <p>5: 9.8 ↙</p> <p>6: 9.4 ↖</p> <p>7: 9.6 →</p> <p>8: 10.2 ↑</p> <p>9: 8.9 ↖</p> <p>10: 8.6 ↖</p>	 <p style="font-size: small;">Prov</p>	<p>11: 8.9 ↓</p>
Serie	90.0	Serie	8.0
Total	184.0	Total	184.0

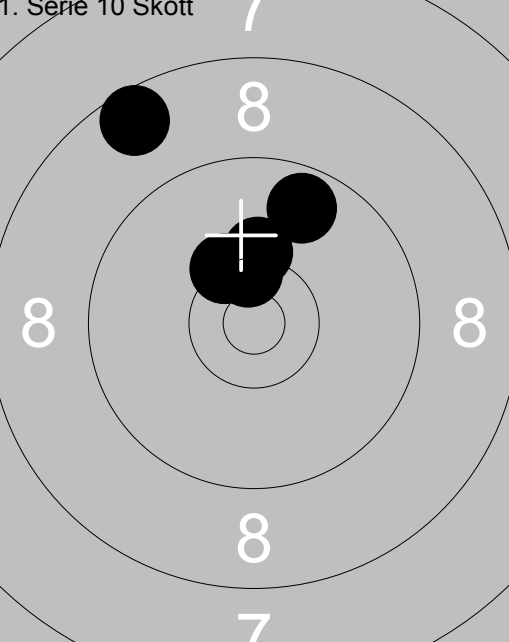
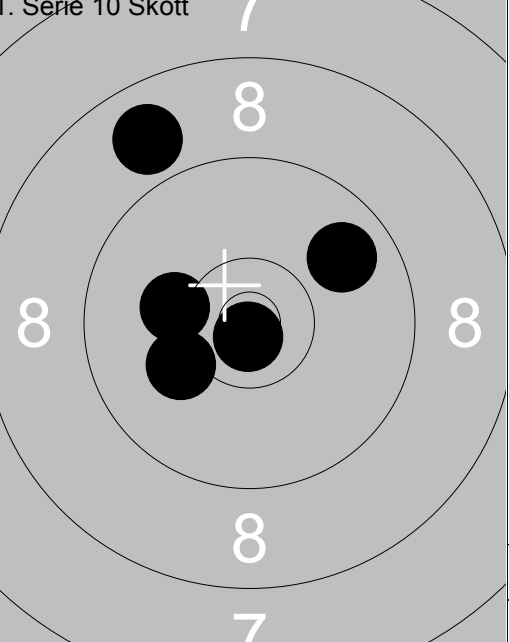
<p style="font-size: small;">1. Serie 10 Skott</p> 	<p>1: 9.7 ↗</p> <p>2: *10.3 ↘</p> <p>3: *10.4 ↑</p> <p>4: 10.2 ↑</p> <p>5: 8.6 ↖</p>	<p style="font-size: small;">1. Serie 10 Skott</p> 	<p>6: 10.2 ↙</p> <p>7: 10.1 ↙</p> <p>8: 9.8 ↗</p> <p>9: *10.8 ↓</p> <p>10: 8.9 ↖</p>
Serie	47.0	Serie	47.0
Total	231.0	Total	278.0

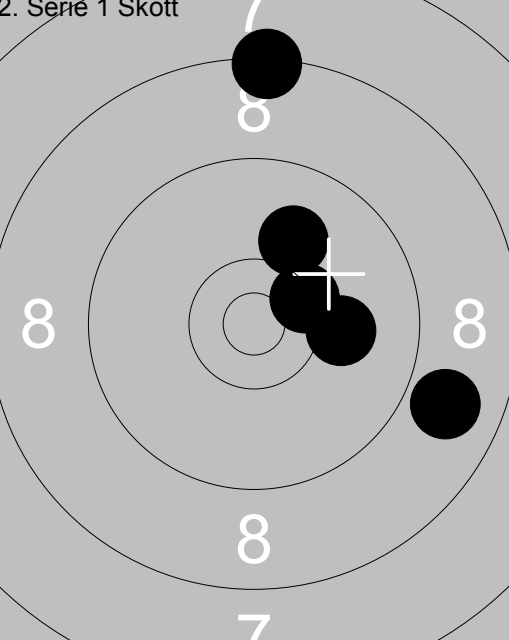
<p style="font-size: small;">2. Serie 1 Skott</p> 	<p>1: 8.4 ↑</p> <p>2: 10.0 ↗</p> <p>3: 10.1 →</p> <p>4: 8.9 →</p> <p>5: *10.4 ↗</p>		
Serie	46.0		
Total	324.0		

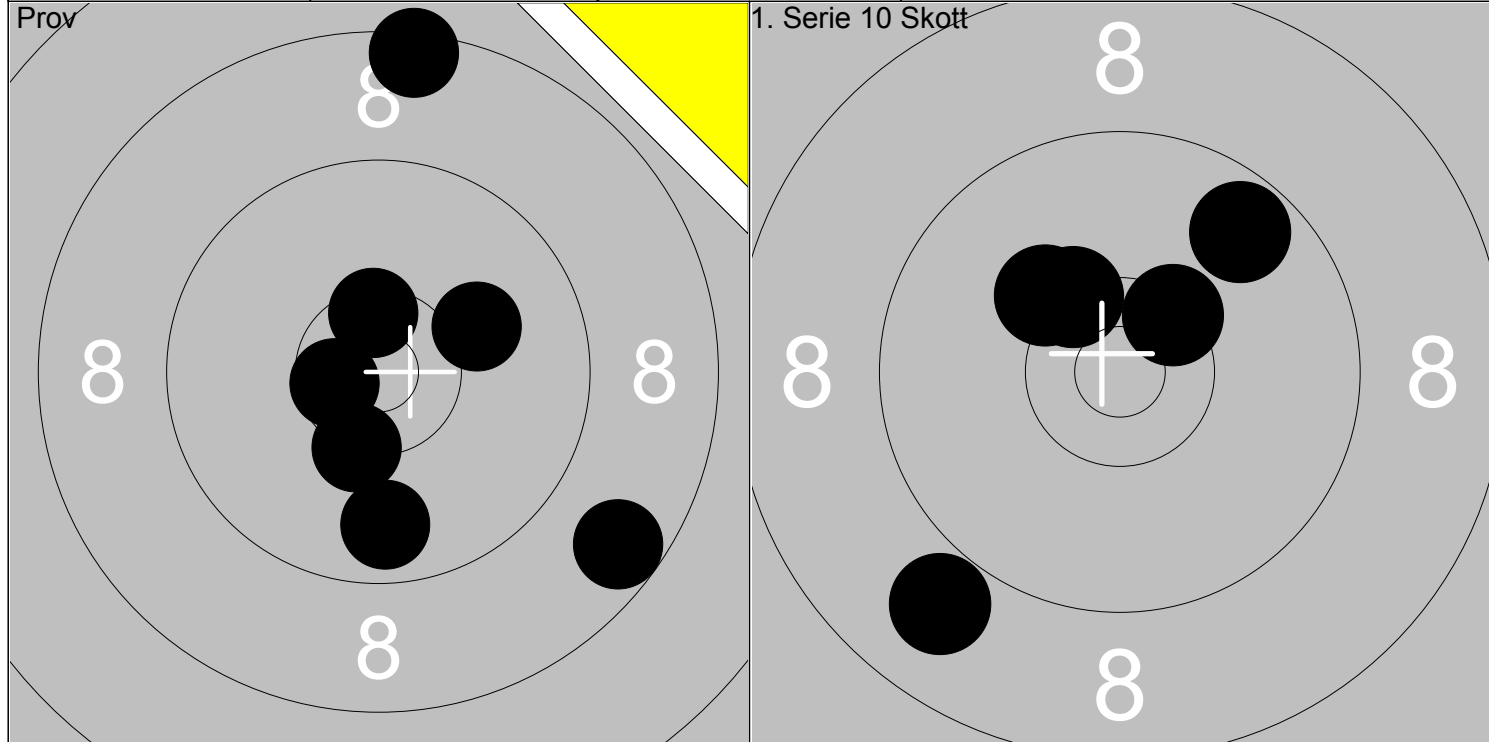

1: *10.5↑	6: *10.6←			1: 10.2↖					
2: 9.8 ↓	7: *10.3↓	Serie	65.0	2: 9.7 ↗				Serie	47.0
3: 10.1 →				3: 8.9 ↙					
4: 8.7 ↘		Total	181.0	4: *10.3↖				Total	228.0
5: 8.4 ↑				5: *10.4↗					

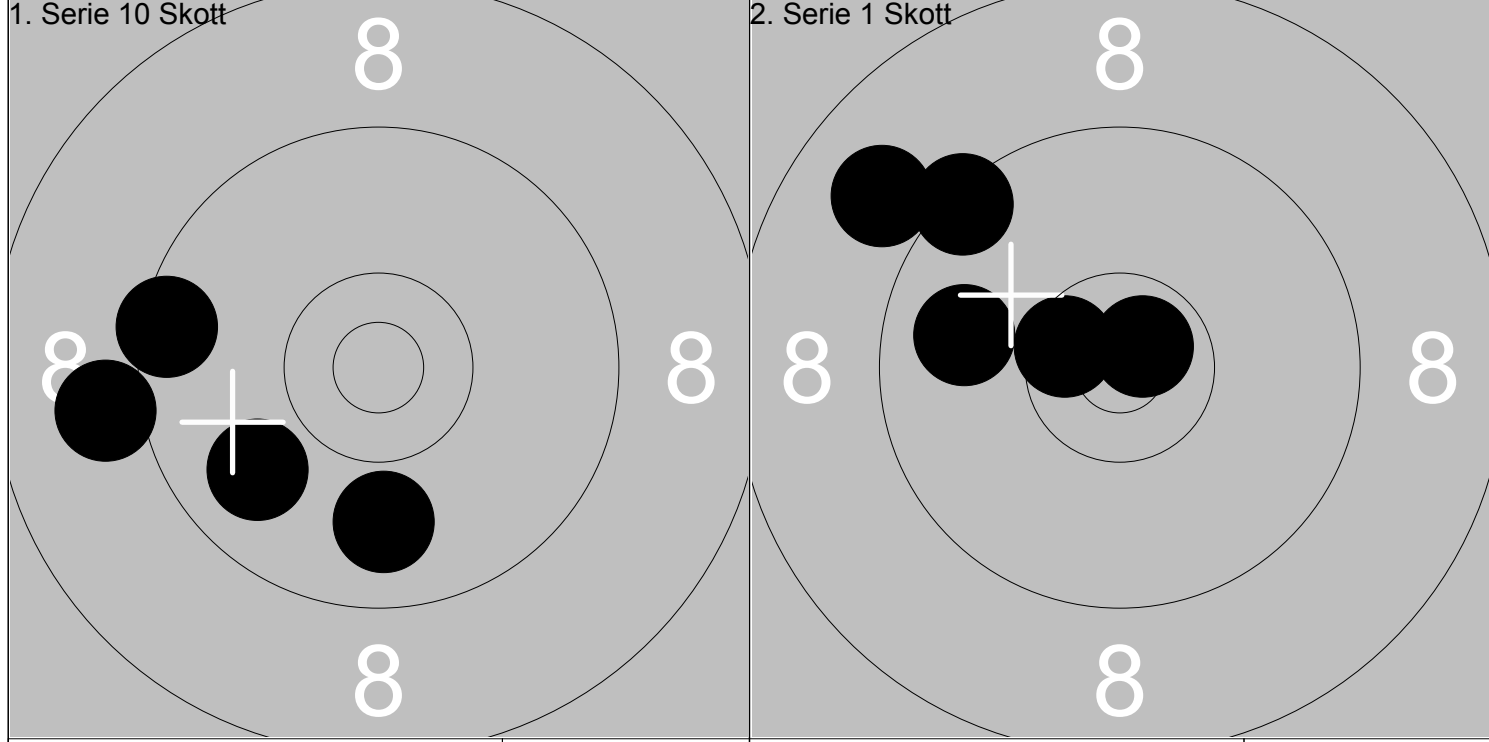

6: 9.9 ↙				1: *10.7↗					
7: 9.5 ←		Serie	36.0	2: *10.5↖				Serie	46.0
8: 9.9 ↓				3: 9.9 ←					
9: 9.1 ←		Total	264.0	4: 8.9 ↖				Total	310.0
				5: 9.4 ↖					

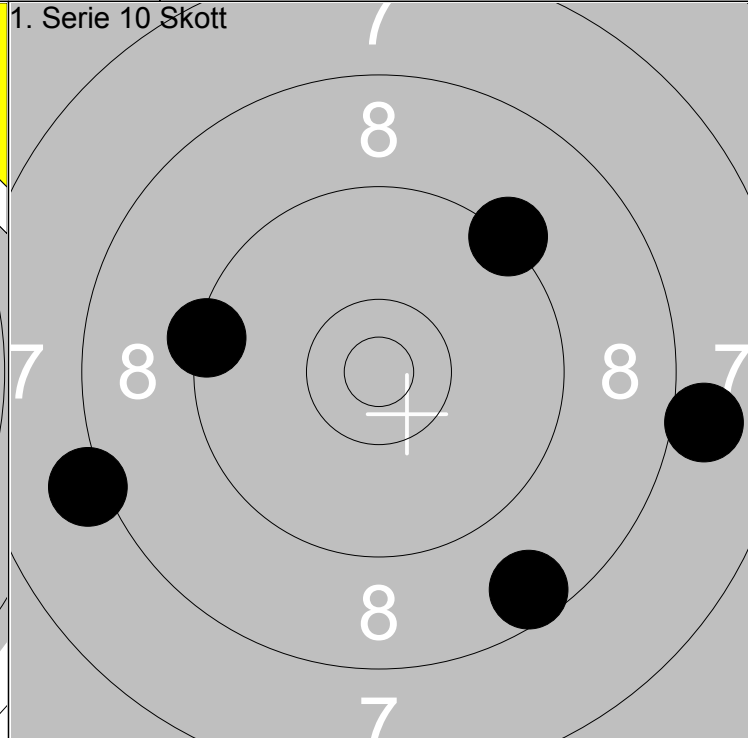
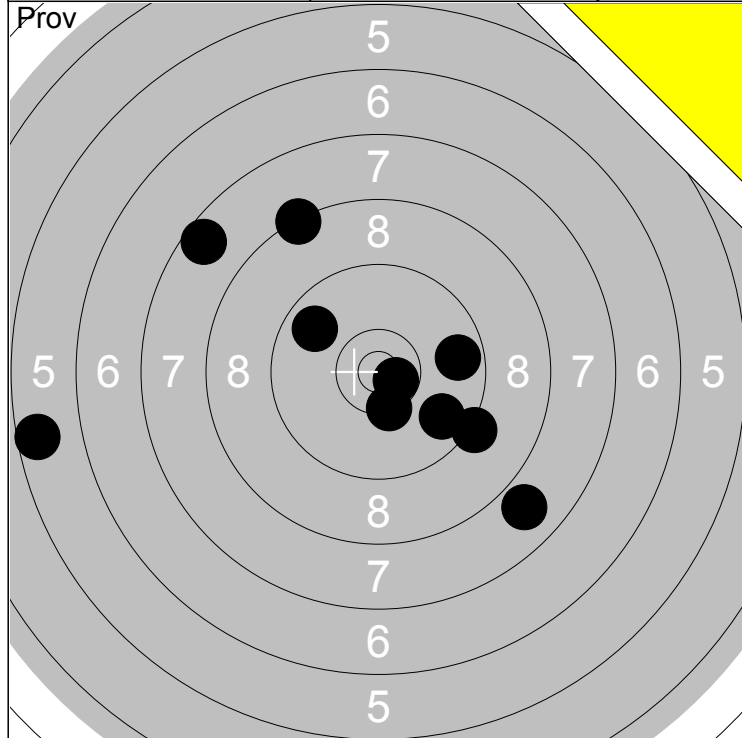

1: *10.4 ↓	6: 8.3 ↗	Serie	83.0
2: 7.9 ↓	7: 9.8 ↓		
3: 9.7 →	8: *10.7 →	Total	180.0
4: 9.2 ↓	9: 7.6 ↗		
5: 5.6 ←	10: 9.8 ↗		

1: 9.4 ←	Serie	42.0
2: 8.2 ←		
3: 8.0 →	Total	222.0
4: 9.3 ↗		
5: 8.6 ↓		

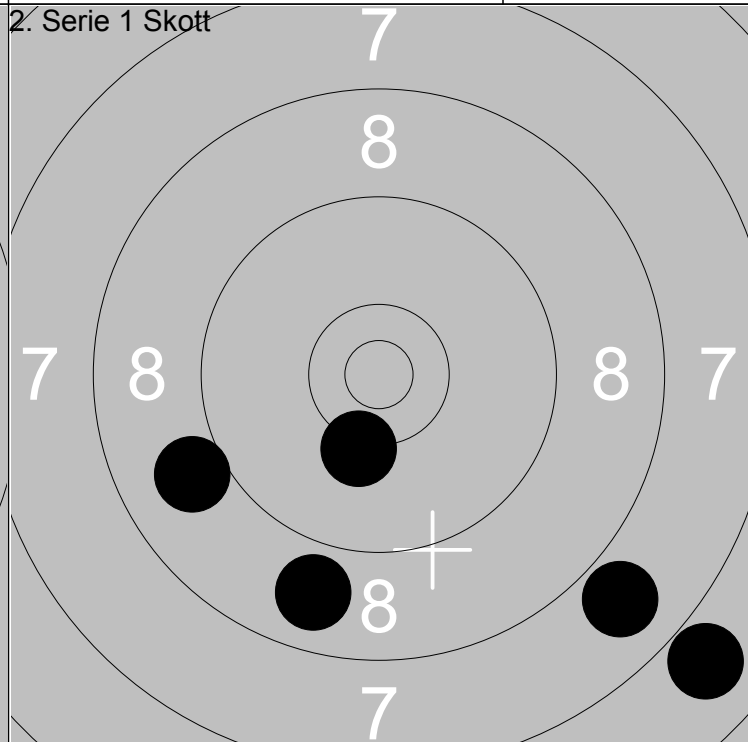
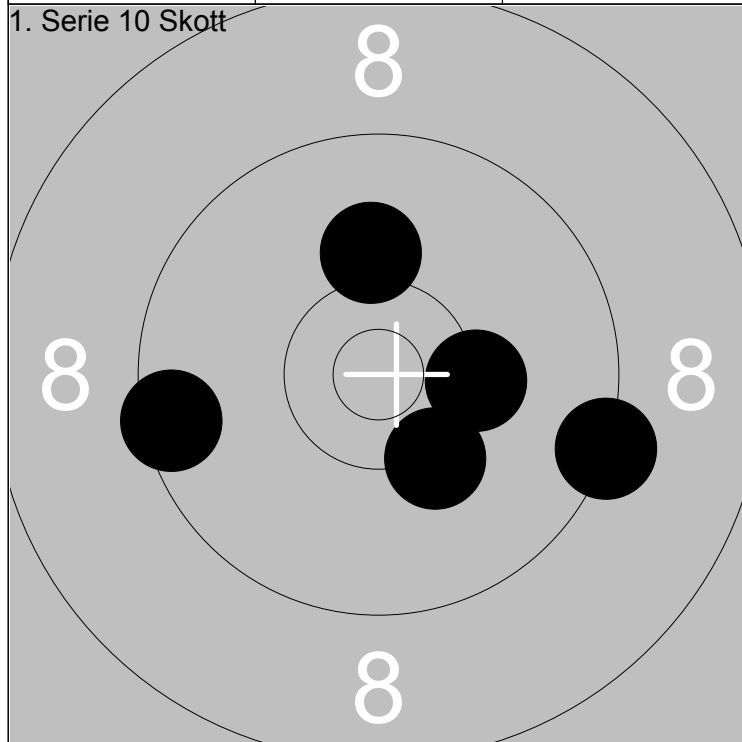

6: 10.3 ↓	Serie	48.0
7: 9.5 ←		
8: 10.3 →	Total	270.0
9: 10.1 ↑		
10: 9.3 →		

1: 9.0 ←	Serie	40.0
2: 10.2 ↓		
3: 6.9 ↓	Total	310.0
4: 7.9 ↓		
5: 8.8 ↓		

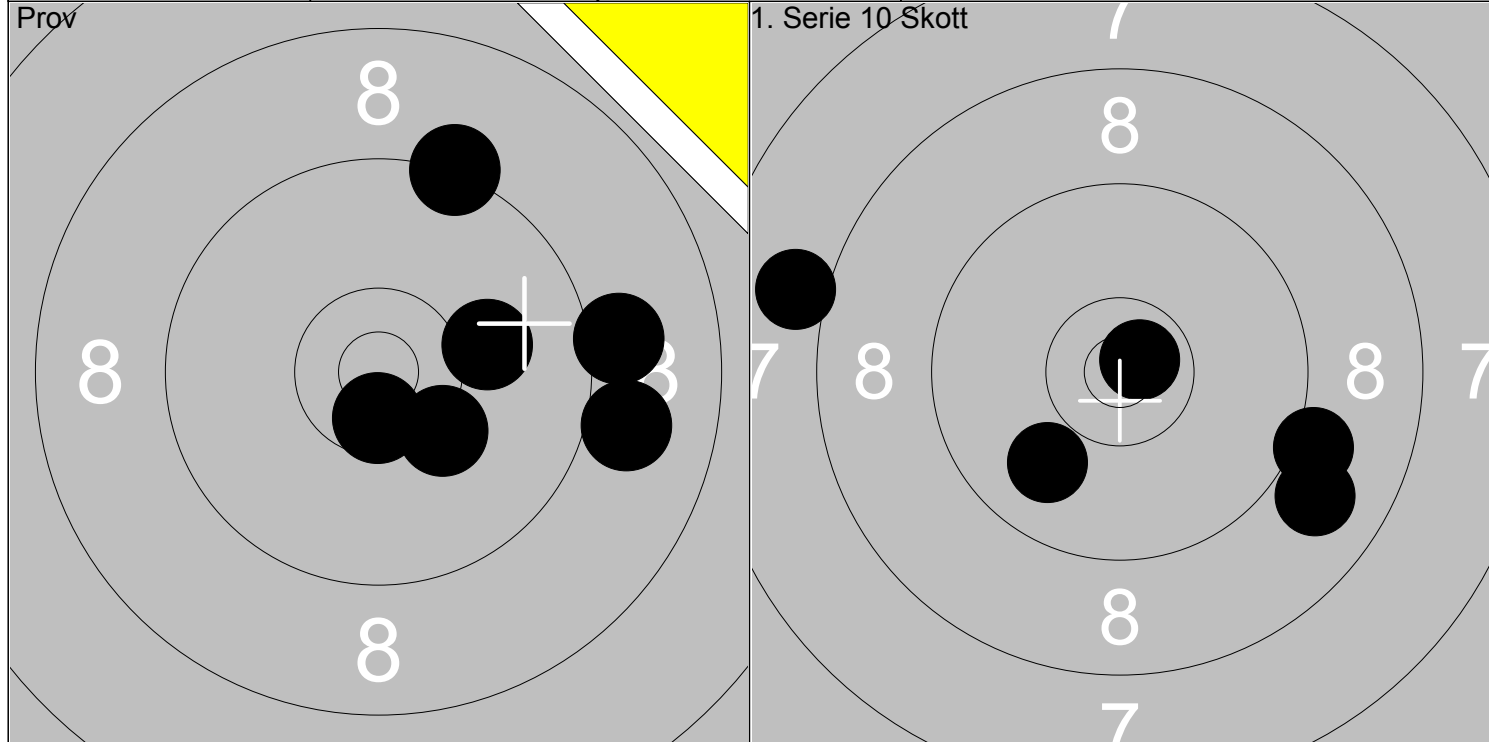

1: 7.7 ↗	6: 10.3 ↘			1: 8.0 ←			
2: 9.0 →	7: *10.6 ↓	Serie	64.0	2: 9.9 ↘	Serie	44.0	Total
3: 9.3 ↑			Total	176.0		3: *10.8 ↗	
4: 10.1 →				4: 9.1 →			
5: 9.1 →				5: 8.9 ↘			

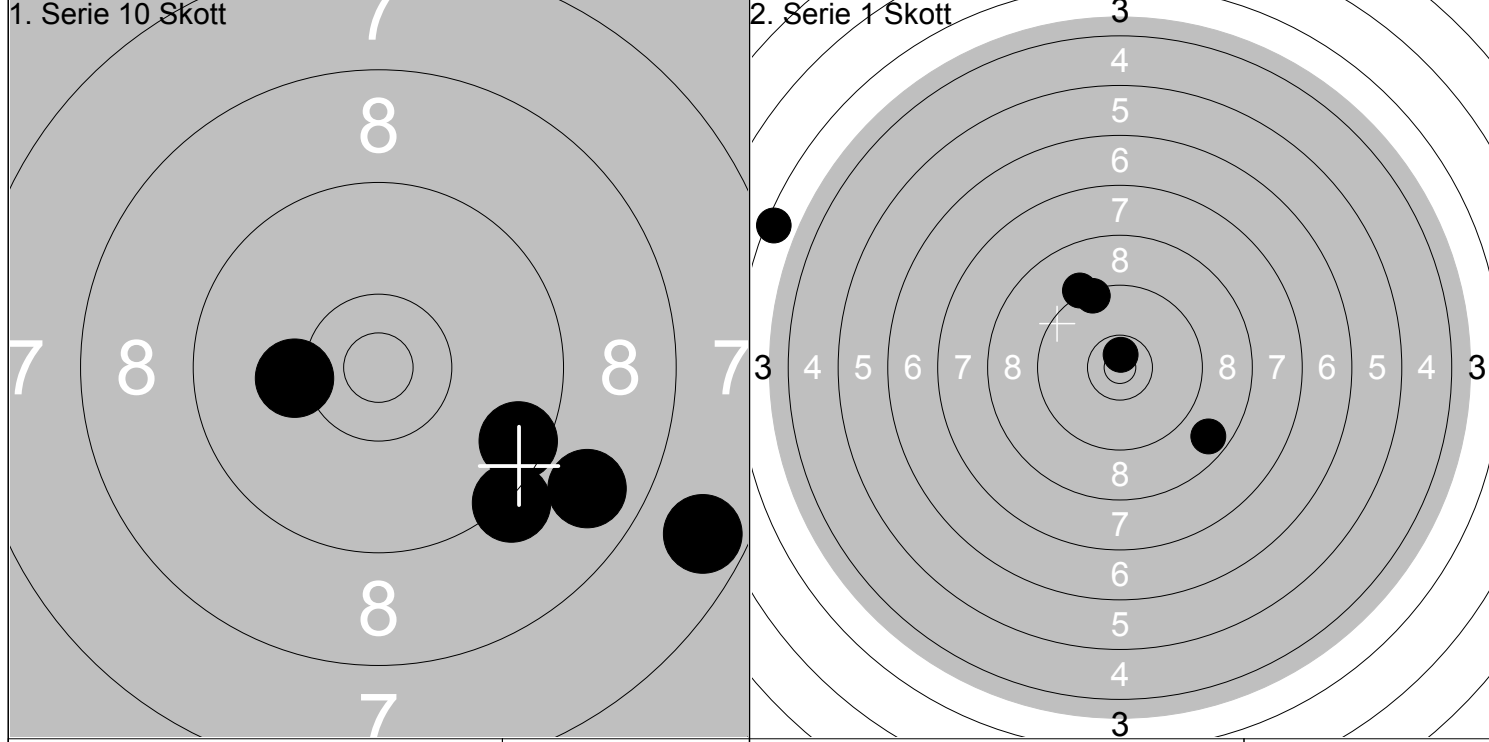

6: 9.3 ↘				1: 3.4 ←			
7: 10.2 ←		Serie	43.0	2: 8.7 ↘	Serie	39.0	Total
8: 7.7 ↘			Total	263.0		3: 9.2 ↗	
9: 9.5 ↘				4: *10.7 ↑			
10: 8.8 ↘				5: 9.4 ↗			

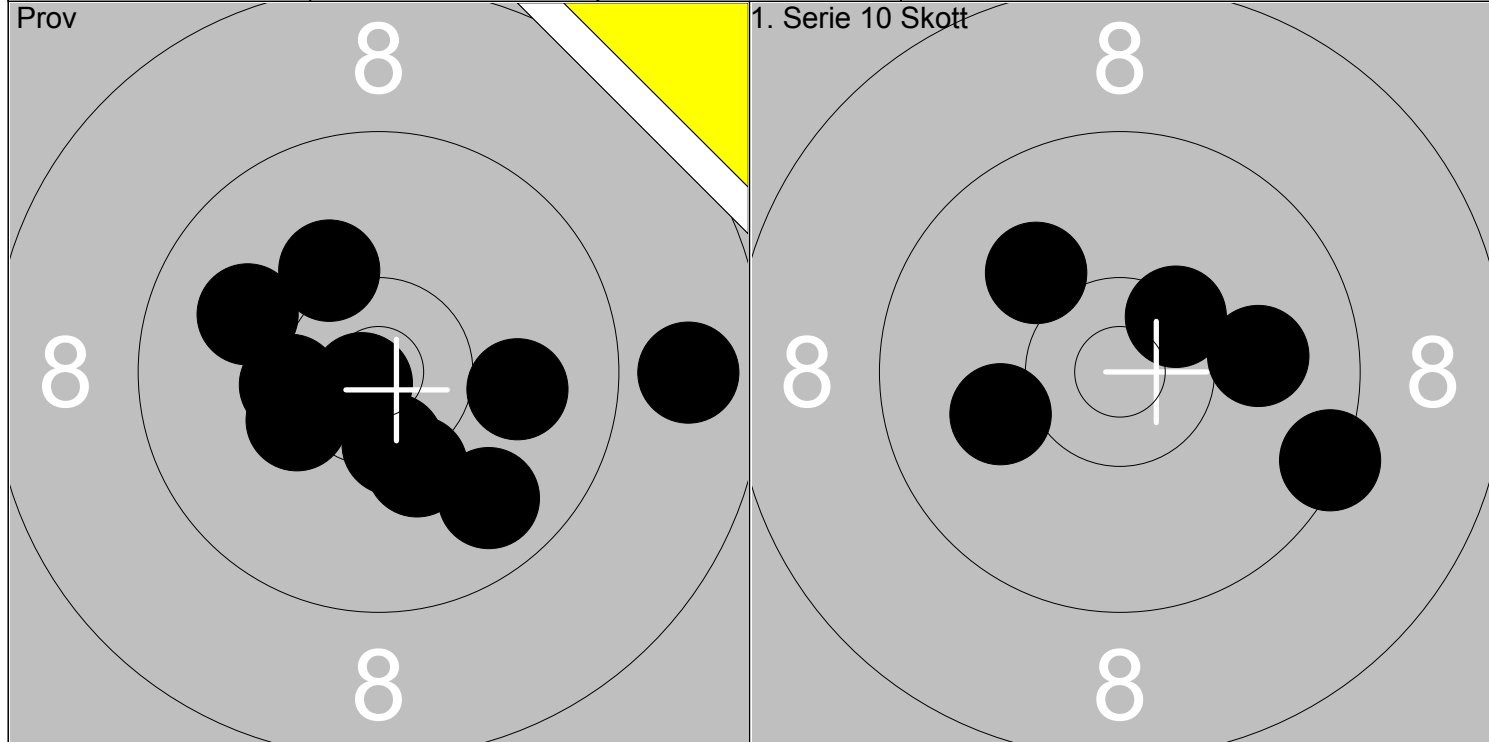

1: 10.2 ↗	6: *10.8 ↘			1: 10.1 ↖			
2: 8.8 →	7: 10.0 →	Serie	97.0	2: 10.0 →		Serie	49.0
3: 9.8 ↘	8: *10.3 ↘			3: *10.4 ↗			
4: 10.0 ↖	9: *10.4 ↘	Total	189.0	4: 10.1 ↖		Total	238.0
5: 10.2 ↘	10: *10.3 ↖			5: 9.4 ↗			

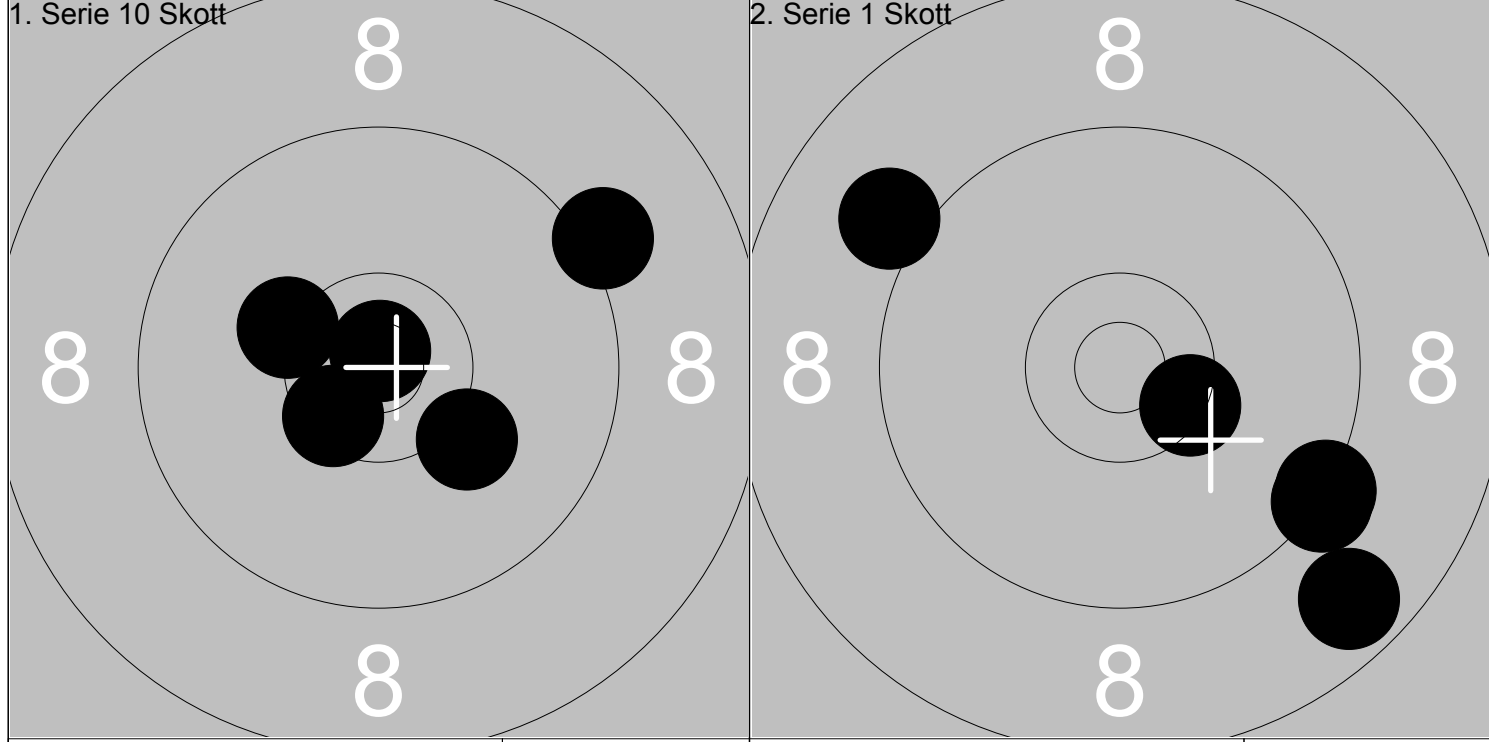

6: 10.3 ↖	1: 9.1 ↗			2: 8.7 ↘			
7: *10.5 ↘	2: 8.7 ↘	Serie	49.0	3: *10.4 ↗		Serie	45.0
8: *10.8 ↑	3: *10.4 ↗			4: 9.3 ↘			
9: 9.2 ↗	4: 9.3 ↘	Total	287.0	5: 9.3 ↘		Total	332.0
10: 10.2 ↘	5: 9.3 ↘						

	<p>1: 9.8 →</p> <p>2: 10.2 ↙</p> <p>3: 9.5 ↑</p> <p>4: 9.2 ↗</p> <p>5: 9.2 →</p> <p>6: 9.4 →</p> <p>7: *10.4 →</p> <p>8: 7.4 →</p> <p>9: 9.1 ←</p> <p>10: 9.9 ↗</p>		<p>11: 10.0 →</p> <p>12: *10.6 ↘</p> <p>13: 9.2 ↘</p> <p>14: 10.2 ↗</p> <p>15: 8.5 ↗</p> <p>16: 9.9 →</p> <p>17: 9.3 ↘</p>
Serie 90.0		Serie 65.0	
Total 181.0		Total 181.0	

<p>1. Serie 10 Skott</p>	<p>1: 9.8 ↓</p> <p>2: *10.3 →</p> <p>3: 9.4 ↑</p> <p>4: 8.7 ↗</p> <p>5: 10.0 →</p>	<p>1. Serie 10 Skott</p>	<p>6: *10.4 ↗</p> <p>7: 9.9 ↗</p> <p>8: *10.3 ↗</p> <p>9: *10.4 →</p> <p>10: 9.9 ←</p>
Serie 46.0		Serie 48.0	
Total 227.0		Total 275.0	

<p>2. Serie 1 Skott</p>	<p>1: *10.5 ↘</p> <p>2: 10.2 →</p> <p>3: *10.4 ↘</p> <p>4: *10.4 ↘</p> <p>5: 9.7 →</p>		
Serie 49.0			
Total 324.0			

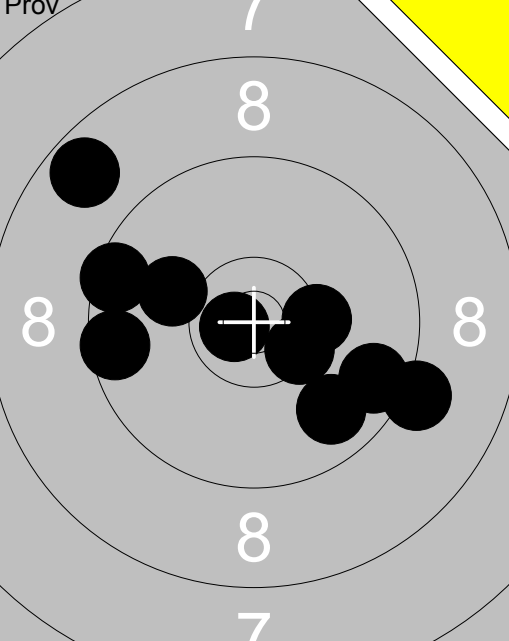
	<p>1: 9.8 ↘</p> <p>2: 9.6 →</p> <p>3: 8.7 ↖</p> <p>4: *10.8 ←</p> <p>5: *10.3 →</p> <p>6: *10.4 ↘</p> <p>7: 9.5 ←</p> <p>8: 9.2 →</p> <p>9: 9.5 ←</p> <p>10: 10.1 ↖</p>	<p>11: 9.9 ↓</p> <p>12: 9.9 ↓</p> <p>13: 10.3 ↗</p> <p>14: 9.6 ↖</p> <p>15: 9.2 ←</p> <p>16: 9.6 →</p> <p>17: *10.5 ↗</p> <p>18: 9.2 ↖</p>
Serie 93.0		Serie 74.0
Total 197.0		Total 197.0

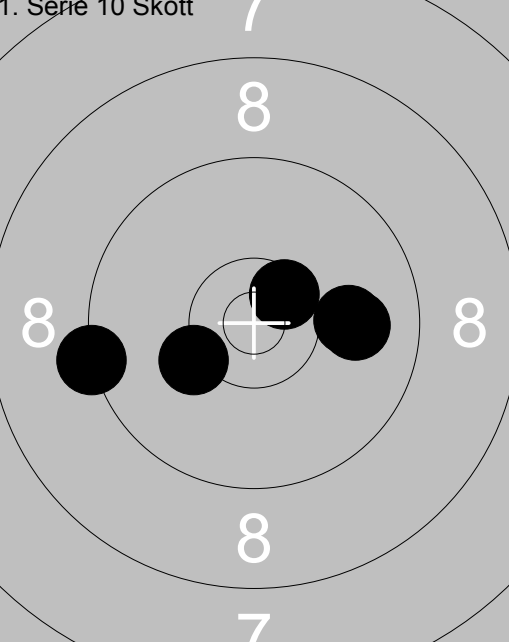
<p>1. Serie 10 Skott</p> 	<p>1: 10.0 →</p> <p>2: 10.2 ↖</p> <p>3: *10.5 ↗</p> <p>4: 9.9 →</p> <p>5: 9.3 ←</p>	<p>6: 9.6 ↓</p> <p>7: 10.0 →</p> <p>8: 10.1 ↓</p> <p>9: 10.0 ↓</p> <p>10: 9.2 ↖</p>
Serie 48.0		Serie 48.0
Total 245.0		Total 293.0

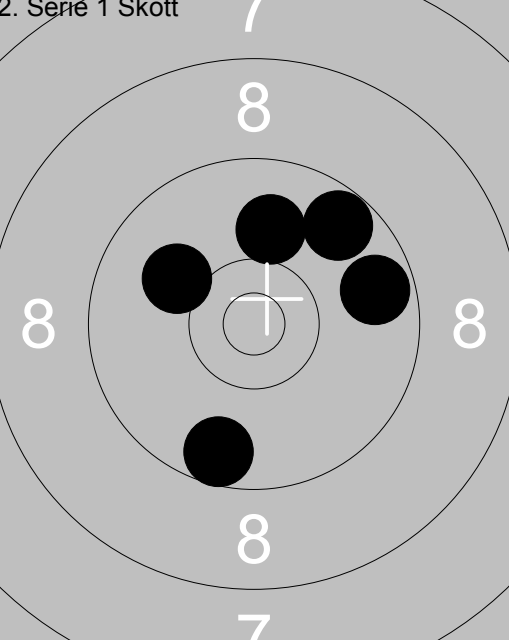
<p>2. Serie 1 Skott</p> 	<p>1: 9.7 →</p> <p>2: 9.6 ↓</p> <p>3: 10.1 ↖</p> <p>4: 10.0 ↗</p> <p>5: 9.7 ↗</p>	
Serie 47.0		
Total 340.0		

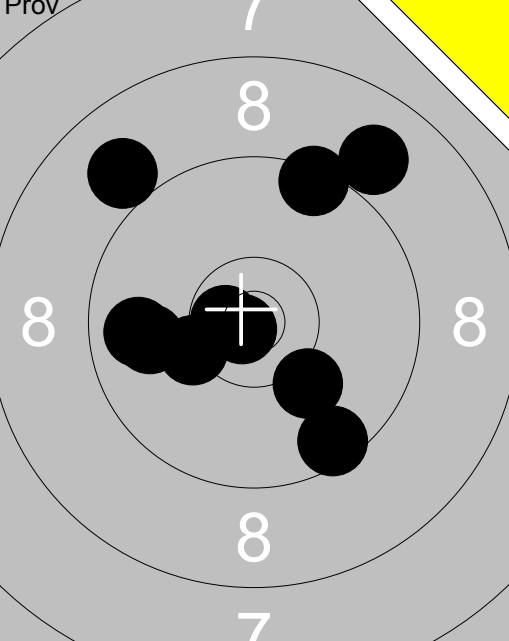
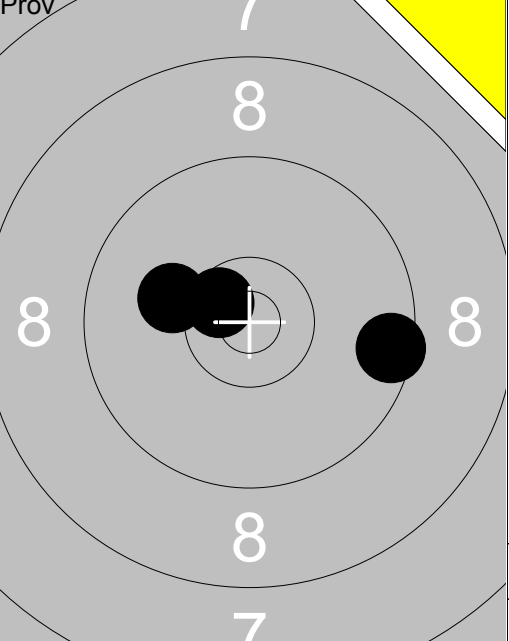
	<p>1: 8.9 ↗</p> <p>2: *10.8 ↘</p> <p>3: 10.3 ↙</p> <p>4: 9.0 ↖</p> <p>5: 9.4 ↗</p> <p>6: 9.5 ↘</p> <p>7: *10.7 ↖</p> <p>8: 9.8 ←</p> <p>9: 9.9 ←</p> <p>10: 10.1 ↘</p>		<p>11: 9.5 →</p> <p>12: *10.6 ↖</p> <p>13: 10.1 ←</p>
Serie 93.0		Serie 29.0	
Total 190.0		Total 190.0	

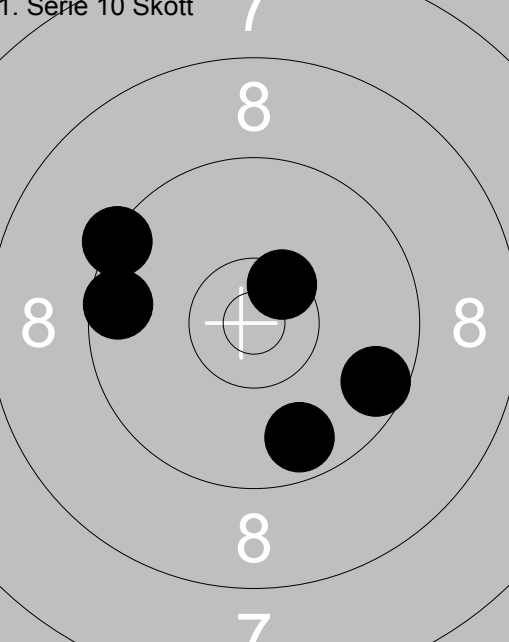
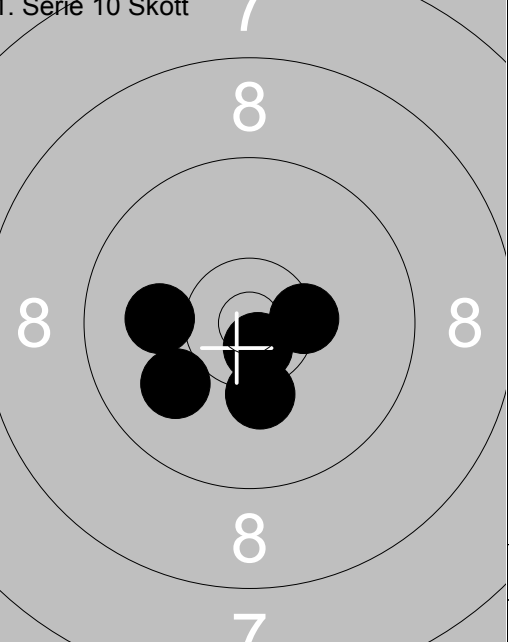
<p>1. Serie 10 Skott</p> 	<p>1: 9.6 ←</p> <p>2: 9.6 →</p> <p>3: 9.4 ↖</p> <p>4: *10.5 ↗</p> <p>5: 9.7 ↘</p>	<p>1. Serie 10 Skott</p> 	<p>6: 10.0 ↙</p> <p>7: *10.7 ↘</p> <p>8: *10.4 →</p> <p>9: 10.0 ←</p> <p>10: 10.2 ↘</p>
Serie 46.0		Serie 50.0	
Total 236.0		Total 286.0	

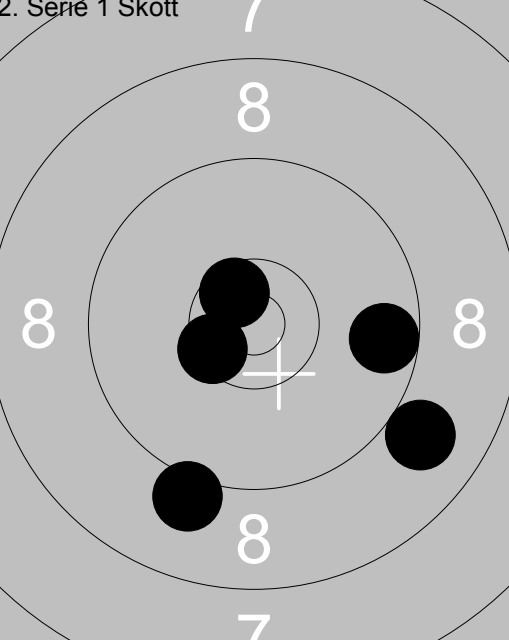
<p>2. Serie 1 Skott</p> 	<p>1: *10.5 ↘</p> <p>2: 9.0 ↘</p> <p>3: 9.1 ↘</p> <p>4: *10.6 ↖</p> <p>5: 9.6 →</p>		
Serie 47.0			
Total 333.0			

	<p>1: 7.7 ↙</p> <p>2: 9.7 ↘</p> <p>3: 9.1 ↑</p> <p>4: 9.3 ↗</p> <p>5: 9.4 ↑</p> <p>6: 9.6 ↗</p> <p>7: *10.3 ↑</p> <p>8: 8.6 ↖</p> <p>9: 8.9 ↑</p> <p>10: *10.5 ↘</p>	<p>Prov</p>	<p>11: 8.9 ↗</p> <p>12: 10.0 ↘</p> <p>13: 9.1 ↗</p> <p>14: 10.2 ↙</p> <p>15: 9.8 ↖</p>
Serie 88.0		Serie 46.0	
Total 190.0		Total 190.0	

<p>1. Serie 10 Skott</p>	<p>1: 10.0 ↑</p> <p>2: 10.2 ↙</p> <p>3: 10.2 ↖</p> <p>4: 8.9 →</p> <p>5: 9.5 ↗</p>	<p>1. Serie 10 Skott</p>	<p>6: 9.8 ↘</p> <p>7: 8.9 ↑</p> <p>8: *10.6 ↘</p> <p>9: *10.5 ↙</p> <p>10: 9.9 ↑</p>
Serie 47.0		Serie 46.0	
Total 237.0		Total 283.0	

<p>2. Serie 1 Skott</p>	<p>1: 9.3 →</p> <p>2: 9.4 →</p> <p>3: 9.6 ↗</p> <p>4: 10.0 ←</p> <p>5: 8.6 →</p>		
Serie 45.0			
Total 328.0			

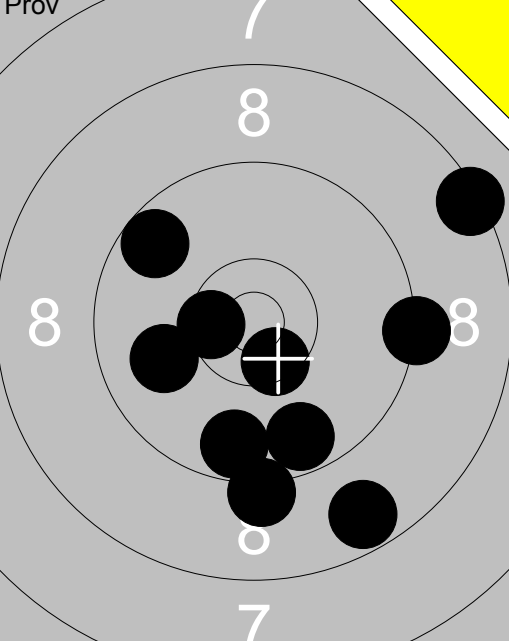
	<p>1: 9.7 ↓</p> <p>2: 9.3 →</p> <p>3: 10.0 ←</p> <p>4: *10.5 ←</p> <p>5: 8.7 ↓</p> <p>6: 9.7 ↓</p> <p>7: *10.5 ↓</p> <p>8: 9.7 ↖</p> <p>9: 9.2 ↓</p> <p>10: 8.4 ↗</p>	<p>11: *10.7 ↗</p> <p>12: *10.4 ↘</p> <p>13: 9.0 →</p> <p>14: 9.0 ↖</p> <p>15: 8.9 ↗</p> <p>16: 9.2 →</p> <p>17: 10.0 ←</p>
Serie 91.0		Serie 65.0
Total 184.0		Total 184.0

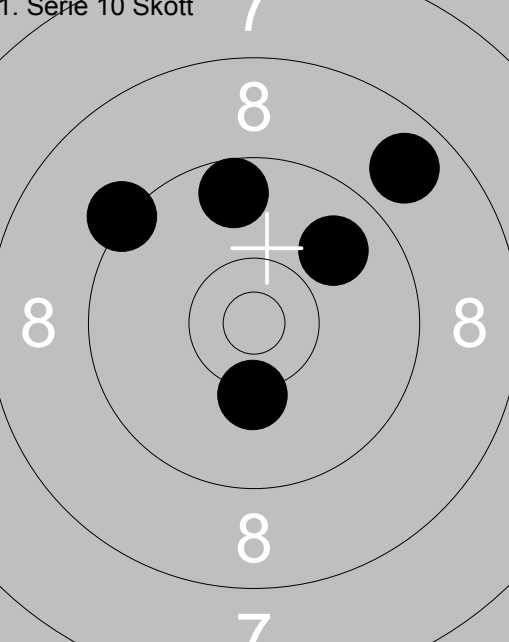
<p>1. Serie 10 Skott</p> 	<p>1: 10.2 ↓</p> <p>2: 9.6 ↑</p> <p>3: 9.3 ↖</p> <p>4: 8.8 ↗</p> <p>5: 9.9 ↗</p>	<p>6: *10.5 ↖</p> <p>7: *10.4 ↓</p> <p>8: 9.6 →</p> <p>9: 9.8 ↓</p> <p>10: 9.1 →</p>
Serie 45.0		Serie 47.0
Total 229.0		Total 276.0

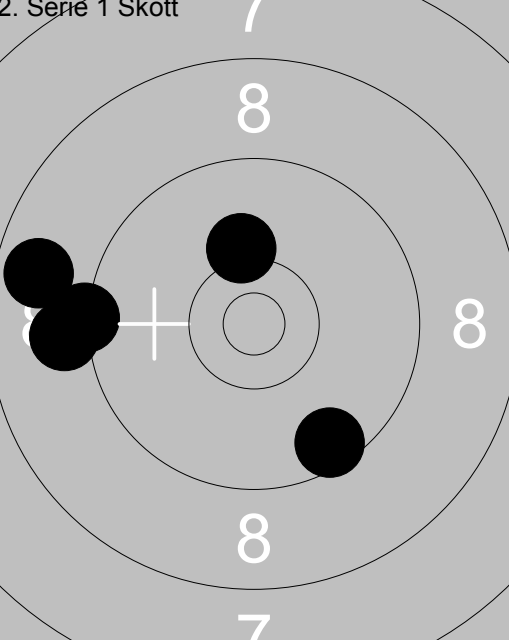
<p>2. Serie 1 Skott</p> 	<p>1: 8.7 ←</p> <p>2: 9.5 ↓</p> <p>3: 9.3 ←</p> <p>4: 9.0 ←</p> <p>5: 10.2 ↑</p>	
Serie 45.0		
Total 321.0		

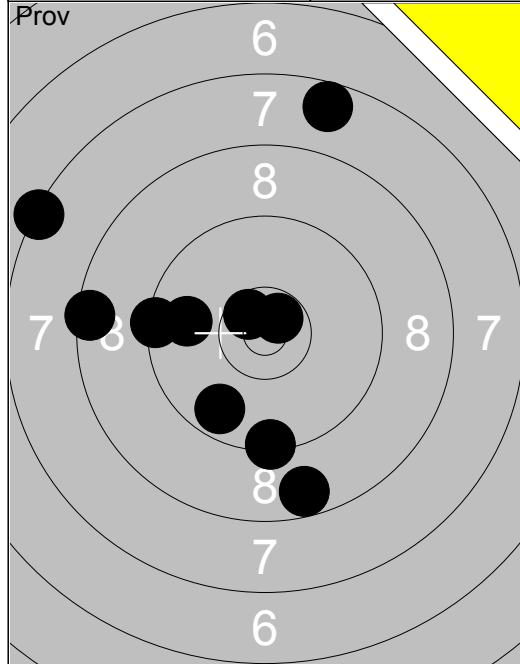

1:	9.8	←
2:	9.4	↓
3:	*10.6	↙
4:	7.6	↑
5:	8.7	↓
6:	*10.7	↗
7:	9.7	↓
8:	7.4	←
9:	9.4	←
10:	8.5	←
Serie		86.0
Total		178.0

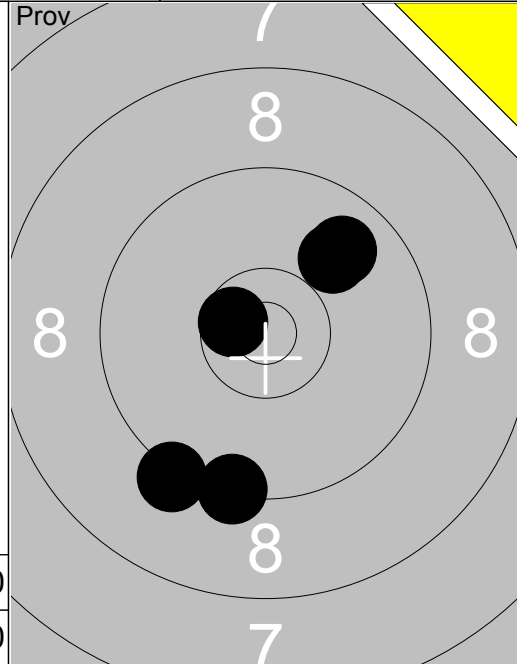

11:	9.2	↙
12:	9.8	↗
13:	9.4	↓
14:	9.9	↗
15:	*10.6	↙
Serie		46.0
Total		178.0

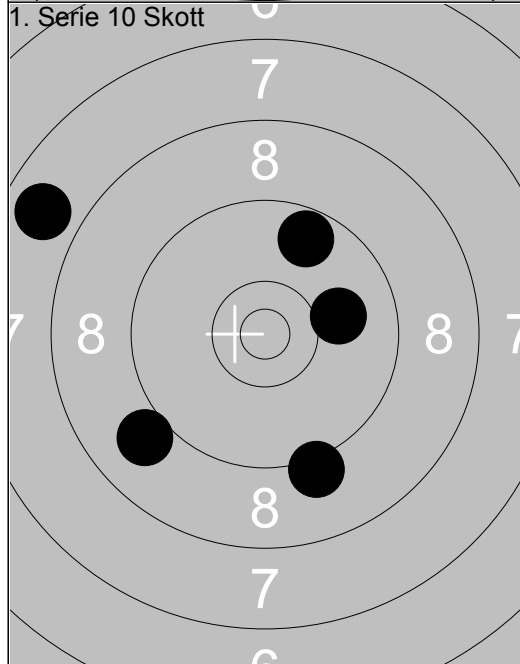

1:	9.0	↙
2:	9.2	↓
3:	9.7	↗
4:	7.8	←
5:	10.0	→
Serie		44.0
Total		222.0

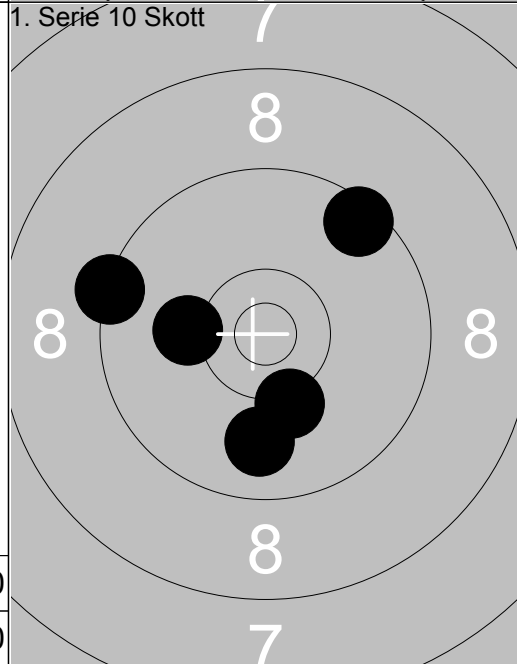

6:	9.9	↓
7:	10.2	←
8:	9.5	↗
9:	9.3	←
10:	10.2	↓
Serie		47.0
Total		269.0

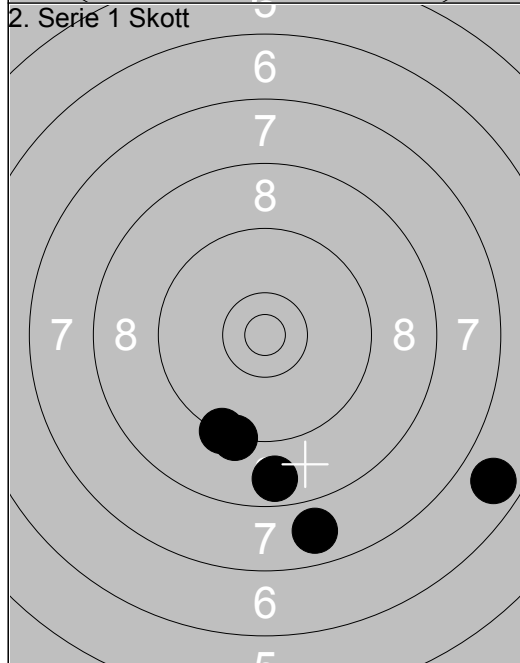

1:	9.3	↓
2:	6.8	→
3:	9.3	↓
4:	8.7	↓
5:	7.8	↓
Serie		39.0
Total		308.0

--	--	--

	<p>Prov</p> <p>1: 6.8 →</p> <p>2: 9.6 →</p> <p>3: 8.6 ↖</p> <p>4: 10.0 →</p> <p>5: 9.9 ↓</p> <p>6: 8.1 ↓</p> <p>7: 9.9 ↓</p> <p>8: *10.8 ↗</p> <p>9: 9.2 ↓</p> <p>10: 8.6 ↓</p>		<p>Prov</p> <p>11: 9.6 ←</p> <p>12: 9.6 →</p> <p>13: 10.1 ↗</p> <p>14: 9.5 ↓</p> <p>15: 8.6 ←</p>
Serie 86.0		Serie 45.0	
Total 164.0		Total 164.0	

<p>1. Serie 10 Skott</p>	<p>1: 9.7 →</p> <p>2: 9.6 ↓</p> <p>3: 9.8 ↗</p> <p>4: 9.3 ↓</p> <p>5: 9.4 ↓</p>	<p>1. Serie 10 Skott</p>	<p>6: 10.3 ↗</p> <p>7: 8.9 ↓</p> <p>8: 9.5 ↑</p> <p>9: 10.0 ↓</p> <p>10: 10.1 ↖</p>
Serie 45.0		Serie 47.0	
Total 209.0		Total 256.0	

<p>2. Serie 1 Skott</p>	<p>1: 9.3 ↓</p> <p>2: 10.0 →</p> <p>3: 10.2 ↓</p> <p>4: 9.3 ↓</p> <p>5: 9.9 ↓</p>		
Serie 47.0			
Total 303.0			

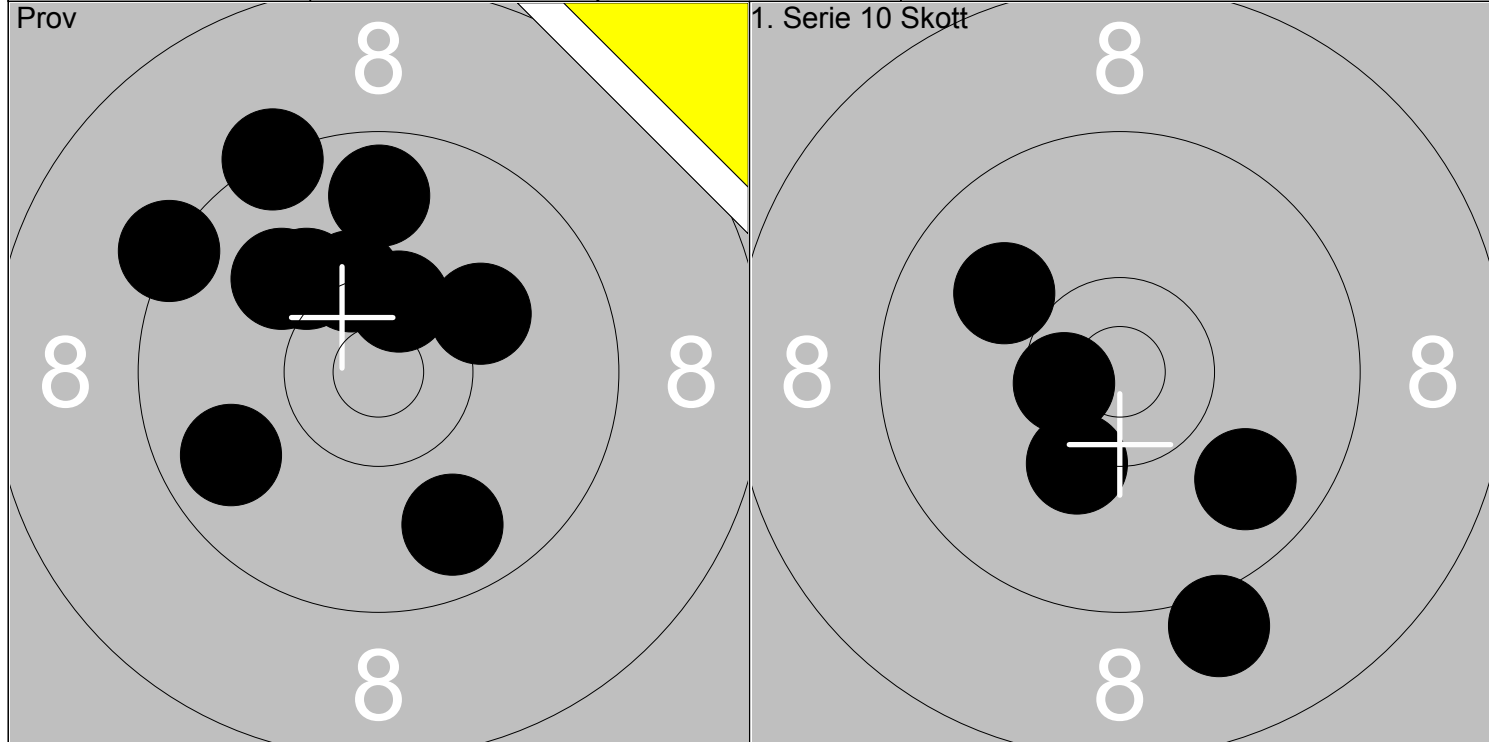

1: 9.3 ↖	6: 10.0 ↖			1: 9.8 ↘			
2: 9.8 ↘	7: *10.3 ↗	Serie	95.0	2: *10.6 ↖	Serie	48.0	
3: 9.3 ↗	8: 9.8 ↙			3: 10.3 ↘			
4: 9.7 ↗	9: *10.4 ↗	Total	191.0	4: 9.1 ↘			
5: 10.1 ↗	10: 10.1 ↖			5: 10.0 ↖	Total	239.0	

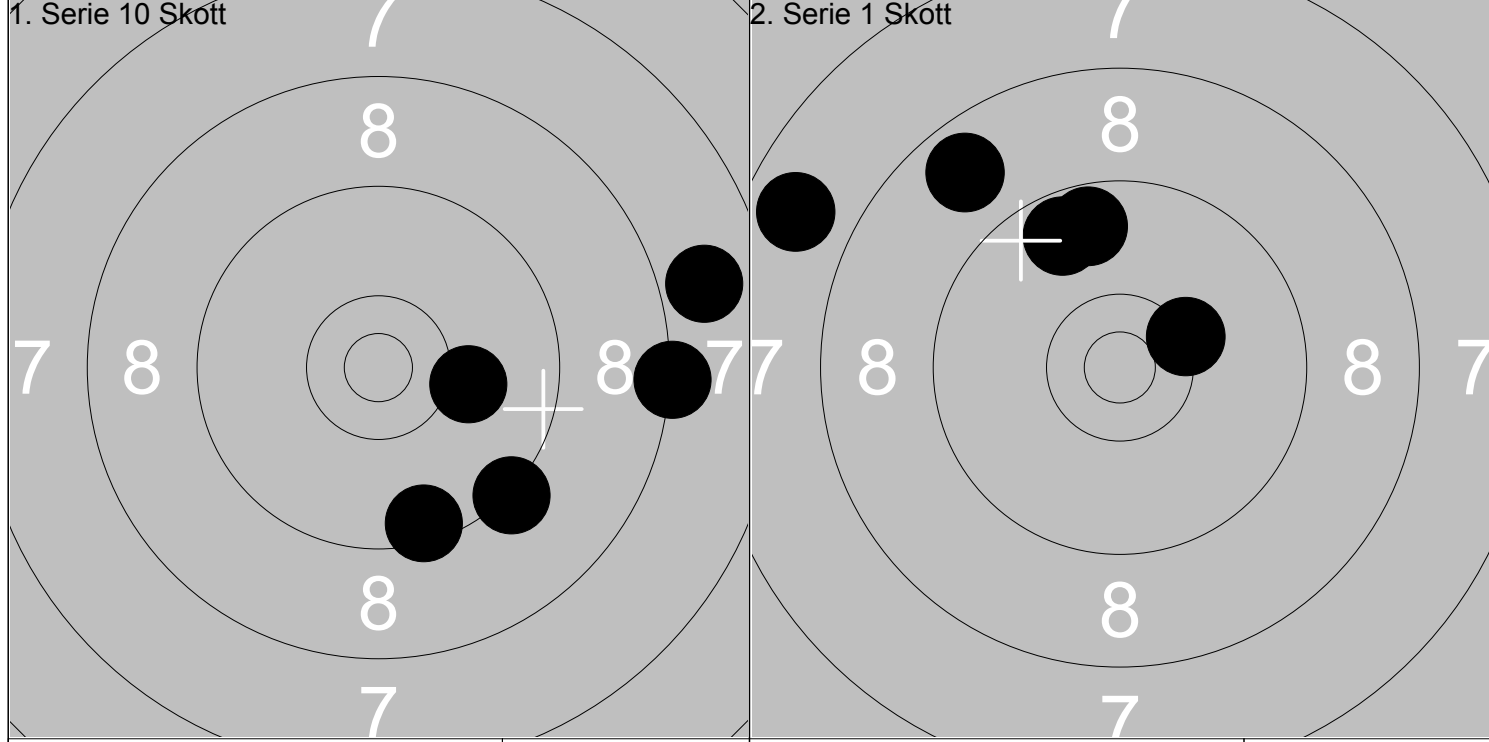

6: 9.5 ↘				1: 9.7 ↗			
7: 7.9 →		Serie	43.0	2: 7.8 ↖	Serie	43.0	
8: 8.3 →				3: *10.3 ↗			
9: 10.1 →		Total	282.0	4: 8.7 ↖			
10: 9.3 ↘				5: 9.7 ↗	Total	325.0	

	<p>1: *10.3 →</p> <p>2: 9.2 ↗</p> <p>3: 8.7 →</p> <p>4: 9.3 ↗</p> <p>5: 10.2 ↑</p> <p>6: 10.2 ↖</p> <p>7: 9.8 ↓</p> <p>8: *10.5 →</p> <p>9: 9.5 ↑</p> <p>10: 10.0 ↖</p>	<p>11: 9.7 →</p> <p>12: 9.6 ↖</p> <p>13: *10.6 ↖</p> <p>14: 9.8 ↑</p> <p>15: *10.5 ↗</p>
Serie 94.0		Serie 47.0
Total 186.0		Total 186.0

<p>1. Serie 10 Skott</p>	<p>1: 10.0 →</p> <p>2: *10.8 ↘</p> <p>3: 9.9 ↗</p> <p>4: *10.4 ↗</p> <p>5: 10.2 ↖</p>	<p>6: 10.1 →</p> <p>7: 7.3 →</p> <p>8: *10.5 ↖</p> <p>9: 9.8 ↓</p> <p>10: *10.7 ↘</p>
Serie 49.0		Serie 46.0
Total 235.0		Total 281.0

<p>2. Serie 1 Skott</p>	<p>1: 8.5 ↖</p> <p>2: 7.5 ↓</p> <p>3: 8.1 ↗</p> <p>4: 8.1 ↓</p> <p>5: 8.4 →</p>	
Serie 39.0		
Total 320.0		

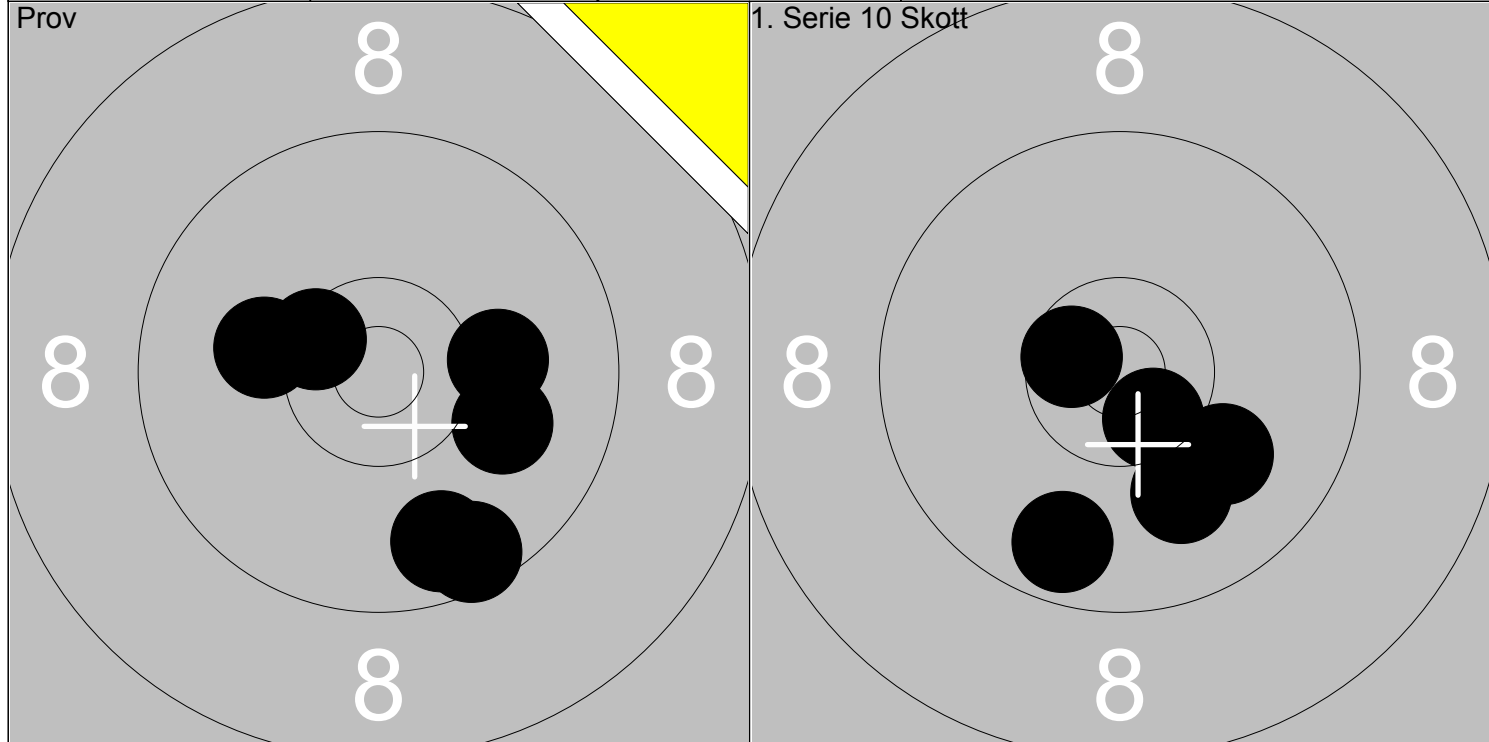

1: *10.5 ↗	6: 10.1 ←						
2: 9.7 ↓		Serie	58.0	1: 9.7 ↓		Serie	49.0
3: 9.6 ↓				2: 10.0 ↓			
4: 10.0 →		Total	178.0	3: *10.6 ↘		Total	227.0
5: 10.1 →				4: 10.0 →			
				5: *10.6 ↗			

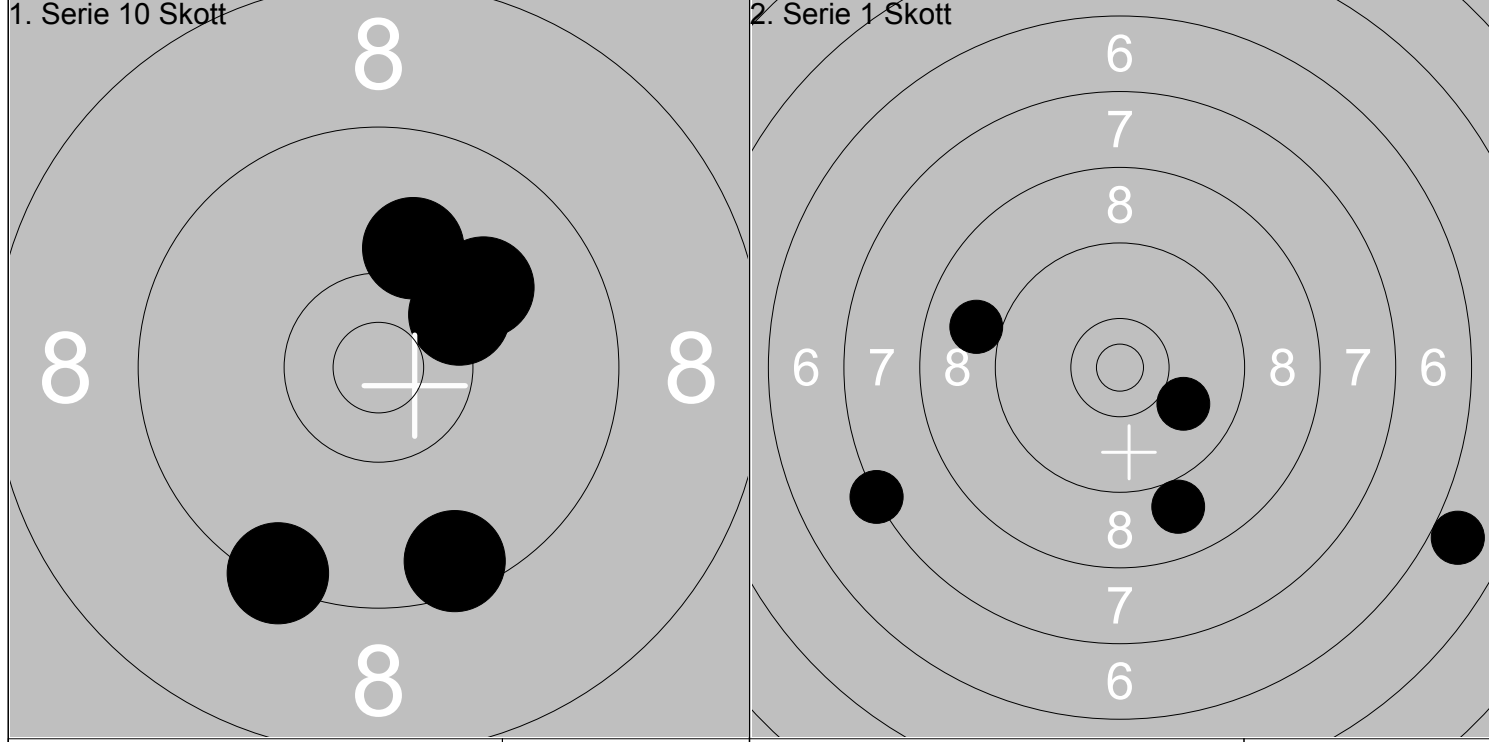

6: 9.5 ↓							
7: 10.0 ↗		Serie	48.0	1: 7.3 ←		Serie	40.0
8: 10.3 ↗				2: 5.9 →			
9: 10.1 ↑		Total	275.0	3: 9.0 ↓		Total	315.0
10: 9.4 ↓				4: 10.0 →			
				5: 9.0 ←			

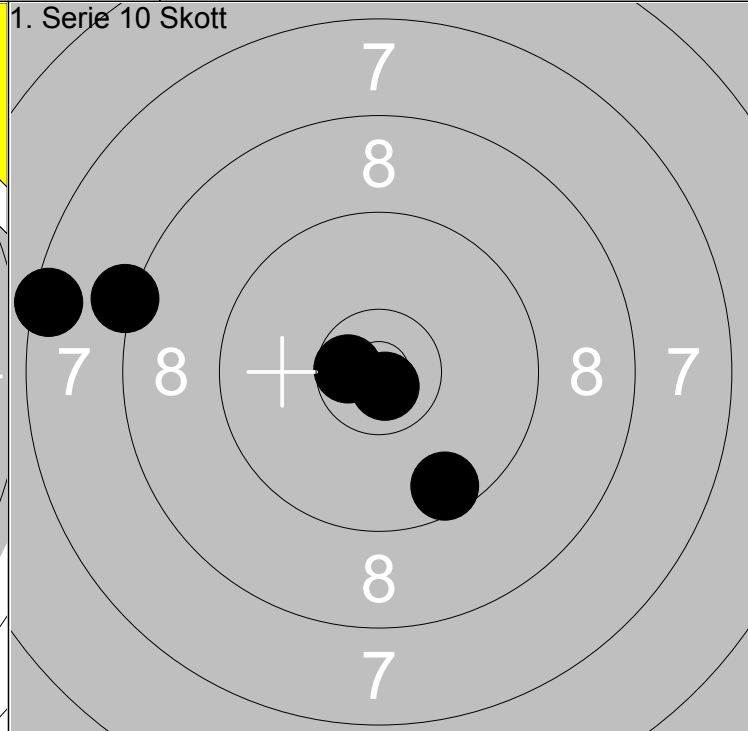
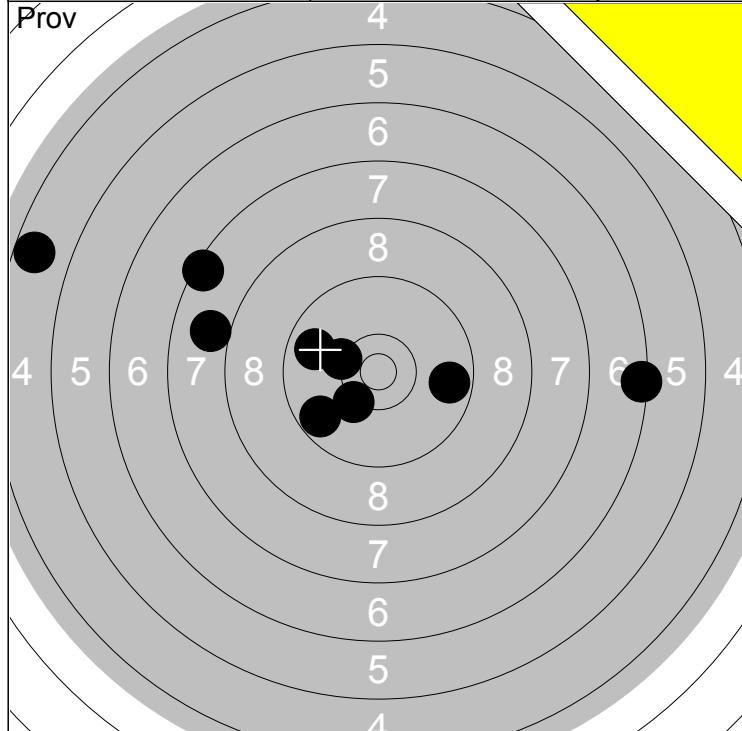

1: 6.4 →	6: 10.3 ↙	Serie	72.0
2: 9.7 →	7: 10.3 ↖		
3: 9.7 ↙	8: 8.0 ↖	Total	173.0
4: 4.7 ↖	9: 9.8 ↖		
5: 7.4 ↖			

1: 9.6 ↘	Serie	44.0
2: *10.6 ↖		
3: 7.5 ↖	Total	217.0
4: 8.2 ↖		
5: *10.8 ↘		

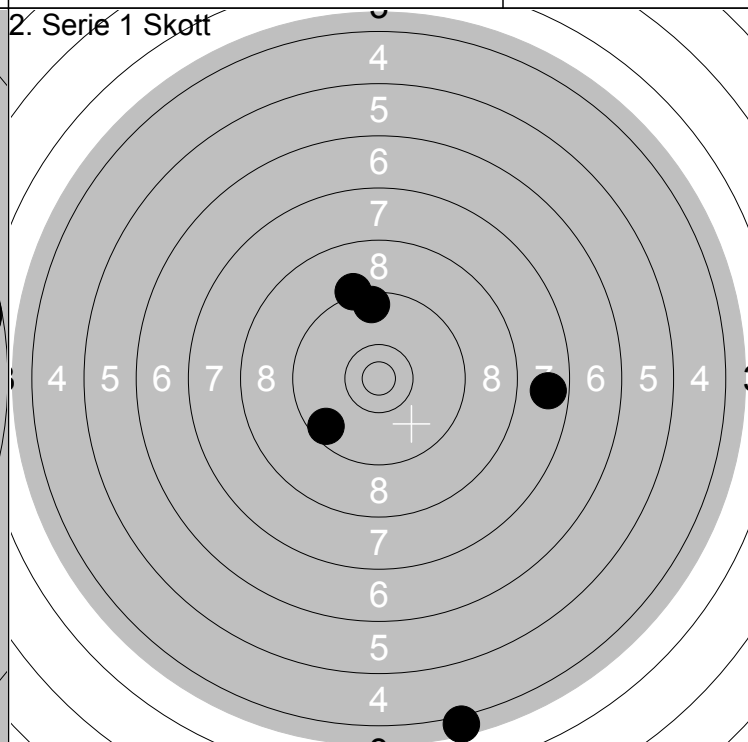
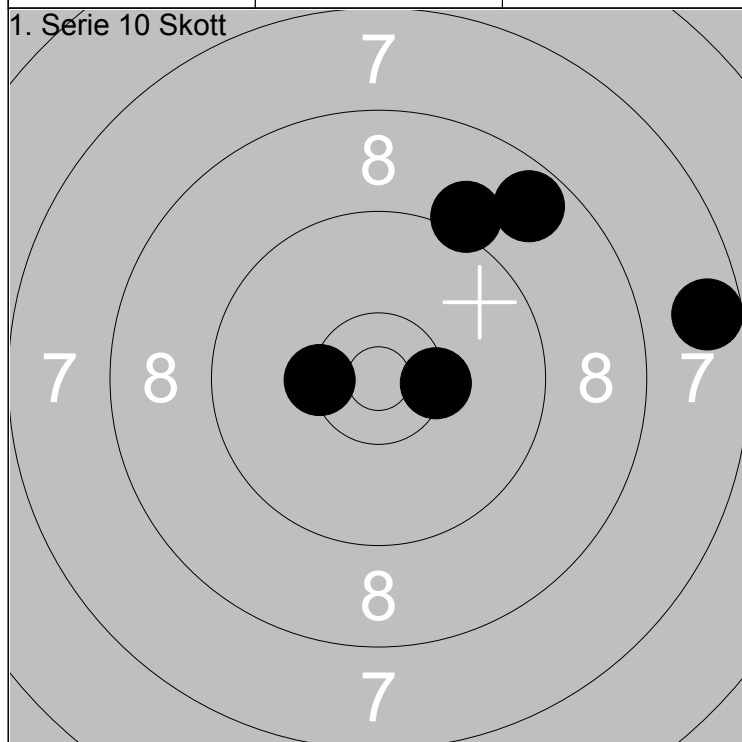

6: 9.1 ↗	Serie	44.0
7: *10.4 ↖		
8: 7.6 →	Total	261.0
9: *10.4 →		
10: 8.7 ↗		

1: 9.2 ↗	Serie	38.0
2: 9.5 ↗		
3: 9.6 ↙	Total	299.0
4: 4.1 ↘		
5: 7.7 →		

	<p>1: 9.9 ↙</p> <p>2: 10.1 ↓</p> <p>3: 8.9 ↗</p> <p>4: 10.0 ↗</p> <p>5: 8.5 ↖</p> <p>6: *10.4 ↘</p> <p>7: 9.3 ↑</p> <p>8: 9.9 ←</p> <p>9: 8.3 ↖</p> <p>10: *10.5 ↘</p>		<p>11: *10.7 ↗</p> <p>12: 9.1 ↖</p> <p>13: 9.1 ↖</p> <p>14: 9.8 ↖</p> <p>15: 9.0 ↖</p>
Serie 91.0		Serie 46.0	
Total 171.0		Total 171.0	

<p>1. Serie 10 Skott</p>	<p>1: 8.9 ↓</p> <p>2: *10.4 ↘</p> <p>3: 9.7 ↖</p> <p>4: 8.1 ↖</p> <p>5: 9.6 ←</p>		<p>6: 8.5 ↗</p> <p>7: 9.8 ↖</p> <p>8: 9.1 ↖</p> <p>9: 9.4 ↗</p> <p>10: 9.1 ↑</p>
Serie 44.0		Serie 44.0	
Total 215.0		Total 259.0	

<p>2. Serie 1 Skott</p>	<p>1: 7.2 ↖</p> <p>2: 6.6 ←</p> <p>3: 3.8 ↖</p> <p>4: 4.1 ↓</p> <p>5: 8.5 →</p>		
Serie 28.0			
Total 287.0			

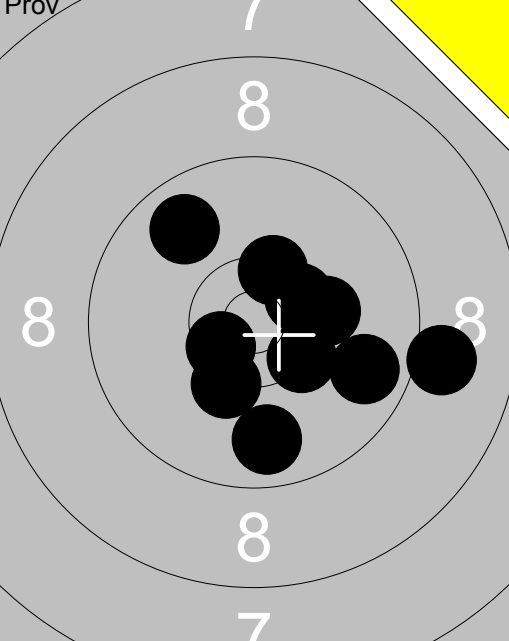
	<p>1: 10.3 ↘ 2: 9.0 → 3: 9.8 ↓ 4: 9.8 ↗ 5: *10.5 ↘ 6: *10.4 ↗ 7: 9.8 → 8: *10.4 ↗ 9: 10.2 → 10: *10.4 ↘</p>	<p>11: *10.4 ↘ 12: 10.3 ↘</p>
Serie 96.0		Serie 20.0
Total 169.0		Total 169.0

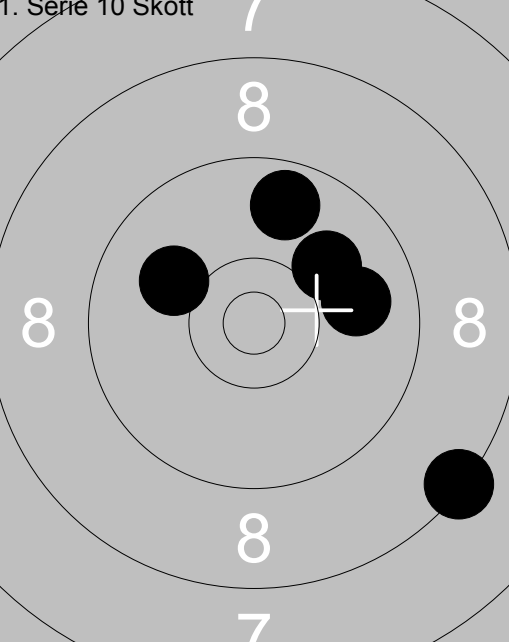
<p>1. Serie 10 Skott</p> 	<p>1: 9.7 ↗ 2: 10.1 ↖ 3: 9.9 → 4: 10.0 ↗ 5: 8.3 ↘</p>	<p>6: 10.0 ↘ 7: *10.6 ↘ 8: *10.3 ↖ 9: 10.1 ↘ 10: 10.1 ↓</p>
Serie 46.0		Serie 50.0
Total 215.0		Total 265.0

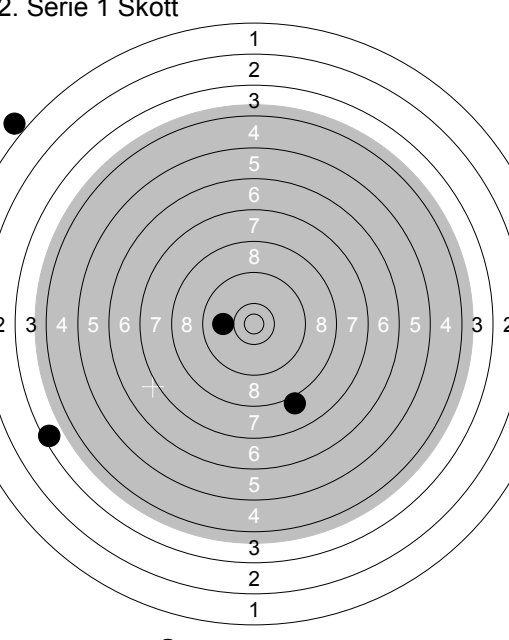
<p>2. Serie 1 Skott</p> 	<p>1: 3.5 ↖ 2: 10.0 ← 3: 0.0 ↖ 4: 0.0 ↓ 5: 8.1 ↓</p>	
Serie 21.0		
Total 286.0		

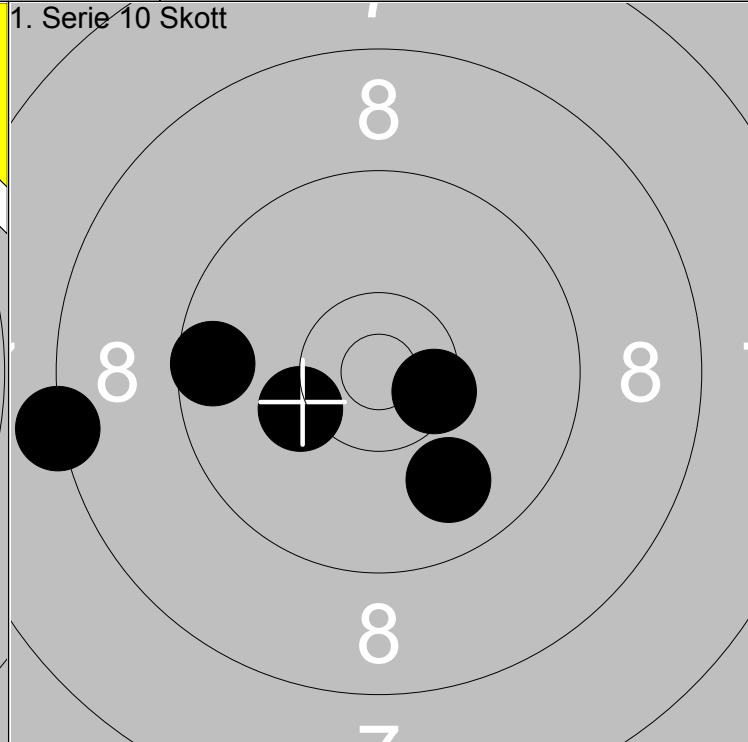
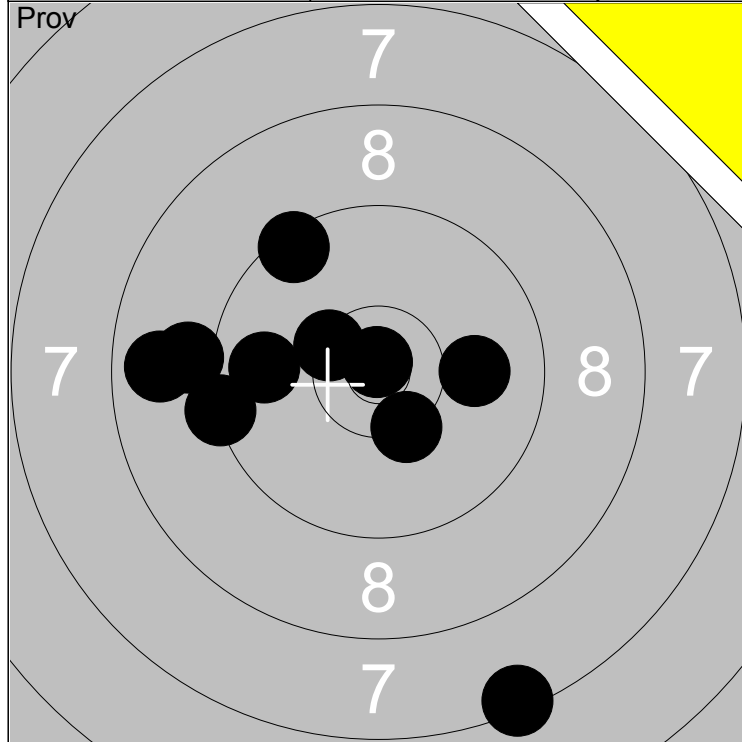

1: 9.1 ←	6: 9.3 ←	Serie	91.0
2: 8.8 ←	7: 10.0 →		
3: *10.9 ↑	8: 9.8 ←	Total	157.0
4: *10.4 ↖	9: *10.3 ↓		
5: 7.4 ↓	10: 9.5 ↗		

1: *10.5 →	Serie	46.0
2: 9.9 ↓		
3: 9.6 ←	Total	203.0
4: 8.3 ←		
5: 10.2 ↙		

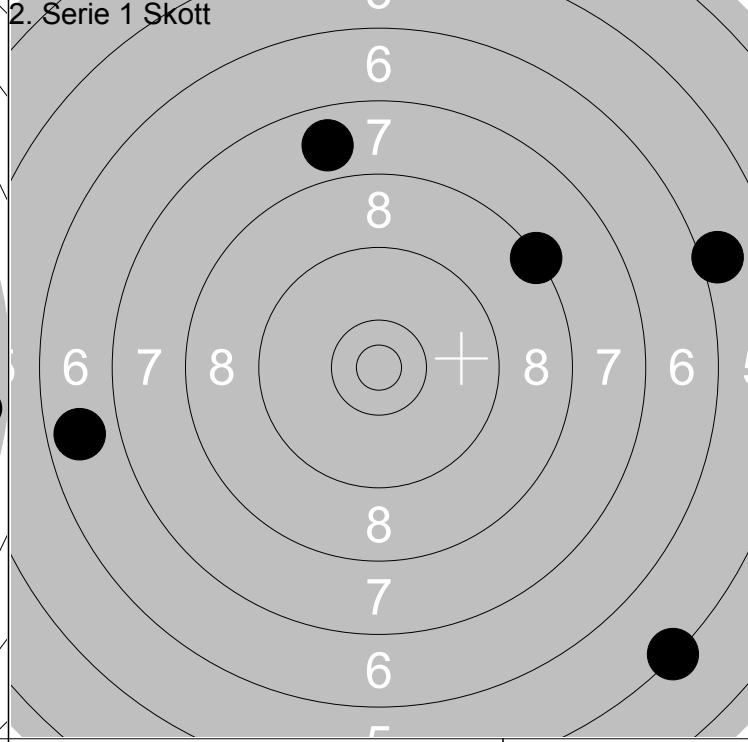
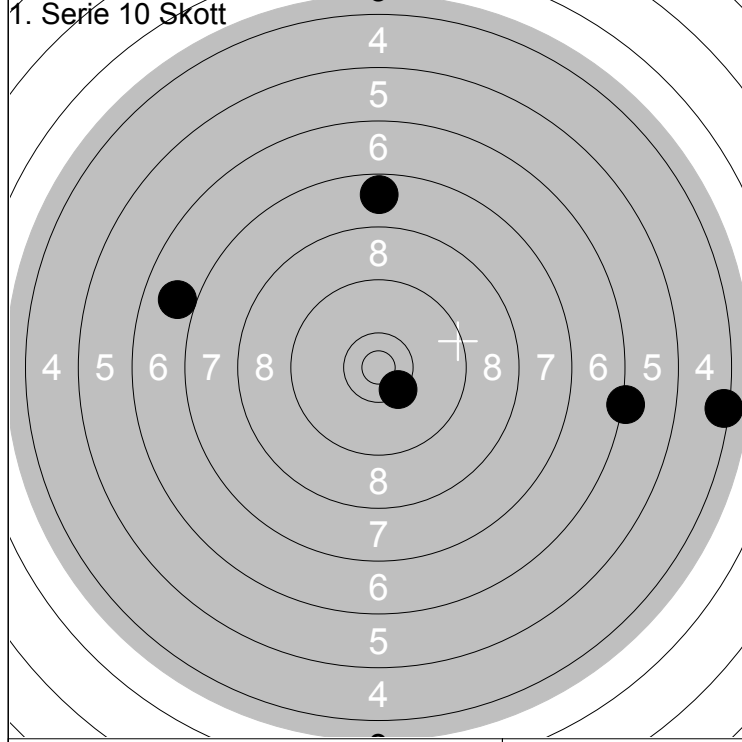

6: 7.0 ←	Serie	34.0
7: 4.4 →		
8: *10.4 ↓	Total	237.0
9: 6.2 →		
10: 7.7 ↑		

1: 7.8 ↑	Serie	32.0
2: 5.3 ↓		
3: 8.3 ↗	Total	269.0
4: 6.1 →		
5: 6.8 ←		

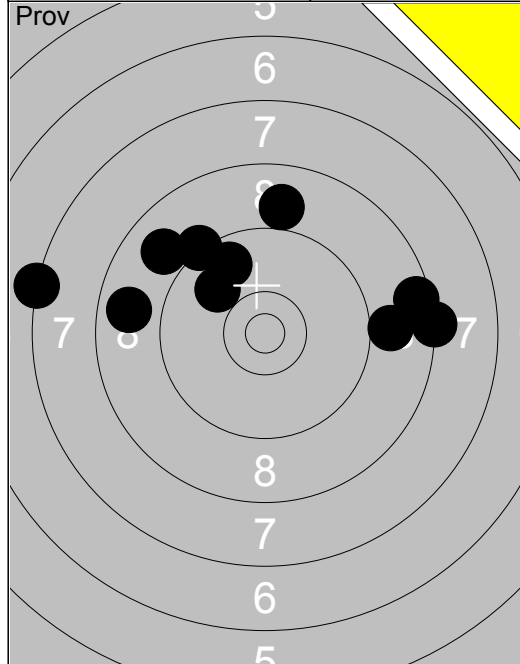

1:	8.8	←
2:	9.3	↗
3:	7.3	←
4:	8.9	↗
5:	9.7	↗
6:	9.9	↗
7:	9.0	↑
8:	9.0	→
9:	8.3	→
10:	8.5	→
Serie		84.0
Total		155.0

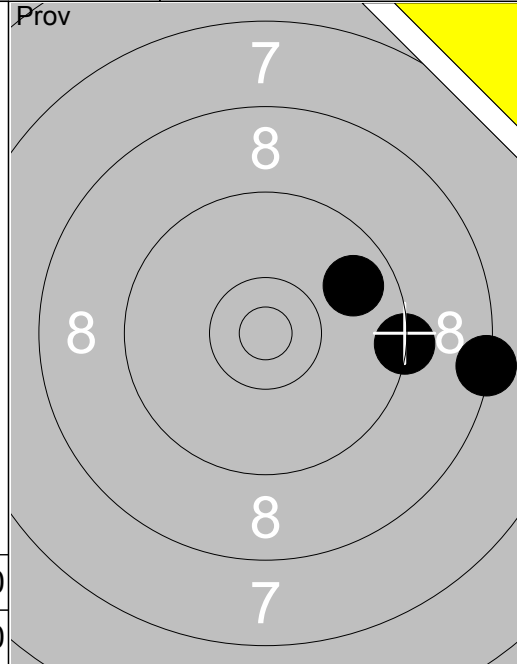

11:	9.8	↗
12:	9.3	→
13:	8.3	→
Serie		26.0
Total		155.0

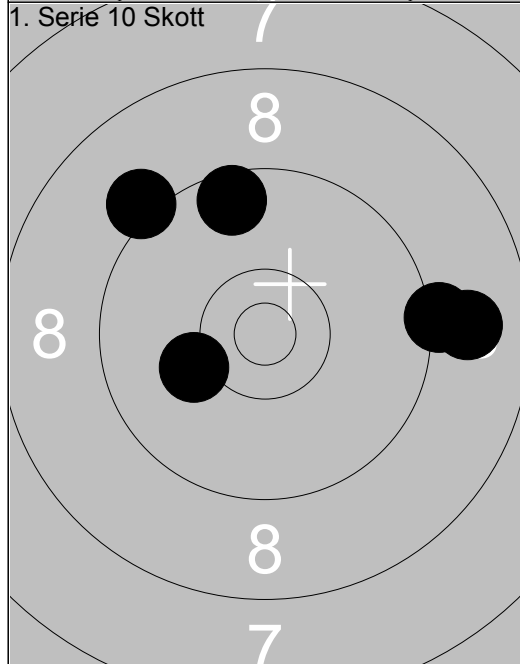

1:	10.2	↙
2:	9.2	↖
3:	9.2	→
4:	8.9	→
5:	9.6	↑
Serie		45.0
Total		200.0

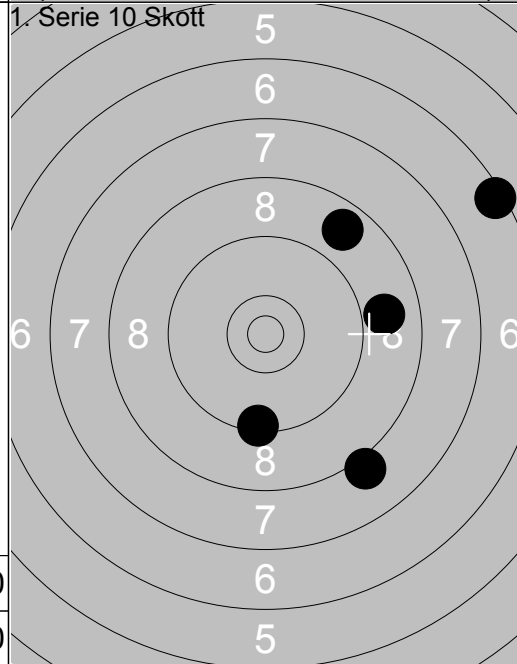

6:	8.1	↘
7:	9.4	↓
8:	6.4	↗
9:	8.8	↗
10:	8.9	→
Serie		39.0
Total		239.0

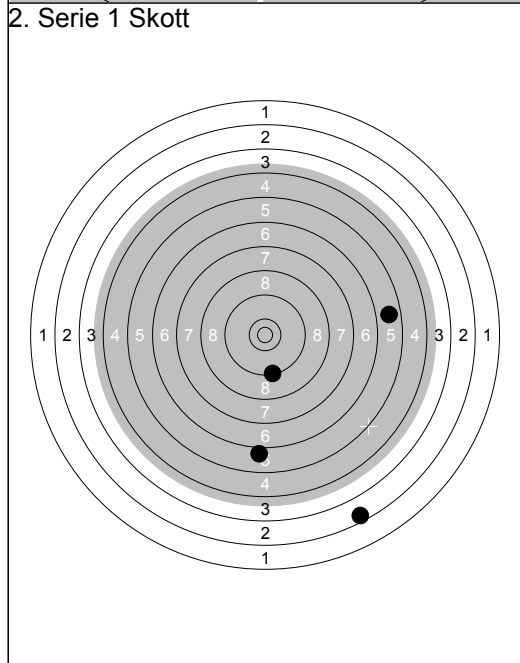

1:	5.8	→
2:	0.0	→
3:	2.5	↘
4:	9.3	↘
5:	6.1	↓
Serie		22.0
Total		261.0