

Skjutlag	Tavla	Hilde Karlsson		
2	2	10m	Ramselefors	DJ Vb
01.03.2014	DM luftgevär 2014-03-01	Ramselefors SKF		
Prov 	1:	8.3	↘	
	2:	8.5	↘	
	3:	9.9	↘	
	4:	9.1	→	
	5:	*10.8	↘	
	6:	*10.2	↘	
	7:	9.0	↙	
	8:	10.1	↘	
	9:	10.1	↘	
	Serie			86.0
Total			0.0	
40 Skott 	1:	*10.3	←	
	2:	9.8	←	
	3:	9.7	↘	
	4:	*10.3	↘	
	5:	*10.6	↘	
	6:	*10.6	↗	
	7:	8.3	→	
	8:	9.5	↘	
	9:	*10.6	↗	
	10:	9.6	↗	
Serie			99.3	
Total			99.3	
40 Skott 	11:	*10.5	←	
	12:	*10.2	←	
	13:	10.0	↘	
	14:	9.9	←	
	15:	*10.5	←	
	16:	9.5	↘	
	17:	*10.7	↙	
	18:	*10.7	↗	
	19:	*10.5	↗	
	20:	*10.3	→	
Serie			102.8	
Total			202.1	

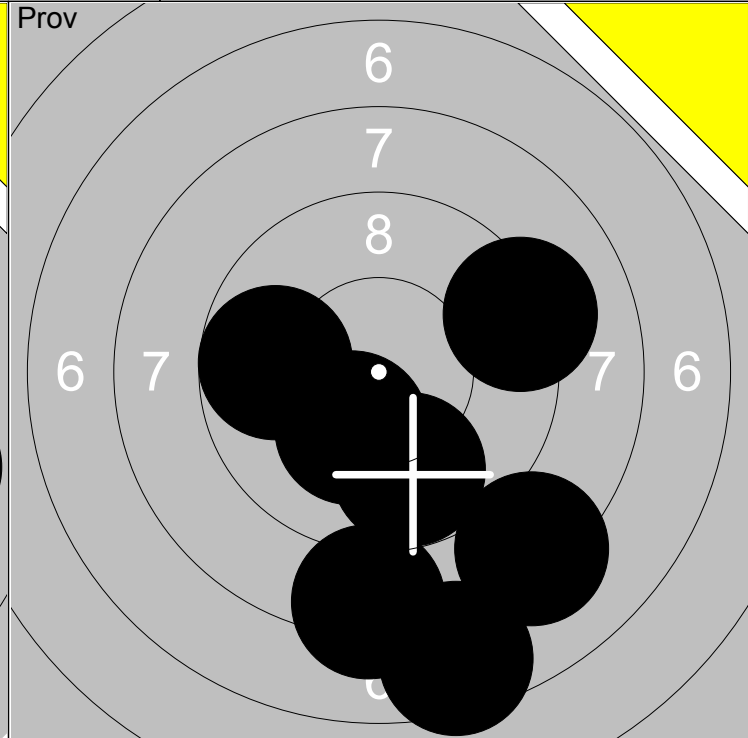

1: 8.4 ↗	6: 9.0 ↓	Serie	89.8
2: 9.5 ↗	7: 7.4 →		
3: 9.7 ↗	8: 8.1 →	Total	0.0
4: 10.1 ↓	9: 9.1 ↙		
5: 8.3 →	10: *10.2 ↘		

11: 8.3 ↓	16: 8.2 ↓	Serie	62.9
12: 9.7 ←	17: 9.2 →		
13: 7.5 ↓		Total	0.0
14: 9.8 ↓			
15: *10.2 ↘			

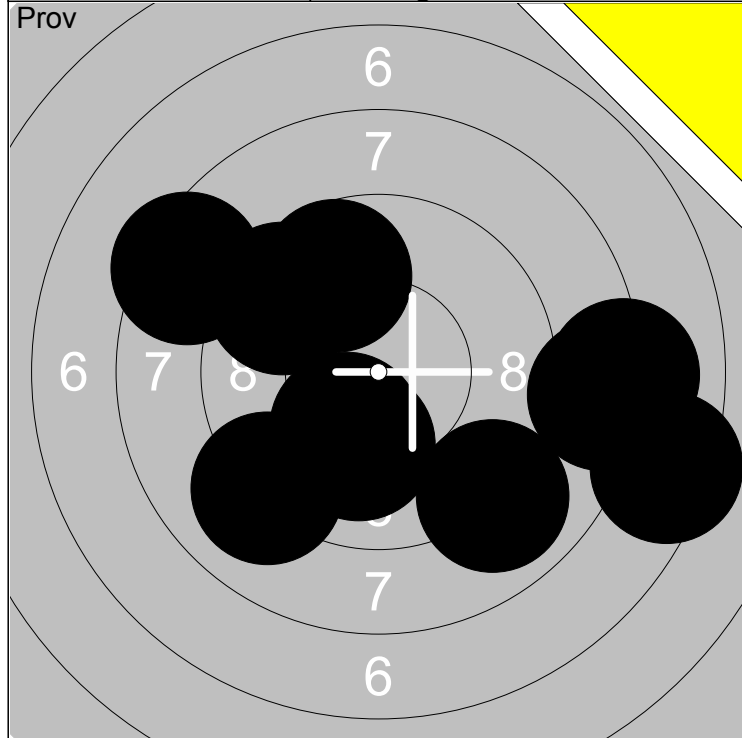
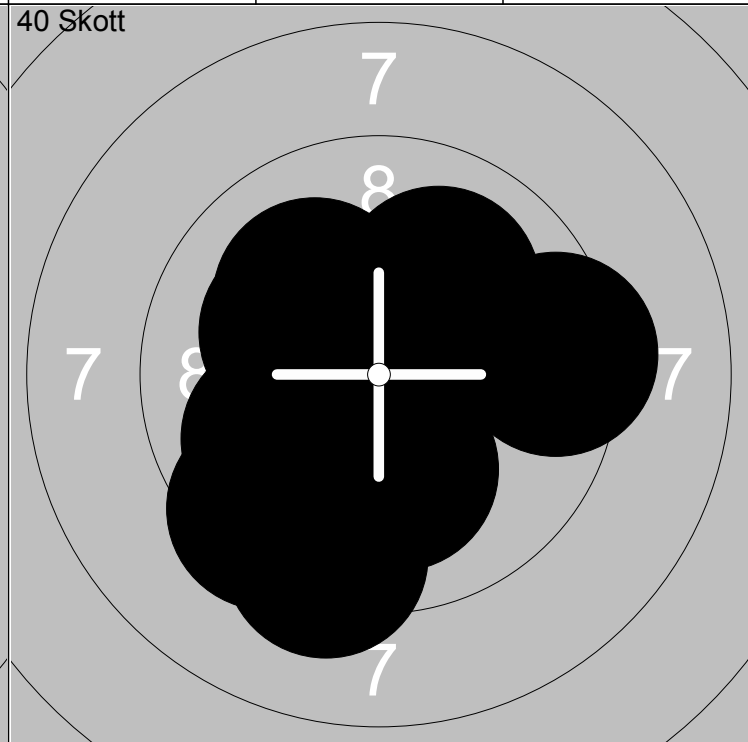
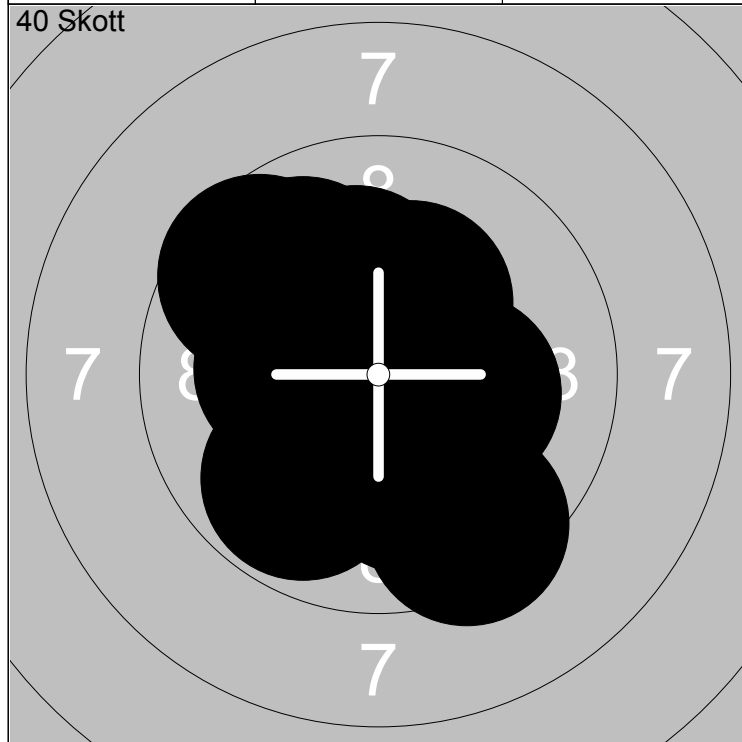

1: 9.4 ↓	6: 9.9 ↗	Serie	100.1
2: 10.1 ↓	7: *10.2 →		
3: 9.6 ↗	8: *10.4 →	Total	100.1
4: *10.2 ↗	9: 9.8 ↓		
5: *10.3 ↗	10: *10.2 ←		

11: *10.2 ↗	16: *10.6 ↗	Serie	99.0
12: 10.0 ↓	17: 10.0 ↗		
13: 10.1 ↗	18: 10.1 ↓	Total	199.1
14: 9.9 ↙	19: 9.4 ↓		
15: 9.4 →	20: 9.3 ↓		

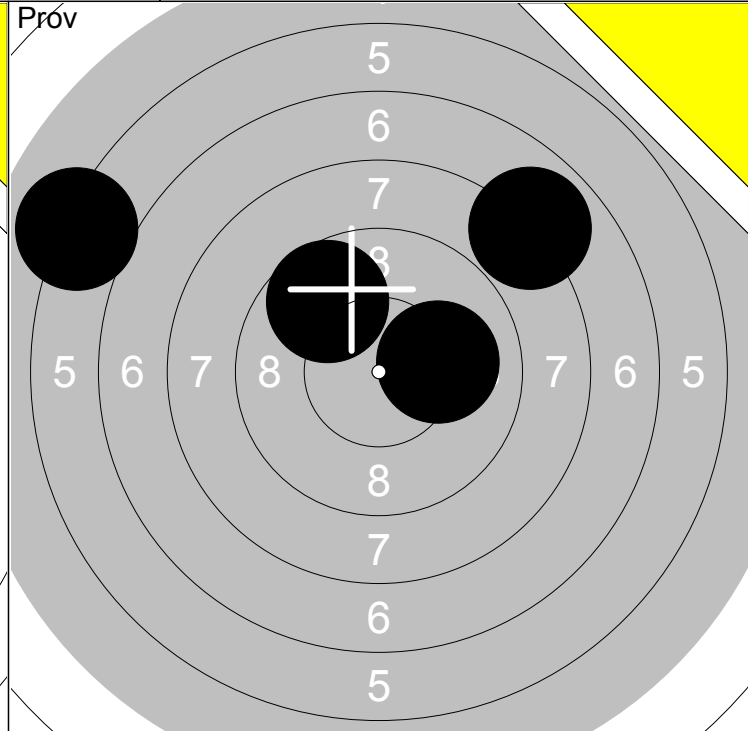
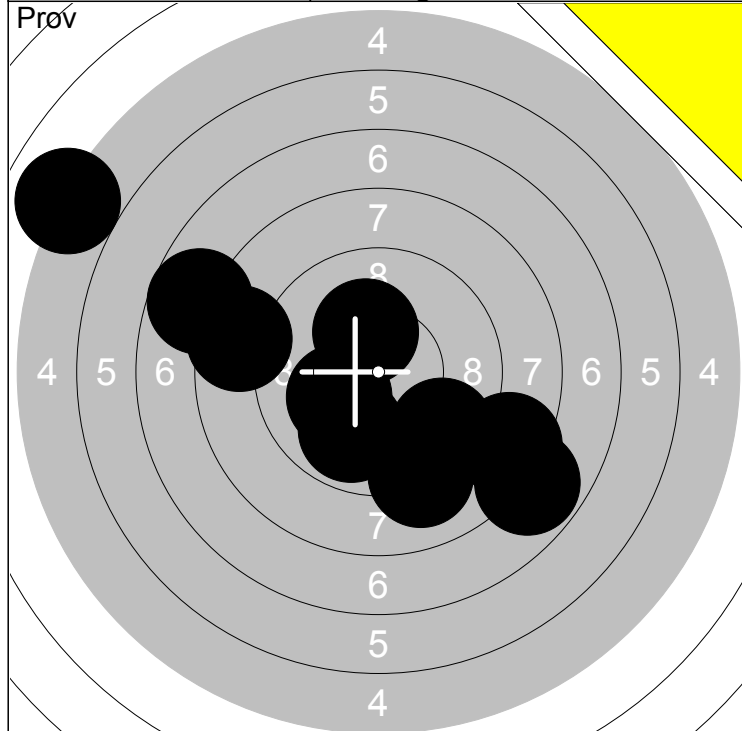

1: 9.9 ↘	6: 7.8 ↘	Serie	86.3
2: *10.2 ↗	7: 9.1 ↘		
3: 8.4 ↘	8: 9.5 ↘	Total	0.0
4: 7.7 ↖	9: *10.2 ↘		
5: 8.5 ↖	10: 5.0 ↖		

11: 7.9 ↗	Serie	33.8
12: 10.1 →		
13: 6.1 ↖	Total	0.0
14: 9.7 ↗		

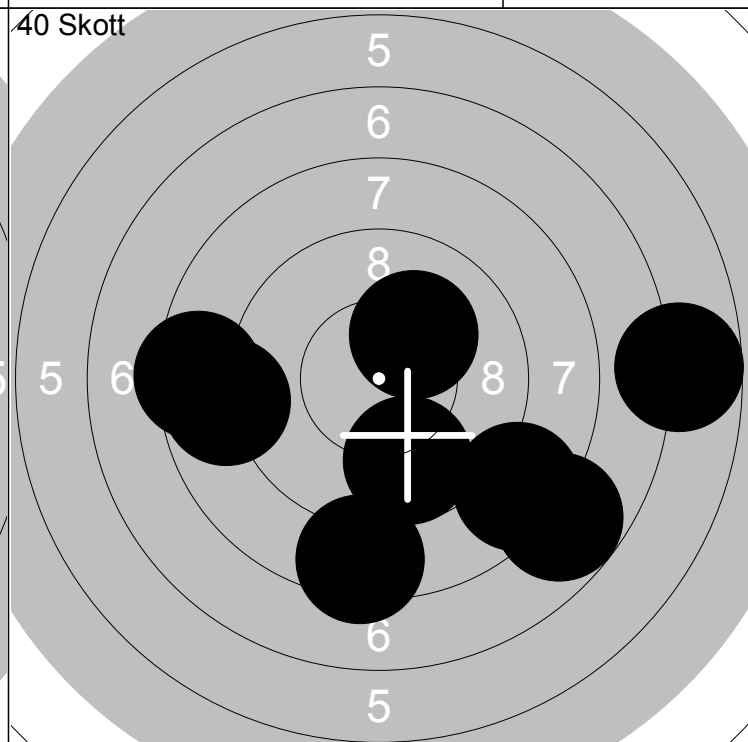
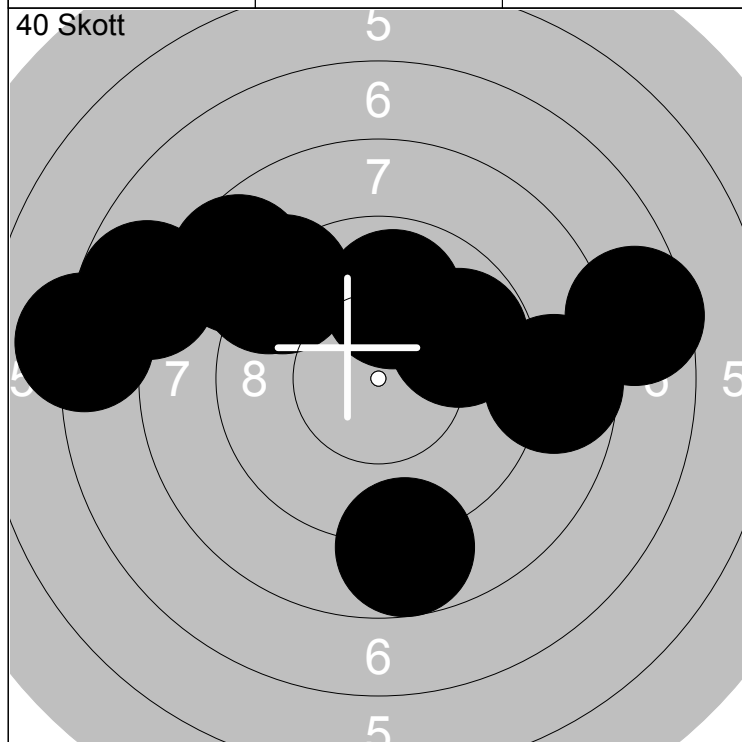

1: 9.9 ↑	6: 9.1 ↗	Serie	86.3
2: 8.7 →	7: 9.8 ↗		
3: 9.2 ↗	8: 8.6 ↖	Total	86.3
4: 7.7 ↖	9: 8.7 ↘		
5: 7.5 →	10: 7.1 ↖		

11: 7.8 ↘	16: 8.4 ↖	Serie	68.5
12: 6.7 →	17: *10.2 ↗		
13: 9.7 ↘	18: 8.8 ↖	Total	154.8
14: 8.4 ↘			
15: 8.5 ↘			

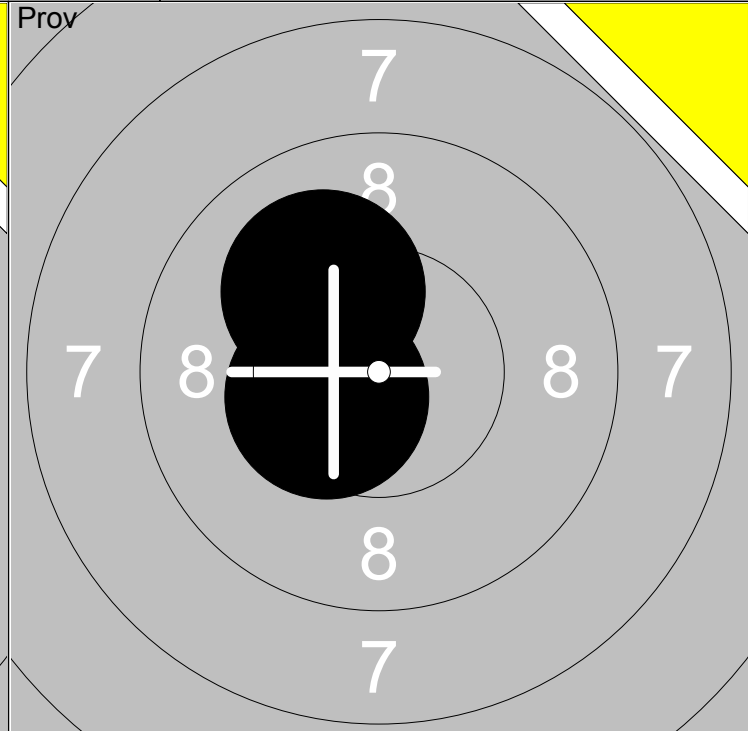

1: 9.8 ↙	6: *10.4↙	Serie	100.3
2: 9.6 ↓	7: 9.8 ↙		
3: *10.8↗	8: 9.3 ↙	Total	0.0
4: *10.3↗	9: 10.1 ↗		
5: 9.8 ↙	10: *10.4↗		

11: 10.1 ↗	Serie	20.5
12: *10.4↙		
Total		0.0

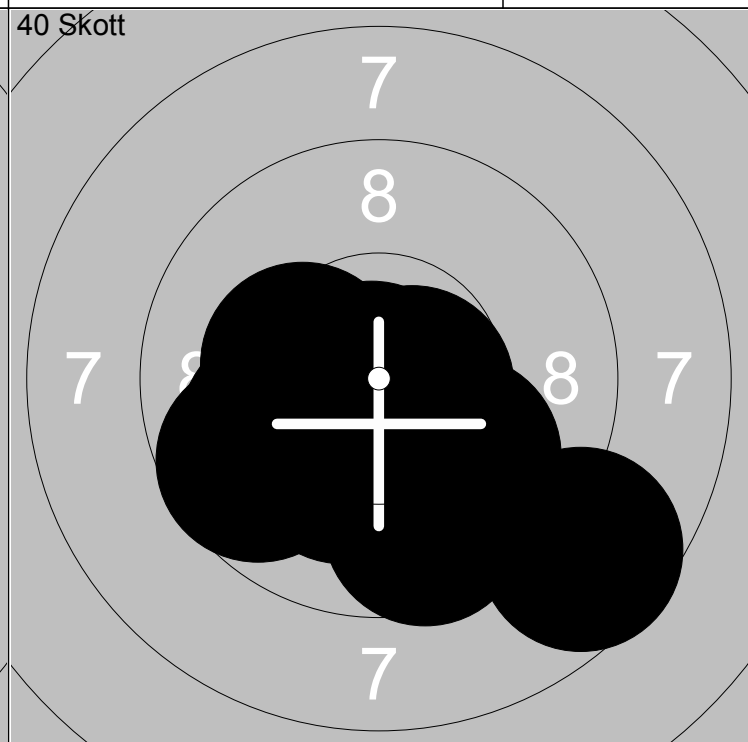
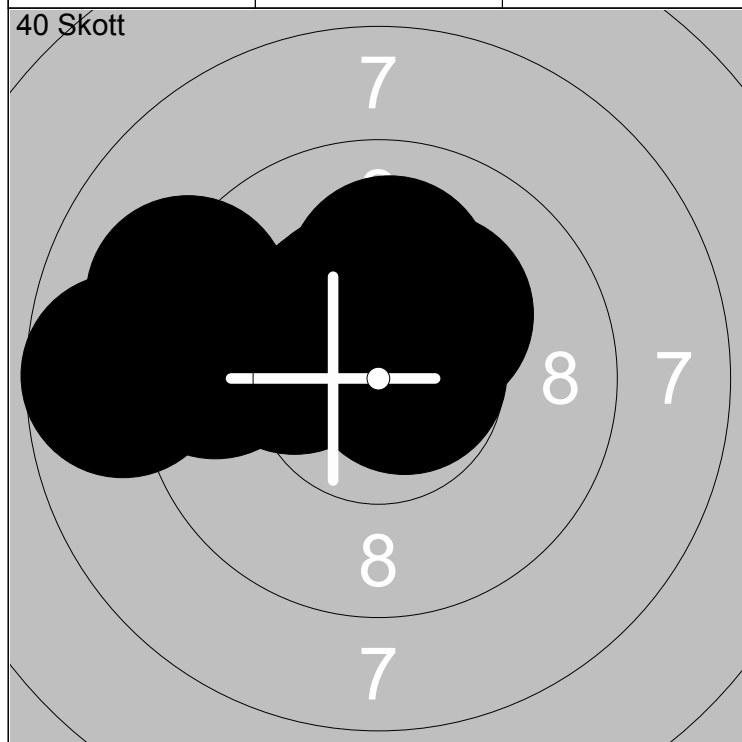

1: *10.7→	6: *10.2↗	Serie	99.9
2: *10.7→	7: 8.7 ↙		
3: *10.3↗	8: 10.1 ↑	Total	99.9
4: *10.4↗	9: 9.5 ↙		
5: *10.2↙	10: 9.1 ↙		

11: *10.9↙	16: *10.4↓	Serie	100.3
12: 9.7 ↙	17: 8.6 ↘		
13: 10.0 ↘	18: *10.2↓	Total	200.2
14: *10.3↙	19: 9.6 ↓		
15: 10.0 ↙	20: *10.6→		

Skjutlag 2	Tavla 6	Monica Häggström		
----------------------	-------------------	-------------------------	--	--

10m	Ramselefors	D	Vb
-----	-------------	---	----

01.03.2014	DM luftgevär 2014-03-01	Ramselefors SKF
------------	-------------------------	-----------------

Prov 	1:	9.2	↓
	2:	9.9	←
	3:	9.8	↘
	4:	*10.6	↗
	5:	8.6	→
	6:	8.9	↗
	7:	10.1	↗
	8:	10.0	↗
	9:	9.9	↖
	10:	*10.4	↗
	Serie		97.4
Total		0.0	

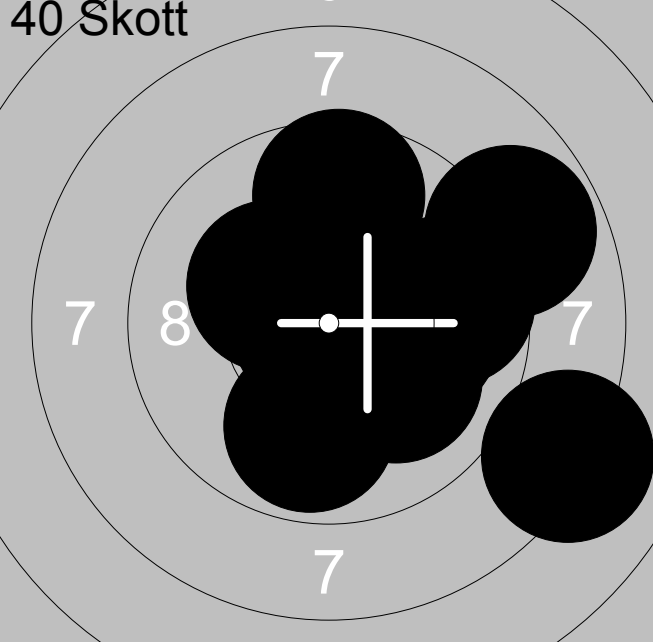
40 Skott 	1:	*10.8	↖
	2:	*10.3	↓
	3:	8.1	↘
	4:	10.1	↘
	5:	9.7	→
	6:	8.8	↗
	7:	10.1	→
	8:	9.9	↓
	9:	*10.2	↖
	10:	9.6	↑
	Serie		97.6
Total		97.6	

40 Skott 	11:	9.7	↖
	12:	9.6	↖
	13:	9.8	→
	14:	9.9	↗
	15:	10.0	↗
	16:	*10.9	←
	17:	9.9	↑
	18:	10.1	↘
	19:	10.0	→
	20:	*10.6	↑
	Serie		100.5
Total		198.1	

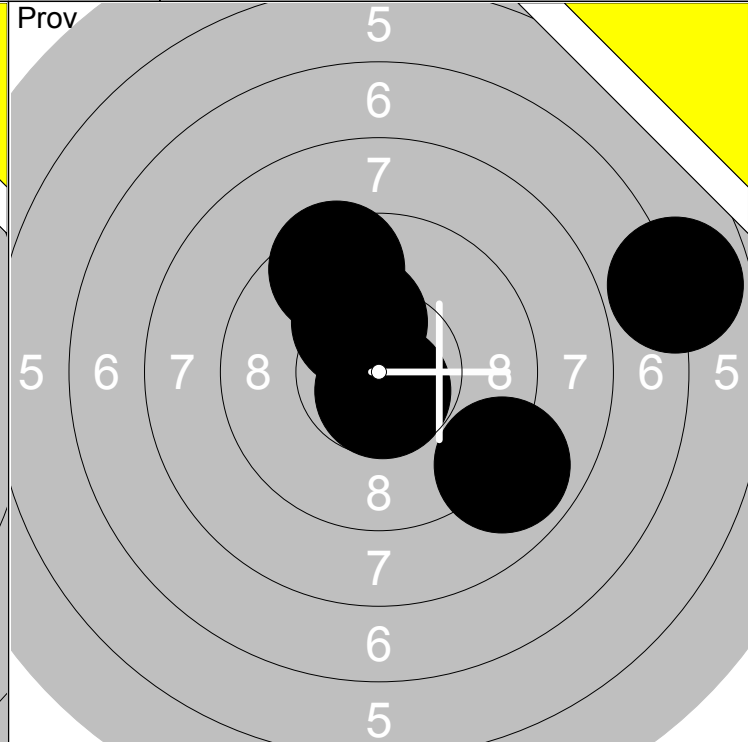
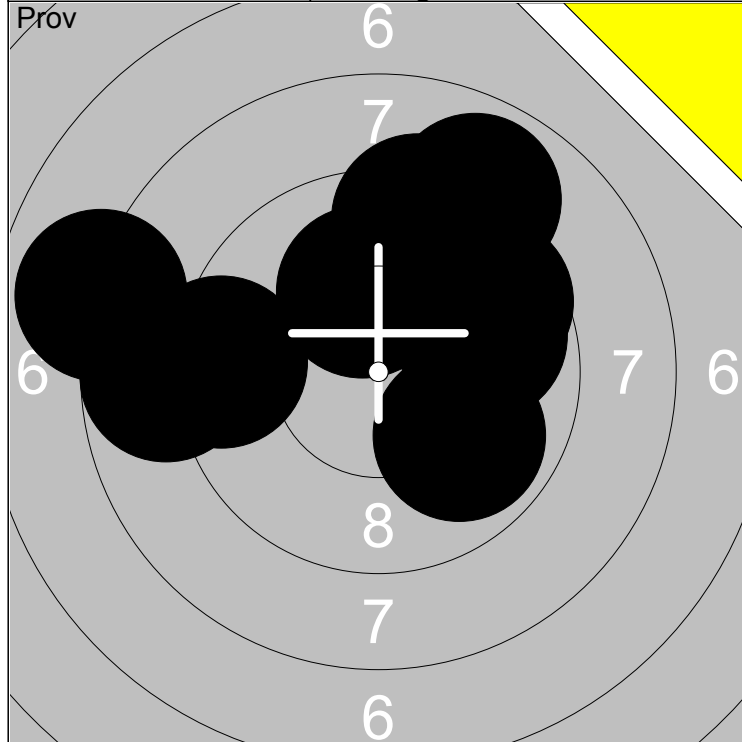

1: 8.7 ←	6: 9.3 ↑	Serie	93.4
2: 9.8 →	7: 8.9 ↗		
3: 10.1 ↑	8: 8.0 ←	Total	0.0
4: 9.6 ↗	9: 9.9 ↘		
5: 9.3 ←	10: 9.8 →		

11: 6.9 →	Serie	46.2
12: 9.5 ↑		
13: *10.2 ↗	Total	0.0
14: 8.9 ↘		
15: *10.7 ↓		

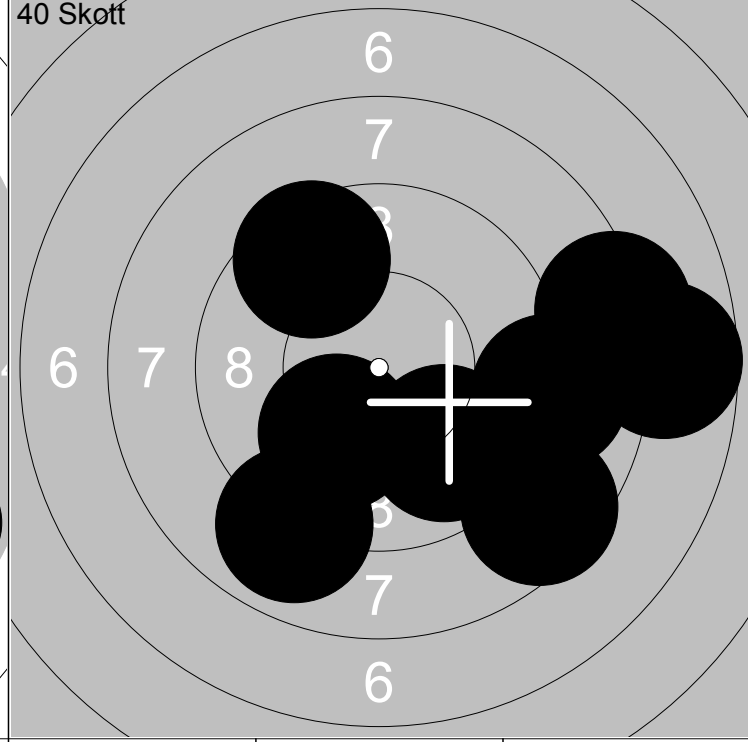
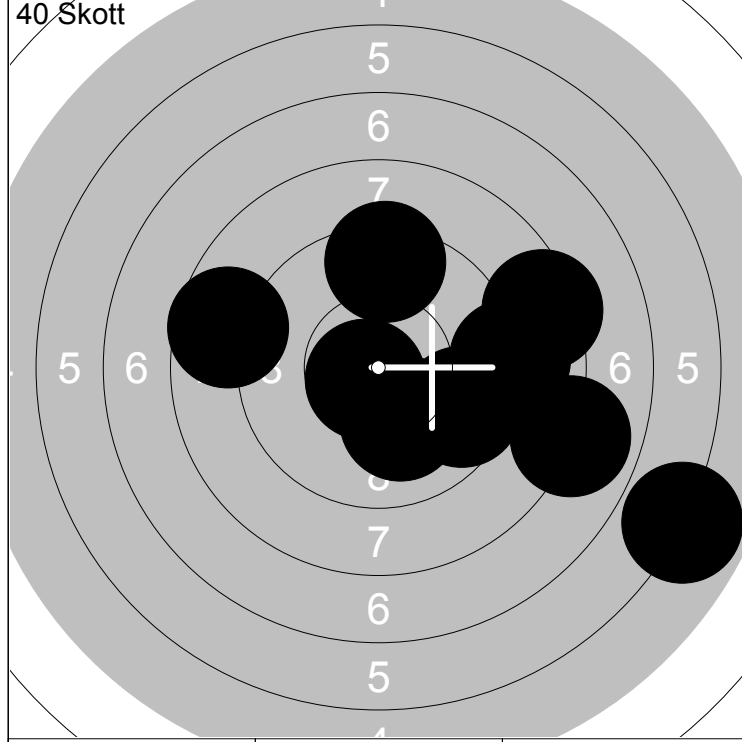

1: 10.1 ↓	6: 7.9 →	Serie	89.7
2: 5.9 ↘	7: 10.1 ↓		
3: 9.6 →	8: 9.0 →	Total	89.7
4: 8.6 ←	9: *10.7 ↘		
5: 9.4 ↑	10: 8.4 →		

11: 8.5 ↘	16: 10.1 ↓	Serie	71.7
12: 7.7 →	17: 9.8 ↘		
13: 9.0 →	18: 9.5 ↑	Total	161.4
14: 8.2 →			
15: 8.9 ↓			

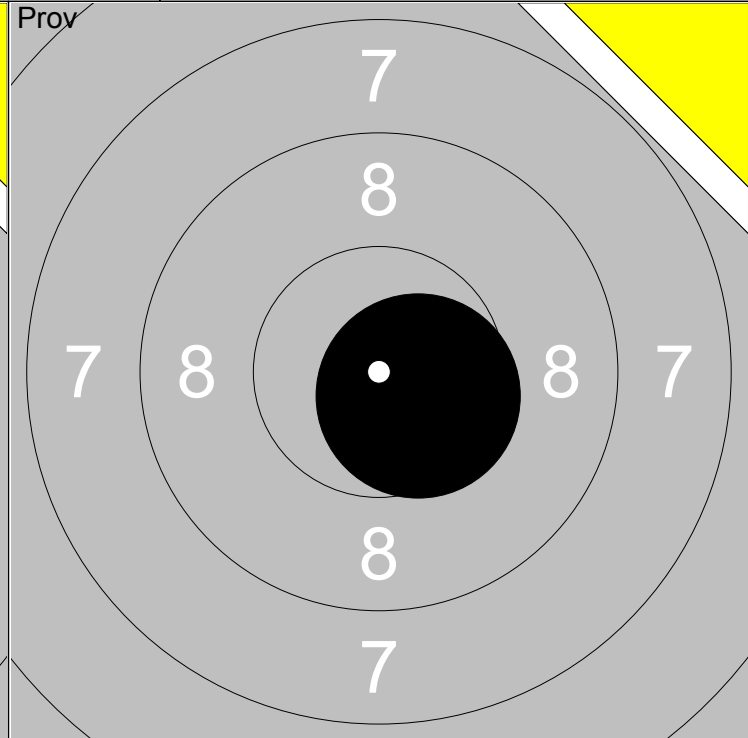
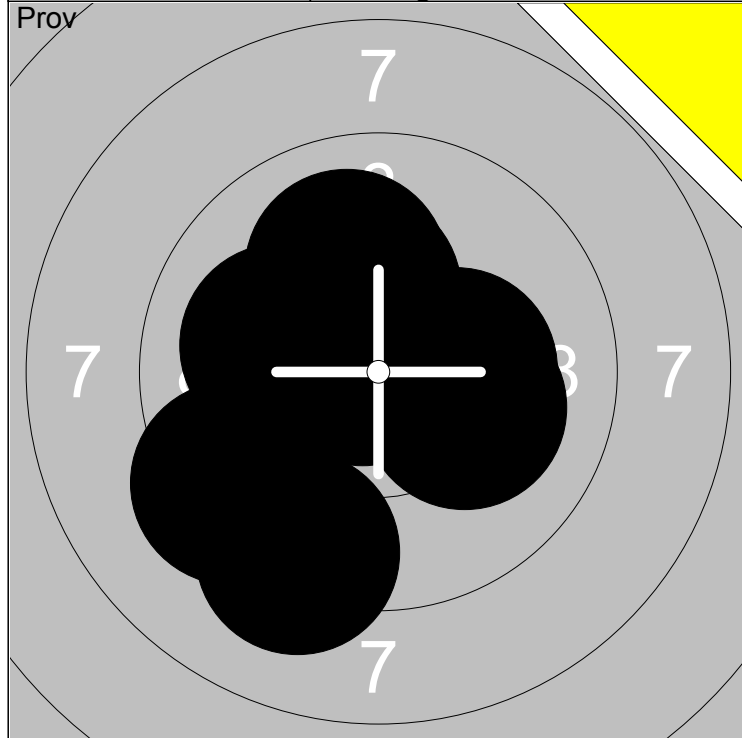

1: 9.3 ↙	6: *10.6 →	Serie	101.0
2: 9.2 ↘	7: 10.1 →		
3: *10.3 →	8: 10.0 ↗	Total	0.0
4: *10.4 ↗	9: 10.1 ↖		
5: *10.8 ↘	10: *10.2 ↗		

11: *10.5 ↘	Serie	10.5
	Total	0.0

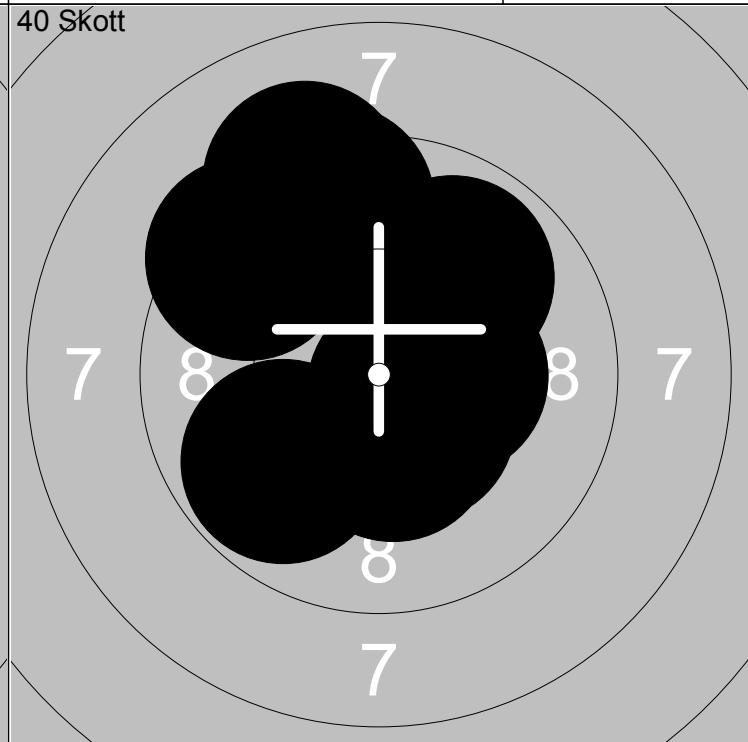
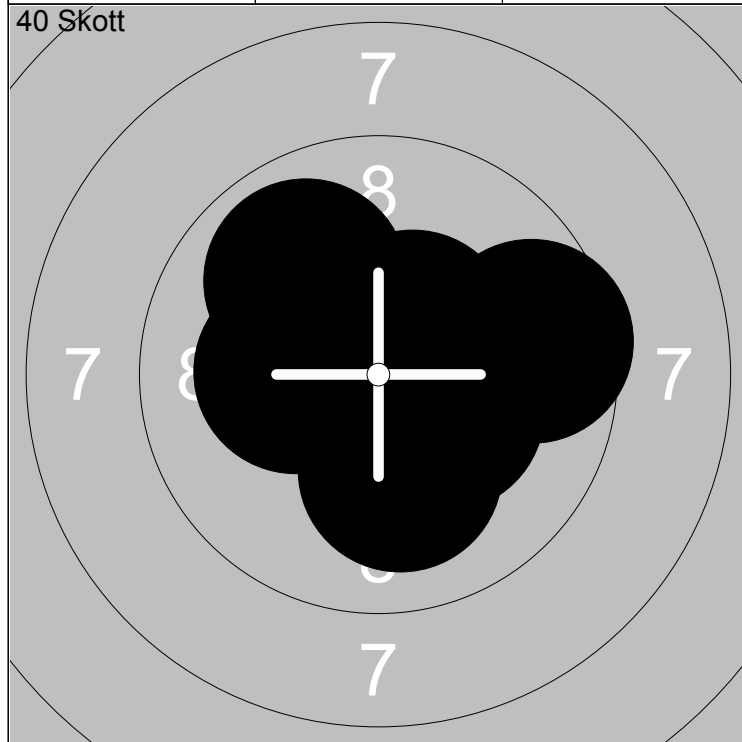

1: *10.5 ↘	6: 10.1 ↘	Serie	102.4
2: *10.5 ↗	7: *10.2 ↖		
3: *10.6 ↘	8: 9.6 →	Total	102.4
4: *10.4 ↘	9: 9.9 ↗		
5: *10.3 ↘	10: *10.3 →		

11: *10.4 →	16: 9.1 ↗	Serie	98.9
12: 9.8 ↙	17: *10.6 →		
13: 9.4 ↗	18: 9.9 ↗	Total	201.3
14: 9.5 ↗	19: *10.4 ↘		
15: *10.4 ↘	20: 9.4 ↖		

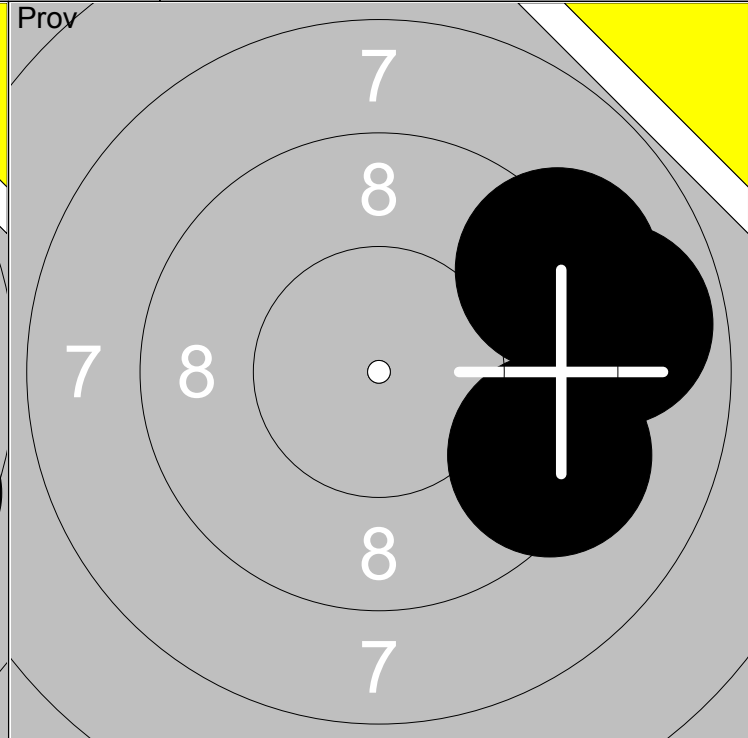
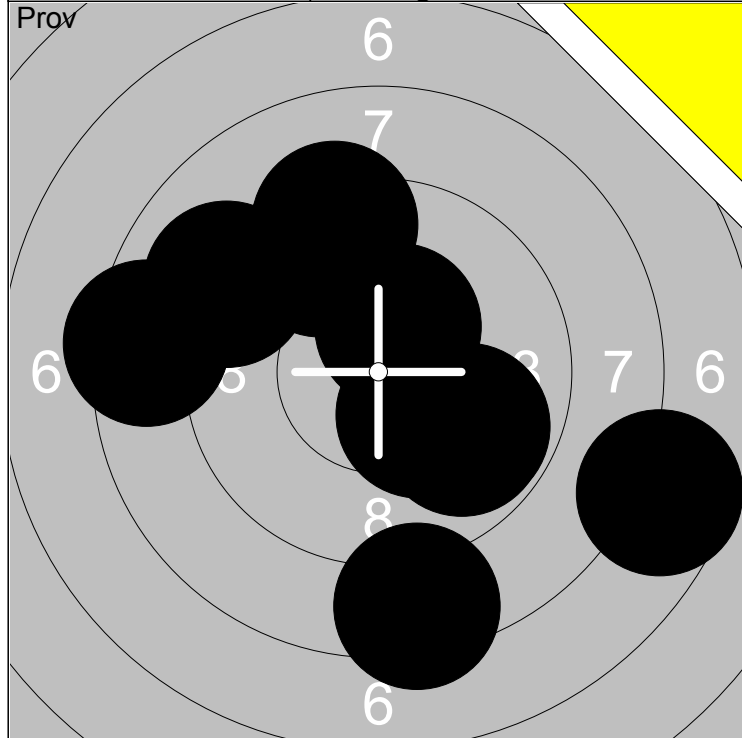

1: 8.4 ←	6: 8.4 ↓	Serie	92.5
2: 9.5 ↗	7: 9.8 ↘		
3: 9.0 ↖	8: *10.3 ↘	Total	0.0
4: 9.3 ↗	9: *10.4 ↗		
5: 9.8 ↘	10: 7.6 ↘		

11: 9.3 →	Serie	27.3
12: 8.9 →		
13: 9.1 ↗	Total	0.0

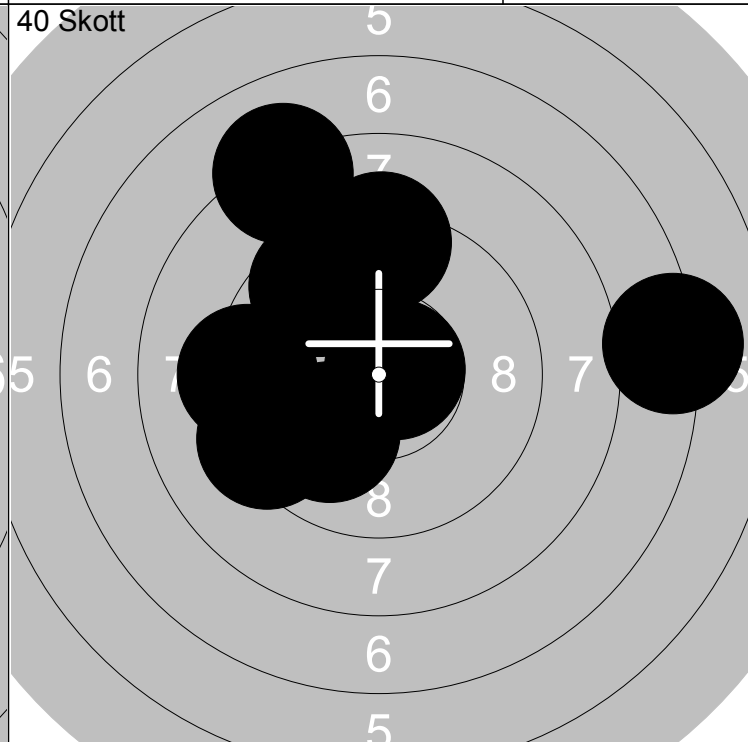
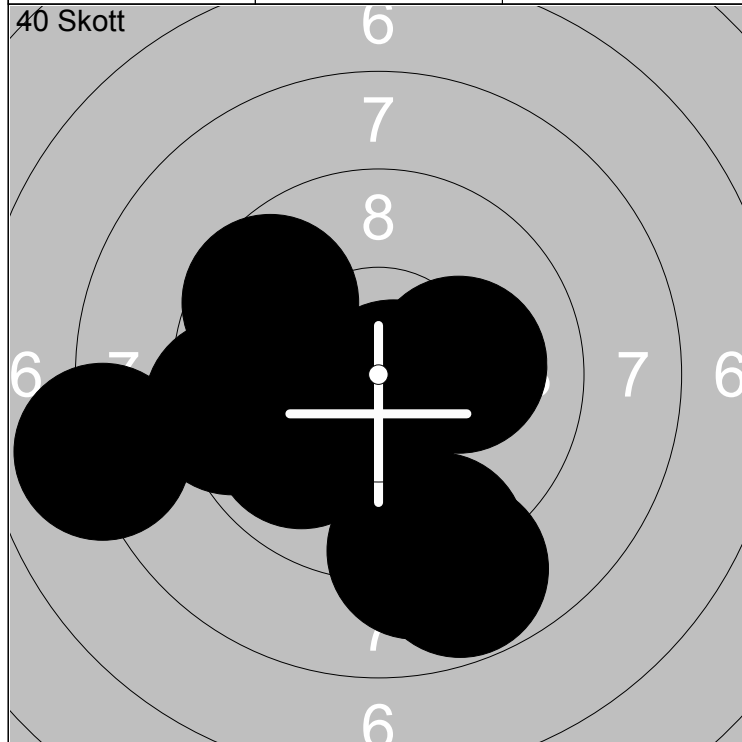

1: 9.1 ↓	6: 9.1 ↓	Serie	95.1
2: 8.0 ←	7: 9.6 ↖		
3: 9.9 ↘	8: 8.8 ↓	Total	95.1
4: *10.4 ↘	9: 9.4 ←		
5: *10.7 ↘	10: 10.1 →		

11: 9.3 ←	16: 10.0 ↘	Serie	73.3
12: 8.1 ↗	17: 9.6 ↖		
13: 9.2 ↑	18: *10.7 →	Total	168.4
14: 7.1 →			
15: 9.3 ↘			

Skjutlag 2	Tavla 11	Anton Lundin		
----------------------	--------------------	---------------------	--	--

10m	Umeå	HJ	Vb
-----	------	----	----

01.03.2014	DM luftgevär 2014-03-01	Ramselefors SKF
------------	-------------------------	-----------------



1:	9.1	↗
2:	8.6	→
3:	8.9	↖
4:	9.4	↙
5:	*10.5	↘
6:	9.6	↘
7:	*10.2	↓
8:	9.2	↗
9:	7.8	→
10:	9.2	↗

Serie	92.5
Total	0.0

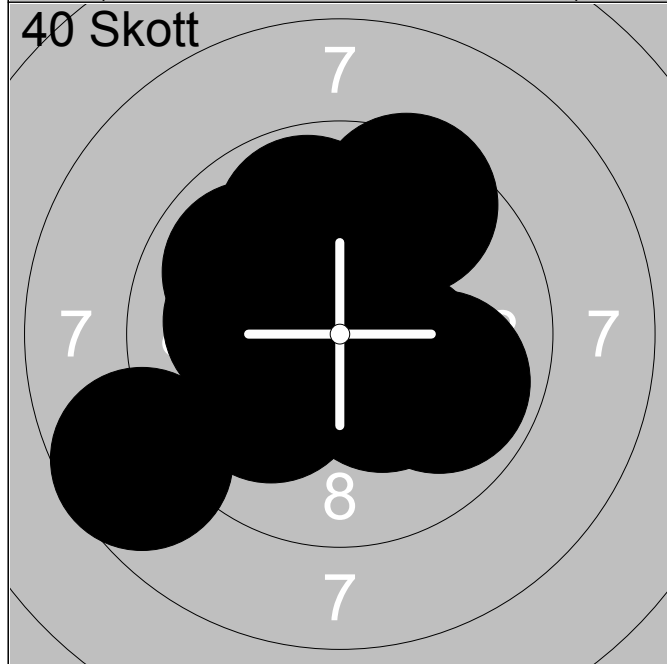

1:	*10.3	↘
2:	10.1	↖
3:	9.5	↗
4:	9.9	↘
5:	8.6	↙
6:	9.8	↗
7:	*10.3	↘
8:	10.0	↗
9:	9.9	↗
10:	10.1	↙

Serie	98.5
Total	98.5

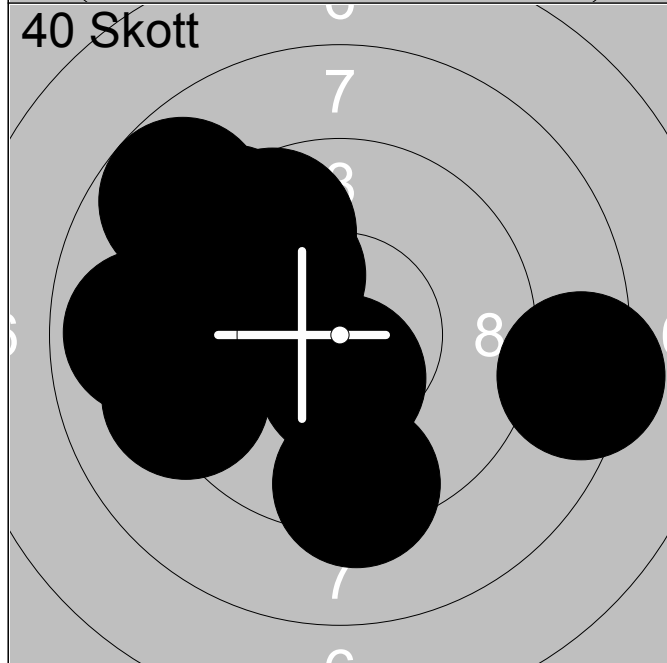

11:	8.3	→
12:	*10.5	↓
13:	9.2	↖
14:	9.4	↓
15:	8.9	↖
16:	9.3	↗
17:	8.7	↗
18:	10.1	↗
19:	9.6	↗
20:	9.3	↖

Serie	93.3
Total	191.8

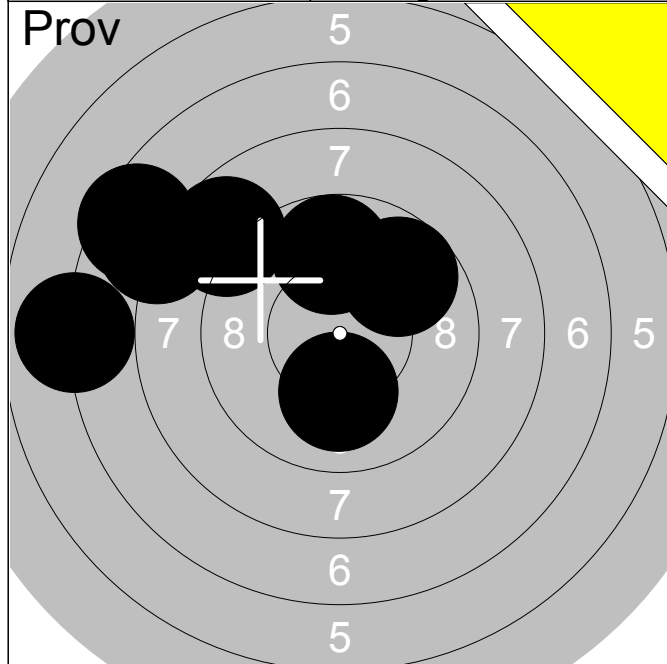

	1:	6.9	←
	2:	9.7	↗
	3:	7.9	↖
	4:	7.5	↖
	5:	9.8	↑
	6:	10.1	↓
	7:	8.7	↖
Serie			60.6
Total			0.0

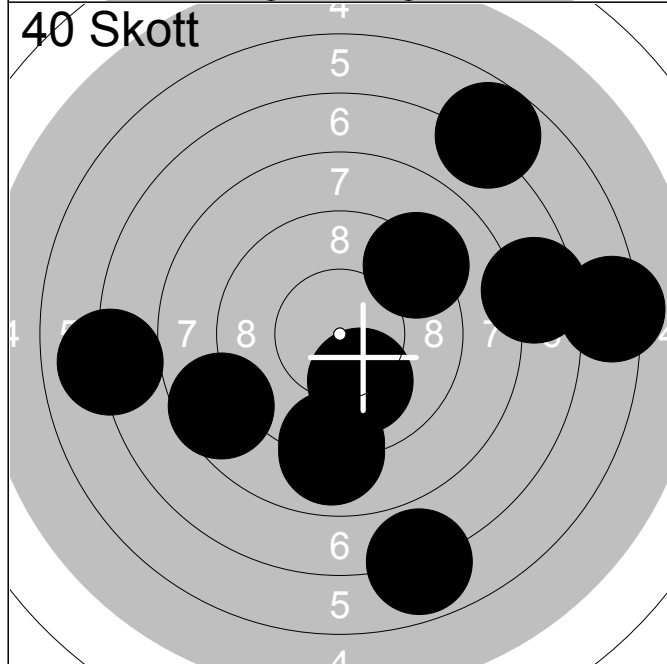

	1:	6.9	↓
	2:	7.0	←
	3:	8.9	↓
	4:	9.1	↓
	5:	6.7	↗
	6:	9.2	↗
	7:	6.3	→
	8:	8.6	↖
	9:	10.1	↓
	10:	7.6	→
Serie			80.4
Total			80.4

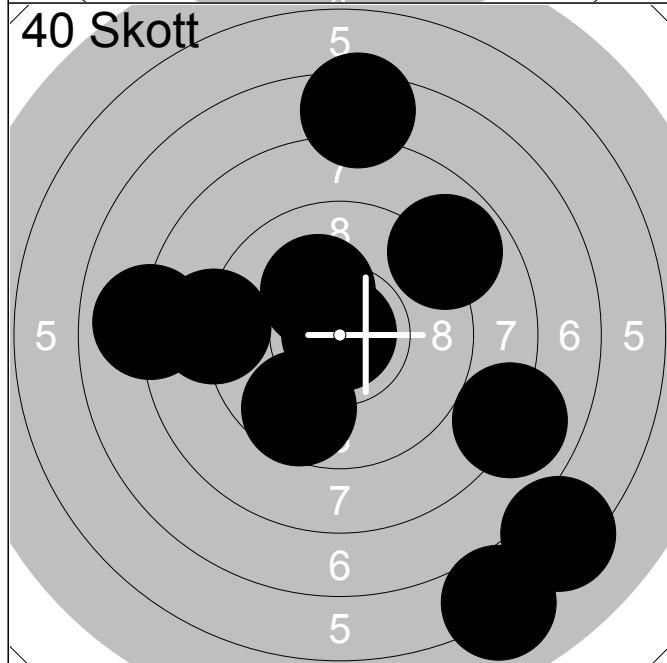

	11:	6.1	↓
	12:	8.0	←
	13:	6.3	↓
	14:	9.0	←
	15:	*10.2	↗
	16:	8.9	↗
	17:	9.6	↖
	18:	8.0	↘
	19:	*10.9	↗
	20:	7.4	↑
Serie			84.4
Total			164.8

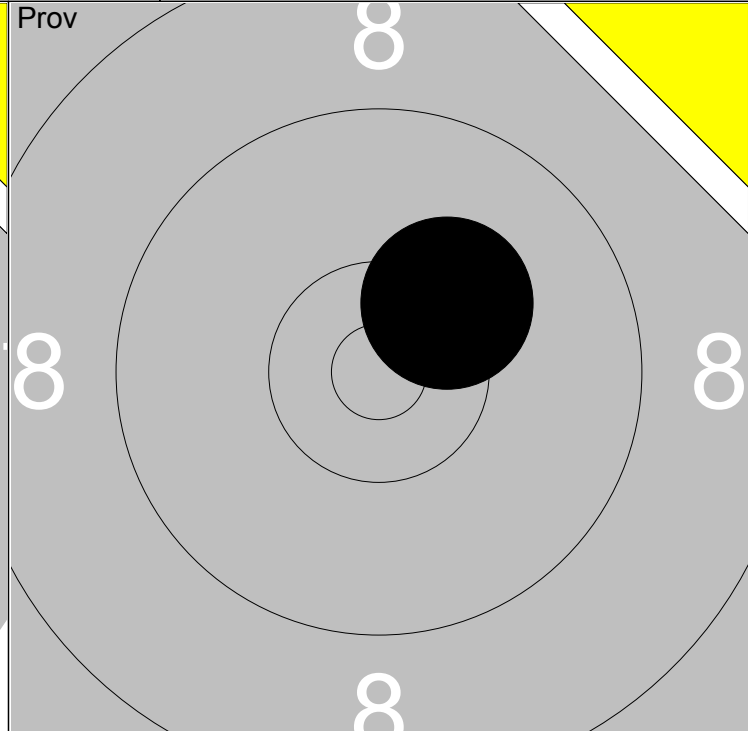
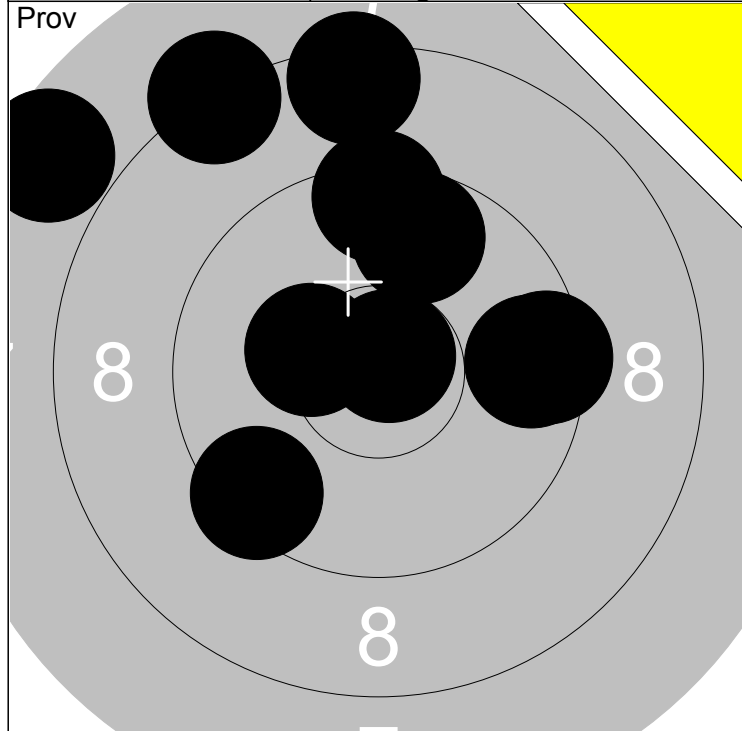

1: 9.7 →	6: 9.8 ↑	Serie	93.6
2: *10.4 ↙	7: 9.5 ↘		
3: *10.8 ↗	8: 9.5 →	Total	0.0
4: 7.6 ↖	9: 8.3 ↖		
5: 8.5 ↑	10: 9.5 ↑		

11: 10.3 ↗	Serie	10.3
	Total	0.0

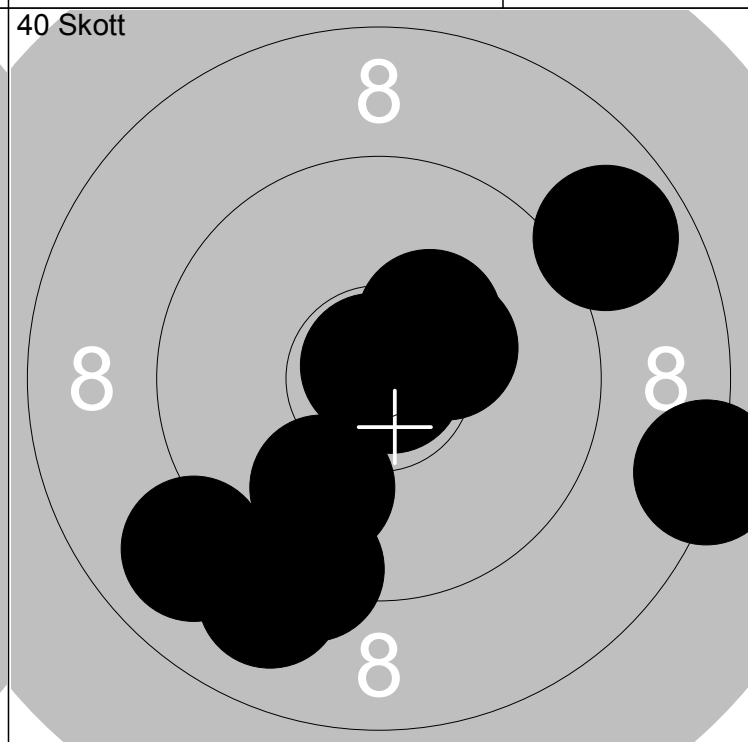
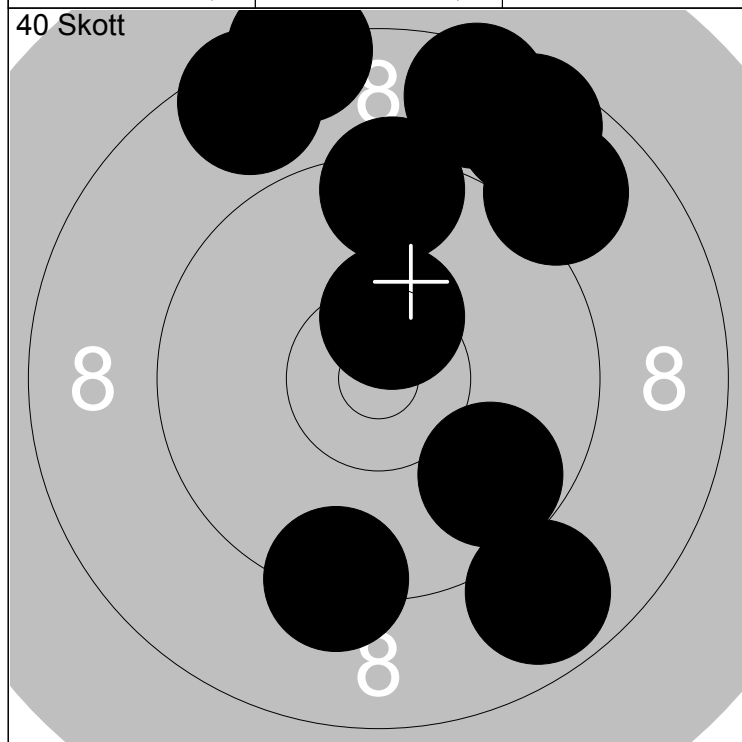

1: *10.5 ↑	6: 8.9 ↘	Serie	91.2
2: 8.9 ↗	7: 8.6 ↑		
3: 8.6 ↖	8: 8.3 ↑	Total	91.2
4: 9.5 ↑	9: 8.7 ↗		
5: 9.8 ↘	10: 9.4 ↓		

11: 9.0 ↖	16: 9.4 ↓	Serie	97.2
12: *10.9 →	17: *10.4 ↗		
13: 9.1 ↓	18: 8.9 ↗	Total	188.4
14: 8.3 →	19: *10.4 ↗		
15: 10.0 ↓	20: *10.8 ↘		

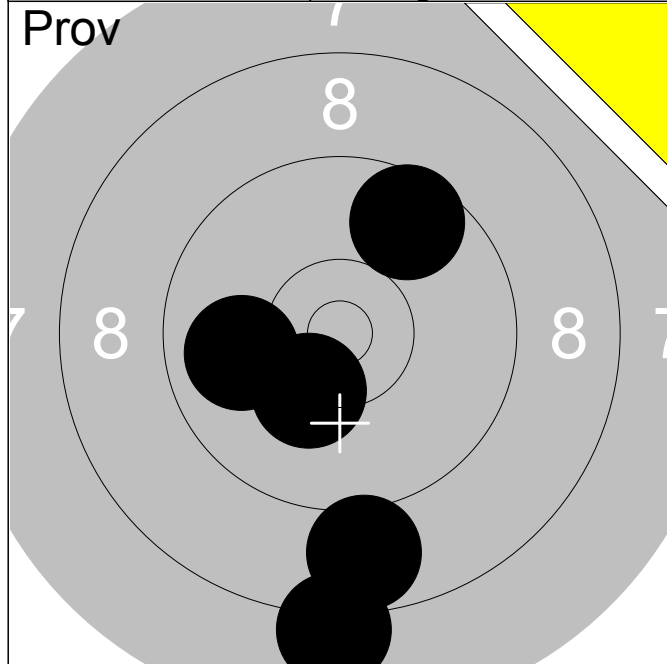

1:	10.3	↙
2:	10.0	←
3:	8.8	↓
4:	9.7	↗
5:	8.1	↓

Serie	46.9
Total	0.0

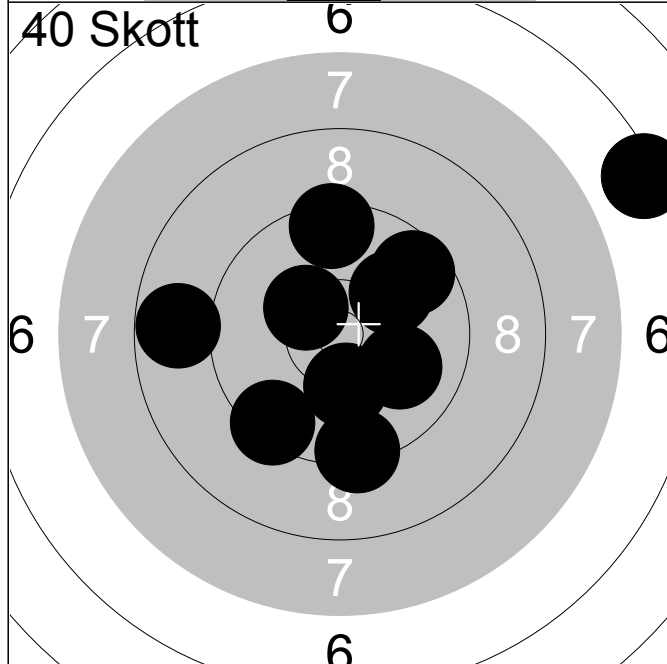

1:	9.5	↙
2:	10.3	↓
3:	8.8	←
4:	10.0	→
5:	10.1	↗
6:	9.7	↗
7:	6.4	→
8:	9.5	↑
9:	9.4	↓
10:	*10.4	↖

Serie	94.1
Total	94.1

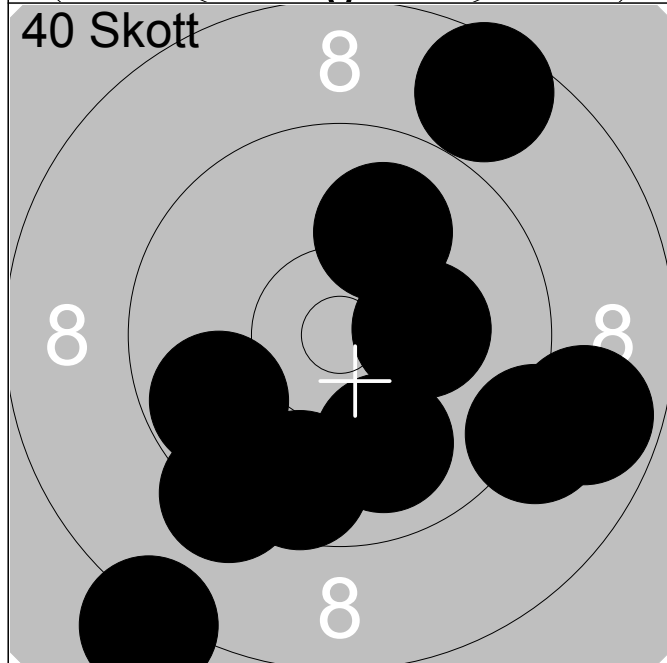

11:	8.7	↗
12:	10.0	↓
13:	9.2	→
14:	10.0	↗
15:	9.4	↙
16:	9.8	←
17:	10.3	→
18:	8.1	↙
19:	8.9	→
20:	9.7	↓

Serie	94.1
Total	188.2

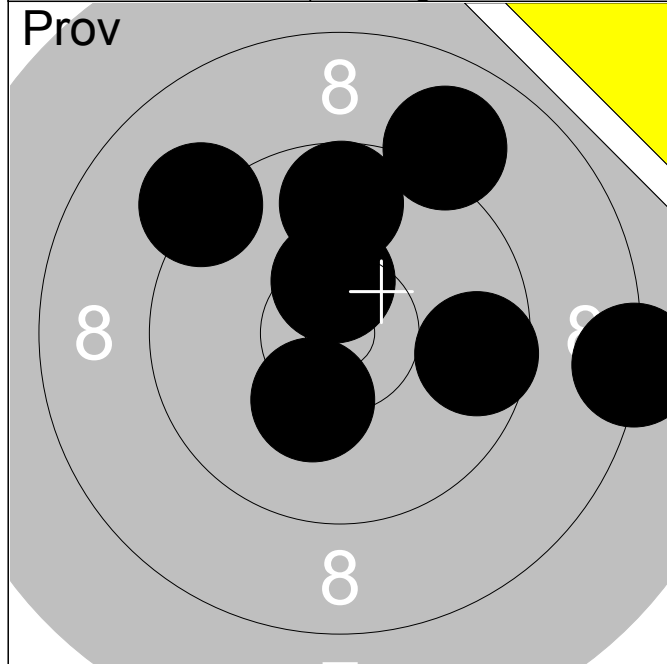

1:	*10.5	↑
2:	9.2	↗
3:	9.7	→
4:	9.8	↑
5:	9.0	↗
6:	10.3	↘
7:	8.3	→
Serie		66.8
Total		0.0

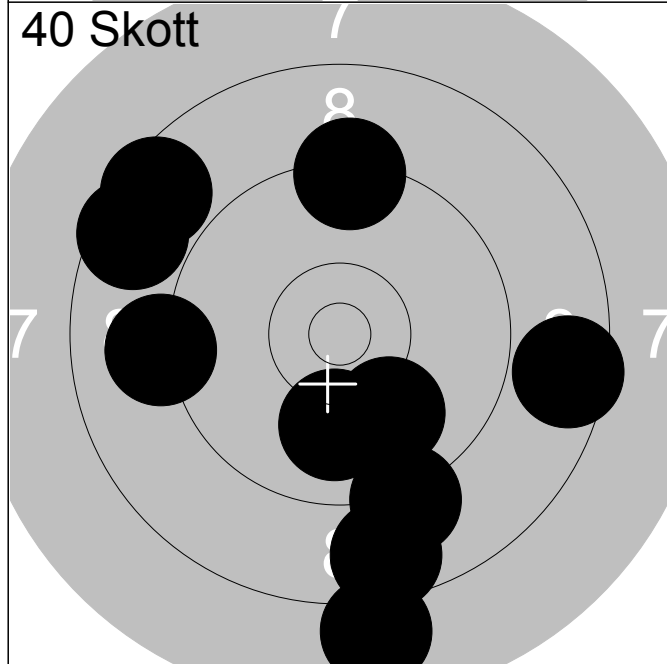

1:	9.2	↘
2:	7.9	↘
3:	10.0	↘
4:	9.3	↑
5:	8.6	→
6:	8.6	↗
7:	8.6	↗
8:	10.0	↘
9:	9.1	←
10:	8.7	↘
Serie		90.0
Total		90.0

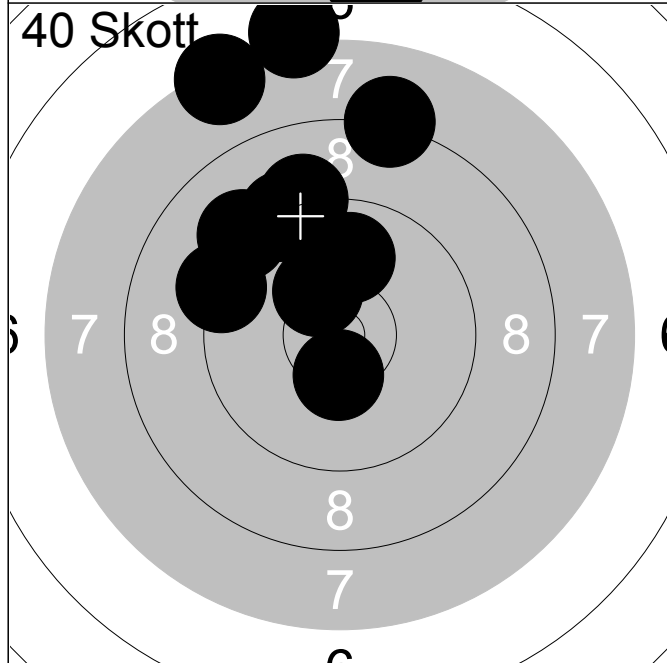

11:	7.4	↗
12:	*10.4	↘
13:	10.3	↗
14:	9.2	↗
15:	9.2	↑
16:	10.0	↑
17:	9.3	↖
18:	7.1	↑
19:	8.2	↑
20:	9.3	↗
Serie		90.4
Total		180.4

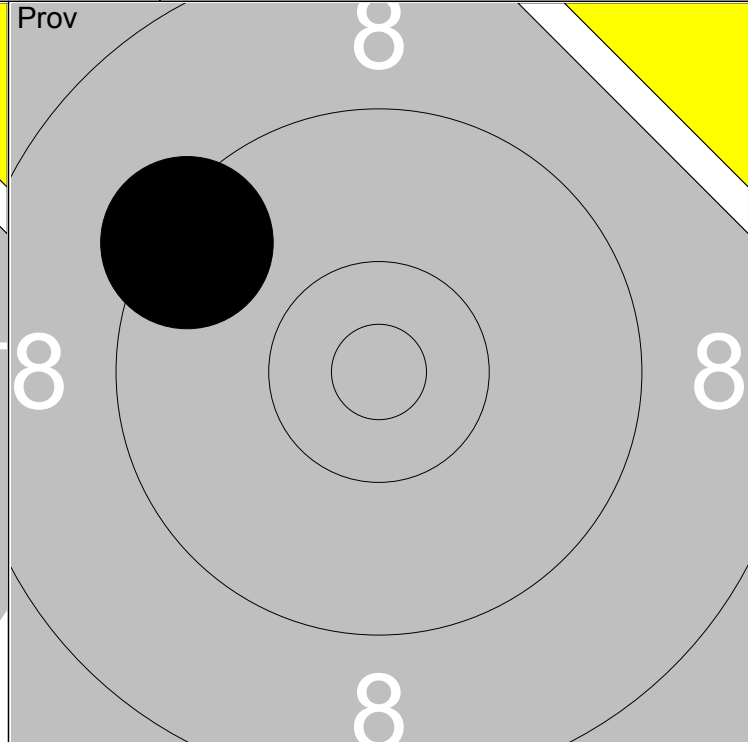
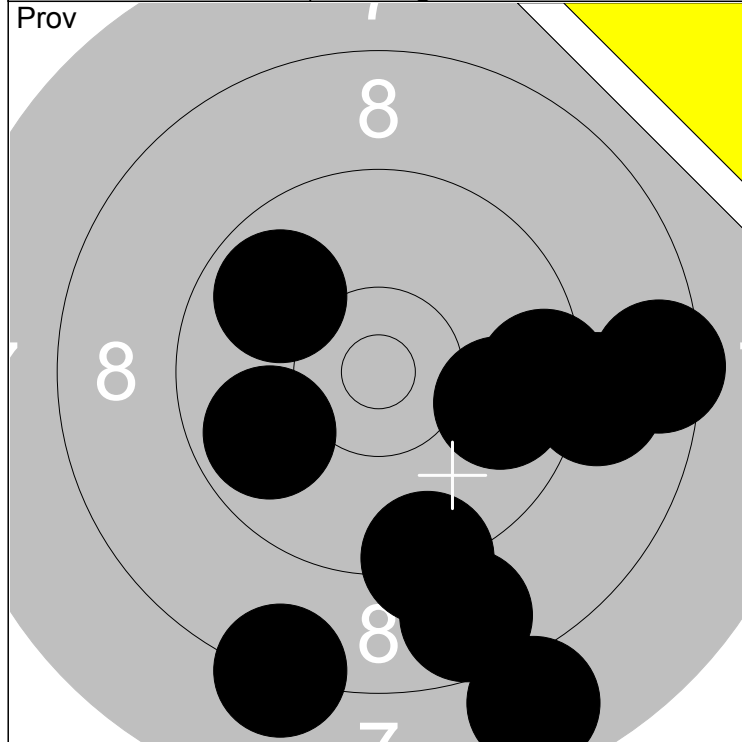

1: 8.3 ↓	6: 9.5 →	Serie	91.2
2: 9.3 ↓	7: 9.9 ↙		
3: 7.9 ↓	8: 9.9 →	Total	0.0
4: 8.6 →	9: 8.8 ↓		
5: 9.9 ↗	10: 9.1 →		

11: 9.4 ↖		Serie	9.4
		Total	0.0

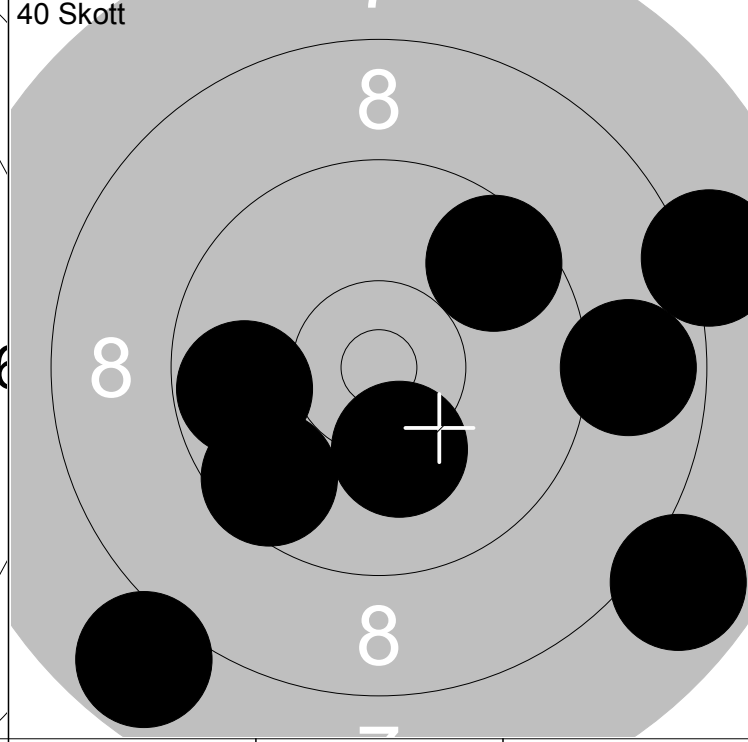
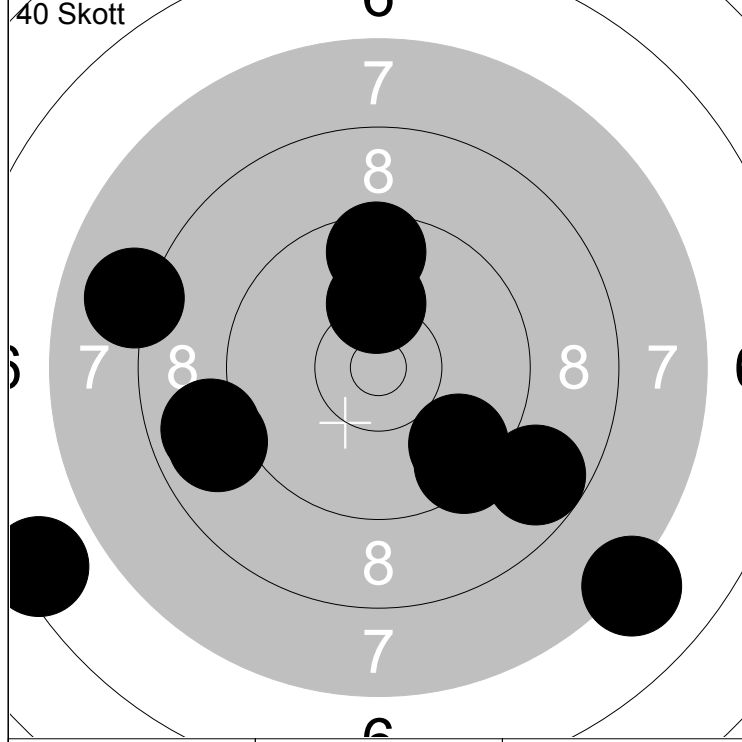

1: 9.6 ↑	6: 9.7 ↓	Serie	87.4
2: 8.9 ↙	7: 8.8 ↓		
3: 8.1 ↖	8: 8.9 ↖	Total	87.4
4: 10.2 ↑	9: 7.2 ↓		
5: 6.5 ↖	10: 9.5 ↓		

11: 7.9 ↘	16: 9.7 ↙	Serie	72.3
12: 9.7 ↗	17: 7.9 ↙		
13: 8.1 →	18: 10.3 ↓	Total	159.7
14: 8.9 →			
15: 9.8 ↖			

Skjutlag 2	Tavla 22	Tomas Backlund		
----------------------	--------------------	-----------------------	--	--

10m	Vännäs	PH	Vb
-----	--------	----	----

01.03.2014	DM luftgevär 2014-03-01	Ramselefors SKF
------------	-------------------------	-----------------

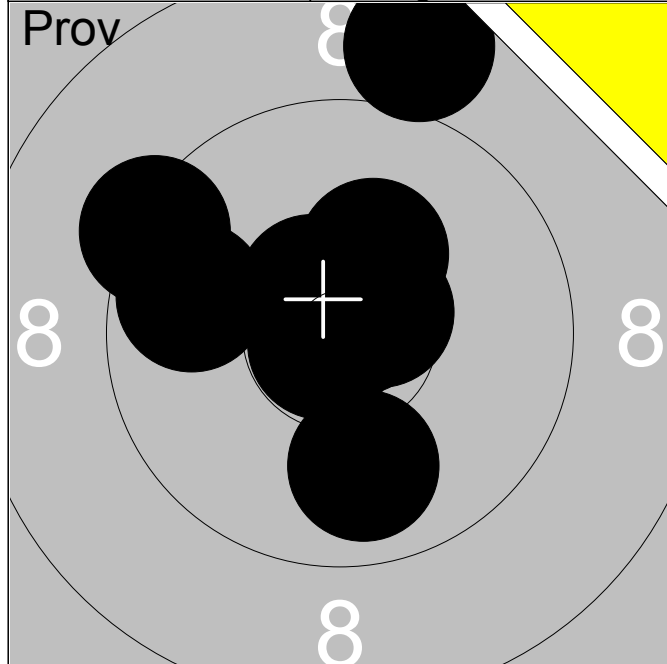

1:	9.8	↖
2:	9.4	↖
3:	*10.8	↗
4:	*10.6	↗
5:	8.8	↑
6:	10.3	↗
7:	*10.7	↑
8:	10.0	↓
9:	*10.8	↖
10:	*10.6	↖
Serie		101.8
Total		0.0

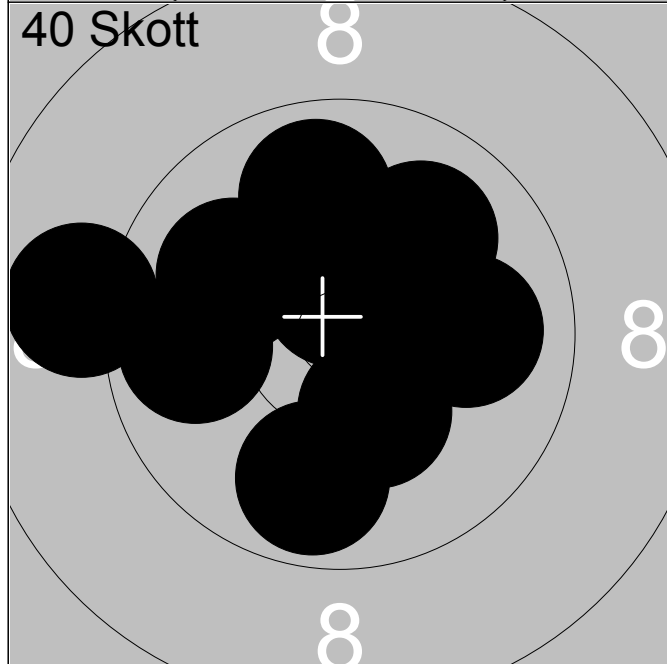

1:	10.1	↖
2:	9.0	↖
3:	10.0	→
4:	9.9	↑
5:	9.9	↖
6:	*10.6	↗
7:	*10.6	↑
8:	10.0	↗
9:	9.9	↓
10:	10.3	↓
Serie		100.3
Total		100.3

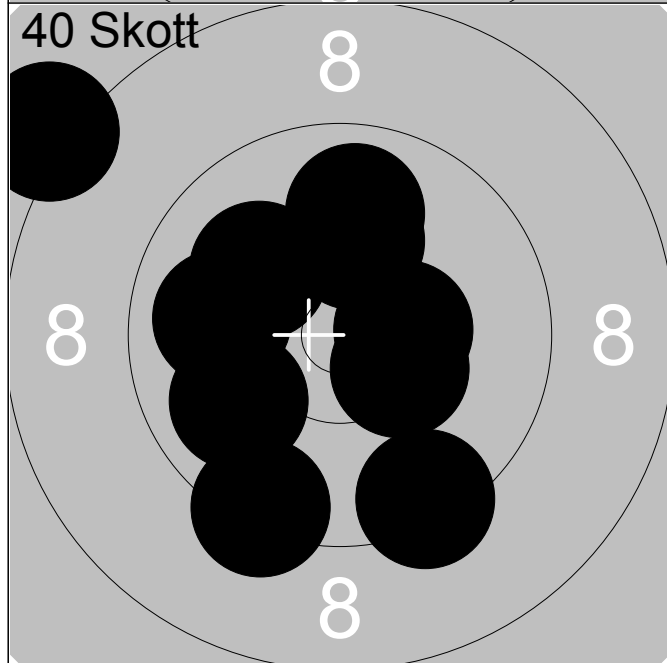

11:	*10.4	→
12:	10.0	↖
13:	10.0	↖
14:	9.4	↓
15:	*10.4	↗
16:	9.4	↖
17:	10.1	↗
18:	10.0	↑
19:	10.2	↑
20:	8.1	↖
Serie		98.0
Total		198.3

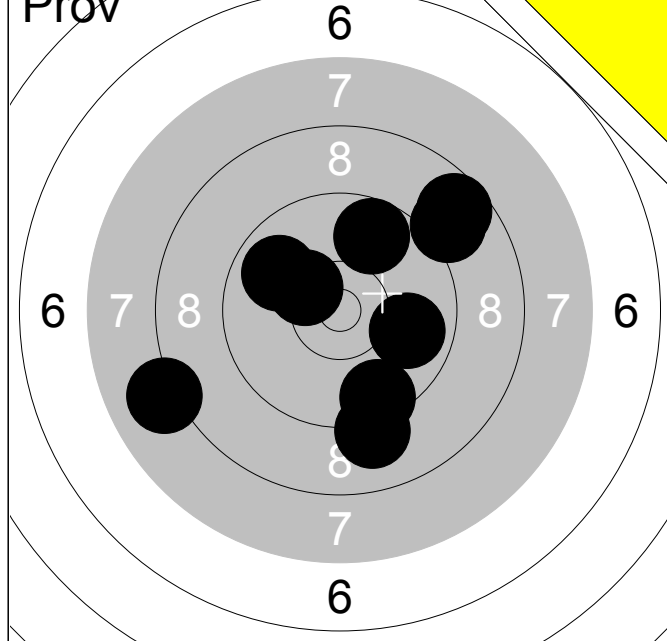

1:	8.9	↗
2:	10.3	↖
3:	8.7	↗
4:	9.9	↖
5:	9.8	↗
6:	8.1	↖
7:	9.6	↓
8:	9.9	→
9:	5.2	↗
10:	9.1	↓
Serie		89.5
Total		0.0

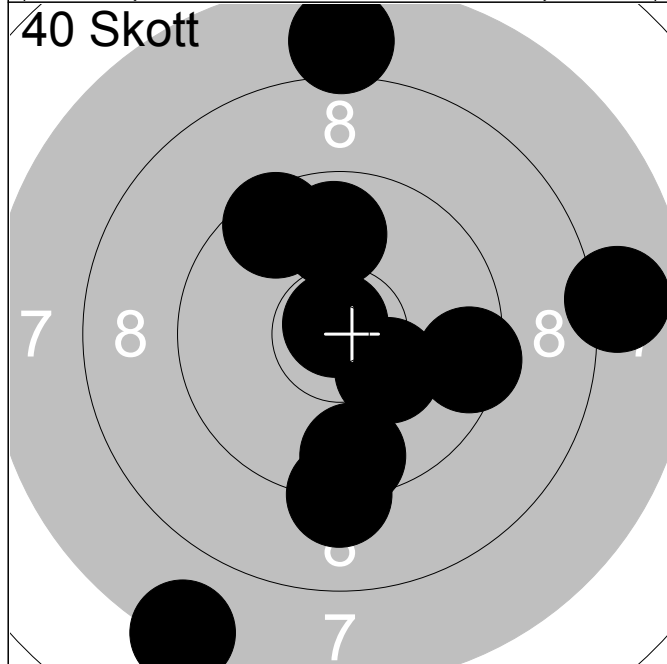

1:	7.4	↓
2:	9.3	↓
3:	9.7	↓
4:	*10.8	↗
5:	9.6	↗
6:	10.3	↘
7:	9.9	↑
8:	8.0	→
9:	7.8	↑
10:	9.6	→
Serie		92.4
Total		92.4

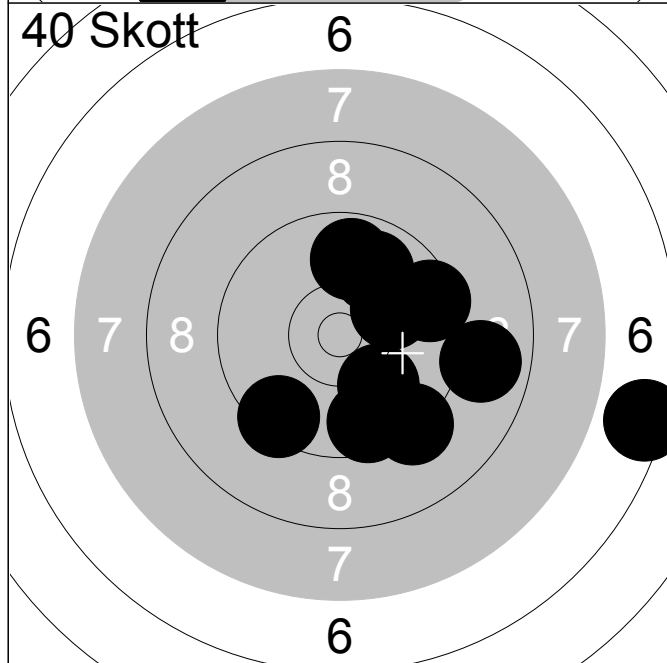

11:	8.9	→
12:	9.9	↗
13:	9.5	↘
14:	10.1	→
15:	10.1	↘
16:	9.9	↑
17:	9.6	→
18:	6.5	→
19:	9.7	↓
20:	9.3	↘
Serie		93.5
Total		185.9

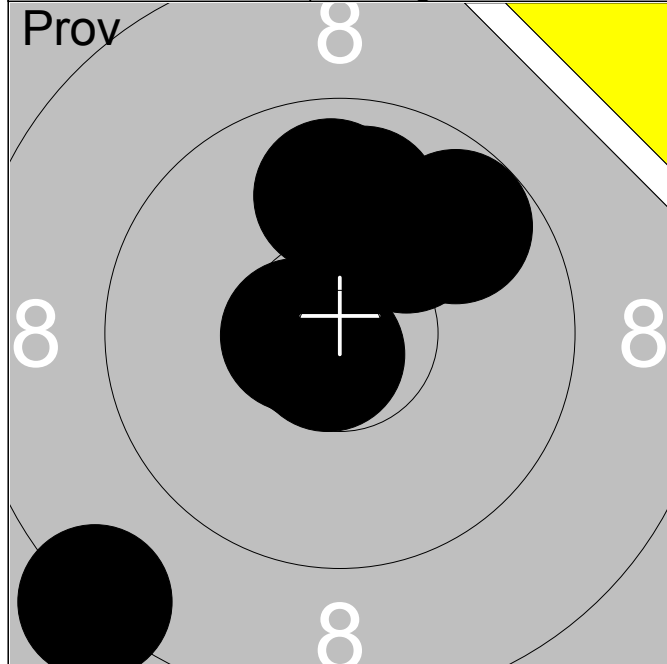

1:	*10.7	←
2:	10.1	↗
3:	9.8	↗
4:	10.0	↑
5:	9.9	↑
6:	*10.6	←
7:	*10.8	↙
8:	8.3	↙

Serie	80.2
Total	0.0

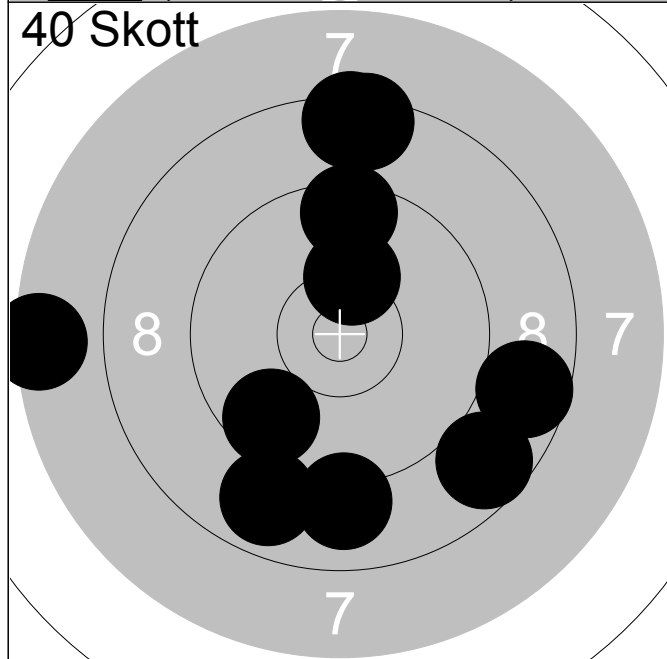

1:	8.5	↑
2:	8.7	→
3:	7.5	←
4:	9.0	↓
5:	9.5	↑
6:	10.3	↑
7:	9.7	↙
8:	8.5	↑
9:	8.7	↘
10:	8.9	↙

Serie	89.3
Total	89.3

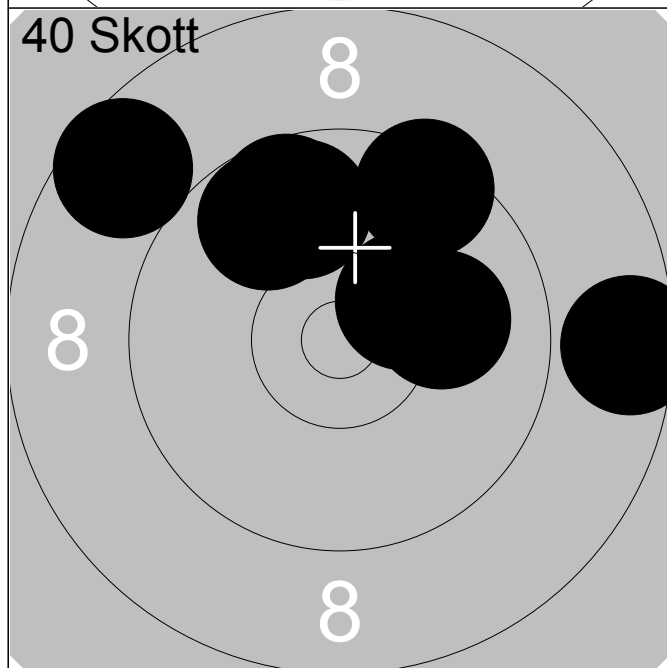

11:	8.6	→
12:	8.7	↖
13:	10.1	→
14:	9.8	↑
15:	9.5	↗
16:	9.8	↖
17:	10.3	↗
18:	9.8	↑

Serie	76.6
Total	165.9

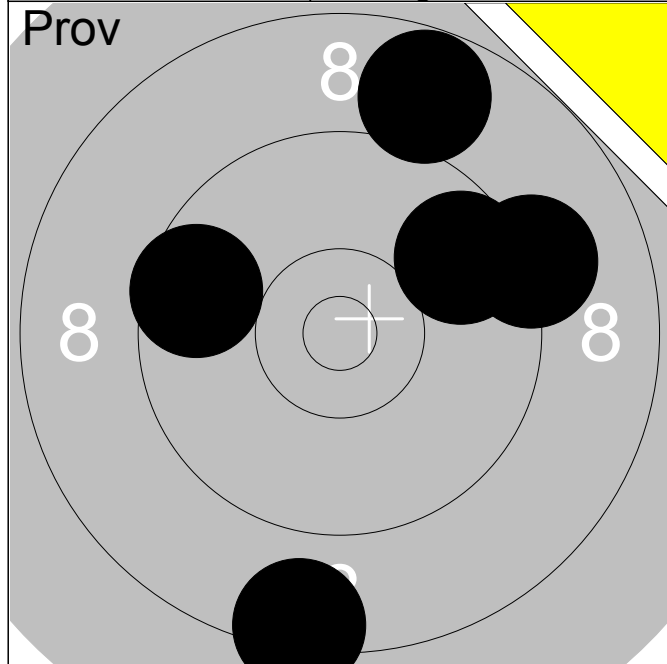

1:	9.7	↗
2:	9.7	↖
3:	8.4	↓
4:	9.2	↗
5:	8.8	↑
Serie		45.8
Total		0.0

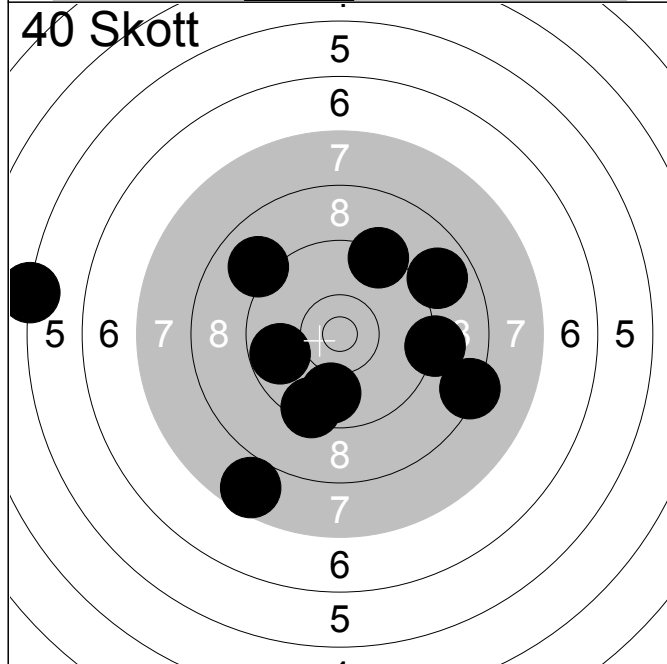

1:	8.4	→
2:	9.8	←
3:	5.2	←
4:	9.9	↓
5:	8.9	↗
6:	7.7	↙
7:	9.4	↗
8:	9.0	↖
9:	9.5	↓
10:	9.2	→
Serie		87.0
Total		87.0

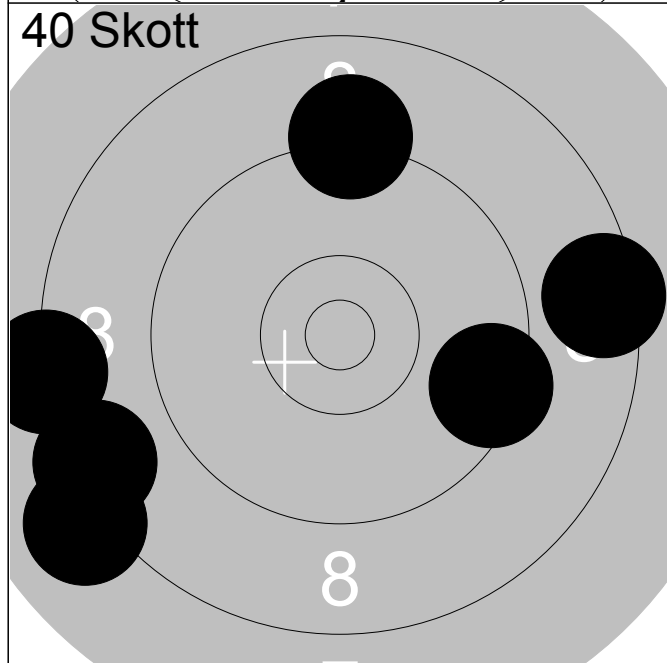

11:	9.1	↑
12:	8.3	←
13:	8.5	→
14:	9.5	↗
15:	8.4	↖
16:	8.1	↙
Serie		51.9
Total		138.9

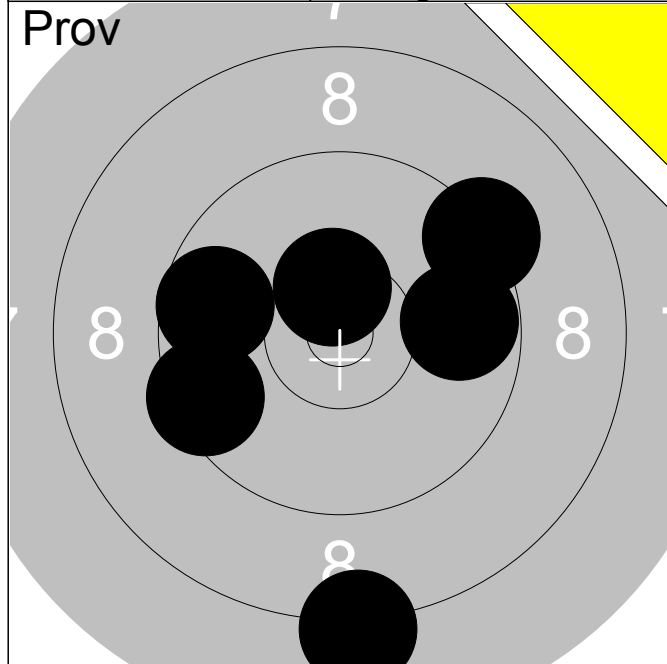

1:	*10.5	↑
2:	9.3	↗
3:	9.5	↖
4:	9.8	→
5:	8.1	↓
6:	9.7	↖

Serie	56.9
Total	0.0

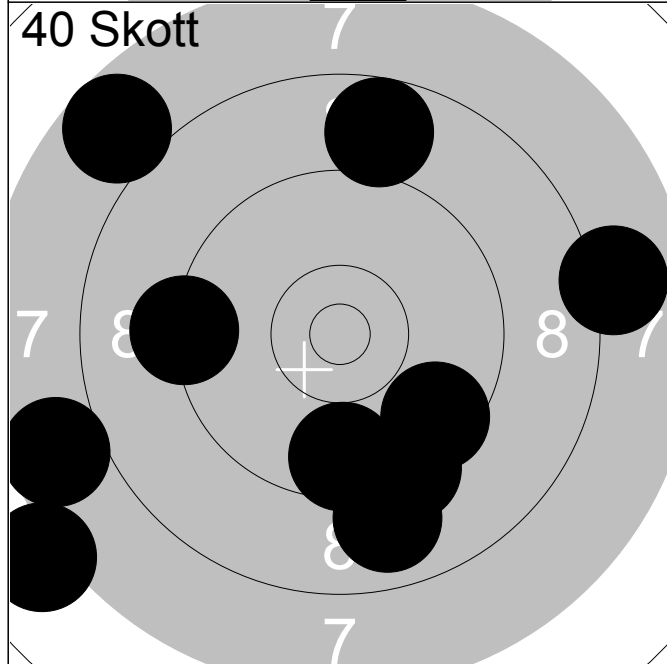

1:	9.7	↓
2:	9.0	↓
3:	8.0	→
4:	7.7	↖
5:	7.1	↖
6:	9.3	↖
7:	7.8	↗
8:	9.6	↘
9:	9.4	↓
10:	8.8	↑

Serie	86.4
Total	86.4

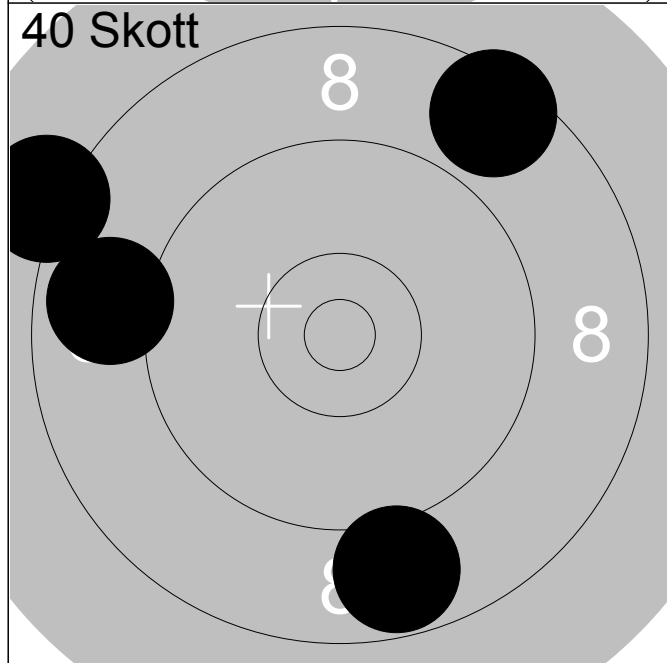

11:	8.1	↖
12:	8.9	↖
13:	8.8	↓
14:	8.6	↗

Serie	34.4
Total	120.8

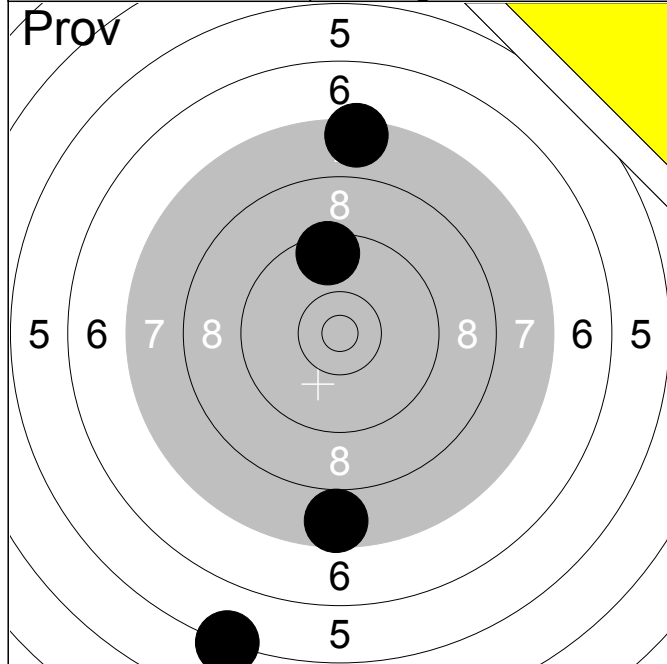

	1:	7.5	↑
	2:	7.7	↓
	3:	5.2	↙
	4:	9.5	↑
Serie		29.9	
Total		0.0	

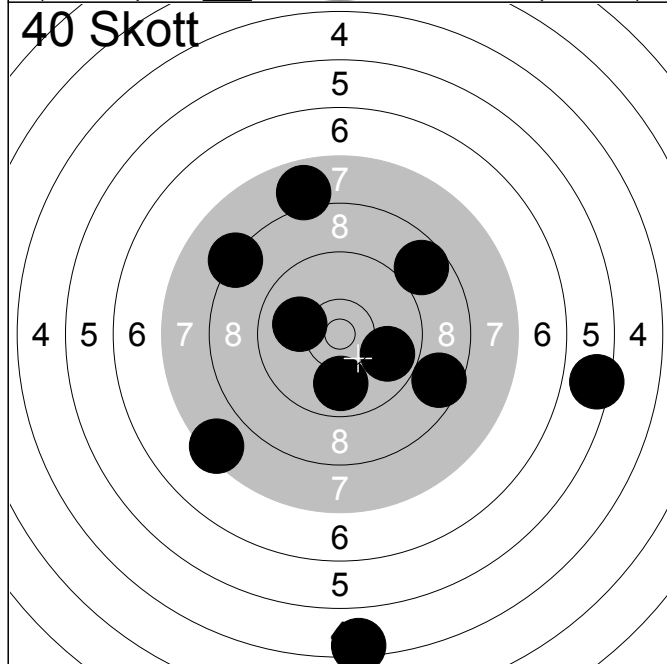

	1:	5.5	→
	2:	9.9	↓
	3:	4.5	↓
	4:	10.1	←
	5:	8.8	↗
	6:	7.5	↙
	7:	8.3	↗
	8:	7.9	↑
	9:	9.9	→
	10:	8.7	→
Serie		81.1	
Total		81.1	

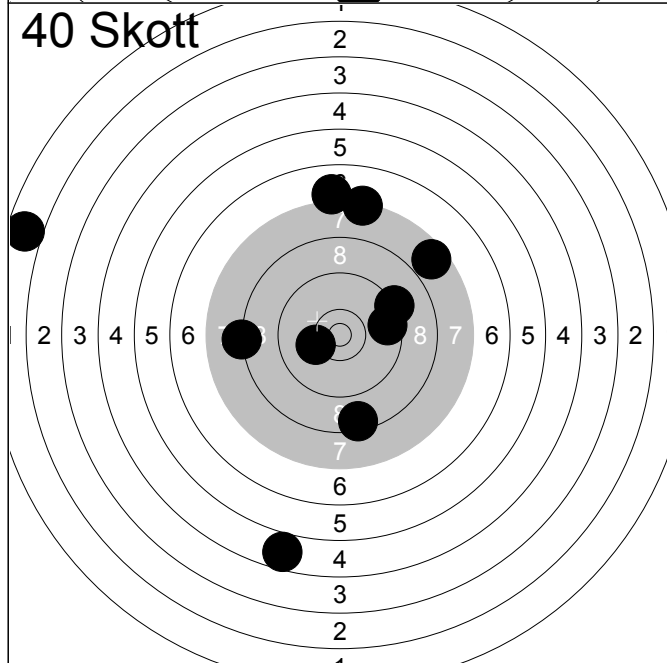

	11:	9.6	→
	12:	1.7	←
	13:	10.2	←
	14:	7.7	↗
	15:	9.2	↗
	16:	8.2	←
	17:	7.3	↑
	18:	8.5	↓
	19:	4.7	↓
	20:	7.0	↑
Serie		74.1	
Total		155.2	

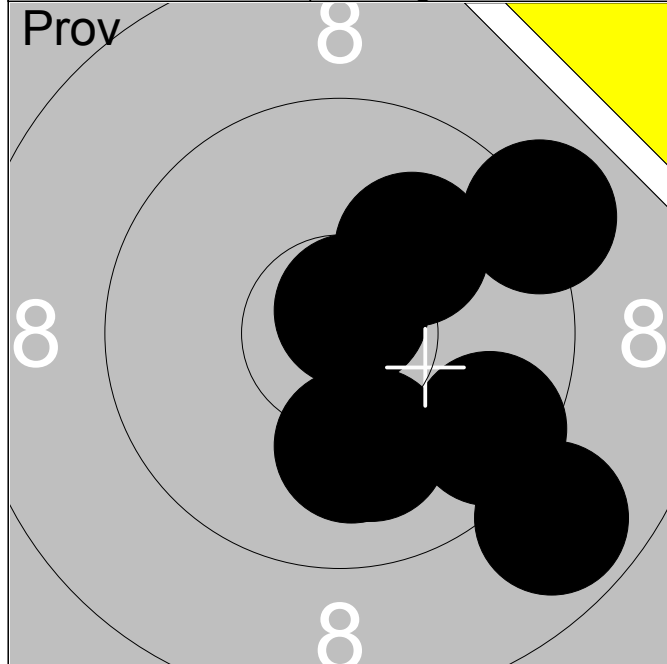

1:	8.9	↘
2:	9.7	↘
3:	10.1	↓
4:	10.1	↗
5:	*10.8	↗
6:	9.3	↗
7:	10.1	↓
Serie		69.0
Total		0.0

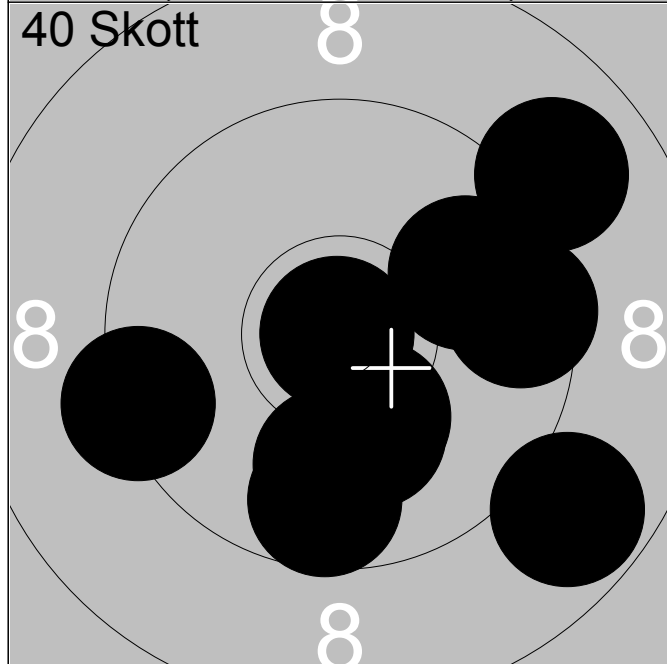

1:	9.0	↗
2:	10.3	↓
3:	9.7	↓
4:	9.6	→
5:	8.9	↘
6:	9.4	←
7:	*10.9	←
8:	10.0	↓
9:	10.2	↓
10:	9.9	↗
Serie		97.9
Total		97.9

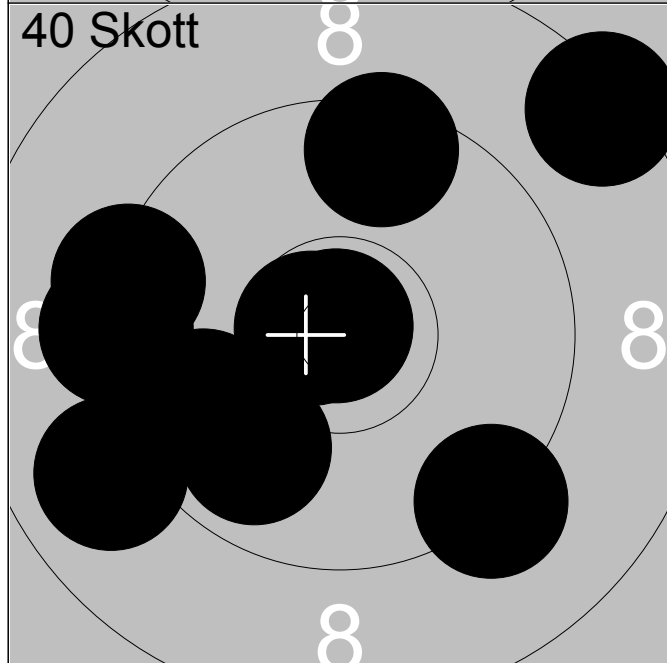

11:	*10.7	←
12:	9.4	←
13:	9.8	←
14:	9.3	↘
15:	9.9	↘
16:	9.6	↑
17:	8.4	↗
18:	9.3	←
19:	9.0	↙
20:	*10.9	↑
Serie		96.3
Total		194.2

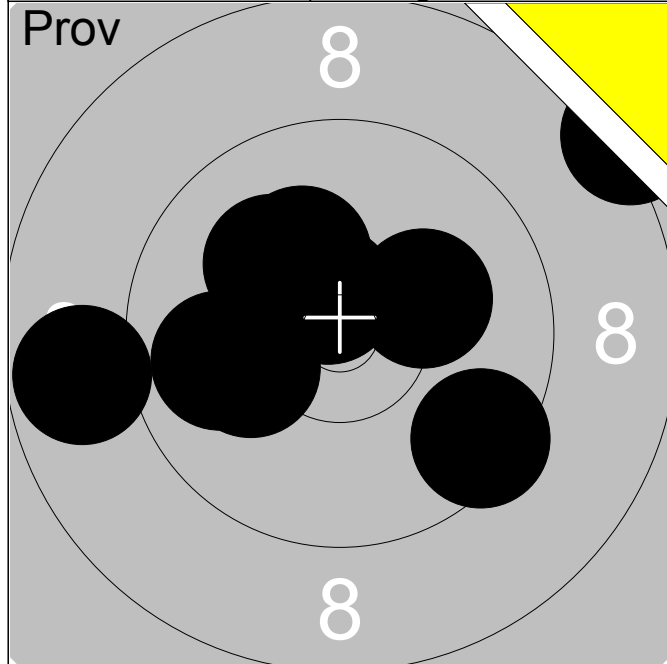

1:	*10.6	↑
2:	10.3	↑
3:	9.5	↓
4:	10.0	←
5:	8.1	↗
6:	*10.5	↗
7:	10.2	↗
8:	8.8	←
9:	10.2	↗
10:	10.2	←
Serie		98.4
Total		0.0

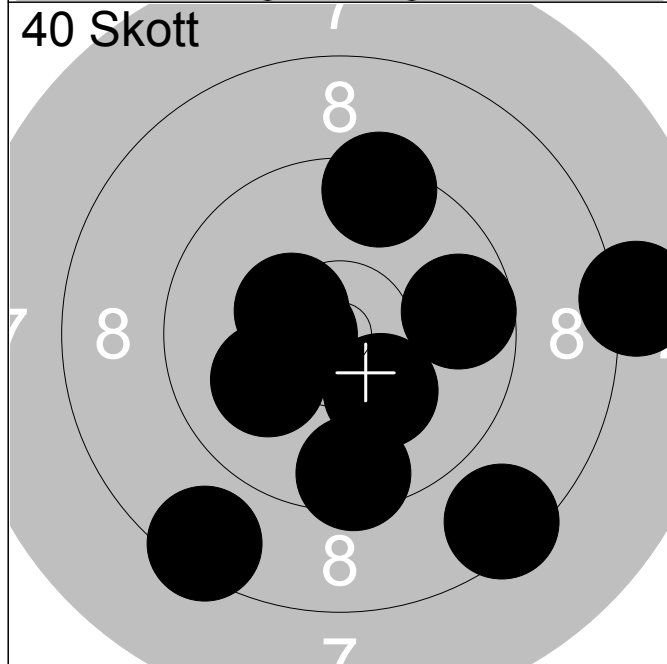

1:	9.8	→
2:	*10.4	↖
3:	10.3	↓
4:	9.6	↓
5:	9.5	↑
6:	8.0	→
7:	*10.6	←
8:	10.1	↖
9:	8.5	↙
10:	8.5	↓
Serie		95.3
Total		95.3

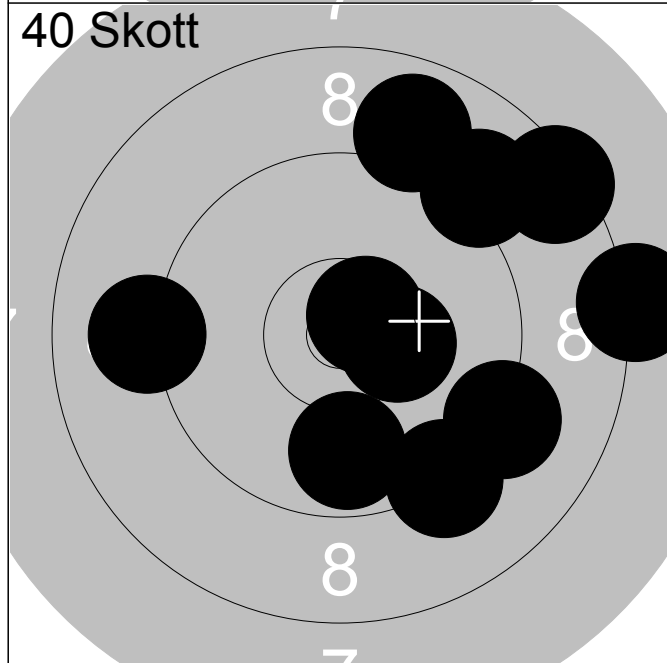

11:	8.5	↗
12:	*10.6	↗
13:	8.9	↑
14:	9.1	←
15:	9.0	↗
16:	9.3	↓
17:	9.2	↘
18:	9.9	↓
19:	*10.4	→
20:	8.1	→
Serie		93.0
Total		188.3