

Relay	Lane	Ida Lundmark	
S	Drängsmark	D	Vb
2014-04-13	Startskottet 2014	Umeå skytteallians	
Sight Prone		Sight Prone	
60 Prone		60 Prone	
60 Prone		60 Prone	
60 Prone		60 Prone	

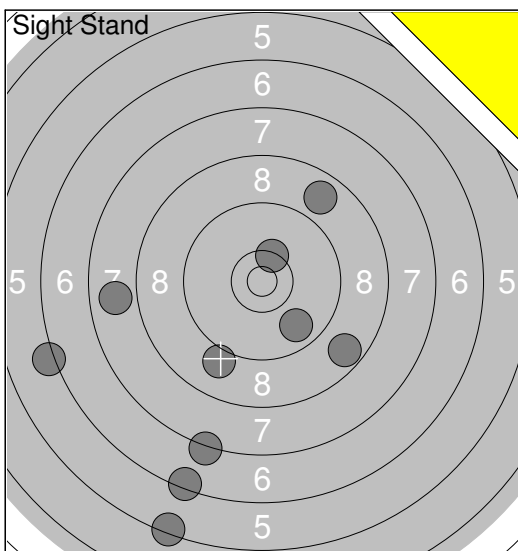

1:	9.8	↘
2:	9.0	↘
3:	7.8	←
4:	8.7	↘
5:	6.2	←
6:	8.8	↗
7:	10.4x	↗
8:	6.4	↘
9:	5.4	↘
10:	7.2	↘
Series	75.0	
Total	559.0	

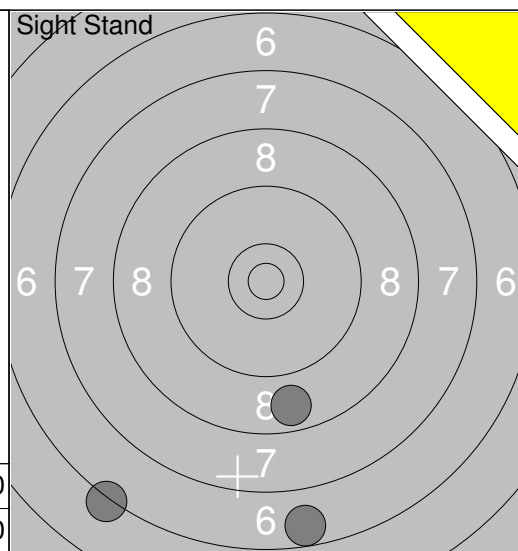

11:	6.7	↘
12:	6.2	↘
13:	8.8	↘
Series	20.0	
Total	559.0	

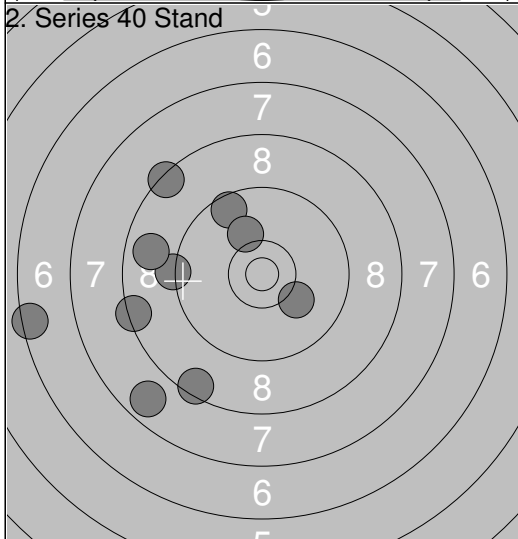

1:	8.5	↘
2:	7.7	↘
3:	6.5	←
4:	9.6	↗
5:	9.3	←
6:	8.4	↗
7:	8.4	←
8:	8.8	←
9:	10.1	↘
10:	10.1	↗
Series	83.0	
Total	642.0	

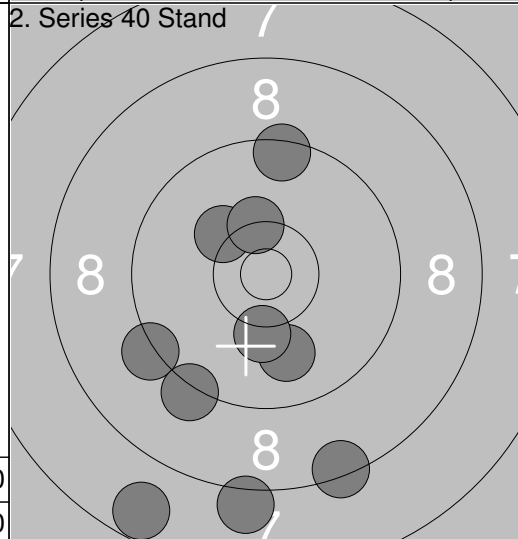

11:	10.0	↘
12:	10.2	↗
13:	8.1	↘
14:	9.2	←
15:	10.2	↘
16:	9.2	↘
17:	8.4	↘
18:	9.4	↗
19:	7.7	↘
20:	10.3x	↗
Series	90.0	
Total	732.0	

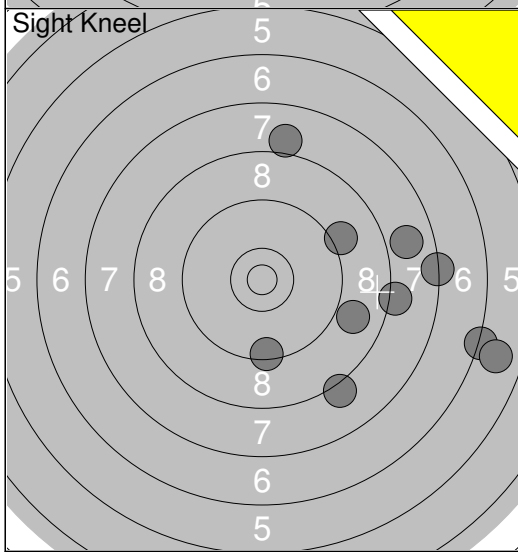

1:	8.0	↗
2:	9.1	↗
3:	7.3	→
4:	7.9	→
5:	6.3	→
6:	9.4	↘
7:	8.2	→
8:	5.9	→
9:	8.1	↘
10:	8.9	↘
Series	75.0	
Total	732.0	

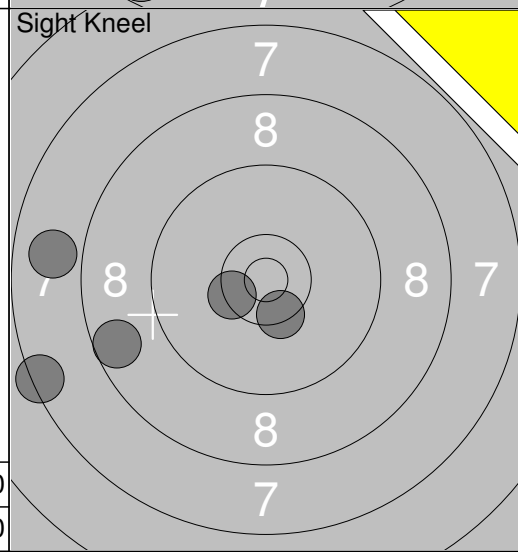

11:	7.9	←
12:	7.4	←
13:	10.4x	↘
14:	8.6	←
15:	10.4x	←
Series	42.0	
Total	732.0	

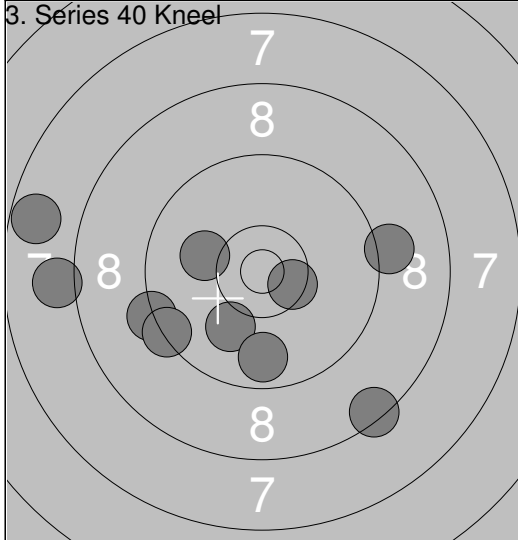

1:	10.1	↘
2:	7.7	←
3:	10.5x	↗
4:	9.3	←
5:	9.4	←
6:	10.1	←
7:	9.1	→
8:	9.7	↘
9:	8.4	↘
10:	8.1	←
Series	89.0	
Total	821.0	

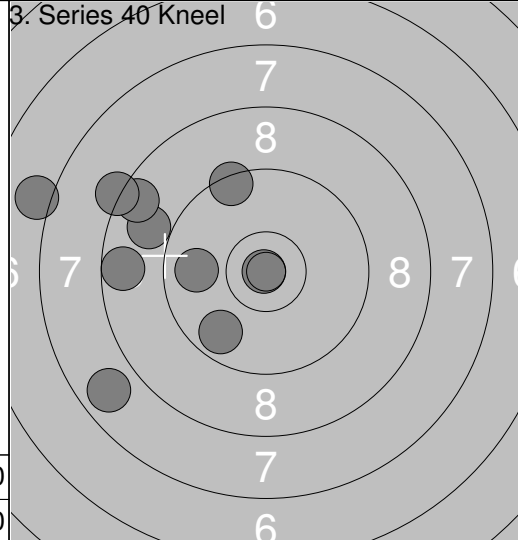

11:	10.9x	←
12:	8.9	←
13:	8.7	←
14:	9.7	↘
15:	7.1	←
16:	7.8	←
17:	8.6	↗
18:	9.8	←
19:	8.2	↗
20:	9.4	↗
Series	83.0	
Total	904.0	

Relay	Lane	Lennart Westermark			
S		Drängsmark		V65	Vb
2014-04-13		Startskottet 2014		Umeå skytteallians	
Sight Prone		1: 7.7 ↙ 2: 4.8 ↓ 3: 4.0 ↓ 4: 4.0 ↓ 5: 9.2 ↓ 6: 8.4 ↓ 7: 9.6 ↓ 8: 9.1 ↙ 9: 9.9 ↓ 10: 9.3 ↓	Sight Prone	11: 9.3 ↓ 12: 8.9 ↙ 13: 10.1 ↙ 14: 9.1 ↗ 15: 9.5 ↗ 16: 9.6 ↗ 17: 10.1 ↗ 18: 9.5 → 19: 9.6 ↗ 20: 9.2 ↓	
		Series 72.0 Total 0.0		Series 91.0 Total 0.0	
60 Prone		1: 9.8 ↓ 2: 8.3 ↑ 3: 9.5 → 4: 8.8 ↑ 5: 8.6 ↓ 6: 6.8 ↙ 7: 8.4 ↙ 8: 9.1 ↙ 9: 8.9 ↓ 10: 9.2 ↗	60 Prone	11: 10.6x → 12: 9.7 ↗ 13: 10.4x ↙ 14: 10.5x ↗ 15: 10.5x ↙ 16: 9.8 ↗ 17: 8.9 ↙ 18: 9.5 → 19: 10.4x ↗ 20: 10.3 ↗	
		Series 82.0 Total 82.0		Series 95.0 Total 177.0	
60 Prone		21: 9.8 ↓ 22: 9.9 ↙ 23: 9.9 ↙ 24: 10.6x ↙ 25: 10.0 → 26: 9.5 → 27: 9.5 ↓ 28: 9.8 ↑ 29: 8.7 ↙ 30: 10.7x ↙	60 Prone	31: 9.0 ↗ 32: 9.2 → 33: 8.9 ↗ 34: 9.0 ↑ 35: 10.4x ↙ 36: 7.6 ↙ 37: 9.4 ↓ 38: 9.7 ↓ 39: 8.6 → 40: 7.6 ↙	
		Series 92.0 Total 269.0		Series 85.0 Total 354.0	
60 Prone		41: 9.5 → 42: 7.6 ↓ 43: 10.1 ↙ 44: 9.3 ↙ 45: 8.4 ↗ 46: 9.6 ↑ 47: 8.4 ↙ 48: 9.5 → 49: 9.4 ↙ 50: 10.5x ↗	60 Prone	51: 9.6 → 52: 7.7 ↗ 53: 9.9 → 54: 7.4 ↙ 55: 9.5 ↙ 56: 8.9 ↓ 57: 9.3 ↙ 58: 9.6 ↙ 59: 9.5 ↓ 60: 0.0	
		Series 88.0 Total 442.0		Series 76.0 Total 518.0	

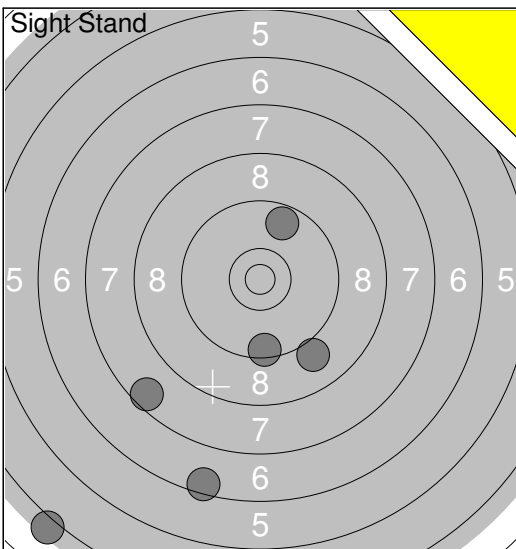

- 1: 6.5 ↓
- 2: 7.6 ↙
- 3: 9.0 ↘
- 4: 4.1 ↙
- 5: 9.5 ↓
- 6: 9.7 ↗

Series	44.0
Total	518.0

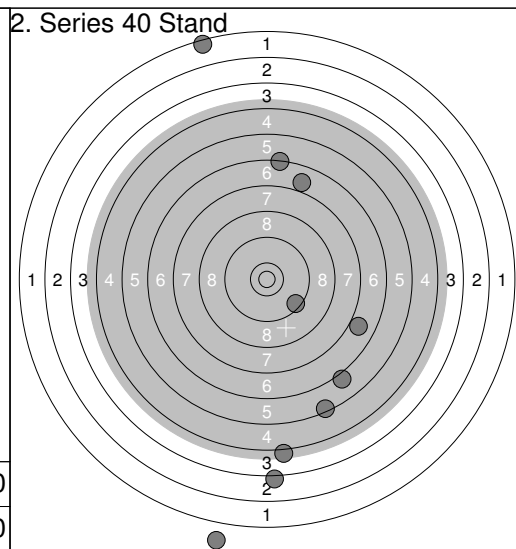

- 1: 5.4 ↓
- 2: 3.2 ↓
- 3: 4.1 ↓
- 4: 6.9 ↗
- 5: 1.4 ↗
- 6: 6.1 ↓
- 7: 7.0 →
- 8: 0.0 ↓
- 9: 9.5 ↓
- 10: 6.3 ↗

Series	47.0
Total	565.0

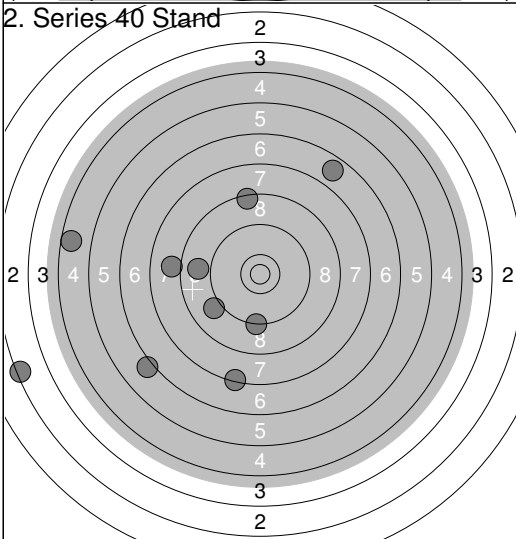

- 11: 9.1 ↙
- 12: 8.9 ←
- 13: 7.4 ↓
- 14: 4.6 ←
- 15: 9.3 ↓
- 16: 6.1 ↙
- 17: 8.4 ↗
- 18: 8.0 ←
- 19: 2.4 ←
- 20: 6.8 ↗

Series	67.0
Total	632.0

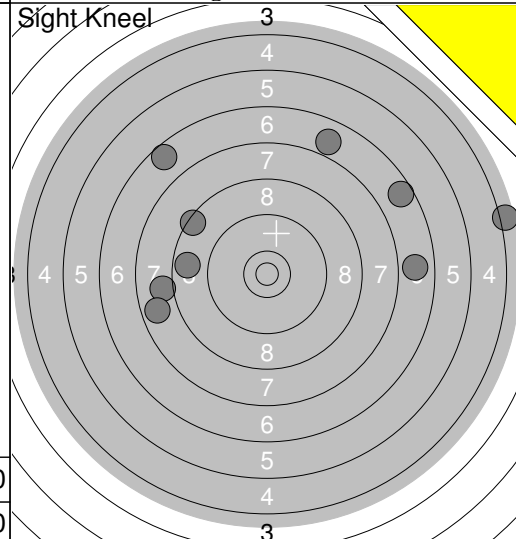

- 1: 6.9 ↗
- 2: 6.6 ↗
- 3: 8.0 ←
- 4: 8.7 ←
- 5: 4.2 →
- 6: 7.7 ←
- 7: 6.8 →
- 8: 8.4 ↗
- 9: 6.6 →

Series	59.0
Total	632.0

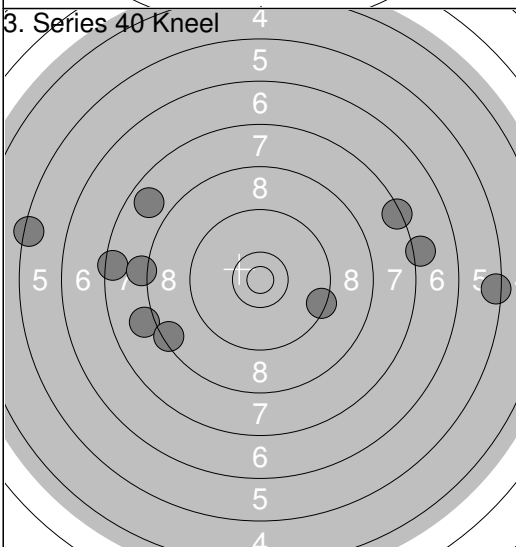

- 1: 7.8 ↙
- 2: 7.4 →
- 3: 7.1 →
- 4: 7.5 ←
- 5: 5.4 ←
- 6: 5.4 →
- 7: 8.1 ←
- 8: 8.4 ←
- 9: 8.2 ←
- 10: 9.4 →

Series	71.0
Total	703.0

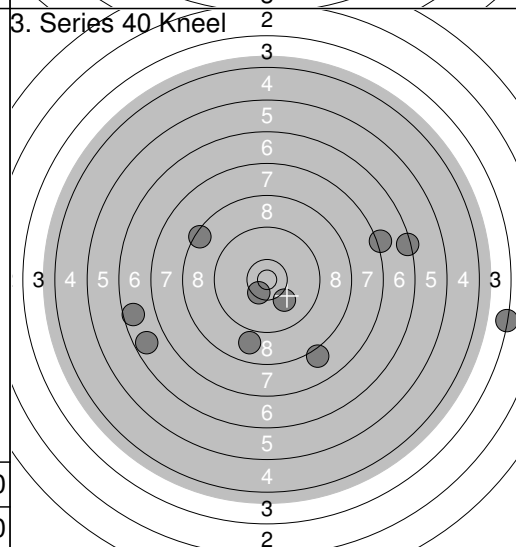

- 11: 7.2 →
- 12: 6.4 →
- 13: 10.1 ↓
- 14: 6.7 ←
- 15: 10.5x ↓
- 16: 8.1 ↓
- 17: 8.9 ↓
- 18: 8.4 ↗
- 19: 6.6 ←
- 20: 3.3 →

Series	72.0
Total	775.0

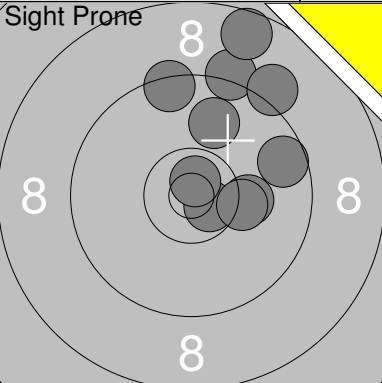
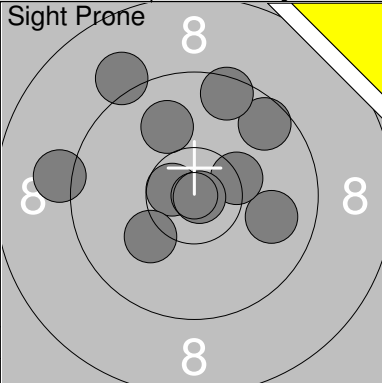
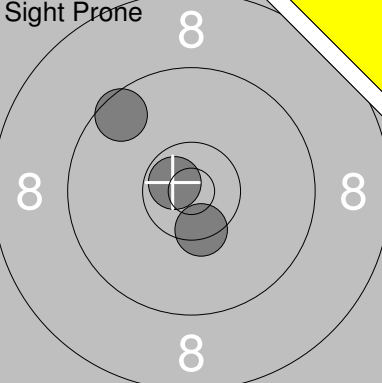
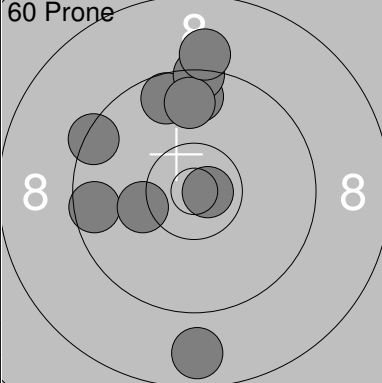
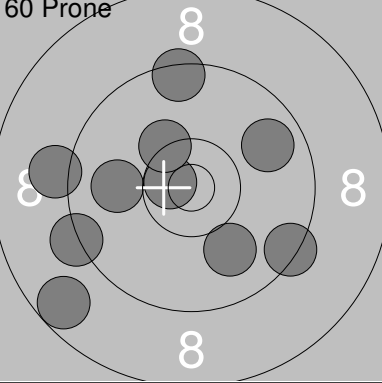
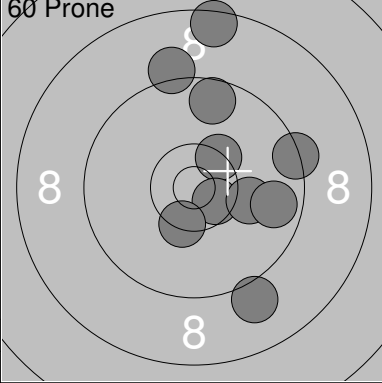
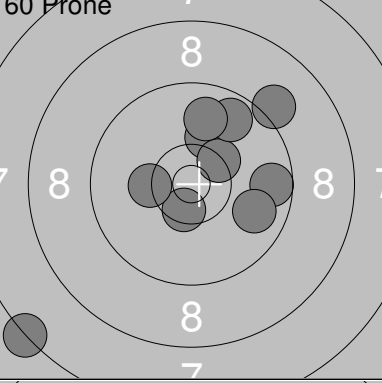
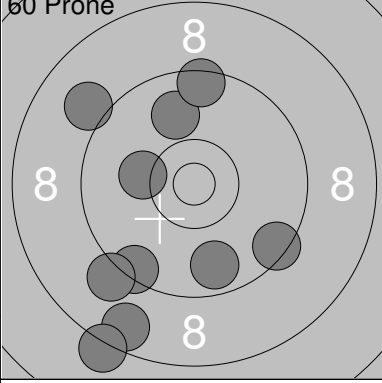
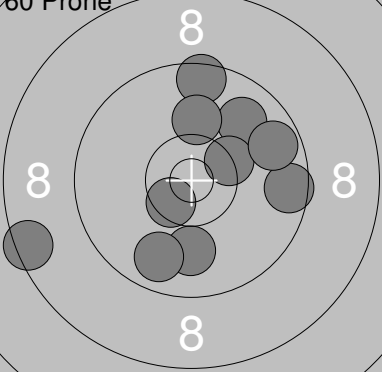
Relay	Lane	Freja Vredin			
S	3	Umeå	DJB Vb		
2014-04-13	Startskottet 2014	Umeå skytteallians			
Sight Prone		1: 10.2 → 2: 9.9 ↑ 3: 9.2 ↑ 4: 8.6 ↑ 5: 9.4 ↑ 6: 9.6 → 7: 9.1 ↗ 8: 10.7x ↘ 9: 10.3 → 10: 10.7x ↑ Series 93.0 Total 0.0	Sight Prone		11: 9.6 ↗ 12: 9.9 → 13: 9.5 ↑ 14: 10.3x → 15: 9.1 ↗ 16: 10.0 ↑ 17: 10.7x ↗ 18: 10.1 ↘ 19: 10.9x → 20: 9.1 ← Series 95.0 Total 0.0
Sight Prone		21: 9.6 ↗ 22: 10.4x ↘ 23: 10.7x ↗ Series 29.0 Total 0.0	60 Prone		1: 9.7 ↑ 2: 10.8x → 3: 9.6 ← 4: 9.6 ↑ 5: 9.4 ↑ 6: 8.8 ↓ 7: 9.7 ↑ 8: 9.1 ↑ 9: 10.2 ← 10: 9.4 ↗ Series 91.0 Total 91.0
60 Prone		11: 10.7x ← 12: 9.4 ↘ 13: 8.7 ↘ 14: 10.0 ↘ 15: 10.0 ← 16: 9.3 ← 17: 9.1 ← 18: 9.4 ↑ 19: 10.3x ↗ 20: 9.8 → Series 93.0 Total 184.0	60 Prone		21: 10.4x ↗ 22: 9.6 ↑ 23: 8.5 ↑ 24: 9.1 ↘ 25: 10.6x ↘ 26: 10.4x ↘ 27: 9.2 ↑ 28: 10.1 → 29: 9.7 → 30: 9.4 → Series 93.0 Total 277.0
60 Prone		31: 9.1 ↗ 32: 10.1 ↑ 33: 10.4x ↗ 34: 9.7 → 35: 9.7 ↑ 36: 9.8 → 37: 10.5x ↘ 38: 10.3 ← 39: 9.9 ↑ 40: 7.3 ↘ Series 92.0 Total 369.0	60 Prone		41: 8.6 ↘ 42: 9.7 ↘ 43: 9.5 ↘ 44: 9.9 ↑ 45: 9.5 ↑ 46: 10.2 ← 47: 9.4 ↘ 48: 9.0 ↗ 49: 8.2 ↘ 50: 9.1 ↘ Series 89.0 Total 458.0
60 Prone		51: 9.6 → 52: 9.9 ↗ 53: 10.0 ↓ 54: 9.8 ↓ 55: 10.5x ↘ 56: 10.3x → 57: 9.5 ↑ 58: 10.1 ↑ 59: 8.5 ← 60: 9.7 → Series 93.0 Total 551.0			



Relay	Lane	William Öster	
S	6	Umeå	HJB Vb
2014-04-13	Startskottet 2014	Umeå skytteallians	
Sight Prone		1: 9.8 ↗ 2: 10.8x ↘ 3: 8.3 ↙ 4: 10.2 ↗ 5: 9.3 ← 6: 9.2 ← 7: 8.9 ← 8: 9.9 ← 9: 9.8 → 10: 9.5 ← Series 90.0 Total 0.0	Sight Prone
			11: 9.9 ← 12: 10.5x ↘ 13: 10.0 ← 14: 8.6 ↑ 15: 9.4 ↓ 16: 10.5x ↓ 17: 7.9 ↑ 18: 9.8 ↘ Series 72.0 Total 0.0
60 Prone		1: 9.8 ↑ 2: 8.5 → 3: 10.5x ← 4: 10.6x ↗ 5: 9.8 → 6: 9.5 ↑ 7: 9.1 ← 8: 9.4 ← 9: 9.7 ↓ 10: 9.5 ↓ Series 91.0 Total 91.0	60 Prone
			11: 9.4 ↗ 12: 10.6x ↗ 13: 9.0 ← 14: 9.8 ↓ 15: 9.6 ← 16: 10.2 → 17: 9.7 → 18: 10.0 ↑ 19: 9.5 ↑ 20: 9.2 ↗ Series 93.0 Total 184.0
60 Prone		21: 9.8 ↑ 22: 9.8 ↗ 23: 10.1 ↘ 24: 10.0 ← 25: 9.9 ↑ 26: 10.6x ↑ 27: 9.0 ↑ 28: 10.7x → 29: 10.5x ← 30: 9.9 ↗ Series 95.0 Total 279.0	60 Prone
			31: 9.8 ← 32: 10.4x ↑ 33: 8.0 ↑ 34: 10.0 ← 35: 9.9 ↓ 36: 8.4 ↗ 37: 10.4x ↗ 38: 9.2 ↓ 39: 10.0 ← 40: 9.5 → Series 92.0 Total 371.0
60 Prone		41: 9.7 ↓ 42: 10.6x ↗ 43: 10.1 ↗ 44: 9.7 → 45: 10.3x ↓ 46: 9.4 ↓ 47: 10.4x ↓ 48: 9.0 ← 49: 9.9 ↗ 50: 10.6x ↗ Series 95.0 Total 466.0	60 Prone
			51: 9.2 ↑ 52: 9.6 ↑ 53: 9.8 ↗ 54: 9.8 ↘ 55: 10.5x ↗ 56: 8.4 ↓ 57: 9.2 ↑ 58: 9.0 → 59: 10.4x ↓ 60: 10.3x ↑ Series 92.0 Total 558.0

<p><b>Sight Prone</b></p>	<p>1: 8.3 ↑ 2: 10.2 ← 3: 9.3 ↗ 4: 8.7 ↗ 5: 8.7 ↗ 6: 9.6 ↓ 7: 10.8x → 8: 10.2 ↗ 9: 10.7x → 10: 9.9 ←</p> <p>Series 91.0 Total 0.0</p>	<p><b>60 Prone</b></p>	<p>1: 9.6 ↓ 2: 10.6x → 3: 10.1 → 4: 10.8x ↑ 5: 10.2 ↓ 6: 10.1 ← 7: 10.0 → 8: 9.5 ↑ 9: 9.9 → 10: 10.2 ↗</p> <p>Series 97.0 Total 97.0</p>
---------------------------	------------------------------------------------------------------------------------------------------------------------------------------------------------------------------	------------------------	----------------------------------------------------------------------------------------------------------------------------------------------------------------------------------

<p><b>60 Prone</b></p>	<p>11: 10.5x ↑ 12: 9.8 ↑ 13: 10.0 ↓ 14: 10.7x ↓ 15: 9.9 → 16: 10.5x ← 17: 10.6x → 18: 9.9 ← 19: 9.4 ↓ 20: 9.5 →</p> <p>Series 95.0 Total 192.0</p>	<p><b>60 Prone</b></p>	<p>21: 10.2 ↓ 22: 9.8 → 23: 10.4x ↗ 24: 10.2 ↑ 25: 9.8 ← 26: 10.2 ↓ 27: 10.0 ↑ 28: 10.5x ↓ 29: 9.6 ↓ 30: 9.0 ↗</p> <p>Series 96.0 Total 288.0</p>
------------------------	--------------------------------------------------------------------------------------------------------------------------------------------------------------------------------------------	------------------------	-------------------------------------------------------------------------------------------------------------------------------------------------------------------------------------------

<p><b>60 Prone</b></p>	<p>31: 9.5 ↓ 32: 9.8 → 33: 9.7 ↓ 34: 9.9 ↗ 35: 10.1 ↓ 36: 10.4x ↓ 37: 9.8 ↓ 38: 9.4 ↓ 39: 9.8 ← 40: 10.3x ↓</p> <p>Series 93.0 Total 381.0</p>	<p><b>60 Prone</b></p>	<p>41: 9.2 ↓ 42: 8.7 ← 43: 9.5 ← 44: 9.5 ← 45: 10.2 ↓ 46: 10.2 ← 47: 9.8 ↓ 48: 10.5x ← 49: 10.4x ↓ 50: 10.2 ↓</p> <p>Series 94.0 Total 475.0</p>
------------------------	----------------------------------------------------------------------------------------------------------------------------------------------------------------------------------------	------------------------	------------------------------------------------------------------------------------------------------------------------------------------------------------------------------------------

<p><b>60 Prone</b></p>	<p>51: 9.1 ↓ 52: 8.5 ↓ 53: 9.5 ↗ 54: 10.2 → 55: 10.4x ↗ 56: 9.9 ↗ 57: 8.1 → 58: 9.7 ↗ 59: 9.3 ↓ 60: 10.1 ↗</p> <p>Series 91.0 Total 566.0</p>		
------------------------	---------------------------------------------------------------------------------------------------------------------------------------------------------------------------------------	--	--

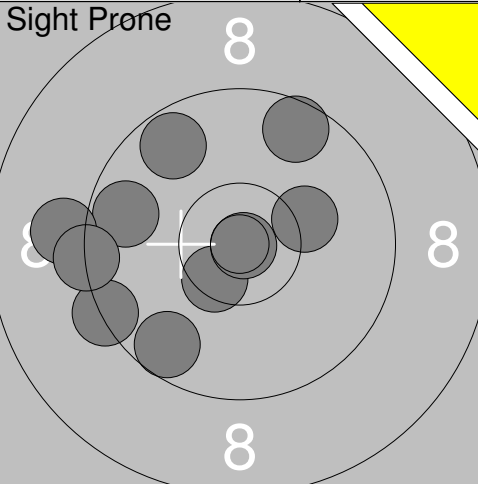
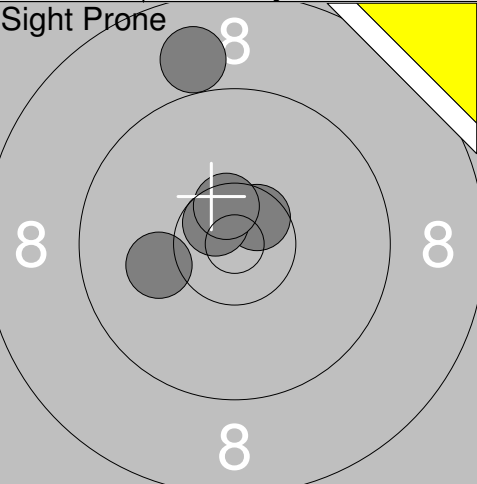
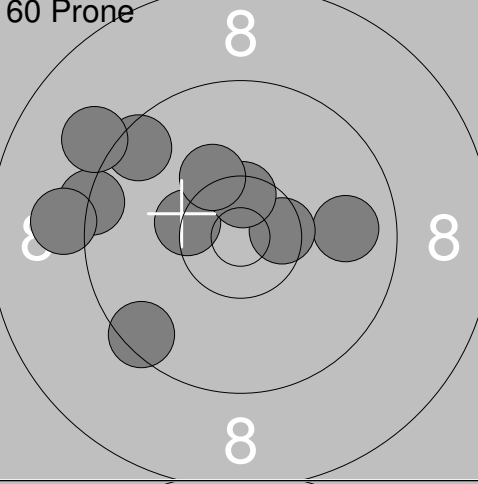
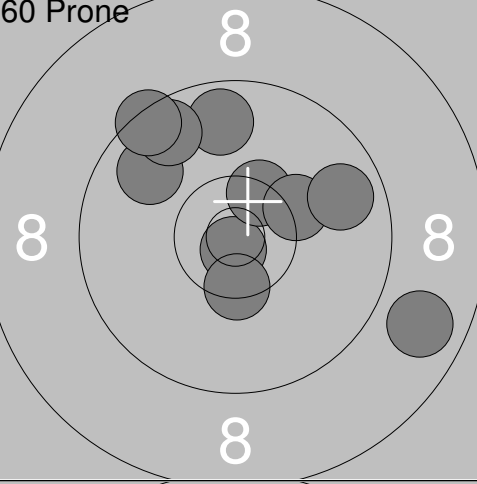
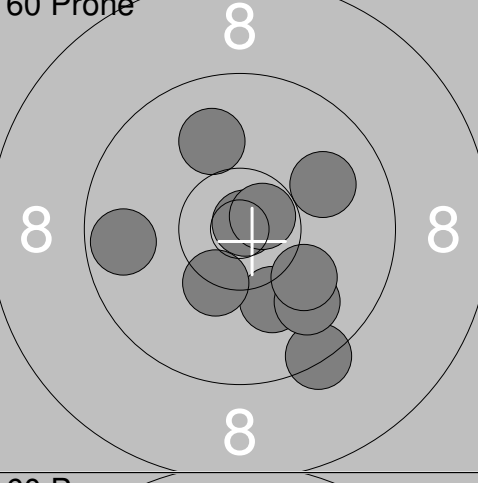
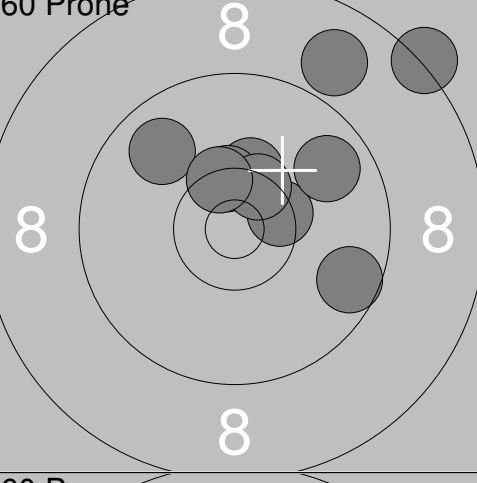
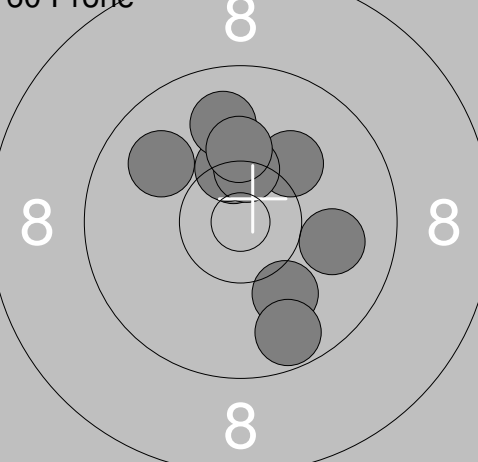
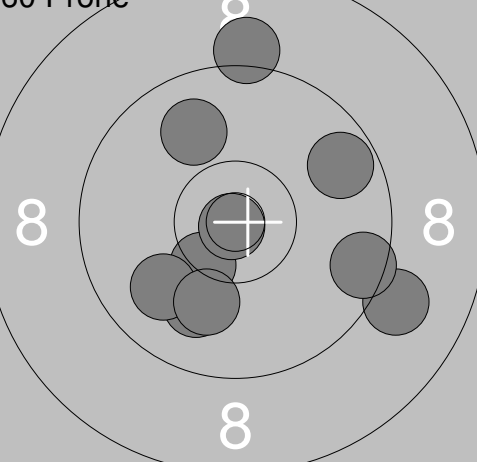
Relay	Lane	Håkan Lidman	
1	9		
S	Skellefteå	V65	Vb
2014-04-13	Startskottet 2014	Umeå skytteallians	
Sight Prone		1: 9.3 ← 2: 10.5x ↓ 3: 10.2 → 4: 10.9x → 5: 9.7 ← 6: 9.1 ← 7: 9.3 ← 8: 9.7 ↗ 9: 9.6 ↓ 10: 9.6 ↗ Series 93.0 Total 0.0	Sight Prone  11: 10.1 ← 12: 10.6x ↗ 13: 10.6x ↖ 14: 10.5x ↑ 15: 9.0 ↑ Series 49.0 Total 0.0
60 Prone		1: 9.8 → 2: 10.5x → 3: 9.5 ↗ 4: 10.4x ← 5: 9.5 ↓ 6: 9.3 ← 7: 10.5x ↑ 8: 9.1 ↗ 9: 9.1 ← 10: 10.3 ↗ Series 94.0 Total 94.0	60 Prone  11: 9.8 ↖ 12: 9.7 ↑ 13: 9.6 ↖ 14: 10.8x ↓ 15: 10.4x ↗ 16: 8.8 → 17: 10.4x ↓ 18: 10.2 ↗ 19: 9.4 ↗ 20: 9.8 → Series 93.0 Total 187.0
60 Prone		21: 9.4 ↓ 22: 10.1 ↓ 23: 10.9x ↗ 24: 9.7 ← 25: 10.3x ↓ 26: 9.9 ↓ 27: 10.7x ↗ 28: 10.0 → 29: 10.1 ↓ 30: 10.0 ↑ Series 97.0 Total 284.0	60 Prone  31: 8.3 ↗ 32: 10.4x → 33: 10.3x ↑ 34: 9.6 → 35: 9.8 ↗ 36: 10.4x ↑ 37: 9.8 ↖ 38: 8.9 ↗ 39: 10.4x ↗ 40: 10.4x ↑ Series 93.0 Total 377.0
60 Prone		41: 10.1 ↗ 42: 10.4x ↑ 43: 10.0 → 44: 9.9 ↗ 45: 10.1 ↓ 46: 9.7 ↓ 47: 10.4x ↑ 48: 9.9 ↑ 49: 10.4x ↑ 50: 10.2 ↑ Series 97.0 Total 474.0	60 Prone  51: 10.0 ↓ 52: 10.4x ↓ 53: 9.9 ↓ 54: 9.7 → 55: 9.1 → 56: 10.0 ↓ 57: 10.9x ↓ 58: 9.9 ↖ 59: 9.1 ↑ 60: 9.5 → Series 94.0 Total 568.0

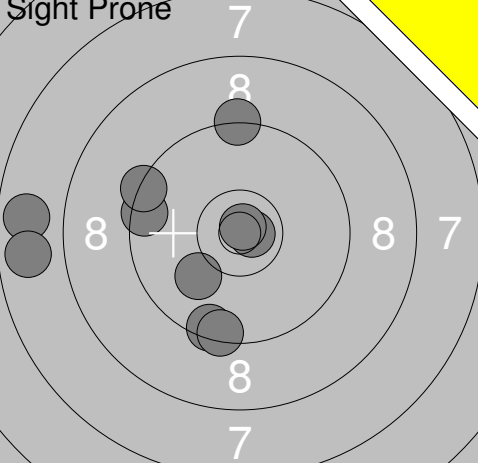
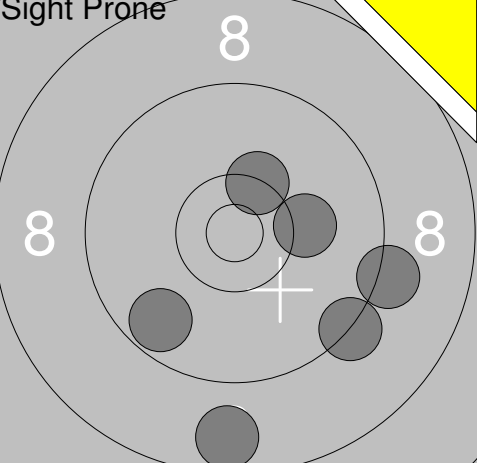

 <p style="text-align:center;">Sight Prone</p>	 <p style="text-align:center;">Sight Prone</p>	
<p>1: 7.8 ←</p> <p>2: 9.5 ←</p> <p>3: 7.8 ←</p> <p>4: 9.4 ↖</p> <p>5: 10.8x →</p> <p>6: 10.0 ↙</p> <p>7: 9.5 ↓</p> <p>8: 9.4 ↓</p> <p>9: 10.9x ↗</p> <p>10: 9.3 ↑</p>	<p>11: 10.3x ↗</p> <p>12: 9.2 →</p> <p>13: 10.2 →</p> <p>14: 9.3 ↘</p> <p>15: 9.7 ↘</p> <p>16: 8.7 ↓</p>	
Series 89.0	Series 55.0	
Total 0.0	Total 0.0	

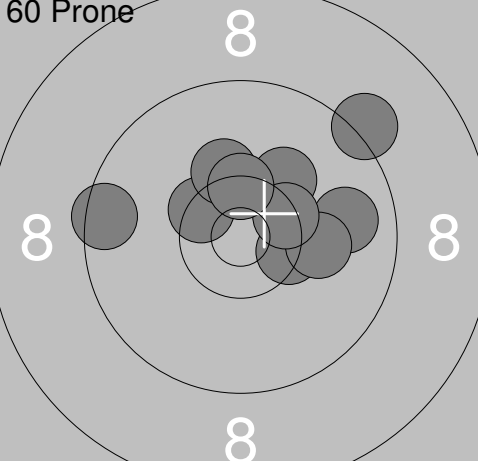
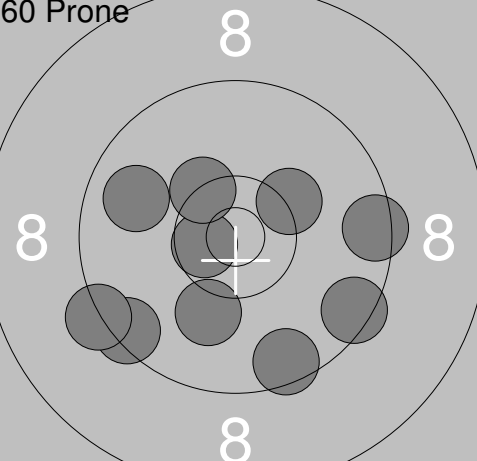
 <p style="text-align:center;">60 Prone</p>	 <p style="text-align:center;">60 Prone</p>	
<p>1: 9.2 ↗</p> <p>2: 10.2 ↗</p> <p>3: 10.4x →</p> <p>4: 9.8 →</p> <p>5: 10.1 →</p> <p>6: 10.4x ↗</p> <p>7: 10.2 ↑</p> <p>8: 9.5 ←</p> <p>9: 10.4x →</p> <p>10: 10.4x ↑</p>	<p>11: 9.5 ↓</p> <p>12: 9.8 ←</p> <p>13: 10.3 →</p> <p>14: 9.5 ↘</p> <p>15: 10.6x ←</p> <p>16: 9.4 ↙</p> <p>17: 10.3x ↗</p> <p>18: 9.5 →</p> <p>19: 9.3 ←</p> <p>20: 10.1 ↓</p>	
Series 97.0	Series 94.0	
Total 97.0	Total 191.0	

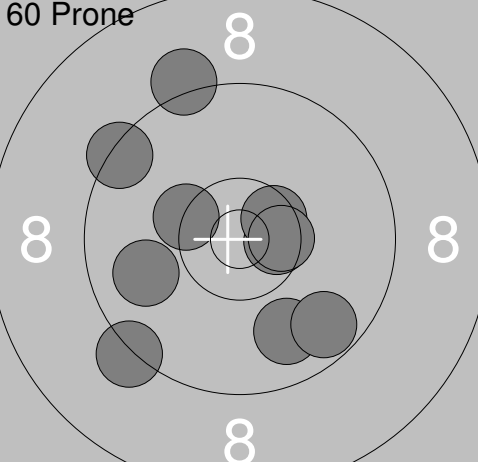
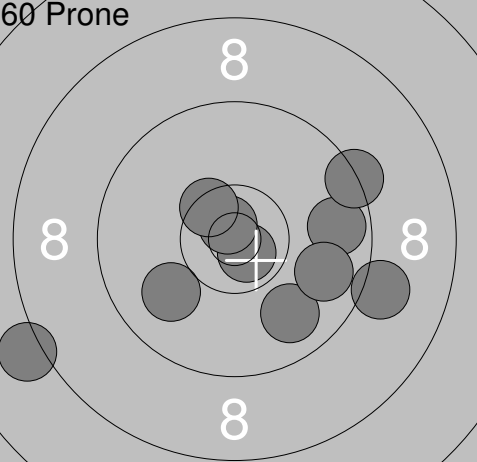
 <p style="text-align:center;">60 Prone</p>	 <p style="text-align:center;">60 Prone</p>	
<p>21: 9.9 ←</p> <p>22: 9.4 ↗</p> <p>23: 10.3x ←</p> <p>24: 9.9 ↓</p> <p>25: 9.3 ↙</p> <p>26: 9.7 ↘</p> <p>27: 10.6x →</p> <p>28: 9.2 ↑</p> <p>29: 10.5x ↗</p> <p>30: 10.5x →</p>	<p>31: 9.7 →</p> <p>32: 9.1 →</p> <p>33: 10.7x ↘</p> <p>34: 10.8x ↗</p> <p>35: 8.1 ←</p> <p>36: 9.3 →</p> <p>37: 9.8 ↘</p> <p>38: 10.0 ←</p> <p>39: 10.5x ↗</p> <p>40: 9.8 →</p>	
Series 94.0	Series 93.0	
Total 285.0	Total 378.0	

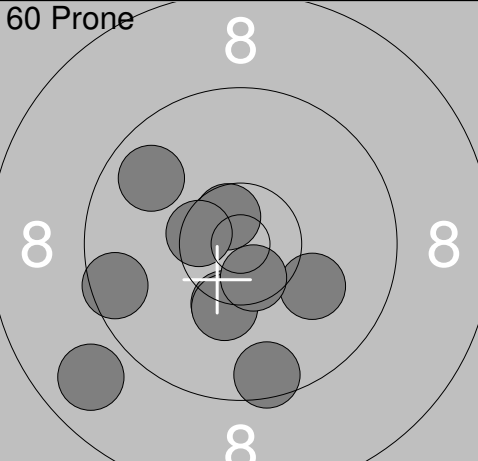
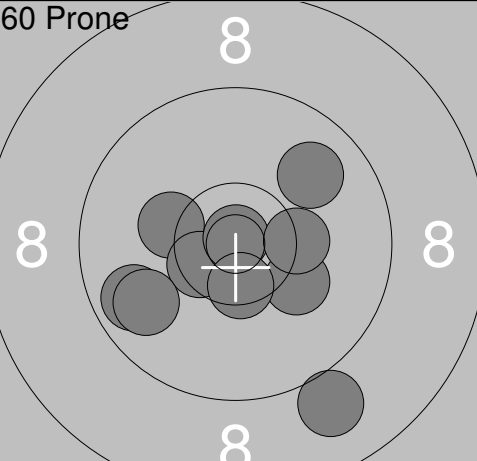
 <p style="text-align:center;">60 Prone</p>	 <p style="text-align:center;">60 Prone</p>	
<p>41: 9.5 ↓</p> <p>42: 8.8 ↙</p> <p>43: 9.6 ←</p> <p>44: 10.6x ↗</p> <p>45: 9.8 ↗</p> <p>46: 10.1 ↘</p> <p>47: 10.3x ↘</p> <p>48: 10.5x ←</p> <p>49: 10.3 ↓</p> <p>50: 10.6x ↘</p>	<p>51: 9.7 ←</p> <p>52: 10.2 ←</p> <p>53: 10.5x ←</p> <p>54: 10.2 →</p> <p>55: 9.8 ↙</p> <p>56: 9.0 ↓</p> <p>57: 10.9x ↑</p> <p>58: 9.9 ↗</p> <p>59: 10.3x →</p> <p>60: 10.5x ↘</p>	
Series 95.0	Series 96.0	
Total 473.0	Total 569.0	

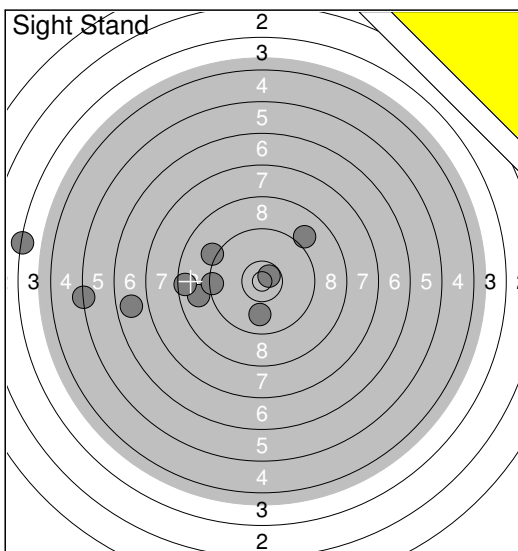

1:	3.3	←
2:	9.0	↗
3:	6.8	←
4:	9.2	↖
5:	5.3	←
6:	10.7x	↗
7:	9.9	↓
8:	8.9	←
9:	8.5	←
10:	9.4	←
Series	76.0	
Total	569.0	

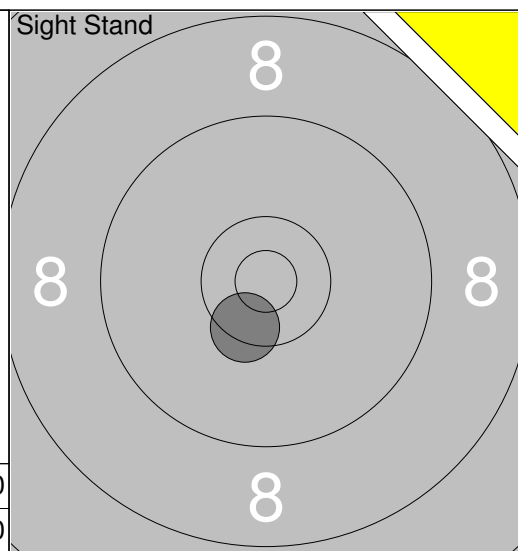

11:	10.4x	↙
Series	10.0	
Total	569.0	

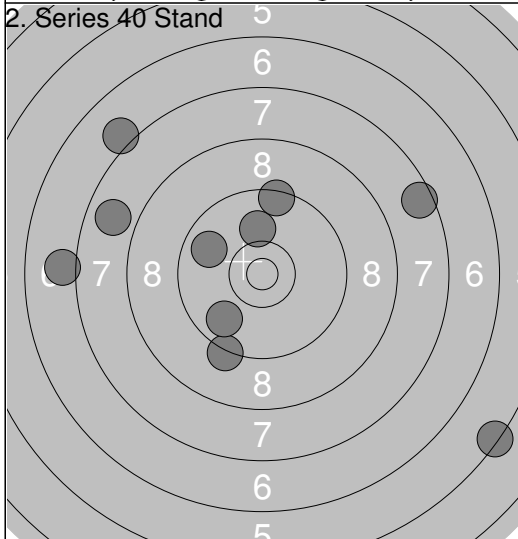

1:	9.2	↘
2:	10.1	↑
3:	7.8	←
4:	9.8	↖
5:	7.1	↗
6:	5.4	↘
7:	7.0	←
8:	7.6	→
9:	9.4	↑
10:	9.8	↙
Series	79.0	
Total	648.0	

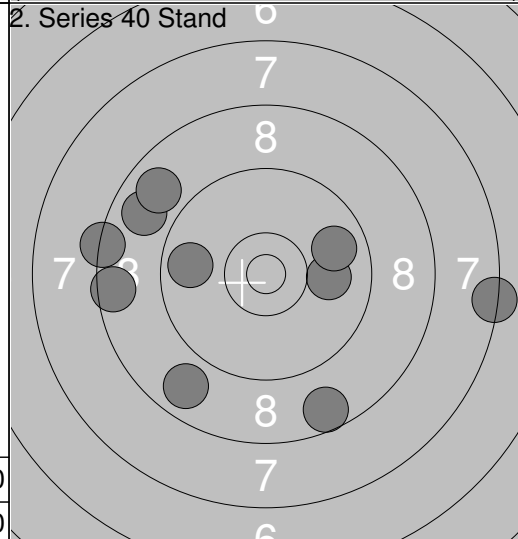

11:	9.8	←
12:	8.8	↙
13:	8.8	↖
14:	10.0	→
15:	7.4	→
16:	8.6	↘
17:	8.4	←
18:	9.8	→
19:	8.6	←
20:	8.8	↖
Series	83.0	
Total	731.0	

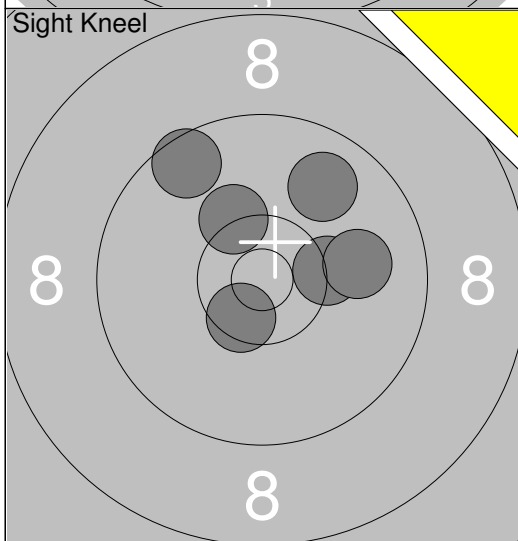

1:	10.5x	↙
2:	9.6	↖
3:	10.3x	→
4:	10.0	→
5:	9.8	↗
6:	10.3	↖
Series	58.0	
Total	731.0	

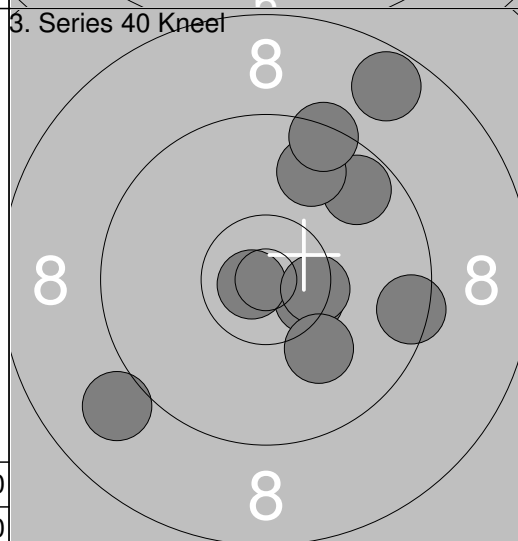

1:	8.7	↗
2:	9.7	↗
3:	9.5	→
4:	9.8	↑
5:	9.0	↙
6:	9.4	↑
7:	10.5x	→
8:	10.8x	←
9:	10.5x	→
10:	10.1	↘
Series	93.0	
Total	824.0	

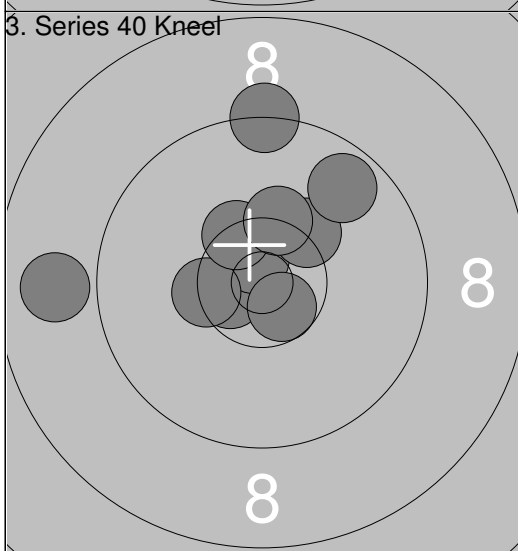

11:	10.6x	←
12:	10.7x	↑
13:	9.3	↑
14:	10.3	↗
15:	10.4x	←
16:	8.9	←
17:	10.6x	↘
18:	9.7	↗
19:	10.4x	↖
20:	10.3x	↑
Series	96.0	
Total	920.0	

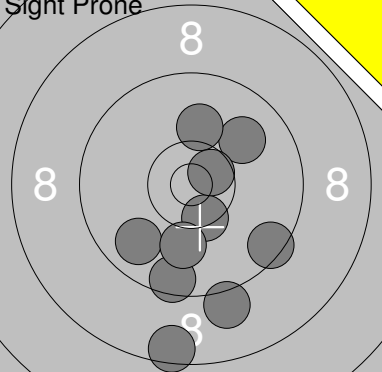
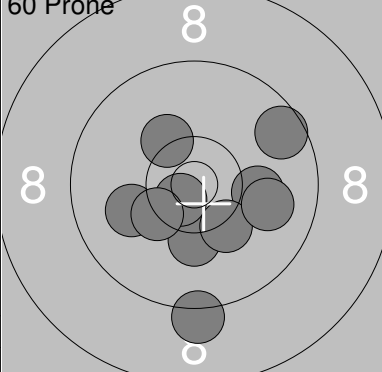
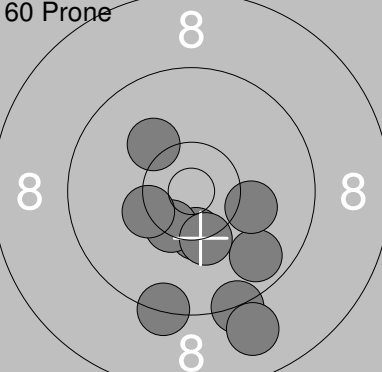
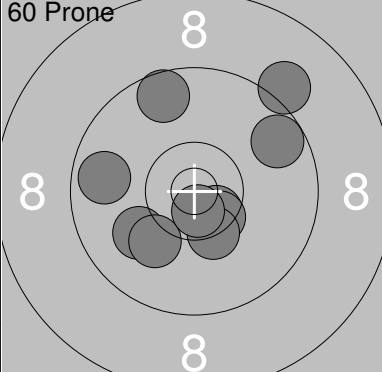
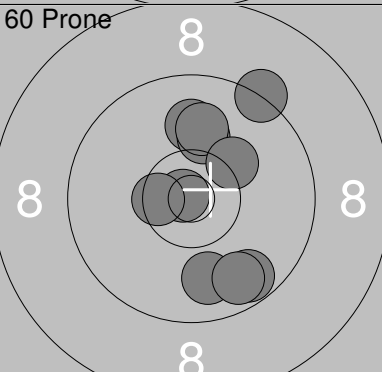
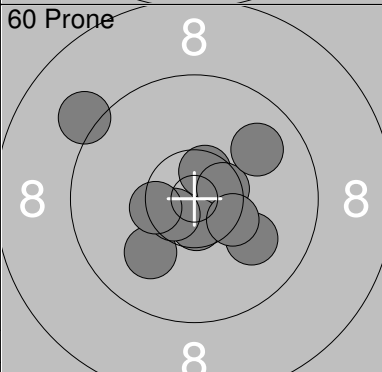
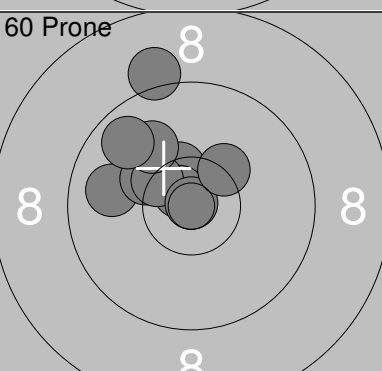
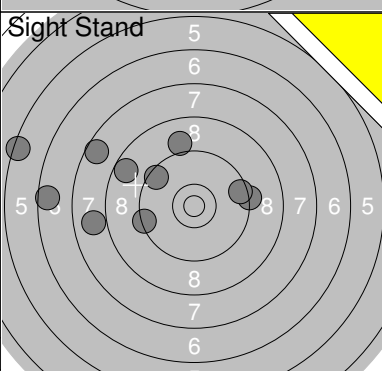
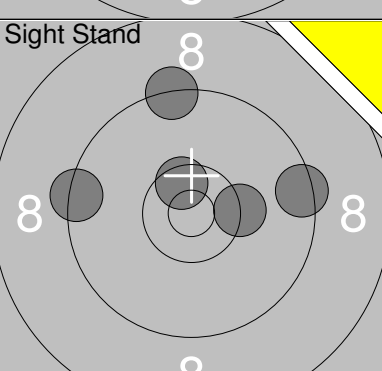
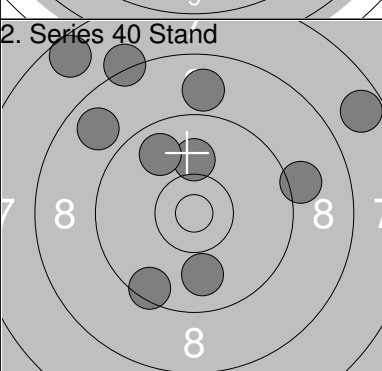
Sight Prone 	<table border="1" style="width:100%; border-collapse: collapse;"> <tr><td>1:</td><td>10.4x</td><td>↘</td></tr> <tr><td>2:</td><td>8.5</td><td>↘</td></tr> <tr><td>3:</td><td>9.1</td><td>↘</td></tr> <tr><td>4:</td><td>9.5</td><td>↘</td></tr> <tr><td>5:</td><td>10.0</td><td>↗</td></tr> <tr><td>6:</td><td>9.5</td><td>↘</td></tr> <tr><td>7:</td><td>10.1</td><td>↗</td></tr> <tr><td>8:</td><td>9.8</td><td>↖</td></tr> <tr><td>9:</td><td>10.6x</td><td>↗</td></tr> <tr><td>10:</td><td>10.1</td><td>↘</td></tr> <tr><td colspan="2"><b>Series</b></td><td><b>94.0</b></td></tr> <tr><td colspan="2"><b>Total</b></td><td><b>0.0</b></td></tr> </table>	1:	10.4x	↘	2:	8.5	↘	3:	9.1	↘	4:	9.5	↘	5:	10.0	↗	6:	9.5	↘	7:	10.1	↗	8:	9.8	↖	9:	10.6x	↗	10:	10.1	↘	<b>Series</b>		<b>94.0</b>	<b>Total</b>		<b>0.0</b>	60 Prone 	<table border="1" style="width:100%; border-collapse: collapse;"> <tr><td>1:</td><td>10.1</td><td>→</td></tr> <tr><td>2:</td><td>9.6</td><td>↗</td></tr> <tr><td>3:</td><td>10.0</td><td>↖</td></tr> <tr><td>4:</td><td>10.2</td><td>↘</td></tr> <tr><td>5:</td><td>10.7x</td><td>↖</td></tr> <tr><td>6:</td><td>10.3</td><td>↗</td></tr> <tr><td>7:</td><td>10.3</td><td>↘</td></tr> <tr><td>8:</td><td>9.9</td><td>→</td></tr> <tr><td>9:</td><td>9.2</td><td>↘</td></tr> <tr><td>10:</td><td>10.3x</td><td>↖</td></tr> <tr><td colspan="2"><b>Series</b></td><td><b>97.0</b></td></tr> <tr><td colspan="2"><b>Total</b></td><td><b>97.0</b></td></tr> </table>	1:	10.1	→	2:	9.6	↗	3:	10.0	↖	4:	10.2	↘	5:	10.7x	↖	6:	10.3	↗	7:	10.3	↘	8:	9.9	→	9:	9.2	↘	10:	10.3x	↖	<b>Series</b>		<b>97.0</b>	<b>Total</b>		<b>97.0</b>
1:	10.4x	↘																																																																									
2:	8.5	↘																																																																									
3:	9.1	↘																																																																									
4:	9.5	↘																																																																									
5:	10.0	↗																																																																									
6:	9.5	↘																																																																									
7:	10.1	↗																																																																									
8:	9.8	↖																																																																									
9:	10.6x	↗																																																																									
10:	10.1	↘																																																																									
<b>Series</b>		<b>94.0</b>																																																																									
<b>Total</b>		<b>0.0</b>																																																																									
1:	10.1	→																																																																									
2:	9.6	↗																																																																									
3:	10.0	↖																																																																									
4:	10.2	↘																																																																									
5:	10.7x	↖																																																																									
6:	10.3	↗																																																																									
7:	10.3	↘																																																																									
8:	9.9	→																																																																									
9:	9.2	↘																																																																									
10:	10.3x	↖																																																																									
<b>Series</b>		<b>97.0</b>																																																																									
<b>Total</b>		<b>97.0</b>																																																																									
60 Prone 	<table border="1" style="width:100%; border-collapse: collapse;"> <tr><td>11:</td><td>10.1</td><td>↗</td></tr> <tr><td>12:</td><td>9.3</td><td>↘</td></tr> <tr><td>13:</td><td>10.4x</td><td>↘</td></tr> <tr><td>14:</td><td>10.4x</td><td>↘</td></tr> <tr><td>15:</td><td>8.9</td><td>↘</td></tr> <tr><td>16:</td><td>9.7</td><td>↘</td></tr> <tr><td>17:</td><td>9.3</td><td>↘</td></tr> <tr><td>18:</td><td>10.1</td><td>→</td></tr> <tr><td>19:</td><td>10.3x</td><td>↖</td></tr> <tr><td>20:</td><td>10.3</td><td>↘</td></tr> <tr><td colspan="2"><b>Series</b></td><td><b>95.0</b></td></tr> <tr><td colspan="2"><b>Total</b></td><td><b>192.0</b></td></tr> </table>	11:	10.1	↗	12:	9.3	↘	13:	10.4x	↘	14:	10.4x	↘	15:	8.9	↘	16:	9.7	↘	17:	9.3	↘	18:	10.1	→	19:	10.3x	↖	20:	10.3	↘	<b>Series</b>		<b>95.0</b>	<b>Total</b>		<b>192.0</b>	60 Prone 	<table border="1" style="width:100%; border-collapse: collapse;"> <tr><td>21:</td><td>9.6</td><td>↗</td></tr> <tr><td>22:</td><td>10.0</td><td>↖</td></tr> <tr><td>23:</td><td>10.5x</td><td>↘</td></tr> <tr><td>24:</td><td>10.1</td><td>↖</td></tr> <tr><td>25:</td><td>10.5x</td><td>↘</td></tr> <tr><td>26:</td><td>9.1</td><td>↗</td></tr> <tr><td>27:</td><td>10.3x</td><td>↘</td></tr> <tr><td>28:</td><td>9.7</td><td>↖</td></tr> <tr><td>29:</td><td>10.7x</td><td>↘</td></tr> <tr><td>30:</td><td>9.7</td><td>↗</td></tr> <tr><td colspan="2"><b>Series</b></td><td><b>96.0</b></td></tr> <tr><td colspan="2"><b>Total</b></td><td><b>288.0</b></td></tr> </table>	21:	9.6	↗	22:	10.0	↖	23:	10.5x	↘	24:	10.1	↖	25:	10.5x	↘	26:	9.1	↗	27:	10.3x	↘	28:	9.7	↖	29:	10.7x	↘	30:	9.7	↗	<b>Series</b>		<b>96.0</b>	<b>Total</b>		<b>288.0</b>
11:	10.1	↗																																																																									
12:	9.3	↘																																																																									
13:	10.4x	↘																																																																									
14:	10.4x	↘																																																																									
15:	8.9	↘																																																																									
16:	9.7	↘																																																																									
17:	9.3	↘																																																																									
18:	10.1	→																																																																									
19:	10.3x	↖																																																																									
20:	10.3	↘																																																																									
<b>Series</b>		<b>95.0</b>																																																																									
<b>Total</b>		<b>192.0</b>																																																																									
21:	9.6	↗																																																																									
22:	10.0	↖																																																																									
23:	10.5x	↘																																																																									
24:	10.1	↖																																																																									
25:	10.5x	↘																																																																									
26:	9.1	↗																																																																									
27:	10.3x	↘																																																																									
28:	9.7	↖																																																																									
29:	10.7x	↘																																																																									
30:	9.7	↗																																																																									
<b>Series</b>		<b>96.0</b>																																																																									
<b>Total</b>		<b>288.0</b>																																																																									
60 Prone 	<table border="1" style="width:100%; border-collapse: collapse;"> <tr><td>31:</td><td>9.3</td><td>↗</td></tr> <tr><td>32:</td><td>10.0</td><td>↗</td></tr> <tr><td>33:</td><td>9.9</td><td>↘</td></tr> <tr><td>34:</td><td>10.1</td><td>↗</td></tr> <tr><td>35:</td><td>9.7</td><td>↘</td></tr> <tr><td>36:</td><td>10.0</td><td>↗</td></tr> <tr><td>37:</td><td>10.2</td><td>↗</td></tr> <tr><td>38:</td><td>9.7</td><td>↘</td></tr> <tr><td>39:</td><td>10.8x</td><td>↗</td></tr> <tr><td>40:</td><td>10.5x</td><td>↖</td></tr> <tr><td colspan="2"><b>Series</b></td><td><b>96.0</b></td></tr> <tr><td colspan="2"><b>Total</b></td><td><b>384.0</b></td></tr> </table>	31:	9.3	↗	32:	10.0	↗	33:	9.9	↘	34:	10.1	↗	35:	9.7	↘	36:	10.0	↗	37:	10.2	↗	38:	9.7	↘	39:	10.8x	↗	40:	10.5x	↖	<b>Series</b>		<b>96.0</b>	<b>Total</b>		<b>384.0</b>	60 Prone 	<table border="1" style="width:100%; border-collapse: collapse;"> <tr><td>41:</td><td>10.6x</td><td>↗</td></tr> <tr><td>42:</td><td>10.5x</td><td>→</td></tr> <tr><td>43:</td><td>9.9</td><td>↗</td></tr> <tr><td>44:</td><td>10.6x</td><td>↘</td></tr> <tr><td>45:</td><td>10.0</td><td>↘</td></tr> <tr><td>46:</td><td>10.0</td><td>↘</td></tr> <tr><td>47:</td><td>10.4x</td><td>↘</td></tr> <tr><td>48:</td><td>10.6x</td><td>↖</td></tr> <tr><td>49:</td><td>10.4x</td><td>↖</td></tr> <tr><td>50:</td><td>9.1</td><td>↗</td></tr> <tr><td colspan="2"><b>Series</b></td><td><b>98.0</b></td></tr> <tr><td colspan="2"><b>Total</b></td><td><b>482.0</b></td></tr> </table>	41:	10.6x	↗	42:	10.5x	→	43:	9.9	↗	44:	10.6x	↘	45:	10.0	↘	46:	10.0	↘	47:	10.4x	↘	48:	10.6x	↖	49:	10.4x	↖	50:	9.1	↗	<b>Series</b>		<b>98.0</b>	<b>Total</b>		<b>482.0</b>
31:	9.3	↗																																																																									
32:	10.0	↗																																																																									
33:	9.9	↘																																																																									
34:	10.1	↗																																																																									
35:	9.7	↘																																																																									
36:	10.0	↗																																																																									
37:	10.2	↗																																																																									
38:	9.7	↘																																																																									
39:	10.8x	↗																																																																									
40:	10.5x	↖																																																																									
<b>Series</b>		<b>96.0</b>																																																																									
<b>Total</b>		<b>384.0</b>																																																																									
41:	10.6x	↗																																																																									
42:	10.5x	→																																																																									
43:	9.9	↗																																																																									
44:	10.6x	↘																																																																									
45:	10.0	↘																																																																									
46:	10.0	↘																																																																									
47:	10.4x	↘																																																																									
48:	10.6x	↖																																																																									
49:	10.4x	↖																																																																									
50:	9.1	↗																																																																									
<b>Series</b>		<b>98.0</b>																																																																									
<b>Total</b>		<b>482.0</b>																																																																									
60 Prone 	<table border="1" style="width:100%; border-collapse: collapse;"> <tr><td>51:</td><td>9.9</td><td>↖</td></tr> <tr><td>52:</td><td>10.4x</td><td>↗</td></tr> <tr><td>53:</td><td>10.2</td><td>↗</td></tr> <tr><td>54:</td><td>10.7x</td><td>↗</td></tr> <tr><td>55:</td><td>10.4x</td><td>↗</td></tr> <tr><td>56:</td><td>10.0</td><td>↗</td></tr> <tr><td>57:</td><td>9.1</td><td>↗</td></tr> <tr><td>58:</td><td>10.9x</td><td>↗</td></tr> <tr><td>59:</td><td>10.3x</td><td>↗</td></tr> <tr><td>60:</td><td>9.8</td><td>↗</td></tr> <tr><td colspan="2"><b>Series</b></td><td><b>97.0</b></td></tr> <tr><td colspan="2"><b>Total</b></td><td><b>579.0</b></td></tr> </table>	51:	9.9	↖	52:	10.4x	↗	53:	10.2	↗	54:	10.7x	↗	55:	10.4x	↗	56:	10.0	↗	57:	9.1	↗	58:	10.9x	↗	59:	10.3x	↗	60:	9.8	↗	<b>Series</b>		<b>97.0</b>	<b>Total</b>		<b>579.0</b>	Sight Stand 	<table border="1" style="width:100%; border-collapse: collapse;"> <tr><td>1:</td><td>8.7</td><td>↖</td></tr> <tr><td>2:</td><td>9.4</td><td>↖</td></tr> <tr><td>3:</td><td>9.0</td><td>↗</td></tr> <tr><td>4:</td><td>9.3</td><td>→</td></tr> <tr><td>5:</td><td>5.4</td><td>↖</td></tr> <tr><td>6:</td><td>6.6</td><td>↖</td></tr> <tr><td>7:</td><td>7.6</td><td>↗</td></tr> <tr><td>8:</td><td>7.9</td><td>↖</td></tr> <tr><td>9:</td><td>9.5</td><td>↗</td></tr> <tr><td>10:</td><td>9.5</td><td>→</td></tr> <tr><td colspan="2"><b>Series</b></td><td><b>78.0</b></td></tr> <tr><td colspan="2"><b>Total</b></td><td><b>579.0</b></td></tr> </table>	1:	8.7	↖	2:	9.4	↖	3:	9.0	↗	4:	9.3	→	5:	5.4	↖	6:	6.6	↖	7:	7.6	↗	8:	7.9	↖	9:	9.5	↗	10:	9.5	→	<b>Series</b>		<b>78.0</b>	<b>Total</b>		<b>579.0</b>
51:	9.9	↖																																																																									
52:	10.4x	↗																																																																									
53:	10.2	↗																																																																									
54:	10.7x	↗																																																																									
55:	10.4x	↗																																																																									
56:	10.0	↗																																																																									
57:	9.1	↗																																																																									
58:	10.9x	↗																																																																									
59:	10.3x	↗																																																																									
60:	9.8	↗																																																																									
<b>Series</b>		<b>97.0</b>																																																																									
<b>Total</b>		<b>579.0</b>																																																																									
1:	8.7	↖																																																																									
2:	9.4	↖																																																																									
3:	9.0	↗																																																																									
4:	9.3	→																																																																									
5:	5.4	↖																																																																									
6:	6.6	↖																																																																									
7:	7.6	↗																																																																									
8:	7.9	↖																																																																									
9:	9.5	↗																																																																									
10:	9.5	→																																																																									
<b>Series</b>		<b>78.0</b>																																																																									
<b>Total</b>		<b>579.0</b>																																																																									
Sight Stand 	<table border="1" style="width:100%; border-collapse: collapse;"> <tr><td>11:</td><td>9.4</td><td>↖</td></tr> <tr><td>12:</td><td>9.3</td><td>↗</td></tr> <tr><td>13:</td><td>10.3x</td><td>→</td></tr> <tr><td>14:</td><td>10.5x</td><td>↗</td></tr> <tr><td>15:</td><td>9.5</td><td>→</td></tr> <tr><td colspan="2"><b>Series</b></td><td><b>47.0</b></td></tr> <tr><td colspan="2"><b>Total</b></td><td><b>579.0</b></td></tr> </table>	11:	9.4	↖	12:	9.3	↗	13:	10.3x	→	14:	10.5x	↗	15:	9.5	→	<b>Series</b>		<b>47.0</b>	<b>Total</b>		<b>579.0</b>	2. Series 40 Stand 	<table border="1" style="width:100%; border-collapse: collapse;"> <tr><td>1:</td><td>7.7</td><td>↗</td></tr> <tr><td>2:</td><td>8.9</td><td>↗</td></tr> <tr><td>3:</td><td>10.1</td><td>↗</td></tr> <tr><td>4:</td><td>9.8</td><td>↗</td></tr> <tr><td>5:</td><td>7.6</td><td>↗</td></tr> <tr><td>6:</td><td>8.2</td><td>↗</td></tr> <tr><td>7:</td><td>9.1</td><td>→</td></tr> <tr><td>8:</td><td>9.5</td><td>↘</td></tr> <tr><td>9:</td><td>9.9</td><td>↘</td></tr> <tr><td>10:</td><td>8.8</td><td>↗</td></tr> <tr><td colspan="2"><b>Series</b></td><td><b>84.0</b></td></tr> <tr><td colspan="2"><b>Total</b></td><td><b>663.0</b></td></tr> </table>	1:	7.7	↗	2:	8.9	↗	3:	10.1	↗	4:	9.8	↗	5:	7.6	↗	6:	8.2	↗	7:	9.1	→	8:	9.5	↘	9:	9.9	↘	10:	8.8	↗	<b>Series</b>		<b>84.0</b>	<b>Total</b>		<b>663.0</b>															
11:	9.4	↖																																																																									
12:	9.3	↗																																																																									
13:	10.3x	→																																																																									
14:	10.5x	↗																																																																									
15:	9.5	→																																																																									
<b>Series</b>		<b>47.0</b>																																																																									
<b>Total</b>		<b>579.0</b>																																																																									
1:	7.7	↗																																																																									
2:	8.9	↗																																																																									
3:	10.1	↗																																																																									
4:	9.8	↗																																																																									
5:	7.6	↗																																																																									
6:	8.2	↗																																																																									
7:	9.1	→																																																																									
8:	9.5	↘																																																																									
9:	9.9	↘																																																																									
10:	8.8	↗																																																																									
<b>Series</b>		<b>84.0</b>																																																																									
<b>Total</b>		<b>663.0</b>																																																																									

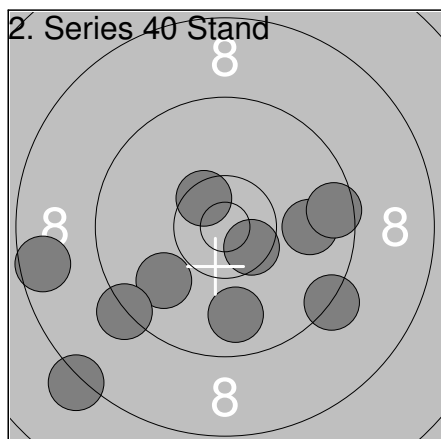

11:	9.3	↘
12:	10.5x	↗
13:	9.9	↙
14:	8.2	↙
15:	8.6	←
16:	9.9	→
17:	9.3	↙
18:	9.8	↘
19:	10.5x	↘
20:	9.6	→
Series	90.0	
Total	753.0	

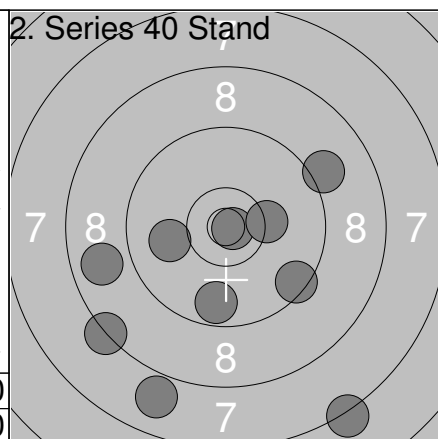

21:	10.8x	→
22:	8.3	↙
23:	9.5	↘
24:	7.9	↘
25:	9.7	↓
26:	10.3	→
27:	8.8	←
28:	10.0	←
29:	7.2	↘
30:	9.1	↗
Series	87.0	
Total	840.0	

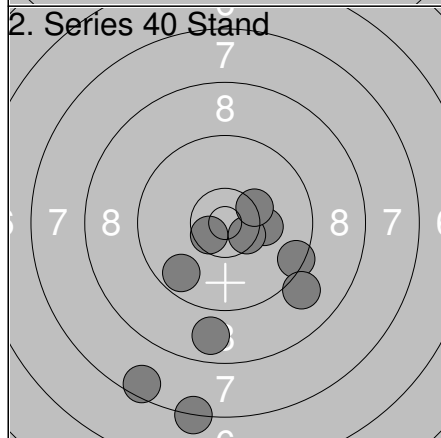

31:	10.6x	←
32:	7.5	↘
33:	9.5	↘
34:	10.2	→
35:	7.3	↘
36:	9.7	↙
37:	10.5x	↘
38:	9.0	↘
39:	8.8	↘
40:	10.3x	↗
Series	89.0	
Total	929.0	

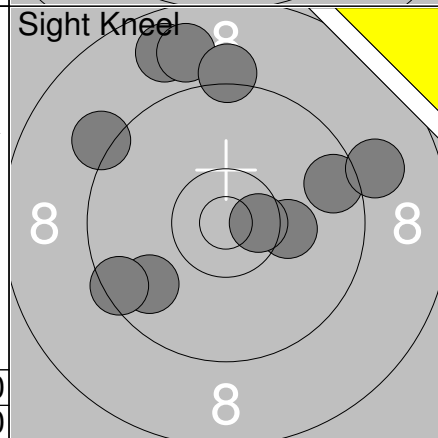

1:	9.2	↖
2:	8.8	↗
3:	8.9	↑
4:	9.8	↙
5:	9.6	→
6:	10.2	→
7:	10.6x	→
8:	9.2	↑
9:	9.1	→
10:	9.5	↙
Series	90.0	
Total	929.0	

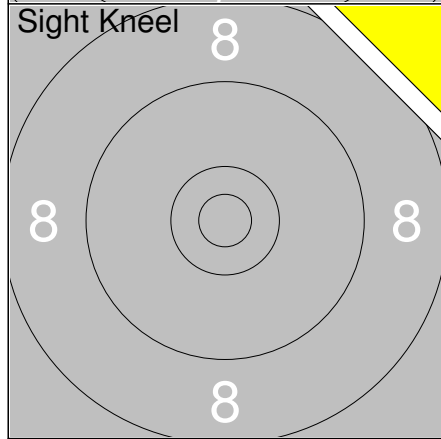

Series	0.0	
Total	929.0	

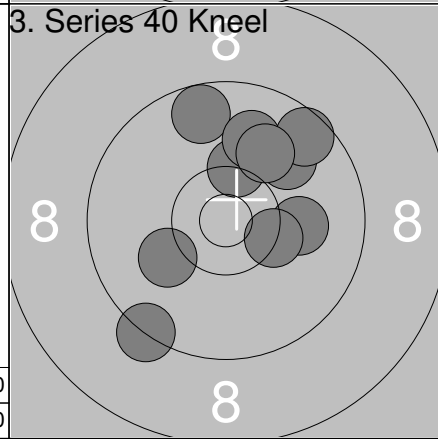

1:	9.6	↑
2:	9.9	↗
3:	10.1	→
4:	10.3x	↑
5:	9.9	↑
6:	10.1	↙
7:	9.6	↗
8:	10.0	↗
9:	9.3	↘
10:	10.3x	→
Series	95.0	
Total	1024.0	

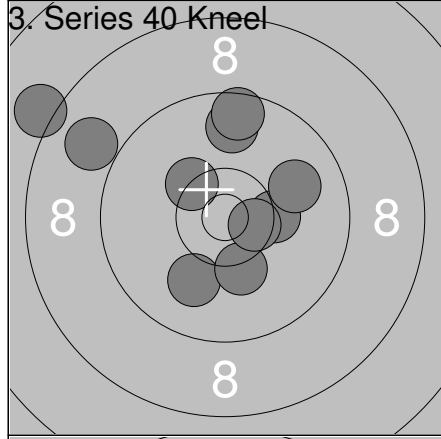

11:	8.1	↖
12:	9.7	↑
13:	10.3x	→
14:	10.0	↙
15:	10.3x	↗
16:	8.9	↗
17:	9.6	↑
18:	9.9	→
19:	10.2	↘
20:	10.5x	→
Series	93.0	
Total	1117.0	

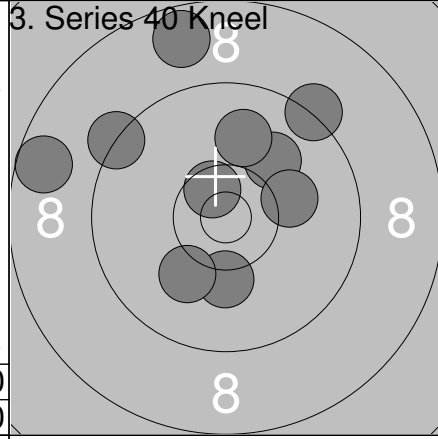

21:	9.3	↖
22:	10.1	↗
23:	10.1	→
24:	9.3	↗
25:	10.2	↓
26:	8.6	←
27:	10.1	↙
28:	8.7	↑
29:	10.6x	↖
30:	10.0	↑
Series	94.0	
Total	1211.0	

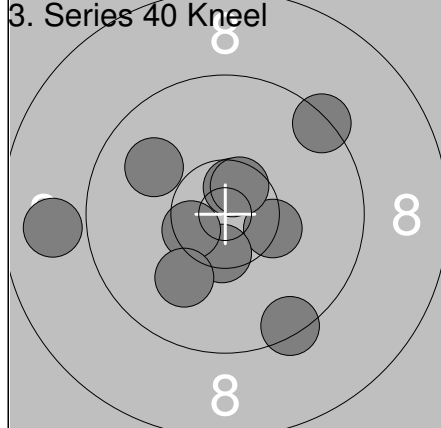

31:	10.6x	↑
32:	9.4	↘
33:	10.4x	→
34:	8.9	←
35:	9.9	↗
36:	10.6x	↗
37:	10.5x	↘
38:	9.4	↗
39:	10.5x	←
40:	10.1	↘
Series	95.0	
Total	1306.0	

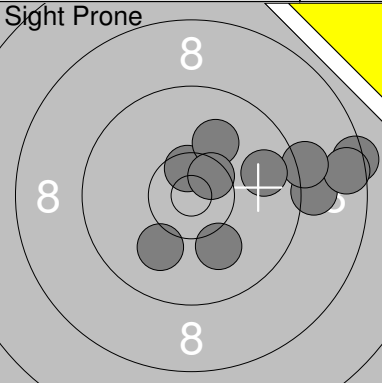
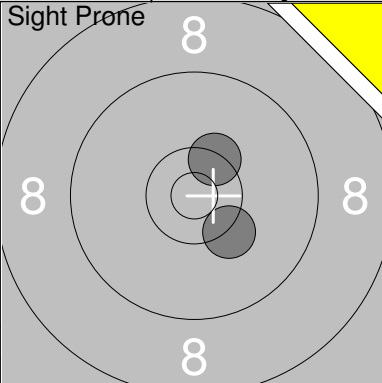
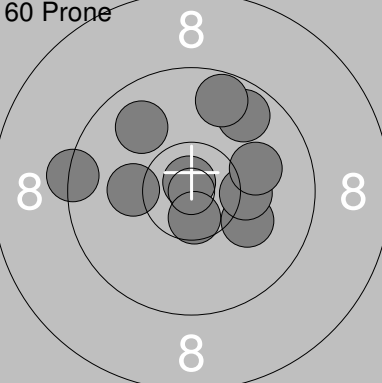
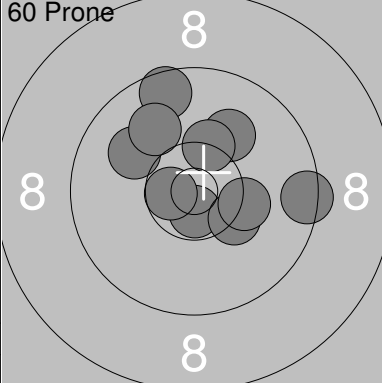
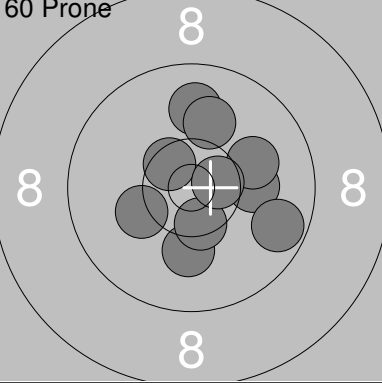
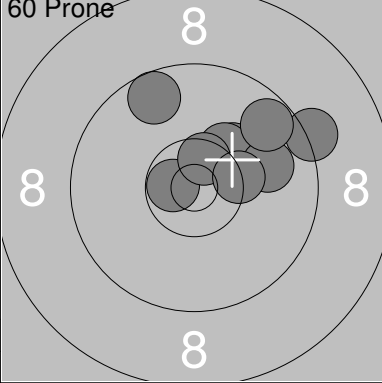
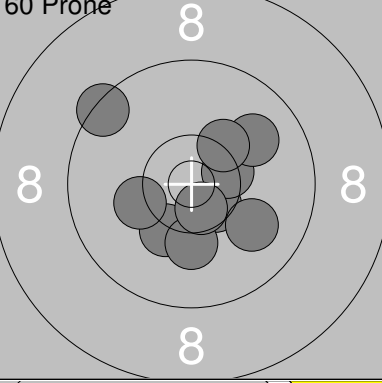
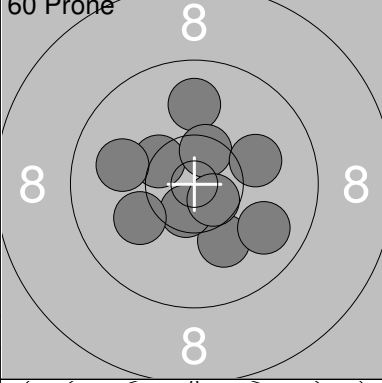
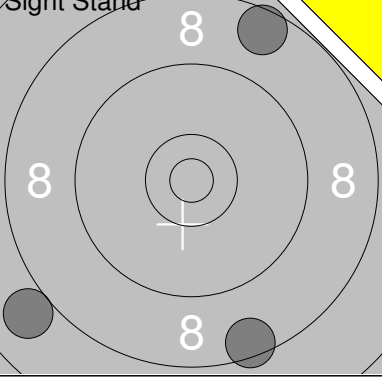
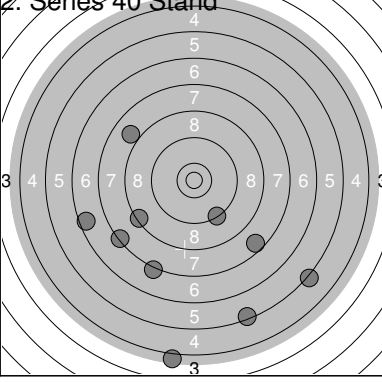
Relay	Lane	André Olsén																																																																									
S	13	Umeå	HJA Vb																																																																								
2014-04-13	Startskottet 2014	Umeå skytteallians																																																																									
Sight Prone	 <table border="1"> <tr><td>1:</td><td>8.4</td><td>→</td></tr> <tr><td>2:</td><td>9.1</td><td>→</td></tr> <tr><td>3:</td><td>8.6</td><td>→</td></tr> <tr><td>4:</td><td>9.2</td><td>→</td></tr> <tr><td>5:</td><td>9.8</td><td>→</td></tr> <tr><td>6:</td><td>10.5x</td><td>↑</td></tr> <tr><td>7:</td><td>10.1</td><td>↑</td></tr> <tr><td>8:</td><td>10.5x</td><td>↑</td></tr> <tr><td>9:</td><td>10.1</td><td>↓</td></tr> <tr><td>10:</td><td>10.0</td><td>↓</td></tr> <tr><td>Series</td><td>93.0</td><td></td></tr> <tr><td>Total</td><td>0.0</td><td></td></tr> </table>	1:	8.4	→	2:	9.1	→	3:	8.6	→	4:	9.2	→	5:	9.8	→	6:	10.5x	↑	7:	10.1	↑	8:	10.5x	↑	9:	10.1	↓	10:	10.0	↓	Series	93.0		Total	0.0		Sight Prone	 <table border="1"> <tr><td>11:</td><td>10.3</td><td>↓</td></tr> <tr><td>12:</td><td>10.4x</td><td>↑</td></tr> <tr><td>Series</td><td>20.0</td><td></td></tr> <tr><td>Total</td><td>0.0</td><td></td></tr> </table>	11:	10.3	↓	12:	10.4x	↑	Series	20.0		Total	0.0																									
1:	8.4	→																																																																									
2:	9.1	→																																																																									
3:	8.6	→																																																																									
4:	9.2	→																																																																									
5:	9.8	→																																																																									
6:	10.5x	↑																																																																									
7:	10.1	↑																																																																									
8:	10.5x	↑																																																																									
9:	10.1	↓																																																																									
10:	10.0	↓																																																																									
Series	93.0																																																																										
Total	0.0																																																																										
11:	10.3	↓																																																																									
12:	10.4x	↑																																																																									
Series	20.0																																																																										
Total	0.0																																																																										
60 Prone	 <table border="1"> <tr><td>1:</td><td>10.8x</td><td>↑</td></tr> <tr><td>2:</td><td>10.1</td><td>↓</td></tr> <tr><td>3:</td><td>10.6x</td><td>↓</td></tr> <tr><td>4:</td><td>10.2</td><td>↓</td></tr> <tr><td>5:</td><td>9.4</td><td>←</td></tr> <tr><td>6:</td><td>10.2</td><td>←</td></tr> <tr><td>7:</td><td>9.7</td><td>↑</td></tr> <tr><td>8:</td><td>10.0</td><td>→</td></tr> <tr><td>9:</td><td>9.9</td><td>→</td></tr> <tr><td>10:</td><td>9.7</td><td>↑</td></tr> <tr><td>Series</td><td>96.0</td><td></td></tr> <tr><td>Total</td><td>96.0</td><td></td></tr> </table>	1:	10.8x	↑	2:	10.1	↓	3:	10.6x	↓	4:	10.2	↓	5:	9.4	←	6:	10.2	←	7:	9.7	↑	8:	10.0	→	9:	9.9	→	10:	9.7	↑	Series	96.0		Total	96.0		60 Prone	 <table border="1"> <tr><td>11:</td><td>10.0</td><td>←</td></tr> <tr><td>12:</td><td>10.7x</td><td>↓</td></tr> <tr><td>13:</td><td>9.6</td><td>↑</td></tr> <tr><td>14:</td><td>10.3x</td><td>↓</td></tr> <tr><td>15:</td><td>10.1</td><td>↑</td></tr> <tr><td>16:</td><td>10.0</td><td>↑</td></tr> <tr><td>17:</td><td>10.3x</td><td>↑</td></tr> <tr><td>18:</td><td>9.5</td><td>→</td></tr> <tr><td>19:</td><td>10.6x</td><td>←</td></tr> <tr><td>20:</td><td>10.3</td><td>→</td></tr> <tr><td>Series</td><td>98.0</td><td></td></tr> <tr><td>Total</td><td>194.0</td><td></td></tr> </table>	11:	10.0	←	12:	10.7x	↓	13:	9.6	↑	14:	10.3x	↓	15:	10.1	↑	16:	10.0	↑	17:	10.3x	↑	18:	9.5	→	19:	10.6x	←	20:	10.3	→	Series	98.0		Total	194.0	
1:	10.8x	↑																																																																									
2:	10.1	↓																																																																									
3:	10.6x	↓																																																																									
4:	10.2	↓																																																																									
5:	9.4	←																																																																									
6:	10.2	←																																																																									
7:	9.7	↑																																																																									
8:	10.0	→																																																																									
9:	9.9	→																																																																									
10:	9.7	↑																																																																									
Series	96.0																																																																										
Total	96.0																																																																										
11:	10.0	←																																																																									
12:	10.7x	↓																																																																									
13:	9.6	↑																																																																									
14:	10.3x	↓																																																																									
15:	10.1	↑																																																																									
16:	10.0	↑																																																																									
17:	10.3x	↑																																																																									
18:	9.5	→																																																																									
19:	10.6x	←																																																																									
20:	10.3	→																																																																									
Series	98.0																																																																										
Total	194.0																																																																										
60 Prone	 <table border="1"> <tr><td>21:</td><td>9.9</td><td>↑</td></tr> <tr><td>22:</td><td>10.1</td><td>→</td></tr> <tr><td>23:</td><td>10.1</td><td>↑</td></tr> <tr><td>24:</td><td>10.5x</td><td>↑</td></tr> <tr><td>25:</td><td>10.1</td><td>↓</td></tr> <tr><td>26:</td><td>10.2</td><td>←</td></tr> <tr><td>27:</td><td>10.1</td><td>→</td></tr> <tr><td>28:</td><td>10.5x</td><td>↓</td></tr> <tr><td>29:</td><td>10.6x</td><td>→</td></tr> <tr><td>30:</td><td>9.7</td><td>↓</td></tr> <tr><td>Series</td><td>98.0</td><td></td></tr> <tr><td>Total</td><td>292.0</td><td></td></tr> </table>	21:	9.9	↑	22:	10.1	→	23:	10.1	↑	24:	10.5x	↑	25:	10.1	↓	26:	10.2	←	27:	10.1	→	28:	10.5x	↓	29:	10.6x	→	30:	9.7	↓	Series	98.0		Total	292.0		60 Prone	 <table border="1"> <tr><td>31:</td><td>10.2</td><td>↑</td></tr> <tr><td>32:</td><td>10.1</td><td>→</td></tr> <tr><td>33:</td><td>10.7x</td><td>←</td></tr> <tr><td>34:</td><td>10.3x</td><td>↑</td></tr> <tr><td>35:</td><td>9.6</td><td>↑</td></tr> <tr><td>36:</td><td>10.5x</td><td>↑</td></tr> <tr><td>37:</td><td>9.9</td><td>→</td></tr> <tr><td>38:</td><td>9.2</td><td>→</td></tr> <tr><td>39:</td><td>10.3x</td><td>→</td></tr> <tr><td>40:</td><td>9.7</td><td>↑</td></tr> <tr><td>Series</td><td>96.0</td><td></td></tr> <tr><td>Total</td><td>388.0</td><td></td></tr> </table>	31:	10.2	↑	32:	10.1	→	33:	10.7x	←	34:	10.3x	↑	35:	9.6	↑	36:	10.5x	↑	37:	9.9	→	38:	9.2	→	39:	10.3x	→	40:	9.7	↑	Series	96.0		Total	388.0	
21:	9.9	↑																																																																									
22:	10.1	→																																																																									
23:	10.1	↑																																																																									
24:	10.5x	↑																																																																									
25:	10.1	↓																																																																									
26:	10.2	←																																																																									
27:	10.1	→																																																																									
28:	10.5x	↓																																																																									
29:	10.6x	→																																																																									
30:	9.7	↓																																																																									
Series	98.0																																																																										
Total	292.0																																																																										
31:	10.2	↑																																																																									
32:	10.1	→																																																																									
33:	10.7x	←																																																																									
34:	10.3x	↑																																																																									
35:	9.6	↑																																																																									
36:	10.5x	↑																																																																									
37:	9.9	→																																																																									
38:	9.2	→																																																																									
39:	10.3x	→																																																																									
40:	9.7	↑																																																																									
Series	96.0																																																																										
Total	388.0																																																																										
60 Prone	 <table border="1"> <tr><td>41:</td><td>10.5x</td><td>↓</td></tr> <tr><td>42:</td><td>10.4x</td><td>→</td></tr> <tr><td>43:</td><td>9.4</td><td>↑</td></tr> <tr><td>44:</td><td>10.3</td><td>↓</td></tr> <tr><td>45:</td><td>10.2</td><td>↓</td></tr> <tr><td>46:</td><td>9.9</td><td>→</td></tr> <tr><td>47:</td><td>10.2</td><td>←</td></tr> <tr><td>48:</td><td>10.3x</td><td>↑</td></tr> <tr><td>49:</td><td>10.6x</td><td>↓</td></tr> <tr><td>50:</td><td>10.0</td><td>↓</td></tr> <tr><td>Series</td><td>98.0</td><td></td></tr> <tr><td>Total</td><td>486.0</td><td></td></tr> </table>	41:	10.5x	↓	42:	10.4x	→	43:	9.4	↑	44:	10.3	↓	45:	10.2	↓	46:	9.9	→	47:	10.2	←	48:	10.3x	↑	49:	10.6x	↓	50:	10.0	↓	Series	98.0		Total	486.0		60 Prone	 <table border="1"> <tr><td>51:</td><td>10.1</td><td>↓</td></tr> <tr><td>52:</td><td>9.9</td><td>↑</td></tr> <tr><td>53:</td><td>10.4x</td><td>↑</td></tr> <tr><td>54:</td><td>10.5x</td><td>↑</td></tr> <tr><td>55:</td><td>10.6x</td><td>↓</td></tr> <tr><td>56:</td><td>9.9</td><td>↓</td></tr> <tr><td>57:</td><td>10.0</td><td>←</td></tr> <tr><td>58:</td><td>10.1</td><td>→</td></tr> <tr><td>59:</td><td>10.6x</td><td>↓</td></tr> <tr><td>60:</td><td>10.1</td><td>←</td></tr> <tr><td>Series</td><td>98.0</td><td></td></tr> <tr><td>Total</td><td>584.0</td><td></td></tr> </table>	51:	10.1	↓	52:	9.9	↑	53:	10.4x	↑	54:	10.5x	↑	55:	10.6x	↓	56:	9.9	↓	57:	10.0	←	58:	10.1	→	59:	10.6x	↓	60:	10.1	←	Series	98.0		Total	584.0	
41:	10.5x	↓																																																																									
42:	10.4x	→																																																																									
43:	9.4	↑																																																																									
44:	10.3	↓																																																																									
45:	10.2	↓																																																																									
46:	9.9	→																																																																									
47:	10.2	←																																																																									
48:	10.3x	↑																																																																									
49:	10.6x	↓																																																																									
50:	10.0	↓																																																																									
Series	98.0																																																																										
Total	486.0																																																																										
51:	10.1	↓																																																																									
52:	9.9	↑																																																																									
53:	10.4x	↑																																																																									
54:	10.5x	↑																																																																									
55:	10.6x	↓																																																																									
56:	9.9	↓																																																																									
57:	10.0	←																																																																									
58:	10.1	→																																																																									
59:	10.6x	↓																																																																									
60:	10.1	←																																																																									
Series	98.0																																																																										
Total	584.0																																																																										
Sight Stand	 <table border="1"> <tr><td>1:</td><td>8.6</td><td>↑</td></tr> <tr><td>2:</td><td>8.5</td><td>↓</td></tr> <tr><td>3:</td><td>8.0</td><td>←</td></tr> <tr><td>Series</td><td>24.0</td><td></td></tr> <tr><td>Total</td><td>584.0</td><td></td></tr> </table>	1:	8.6	↑	2:	8.5	↓	3:	8.0	←	Series	24.0		Total	584.0		2. Series 40 Stand	 <table border="1"> <tr><td>1:</td><td>5.4</td><td>↓</td></tr> <tr><td>2:</td><td>7.6</td><td>↓</td></tr> <tr><td>3:</td><td>4.1</td><td>↓</td></tr> <tr><td>4:</td><td>9.4</td><td>↓</td></tr> <tr><td>5:</td><td>5.2</td><td>↓</td></tr> <tr><td>6:</td><td>8.4</td><td>←</td></tr> <tr><td>7:</td><td>6.6</td><td>←</td></tr> <tr><td>8:</td><td>7.4</td><td>←</td></tr> <tr><td>9:</td><td>7.2</td><td>↓</td></tr> <tr><td>10:</td><td>8.0</td><td>↑</td></tr> <tr><td>Series</td><td>66.0</td><td></td></tr> <tr><td>Total</td><td>650.0</td><td></td></tr> </table>	1:	5.4	↓	2:	7.6	↓	3:	4.1	↓	4:	9.4	↓	5:	5.2	↓	6:	8.4	←	7:	6.6	←	8:	7.4	←	9:	7.2	↓	10:	8.0	↑	Series	66.0		Total	650.0																						
1:	8.6	↑																																																																									
2:	8.5	↓																																																																									
3:	8.0	←																																																																									
Series	24.0																																																																										
Total	584.0																																																																										
1:	5.4	↓																																																																									
2:	7.6	↓																																																																									
3:	4.1	↓																																																																									
4:	9.4	↓																																																																									
5:	5.2	↓																																																																									
6:	8.4	←																																																																									
7:	6.6	←																																																																									
8:	7.4	←																																																																									
9:	7.2	↓																																																																									
10:	8.0	↑																																																																									
Series	66.0																																																																										
Total	650.0																																																																										



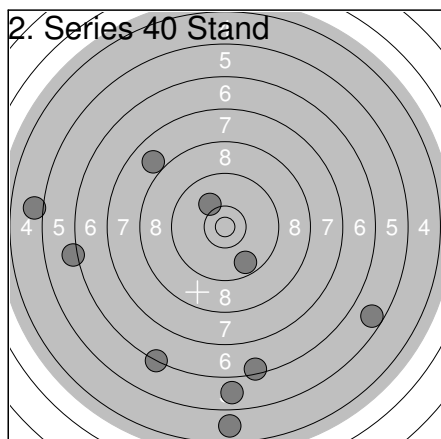

11:	4.8	↓
12:	5.8	↓
13:	6.2	←
14:	5.6	↘
15:	6.3	↘
16:	10.1	↗
17:	6.5	↓
18:	5.0	↑
19:	7.9	↗
20:	9.7	↓

Series	63.0
Total	713.0

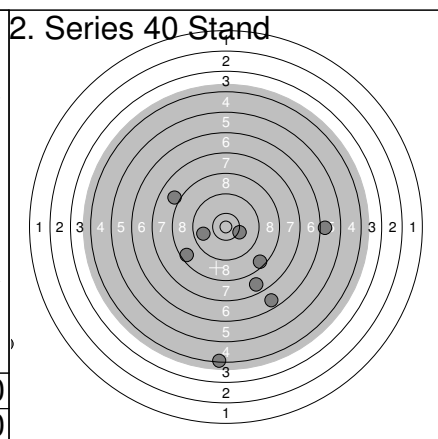

21:	8.6	↘
22:	7.8	↘
23:	9.8	←
24:	0.0	←
25:	8.1	↗
26:	10.2	↘
27:	4.4	↓
28:	8.6	←
29:	6.1	→
30:	6.7	↓

Series	66.0
Total	779.0

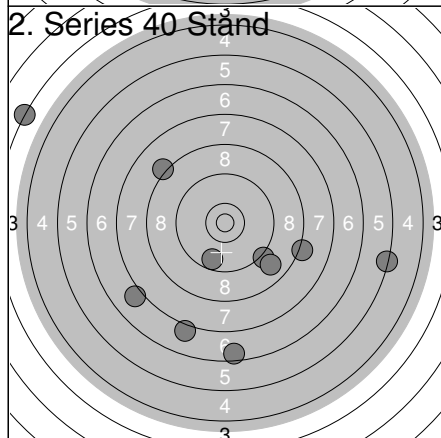

31:	8.2	↗
32:	7.1	↘
33:	6.5	↓
34:	8.2	→
35:	7.1	↓
36:	3.3	↗
37:	5.4	→
38:	9.2	↘
39:	8.9	↘
40:	9.7	↓

Series	70.0
Total	849.0

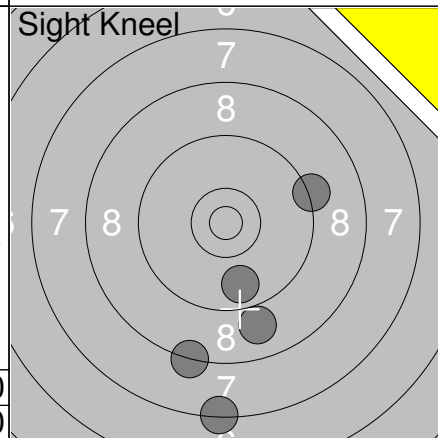

1:	8.9	↓
2:	7.3	↓
3:	9.2	→
4:	8.3	↓
5:	9.8	↓

Series	41.0
Total	849.0

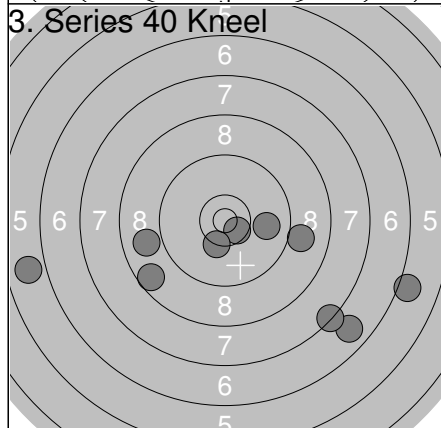

1:	10.6x	↘
2:	5.9	←
3:	8.6	↘
4:	10.3x	↓
5:	9.9	→
6:	6.8	↘
7:	7.3	↘
8:	9.0	→
9:	8.9	←
10:	6.1	↘

Series	78.0
Total	927.0

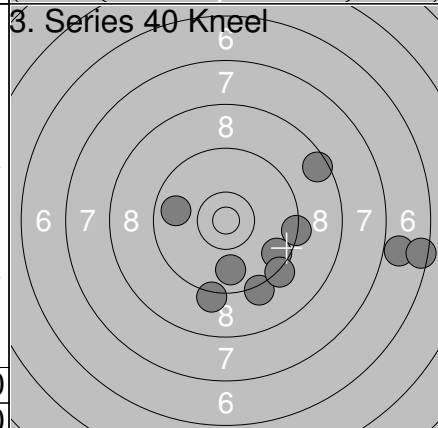

11:	6.9	→
12:	9.2	↓
13:	9.2	↓
14:	8.5	↗
15:	9.6	↘
16:	9.3	→
17:	9.8	↓
18:	9.3	↓
19:	6.5	→
20:	9.8	←

Series	83.0
Total	1010.0

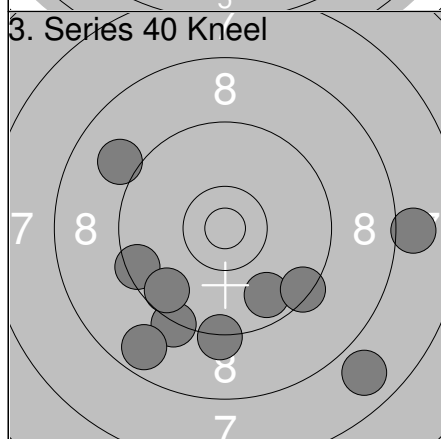

21:	9.3	↓
22:	9.3	↓
23:	9.5	←
24:	9.6	↘
25:	9.7	↘
26:	9.0	↗
27:	9.4	↘
28:	8.7	↘
29:	8.0	→
30:	7.8	↓

Series	86.0
Total	1096.0

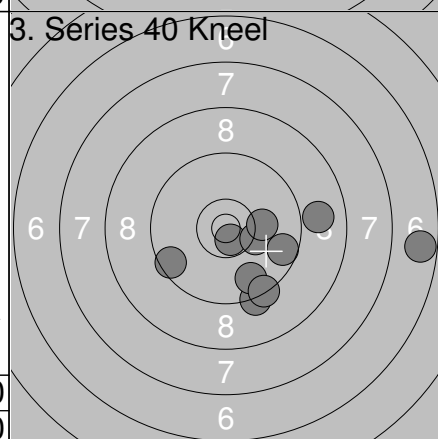

31:	10.7x	↓
32:	9.3	↓
33:	10.3	→
34:	9.6	→
35:	9.5	↘
36:	9.7	↘
37:	8.9	→
38:	10.1	→
39:	6.7	→
40:	9.4	↓

Series	89.0
Total	1185.0

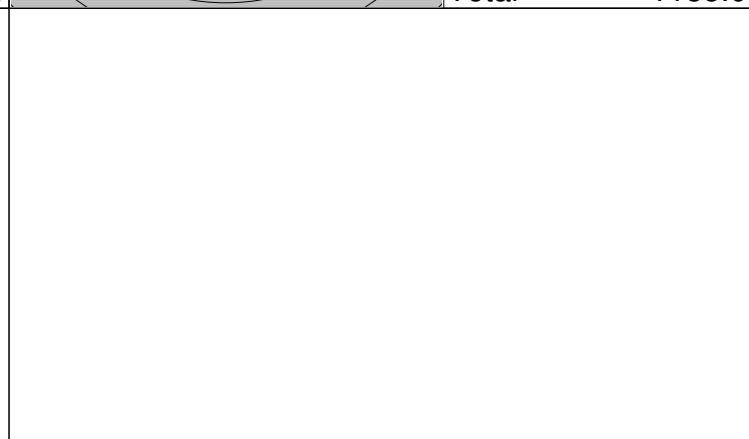
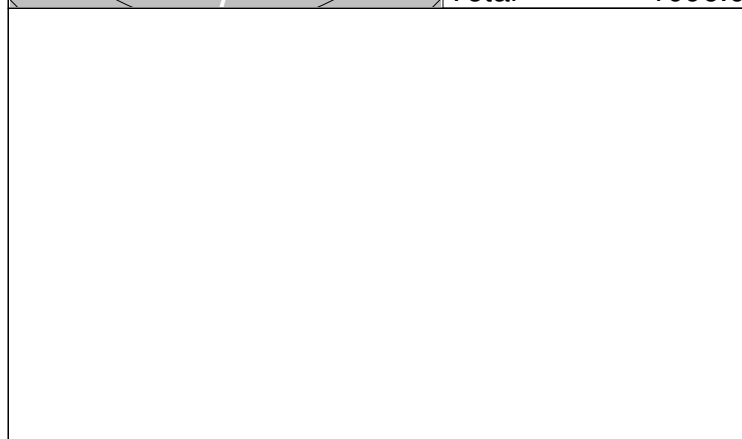

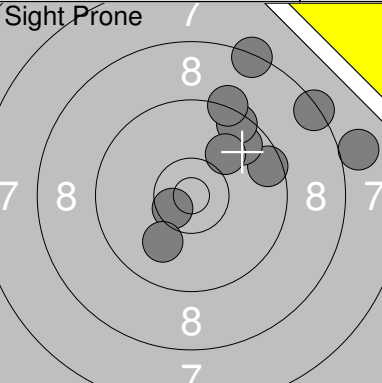
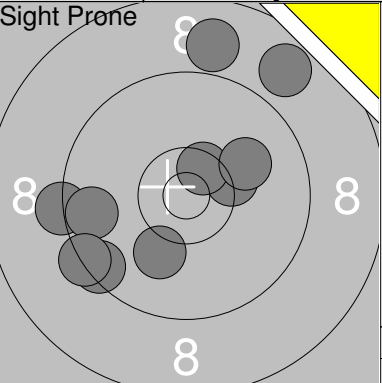
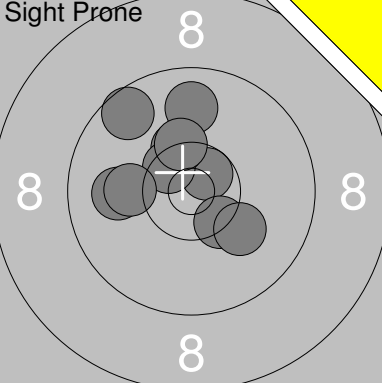
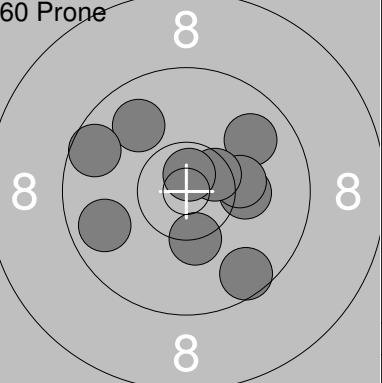
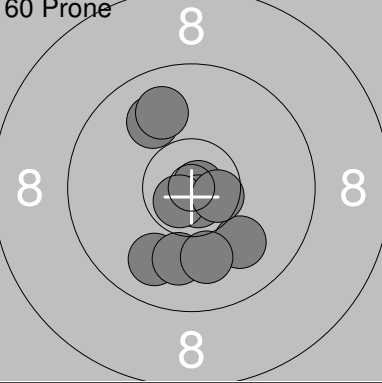
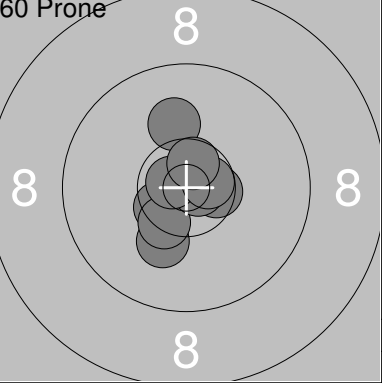
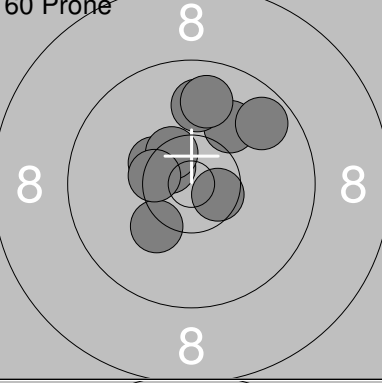
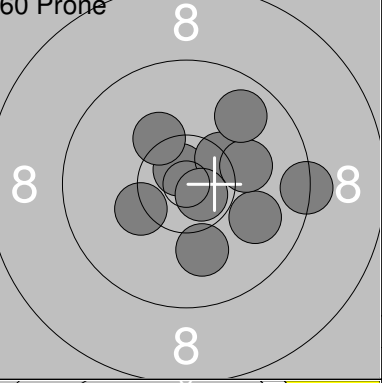
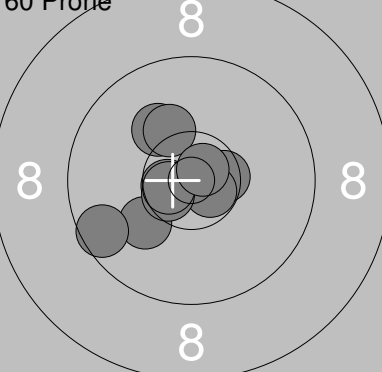
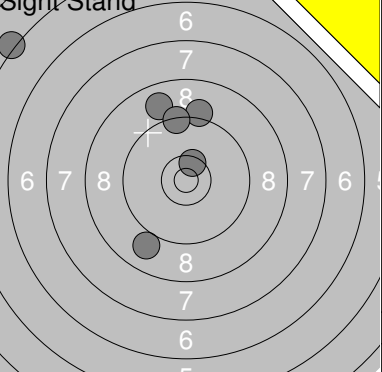
Relay	Lane	Lars Möllsten	
S	14	Umeå	S Vb
2014-04-13	Startskottet 2014	Umeå skytteallians	
Sight Prone 	1: 9.5 →	Sight Prone 	11: 8.9 ↑
	2: 8.4 →		12: 8.8 ↗
	3: 8.0 →		13: 9.3 ←
	4: 9.7 ↗		14: 9.7 ←
	5: 8.4 ↑		15: 9.5 ↘
	6: 9.5 ↗		16: 9.3 ↘
	7: 10.0 ↗		17: 10.3x →
	8: 10.6x ←		18: 10.1 ↓
	9: 10.0 ↓		19: 10.5x ↗
	10: 9.3 ↑		20: 10.1 ↗
	Series 90.0		Series 92.0
	Total 0.0		Total 0.0
Sight Prone 	21: 10.6x ↗	60 Prone 	1: 9.6 ↓
	22: 9.8 ↑		2: 10.2 ↓
	23: 9.6 ↗		3: 9.9 ↗
	24: 10.3x ↗		4: 10.2 →
	25: 10.4x ↓		5: 10.5x ↗
	26: 10.0 ←		6: 10.7x ↑
	27: 10.1 ↓		7: 10.3x ↓
	28: 10.5x ↗		8: 9.9 ↗
	29: 10.1 ←		9: 9.6 ↗
	30: 10.3x ↗		10: 9.8 ←
	Series 98.0		Series 95.0
	Total 0.0		Total 95.0
60 Prone 	11: 9.9 ↗	60 Prone 	21: 10.5x →
	12: 10.9x →		22: 10.5x ↘
	13: 10.7x ↓		23: 10.2 ↓
	14: 10.0 ↓		24: 10.4x ↘
	15: 10.7x ↘		25: 10.7x ↗
	16: 9.9 ↘		26: 10.8x →
	17: 9.9 ↗		27: 10.1 ↑
	18: 10.6x →		28: 10.7x ↗
	19: 10.0 ↓		29: 10.7x →
	20: 10.0 ↓		30: 10.6x ↑
	Series 97.0		Series 100.0
	Total 192.0		Total 292.0
60 Prone 	31: 10.0 ↗	60 Prone 	41: 10.1 ↓
	32: 9.7 ↗		42: 9.9 ↓
	33: 10.4x ↗		43: 10.7x ↗
	34: 10.2 ←		44: 9.3 →
	35: 9.9 ↑		45: 10.4x ↗
	36: 10.6x ↗		46: 10.1 →
	37: 9.8 ↗		47: 10.2 ↗
	38: 10.5x ↗		48: 10.7x ↓
	39: 10.4x ←		49: 9.8 ↗
	40: 10.6x →		50: 10.3 ←
	Series 97.0		Series 97.0
	Total 389.0		Total 486.0
60 Prone 	51: 10.5x →	Sight Stand 	1: 8.9 ↑
	52: 10.1 ↗		2: 5.2 ↗
	53: 10.6x ←		3: 9.2 ↑
	54: 10.7x ↓		4: 9.0 ↘
	55: 10.1 ↘		5: 10.5x ↑
	56: 9.6 ↘		6: 9.3 ↑
	57: 10.2 ↗		
	58: 10.6x ↘		
	59: 10.6x ←		
	60: 10.7x ↗		
	Series 99.0		Series 50.0
	Total 585.0		Total 585.0

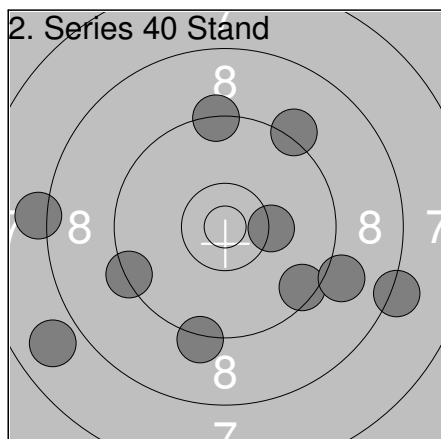

1:	10.3	→
2:	9.4	↙
3:	9.5	↘
4:	9.1	→
5:	7.9	↙
6:	8.2	→
7:	9.2	↘
8:	9.3	↑
9:	9.2	↗
10:	8.2	←
Series	87.0	
Total	672.0	

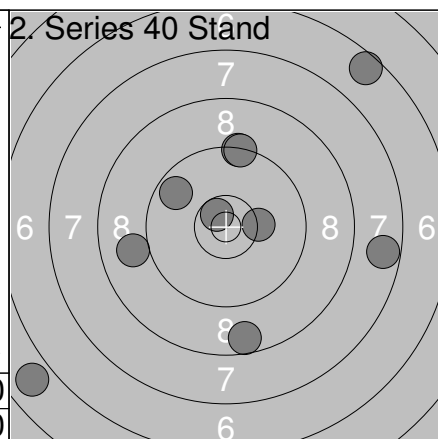

11:	5.9	↙
12:	9.0	←
13:	9.3	↑
14:	7.7	→
15:	6.6	↗
16:	10.6x	↗
17:	9.7	↗
18:	8.6	↓
19:	9.3	↑
20:	10.3	→
Series	82.0	
Total	754.0	

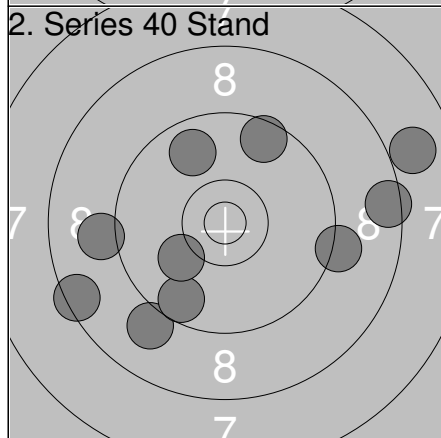

21:	8.5	←
22:	8.5	→
23:	9.6	↗
24:	9.0	↘
25:	9.2	→
26:	9.6	↘
27:	7.9	↗
28:	9.1	←
29:	10.1	↙
30:	9.8	↑
Series	87.0	
Total	841.0	

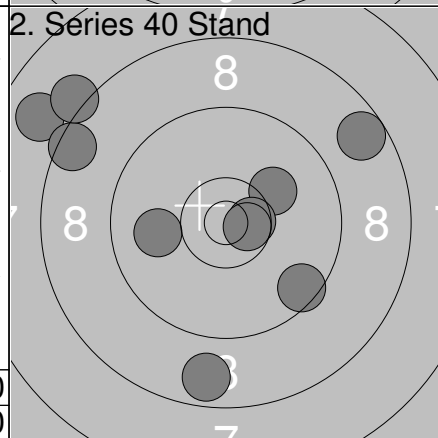

31:	8.7	↗
32:	10.1	↗
33:	7.9	↗
34:	8.5	↗
35:	10.6x	→
36:	10.0	←
37:	10.6x	→
38:	8.7	↓
39:	9.5	↘
40:	8.2	↗
Series	88.0	
Total	929.0	

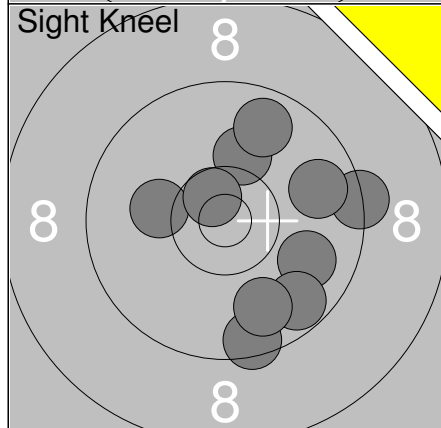

1:	9.9	→
2:	10.1	↑
3:	9.3	→
4:	9.5	↓
5:	9.8	↑
6:	9.8	→
7:	9.7	↘
8:	10.2	←
9:	9.8	↘
10:	10.6x	↗
Series	93.0	
Total	929.0	

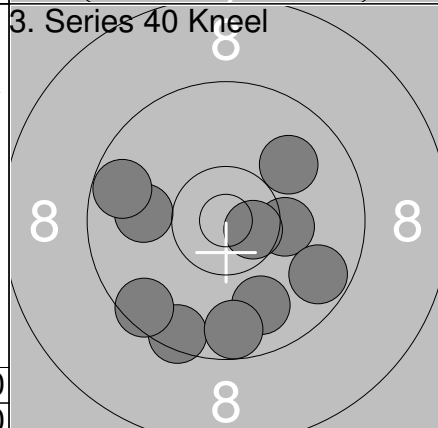

1:	9.5	↓
2:	9.5	↘
3:	10.0	←
4:	10.2	→
5:	10.0	↗
6:	9.7	↘
7:	9.9	↘
8:	10.6x	→
9:	9.7	←
10:	9.7	↓
Series	94.0	
Total	1023.0	

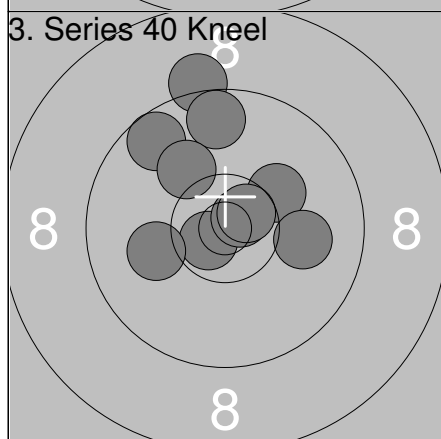

11:	10.2	↗
12:	9.2	↑
13:	10.7x	↙
14:	10.7x	↗
15:	10.1	←
16:	9.6	↗
17:	10.6x	↗
18:	9.7	↑
19:	10.0	→
20:	10.1	↗
Series	97.0	
Total	1120.0	

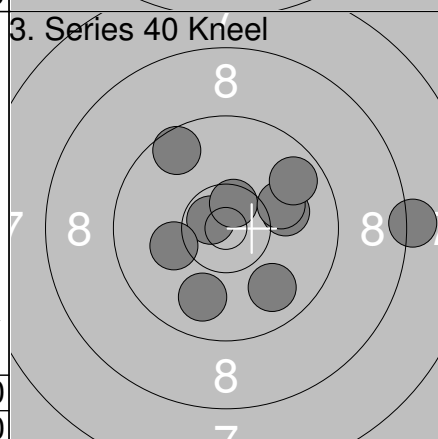

21:	9.8	↘
22:	9.9	↘
23:	9.6	↗
24:	10.0	→
25:	10.7x	↙
26:	10.6x	↑
27:	8.2	→
28:	10.1	←
29:	10.1	↗
30:	9.7	↗
Series	94.0	
Total	1214.0	

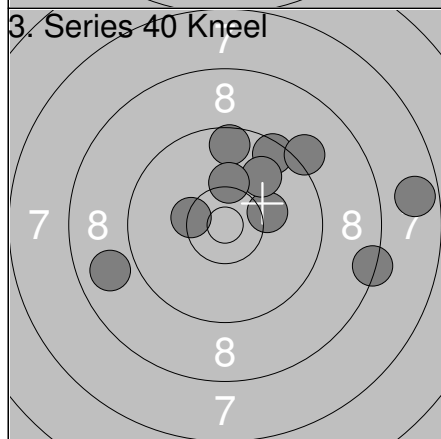

31:	8.9	←
32:	7.7	→
33:	9.5	↗
34:	10.2	→
35:	9.9	↗
36:	9.6	↑
37:	8.4	→
38:	9.2	↗
39:	10.4x	←
40:	10.2	↑
Series	89.0	
Total	1303.0	

Relay	Lane	Jörgen Pålsson			
S	15	Umeå	S Vb		
2014-04-13	Startskottet 2014	Umeå skytteallians			
Sight Prone	7	1: 7.6 ↗ 2: 9.4 → 3: 7.9 → 4: 8.4 → 5: 9.8 → 6: 10.6x ↗ 7: 10.2 ↗ 8: 10.2 ↘ 9: 10.0 → 10: 9.7 ↘	Sight Prone	8	11: 10.2 ↘ 12: 10.1 → 13: 10.1 → 14: 10.4x ↙ 15: 10.0 ↗ 16: 10.0 ↘ 17: 9.9 ↙ 18: 9.6 ↘ 19: 10.2 ↗
		Series 89.0 Total 0.0			Series 88.0 Total 0.0
60 Prone	8	1: 9.2 ↘ 2: 10.3 ↘ 3: 10.4x ↘ 4: 10.8x ↘ 5: 10.5x ↗ 6: 10.8x ↘ 7: 10.6x ↘ 8: 10.3 ↗ 9: 10.3x ↘ 10: 10.0 ↘	60 Prone	8	11: 9.9 ← 12: 10.0 ↙ 13: 10.3x ↗ 14: 9.9 ↘ 15: 9.7 ↙ 16: 10.1 ↘ 17: 9.8 ↗ 18: 10.0 → 19: 9.8 ↗ 20: 10.3x ↙
		Series 99.0 Total 99.0			Series 95.0 Total 194.0
60 Prone	8	21: 10.5x ↗ 22: 10.2 ↘ 23: 10.1 → 24: 10.2 ↗ 25: 9.7 ↘ 26: 10.2 ↙ 27: 10.5x ↗ 28: 10.4x ↙ 29: 9.9 ↗ 30: 9.9 ↙	60 Prone	8	31: 10.7x ↗ 32: 10.2 ← 33: 10.8x ↗ 34: 9.9 ↗ 35: 10.3x → 36: 10.1 ↘ 37: 9.8 ← 38: 10.0 → 39: 10.7x ↗ 40: 9.7 ↗
		Series 97.0 Total 291.0			Series 97.0 Total 388.0
60 Prone	8	41: 9.6 ↘ 42: 10.2 ↘ 43: 10.7x ↗ 44: 10.7x ↘ 45: 10.2 ↗ 46: 10.8x ↗ 47: 10.2 → 48: 9.8 ↗ 49: 9.9 ↗ 50: 8.9 →	60 Prone	8	51: 9.7 ↘ 52: 10.1 ↘ 53: 10.3 ← 54: 10.0 ↘ 55: 9.6 ↘ 56: 10.9x ← 57: 9.4 ↗ 58: 10.4x ↙ 59: 10.7x → 60: 10.0 ↗
		Series 95.0 Total 483.0			Series 97.0 Total 580.0
Sight Stand	8	1: 9.3 ↗ 2: 9.8 ← 3: 9.5 ↘ 4: 10.7x ↘ 5: 8.8 ↘ 6: 8.9 ↘ 7: 10.6x ↘	2. Series 40 Stand	8	1: 10.7x ← 2: 9.5 ↗ 3: 10.2 ↙ 4: 9.8 ↗ 5: 9.9 ↗ 6: 9.0 ↗ 7: 9.7 ↗ 8: 10.0 ↗ 9: 9.5 ↘ 10: 9.9 ↙
		Series 63.0 Total 580.0			Series 93.0 Total 673.0

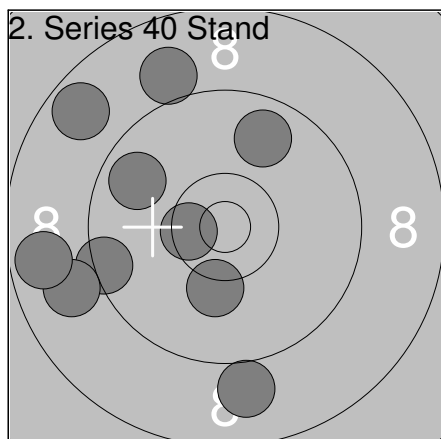

11:	9.4	←
12:	9.0	↓
13:	8.7	↗
14:	10.2	↓
15:	9.0	←
16:	8.7	←
17:	9.0	↗
18:	10.5x	←
19:	9.8	↗
20:	9.8	↗
Series		90.0
Total		763.0

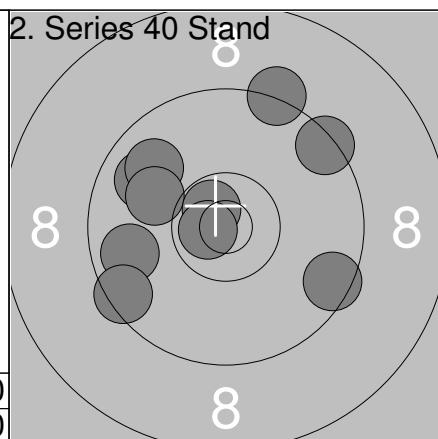

21:	9.8	↗
22:	9.8	↗
23:	9.5	↘
24:	9.8	←
25:	9.4	↗
26:	10.0	←
27:	9.5	↘
28:	9.3	↗
29:	10.7x	↗
30:	10.7x	←
Series		93.0
Total		856.0

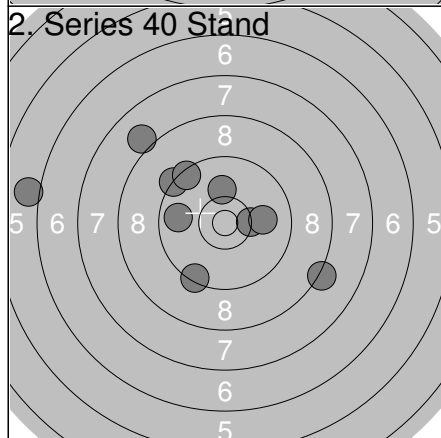

31:	6.0	←
32:	9.4	↓
33:	10.3x	→
34:	8.0	↗
35:	9.3	↗
36:	10.0	→
37:	8.2	↘
38:	9.4	↗
39:	10.1	↑
40:	9.8	←
Series		88.0
Total		944.0

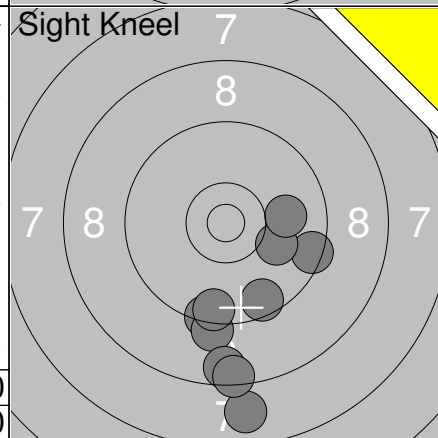

1:	9.4	↓
2:	9.5	→
3:	10.1	→
4:	9.2	↓
5:	9.6	↓
6:	7.9	↓
7:	8.6	↓
8:	9.5	↓
9:	10.0	→
10:	8.4	↓
Series		88.0
Total		944.0

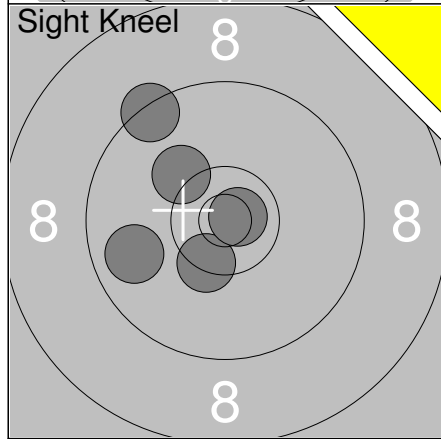

11:	10.4x	↓
12:	9.4	↗
13:	10.8x	→
14:	9.8	←
15:	10.2	↗
Series		48.0
Total		944.0

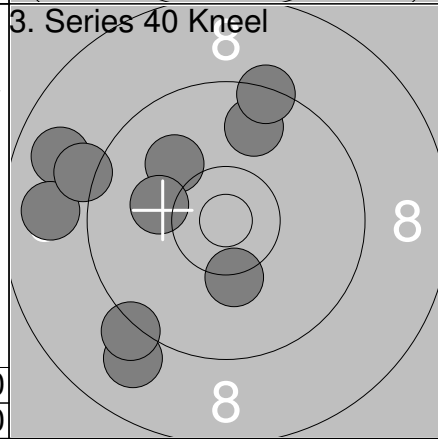

1:	10.0	↗
2:	10.3	↓
3:	8.8	↖
4:	9.8	↑
5:	9.0	↘
6:	8.9	←
7:	9.4	↑
8:	10.1	←
9:	9.2	↖
10:	9.2	↘
Series		91.0
Total		1035.0

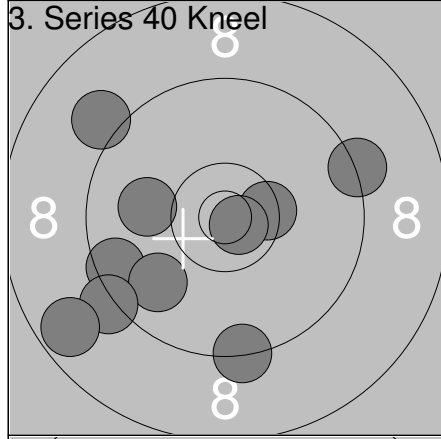

11:	9.5	←
12:	10.4x	→
13:	9.8	↘
14:	9.3	→
15:	9.2	↘
16:	10.8x	↘
17:	10.0	←
18:	9.1	↗
19:	8.7	↘
20:	9.3	↓
Series		92.0
Total		1127.0

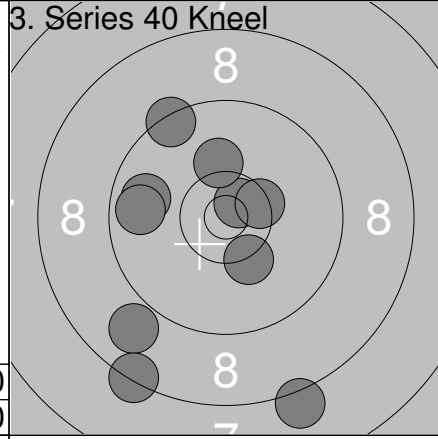

21:	10.7x	↗
22:	9.4	↗
23:	9.8	←
24:	10.2	↑
25:	10.3	↘
26:	10.4x	→
27:	9.7	←
28:	8.9	↘
29:	8.1	↓
30:	8.3	↓
Series		91.0
Total		1218.0

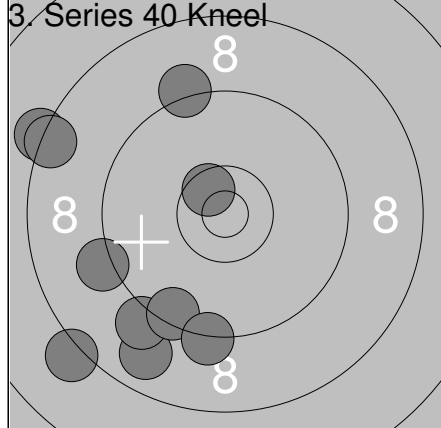

31:	9.2	↑
32:	8.2	↘
33:	8.8	↘
34:	9.2	←
35:	8.3	↖
36:	8.4	↗
37:	9.1	↘
38:	10.6x	↗
39:	9.4	↓
40:	9.3	↓
Series		87.0
Total		1305.0

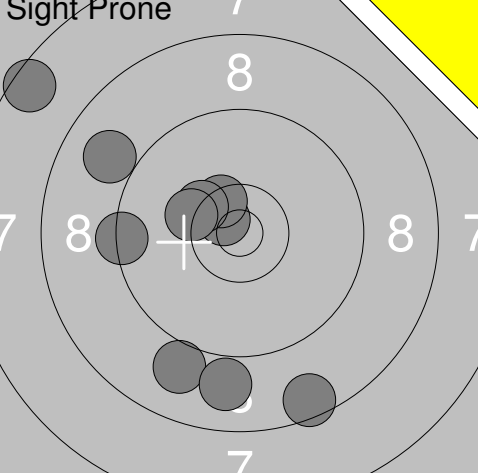
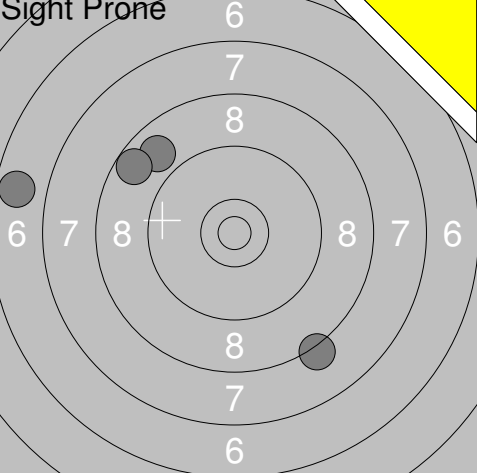
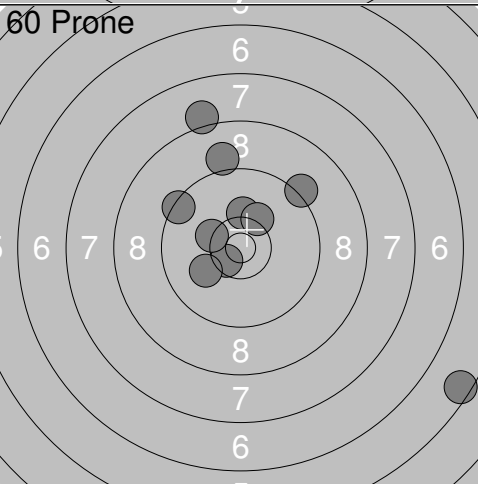
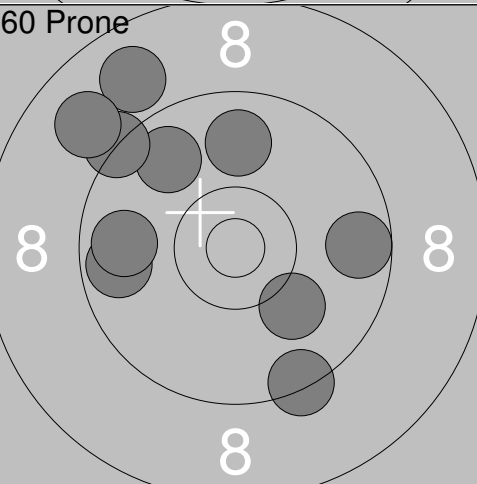
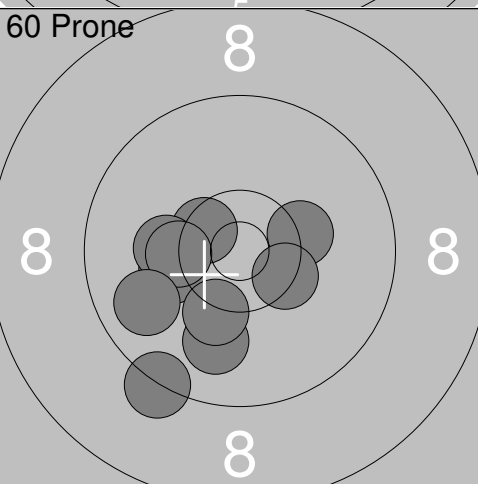
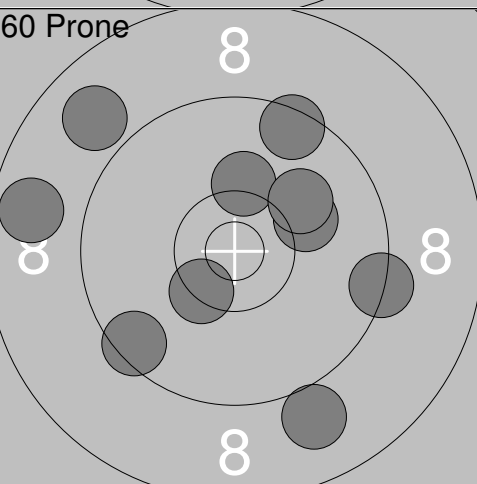
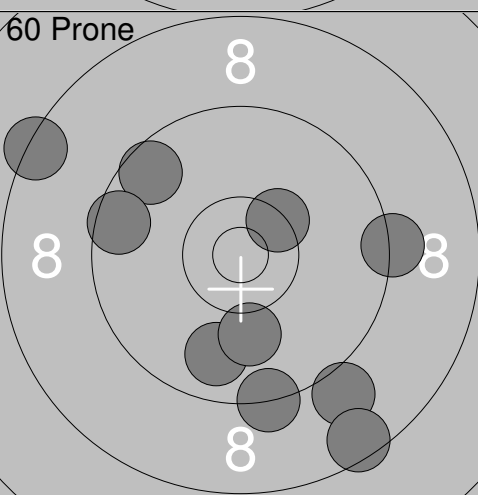
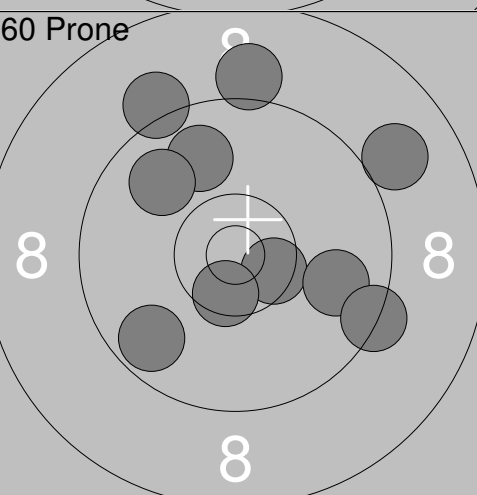

 <p>Sight Prone</p>	<table border="1" style="width:100%; border-collapse: collapse;"> <tr><td>1:</td><td>7.5</td><td>↗</td></tr> <tr><td>2:</td><td>9.4</td><td>←</td></tr> <tr><td>3:</td><td>8.9</td><td>↗</td></tr> <tr><td>4:</td><td>10.7x</td><td>↗</td></tr> <tr><td>5:</td><td>9.0</td><td>↓</td></tr> <tr><td>6:</td><td>10.5x</td><td>↗</td></tr> <tr><td>7:</td><td>8.5</td><td>↓</td></tr> <tr><td>8:</td><td>10.3x</td><td>↗</td></tr> <tr><td>9:</td><td>8.9</td><td>↓</td></tr> <tr><td>10:</td><td>10.3</td><td>←</td></tr> <tr><td colspan="2">Series</td><td>89.0</td></tr> <tr><td colspan="2">Total</td><td>0.0</td></tr> </table>	1:	7.5	↗	2:	9.4	←	3:	8.9	↗	4:	10.7x	↗	5:	9.0	↓	6:	10.5x	↗	7:	8.5	↓	8:	10.3x	↗	9:	8.9	↓	10:	10.3	←	Series		89.0	Total		0.0	 <p>Sight Prone</p>	<table border="1" style="width:100%; border-collapse: collapse;"> <tr><td>11:</td><td>8.8</td><td>↗</td></tr> <tr><td>12:</td><td>8.2</td><td>↓</td></tr> <tr><td>13:</td><td>8.6</td><td>↗</td></tr> <tr><td>14:</td><td>6.7</td><td>←</td></tr> <tr><td colspan="2">Series</td><td>30.0</td></tr> <tr><td colspan="2">Total</td><td>0.0</td></tr> </table>	11:	8.8	↗	12:	8.2	↓	13:	8.6	↗	14:	6.7	←	Series		30.0	Total		0.0																		
1:	7.5	↗																																																																									
2:	9.4	←																																																																									
3:	8.9	↗																																																																									
4:	10.7x	↗																																																																									
5:	9.0	↓																																																																									
6:	10.5x	↗																																																																									
7:	8.5	↓																																																																									
8:	10.3x	↗																																																																									
9:	8.9	↓																																																																									
10:	10.3	←																																																																									
Series		89.0																																																																									
Total		0.0																																																																									
11:	8.8	↗																																																																									
12:	8.2	↓																																																																									
13:	8.6	↗																																																																									
14:	6.7	←																																																																									
Series		30.0																																																																									
Total		0.0																																																																									
 <p>60 Prone</p>	<table border="1" style="width:100%; border-collapse: collapse;"> <tr><td>1:</td><td>10.6x</td><td>↙</td></tr> <tr><td>2:</td><td>9.4</td><td>↗</td></tr> <tr><td>3:</td><td>8.1</td><td>↗</td></tr> <tr><td>4:</td><td>10.1</td><td>↙</td></tr> <tr><td>5:</td><td>10.2</td><td>↑</td></tr> <tr><td>6:</td><td>10.3x</td><td>↙</td></tr> <tr><td>7:</td><td>9.2</td><td>↗</td></tr> <tr><td>8:</td><td>10.3</td><td>↗</td></tr> <tr><td>9:</td><td>5.5</td><td>↘</td></tr> <tr><td>10:</td><td>9.1</td><td>↑</td></tr> <tr><td colspan="2">Series</td><td>90.0</td></tr> <tr><td colspan="2">Total</td><td>90.0</td></tr> </table>	1:	10.6x	↙	2:	9.4	↗	3:	8.1	↗	4:	10.1	↙	5:	10.2	↑	6:	10.3x	↙	7:	9.2	↗	8:	10.3	↗	9:	5.5	↘	10:	9.1	↑	Series		90.0	Total		90.0	 <p>60 Prone</p>	<table border="1" style="width:100%; border-collapse: collapse;"> <tr><td>11:</td><td>9.7</td><td>→</td></tr> <tr><td>12:</td><td>9.8</td><td>↗</td></tr> <tr><td>13:</td><td>9.7</td><td>←</td></tr> <tr><td>14:</td><td>9.8</td><td>←</td></tr> <tr><td>15:</td><td>9.3</td><td>↗</td></tr> <tr><td>16:</td><td>10.1</td><td>↘</td></tr> <tr><td>17:</td><td>9.8</td><td>↑</td></tr> <tr><td>18:</td><td>8.9</td><td>↗</td></tr> <tr><td>19:</td><td>8.9</td><td>↗</td></tr> <tr><td>20:</td><td>9.4</td><td>↘</td></tr> <tr><td colspan="2">Series</td><td>89.0</td></tr> <tr><td colspan="2">Total</td><td>179.0</td></tr> </table>	11:	9.7	→	12:	9.8	↗	13:	9.7	←	14:	9.8	←	15:	9.3	↗	16:	10.1	↘	17:	9.8	↑	18:	8.9	↗	19:	8.9	↗	20:	9.4	↘	Series		89.0	Total		179.0
1:	10.6x	↙																																																																									
2:	9.4	↗																																																																									
3:	8.1	↗																																																																									
4:	10.1	↙																																																																									
5:	10.2	↑																																																																									
6:	10.3x	↙																																																																									
7:	9.2	↗																																																																									
8:	10.3	↗																																																																									
9:	5.5	↘																																																																									
10:	9.1	↑																																																																									
Series		90.0																																																																									
Total		90.0																																																																									
11:	9.7	→																																																																									
12:	9.8	↗																																																																									
13:	9.7	←																																																																									
14:	9.8	←																																																																									
15:	9.3	↗																																																																									
16:	10.1	↘																																																																									
17:	9.8	↑																																																																									
18:	8.9	↗																																																																									
19:	8.9	↗																																																																									
20:	9.4	↘																																																																									
Series		89.0																																																																									
Total		179.0																																																																									
 <p>60 Prone</p>	<table border="1" style="width:100%; border-collapse: collapse;"> <tr><td>21:</td><td>10.2</td><td>←</td></tr> <tr><td>22:</td><td>10.5x</td><td>↙</td></tr> <tr><td>23:</td><td>10.2</td><td>←</td></tr> <tr><td>24:</td><td>10.0</td><td>↓</td></tr> <tr><td>25:</td><td>10.3x</td><td>←</td></tr> <tr><td>26:</td><td>10.3</td><td>→</td></tr> <tr><td>27:</td><td>10.4x</td><td>↘</td></tr> <tr><td>28:</td><td>10.2</td><td>↓</td></tr> <tr><td>29:</td><td>9.8</td><td>←</td></tr> <tr><td>30:</td><td>9.3</td><td>↓</td></tr> <tr><td colspan="2">Series</td><td>98.0</td></tr> <tr><td colspan="2">Total</td><td>277.0</td></tr> </table>	21:	10.2	←	22:	10.5x	↙	23:	10.2	←	24:	10.0	↓	25:	10.3x	←	26:	10.3	→	27:	10.4x	↘	28:	10.2	↓	29:	9.8	←	30:	9.3	↓	Series		98.0	Total		277.0	 <p>60 Prone</p>	<table border="1" style="width:100%; border-collapse: collapse;"> <tr><td>31:</td><td>8.9</td><td>↗</td></tr> <tr><td>32:</td><td>8.7</td><td>←</td></tr> <tr><td>33:</td><td>10.2</td><td>↑</td></tr> <tr><td>34:</td><td>9.3</td><td>→</td></tr> <tr><td>35:</td><td>10.1</td><td>→</td></tr> <tr><td>36:</td><td>10.4x</td><td>↘</td></tr> <tr><td>37:</td><td>9.5</td><td>↑</td></tr> <tr><td>38:</td><td>9.0</td><td>↓</td></tr> <tr><td>39:</td><td>9.5</td><td>↘</td></tr> <tr><td>40:</td><td>10.1</td><td>↗</td></tr> <tr><td colspan="2">Series</td><td>92.0</td></tr> <tr><td colspan="2">Total</td><td>369.0</td></tr> </table>	31:	8.9	↗	32:	8.7	←	33:	10.2	↑	34:	9.3	→	35:	10.1	→	36:	10.4x	↘	37:	9.5	↑	38:	9.0	↓	39:	9.5	↘	40:	10.1	↗	Series		92.0	Total		369.0
21:	10.2	←																																																																									
22:	10.5x	↙																																																																									
23:	10.2	←																																																																									
24:	10.0	↓																																																																									
25:	10.3x	←																																																																									
26:	10.3	→																																																																									
27:	10.4x	↘																																																																									
28:	10.2	↓																																																																									
29:	9.8	←																																																																									
30:	9.3	↓																																																																									
Series		98.0																																																																									
Total		277.0																																																																									
31:	8.9	↗																																																																									
32:	8.7	←																																																																									
33:	10.2	↑																																																																									
34:	9.3	→																																																																									
35:	10.1	→																																																																									
36:	10.4x	↘																																																																									
37:	9.5	↑																																																																									
38:	9.0	↓																																																																									
39:	9.5	↘																																																																									
40:	10.1	↗																																																																									
Series		92.0																																																																									
Total		369.0																																																																									
 <p>60 Prone</p>	<table border="1" style="width:100%; border-collapse: collapse;"> <tr><td>41:</td><td>9.6</td><td>↗</td></tr> <tr><td>42:</td><td>9.3</td><td>↓</td></tr> <tr><td>43:</td><td>9.0</td><td>↓</td></tr> <tr><td>44:</td><td>9.3</td><td>→</td></tr> <tr><td>45:</td><td>8.5</td><td>↓</td></tr> <tr><td>46:</td><td>9.8</td><td>↓</td></tr> <tr><td>47:</td><td>9.6</td><td>←</td></tr> <tr><td>48:</td><td>10.4x</td><td>↗</td></tr> <tr><td>49:</td><td>10.1</td><td>↓</td></tr> <tr><td>50:</td><td>8.4</td><td>↖</td></tr> <tr><td colspan="2">Series</td><td>90.0</td></tr> <tr><td colspan="2">Total</td><td>459.0</td></tr> </table>	41:	9.6	↗	42:	9.3	↓	43:	9.0	↓	44:	9.3	→	45:	8.5	↓	46:	9.8	↓	47:	9.6	←	48:	10.4x	↗	49:	10.1	↓	50:	8.4	↖	Series		90.0	Total		459.0	 <p>60 Prone</p>	<table border="1" style="width:100%; border-collapse: collapse;"> <tr><td>51:</td><td>9.7</td><td>↘</td></tr> <tr><td>52:</td><td>10.5x</td><td>↘</td></tr> <tr><td>53:</td><td>9.8</td><td>→</td></tr> <tr><td>54:</td><td>9.9</td><td>↑</td></tr> <tr><td>55:</td><td>10.5x</td><td>↓</td></tr> <tr><td>56:</td><td>9.9</td><td>↗</td></tr> <tr><td>57:</td><td>9.2</td><td>↗</td></tr> <tr><td>58:</td><td>9.0</td><td>↗</td></tr> <tr><td>59:</td><td>9.1</td><td>↑</td></tr> <tr><td>60:</td><td>9.3</td><td>→</td></tr> <tr><td colspan="2">Series</td><td>92.0</td></tr> <tr><td colspan="2">Total</td><td>551.0</td></tr> </table>	51:	9.7	↘	52:	10.5x	↘	53:	9.8	→	54:	9.9	↑	55:	10.5x	↓	56:	9.9	↗	57:	9.2	↗	58:	9.0	↗	59:	9.1	↑	60:	9.3	→	Series		92.0	Total		551.0
41:	9.6	↗																																																																									
42:	9.3	↓																																																																									
43:	9.0	↓																																																																									
44:	9.3	→																																																																									
45:	8.5	↓																																																																									
46:	9.8	↓																																																																									
47:	9.6	←																																																																									
48:	10.4x	↗																																																																									
49:	10.1	↓																																																																									
50:	8.4	↖																																																																									
Series		90.0																																																																									
Total		459.0																																																																									
51:	9.7	↘																																																																									
52:	10.5x	↘																																																																									
53:	9.8	→																																																																									
54:	9.9	↑																																																																									
55:	10.5x	↓																																																																									
56:	9.9	↗																																																																									
57:	9.2	↗																																																																									
58:	9.0	↗																																																																									
59:	9.1	↑																																																																									
60:	9.3	→																																																																									
Series		92.0																																																																									
Total		551.0																																																																									

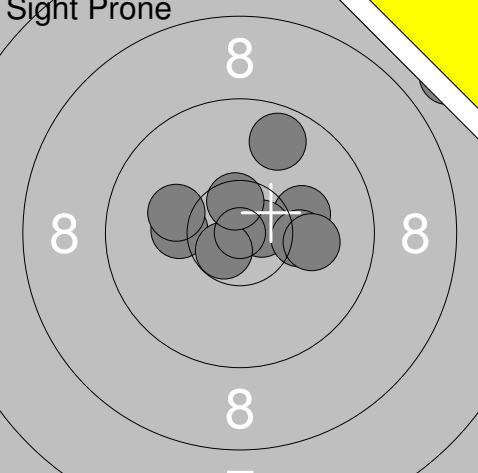
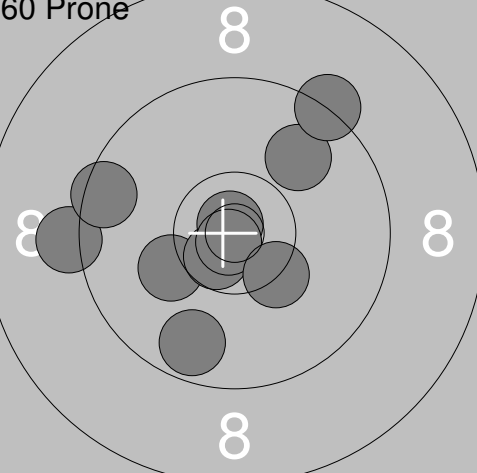
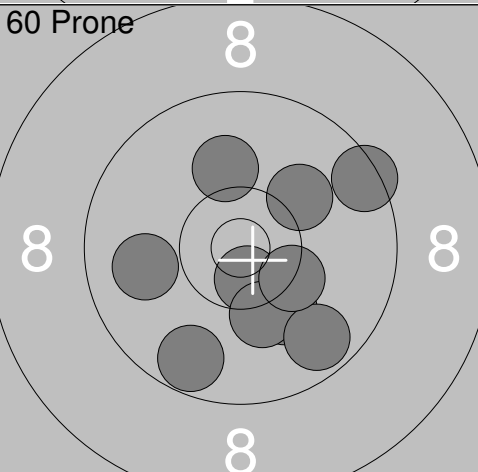
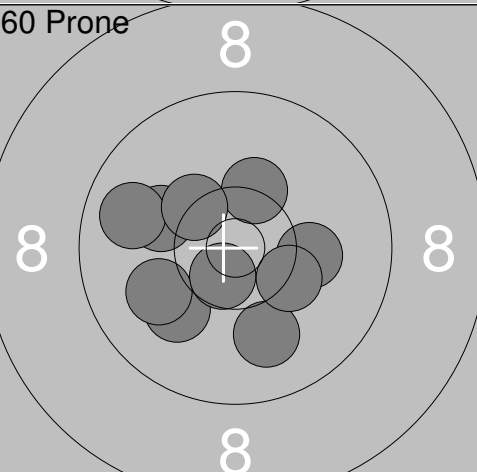
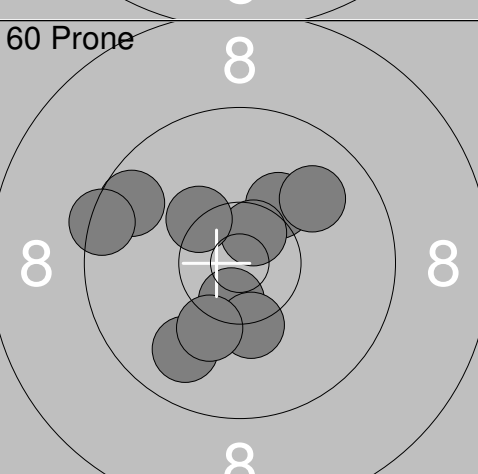
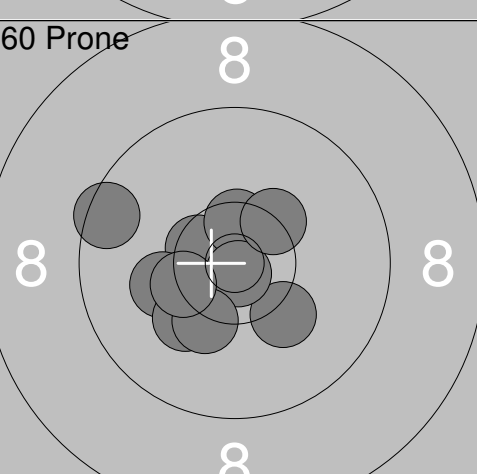
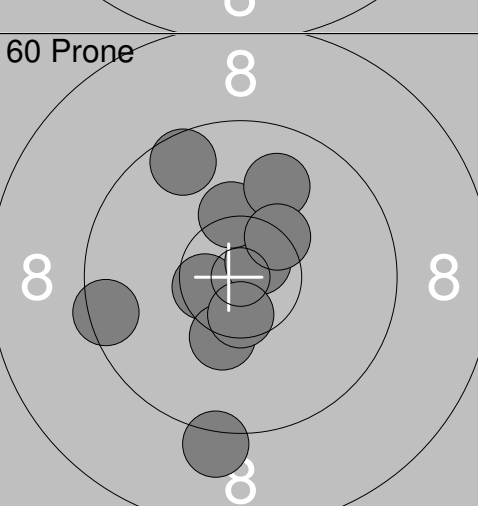
<p><b>Sight Prone</b></p> 	<p><b>60 Prone</b></p> 	<table border="1" style="width:100%; border-collapse: collapse;"> <tr><td>1: 7.8 ↗</td><td>1: 10.2 ←</td></tr> <tr><td>2: 10.2 →</td><td>2: 9.2 ←</td></tr> <tr><td>3: 10.2 ←</td><td>3: 10.6x ↘</td></tr> <tr><td>4: 9.7 ↑</td><td>4: 9.9 ↗</td></tr> <tr><td>5: 10.7x →</td><td>5: 10.8x ↗</td></tr> <tr><td>6: 10.1 ←</td><td>6: 10.8x ↘</td></tr> <tr><td>7: 10.2 →</td><td>7: 9.7 ↘</td></tr> <tr><td>8: 10.7x ↘</td><td>8: 9.5 ←</td></tr> <tr><td>9: 10.1 →</td><td>9: 9.3 ↗</td></tr> <tr><td>10: 10.6x ↑</td><td>10: 10.3x ↘</td></tr> <tr><td><b>Series</b> 96.0</td><td><b>Series</b> 95.0</td></tr> <tr><td><b>Total</b> 0.0</td><td><b>Total</b> 95.0</td></tr> </table>	1: 7.8 ↗	1: 10.2 ←	2: 10.2 →	2: 9.2 ←	3: 10.2 ←	3: 10.6x ↘	4: 9.7 ↑	4: 9.9 ↗	5: 10.7x →	5: 10.8x ↗	6: 10.1 ←	6: 10.8x ↘	7: 10.2 →	7: 9.7 ↘	8: 10.7x ↘	8: 9.5 ←	9: 10.1 →	9: 9.3 ↗	10: 10.6x ↑	10: 10.3x ↘	<b>Series</b> 96.0	<b>Series</b> 95.0	<b>Total</b> 0.0	<b>Total</b> 95.0
1: 7.8 ↗	1: 10.2 ←																									
2: 10.2 →	2: 9.2 ←																									
3: 10.2 ←	3: 10.6x ↘																									
4: 9.7 ↑	4: 9.9 ↗																									
5: 10.7x →	5: 10.8x ↗																									
6: 10.1 ←	6: 10.8x ↘																									
7: 10.2 →	7: 9.7 ↘																									
8: 10.7x ↘	8: 9.5 ←																									
9: 10.1 →	9: 9.3 ↗																									
10: 10.6x ↑	10: 10.3x ↘																									
<b>Series</b> 96.0	<b>Series</b> 95.0																									
<b>Total</b> 0.0	<b>Total</b> 95.0																									
<p><b>60 Prone</b></p> 	<p><b>60 Prone</b></p> 	<table border="1" style="width:100%; border-collapse: collapse;"> <tr><td>11: 10.1 ↘</td><td>21: 10.2 →</td></tr> <tr><td>12: 9.7 ↘</td><td>22: 10.1 ←</td></tr> <tr><td>13: 9.4 →</td><td>23: 10.3x ↑</td></tr> <tr><td>14: 10.6x ↘</td><td>24: 9.8 ←</td></tr> <tr><td>15: 10.2 ↘</td><td>25: 10.3x ↗</td></tr> <tr><td>16: 10.1 ↑</td><td>26: 10.1 ↘</td></tr> <tr><td>17: 9.9 ←</td><td>27: 10.0 ←</td></tr> <tr><td>18: 9.7 ↘</td><td>28: 10.6x ↘</td></tr> <tr><td>19: 10.3x ↘</td><td>29: 10.0 ↘</td></tr> <tr><td>20: 10.1 ↗</td><td>30: 10.3x ↘</td></tr> <tr><td><b>Series</b> 96.0</td><td><b>Series</b> 99.0</td></tr> <tr><td><b>Total</b> 191.0</td><td><b>Total</b> 290.0</td></tr> </table>	11: 10.1 ↘	21: 10.2 →	12: 9.7 ↘	22: 10.1 ←	13: 9.4 →	23: 10.3x ↑	14: 10.6x ↘	24: 9.8 ←	15: 10.2 ↘	25: 10.3x ↗	16: 10.1 ↑	26: 10.1 ↘	17: 9.9 ←	27: 10.0 ←	18: 9.7 ↘	28: 10.6x ↘	19: 10.3x ↘	29: 10.0 ↘	20: 10.1 ↗	30: 10.3x ↘	<b>Series</b> 96.0	<b>Series</b> 99.0	<b>Total</b> 191.0	<b>Total</b> 290.0
11: 10.1 ↘	21: 10.2 →																									
12: 9.7 ↘	22: 10.1 ←																									
13: 9.4 →	23: 10.3x ↑																									
14: 10.6x ↘	24: 9.8 ←																									
15: 10.2 ↘	25: 10.3x ↗																									
16: 10.1 ↑	26: 10.1 ↘																									
17: 9.9 ←	27: 10.0 ←																									
18: 9.7 ↘	28: 10.6x ↘																									
19: 10.3x ↘	29: 10.0 ↘																									
20: 10.1 ↗	30: 10.3x ↘																									
<b>Series</b> 96.0	<b>Series</b> 99.0																									
<b>Total</b> 191.0	<b>Total</b> 290.0																									
<p><b>60 Prone</b></p> 	<p><b>60 Prone</b></p> 	<table border="1" style="width:100%; border-collapse: collapse;"> <tr><td>31: 10.2 ↗</td><td>41: 10.2 ↘</td></tr> <tr><td>32: 9.9 ↘</td><td>42: 9.5 ←</td></tr> <tr><td>33: 9.6 ←</td><td>43: 10.5x ←</td></tr> <tr><td>34: 10.5x ↘</td><td>44: 10.5x ↑</td></tr> <tr><td>35: 10.6x ↑</td><td>45: 10.8x ↘</td></tr> <tr><td>36: 10.3 ↘</td><td>46: 10.2 ←</td></tr> <tr><td>37: 10.3x ↗</td><td>47: 10.3x ↗</td></tr> <tr><td>38: 9.9 ↗</td><td>48: 10.2 ↘</td></tr> <tr><td>39: 9.4 ←</td><td>49: 10.3 ↘</td></tr> <tr><td>40: 10.2 ↘</td><td>50: 10.4x ←</td></tr> <tr><td><b>Series</b> 96.0</td><td><b>Series</b> 99.0</td></tr> <tr><td><b>Total</b> 386.0</td><td><b>Total</b> 485.0</td></tr> </table>	31: 10.2 ↗	41: 10.2 ↘	32: 9.9 ↘	42: 9.5 ←	33: 9.6 ←	43: 10.5x ←	34: 10.5x ↘	44: 10.5x ↑	35: 10.6x ↑	45: 10.8x ↘	36: 10.3 ↘	46: 10.2 ←	37: 10.3x ↗	47: 10.3x ↗	38: 9.9 ↗	48: 10.2 ↘	39: 9.4 ←	49: 10.3 ↘	40: 10.2 ↘	50: 10.4x ←	<b>Series</b> 96.0	<b>Series</b> 99.0	<b>Total</b> 386.0	<b>Total</b> 485.0
31: 10.2 ↗	41: 10.2 ↘																									
32: 9.9 ↘	42: 9.5 ←																									
33: 9.6 ←	43: 10.5x ←																									
34: 10.5x ↘	44: 10.5x ↑																									
35: 10.6x ↑	45: 10.8x ↘																									
36: 10.3 ↘	46: 10.2 ←																									
37: 10.3x ↗	47: 10.3x ↗																									
38: 9.9 ↗	48: 10.2 ↘																									
39: 9.4 ←	49: 10.3 ↘																									
40: 10.2 ↘	50: 10.4x ←																									
<b>Series</b> 96.0	<b>Series</b> 99.0																									
<b>Total</b> 386.0	<b>Total</b> 485.0																									
<p><b>60 Prone</b></p> 	<table border="1" style="width:100%; border-collapse: collapse;"> <tr><td>51: 10.6x ←</td></tr> <tr><td>52: 9.2 ↘</td></tr> <tr><td>53: 10.7x ↗</td></tr> <tr><td>54: 10.3 ↘</td></tr> <tr><td>55: 10.3 ↑</td></tr> <tr><td>56: 9.5 ←</td></tr> <tr><td>57: 9.9 ↗</td></tr> <tr><td>58: 9.6 ↗</td></tr> <tr><td>59: 10.5x ↘</td></tr> <tr><td>60: 10.4x ↗</td></tr> <tr><td><b>Series</b> 96.0</td></tr> <tr><td><b>Total</b> 581.0</td></tr> </table>	51: 10.6x ←	52: 9.2 ↘	53: 10.7x ↗	54: 10.3 ↘	55: 10.3 ↑	56: 9.5 ←	57: 9.9 ↗	58: 9.6 ↗	59: 10.5x ↘	60: 10.4x ↗	<b>Series</b> 96.0	<b>Total</b> 581.0													
51: 10.6x ←																										
52: 9.2 ↘																										
53: 10.7x ↗																										
54: 10.3 ↘																										
55: 10.3 ↑																										
56: 9.5 ←																										
57: 9.9 ↗																										
58: 9.6 ↗																										
59: 10.5x ↘																										
60: 10.4x ↗																										
<b>Series</b> 96.0																										
<b>Total</b> 581.0																										

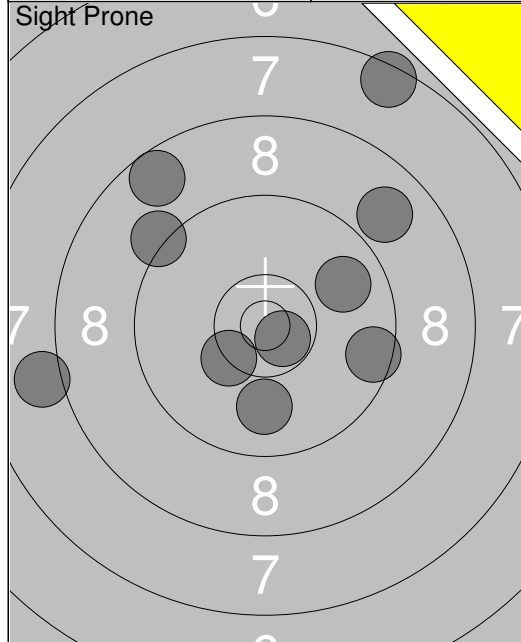

1:	8.6	↖
2:	7.5	↗
3:	8.9	↗
4:	10.7x	↘
5:	9.5	→
6:	10.3x	↙
7:	9.9	↓
8:	8.1	←
9:	9.2	↖
10:	9.8	↗
Series	87.0	
Total	0.0	

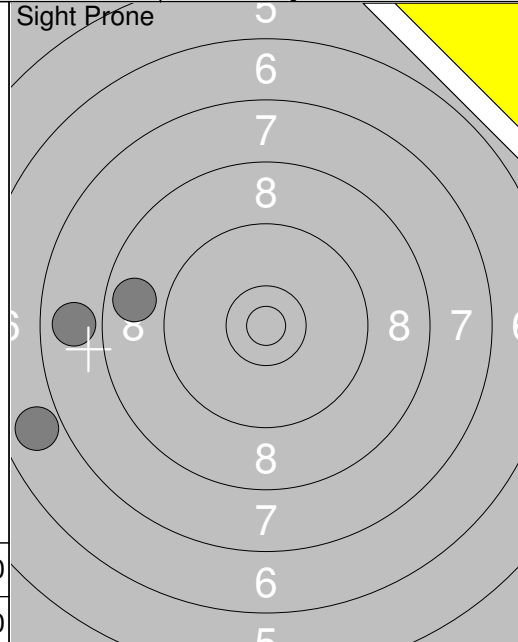

11:	7.8	←
12:	6.9	←
13:	8.8	←
Series	21.0	
Total	0.0	

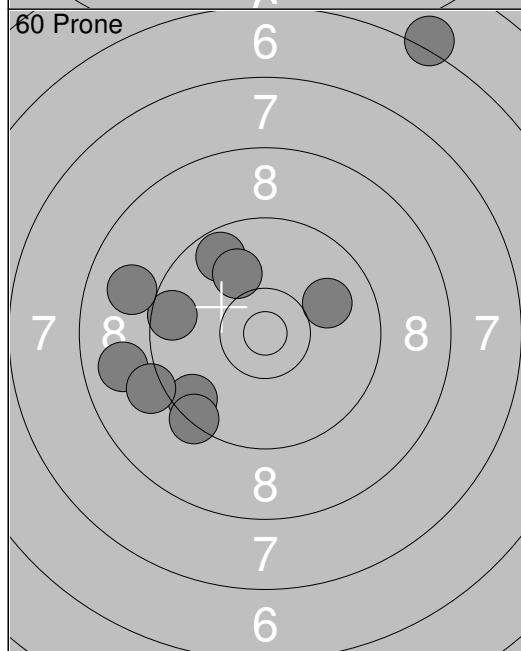

1:	8.9	←
2:	9.6	↙
3:	9.4	↙
4:	10.0	→
5:	9.7	↗
6:	9.1	←
7:	9.6	←
8:	6.2	↗
9:	9.0	←
10:	10.0	↗
Series	88.0	
Total	88.0	

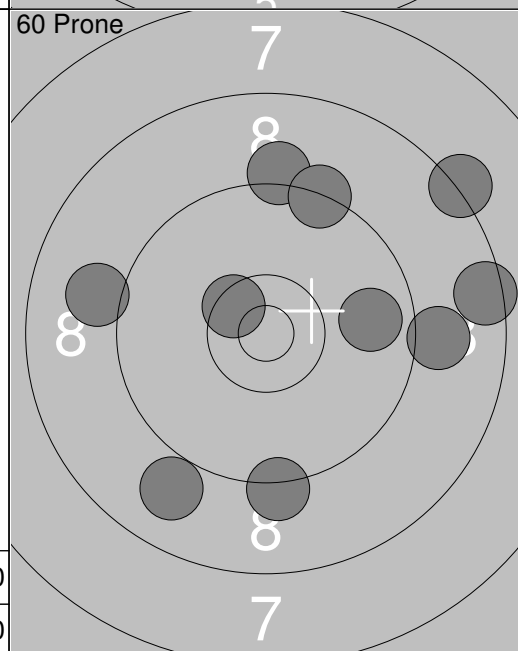

11:	8.3	↗
12:	9.2	↑
13:	9.8	→
14:	9.0	←
15:	9.3	↗
16:	10.5x	↙
17:	9.2	↓
18:	8.5	→
19:	9.0	→
20:	8.9	↙
Series	88.0	
Total	176.0	

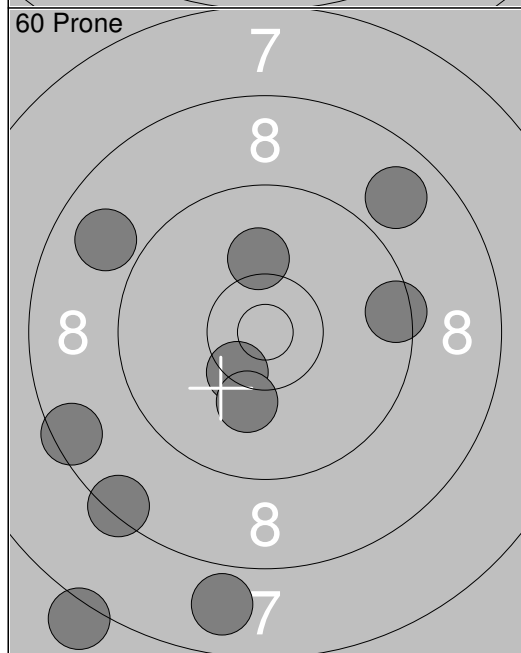

21:	8.9	↗
22:	10.4x	↙
23:	10.1	↑
24:	10.1	↓
25:	9.5	→
26:	7.9	↓
27:	8.5	←
28:	8.9	↖
29:	7.1	↙
30:	8.4	↙
Series	85.0	
Total	261.0	

<p>Sight Prone</p>	<p>Sight Prone</p>
1: 8.8 ↘ 2: 9.9 ↗ 3: 9.1 ↘ 4: 10.1 → 5: 10.8x ↗ 6: 9.8 → 7: 10.9x ↙ 8: 10.4x ↘ 9: 10.3x ↗ 10: 9.5 → Series 94.0 Total 0.0	11: 10.8x → 12: 10.0 ↗ 13: 10.4x ↘ 14: 10.0 ↘ 15: 10.2 ↘ 16: 10.6x ↙ Series 60.0 Total 0.0

<p>60 Prone</p>	<p>60 Prone</p>
1: 10.3 ← 2: 10.6x ↘ 3: 10.1 ← 4: 10.7x ← 5: 10.4x ↗ 6: 9.4 → 7: 10.7x ↗ 8: 10.1 ↗ 9: 10.5x → 10: 10.2 ← Series 99.0 Total 99.0	11: 10.0 ↗ 12: 10.7x ← 13: 10.3x ← 14: 10.4x ↗ 15: 10.4x ↗ 16: 9.6 → 17: 10.4x ↙ 18: 10.1 ↘ 19: 10.1 ↗ 20: 10.8x ↗ Series 99.0 Total 198.0

<p>60 Prone</p>	
21: 10.4x ↘ 22: 10.6x ↙ 23: 10.4x → 24: 10.2 ↗ 25: 10.1 ↗ 26: 10.0 ↗ 27: 10.7x ↗ 28: 9.8 → 29: 10.5x → 30: 9.6 ↗ Series 98.0 Total 296.0	

<p>Sight Prone</p>	<p>1: 8.8 ← 2: 7.5 ← 3: 7.8 ↙ 4: 9.0 ← 5: 9.5 ← 6: 9.6 ↑ 7: 9.3 ← 8: 10.4x ← 9: 9.2 ← 10: 9.2 →</p> <p>Series 86.0 Total 0.0</p>	<p>Sight Prone</p>	<p>11: 7.1 → 12: 8.6 ↖</p> <p>Series 15.0 Total 0.0</p>
<p>60 Prone</p>	<p>1: 9.3 → 2: 7.5 ↓ 3: 8.5 ↓ 4: 9.0 ↙ 5: 9.3 → 6: 8.2 ← 7: 8.9 ↙ 8: 10.4x ← 9: 10.3x → 10: 9.4 ←</p> <p>Series 87.0 Total 87.0</p>	<p>60 Prone</p>	<p>11: 10.1 ↘ 12: 10.1 → 13: 9.9 ↑ 14: 9.6 ← 15: 8.3 ← 16: 9.9 ← 17: 9.0 → 18: 9.7 ↑ 19: 9.1 ↓ 20: 9.6 ↓</p> <p>Series 91.0 Total 178.0</p>
<p>60 Prone</p>	<p>21: 9.2 ← 22: 9.3 ↓ 23: 10.2 ↓ 24: 6.9 ← 25: 8.2 ↗ 26: 9.6 ← 27: 8.7 ↗ 28: 9.5 ↑ 29: 9.2 → 30: 10.1 →</p> <p>Series 87.0 Total 265.0</p>	<p>60 Prone</p>	<p>31: 10.3 ← 32: 10.1 ↗ 33: 10.4x ↓ 34: 9.1 → 35: 10.3x ← 36: 9.2 ↑ 37: 10.5x ↗ 38: 9.0 ↗ 39: 9.6 ← 40: 10.2 →</p> <p>Series 96.0 Total 361.0</p>
<p>60 Prone</p>	<p>41: 9.9 ↑ 42: 9.0 → 43: 9.7 ↑ 44: 9.3 → 45: 9.3 ↘ 46: 10.0 ← 47: 10.3x → 48: 7.3 ↙ 49: 7.7 ↘ 50: 9.0 →</p> <p>Series 88.0 Total 449.0</p>	<p>60 Prone</p>	<p>51: 7.5 ↘ 52: 8.8 → 53: 10.6x ↘ 54: 9.7 ↖ 55: 10.7x ↑ 56: 9.5 ↓ 57: 8.9 ↖ 58: 9.9 ← 59: 9.0 ↑ 60: 0.0</p> <p>Series 79.0 Total 528.0</p>