

1:	9.5 ↖
2:	10.2 ↑
3:	*10.6 →
4:	8.0 →
5:	9.9 ←
Series 46.0	
Total 0.0	

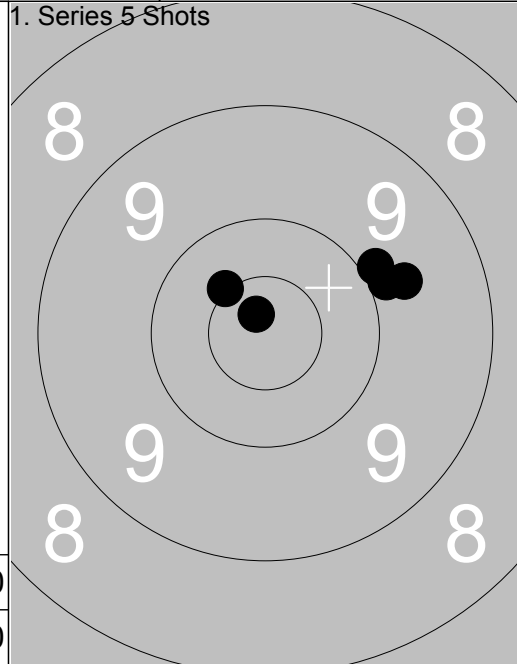

1:	9.9 →
2:	*10.5 ↖
3:	*10.8 ↖
4:	9.9 →
5:	9.7 →
Series 47.0	
Total 47.0	

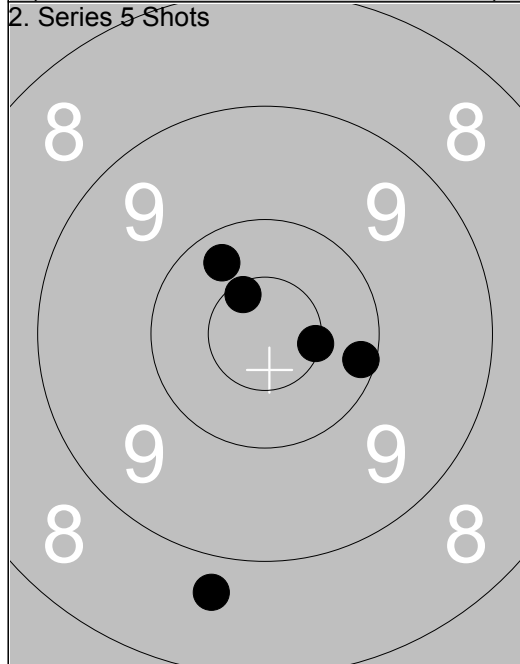

1:	10.1 →
2:	*10.5 →
3:	8.7 ↓
4:	*10.6 ↖
5:	10.3 ↗
Series 48.0	
Total 95.0	

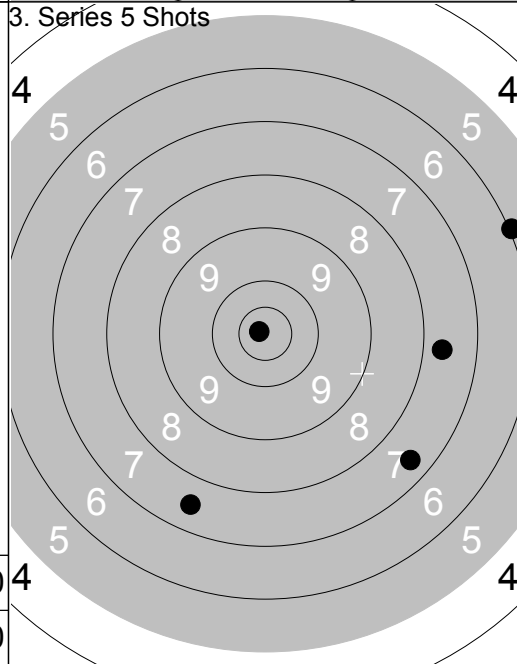

1:	6.0 →
2:	7.5 ↓
3:	*10.8 ↖
4:	7.4 ↓
5:	7.7 →
Series 37.0	
Total 132.0	

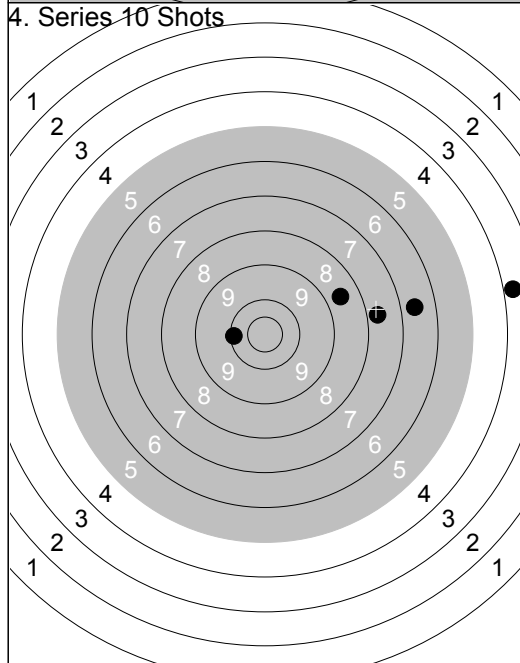

1:	3.8 →
2:	7.7 →
3:	6.6 →
4:	10.1 ←
5:	8.6 →
Series 34.0	
Total 166.0	

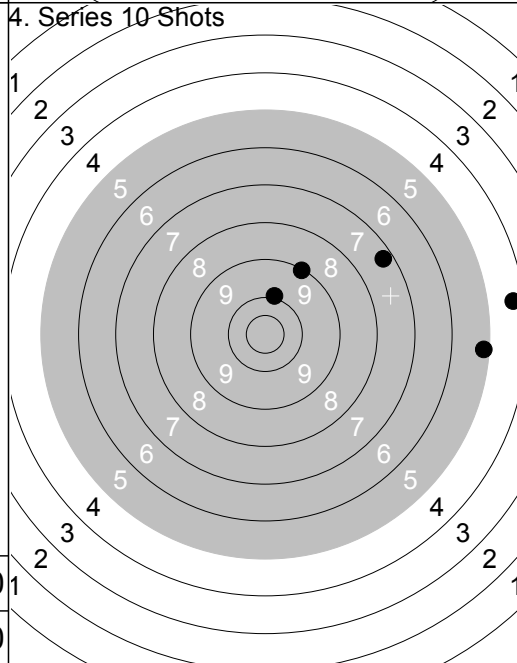

6:	5.2 →
7:	7.3 →
8:	4.4 →
9:	9.1 ↗
10:	10.0 ↗
Series 35.0	
Total 201.0	

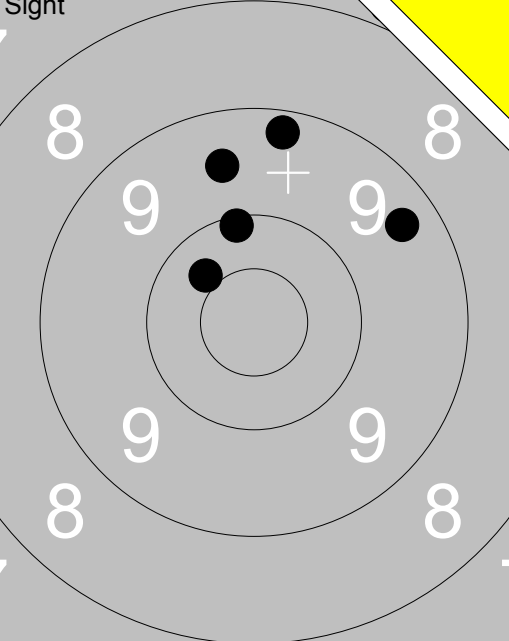
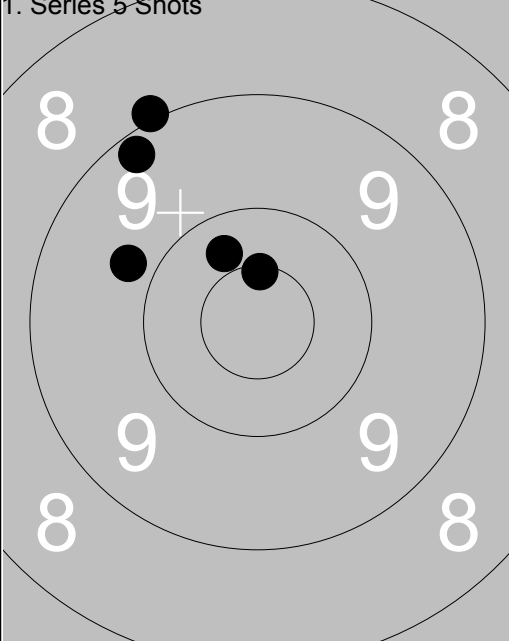
<p>Sight</p> 	<p>1: 7.8 ↗ 2: 9.4 ↗ 3: 10.1 ↑ 4: 9.2 ↑ 5: 10.4 ↖ 6: 9.5 ↑</p>	<p>1. Series 5 Shots</p> 		<p>1: 9.0 ↖ 2: 9.8 ↖ 3: 10.3 ↖ 4: 9.2 ↖ 5: *10.5 ↑</p>
Series 54.0		Series 47.0		
Total 0.0		Total 47.0		

<p>2. Series 5 Shots</p> 	<p>1: 9.1 ↑ 2: 8.2 ↓ 3: 9.1 ↓ 4: 9.6 ↙ 5: 6.6 ↓</p>	<p>3. Series 5 Shots</p> 		<p>1: 9.5 ↖ 2: 7.7 ↘ 3: 8.7 ↓ 4: 5.6 → 5: 6.3 ↖</p>
Series 41.03		Series 35.0		
Total 88.0		Total 123.0		

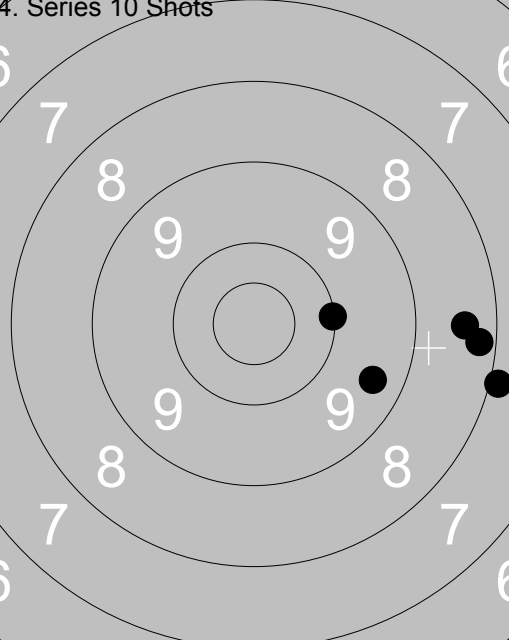
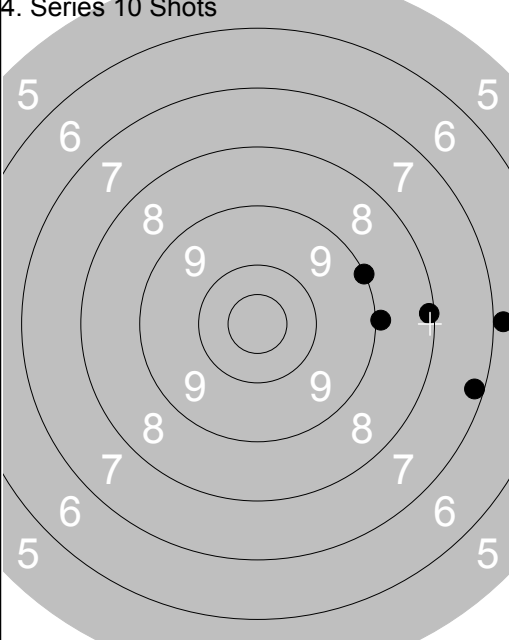
<p>4. Series 10 Shots</p> 	<p>1: 10.1 → 2: 8.2 → 3: 8.4 → 4: 7.9 → 5: 9.4 →</p>	<p>4. Series 10 Shots</p> 		<p>6: 9.0 ↗ 7: 8.1 → 8: 6.9 → 9: 8.9 → 10: 7.2 →</p>
Series 42.0		Series 38.0		
Total 165.0		Total 203.0		

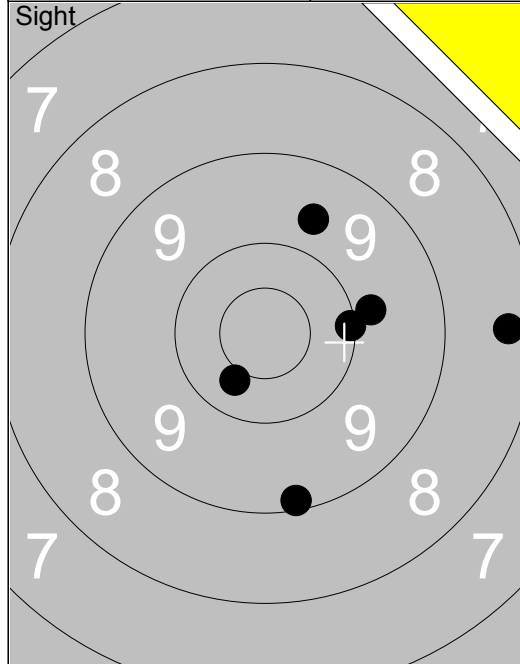

1:	9.8	→
2:	8.3	→
3:	10.1	→
4:	9.1	↓
5:	9.7	↑
6:	10.4	↘
Series		55.0
Total		0.0

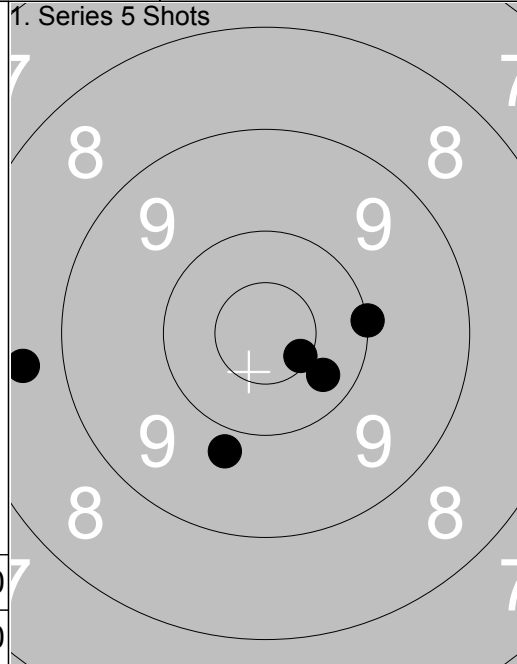

1:	*10.6	↘
2:	10.0	→
3:	8.6	←
4:	9.8	↓
5:	10.3	↘
Series		47.0
Total		47.0

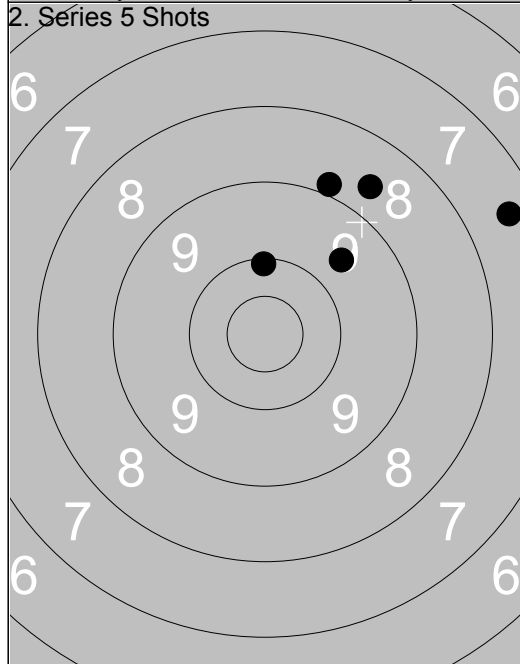

1:	8.6	↗
2:	7.4	→
3:	9.6	↗
4:	8.9	↑
5:	10.1	↑
Series		42.0
Total		89.0

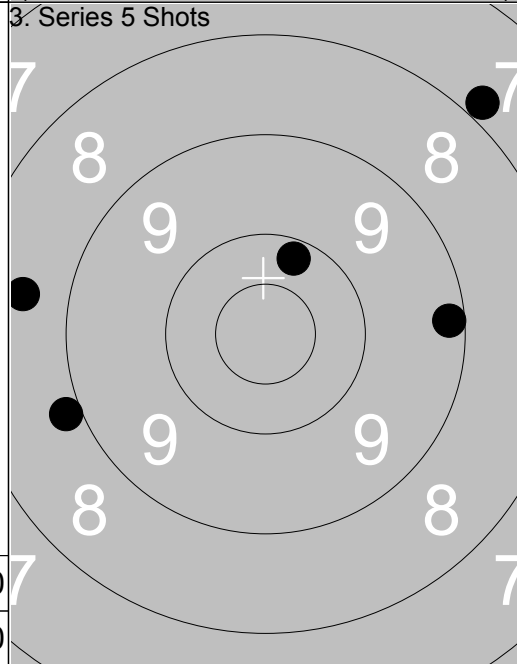

1:	9.2	→
2:	10.2	↑
3:	7.8	↗
4:	8.9	←
5:	8.6	←
Series		42.0
Total		131.0

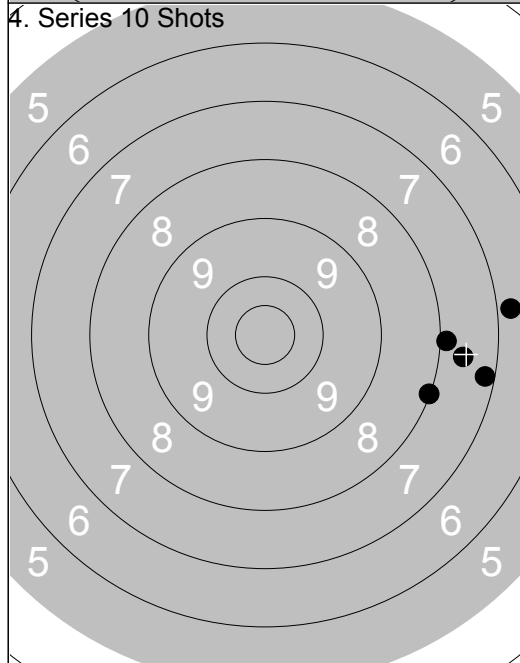

1:	8.0	→
2:	7.2	→
3:	7.9	→
4:	7.6	→
5:	6.8	→
Series		35.0
Total		166.0

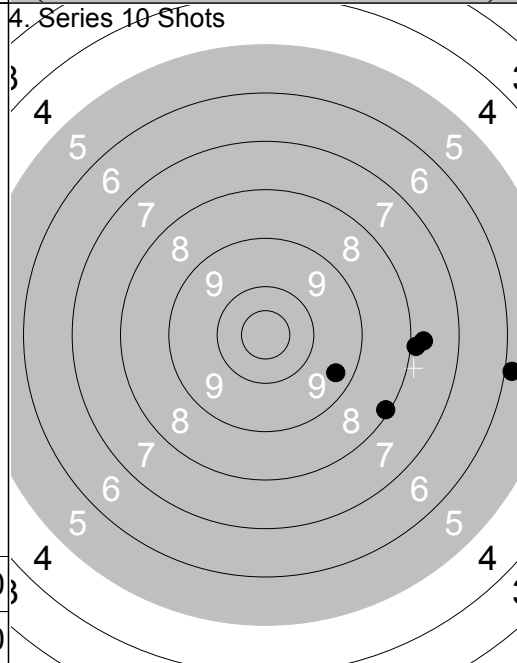

6:	8.1	↘
7:	7.8	→
8:	7.9	→
9:	5.9	→
10:	9.4	↘
Series		36.0
Total		202.0

Relay	Lane	Marlene Forsell	
300m		Ramselefors	B Vb
07.07.2014		Tavelträffen B 2014	Ramselefors SKF
Sight		1: 9.0 ↑ 2: 9.0 → 3: 9.6 → 4: *10.7 ↑ 5: 8.3 ↖ 6: 8.1 ↑	1: *10.5 ↗ 2: 9.9 ← 3: 9.8 ↘ 4: 9.6 ↑ 5: 9.5 ↓
		Series 53.0	Series 46.0
		Total 0.0	Total 46.0
2. Series 5 Shots		1: 8.3 ← 2: 10.2 → 3: 10.0 ↗ 4: 10.0 ↘ 5: 9.7 ↓	1: 8.6 ↗ 2: 10.3 → 3: 9.3 ↖ 4: 7.2 ← 5: 6.7 ↖
		Series 47.0	Series 40.0
		Total 93.0	Total 133.0
4. Series 10 Shots		1: 9.0 ↘ 2: 7.4 → 3: 7.5 → 4: 6.5 → 5: 7.6 →	6: 6.1 → 7: 7.1 ↗ 8: 7.6 ↘ 9: 8.1 ↘ 10: 6.5 →
		Series 36.0	Series 34.0
		Total 169.0	Total 203.0

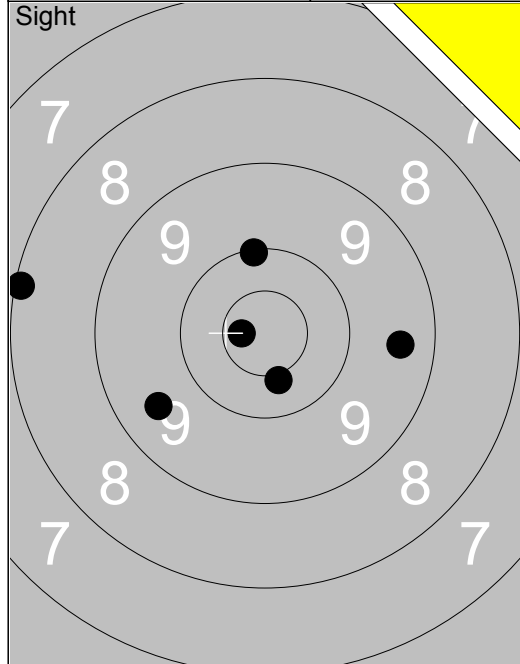

1:	9.5 ↙
2:	*10.7 ↖
3:	*10.4 ↓
4:	10.1 ↑
5:	8.1 ←
6:	9.4 →
<b>Series 56.0</b>	
<b>Total 0.0</b>	

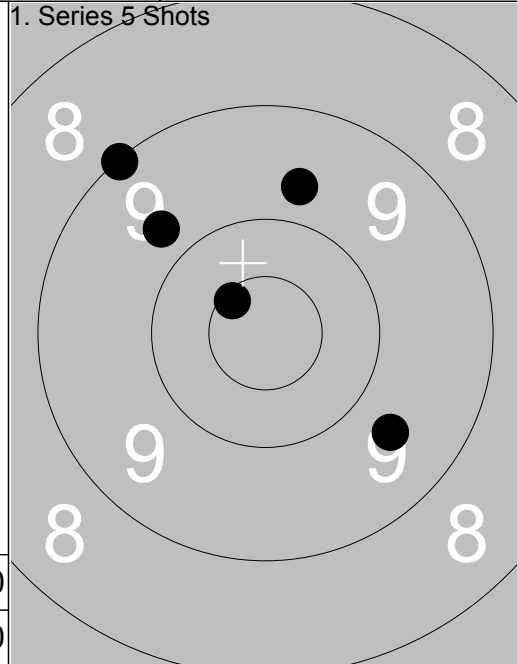

1:	9.1 ↗
2:	9.7 ↖
3:	9.7 ↑
4:	*10.6 ↖
5:	9.6 ↘
<b>Series 46.0</b>	
<b>Total 46.0</b>	

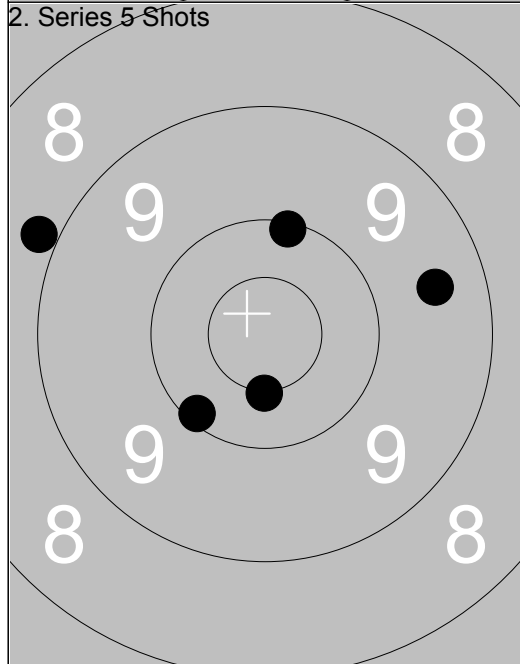

1:	8.9 ↖
2:	*10.5 ↓
3:	9.5 →
4:	10.1 ↑
5:	10.1 ↙
<b>Series 47.0</b>	
<b>Total 93.0</b>	



1:	8.1 →
2:	10.2 ↖
3:	9.9 ↑
4:	10.3 ↖
5:	10.1 ↙
<b>Series 47.0</b>	
<b>Total 140.0</b>	

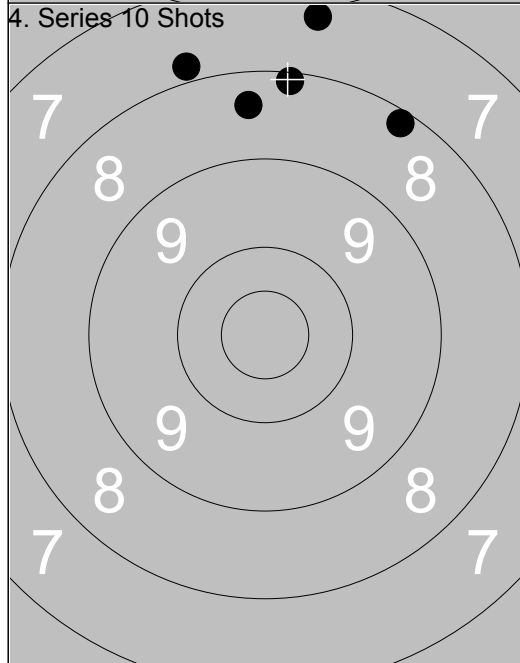

1:	8.4 ↑
2:	8.2 ↗
3:	7.9 ↑
4:	7.4 ↑
5:	8.1 ↑
<b>Series 38.02</b>	
<b>Total 178.0</b>	

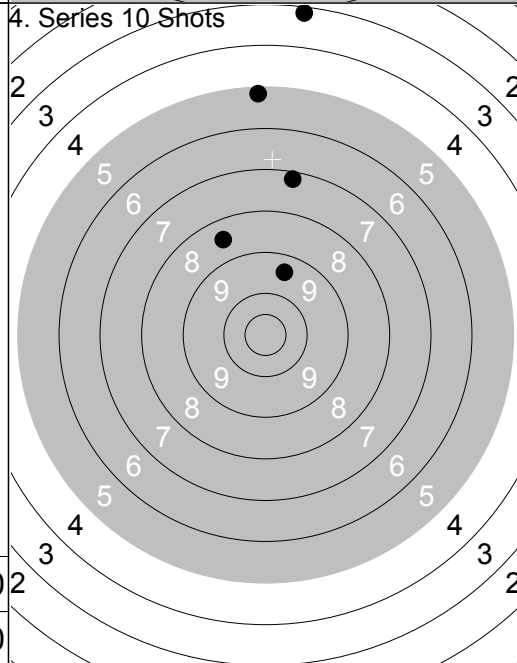

6:	5.2 ↑
7:	9.5 ↑
8:	8.5 ↖
9:	3.2 ↑
10:	7.2 ↑
<b>Series 32.0</b>	
<b>Total 210.0</b>	

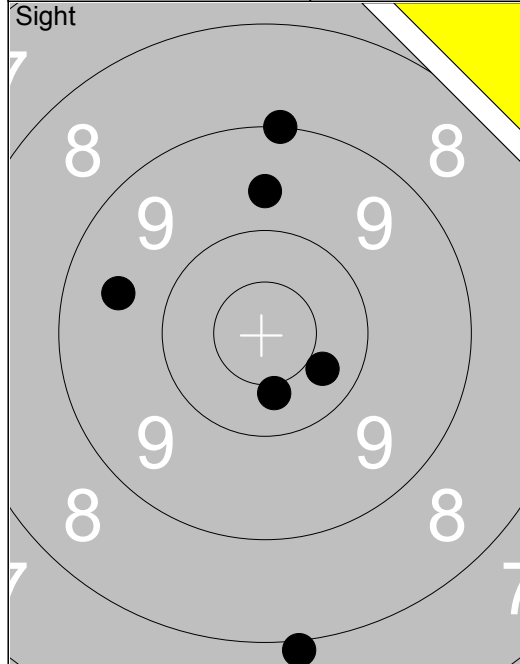

1:	9.7	↑
2:	9.0	↑
3:	10.4	↓
4:	10.3	↘
5:	7.9	↓
6:	9.6	←
Series		54.0
Total		0.0

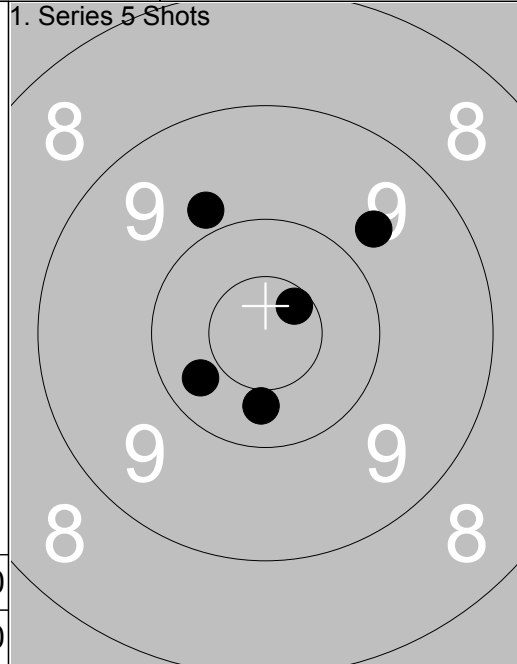

1:	10.4	↓
2:	9.8	↖
3:	9.7	↗
4:	10.3	↙
5:	*10.6	↗
Series		48.0
Total		48.0

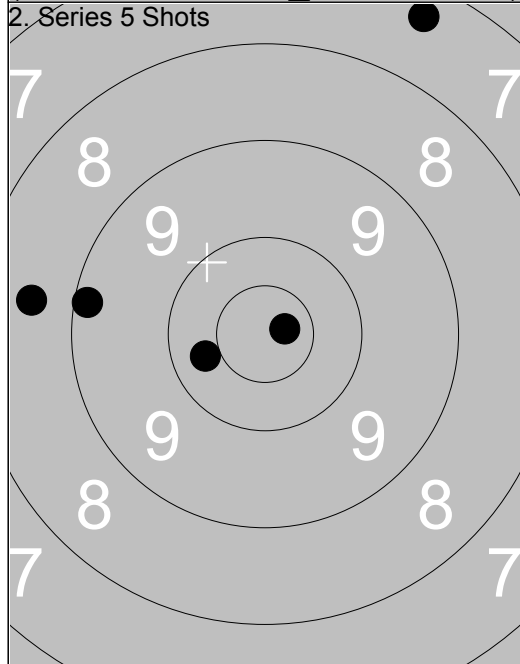

1:	10.3	↙
2:	9.2	←
3:	8.6	←
4:	*10.8	→
5:	7.4	↑
Series		44.0
Total		92.0

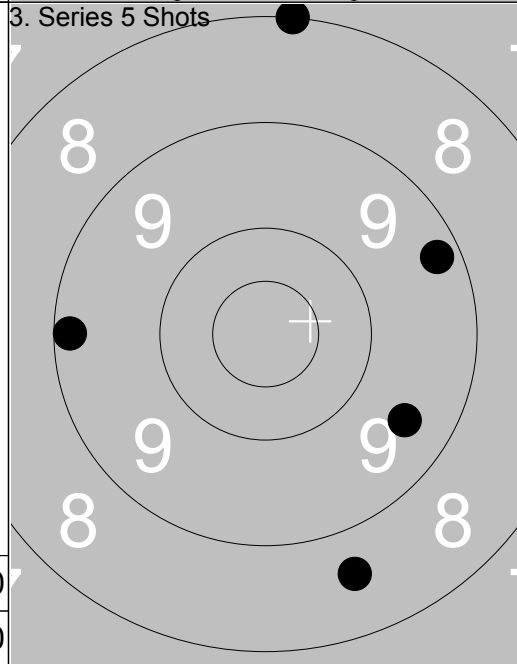

1:	8.6	↓
2:	8.0	↑
3:	9.2	←
4:	9.3	↗
5:	9.5	↘
Series		43.0
Total		135.0

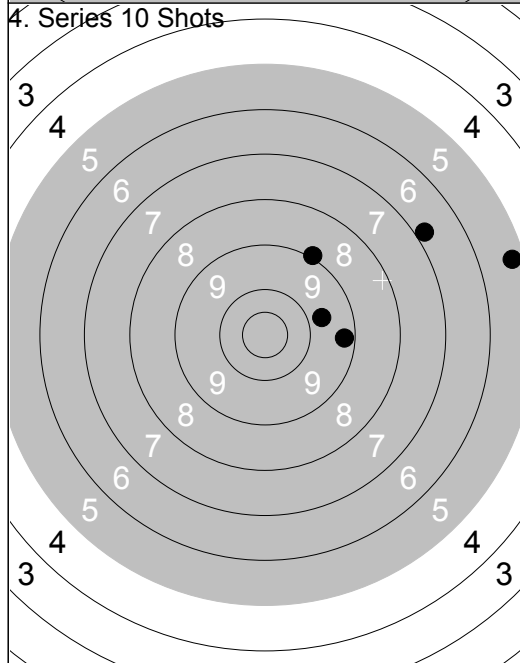

1:	5.3	→
2:	6.8	↗
3:	9.3	→
4:	9.0	↗
5:	9.7	→
Series		38.0
Total		173.0

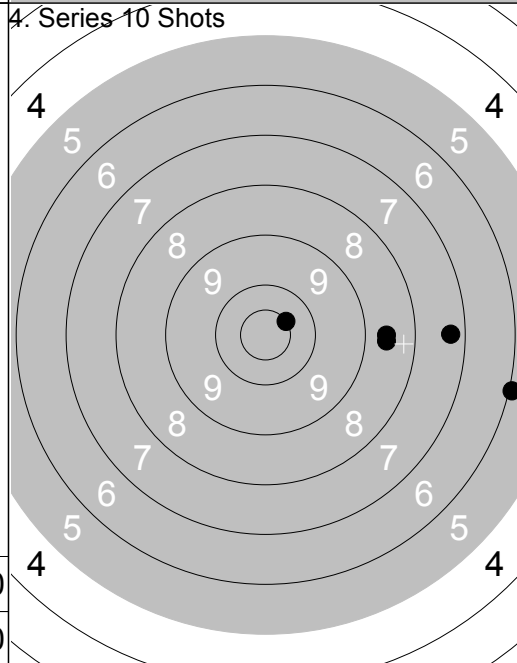

6:	6.0	→
7:	8.6	→
8:	7.3	→
9:	*10.5	↗
10:	8.6	→
Series		39.0
Total		212.0

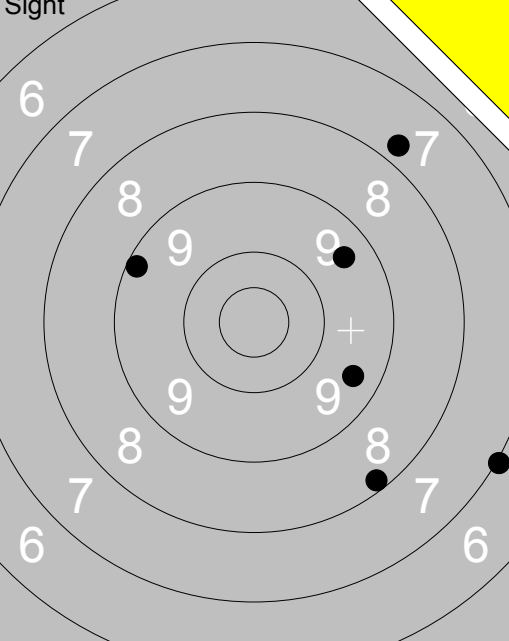
 <p>Sight</p>	<p>1: 7.8 ↗</p> <p>2: 9.4 ↗</p> <p>3: 9.4 ↘</p> <p>4: 9.2 ↖</p> <p>5: 7.0 ↘</p> <p>6: 8.2 ↘</p>	<p>1. Series 5 Shots</p>  <p>1: *10.6 ↖</p> <p>2: 8.4 ↑</p> <p>3: 9.7 ↖</p> <p>4: 9.9 ↑</p> <p>5: 9.2 ↗</p>
Series 49.0	Series 45.0	Series 45.0
Total 0.0	Total 45.0	Total 45.0

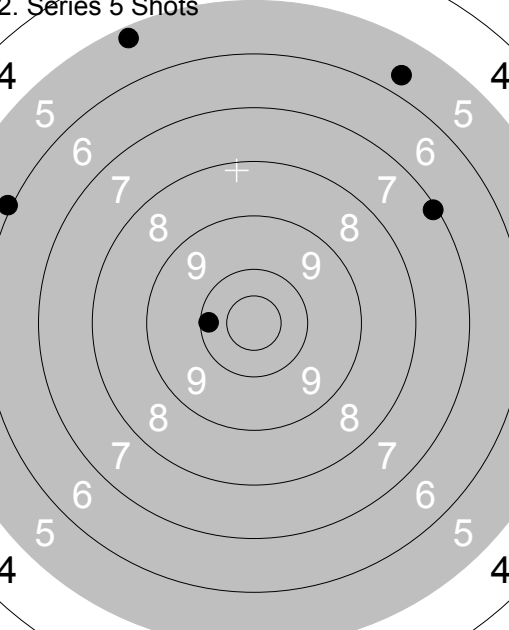
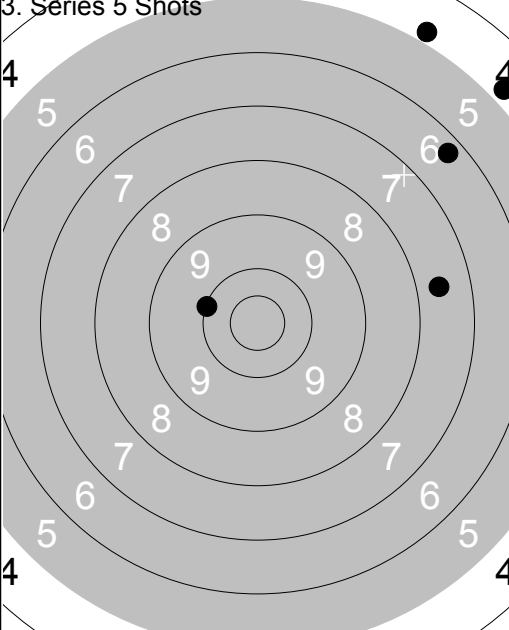
<p>2. Series 5 Shots</p> 	<p>1: 5.7 ↗</p> <p>2: 5.2 ↖</p> <p>3: 10.2 ←</p> <p>4: 7.1 ↗</p> <p>5: 6.0 ↖</p>	<p>3. Series 5 Shots</p>  <p>1: 4.8 ↗</p> <p>2: 6.3 ↗</p> <p>3: 7.6 →</p> <p>4: 4.8 ↗</p> <p>5: 10.0 ←</p>
Series 33.04	Series 31.04	Series 31.0
Total 78.0	Total 109.0	Total 109.0

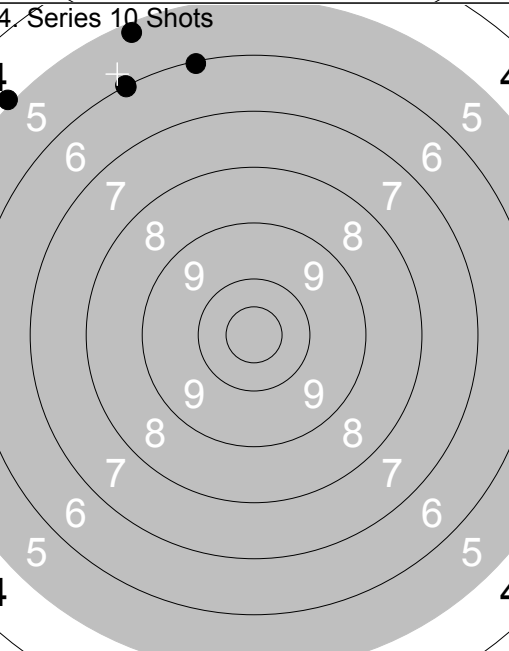
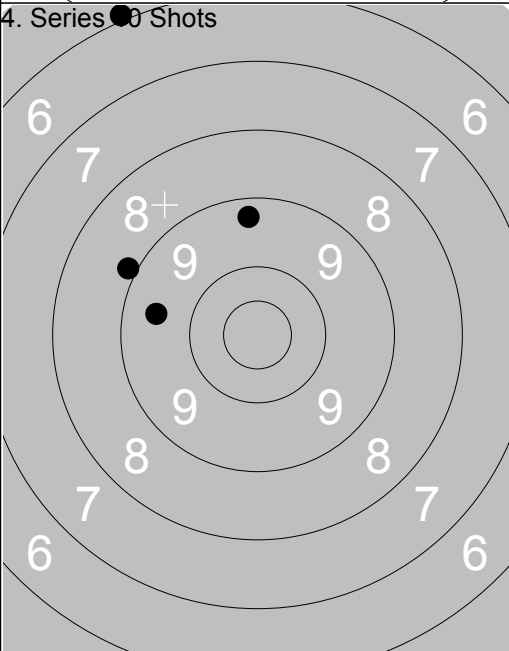
<p>4. Series 10 Shots</p> 	<p>1: 5.0 ↖</p> <p>2: 6.1 ↗</p> <p>3: 6.0 ↗</p> <p>4: 5.2 ↗</p> <p>5: 6.1 ↗</p>	<p>4. Series 10 Shots</p>  <p>6: 5.9 ↖</p> <p>7: 8.9 ↖</p> <p>8: 9.3 ↑</p> <p>9: 9.5 ←</p>
Series 28.0	Series 31.0	Series 31.0
Total 137.0	Total 168.0	Total 168.0

Relay **1** Lane **9** **Linda Bergman**

300m Ununge B St

07.07.2014 Tavelträffen B 2014 Ramselefors SKF

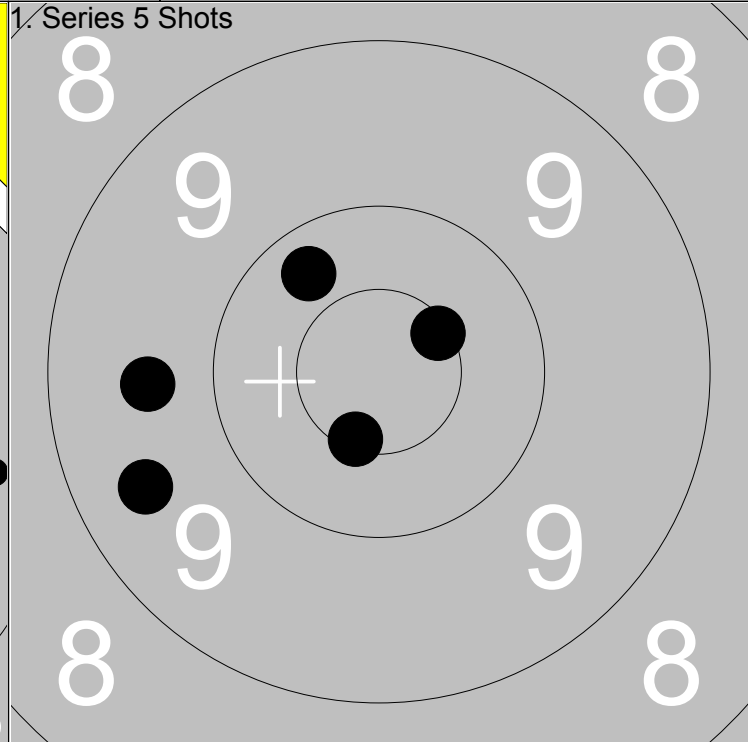
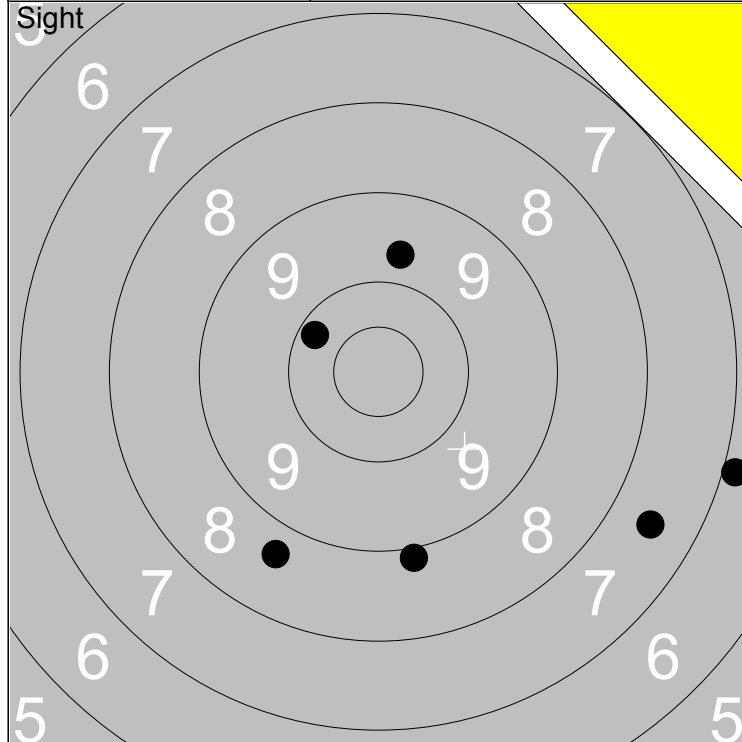

1: 8.7 ↘	6: 6.9 ➔	Series 48.0
2: 8.9 ↓		
3: 10.2 ↙		Total 0.0
4: 9.7 ↑		
5: 7.5 ➔		

1: 9.6 ←	Series 48.0
2: 9.5 ↙	
3: 10.3 ↖	Total 48.0
4: *10.6 ↗	
5: *10.6 ↓	

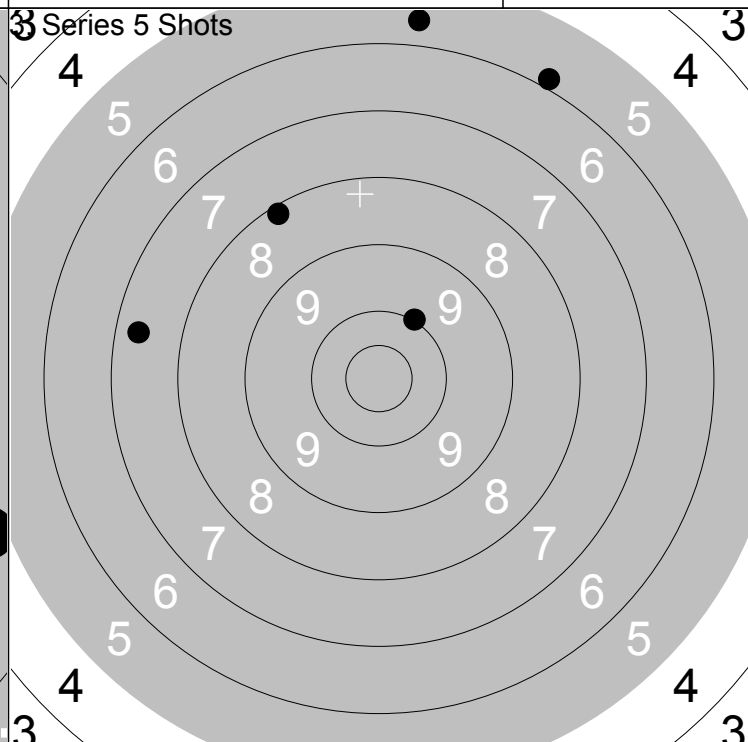
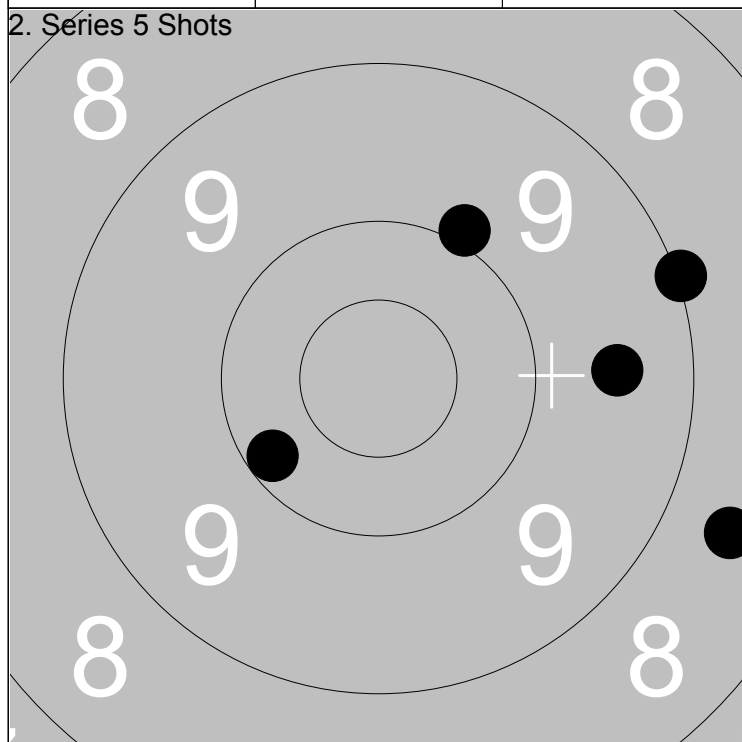

1: 8.6 ➔	Series 45.0
2: 9.5 ➔	
3: 9.0 ➔	Total 93.0
4: 10.2 ↙	
5: 9.9 ↗	

1: 7.4 ←	Series 35.0
2: 10.0 ↗	
3: 5.6 ↑	Total 128.0
4: 5.9 ↗	
5: 8.1 ↖	



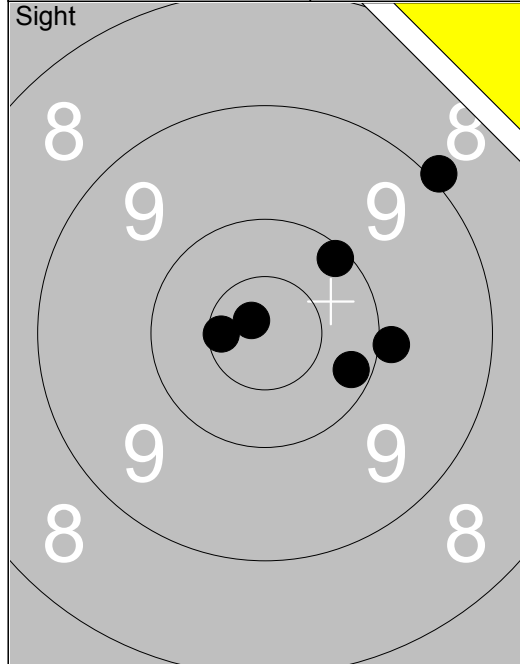

Series	58.0
Total	0.0

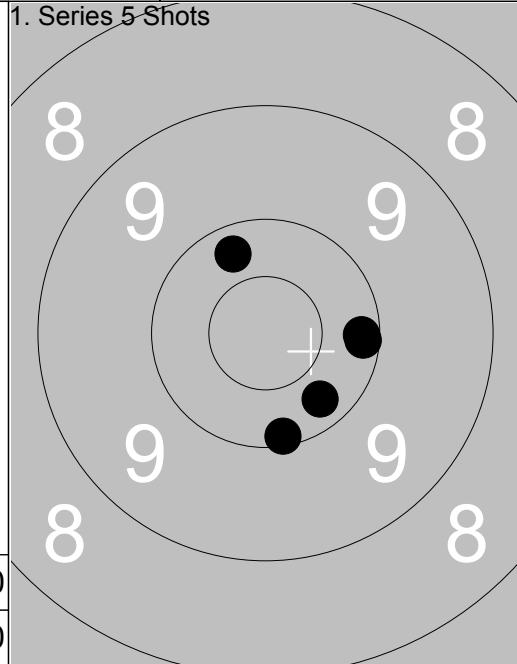

Series	50.0
Total	50.0

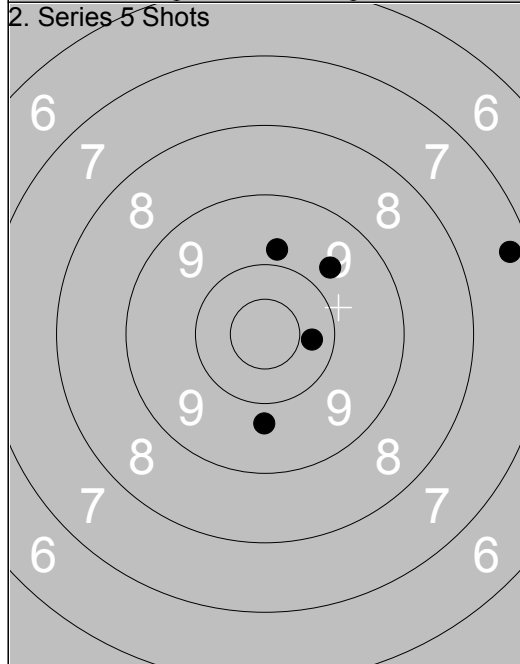

Series	44.0
Total	94.0

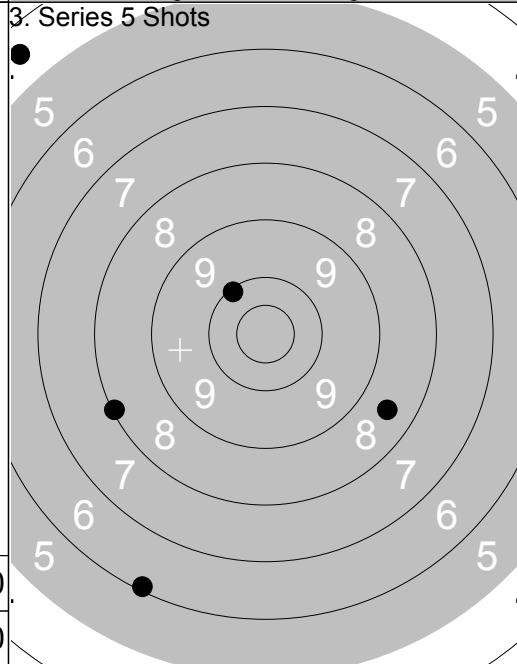

Series	36.0
Total	130.0

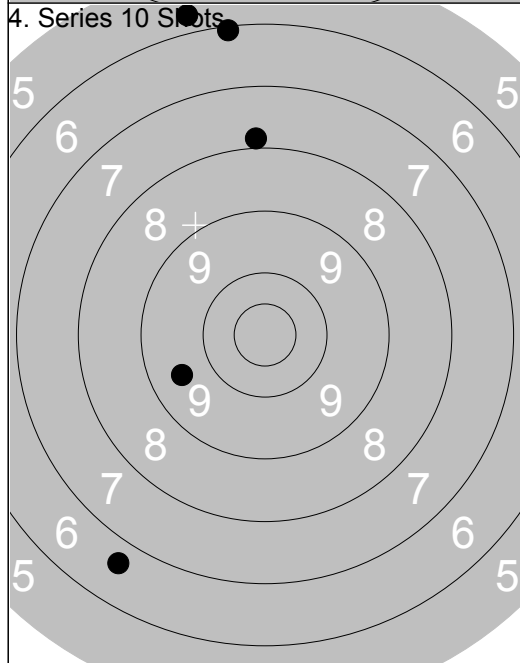

Series	33.0
Total	163.0

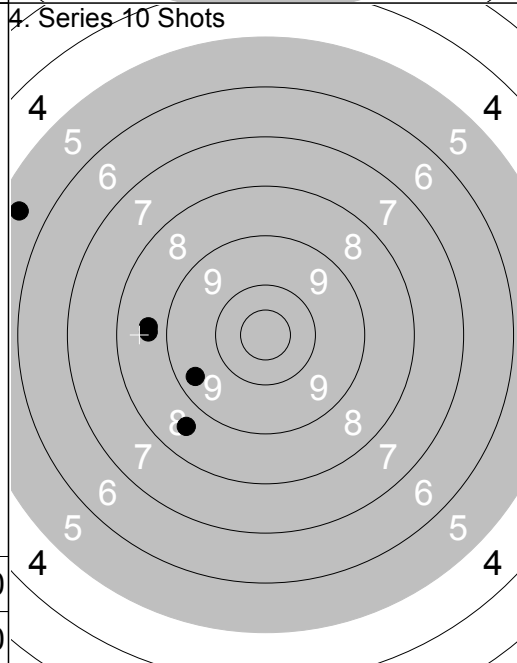

Series	38.0
Total	201.0

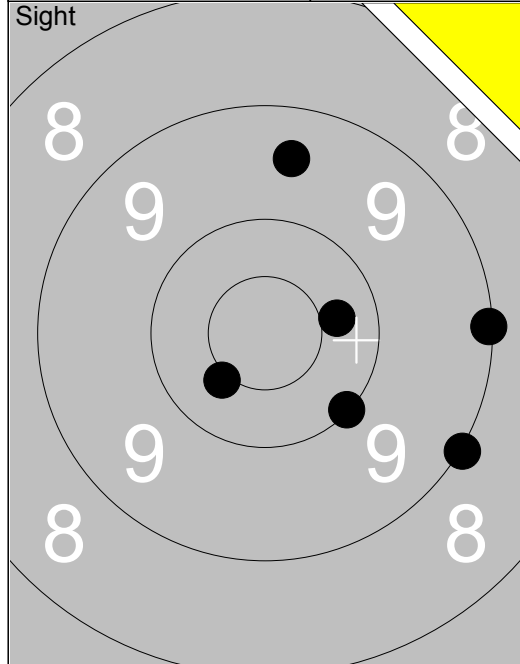

1:	9.1	→
2:	10.0	↘
3:	9.0	↘
4:	9.5	↑
5:	10.4	→
6:	*10.4	↘
Series		57.0
Total		0.0

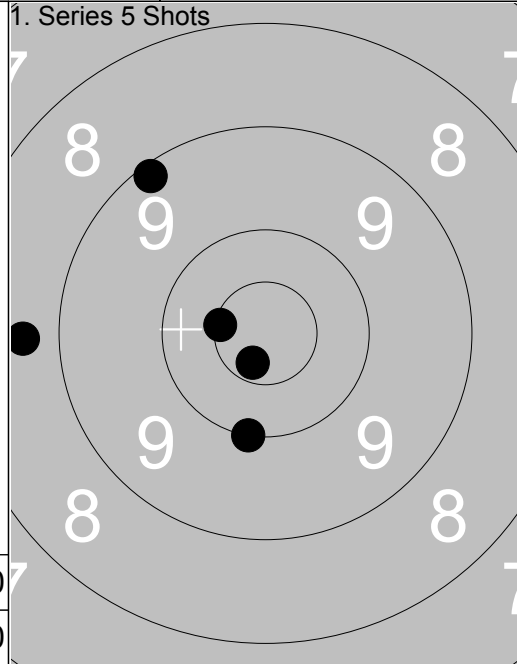

1:	9.1	↖
2:	*10.7	↘
3:	*10.5	↖
4:	10.0	↘
5:	8.7	←
Series		47.0
Total		47.0

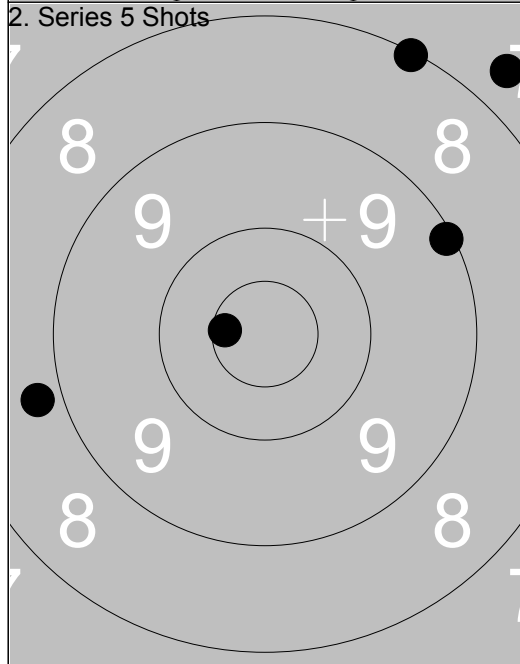

1:	8.1	↗
2:	9.1	→
3:	7.7	↗
4:	8.8	←
5:	*10.6	↖
Series		42.0
Total		89.0

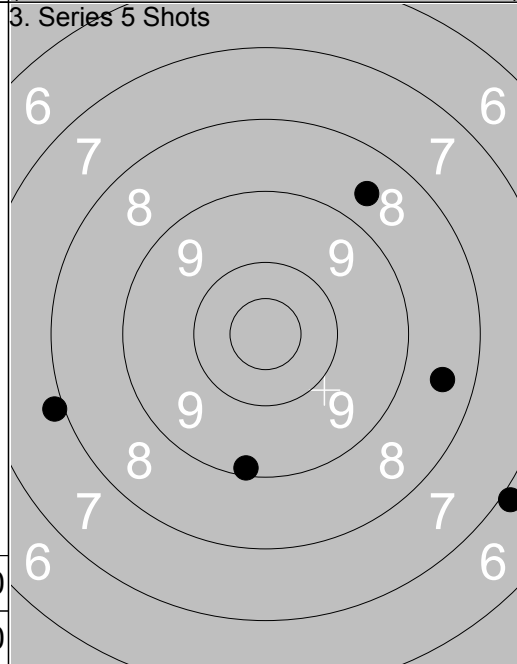

1:	6.9	↘
2:	9.1	↓
3:	8.6	↗
4:	7.9	←
5:	8.5	→
Series		38.0
Total		127.0

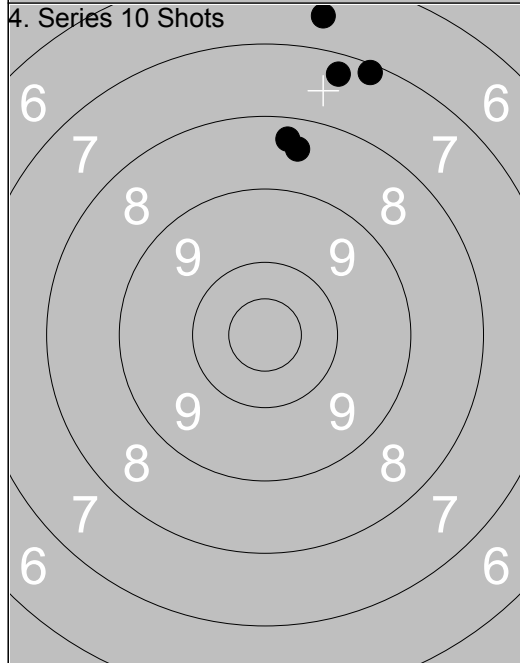

1:	7.3	↑
2:	8.4	↑
3:	7.1	↑
4:	6.6	↑
5:	8.3	↑
Series		36.0
Total		163.0

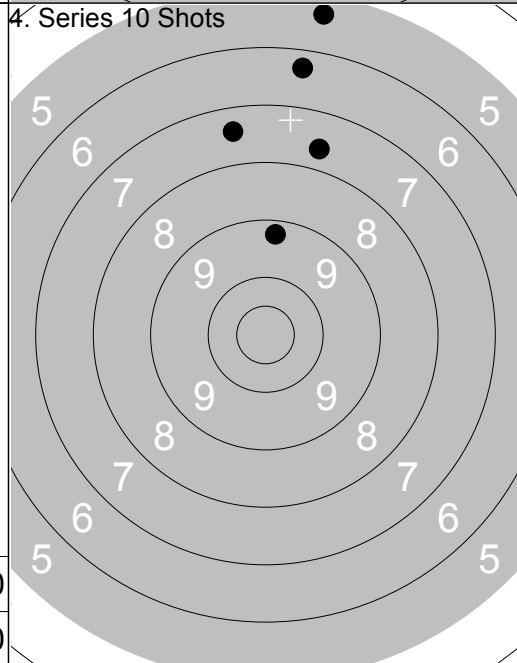

6:	5.4	↑
7:	7.4	↑
8:	7.7	↑
9:	9.3	↑
10:	6.3	↑
Series		34.0
Total		197.0

Relay **1** Lane **12** **Jorun Knutsson**

300m Kvistbro D Ör

07.07.2014 Tavelträffen B 2014 Ramselefors SKF

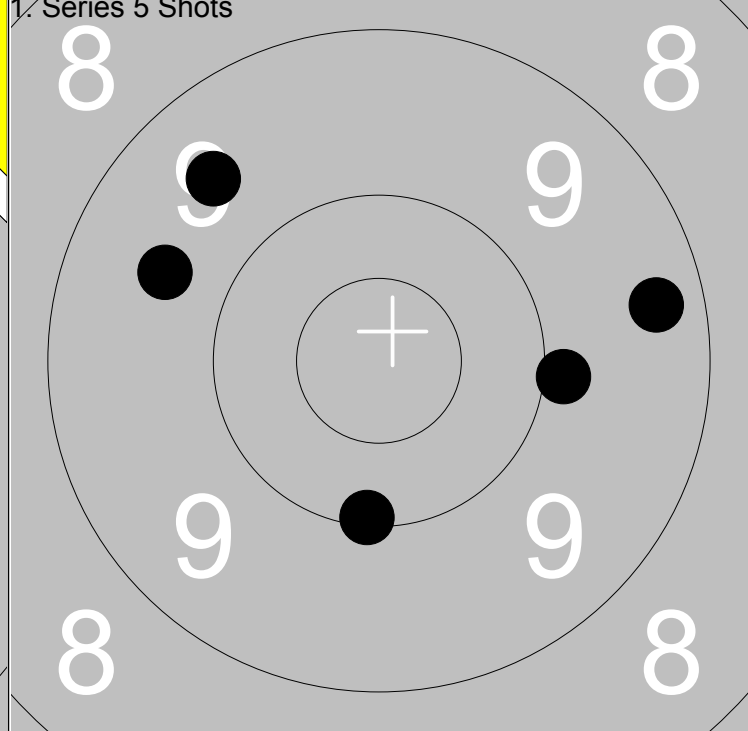
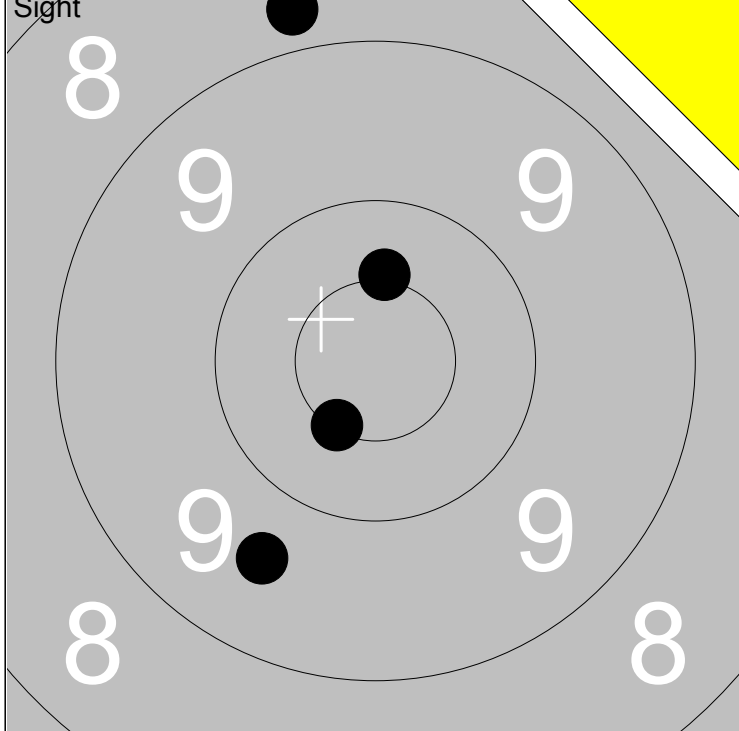

1: *10.5↑	Series	37.0
2: 8.8 ↑		
3: 9.6 ↓	Total	0.0
4: *10.5↓		

1: 9.5 ↖	Series	46.0
2: 9.3 →		
3: 9.9 →	Total	46.0
4: 9.6 ↖		
5: 10.1 ↓		

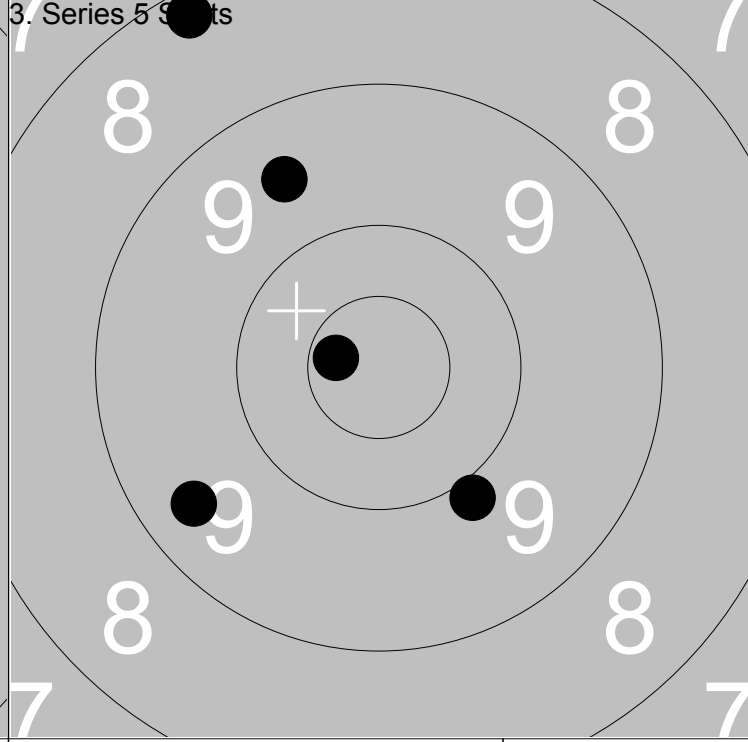
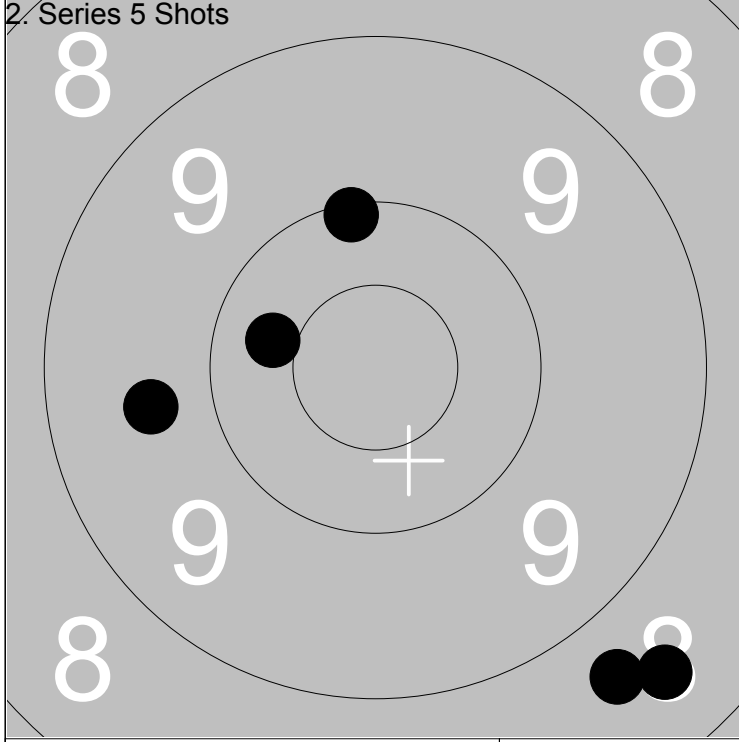

1: 8.7 ↓	Series	45.0
2: 10.1 ↑		
3: 8.5 ↓	Total	91.0
4: 10.4 ←		
5: 9.7 ←		

1: 9.9 ↓	Series	45.0
2: 8.2 ↖		
3: 9.5 ↖	Total	136.0
4: *10.7←		
5: 9.4 ↖		

Relay **1** Lane **13** **Markus Andersson**

300m Bälinge-Jumkil B Up

07.07.2014 Tavelträffen B 2014 Ramselefors SKF

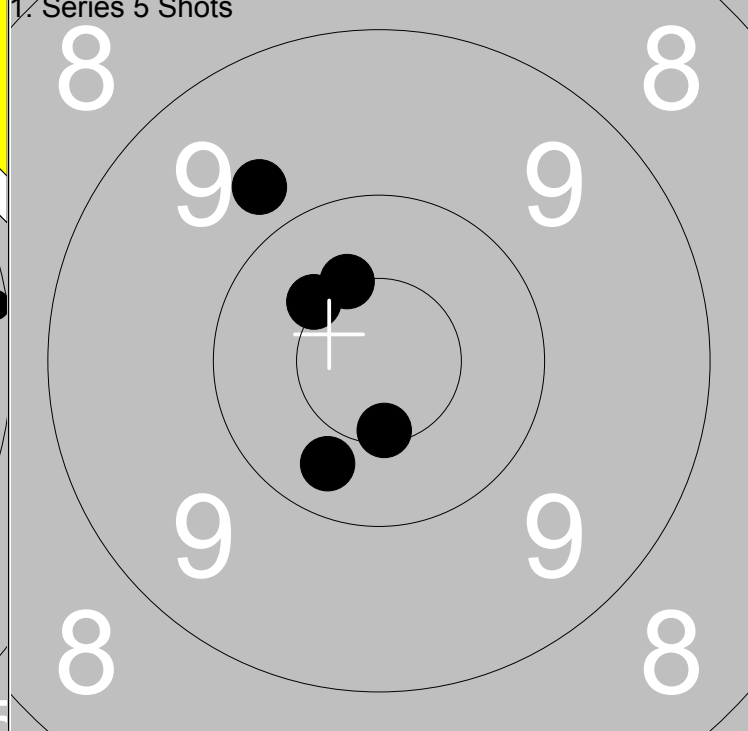
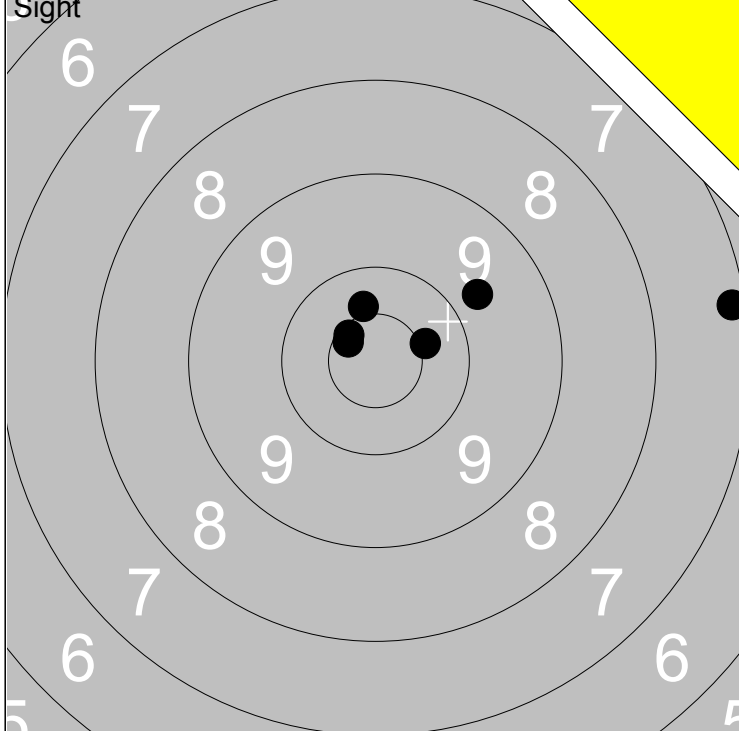

1: 10.4 ↑
2: *10.6 ↘
3: 9.7 ↗
4: *10.4 →
5: *10.6 ↘

6: 7.2 →
----------

Series	56.0
Total	0.0

1: 10.3 ↓
2: 9.8 ↖
3: *10.5 ↑
4: *10.5 ↘
5: *10.6 ↓

Series	49.0
Total	49.0

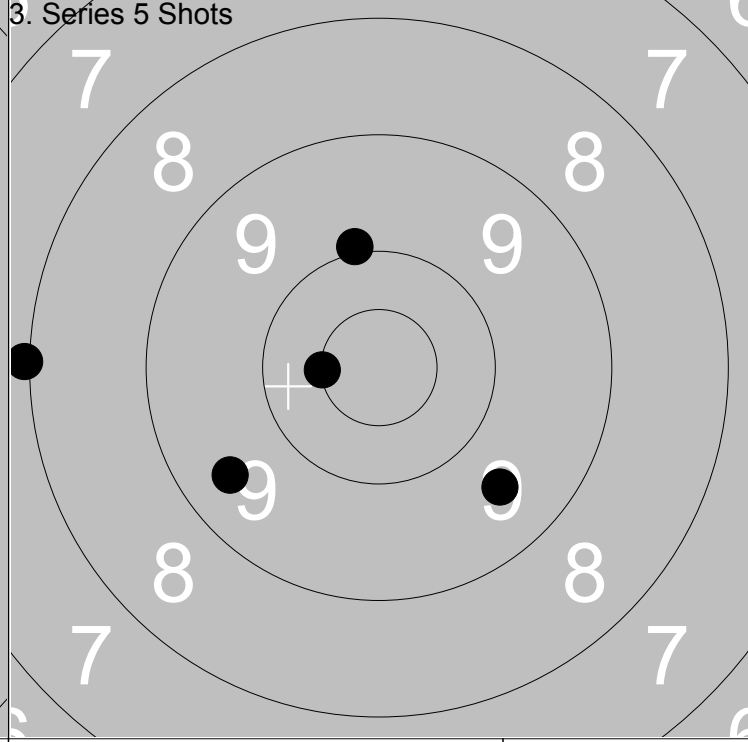
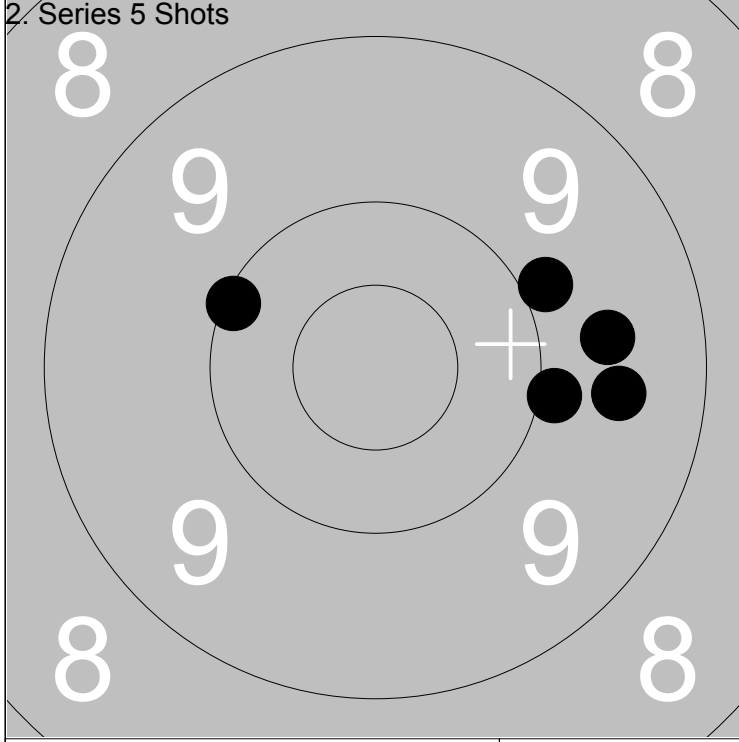

1: 9.9 ↗
2: 9.9 →
3: 9.6 →
4: 10.1 ↖
5: 9.6 →

Series	46.0
Total	95.0

1: 8.0 ←
2: *10.5 ←
3: 9.6 ↓
4: 10.0 ↑
5: 9.5 ↘

Series	46.0
Total	141.0

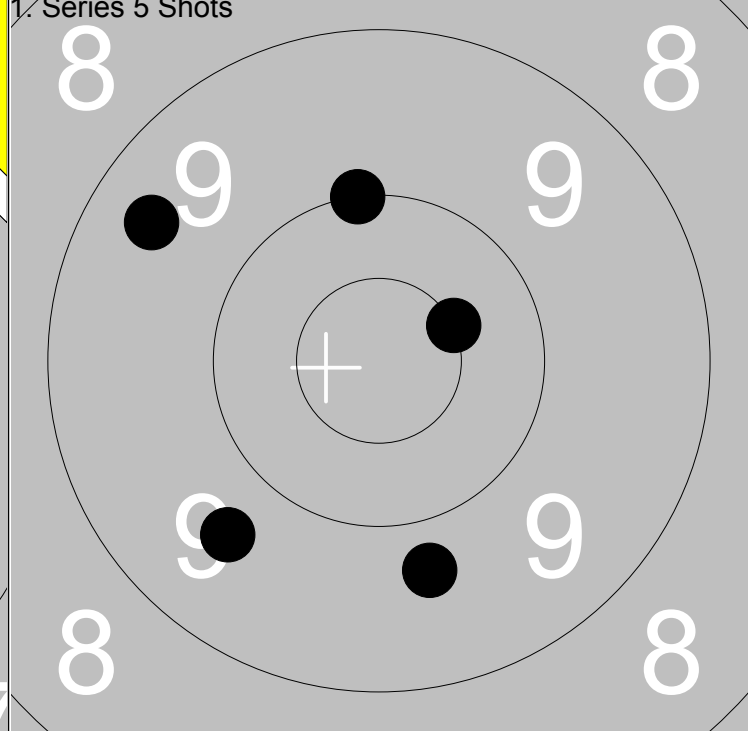
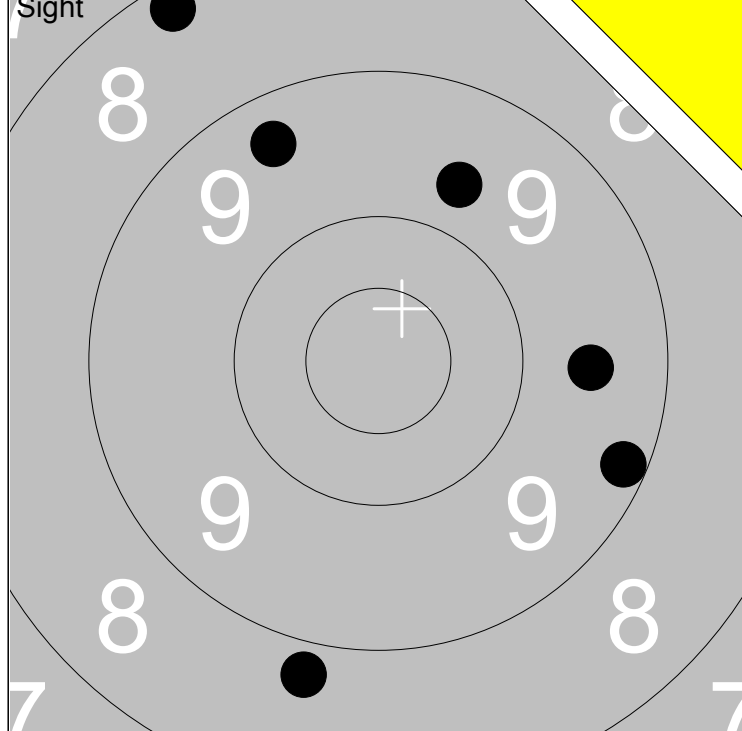

1: 9.6 →	6: 8.8 ↓		
2: 9.2 →		Series	52.0
3: 9.7 ↑			
4: 9.4 ↑		Total	0.0
5: 8.2 ↑			

1: 9.6 ↙			
2: 10.0 ↑		Series	47.0
3: 9.4 ↖			
4: *10.5 →		Total	47.0
5: 9.7 ↓			

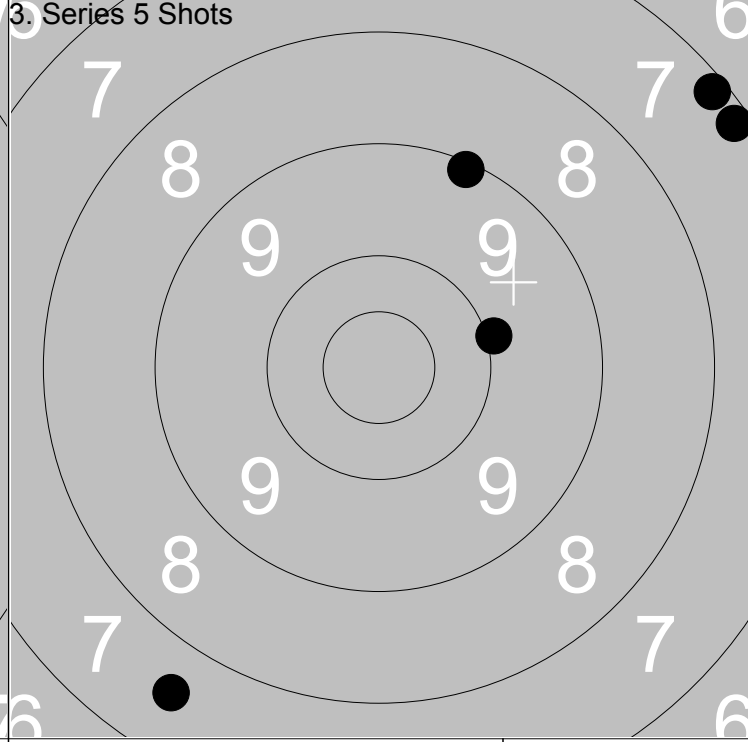
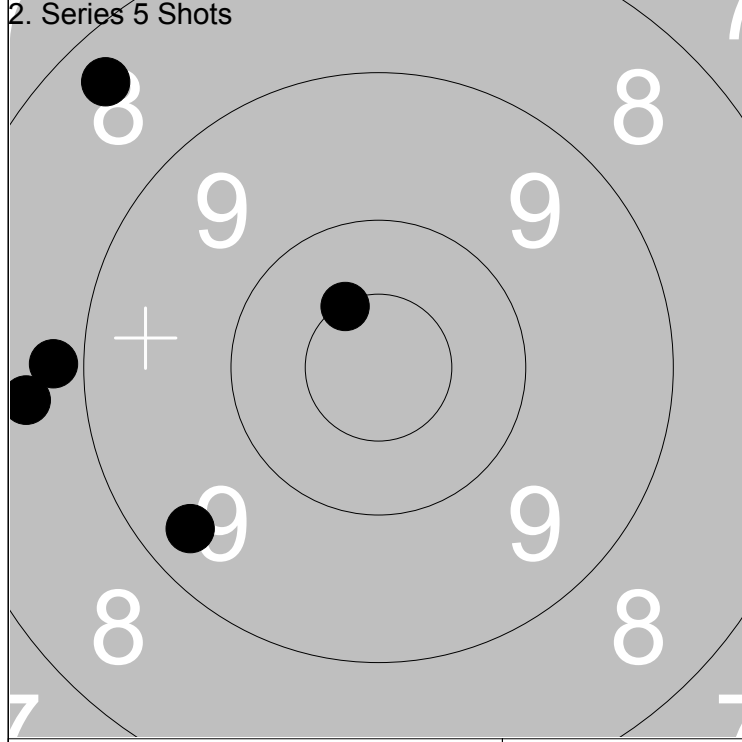

1: 8.8 ←			
2: 8.6 ←		Series	43.0
3: *10.5 ↖			
4: 8.3 ↖		Total	90.0
5: 9.4 ↙			

1: 7.2 ↗			
2: 7.6 ↙		Series	40.0
3: 9.1 ↑			
4: 7.2 ↗		Total	130.0
5: 10.0 →			

Relay	Lane	Peter Östling	
1	15		

300m	F 21	A	No
------	------	---	----

07.07.2014	Tavelträffen B 2014	Ramselefors SKF
------------	---------------------	-----------------

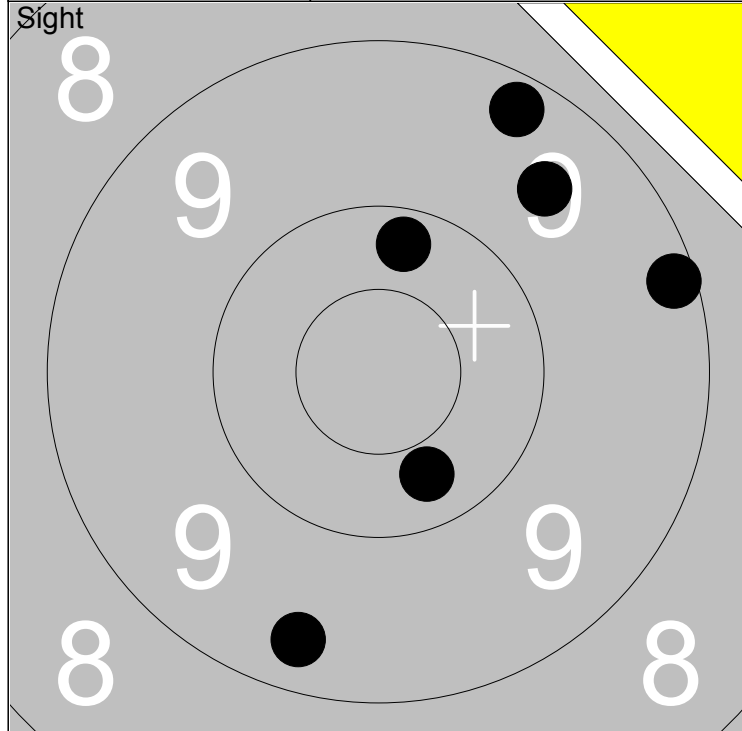

1: 9.3 ↓	6: 9.2 →	Series	56.0
2: 10.3 ↓		Total	0.0
3: 9.5 ↗			
4: 10.2 ↑			
5: 9.2 ↗			

1: *10.6 ↑	Series	49.0
2: *10.7 ←	Total	49.0
3: *10.5 ↑		
4: *10.9 ↗		
5: 9.0 ↓		

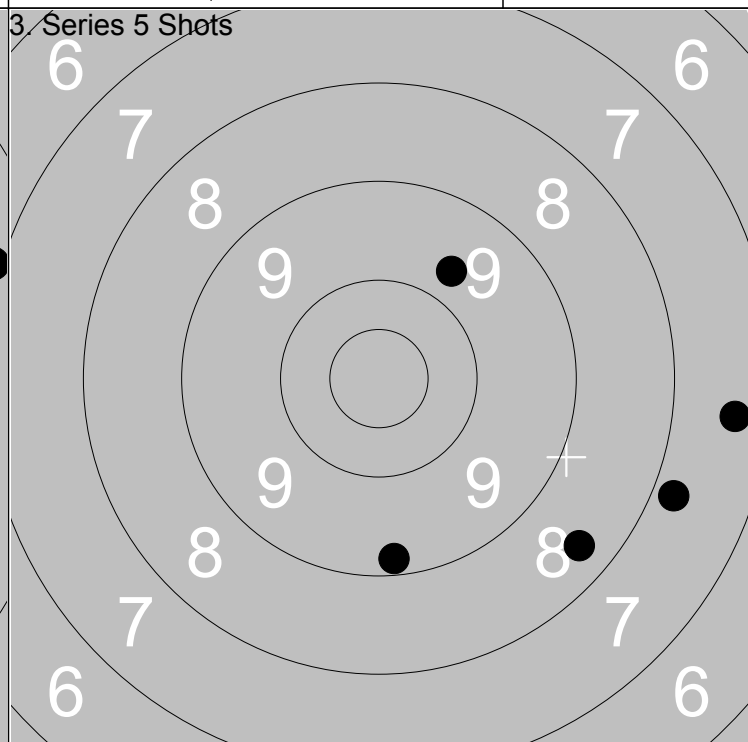
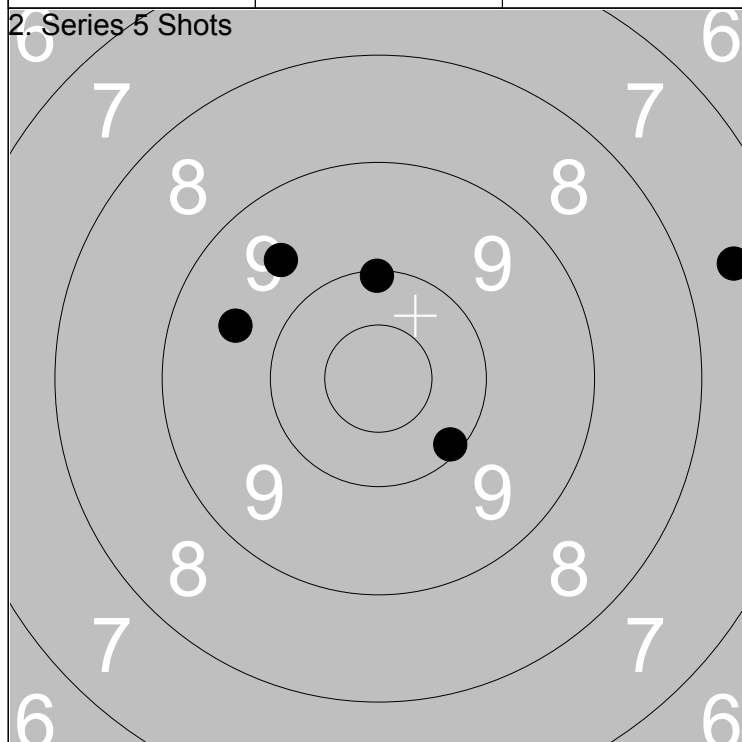

1: 10.1 ↑	Series	45.0
2: 9.6 ←	Total	94.0
3: 7.6 →		
4: 9.6 ↗		
5: 10.1 ↓		

1: 7.8 →	Series	40.0
2: 7.4 →	Total	134.0
3: 9.7 ↗		
4: 8.4 ↓		
5: 9.2 ↓		

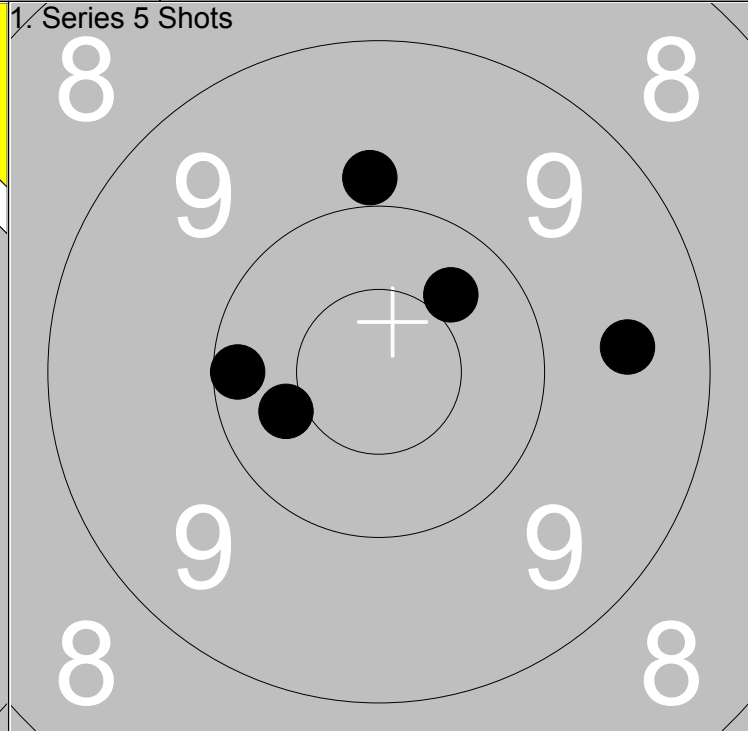
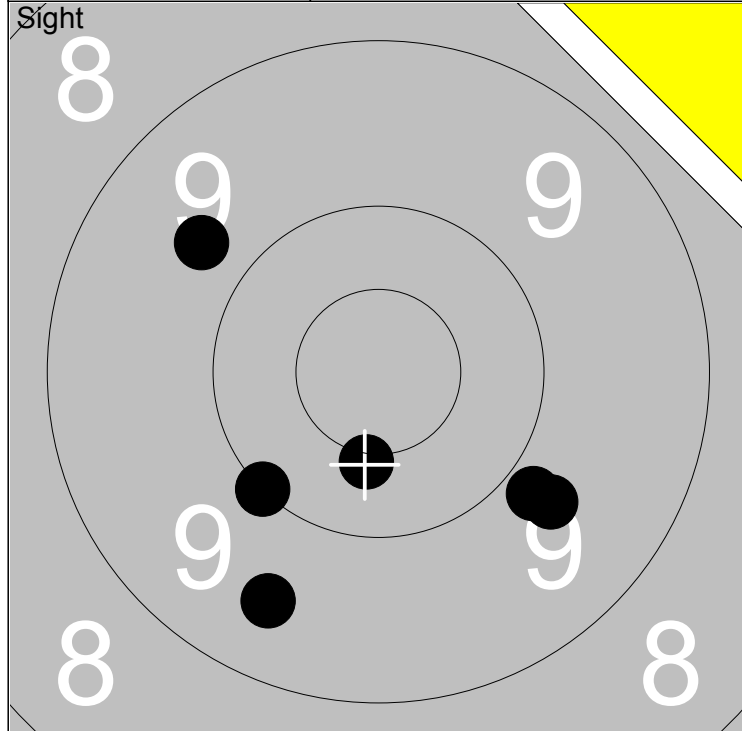

1: 10.0 ↙	6: 9.7 ↖	Series	56.0
2: 9.5 ↘		Total	0.0
3: *10.4 ↓			
4: 9.8 ↘			
5: 9.7 ↘			

1: 9.5 →	Series	48.0
2: 9.9 ↑	Total	48.0
3: 10.2 ←		
4: 10.4 ↗		
5: 10.4 ↙		

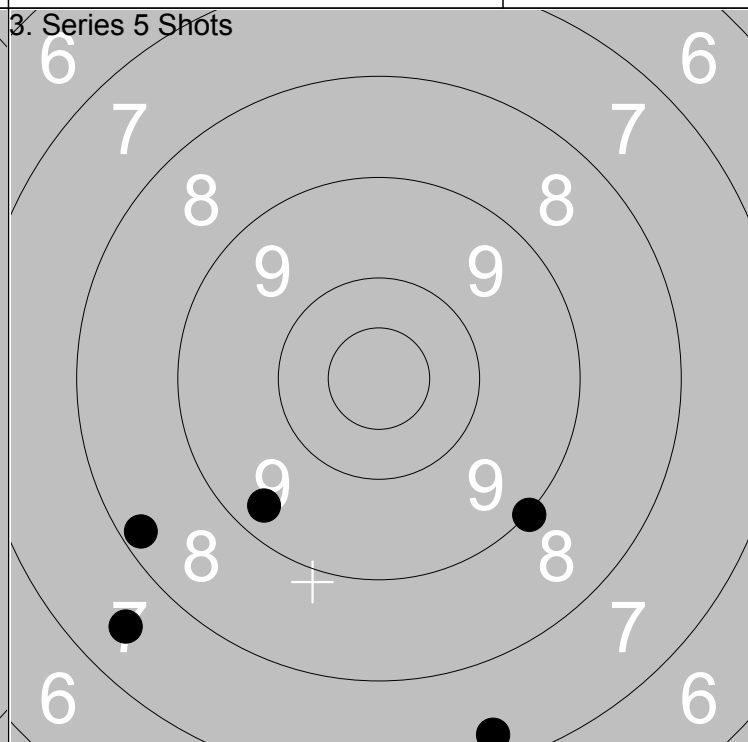
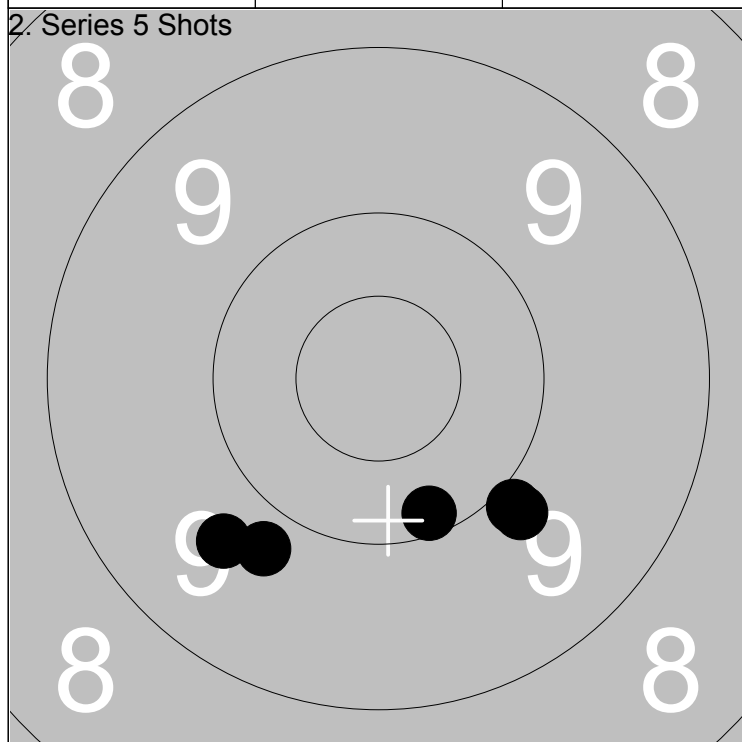

1: 10.1 ↓	Series	46.0
2: 9.9 ↘	Total	94.0
3: 9.8 ↘		
4: 9.9 ↘		
5: 9.7 ↘		

1: 9.0 ↘	Series	40.0
2: 7.5 ↘	Total	134.0
3: 9.3 ↘		
4: 7.3 ↘		
5: 8.2 ↙		

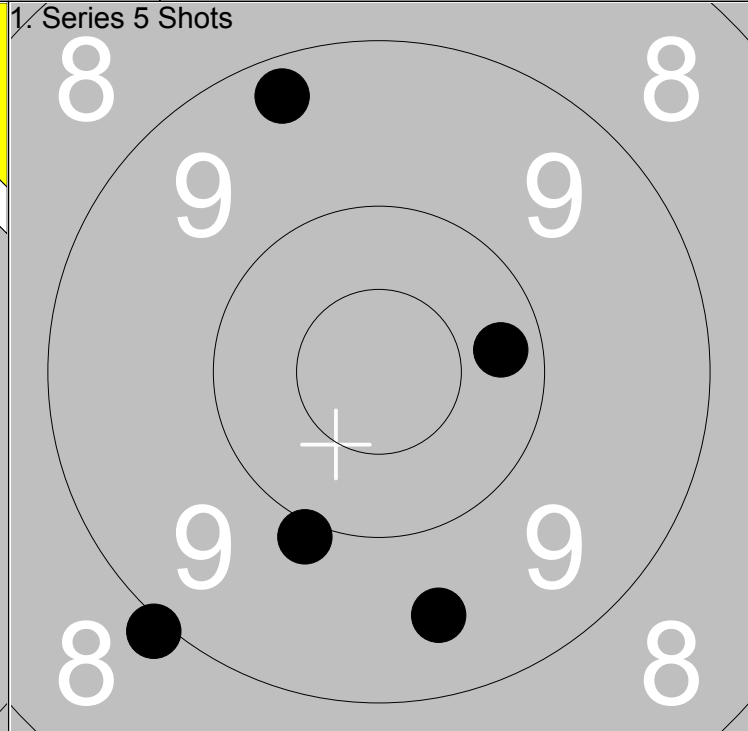
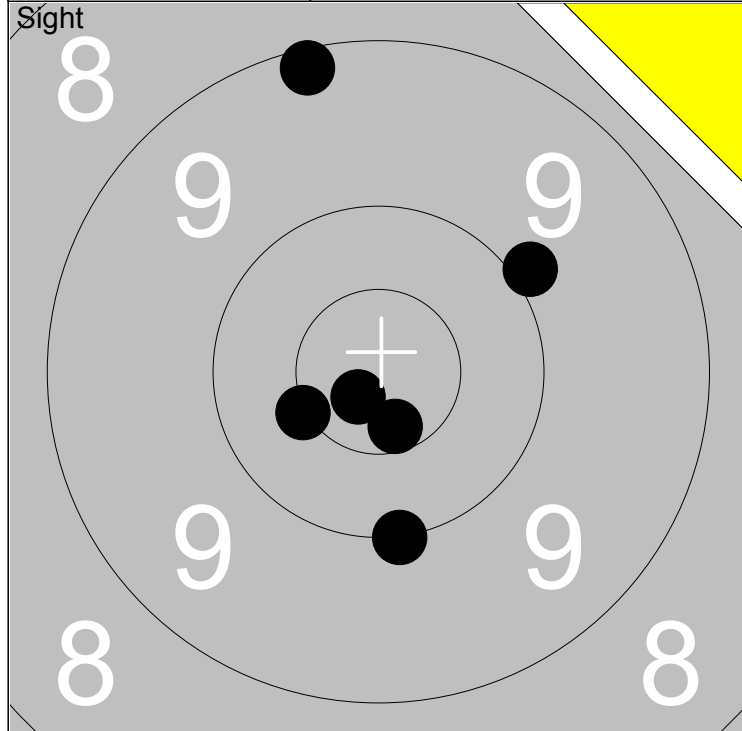

1: 9.1 ↑	6: *10.6 ↓		
2: 9.9 ↗		Series	58.0
3: *10.8 ↘			
4: 10.0 ↓		Total	0.0
5: *10.5 ↘			

1: 10.3 →			
2: 9.9 ↓		Series	46.0
3: 9.3 ↑			
4: 9.0 ↘		Total	46.0
5: 9.5 ↓			

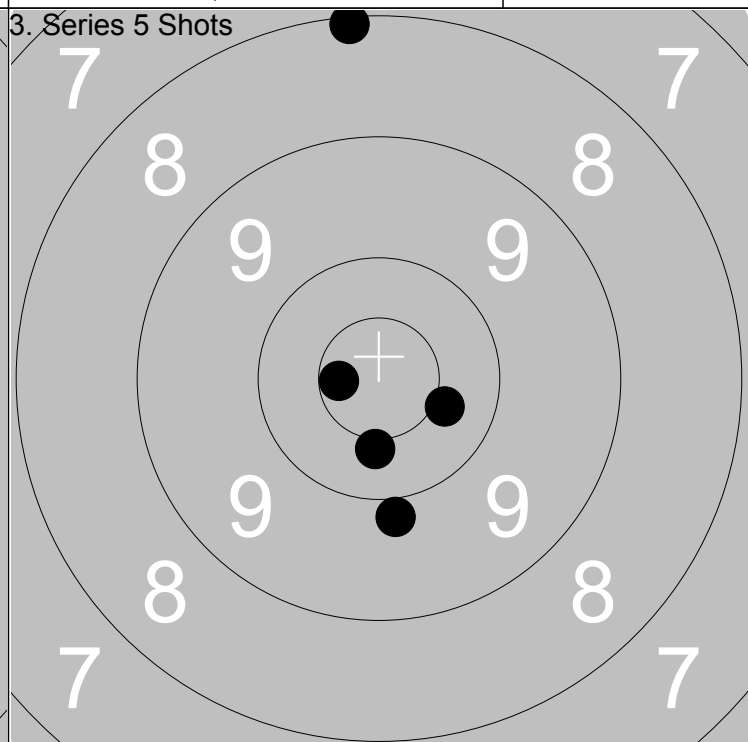
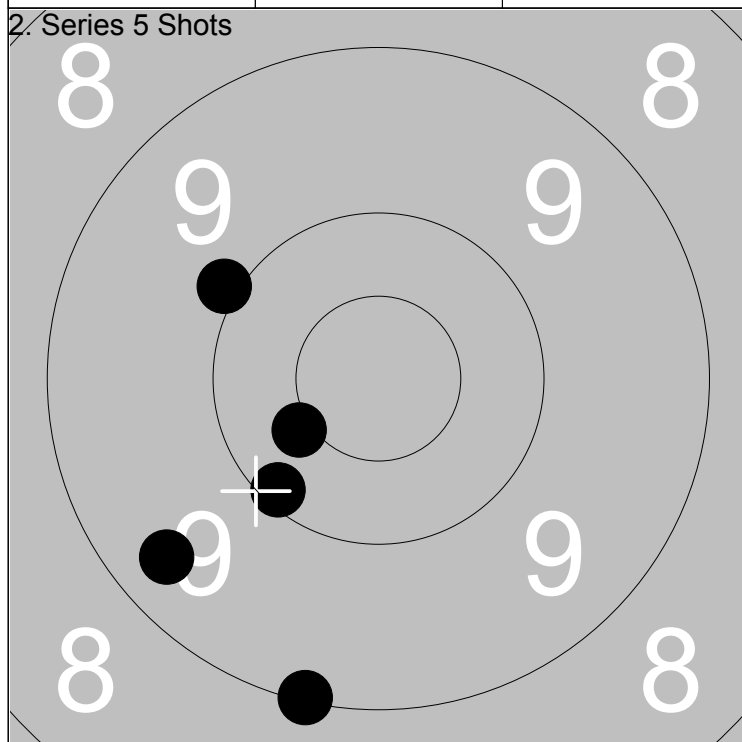

1: 9.4 ↘			
2: 9.9 ↖		Series	47.0
3: 9.1 ↓			
4: 10.1 ↘		Total	93.0
5: *10.4 ↘			

1: 8.1 ↑			
2: *10.4 ↓		Series	47.0
3: *10.6 ←			
4: 9.9 ↓		Total	140.0
5: 10.4 ↗			



<p>Sight</p>	<p>1. Series 5 Shots</p>	<p>1: *10.6 ↘</p> <p>2: 10.2 ↘</p> <p>3: 9.5 ↘</p> <p>4: 10.1 ↘</p> <p>5: 9.1 ↗</p> <p>6: *10.6 ↘</p>
Series 58.0	Series 48.0	
Total 0.0	Total 48.0	

<p>2. Series 5 Shots</p>	<p>3. Series 5 Shots</p>	<p>1: 9.7 ↘</p> <p>2: 8.9 ↘</p> <p>3: 9.5 ↗</p> <p>4: *10.8 ↘</p> <p>5: 10.1 ←</p>
Series 46.0	Series 44.0	
Total 94.0	Total 138.0	

<p>4. Series 10 Shots</p>	<p>4. Series 10 Shots</p>	<p>1: 9.9 →</p> <p>2: 7.7 →</p> <p>3: 7.1 →</p> <p>4: 7.6 →</p> <p>5: 8.1 →</p>
Series 38.03	Series 30.0	
Total 176.0	Total 206.0	

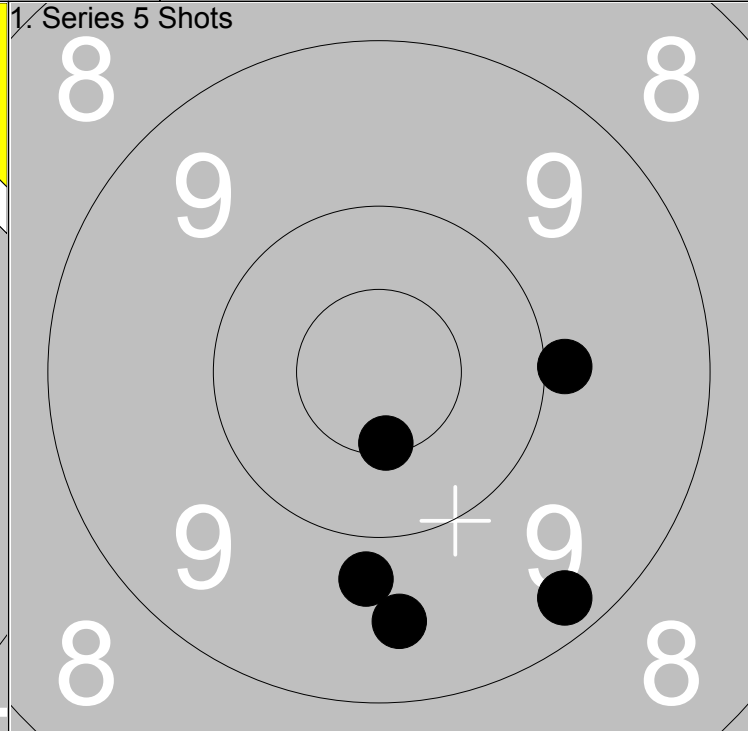
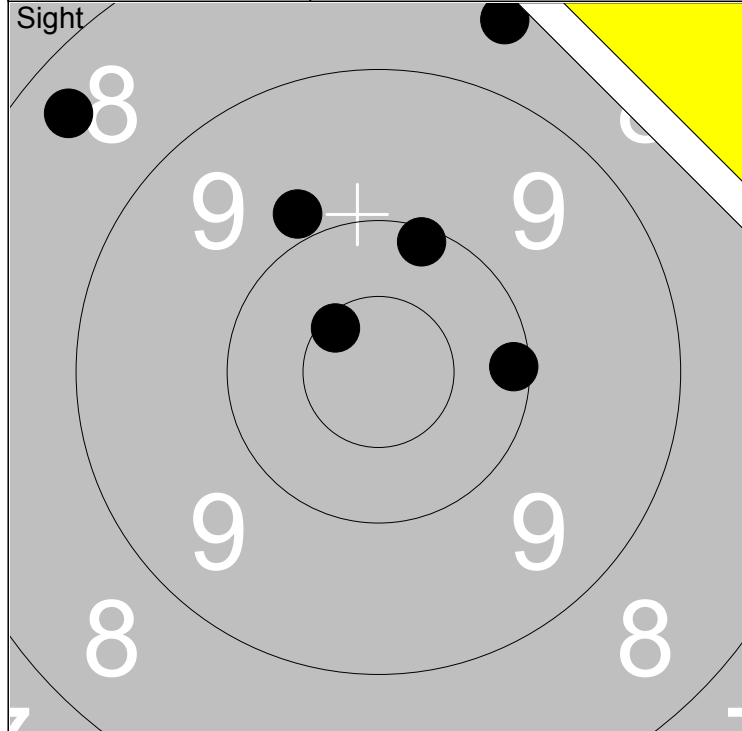

1: *10.6 ↖	6: 8.6 ↗				
2: 9.9 ↗		Series	55.0		
3: 10.1 ↗					
4: 10.1 →		Total	0.0		
5: 8.4 ↖					

1: 9.8 ↓					
2: 9.9 →		Series	46.0		
3: *10.6 ↓					
4: 9.5 ↓		Total	46.0		
5: 9.3 ↘					

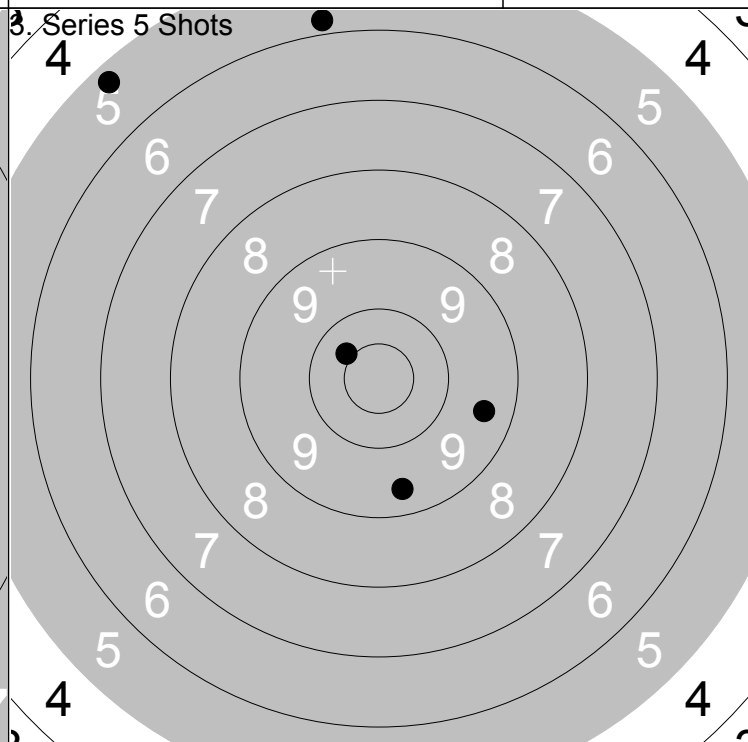
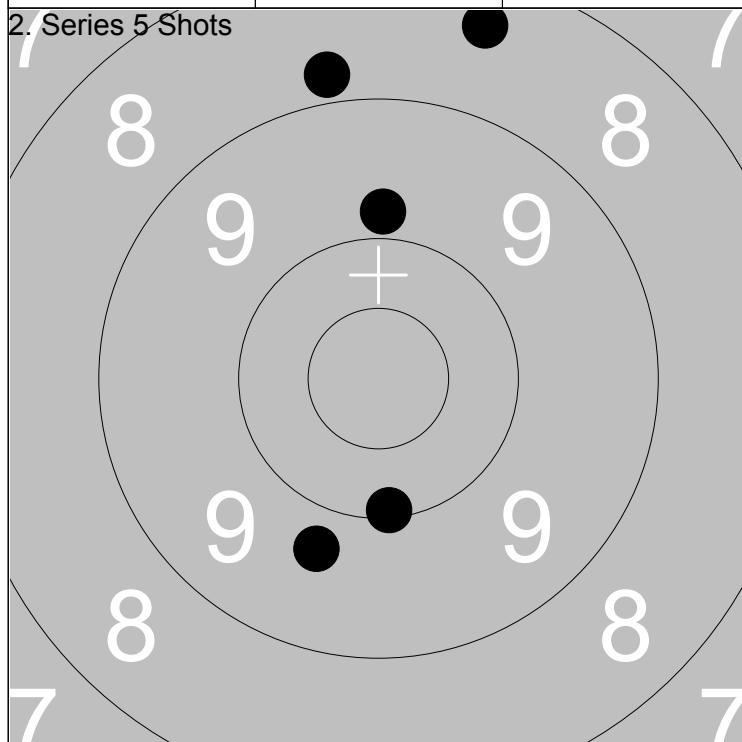

1: 8.4 ↗					
2: 8.8 ↗		Series	44.0		
3: 10.1 ↓					
4: 9.7 ↓		Total	90.0		
5: 9.8 ↗					

1: 5.3 ↖					
2: 5.8 ↗		Series	38.0		
3: 9.4 ↓					
4: 10.4 ↖		Total	128.0		
5: 9.5 →					

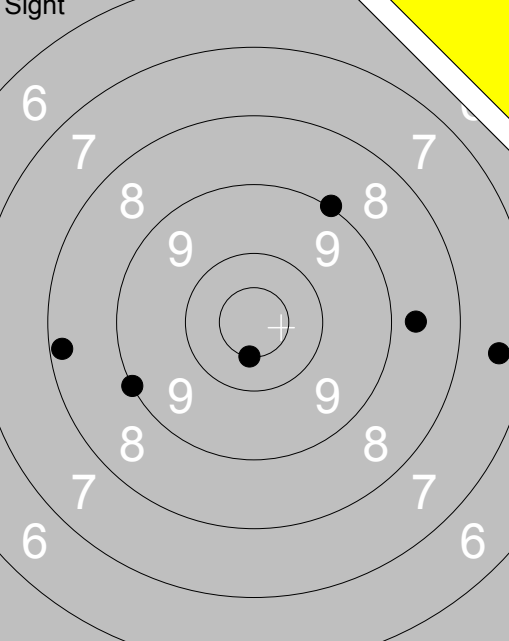
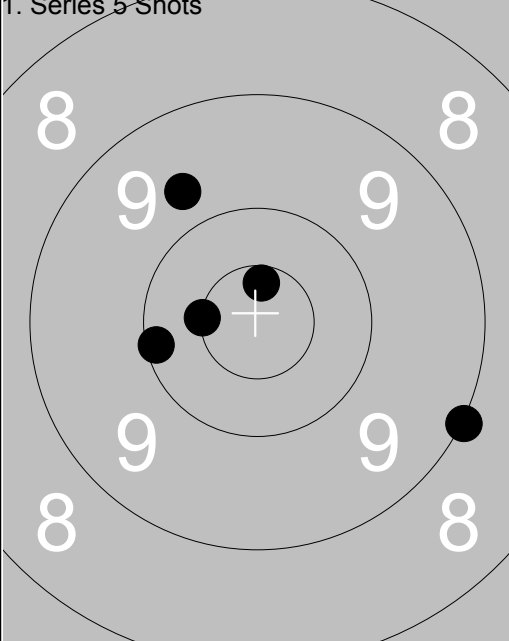
<p>Sight</p> 	<p>1: 8.2 ←</p> <p>2: 9.0 ↙</p> <p>3: *10.5 ↓</p> <p>4: 8.7 →</p> <p>5: 9.0 ↗</p> <p>6: 7.4 →</p>	<p>1. Series 5 Shots</p> 	<p>1: 9.7 ↗</p> <p>2: *10.6 ↗</p> <p>3: 10.1 ←</p> <p>4: *10.5 ←</p> <p>5: 9.0 →</p>
Series 51.0		Series 48.0	
Total 0.0		Total 48.0	

<p>2. Series 5 Shots</p> 	<p>1: 9.0 ↗</p> <p>2: *10.5 →</p> <p>3: 10.0 ↓</p> <p>4: 5.7 ←</p> <p>5: 8.9 ↓</p>	<p>3. Series 5 Shots</p> 	<p>1: 7.5 ←</p> <p>2: 6.0 ↙</p> <p>3: 7.4 ↓</p> <p>4: 3.9 ↗</p> <p>5: 6.4 ←</p>
Series 42.0		Series 29.0	
Total 90.0		Total 119.0	

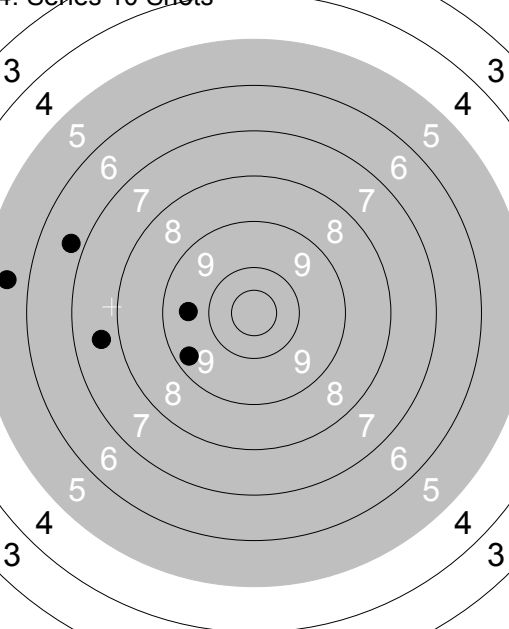
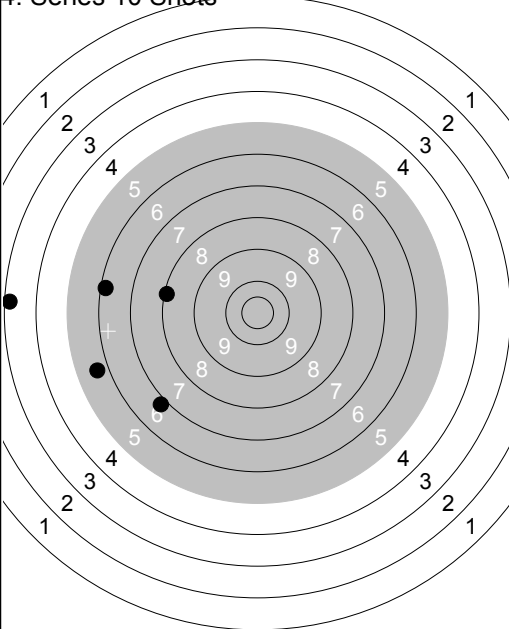
<p>4. Series 10 Shots</p> 	<p>1: 9.3 ↙</p> <p>2: 6.7 ←</p> <p>3: 9.6 ←</p> <p>4: 7.6 ←</p> <p>5: 5.6 ←</p>	<p>4. Series 10 Shots</p> 	<p>6: 8.1 ←</p> <p>7: 6.2 ←</p> <p>8: 6.8 ↙</p> <p>9: 5.6 ←</p> <p>10: 3.2 ←</p>
Series 36.0		Series 28.0	
Total 155.0		Total 183.0	

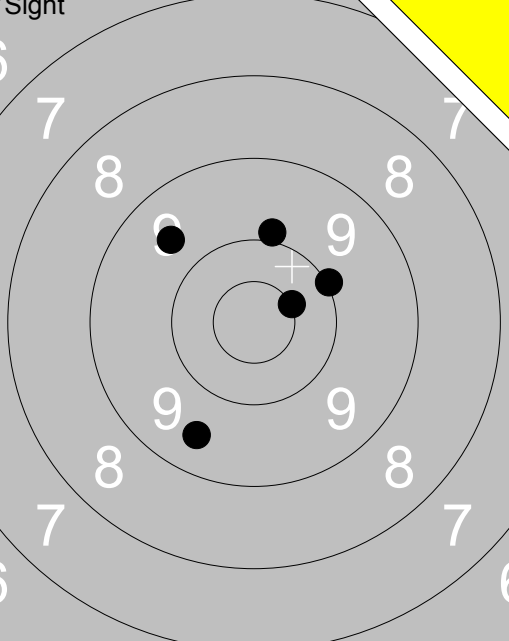
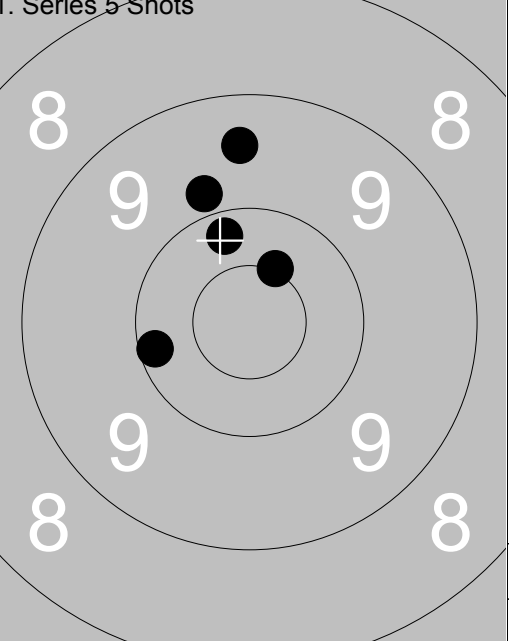
 <p>Sight</p>	<p>1: 9.9 ↑</p> <p>2: *10.5 →</p> <p>3: 10.0 →</p> <p>4: 9.6 ↖</p> <p>5: 7.0 ↗</p> <p>6: 9.5 ↓</p>	<p>1. Series 5 Shots</p> 	<p>1: 9.5 ↑</p> <p>2: 10.2 ←</p> <p>3: 9.8 ↑</p> <p>4: 10.2 ↑</p> <p>5: *10.5 ↗</p>
Series 54.0		Series 48.0	
Total 0.0		Total 48.0	

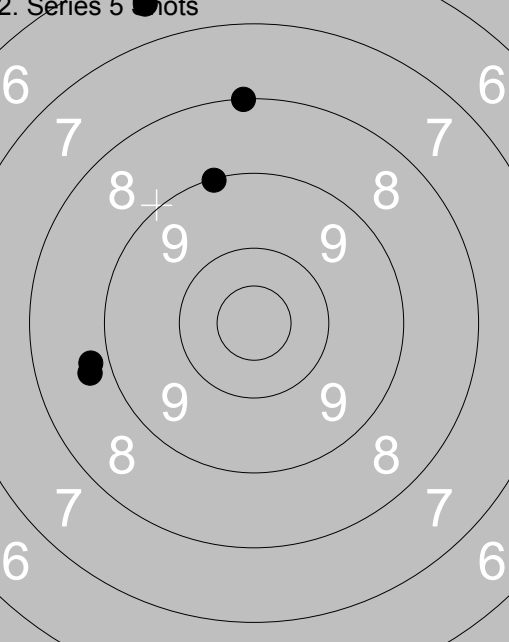
 <p>2. Series 5 Shots</p>	<p>1: 8.0 ↑</p> <p>2: 6.5 ↑</p> <p>3: 8.8 ←</p> <p>4: 8.7 ←</p> <p>5: 9.0 ↑</p>	<p>3. Series 5 Shots</p> 	<p>1: 8.7 ↖</p> <p>2: 8.4 ↖</p> <p>3: 10.3 ↑</p> <p>4: 7.5 ↗</p> <p>5: 8.6 ↘</p>
Series 39.0		Series 41.0	
Total 87.0		Total 128.0	

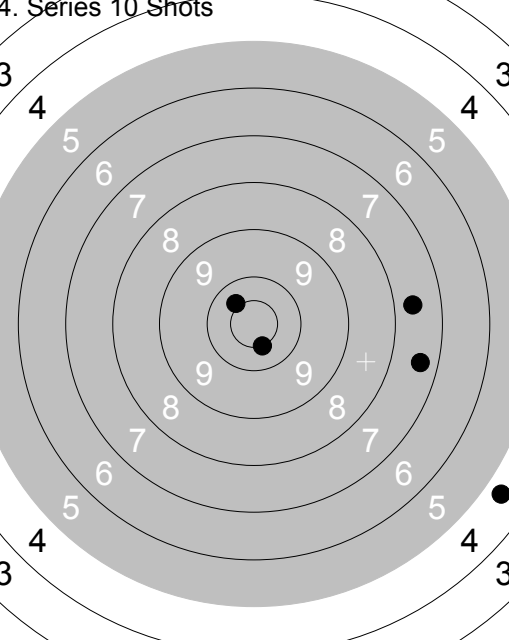
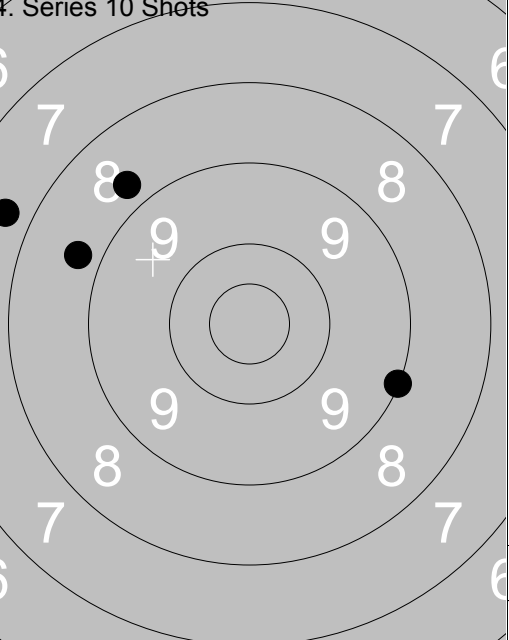
 <p>4. Series 10 Shots</p>	<p>1: *10.5 ↓</p> <p>2: *10.4 ↖</p> <p>3: 4.7 →</p> <p>4: 7.6 →</p> <p>5: 7.4 →</p>	<p>4. Series 10 Shots</p> 	<p>6: 8.7 ←</p> <p>7: 7.7 ←</p> <p>8: 8.7 ↗</p> <p>9: 9.0 →</p> <p>10: 0.0</p>
Series 38.0		Series 32.0	
Total 166.0		Total 198.0	

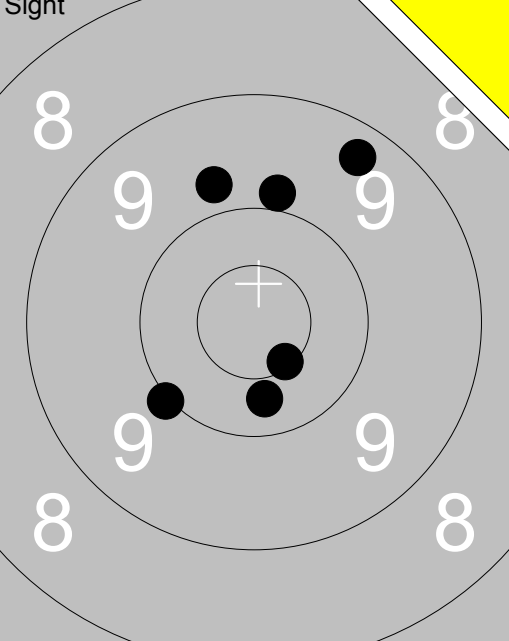
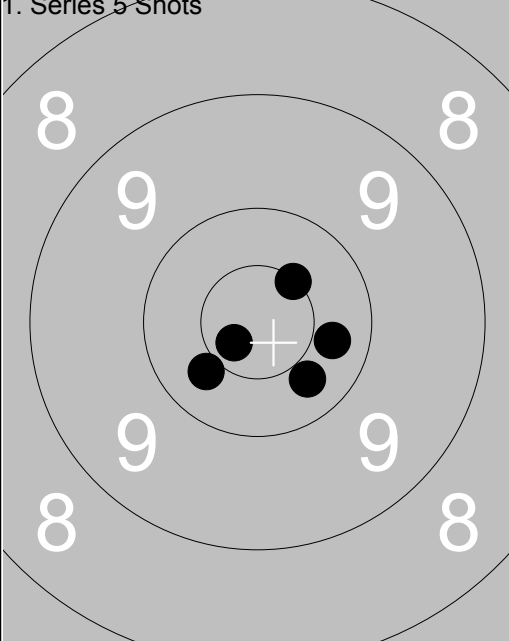
<p>Sight</p> 	<p>1. Series 5 Shots</p> 	<p>1: 9.8 ↗ 2: *10.5 ↘ 3: 9.3 ↗ 4: 9.9 ↑ 5: 10.3 ↓ 6: 10.0 ↙</p> <p>1: 10.3 ↘ 2: 10.3 → 3: 10.4 ↙ 4: *10.7 ↙ 5: *10.5 ↗</p>
Series 57.0	Series 50.0	
Total 0.0	Total 50.0	

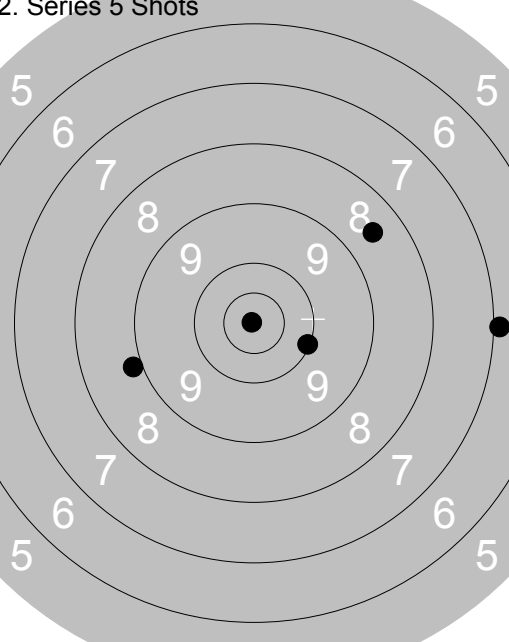
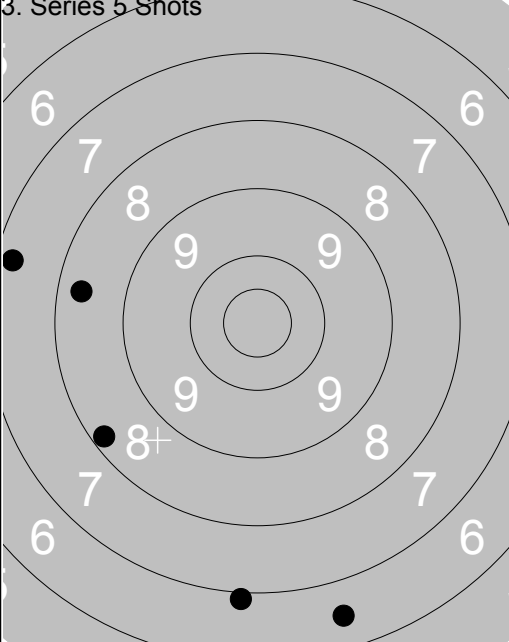
<p>2. Series 5 Shots</p> 	<p>3. Series 5 Shots</p> 	<p>1: 10.1 → 2: *10.9 ↙ 3: 8.5 ↗ 4: 6.9 → 5: 8.9 ←</p> <p>1: 6.9 ↓ 2: 7.3 ← 3: 8.2 ↙ 4: 8.4 ← 5: 6.5 ↓</p>
Series 42.0	Series 35.0	
Total 92.0	Total 127.0	

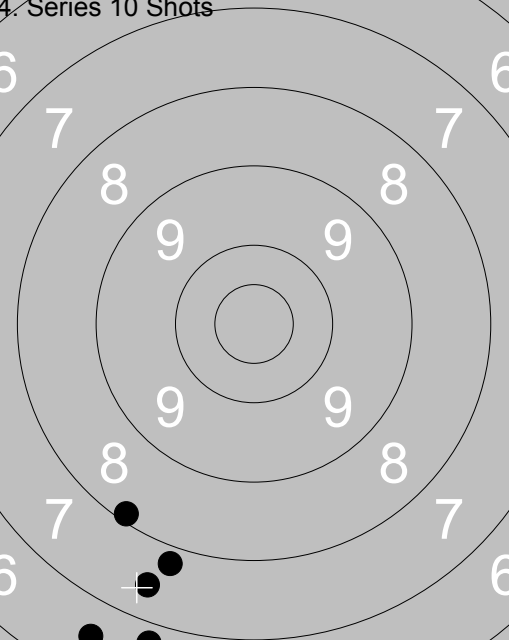
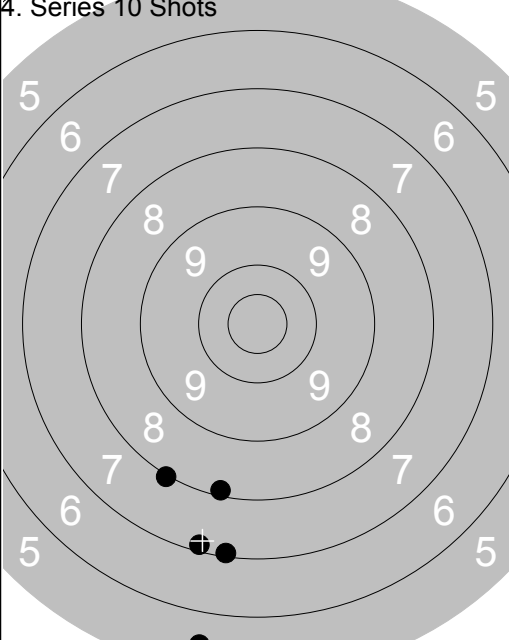
<p>4. Series 10 Shots</p> 	<p>4. Series 10 Shots</p> 	<p>1: 6.8 ↓ 2: 8.1 ↙ 3: 7.5 ↓ 4: 7.8 ↓ 5: 6.6 ↓</p> <p>6: 8.0 ↙ 7: 7.1 ↓ 8: 8.1 ↓ 9: 7.1 ↓ 10: 5.5 ↓</p>
Series 34.0	Series 35.0	
Total 161.0	Total 196.0	

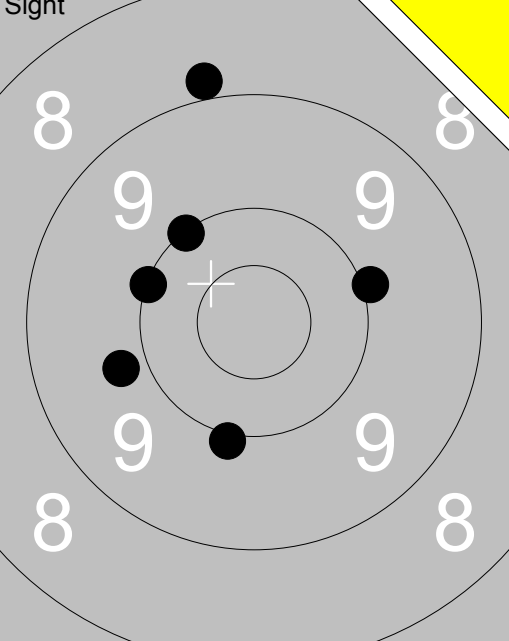
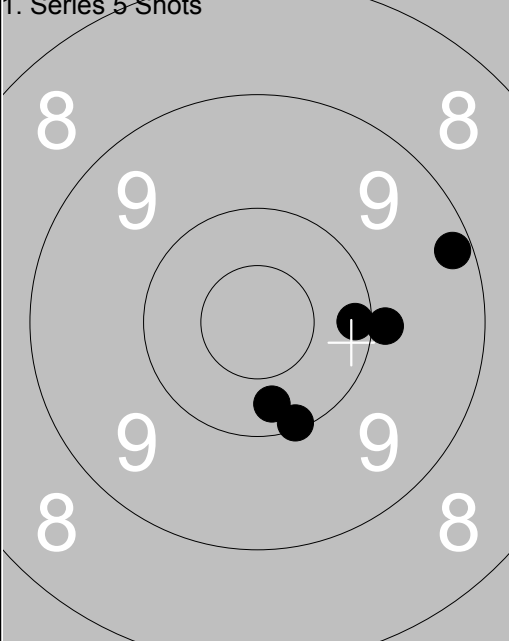
<p>Sight</p> 	<p>1: 9.8 ← 2: 10.0 ↖ 3: 10.0 → 4: 10.0 ↙ 5: 8.9 ↑ 6: 10.0 ↓</p>	<p>1. Series 5 Shots</p> 		<p>1: 9.2 → 2: 10.3 ↓ 3: 10.2 → 4: 9.9 → 5: 10.1 ↓</p>	
Series 57.0				Series 48.0	
Total 0.0				Total 48.0	

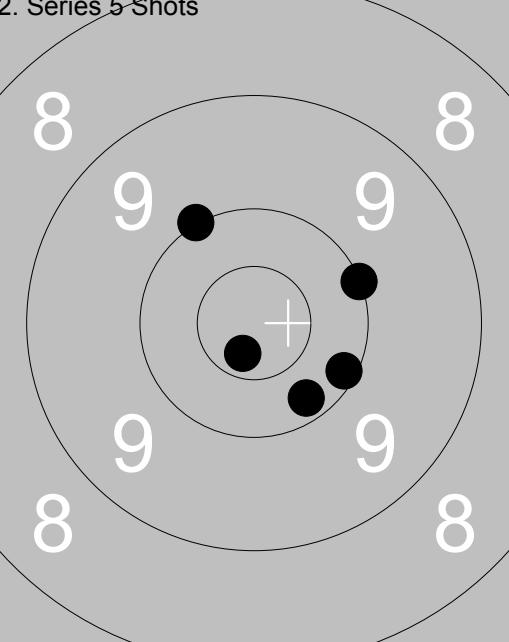
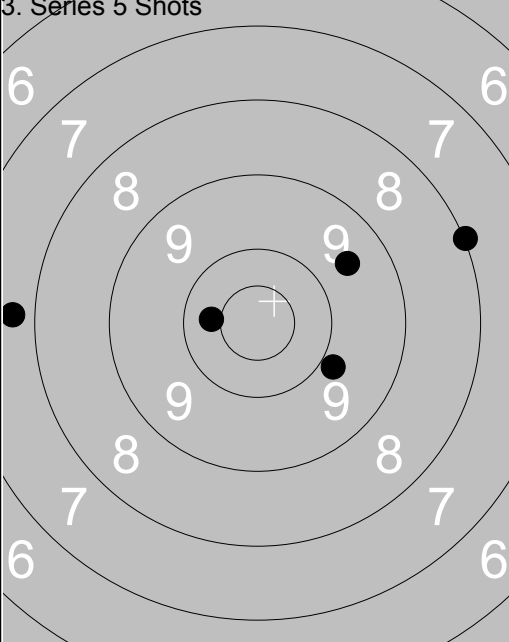
<p>2. Series 5 Shots</p> 	<p>1: 10.0 ↖ 2: 10.0 → 3: 10.1 → 4: *10.7 ↓ 5: 10.2 ↓</p>	<p>3. Series 5 Shots</p> 		<p>1: 8.0 → 2: 7.7 ← 3: 9.6 ↗ 4: 10.4 ← 5: 9.9 →</p>	
Series 50.0				Series 43.0	
Total 98.0				Total 141.0	

<p>4. Series 10 Shots</p> 	<p>1: 7.0 → 2: 7.4 → 3: 8.0 → 4: 5.0 → 5: 6.1 →</p>	<p>4. Series 10 Shots</p> 		<p>6: 7.1 → 7: 6.9 → 8: 7.5 → 9: 7.9 → 10: 10.3 ↙</p>	
Series 33.0				Series 37.0	
Total 174.0				Total 211.0	

<p>Sight</p>	<p>1. Series 5 Shots</p>	
1: 10.4 ↙ 2: 10.0 ↖ 3: *10.6 ↘ 4: 10.1 ↘ 5: 10.2 → 6: 9.4 ↓	1: 9.5 → 2: *10.5 → 3: 10.3 → 4: 10.2 ↑ 5: *10.6 ↘	
Series 59.0 Total 0.0	Series 49.0 Total 49.0	

<p>2. Series 5 Shots</p>	<p>3. Series 5 Shots</p>	
1: 10.2 ↓ 2: 10.1 ↙ 3: 9.0 → 4: 8.7 → 5: *10.5 ↙	1: 7.8 → 2: 8.0 → 3: 8.6 ↘ 4: 9.7 ↖ 5: 10.1 ↖	
Series 47.0 Total 96.0	Series 42.0 Total 138.0	

<p>4. Series 10 Shots</p>	<p>4. Series 10 Shots</p>	
1: 6.3 ↑ 2: 7.7 ↑ 3: 7.8 ↑ 4: 7.0 ↑ 5: 8.2 ↑	6: 7.1 ↑ 7: 6.7 ↑ 8: 6.6 ↑ 9: 9.3 ↑ 10: 7.2 ↑	
Series 35.0 Total 173.0	Series 35.0 Total 208.0	

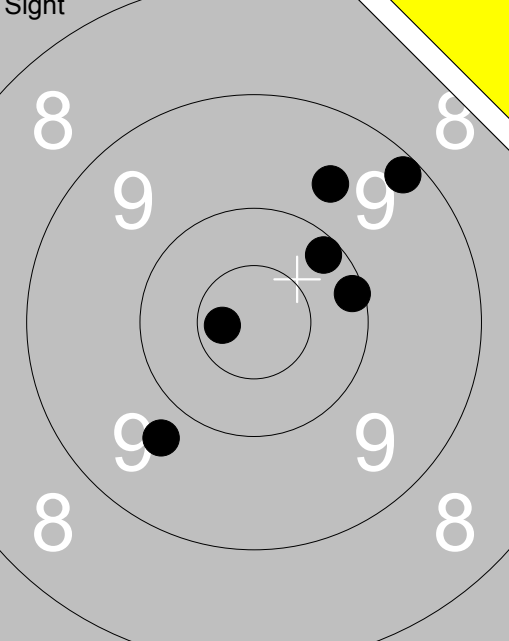
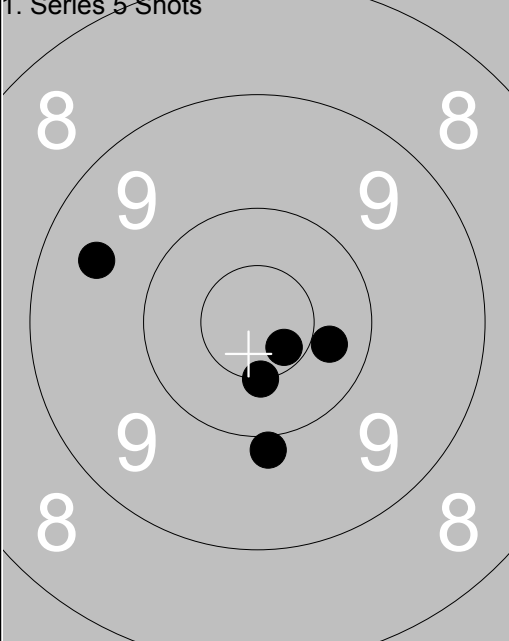
<p>Sight</p> 	<p>1. Series 5 Shots</p> 	<p>1: 10.2 ↗ 2: 9.6 ↗ 3: 9.2 ↗ 4: 10.1 → 5: 9.7 ↘ 6: *10.7 ←</p> <p>1: 9.5 ← 2: *10.7 ↘ 3: 9.9 ↓ 4: *10.5 ↓ 5: 10.3 →</p>
Series 57.0	Series 48.0	
Total 0.0	Total 48.0	

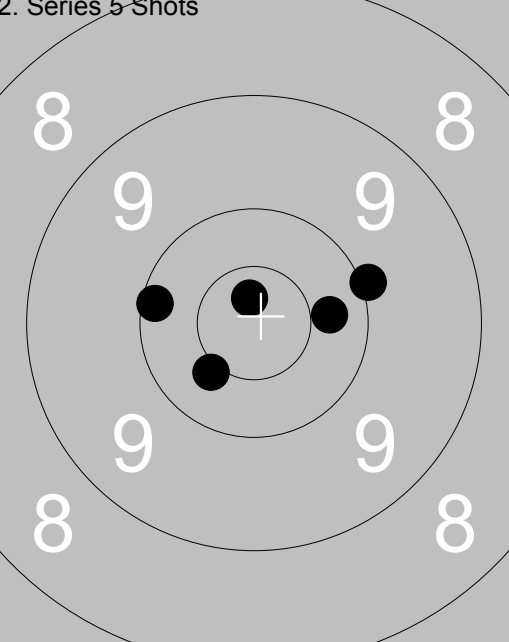
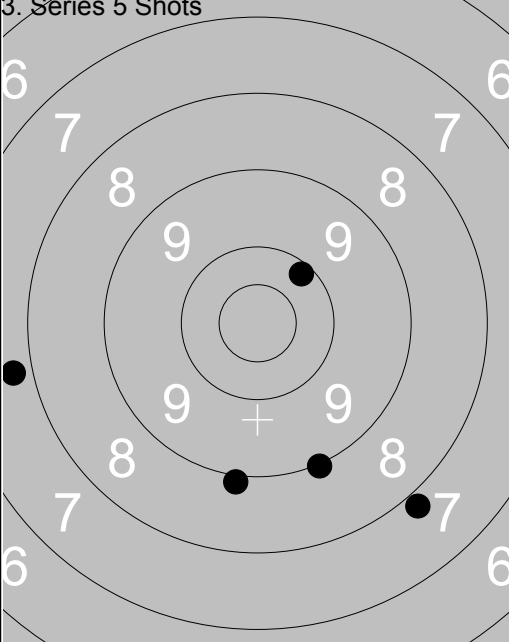
<p>2. Series 5 Shots</p> 	<p>3. Series 5 Shots</p> 	<p>1: 10.3 → 2: *10.4 ↘ 3: *10.7 ↑ 4: 10.1 ← 5: 10.0 →</p> <p>1: 10.2 ↗ 2: 7.8 ← 3: 8.9 ↓ 4: 7.9 ↘ 5: 9.0 ↓</p>
Series 50.0	Series 41.0	
Total 98.0	Total 139.0	

<p>4. Series 10 Shot</p> 	<p>4. Series 10 Shots</p> 	<p>1: 9.5 ↑ 2: 7.6 ↑ 3: 8.7 ↑ 4: 6.0 ↑ 5: 6.0 ↑</p> <p>6: 4.5 ↑ 7: 5.2 ↑ 8: 5.1 ↑ 9: 10.0 → 10: 10.0 →</p>
Series 36.0	Series 34.0	
Total 175.0	Total 209.0	



	<p>1: 8.9 →</p> <p>2: *10.7 ↘</p> <p>3: 9.8 ↗</p> <p>4: 9.3 →</p> <p>5: 8.1 ↑</p> <p>6: 9.2 ↖</p>	<p>1. Series 5 Shots</p>		<p>1: 10.1 ↑</p> <p>2: 9.6 ↑</p> <p>3: 8.5 ↑</p> <p>4: 8.8 ↖</p> <p>5: 9.9 ←</p>
Series 53.0				Series 44.0
Total 0.0				Total 44.0

<p>2. Series 5 Shots</p>	<p>1: 8.5 ↗</p> <p>2: 8.1 ↑</p> <p>3: 5.7 →</p> <p>4: 8.5 ←</p> <p>5: 6.7 →</p>	<p>3. Series 5 Shots</p>		<p>1: 8.8 →</p> <p>2: 5.1 ←</p> <p>3: 6.7 ↗</p> <p>4: 7.1 ↑</p> <p>5: 5.1 ↑</p>
Series 35.0				Series 31.0
Total 79.0				Total 110.0

<p>4. Series 10 Shots</p>	<p>1: 9.3 ←</p> <p>2: 6.3 ←</p> <p>3: 7.1 ←</p> <p>4: 6.3 ←</p> <p>5: 5.3 ←</p>	<p>4. Series 10 Shots</p>		<p>6: 6.8 ←</p> <p>7: 9.0 ↖</p> <p>8: 7.6 ↖</p> <p>9: 8.4 ←</p> <p>10: 7.5 ←</p>
Series 33.0				Series 37.0
Total 143.0				Total 180.0

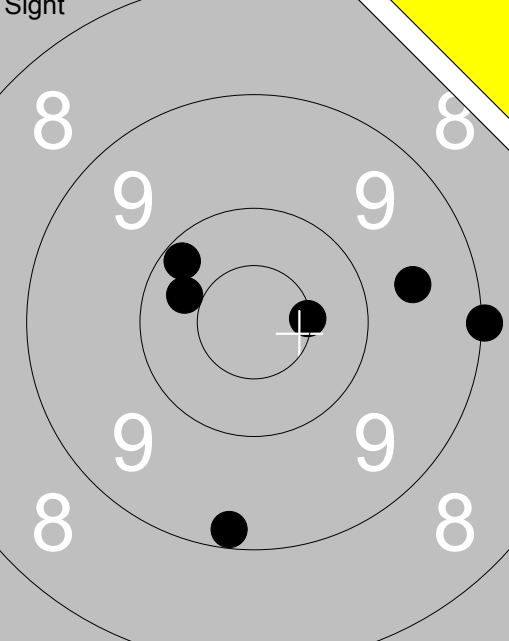
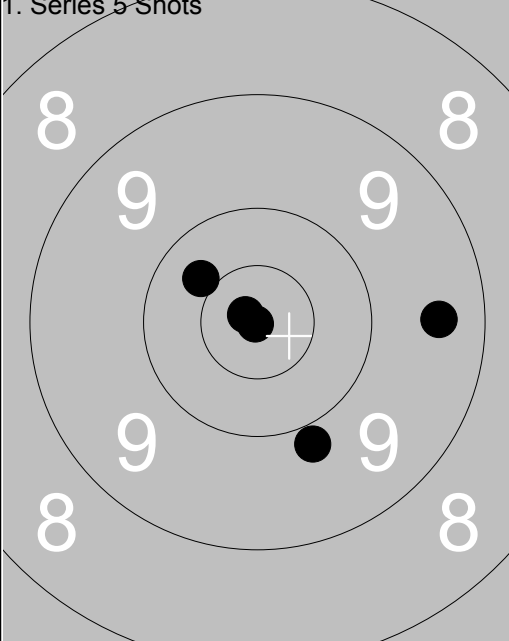
<p>Sight</p> 	<p>1: 10.3 ↙ 2: 10.2 ↗ 3: 9.6 → 4: *10.5 → 5: 9.0 → 6: 9.2 ↓</p>	<p>1. Series 5 Shots</p> 		<p>1: *10.9 ↘ 2: 9.4 → 3: 9.9 ↓ 4: 10.4 ↗ 5: *10.8 ↙</p>	
Series 57.0				Series 48.0	
Total 0.0				Total 48.0	

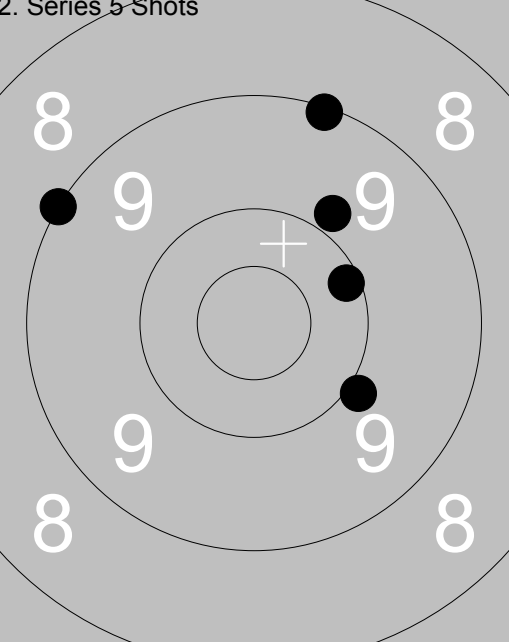
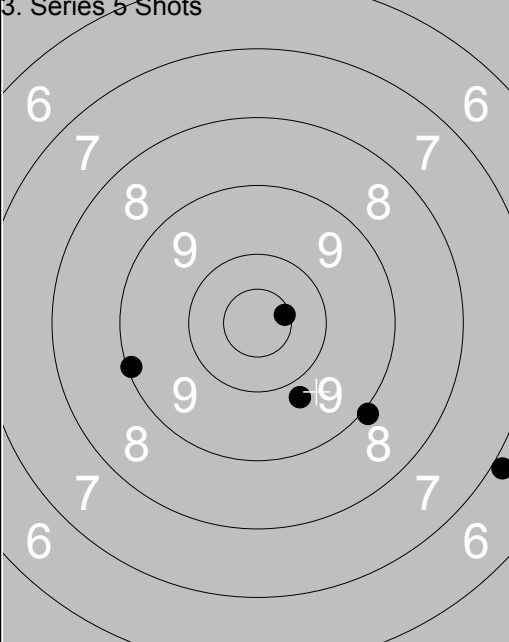
<p>2. Series 5 Shots</p> 	<p>1: 9.1 ↑ 2: 10.1 → 3: 9.8 ↗ 4: 9.0 ↙ 5: 9.9 ↘</p>	<p>3. Series 5 Shots</p> 		<p>1: 9.1 ↙ 2: 9.8 ↓ 3: *10.6 → 4: 8.9 ↘ 5: 6.9 ↘</p>	
Series 46.0				Series 42.0	
Total 94.0				Total 136.0	

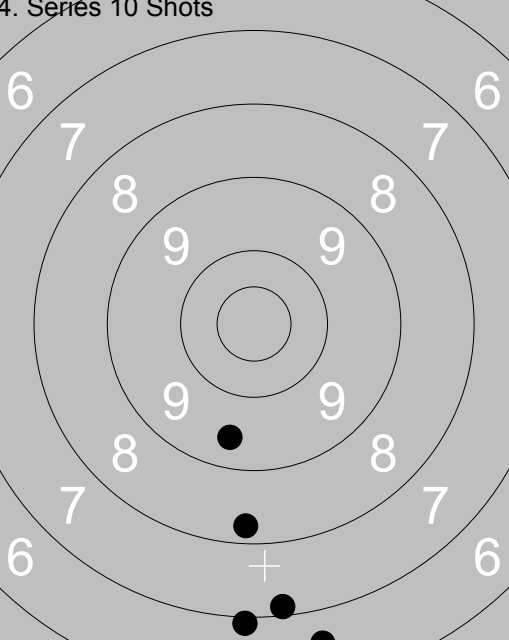
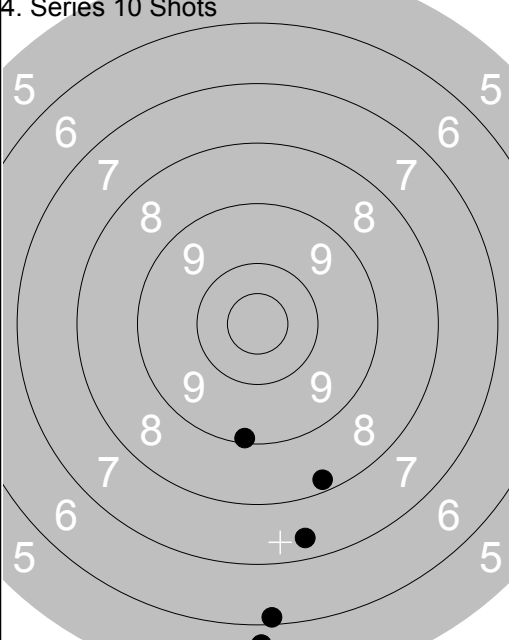
<p>4. Series 10 Shots</p> 	<p>1: 7.1 ↓ 2: 9.5 ↓ 3: 8.3 ↓ 4: 6.6 ↓ 5: 6.9 ↓</p>	<p>4. Series 10 Shots</p> 		<p>6: 9.1 ↓ 7: 8.2 ↓ 8: 6.1 ↓ 9: 7.4 ↓ 10: 5.7 ↓</p>	
Series 36.0				Series 35.0	
Total 172.0				Total 207.0	

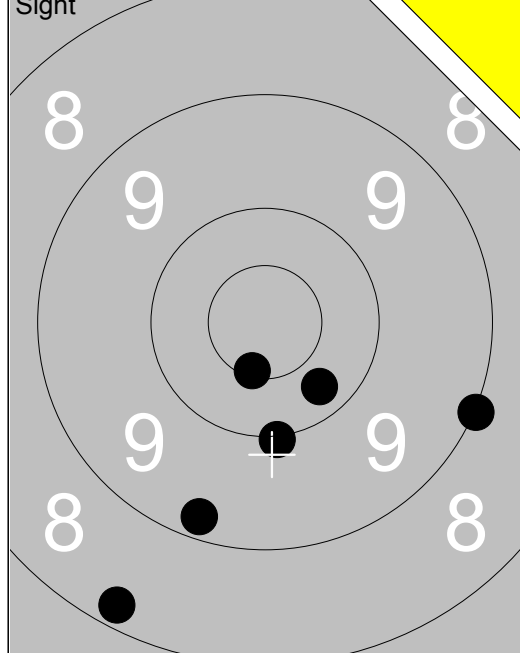

1:	9.0	→
2:	*10.5	↓
3:	10.3	↓
4:	10.0	↓
5:	9.2	↓
6:	8.2	↓
Series	56.0	
Total	0.0	

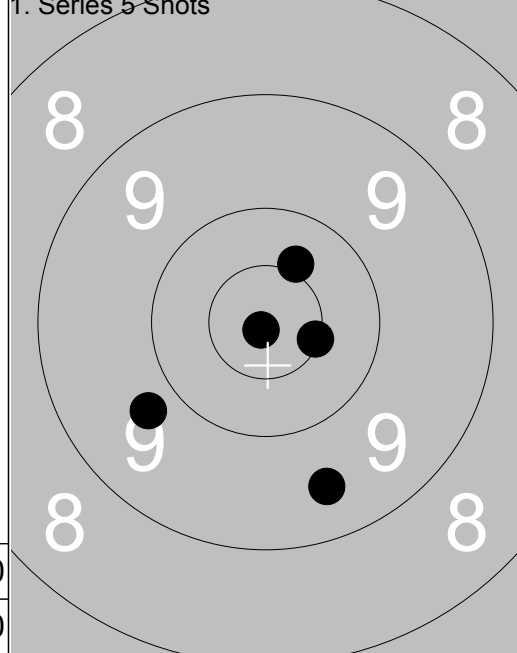

1:	*10.4	↗
2:	9.7	↙
3:	*10.5	→
4:	*10.9	↙
5:	9.5	↓
Series	48.0	
Total	48.0	

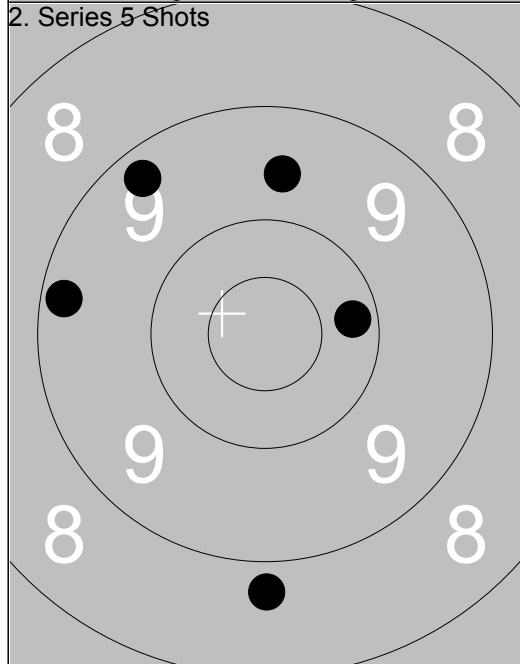

1:	9.6	↑
2:	9.2	←
3:	10.2	→
4:	8.8	↓
5:	9.3	↗
Series	45.0	
Total	93.0	

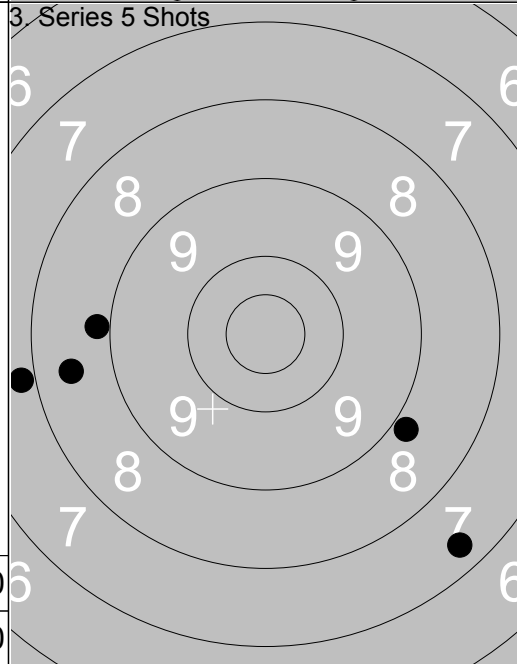

1:	7.4	↘
2:	8.9	←
3:	8.5	←
4:	8.9	↘
5:	7.8	←
Series	38.0	
Total	131.0	

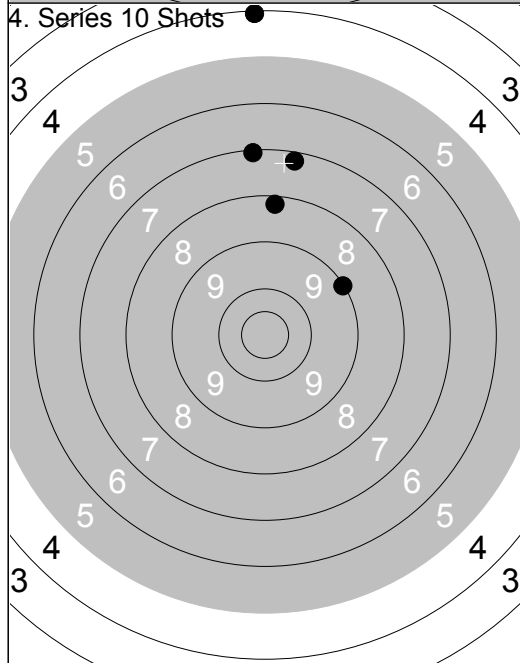

1:	7.1	↑
2:	9.0	↗
3:	7.2	↑
4:	4.1	↑
5:	8.2	↑
Series	35.0	
Total	166.0	

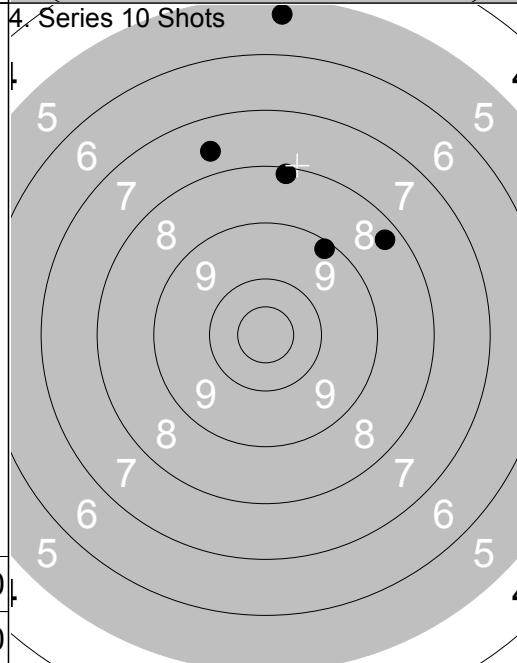

6:	7.6	↗
7:	8.1	↑
8:	8.3	↗
9:	9.2	↗
10:	5.3	↑
Series	37.0	
Total	203.0	

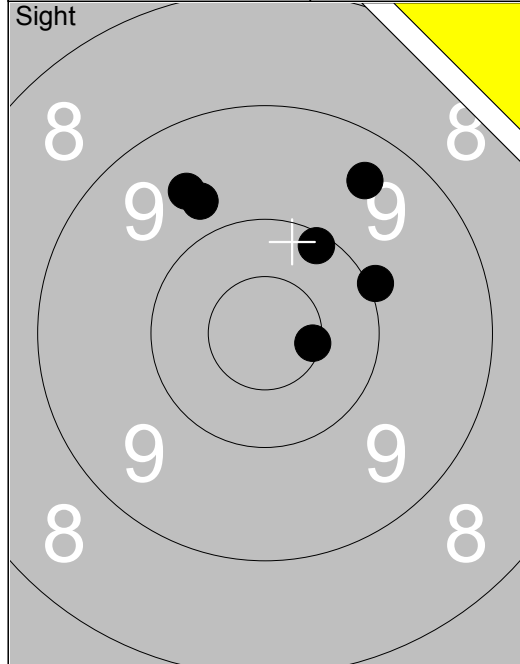

1: 10.1 ↗
2: *10.6 ⇒
3: 9.6 ↖
4: 9.7 ↖
5: 9.4 ↗
6: 10.0 ⇒
Series 57.0
Total 0.0

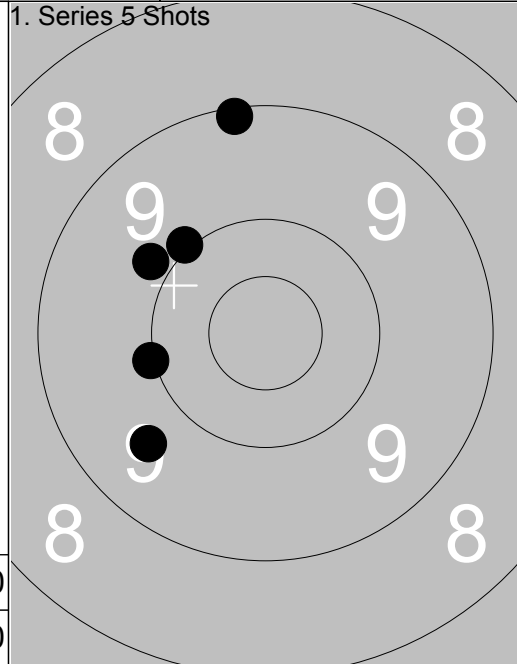

1: 9.1 ↗
2: 9.8 ↖
3: 10.0 ↖
4: 9.6 ↘
5: 10.0 ←
Series 47.0
Total 47.0

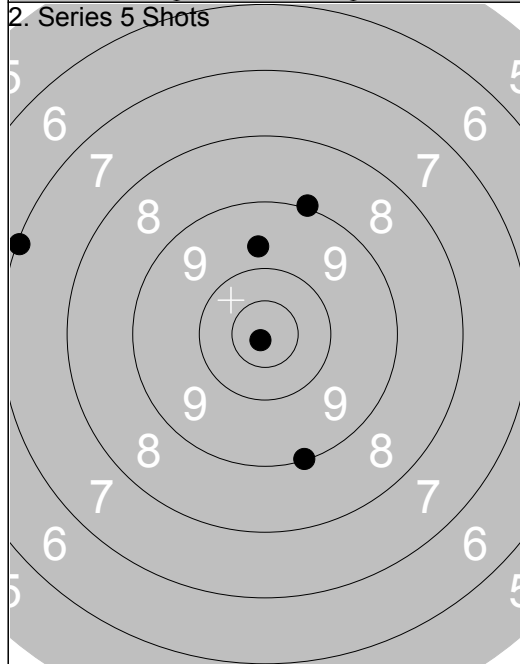

1: 9.7 ↗
2: 7.1 ←
3: *10.8 ↘
4: 9.0 ↗
5: 9.0 ↘
Series 44.0
Total 91.0

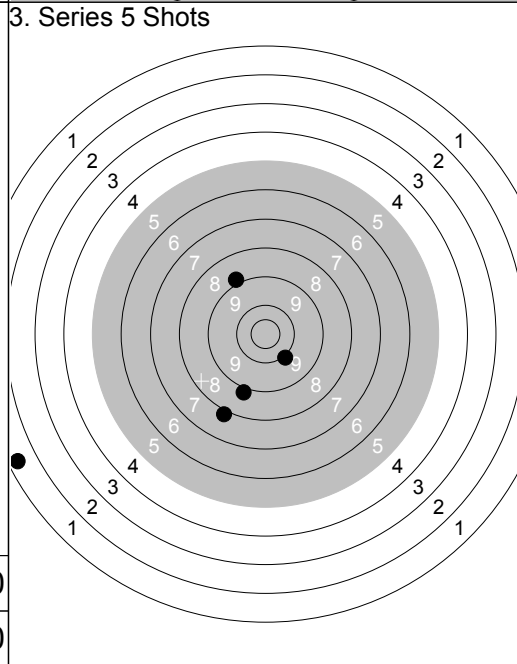

1: 8.9 ↘
2: 10.0 ↘
3: 7.9 ↘
4: 8.9 ↖
5: 1.4 ←
Series 34.0
Total 125.0

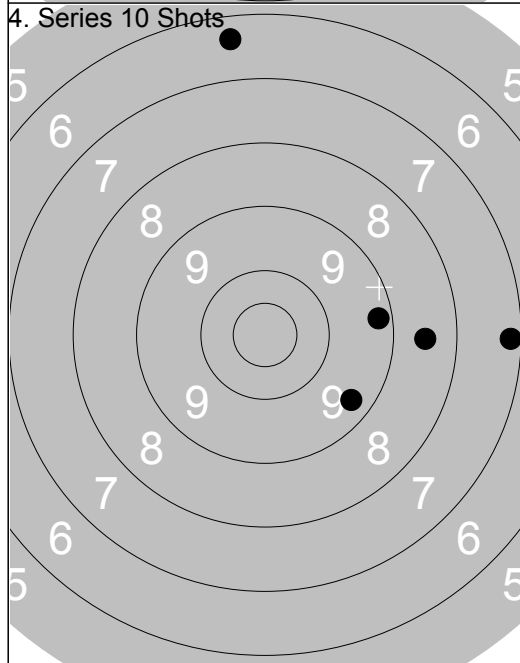

1: 6.4 ↗
2: 8.5 ⇒
3: 9.3 ↘
4: 9.2 ⇒
5: 7.2 ⇒
Series 39.0
Total 164.0

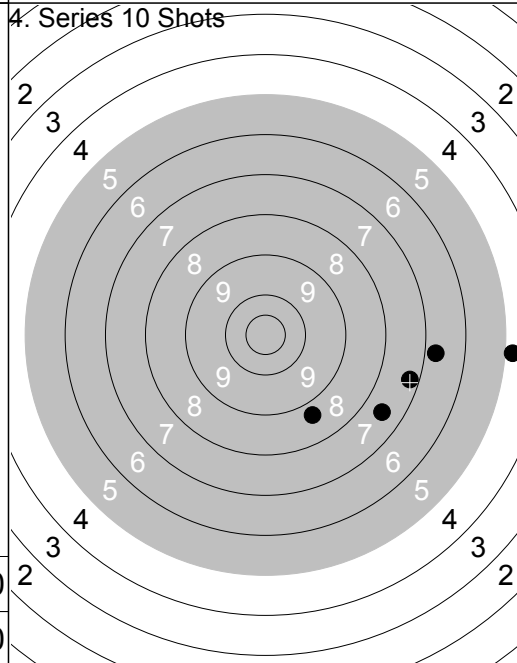

6: 7.5 ↘
7: 7.3 ⇒
8: 6.8 ⇒
9: 4.8 ⇒
10: 8.7 ↘
Series 32.0
Total 196.0

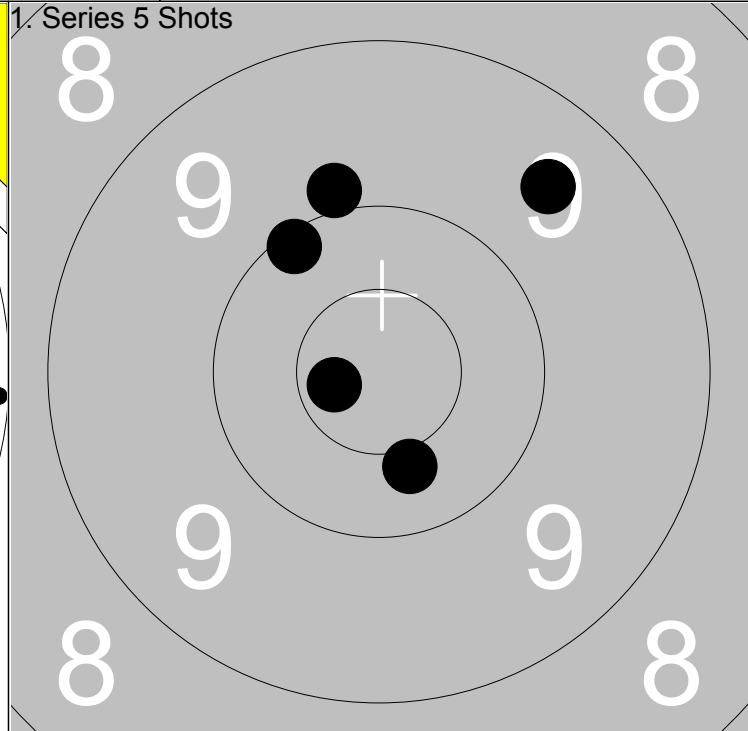
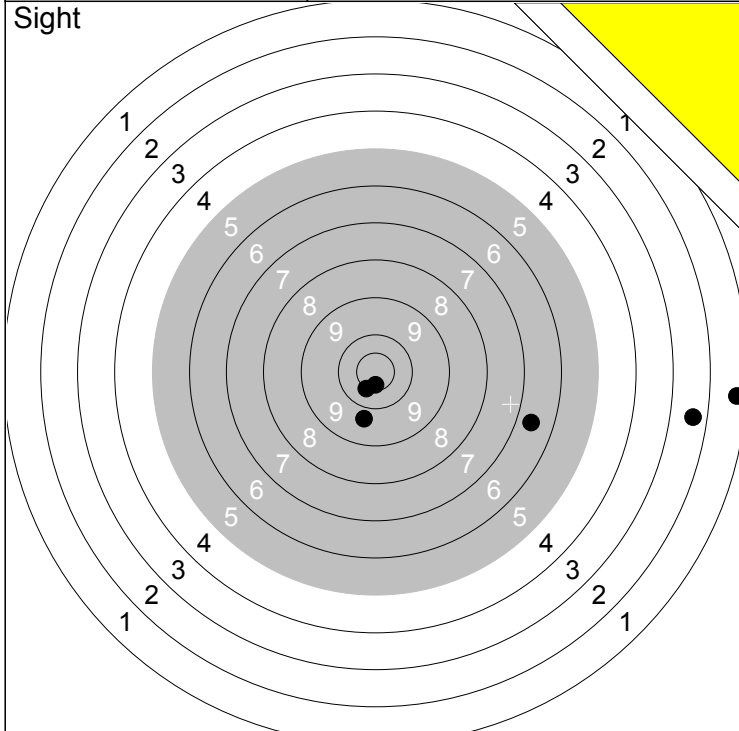

1: 1.3 →	6: *10.5 ↘	Series	38.0
2: 2.4 →		Total	0.0
3: 6.6 →			
4: *10.6 ↓			
5: 9.7 ↓			

1: 10.1 ↖	Series	48.0
2: *10.7 ←	Total	48.0
3: 9.9 ↑		
4: 9.5 ↗		
5: 10.4 ↓		

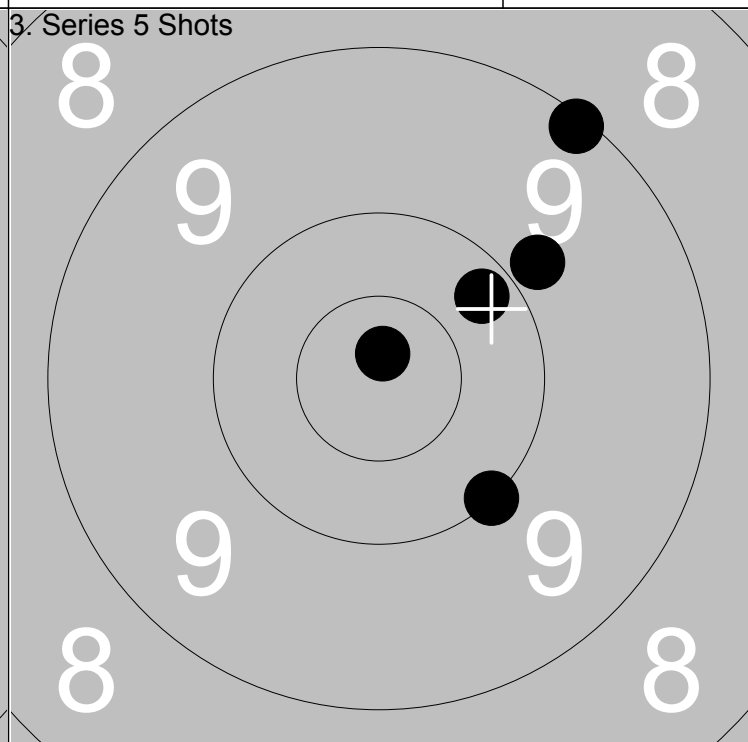
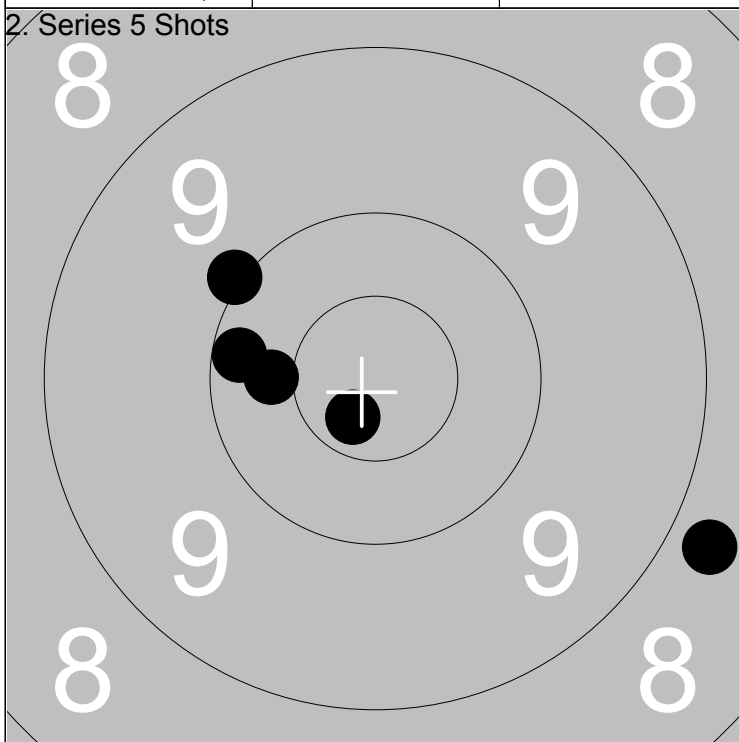

1: *10.7 ↘	Series	48.0
2: 10.2 ←	Total	96.0
3: 10.0 ↖		
4: 10.4 ←		
5: 8.8 →		

1: 9.8 ↗	Series	48.0
2: *10.8 ↑	Total	144.0
3: 10.0 ↘		
4: 9.1 ↗		
5: 10.2 ↗		

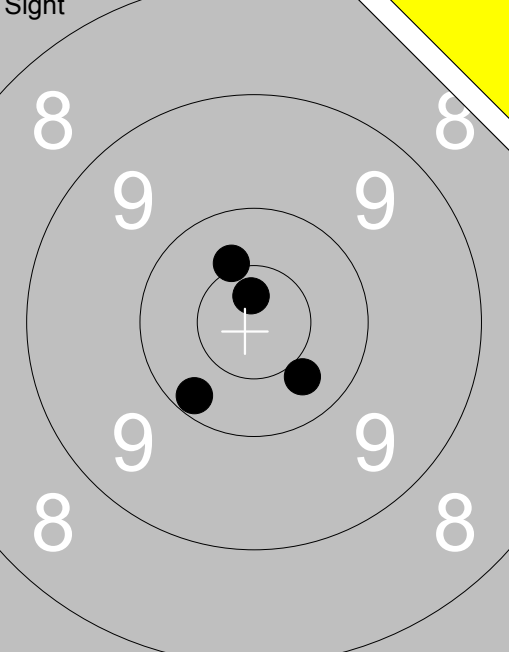
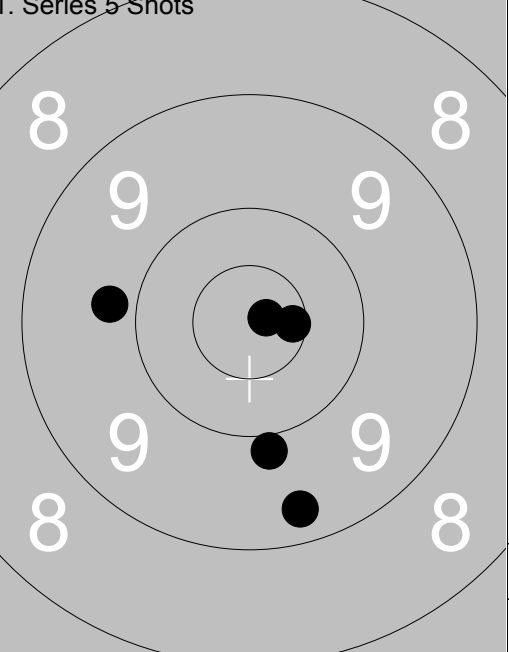
 <p>Sight</p>	<p>1: *10.4 ↖</p> <p>2: *10.7 ↑</p> <p>3: 10.2 ↘</p> <p>4: 10.4 ↘</p>	<p>1. Series 5 Shots</p> 	<p>1: 9.8 ←</p> <p>2: *10.6 →</p> <p>3: 9.9 ↓</p> <p>4: 9.3 ↓</p> <p>5: *10.8 →</p>
Series 40.0		Series 47.0	
Total 0.0		Total 47.0	

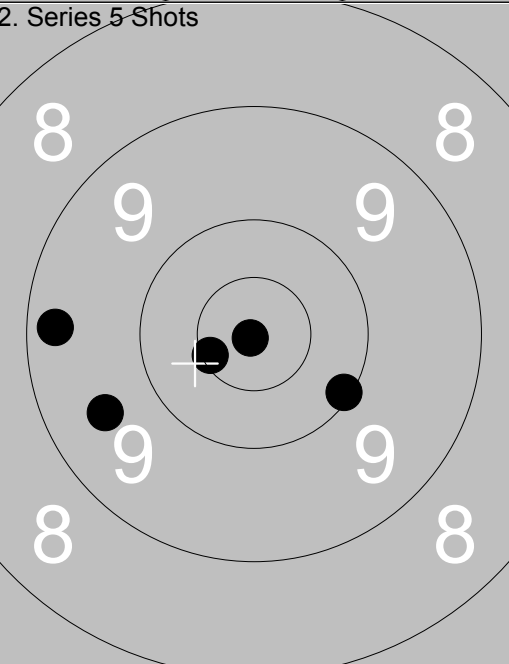
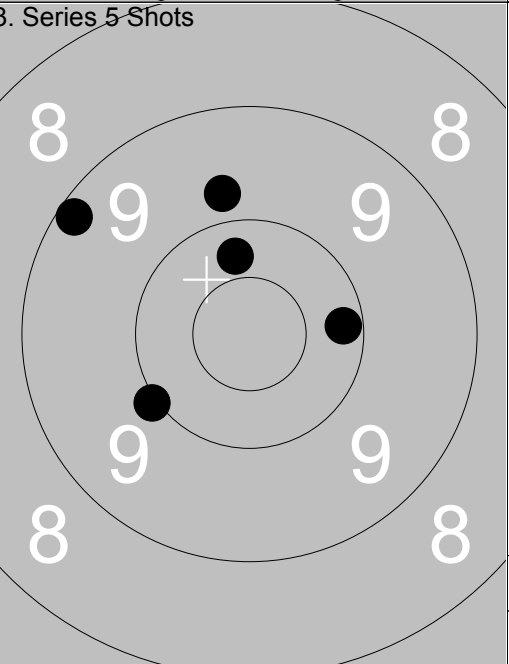
<p>2. Series 5 Shots</p> 	<p>1: 9.5 ←</p> <p>2: 9.3 ←</p> <p>3: 10.1 ↘</p> <p>4: *10.6 ↘</p> <p>5: *10.9 ↘</p>	<p>3. Series 5 Shots</p> 	<p>1: 10.2 →</p> <p>2: 10.3 ↑</p> <p>3: 9.2 ↘</p> <p>4: 9.8 ↑</p> <p>5: 10.0 ↘</p>
Series 48.0		Series 48.0	
Total 95.0		Total 143.0	

<p>4. Series 10 Shots</p> 	<p>1: 6.6 →</p> <p>2: 6.9 →</p> <p>3: 8.8 ↑</p> <p>4: 9.6 ↑</p> <p>5: 8.8 →</p>	<p>4. Series 10 Shots</p> 	<p>6: 8.5 ↑</p> <p>7: 8.5 ↑</p> <p>8: 9.7 ↑</p> <p>9: 6.6 ↑</p> <p>10: 6.8 ↑</p>
Series 37.0		Series 37.0	
Total 180.0		Total 217.0	

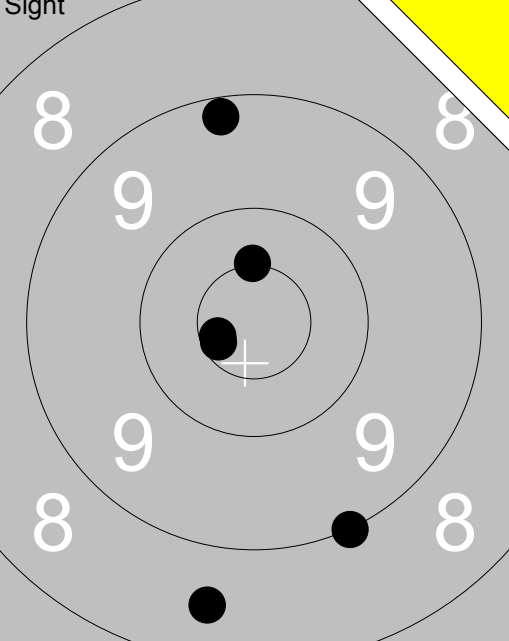
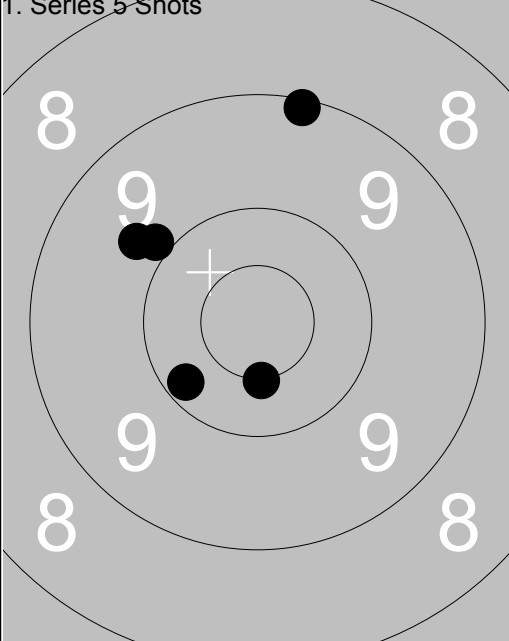
<p>Sight</p>  <p>Target diagram showing 5 shots. Scores: 1: *10.5↑, 2: 9.2↑, 3: 8.5↓, 4: *10.6↙, 5: *10.6↙, 6: 9.0↓. A yellow triangle is in the top right corner.</p>	<p>1. Series 5 Shots</p>  <p>Target diagram showing 5 shots. Scores: 1: 9.1↑, 2: 9.8↖, 3: 9.9↖, 4: 10.2↙, 5: *10.5↓.</p>	<table border="1" style="width:100%; border-collapse: collapse;"> <tr> <td style="text-align: right;">Series</td> <td style="text-align: left;">56.0</td> </tr> <tr> <td style="text-align: right;">Total</td> <td style="text-align: left;">0.0</td> </tr> </table>	Series	56.0	Total	0.0	<table border="1" style="width:100%; border-collapse: collapse;"> <tr> <td style="text-align: right;">Series</td> <td style="text-align: left;">47.0</td> </tr> <tr> <td style="text-align: right;">Total</td> <td style="text-align: left;">47.0</td> </tr> </table>	Series	47.0	Total	47.0
Series	56.0										
Total	0.0										
Series	47.0										
Total	47.0										

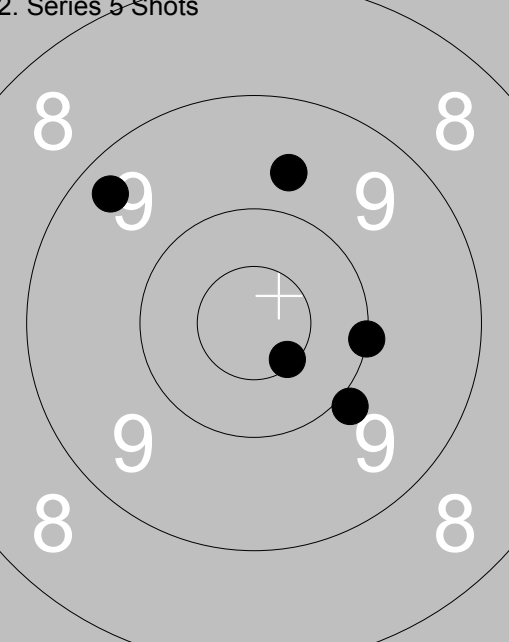
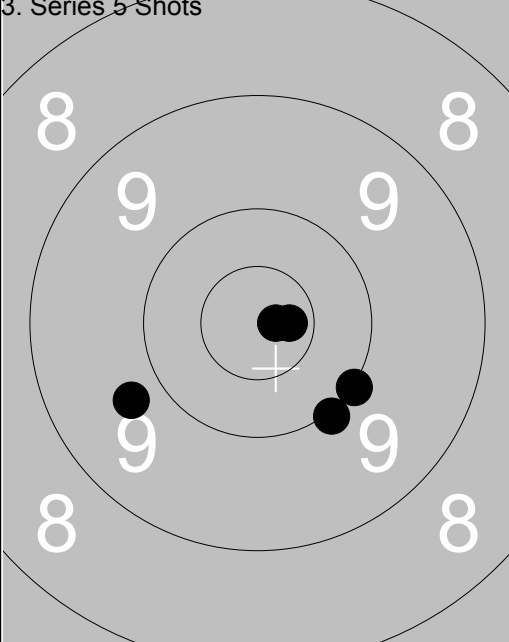
<p>2. Series 5 Shots</p>  <p>Target diagram showing 5 shots. Scores: 1: 9.3↖, 2: 9.7↑, 3: 10.0→, 4: *10.5↘, 5: 9.9↘.</p>	<p>3. Series 5 Shots</p>  <p>Target diagram showing 5 shots. Scores: 1: *10.8→, 2: 10.0↘, 3: 10.0↘, 4: *10.7→, 5: 9.7↙.</p>	<table border="1" style="width:100%; border-collapse: collapse;"> <tr> <td style="text-align: right;">Series</td> <td style="text-align: left;">47.0</td> </tr> <tr> <td style="text-align: right;">Total</td> <td style="text-align: left;">94.0</td> </tr> </table>	Series	47.0	Total	94.0	<table border="1" style="width:100%; border-collapse: collapse;"> <tr> <td style="text-align: right;">Series</td> <td style="text-align: left;">49.0</td> </tr> <tr> <td style="text-align: right;">Total</td> <td style="text-align: left;">143.0</td> </tr> </table>	Series	49.0	Total	143.0
Series	47.0										
Total	94.0										
Series	49.0										
Total	143.0										

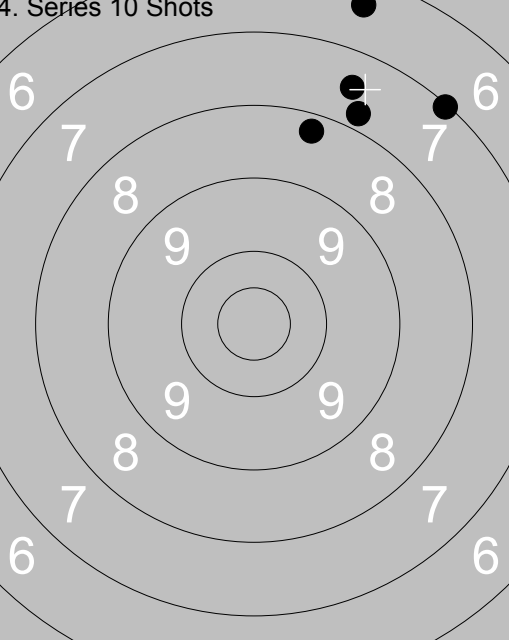
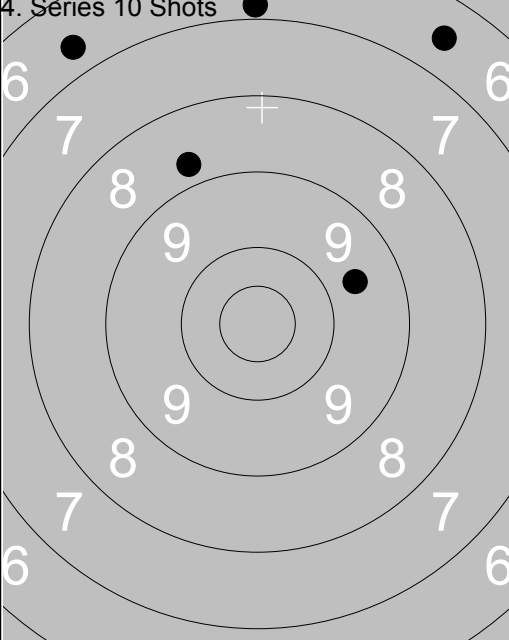
<p>4. Series 10 Shots</p>  <p>Target diagram showing 10 shots. Scores: 1: 7.8↑, 2: 6.4↑, 3: 7.1↗, 4: 7.5↑, 5: 8.3↑.</p>	<p>4. Series 10 Shots</p>  <p>Target diagram showing 10 shots. Scores: 6: 9.6↗, 7: 6.7↖, 8: 6.5↗, 9: 8.7↖, 10: 6.8↑.</p>	<table border="1" style="width:100%; border-collapse: collapse;"> <tr> <td style="text-align: right;">Series</td> <td style="text-align: left;">35.0</td> </tr> <tr> <td style="text-align: right;">Total</td> <td style="text-align: left;">178.0</td> </tr> </table>	Series	35.0	Total	178.0	<table border="1" style="width:100%; border-collapse: collapse;"> <tr> <td style="text-align: right;">Series</td> <td style="text-align: left;">35.0</td> </tr> <tr> <td style="text-align: right;">Total</td> <td style="text-align: left;">213.0</td> </tr> </table>	Series	35.0	Total	213.0
Series	35.0										
Total	178.0										
Series	35.0										
Total	213.0										

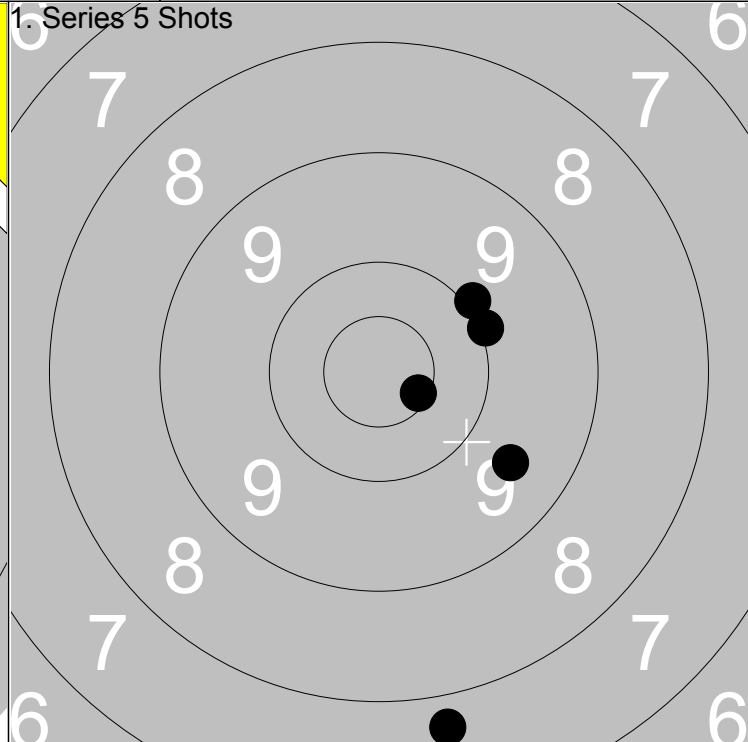
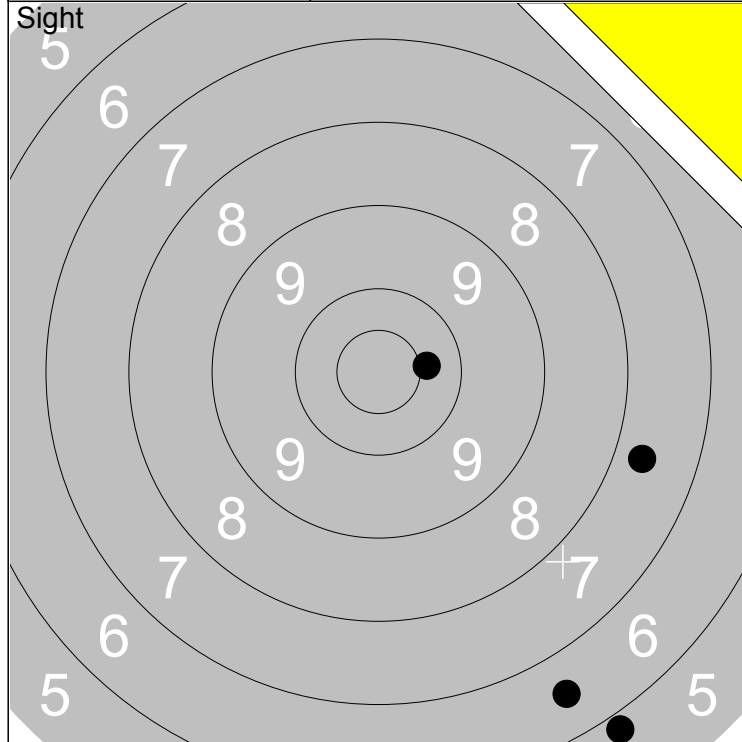

1: 10.4 →
2: 7.7 →
3: 6.5 ↓
4: 5.8 ↓

Series	28.0
Total	0.0

1: 7.7 ↓
2: 10.0 →
3: 10.0 ↗
4: *10.6 ↘
5: 9.6 ↓

Series	46.0
Total	46.0

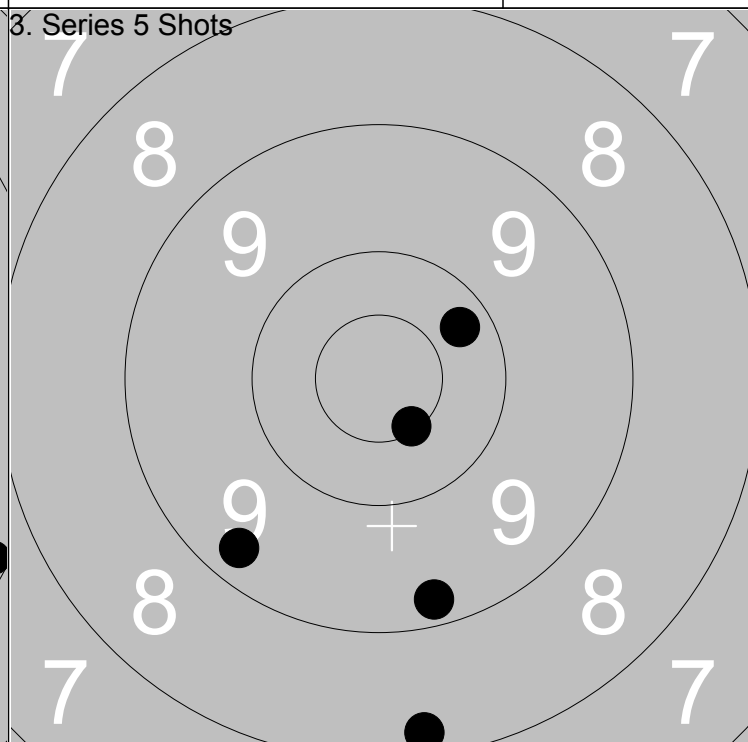
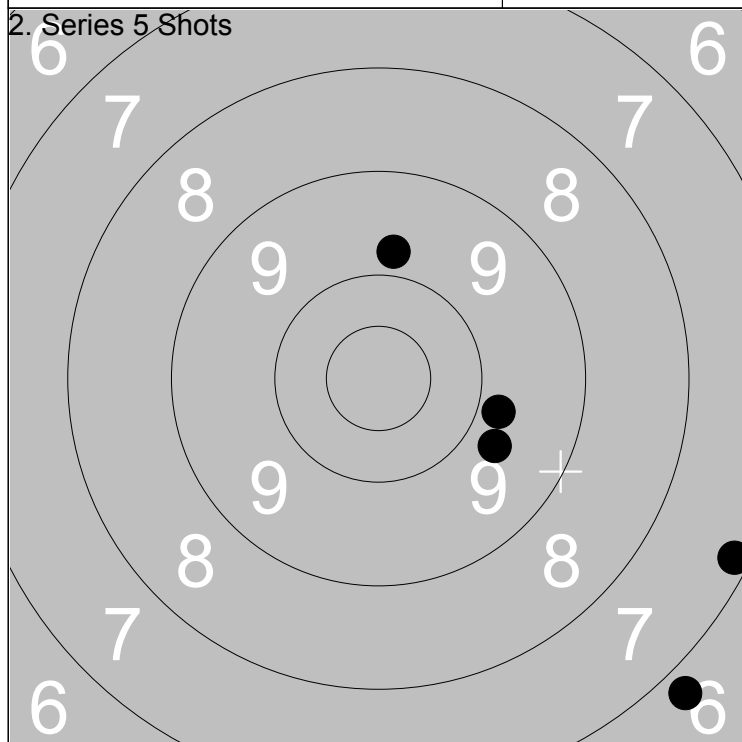

1: 9.8 ↑
2: 9.8 →
3: 9.7 ↓
4: 6.8 ↓
5: 7.2 ↓

Series	40.0
Total	86.0

1: *10.5 ↓
2: 9.3 ↓
3: 8.2 ↓
4: 9.2 ↓
5: 10.3 ↗

Series	46.0
Total	132.0



<p>Sight</p>	<p>1. Series 5 Shots</p>	<p>1: 8.9 ↗</p> <p>2: *10.5 ↘</p> <p>3: *10.8 →</p> <p>4: 9.7 ↓</p> <p>5: 9.7 →</p> <p>6: 9.0 ↘</p>	<p>1: 10.1 ←</p> <p>2: 10.3 ↘</p> <p>3: 9.1 ↓</p> <p>4: 10.2 ↓</p> <p>5: 10.3 ↓</p>
Series 55.0	Series 49.0		
Total 0.0	Total 49.0		

<p>2. Series 5 Shots</p>	<p>3. Series 5 Shots</p>	<p>1: 8.0 ↖</p> <p>2: 9.7 ↓</p> <p>3: 9.7 ↗</p> <p>4: *10.4 ←</p> <p>5: 9.9 ↖</p>	<p>1: 7.8 ←</p> <p>2: 8.1 →</p> <p>3: 9.7 ↗</p> <p>4: 9.4 ←</p> <p>5: 9.4 →</p>
Series 45.0	Series 42.0		
Total 94.0	Total 136.0		

<p>4. Series 10 Shots</p>	<p>4. Series 10 Shots</p>	<p>1: 6.3 →</p> <p>2: 7.9 →</p> <p>3: 7.8 →</p> <p>4: 7.5 →</p> <p>5: 7.9 →</p>	<p>6: 6.8 ↗</p> <p>7: 8.0 →</p> <p>8: 9.6 ↗</p> <p>9: 7.7 →</p> <p>10: 9.5 →</p>
Series 34.0	Series 39.0		
Total 170.0	Total 209.0		

Relay <b>3</b>	Lane <b>5</b>	<b>Jan Wallerström</b>	
-------------------	------------------	------------------------	--

300m	Ununge	B	St
------	--------	---	----

07.07.2014	Tavelträffen B 2014	Ramselefors SKF
------------	---------------------	-----------------

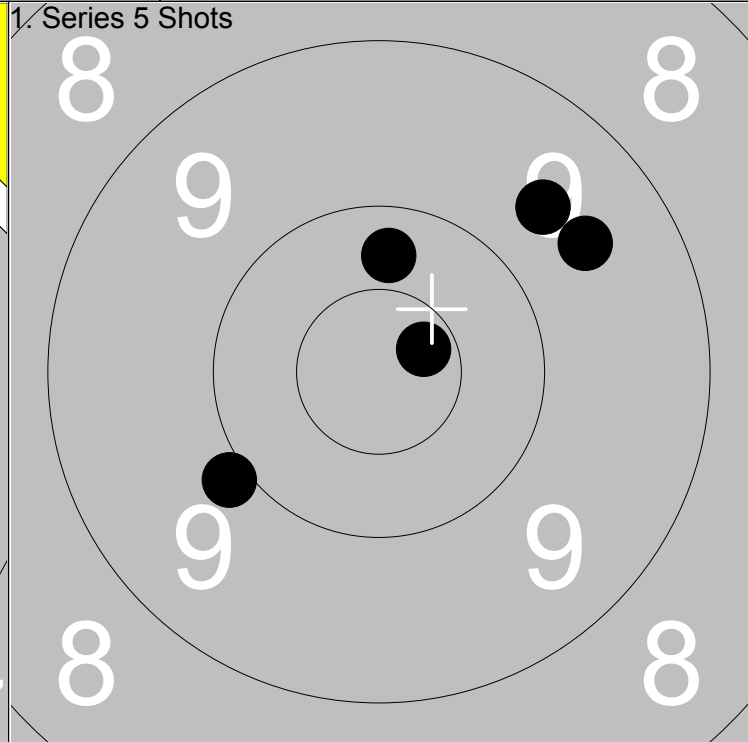
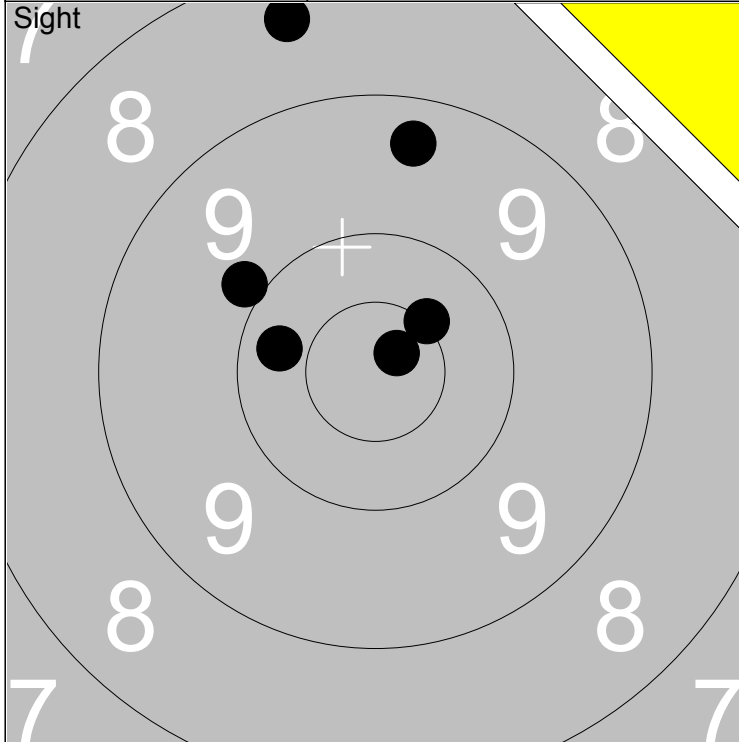

1: 9.9 ↙	6: *10.5 ↗	Series 56.0
2: 10.3 ↙		
3: *10.8 ↗		Total 0.0
4: 9.4 ↑		
5: 8.4 ↑		

1: 10.3 ↑	Series 47.0
2: 9.9 ↙	
3: 9.6 ↗	Total 47.0
4: 9.6 ↗	
5: *10.7 ↗	

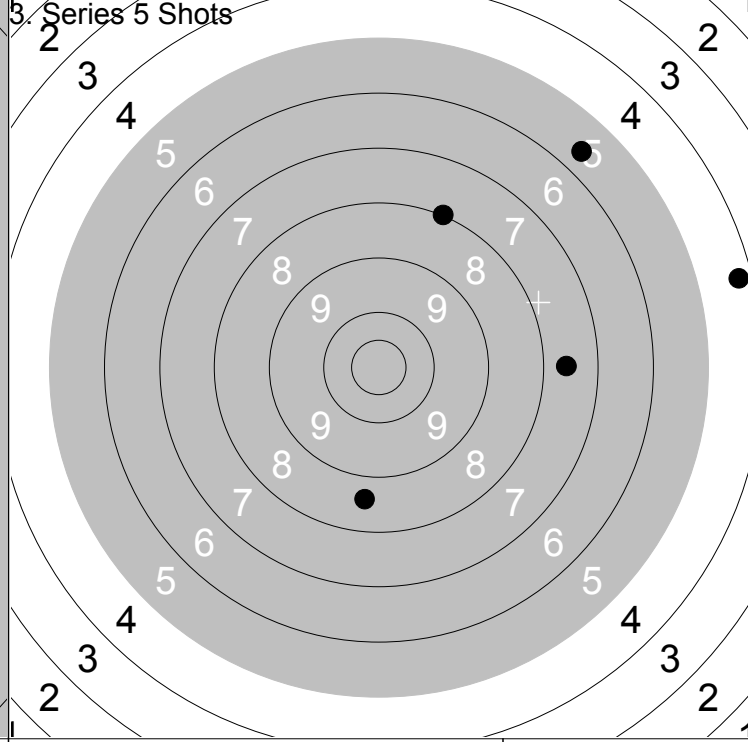
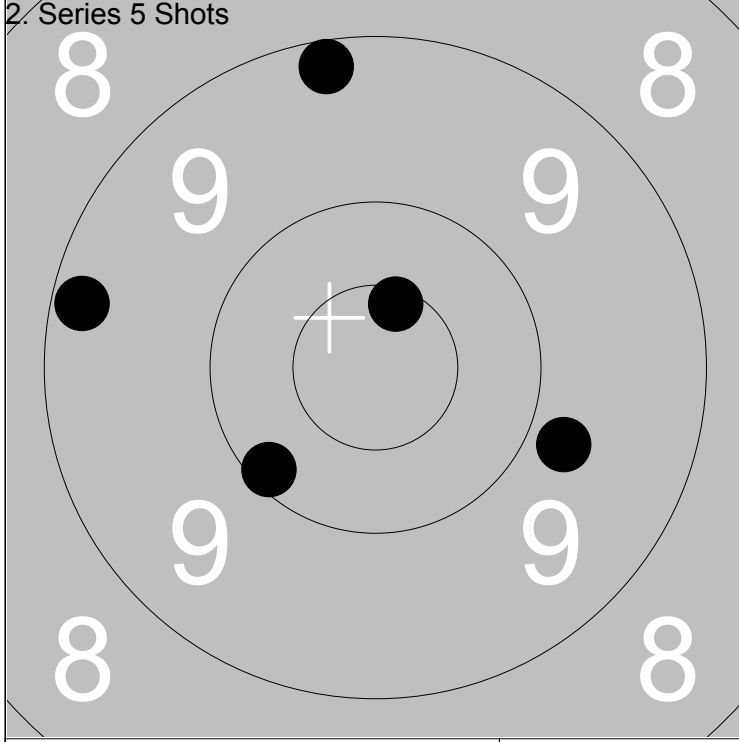

1: 9.2 ↑	Series 47.0
2: 9.8 →	
3: 10.1 ↙	Total 94.0
4: *10.6 ↑	
5: 9.2 ←	

1: 4.3 →	Series 32.0
2: 8.6 ↓	
3: 5.6 ↗	Total 126.0
4: 7.6 →	
5: 8.0 ↑	

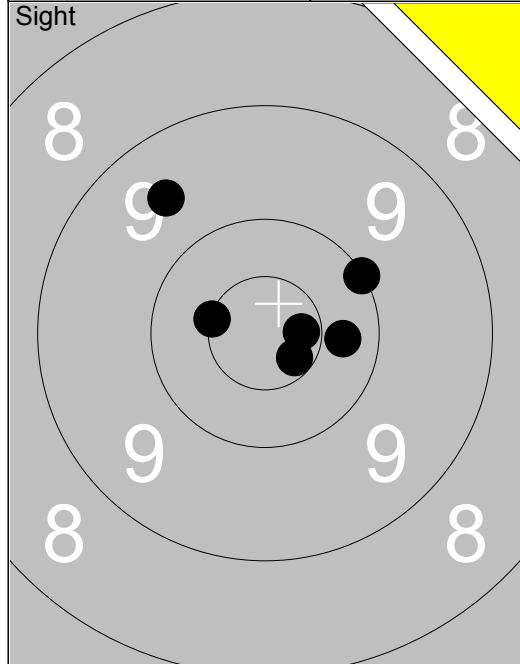

1:	*10.7	→
2:	10.0	↗
3:	10.3	→
4:	*10.6	↘
5:	9.6	↖
6:	*10.5	↖
Series		59.0
Total		0.0

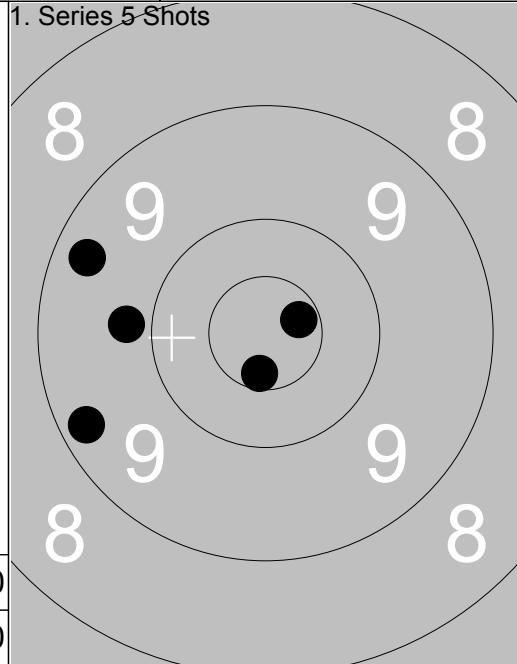

1:	*10.6	↓
2:	9.8	←
3:	*10.7	↗
4:	9.3	↖
5:	9.3	↖
Series		47.0
Total		47.0

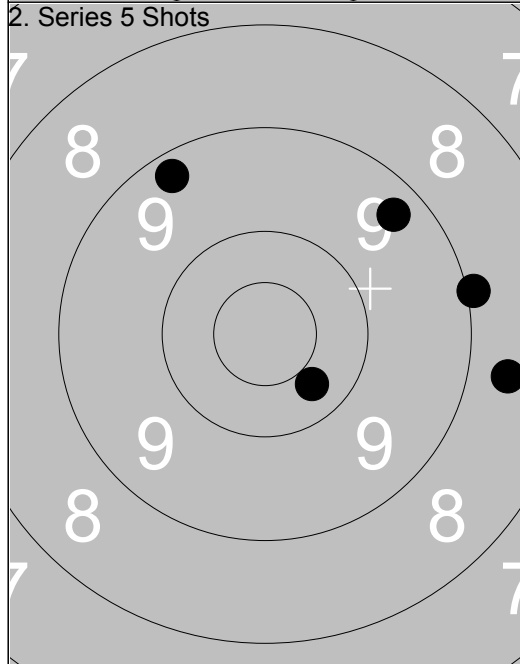

1:	10.3	↘
2:	8.6	→
3:	9.0	→
4:	9.3	↗
5:	9.3	↖
Series		45.0
Total		92.0

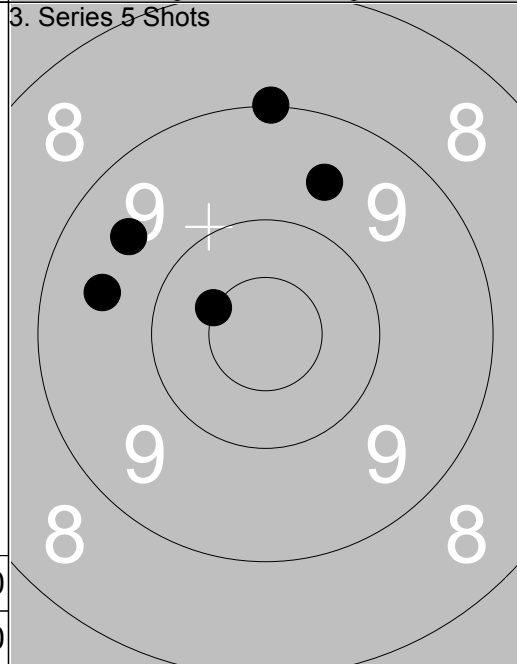

1:	9.6	↖
2:	*10.5	↖
3:	9.0	↑
4:	9.6	↗
5:	9.6	↖
Series		46.0
Total		138.0

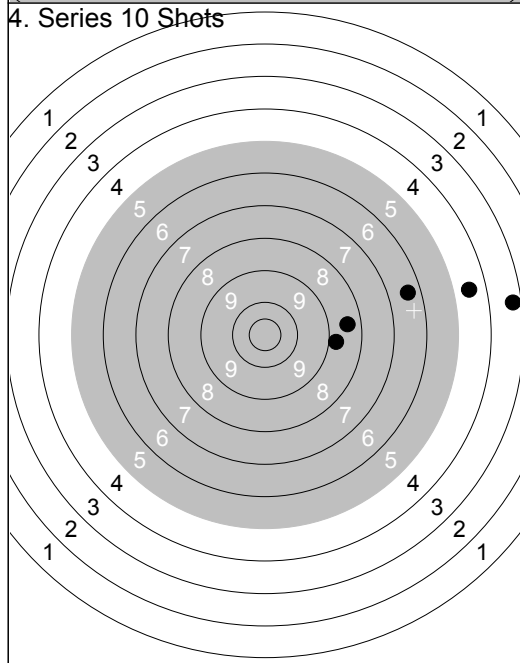

1:	8.5	→
2:	3.3	→
3:	4.6	→
4:	6.4	→
5:	8.8	→
Series		29.0
Total		167.0

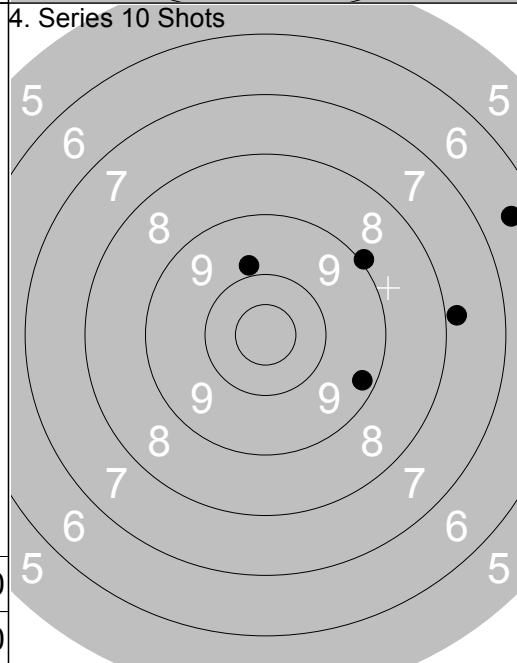

6:	9.0	↗
7:	9.3	→
8:	7.8	→
9:	6.5	↗
10:	9.8	↑
Series		40.0
Total		207.0

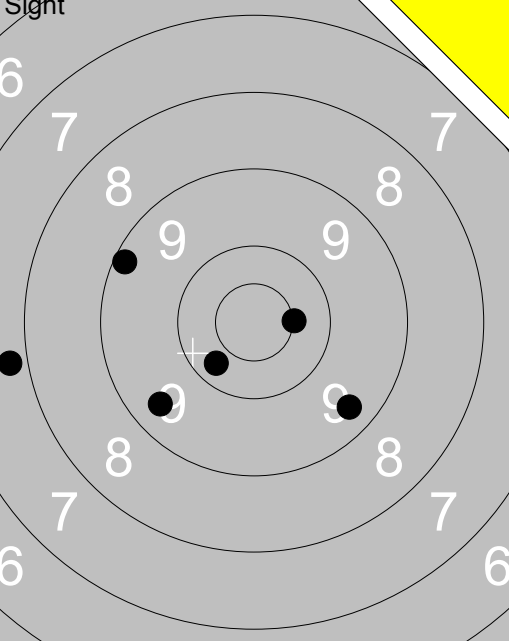
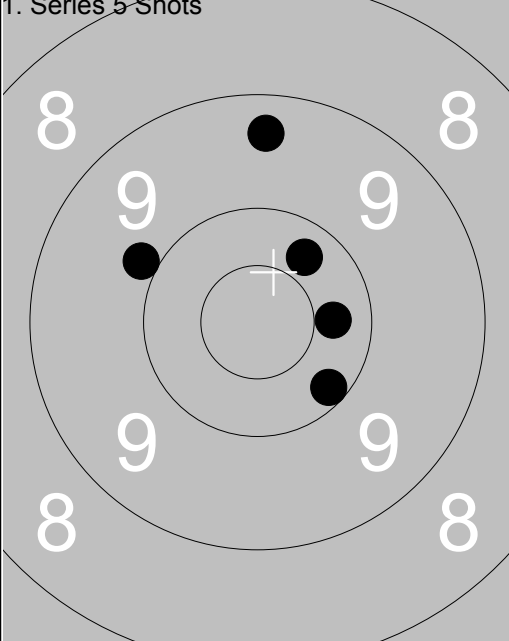
<p>Sight</p> 	<p>1: 9.2 ↙ 2: 9.4 ↘ 3: *10.5 → 4: 10.3 ↘ 5: 7.8 ← 6: 9.4 ↘</p>	<p>1. Series 5 Shots</p> 	<p>1: 9.4 ↑ 2: 9.9 ↙ 3: 10.3 → 4: 10.3 ↗ 5: 10.2 ↘</p>
Series 54.0		Series 48.0	
Total 0.0		Total 48.0	

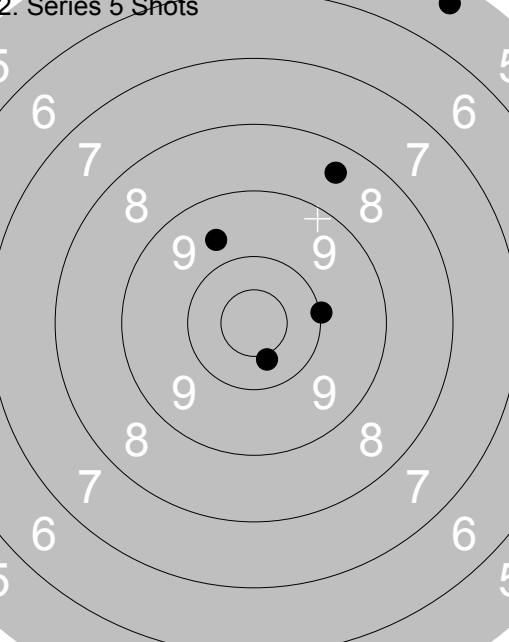
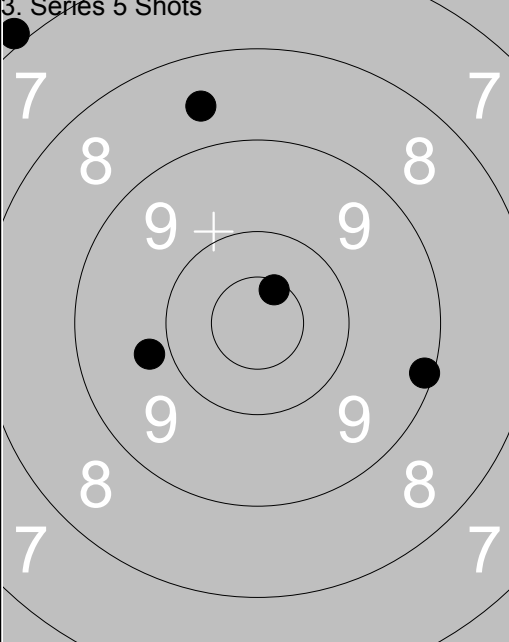
<p>2. Series 5 Shots</p> 	<p>1: 5.4 ↗ 2: 8.4 ↗ 3: 10.4 ↘ 4: 9.7 ↗ 5: 10.0 →</p>	<p>3. Series 5 Shots</p> 	<p>1: 8.6 ↑ 2: 9.8 ↙ 3: 9.1 → 4: 6.9 ↗ 5: *10.6 ↗</p>
Series 42.0		Series 42.0	
Total 90.0		Total 132.0	

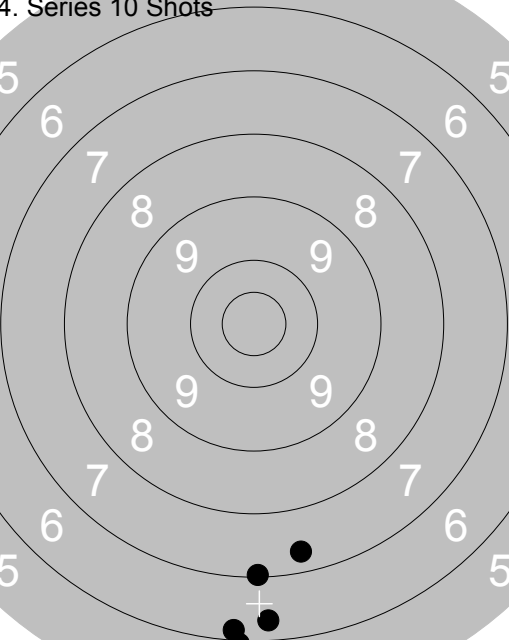
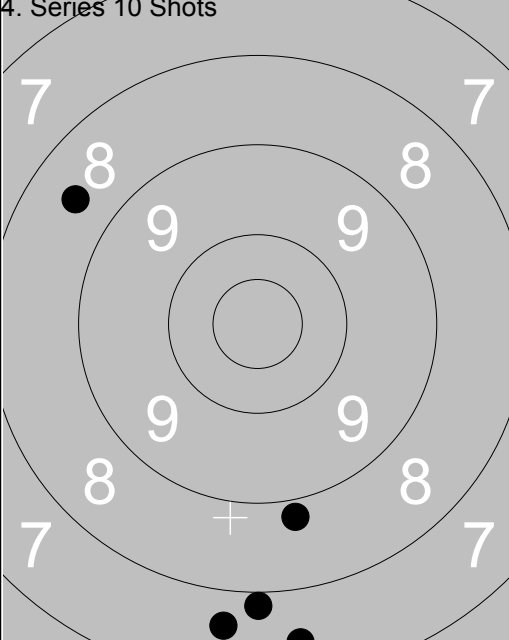
<p>4. Series 10 Shots</p> 	<p>1: 6.0 ↓ 2: 7.4 ↓ 3: 7.1 ↓ 4: 6.3 ↓ 5: 6.2 ↓</p>	<p>4. Series 10 Shots</p> 	<p>6: 8.6 ↙ 7: 7.9 ↓ 8: 8.8 ↓ 9: 7.4 ↓ 10: 7.6 ↓</p>
Series 32.0		Series 37.0	
Total 164.0		Total 201.0	

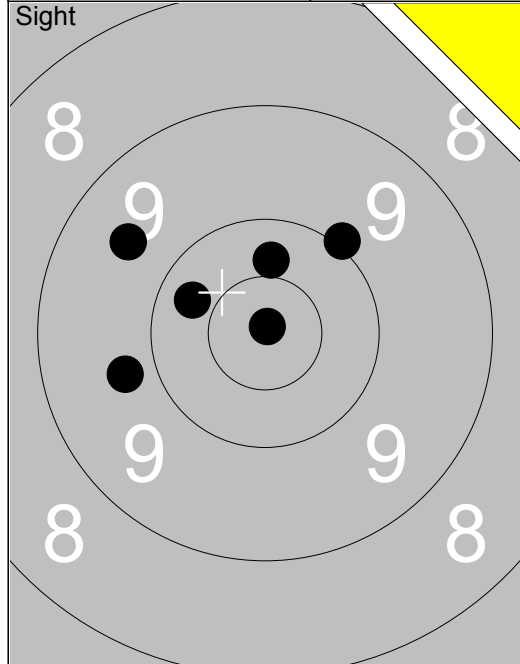

1:	10.3 ↙
2:	9.7 ←
3:	*10.9 ↗
4:	10.4 ↑
5:	10.0 ↗
6:	9.6 ↙
<b>Series 58.0</b>	
<b>Total 0.0</b>	

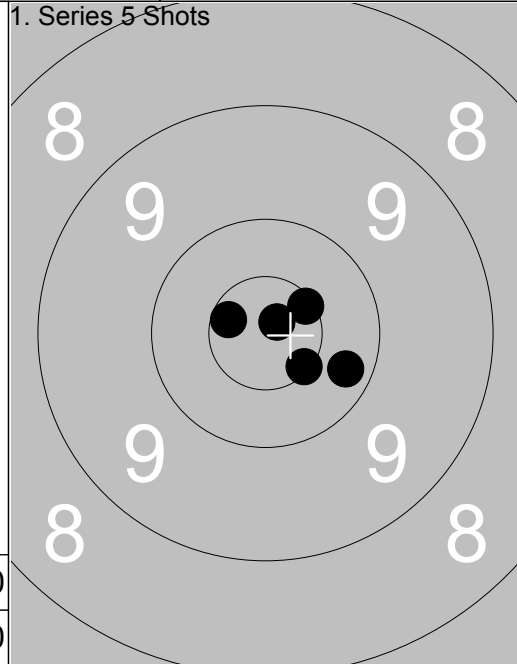

1:	*10.6 ↗
2:	*10.5 ↘
3:	*10.6 ↙
4:	*10.8 ↗
5:	10.2 ↘
<b>Series 50.0</b>	
<b>Total 50.0</b>	

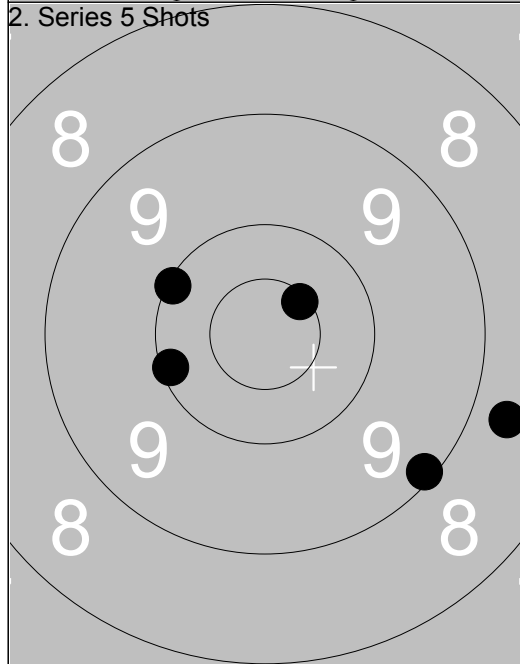

1:	8.7 →
2:	10.1 ↙
3:	10.1 ↙
4:	9.1 ↘
5:	*10.6 ↗
<b>Series 47.0</b>	
<b>Total 97.0</b>	

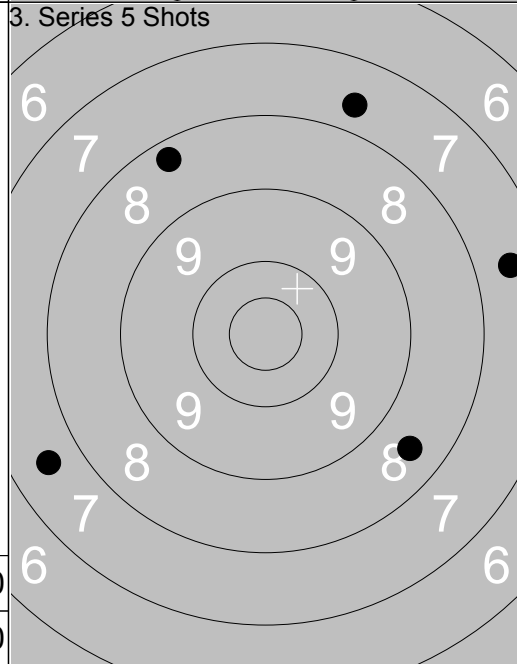

1:	7.7 ↗
2:	8.5 ↘
3:	8.3 ↗
4:	7.6 ←
5:	7.5 →
<b>Series 37.0</b>	
<b>Total 134.0</b>	

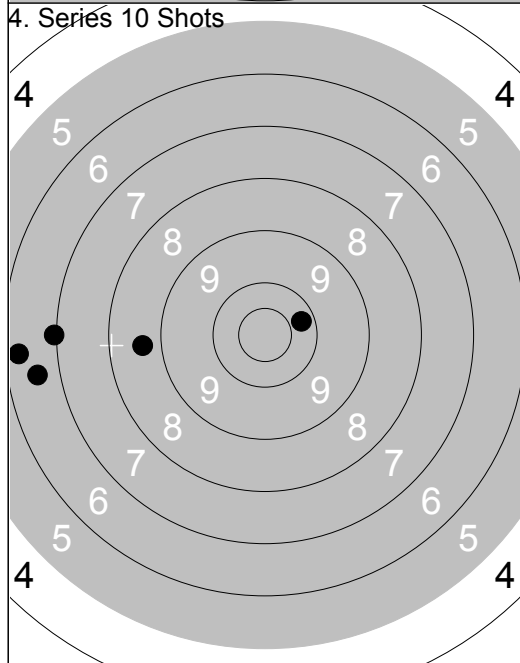

1:	10.3 →
2:	8.7 ←
3:	6.3 ←
4:	6.6 ←
5:	7.0 ←
<b>Series 37.0</b>	
<b>Total 171.0</b>	

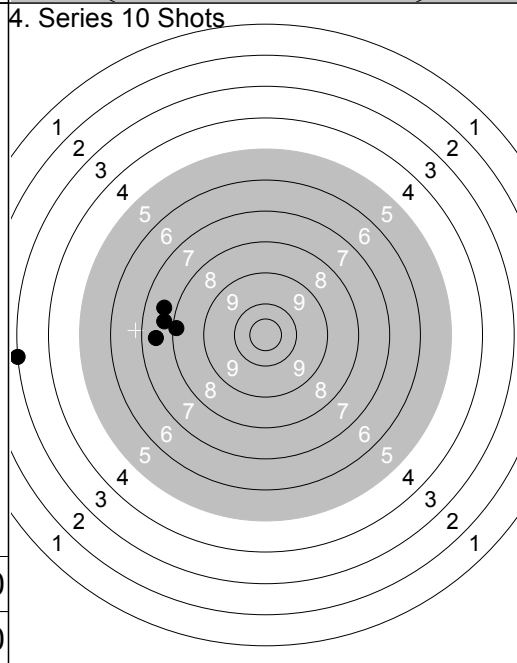

6:	7.5 ←
7:	7.7 ←
8:	8.1 ←
9:	7.6 ←
10:	3.0 ←
<b>Series 32.0</b>	
<b>Total 203.0</b>	

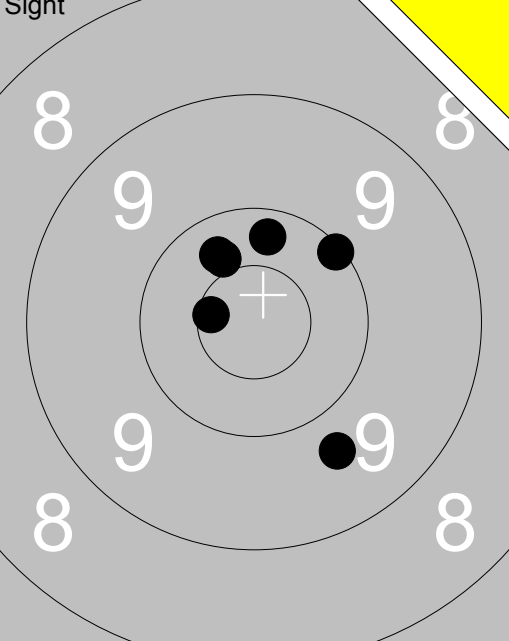
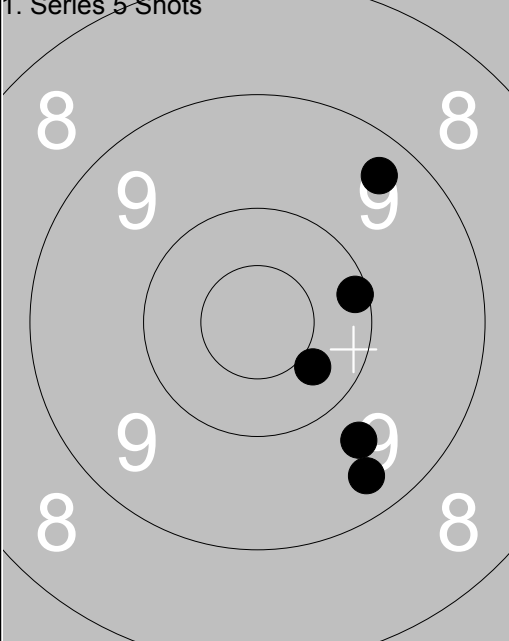
<p><b>Sight</b></p> 	<p>1: 10.1 ↗ 2: 9.7 ↓ 3: 10.4 ↖ 4: *10.6 ← 5: 10.2 ↑ 6: 10.3 ↖</p>	<p><b>1. Series 5 Shots</b></p> 	<p>1: 10.4 ↘ 2: 9.4 ↗ 3: 10.1 → 4: 9.4 ↓ 5: 9.7 ↓</p>
<p><b>Series</b> 59.0</p> <p><b>Total</b> 0.0</p>		<p><b>Series</b> 47.0</p> <p><b>Total</b> 47.0</p>	

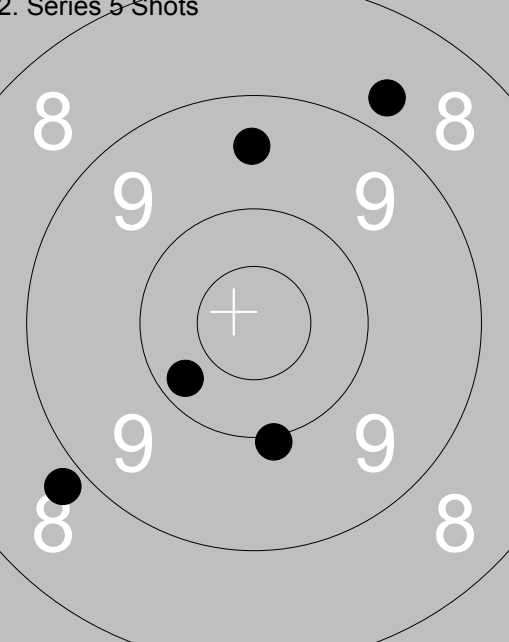
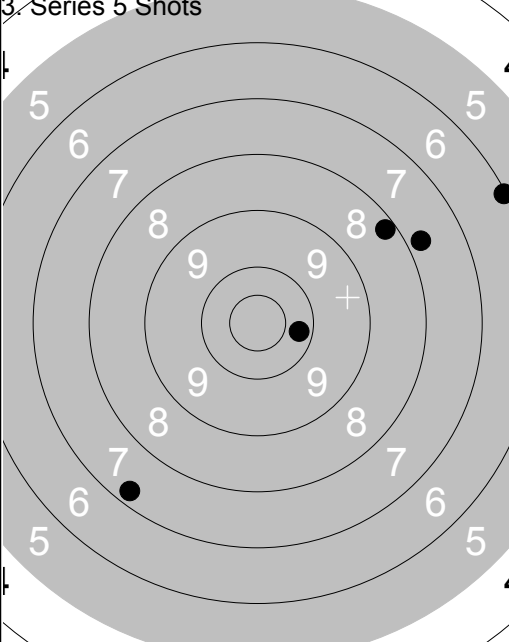
<p><b>2. Series 5 Shots</b></p> 	<p>1: 9.5 ↑ 2: 10.2 ↙ 3: 8.7 ↗ 4: 10.0 ↓ 5: 8.8 ↙</p>	<p><b>3. Series 5 Shots</b></p> 	<p>1: 7.8 ↗ 2: 6.1 ↗ 3: 7.3 ↓ 4: 10.2 → 5: 8.2 ↗</p>
<p><b>Series</b> 45.0</p> <p><b>Total</b> 92.0</p>		<p><b>Series</b> 38.0</p> <p><b>Total</b> 130.0</p>	

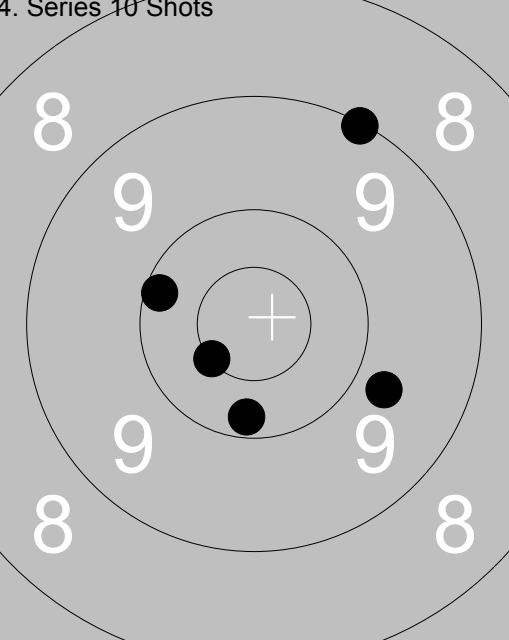
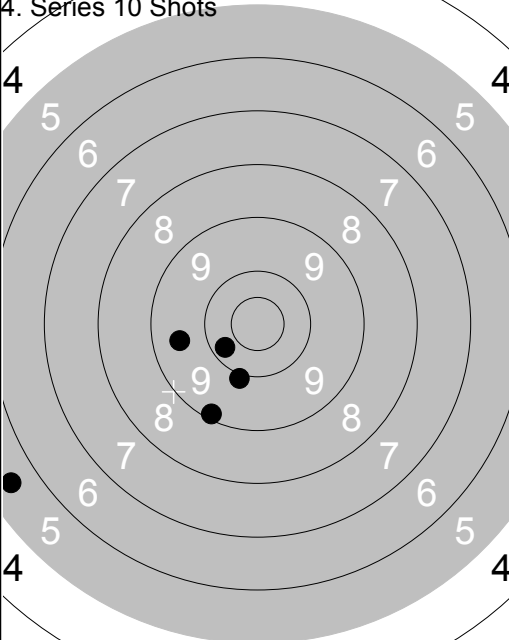
<p><b>4. Series 10 Shots</b></p> 	<p>1: 9.7 ↘ 2: 9.1 ↗ 3: 10.1 ← 4: 10.2 ↓ 5: *10.5 ↙</p>	<p><b>4. Series 10 Shots</b></p> 	<p>6: 10.3 ↙ 7: 9.5 ← 8: 5.5 ← 9: 9.1 ↓ 10: 9.9 ↓</p>
<p><b>Series</b> 48.0</p> <p><b>Total</b> 178.0</p>		<p><b>Series</b> 42.0</p> <p><b>Total</b> 220.0</p>	

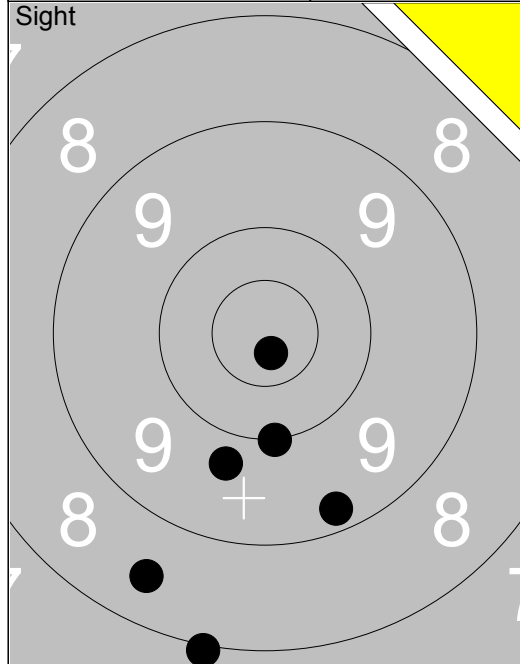

1: 10.0 ↓
2: 8.5 ↓
3: 9.7 ↓
4: *10.8 ↓
5: 8.0 ↓
6: 9.2 ↓
<b>Series 54.0</b>
<b>Total 0.0</b>

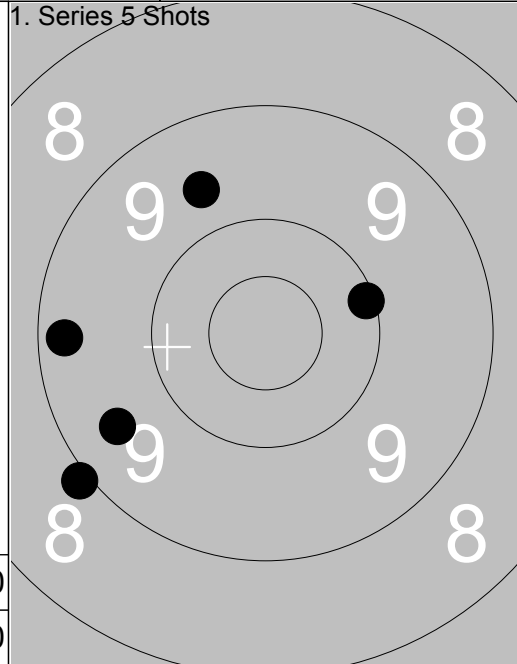

1: 8.9 ↙
2: 9.5 ↙
3: 9.3 ←
4: 9.6 ↗
5: 10.1 →
<b>Series 45.0</b>
<b>Total 45.0</b>

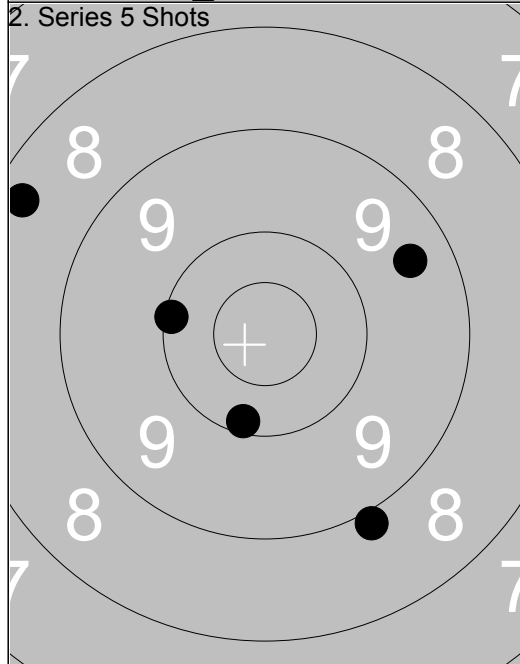

1: 10.1 ←
2: 10.1 ↓
3: 8.3 ↗
4: 8.9 ↓
5: 9.4 →
<b>Series 45.0</b>
<b>Total 90.0</b>

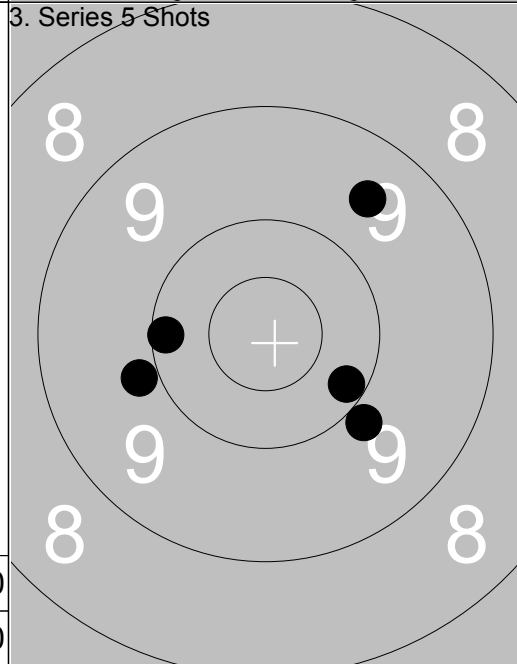

1: 9.9 ↙
2: 9.5 ↗
3: 10.2 ↘
4: 9.9 ↓
5: 10.1 ←
<b>Series 47.0</b>
<b>Total 137.0</b>

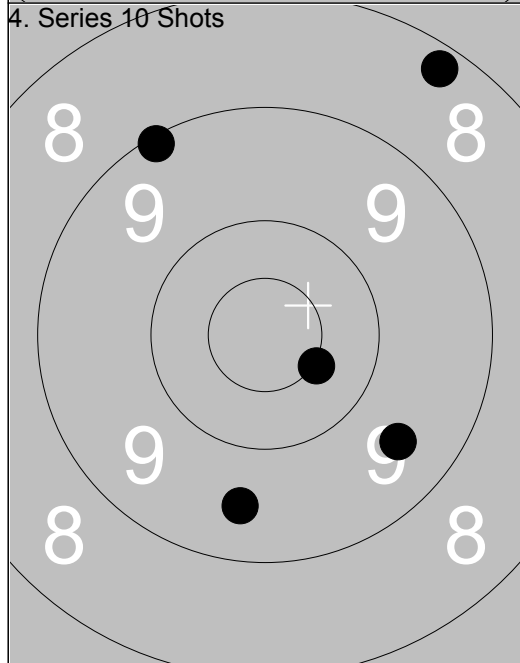

1: 9.5 ↘
2: *10.5 ↘
3: 9.1 ↗
4: 9.5 ↓
5: 8.2 ↗
<b>Series 45.0</b>
<b>Total 182.0</b>

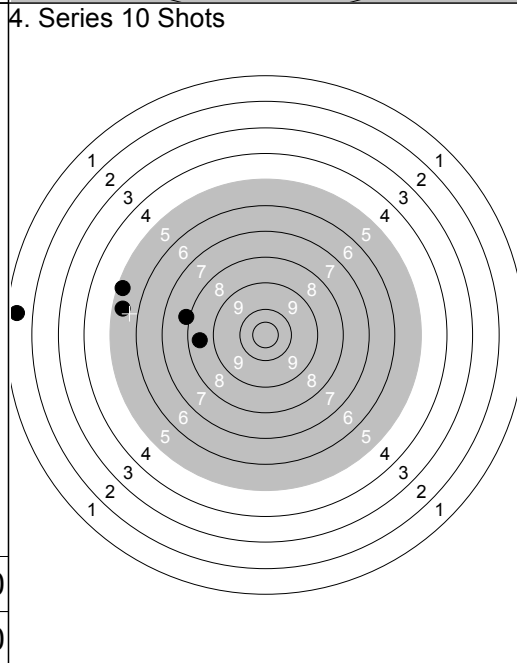

6: 8.5 ←
7: 5.4 ←
8: 7.9 ←
9: 5.2 ←
10: 1.4 ←
<b>Series 26.0</b>
<b>Total 208.0</b>

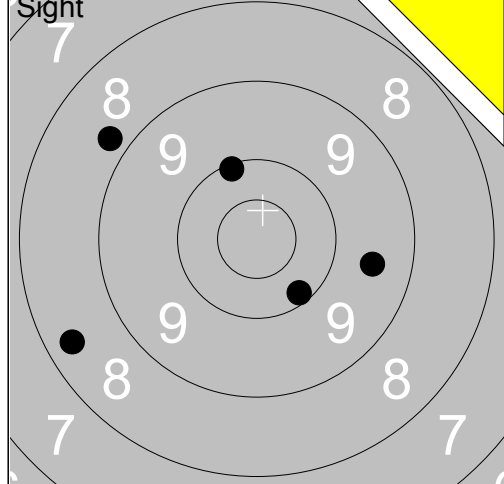

1:	10.1	↗
2:	8.8	↗
3:	10.1	↘
4:	9.5	→
5:	7.3	↗
6:	8.4	↖
<b>Series</b>		<b>52.0</b>
<b>Total</b>		<b>0.0</b>

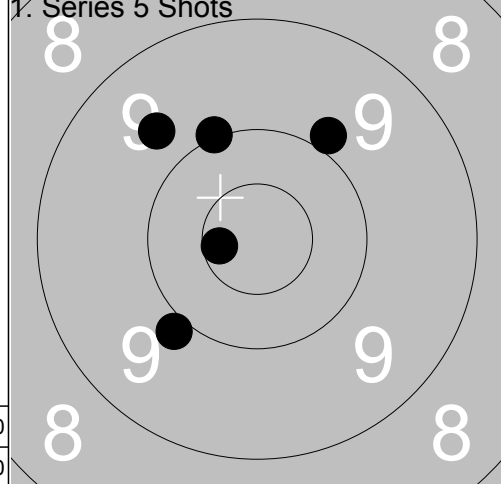

1:	9.9	↖
2:	9.7	↗
3:	10.0	↗
4:	9.9	↗
5:	*10.6	←
<b>Series</b>		<b>47.0</b>
<b>Total</b>		<b>47.0</b>

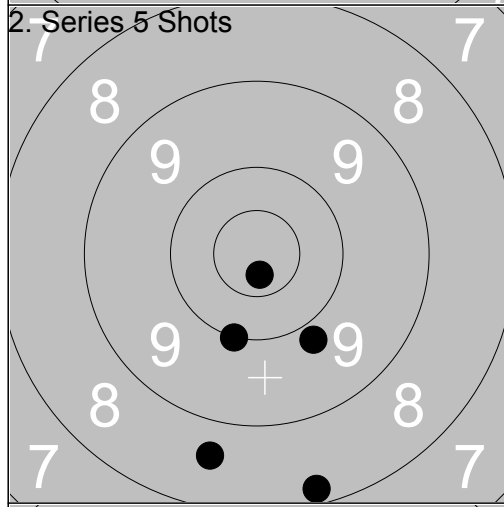

1:	*10.7	↓
2:	10.0	↓
3:	8.6	↓
4:	8.2	↓
5:	9.8	↓
<b>Series</b>		<b>45.0</b>
<b>Total</b>		<b>92.0</b>

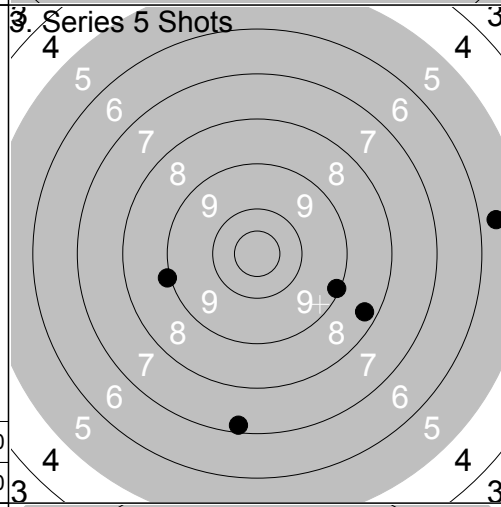

1:	5.7	→
2:	7.2	↓
3:	8.3	↘
4:	9.1	→
5:	9.0	←
<b>Series</b>		<b>38.0</b>
<b>Total</b>		<b>130.0</b>

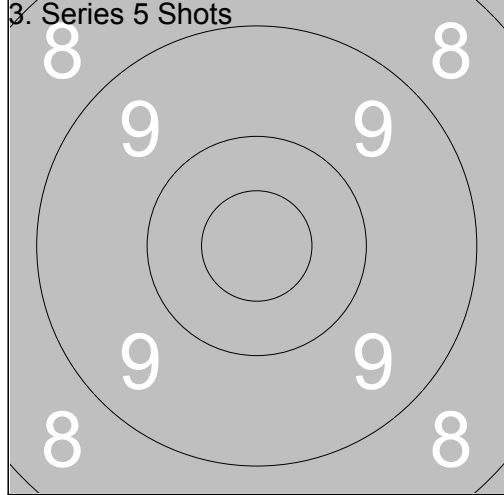

6:	0.0	
<b>Series</b>		<b>0.0</b>
<b>Total</b>		<b>130.0</b>

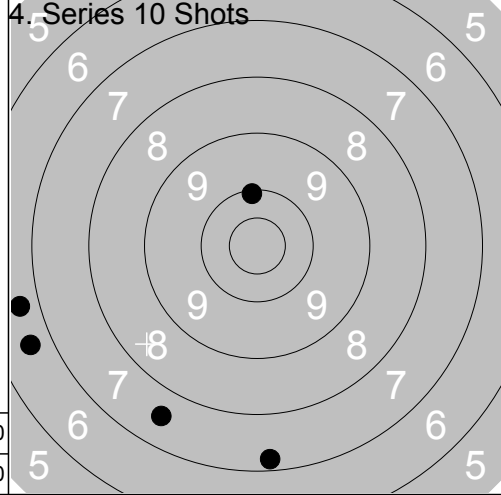

1:	6.6	←
2:	6.7	←
3:	7.6	↘
4:	7.2	↓
5:	10.1	↑
<b>Series</b>		<b>36.0</b>
<b>Total</b>		<b>166.0</b>

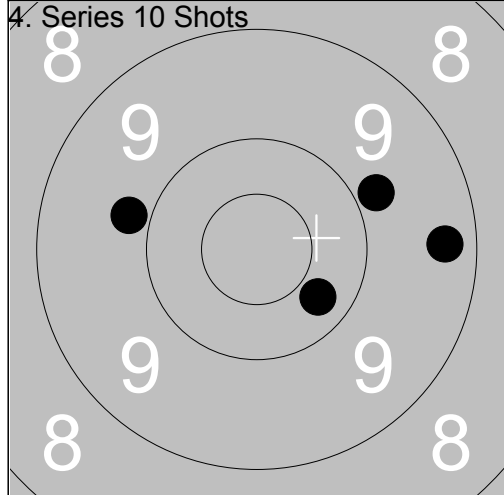

6:	9.3	→
7:	9.8	↗
8:	9.8	↖
9:	10.3	↘
<b>Series</b>		<b>37.0</b>
<b>Total</b>		<b>203.0</b>



Relay <b>3</b>	Lane <b>14</b>	<b>Mattias Eriksson</b>
-------------------	-------------------	-------------------------

300m	Ramselefors	E	Vb
------	-------------	---	----

07.07.2014	Tavelträffen B 2014	Ramselefors SKF
------------	---------------------	-----------------

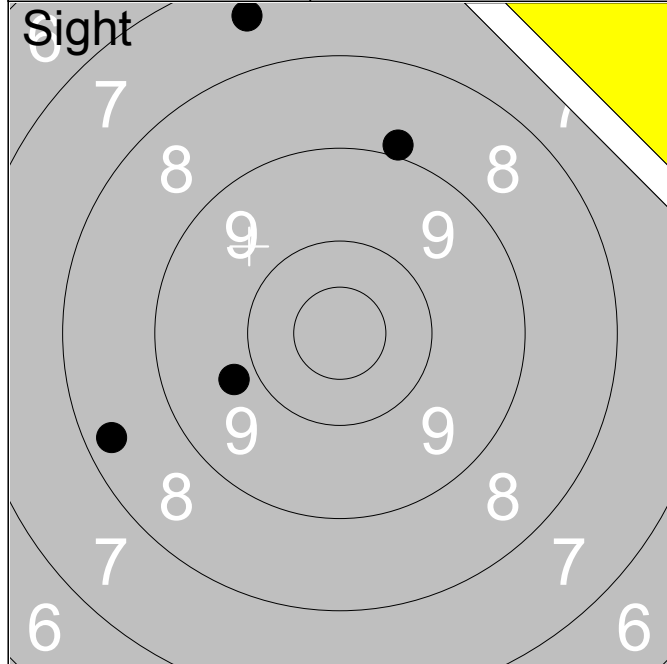

1:	7.5	↑
2:	8.9	↑
3:	9.8	↙
4:	8.3	↙
Series	32.0	
Total	0.0	

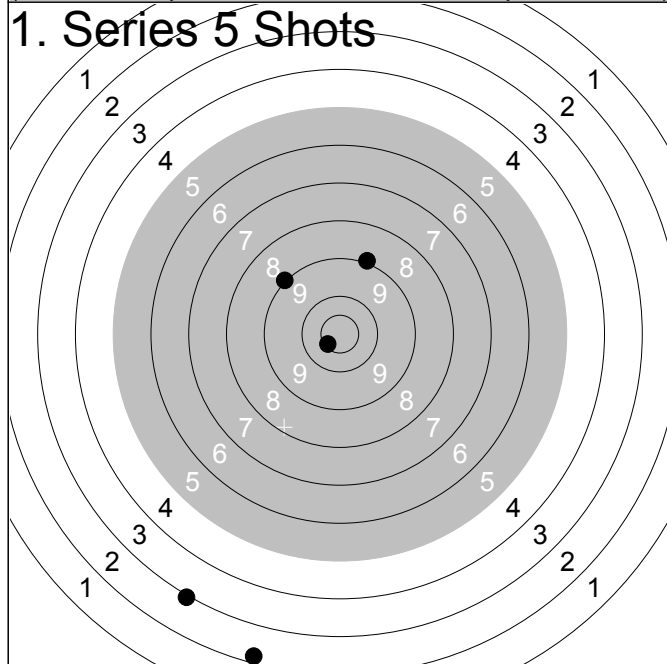

1:	9.0	↑
2:	*10.6	↙
3:	9.0	↖
4:	3.0	↙
5:	2.2	↙
Series	33.0	
Total	33.0	

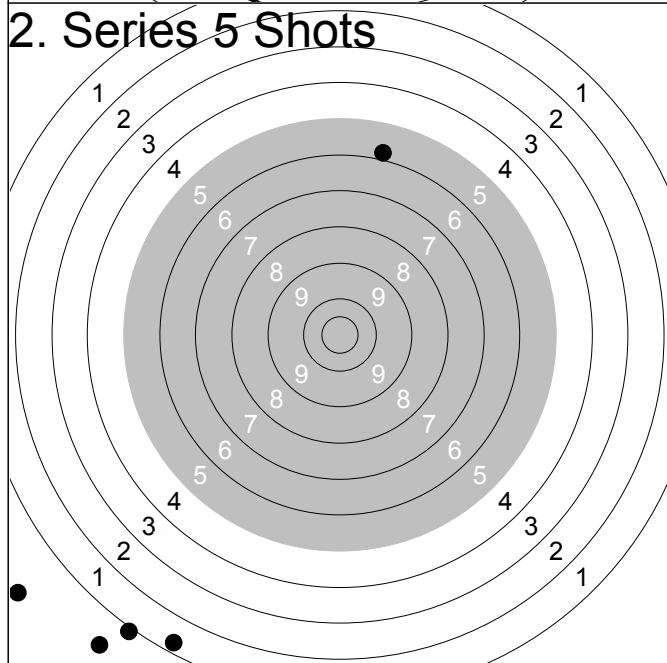

1:	5.8	↑
2:	1.3	↙
3:	0.0	↙
4:	0.0	↙
5:	0.0	↙
Series	6.0	
Total	39.0	

<p>Sight</p> <p>1: 10.0 ↘ 2: 10.4 ← 3: 9.6 ← 4: 10.4 ↑</p>	<p>1. Series 5 Shots</p> <p>1: 10.1 ↖ 2: *10.5 → 3: *10.8 ↘ 4: 10.0 ↖ 5: 8.9 ↑</p>	
Series 39.0	Series 48.0	
Total 0.0	Total 48.0	

<p>2. Series 5 Shots</p> <p>1: 9.5 → 2: 9.7 ↘ 3: 9.2 ↘ 4: 10.3 → 5: *10.7 ↘</p>	<p>3. Series 5 Shots</p> <p>1: *10.8 ↖ 2: *10.6 ↖ 3: 10.1 ↑ 4: 10.2 → 5: 9.9 ←</p>	
Series 47.0	Series 49.0	
Total 95.0	Total 144.0	

<p>4. Series 10 Shots</p> <p>1: 9.1 → 2: 8.5 → 3: 6.6 → 4: 8.7 → 5: 7.3 →</p>	<p>4. Series 10 Shots</p> <p>6: 6.9 → 7: 8.7 → 8: 6.7 → 9: 6.7 → 10: 8.4 →</p>	
Series 38.0	Series 34.0	
Total 182.0	Total 216.0	

<p><b>Sight</b></p>	<p><b>1. Series 5 Shots</b></p>	<p>1: 10.4 ↗</p> <p>2: *10.5 ↓</p> <p>3: 9.4 ↓</p> <p>4: 6.6 ↘</p> <p>5: 9.6 →</p> <p>6: 10.0 →</p>	<p>1: *10.5 ↓</p> <p>2: 9.4 ↓</p> <p>3: 9.1 ↓</p> <p>4: 10.0 ↘</p> <p>5: *10.7 ↓</p>
<b>Series</b> 54.0	<b>Series</b> 48.0	<b>Total</b> 0.0	<b>Total</b> 48.0

<p><b>2. Series 5 Shots</b></p>	<p><b>3. Series 5 Shots</b></p>	<p>1: 9.8 →</p> <p>2: *10.5 ↗</p> <p>3: 10.2 ↙</p> <p>4: 9.1 →</p> <p>5: 9.5 ↓</p>	<p>1: 10.0 ↓</p> <p>2: 9.3 ↓</p> <p>3: 8.9 →</p> <p>4: 9.7 ↓</p> <p>5: 9.6 ↓</p>
<b>Series</b> 47.0	<b>Series</b> 45.0	<b>Total</b> 95.0	<b>Total</b> 140.0

<p><b>4. Series 10 Shots</b></p>	<p><b>4. Series 10 Shots</b></p>	<p>1: 8.4 →</p> <p>2: 9.2 →</p> <p>3: 3.6 →</p> <p>4: 5.0 →</p> <p>5: 2.1 →</p>	<p>6: 9.0 →</p> <p>7: 7.9 →</p> <p>8: 8.9 →</p> <p>9: 6.9 ↗</p> <p>10: 9.6 ↘</p>
<b>Series</b> 27.0	<b>Series</b> 39.0	<b>Total</b> 167.0	<b>Total</b> 206.0

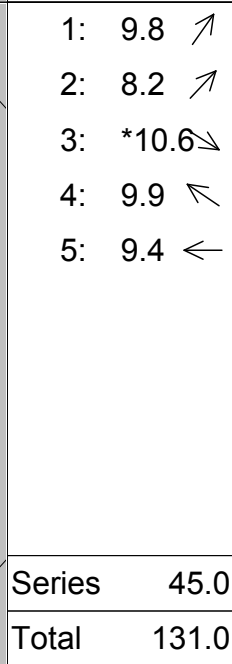
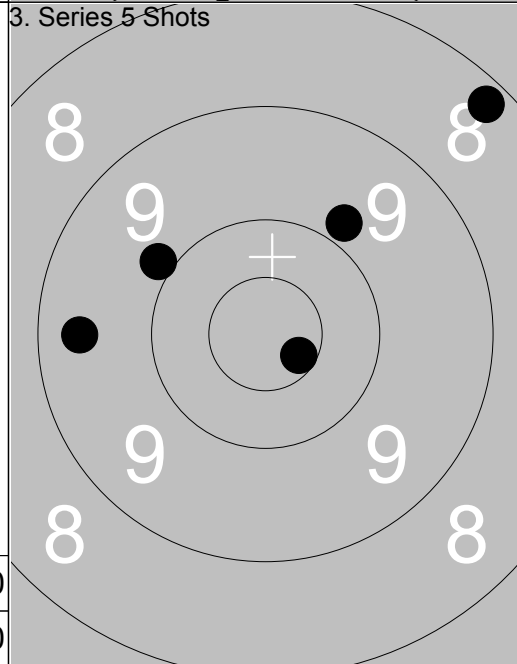
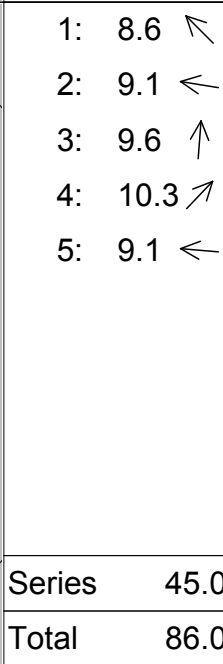
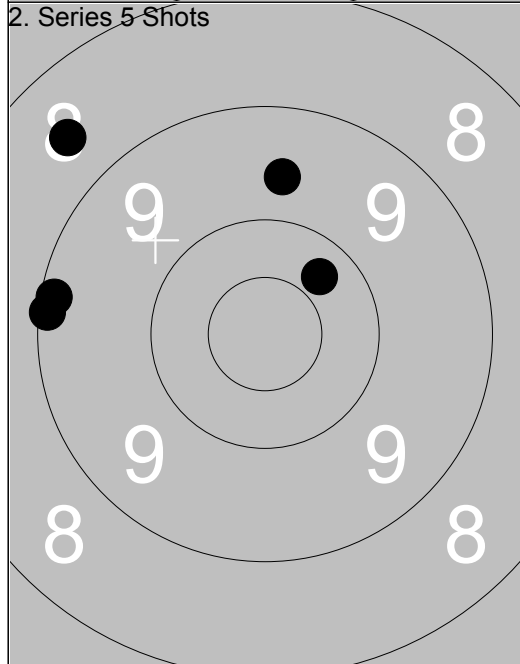
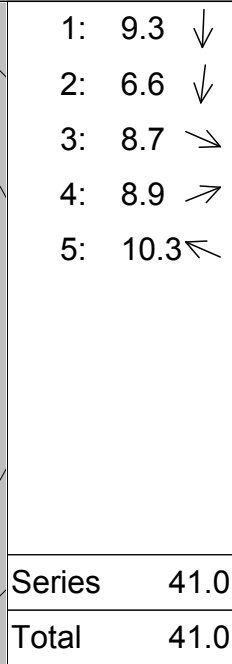
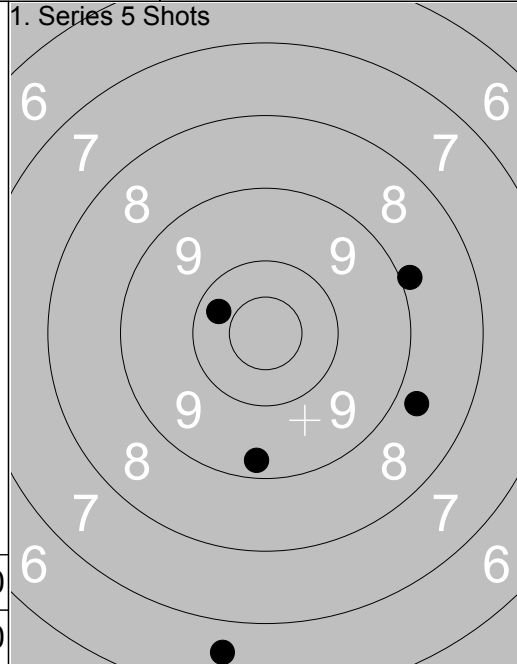
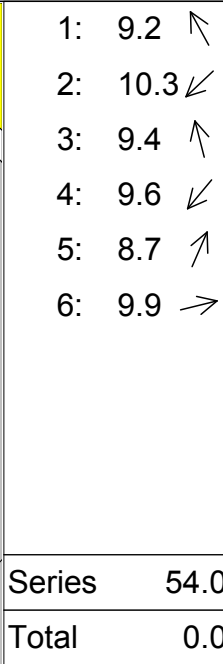
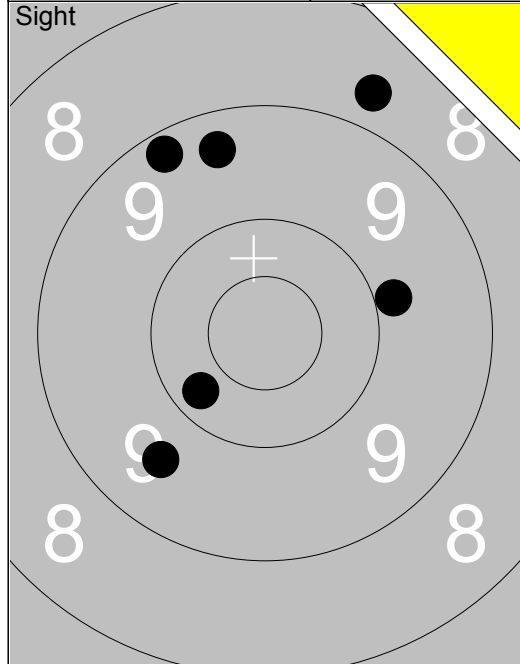

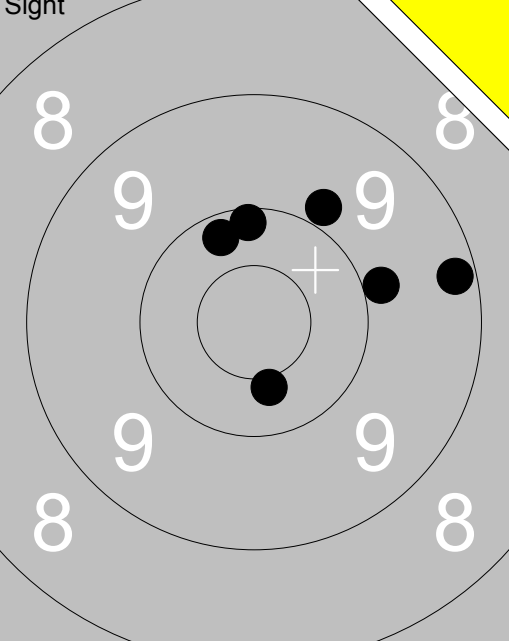
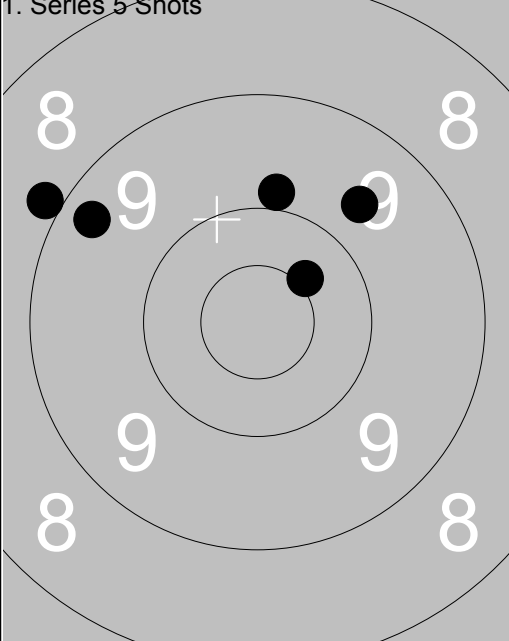
<p>Sight</p> 	<p>1: 9.9 →</p> <p>2: 9.9 ↗</p> <p>3: 10.1 ↑</p> <p>4: 9.2 →</p> <p>5: 10.4 ↓</p> <p>6: 10.2 ↗</p>	<p>1. Series 5 Shots</p> 	<p>1: 9.7 ↗</p> <p>2: 9.3 ↖</p> <p>3: 9.9 ↑</p> <p>4: 8.9 ↖</p> <p>5: *10.4 ↗</p>
Series 57.0		Series 45.0	
Total 0.0		Total 45.0	

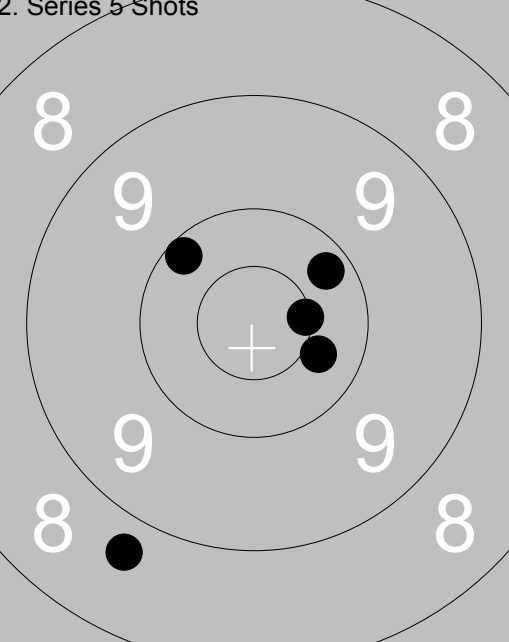
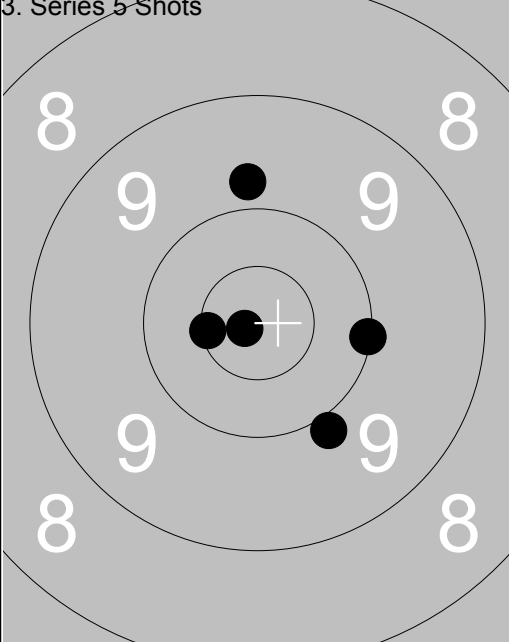
<p>2. Series 5 Shots</p> 	<p>1: 8.7 ↓</p> <p>2: *10.5 →</p> <p>3: 10.4 →</p> <p>4: 10.2 ↖</p> <p>5: 10.2 ↗</p>	<p>3. Series 5 Shots</p> 	<p>1: *10.5 ↖</p> <p>2: *10.8 ↖</p> <p>3: 9.8 ↑</p> <p>4: 9.9 ↓</p> <p>5: 10.0 →</p>
Series 48.0		Series 48.0	
Total 93.0		Total 141.0	

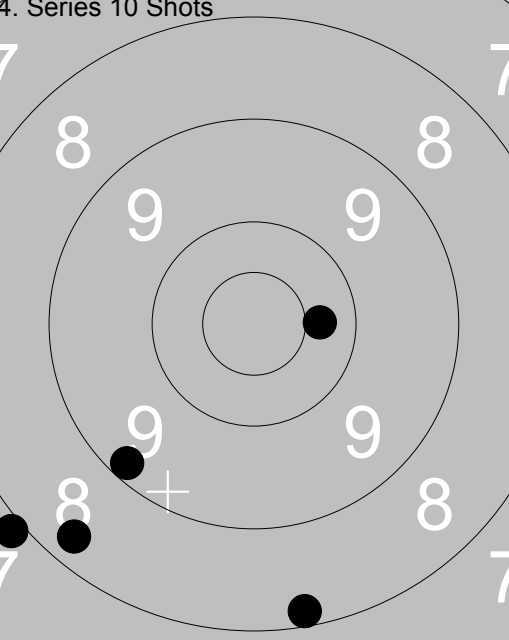
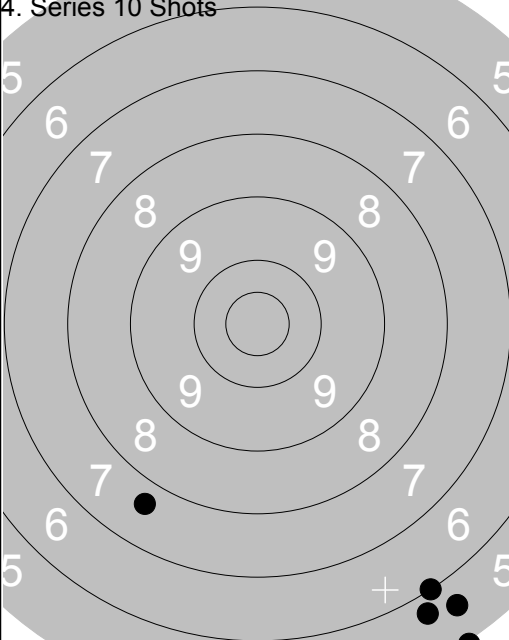
<p>4. Series 10 Shots</p> 	<p>1: 7.9 ↖</p> <p>2: 8.3 ↖</p> <p>3: 9.2 ↖</p> <p>4: 8.2 ↓</p> <p>5: 10.4 →</p>	<p>4. Series 10 Shots</p> 	<p>6: 5.6 ↓</p> <p>7: 5.0 ↓</p> <p>8: 6.0 ↓</p> <p>9: 5.7 ↓</p> <p>10: 7.7 ↓</p>
Series 42.0		Series 28.0	
Total 183.0		Total 211.0	

Relay <b>3</b>	Lane <b>21</b>	<b>Leif Sigfridsson</b>	
-------------------	-------------------	-------------------------	--

300m	Ramselefors	E	Vb
------	-------------	---	----

07.07.2014	Tavelträffen B 2014	Ramselefors SKF
------------	---------------------	-----------------

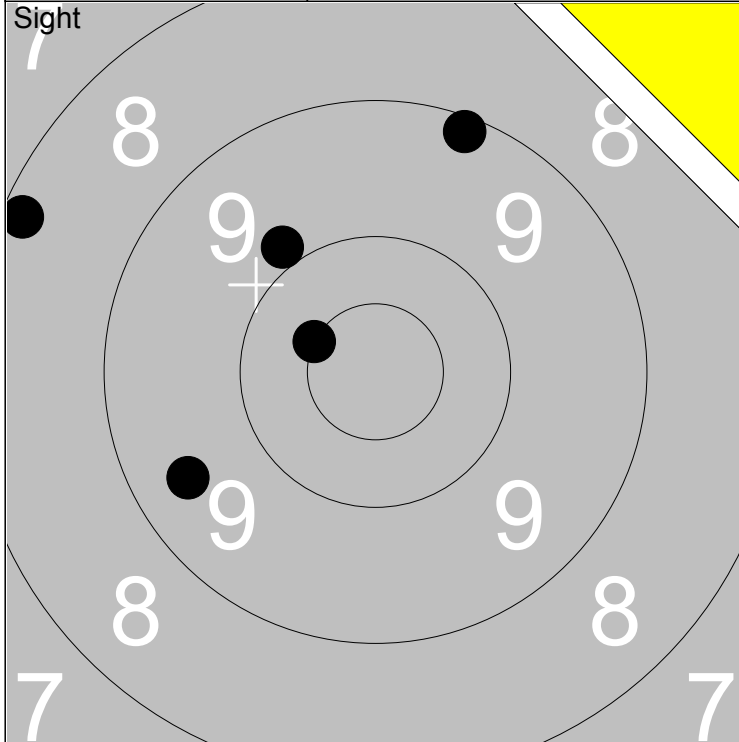

1: 8.2 ↖	Series	45.0
2: 9.9 ↗		
3: 9.4 ↖	Total	0.0
4: *10.5 ↖		
5: 9.1 ↗		

1: 9.7 ↓	Series	44.0
2: 7.8 ↓		
3: 9.9 ↖	Total	44.0
4: 10.0 ↗		
5: 9.8 ↗		

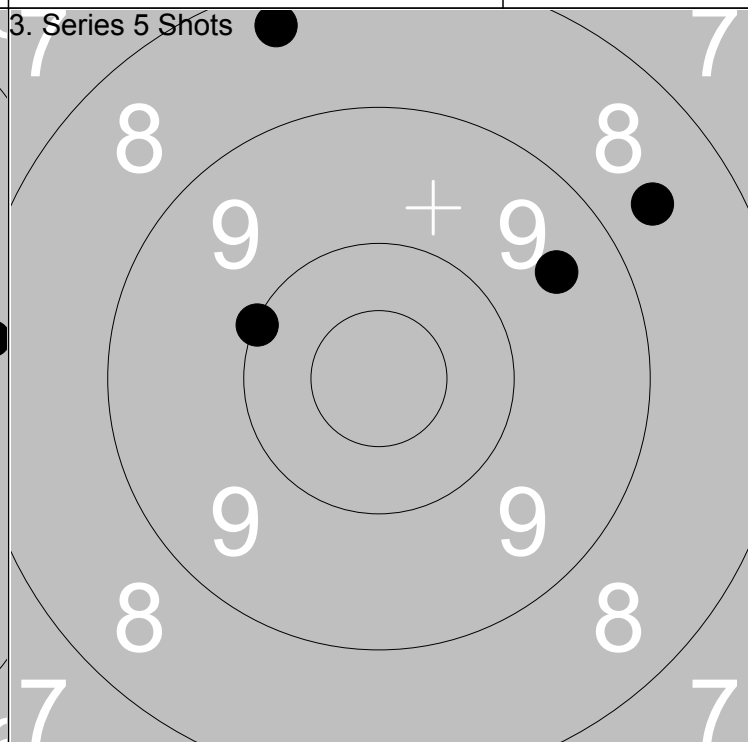
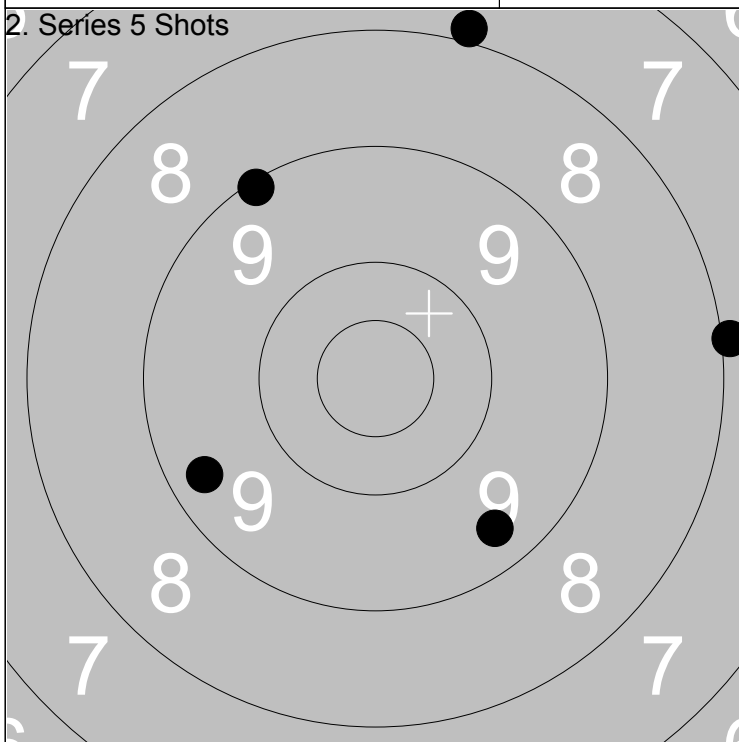

1: 9.1 ↗	Series	42.0
2: 8.0 →		
3: 9.4 ↓	Total	86.0
4: 9.3 ↖		
5: 7.9 ↗		

1: 0.0	Series	35.0
2: 9.5 ↗		
3: 8.6 ↗	Total	121.0
4: 8.3 ↗		
5: 10.0 ↖		

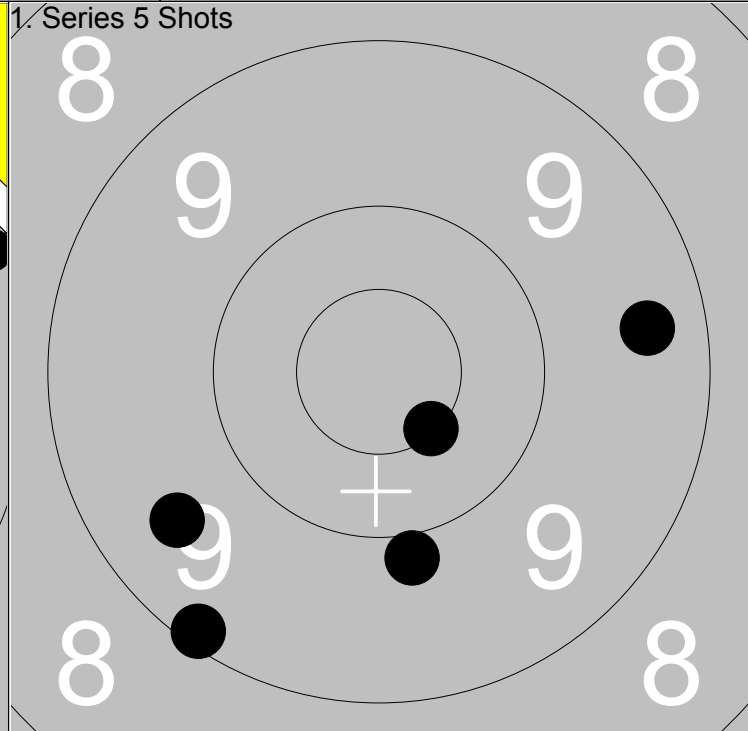
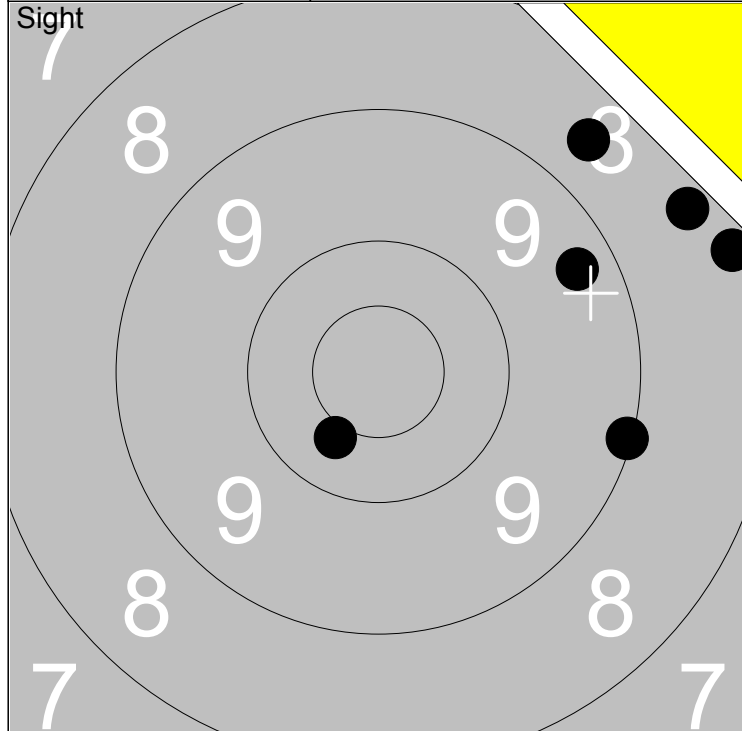

1: 9.1 →	6: 8.2 →				
2: 8.4 →		Series	52.0		
3: 8.6 ↗					
4: 10.4 ↓		Total	0.0		
5: 9.3 →					

1: 9.9 ↓					
2: 9.1 ↓		Series	46.0		
3: 9.5 ↙					
4: *10.5 ↓		Total	46.0		
5: 9.4 →					

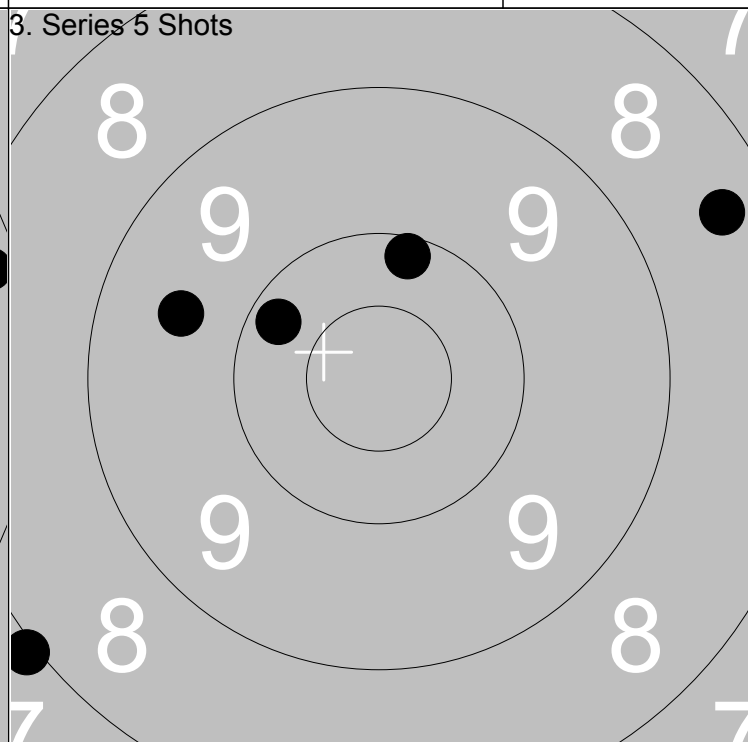
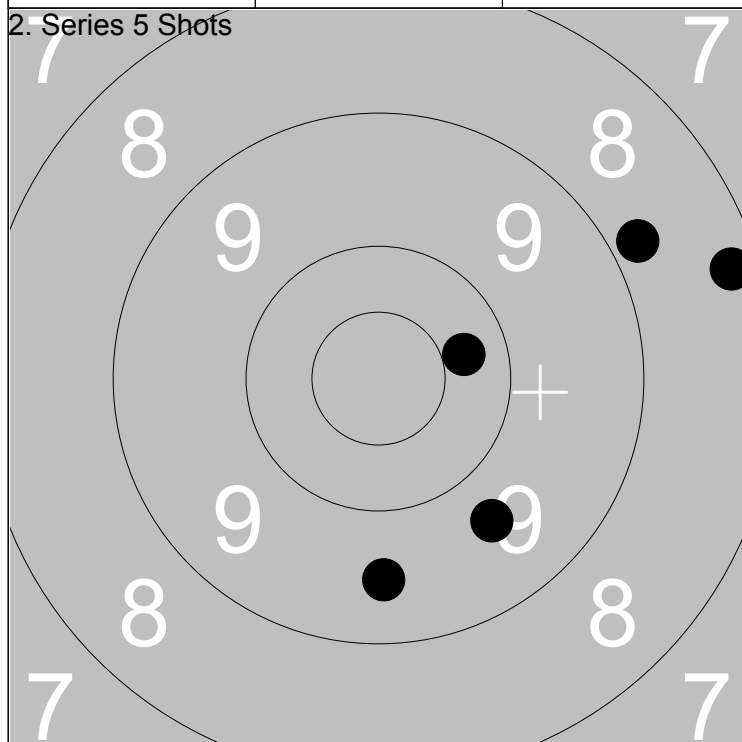

1: 9.7 ↓					
2: 10.3 →		Series	44.0		
3: 9.5 ↓					
4: 8.2 →		Total	90.0		
5: 8.8 ↗					

1: 8.0 ↙					
2: 10.2 ↖		Series	45.0		
3: 9.6 ↖					
4: 8.4 →		Total	135.0		
5: 10.1 ↑					