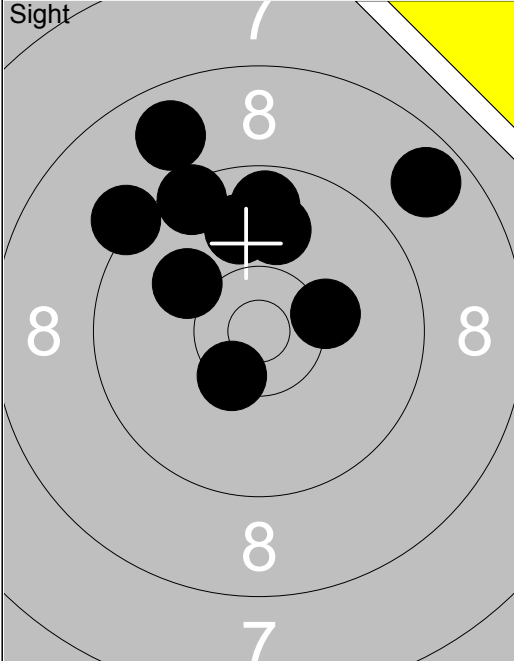
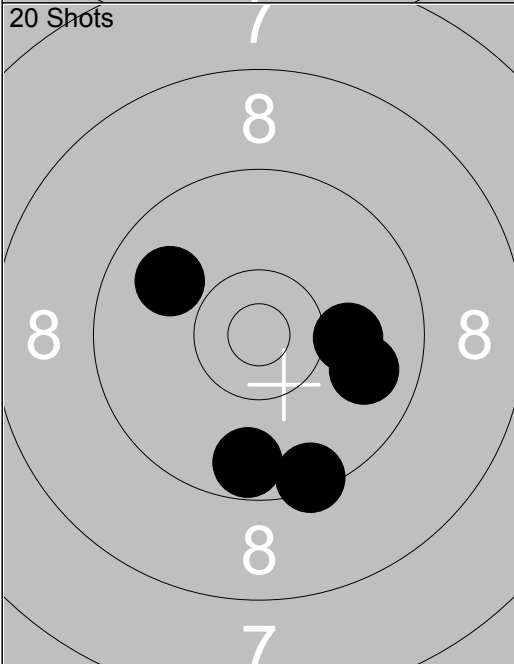
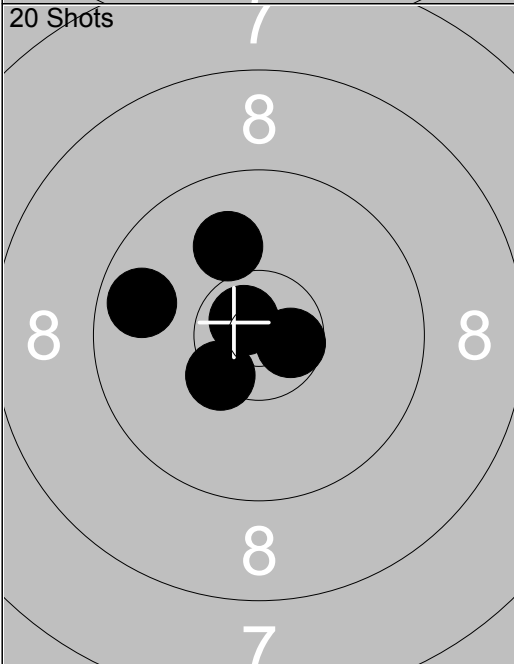
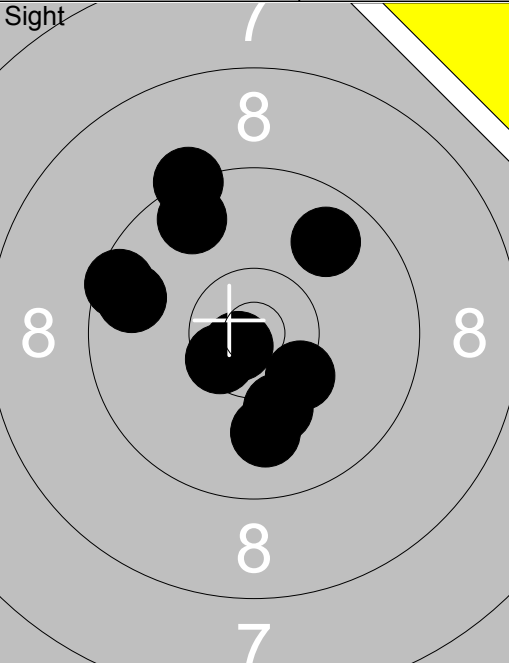
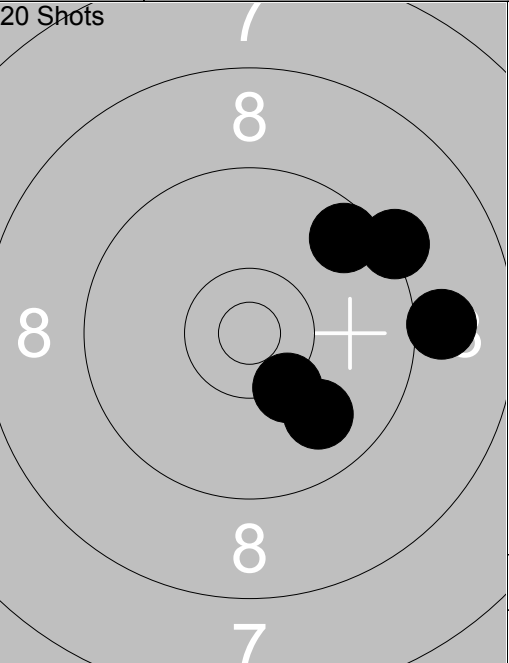
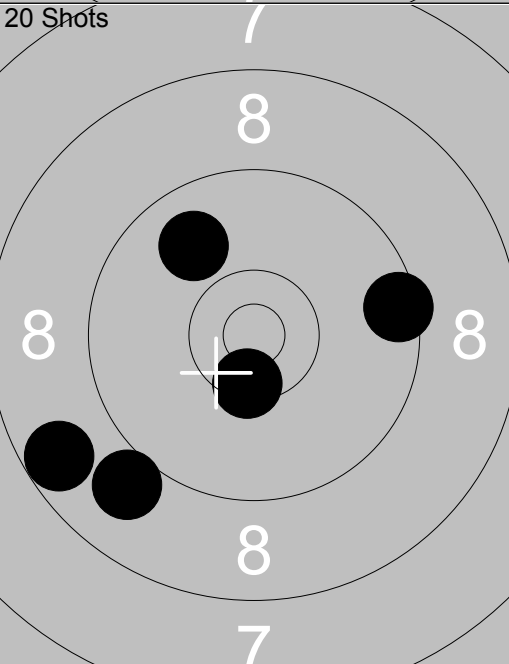
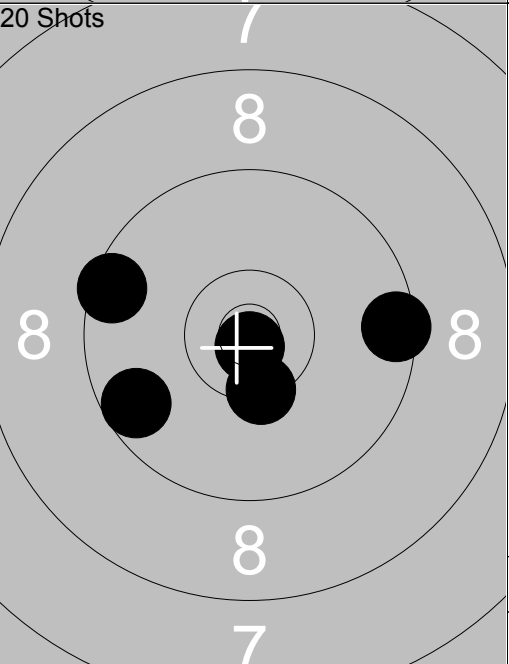
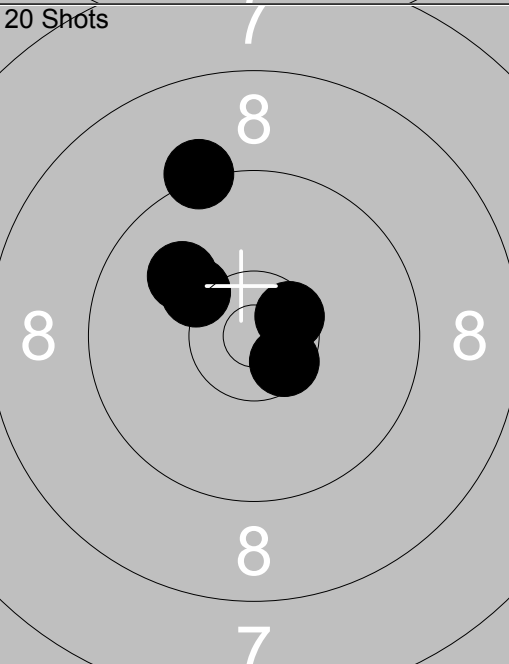
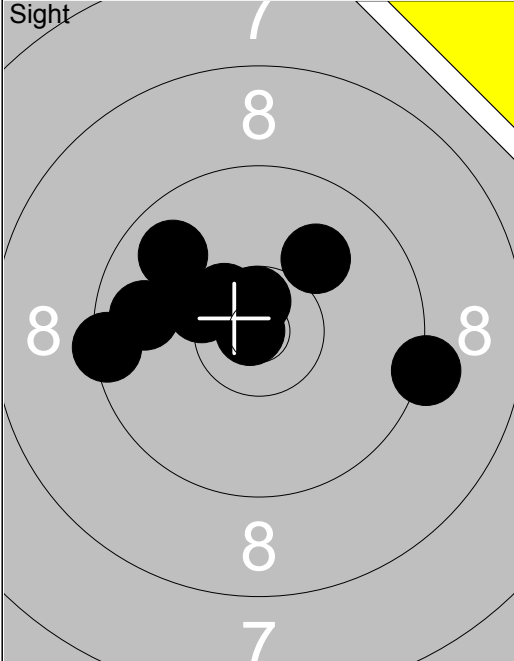
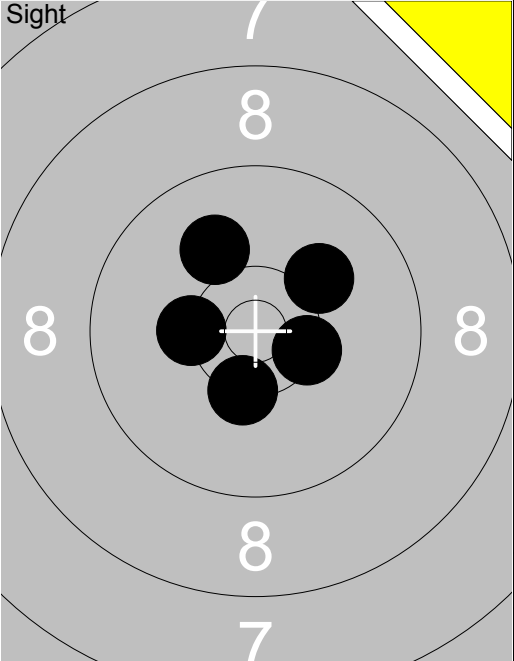
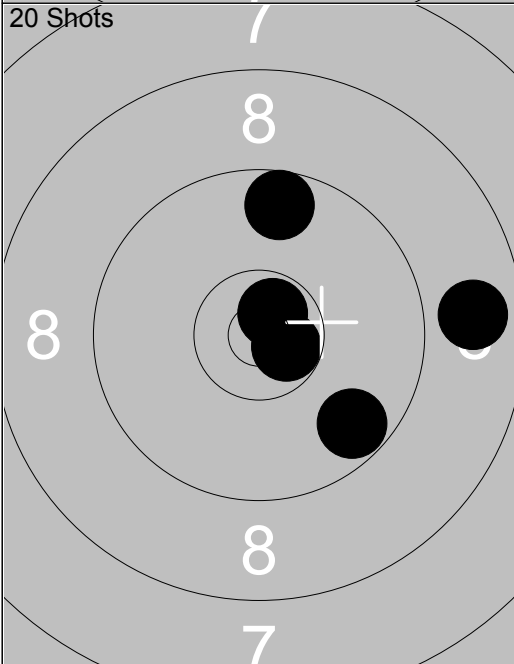
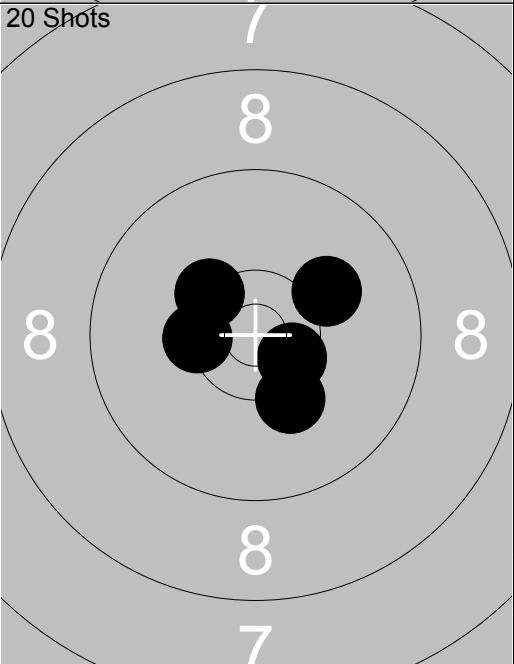
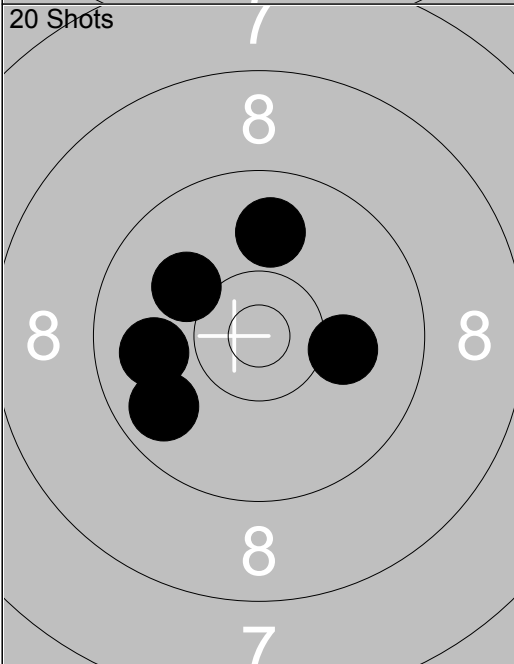
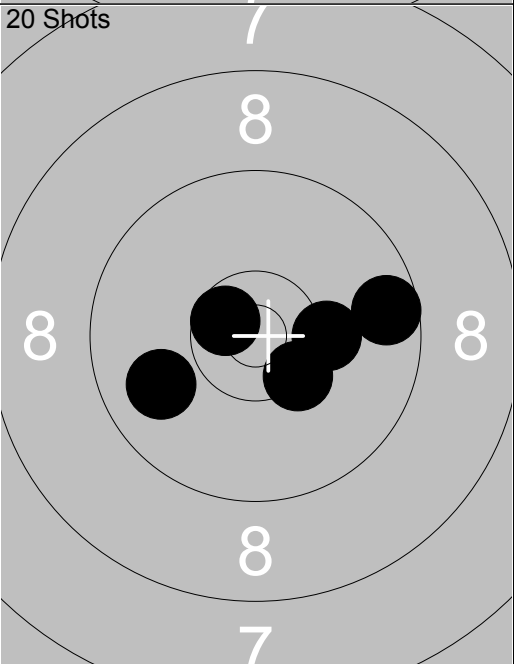
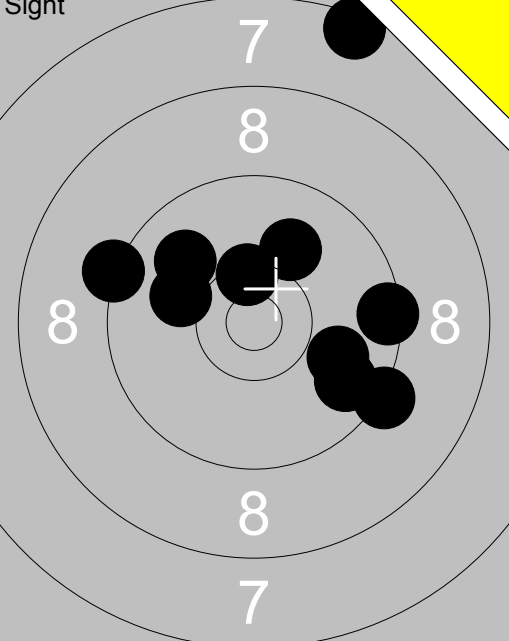
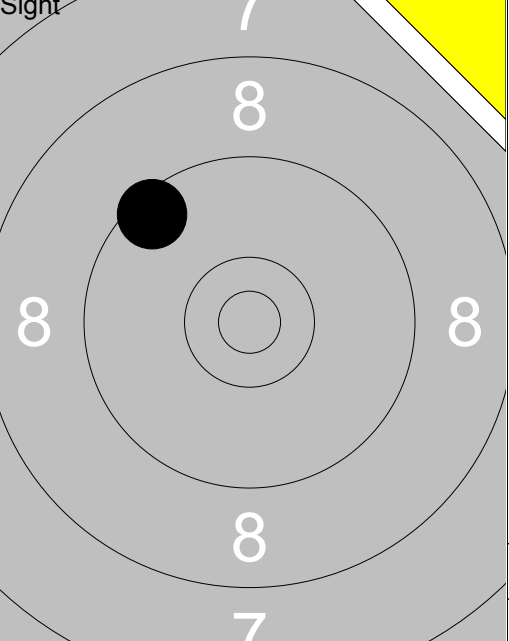
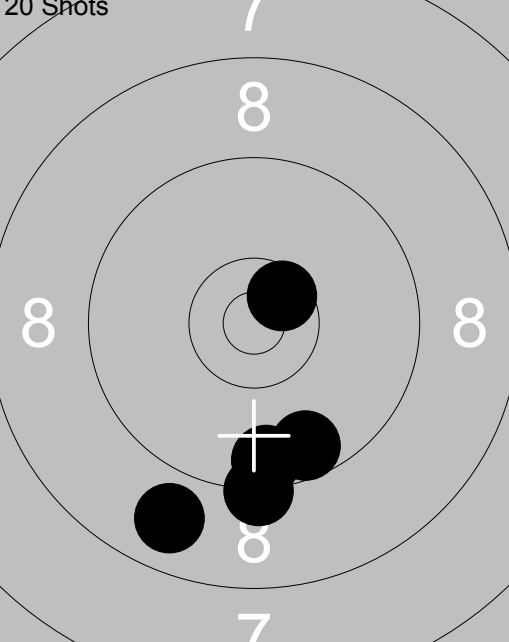
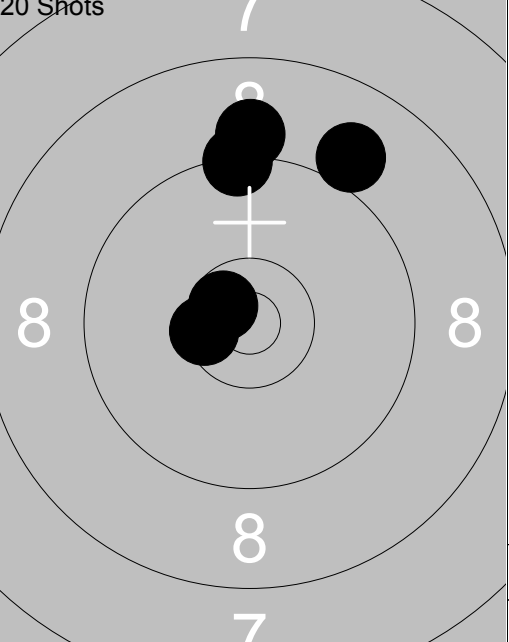

Relay	Lane	Dan-Ivan Karlsson	
50m		Ramselefors	Vet-L Vb
08.07.2014		Tavelträffen Korthäll 2014	Ramselefors SKF
Sight		1: 8.7 ↗ 2: 9.5 ↖ 3: 9.9 ↑ 4: 8.8 ↖ 5: 10.3 → 6: 9.7 ↑ 7: 10.1 ↖ 8: 9.2 ↖ 9: 9.9 ↑ 10: *10.4 ↘	11: *10.3 ↘ 12: *10.5 ↖
		Series 91.0	Series 20.0
		Total 0.0	Total 0.0
20 Shots		1: 9.7 ↓ 2: 9.4 ↓ 3: 9.9 ↖ 4: 10.1 → 5: 9.8 →	6: *10.8 ↘ 7: 9.6 ↖ 8: *10.6 ↘ 9: 10.0 ↑ 10: *10.3 ↗
		Series 46.0	Series 49.0
		Total 46.0	Total 95.0
20 Shots		11: *10.6 → 12: *10.4 ↘ 13: *10.7 ↖ 14: 10.0 ↑ 15: 9.7 ←	16: 9.0 ↖ 17: *10.4 ↘ 18: 9.6 ← 19: *10.7 ↗ 20: 7.8 ↖
		Series 49.0	Series 45.0
		Total 144.0	Total 189.0

Relay	Lane	Johan Nilsson	
1	2		
50m	Ramselefors	Sen-L	Vb
08.07.2014	Tavelträffen Korthäll 2014	Ramselefors SKF	
Sight		1: 9.7 ↖ 2: *10.5 ↘ 3: 9.5 ← 4: 9.3 ↖ 5: *10.7 ↘ 6: *10.3 ↘ 7: 9.8 ↗ 8: 10.0 ↓ 9: 10.2 ↓ 10: 9.7 ←	20 Shots  1: 9.9 ↘ 2: 9.0 → 3: 9.2 ↗ 4: 9.6 ↗ 5: *10.3 ↘
		Series 95.0	Series 46.0
		Total 0.0	Total 46.0
20 Shots		6: 9.5 → 7: 8.7 ← 8: 9.0 ← 9: 9.9 ↖ 10: *10.5 ↓	20 Shots  11: *10.4 ↓ 12: *10.8 ↓ 13: 9.6 ← 14: 9.5 ← 15: 9.5 →
		Series 45.0	Series 47.0
		Total 91.0	Total 138.0
20 Shots		16: *10.6 ↘ 17: 10.2 ↖ 18: 9.2 ↖ 19: 10.0 ↖ 20: *10.5 ↗	
		Series 49.0	
		Total 187.0	

Relay	Lane	Marlene Forsell	
1	3		
50m	Ramselefors	Sen-L	Vb
08.07.2014	Tavelträffen Korthäll 2014	Ramselefors SKF	
Sight		1: 9.2 → 2: *10.6↑ 3: 9.8 ← 4: *10.9← 5: 9.4 ← 6: 10.0 ↗ 7: 10.3← 8: 9.8 ↗ 9: *10.5↘ 10: *10.3↘ Series 96.0 Total 0.0	Sight  11: *10.3← 12: *10.4↓ 13: 10.1 ↗ 14: 10.0 ↗ 15: *10.4→ Series 50.0 Total 0.0
20 Shots		1: *10.7↗ 2: 9.7 ↓ 3: 9.6 ↑ 4: 8.8 → 5: *10.7→ Series 46.0 Total 46.0	20 Shots  6: *10.4← 7: *10.5↘ 8: *10.3↘ 9: 10.1 ↗ 10: 10.2 ↓ Series 50.0 Total 96.0
20 Shots		11: 10.1→ 12: 9.8 ← 13: 9.9 ← 14: 10.1↘ 15: 9.9 ↑ Series 47.0 Total 143.0	20 Shots  16: *10.6↘ 17: 10.2→ 18: *10.4↘ 19: 9.9 ← 20: 9.6 → Series 48.0 Total 191.0

<p>Sight</p> 	<p>1: 7.5 ↗ 2: 9.7 ➡ 3: 9.9 ➡ 4: 9.4 ➡ 5: 10.0 ↗ 6: 9.3 ↖ 7: 9.9 ↗ 8: *10.4 ↗ 9: 9.3 ➡ 10: 10.1 ↖</p>	<p>Sight</p> 	<p>11: 9.5 ↖</p>
Series 91.0		Series 9.0	
Total 0.0		Total 0.0	

<p>20 Shots</p> 	<p>1: *10.6 ↗ 2: 8.8 ↘ 3: 9.6 ↘ 4: 9.6 ↘ 5: 9.3 ↘</p>	<p>20 Shots</p> 	<p>6: *10.6 ↘ 7: 9.0 ↗ 8: *10.5 ↖ 9: 9.1 ↗ 10: 9.3 ↗</p>
Series 45.0		Series 47.0	
Total 45.0		Total 92.0	

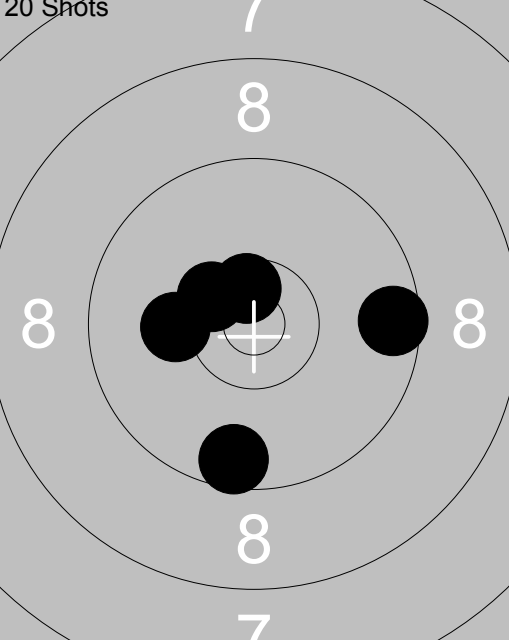
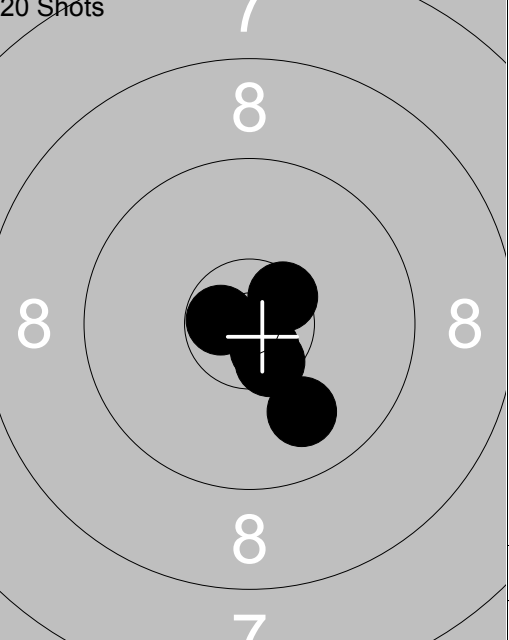
<p>20 Shots</p> 	<p>11: *10.4 ↖ 12: 10.2 ↖ 13: 9.6 ➡ 14: 9.6 ↘ 15: *10.6 ↗</p>	<p>20 Shots</p> 	<p>16: *10.5 ↘ 17: *10.7 ↖ 18: *10.7 ↘ 19: *10.5 ↗ 20: 9.9 ↘</p>
Series 48.0		Series 49.0	
Total 140.0		Total 189.0	

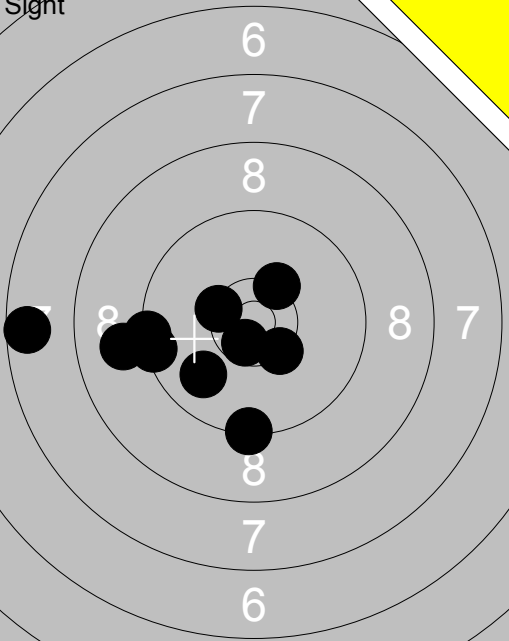
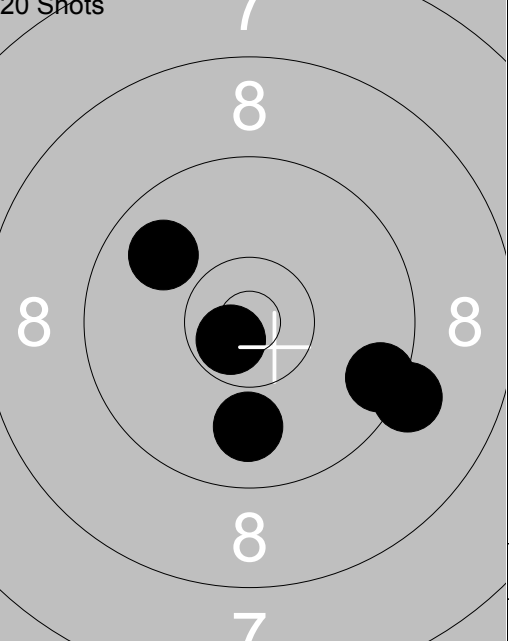
<p>Sight</p> 	<p>1: 9.0 ←</p> <p>2: 7.6 ←</p> <p>3: 9.4 ←</p> <p>4: 9.4 ←</p> <p>5: *10.6 ↙</p> <p>6: 9.3 ↓</p> <p>7: 9.9 ↙</p> <p>8: *10.3 ↗</p> <p>9: *10.4 ↖</p> <p>10: *10.4 ↘</p>	<p>20 Shots</p> 		<p>1: 9.9 ↓</p> <p>2: 9.2 →</p> <p>3: 9.5 →</p> <p>4: 9.9 ↖</p> <p>5: *10.7 ↙</p>
Series 92.0				Series 46.0
Total 0.0				Total 46.0

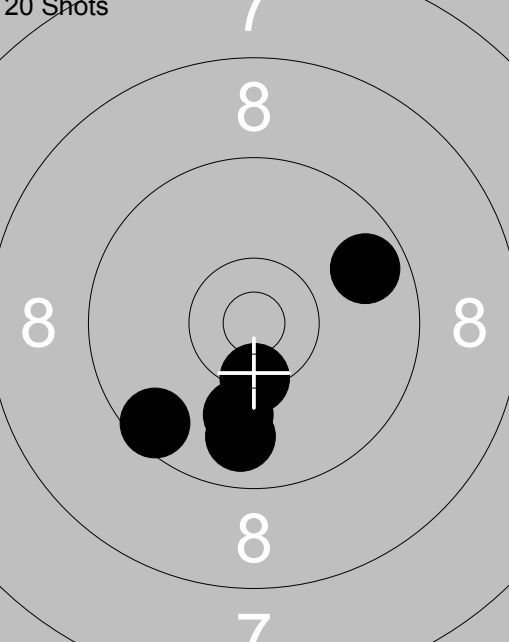
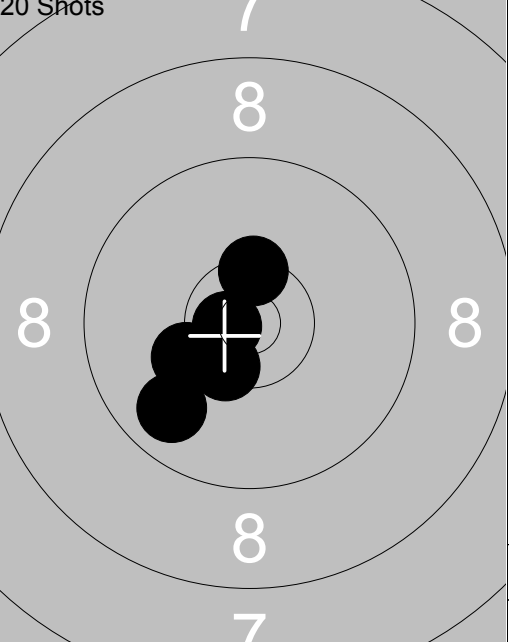
<p>20 Shots</p> 	<p>6: 9.7 →</p> <p>7: *10.4 ↓</p> <p>8: 10.0 ↓</p> <p>9: 9.5 ↙</p> <p>10: 9.8 ↓</p>	<p>20 Shots</p> 		<p>11: 9.8 ↙</p> <p>12: *10.7 ↖</p> <p>13: 10.2 ↙</p> <p>14: *10.5 ↙</p> <p>15: *10.4 ↑</p>
Series 47.0				Series 49.0
Total 93.0				Total 142.0

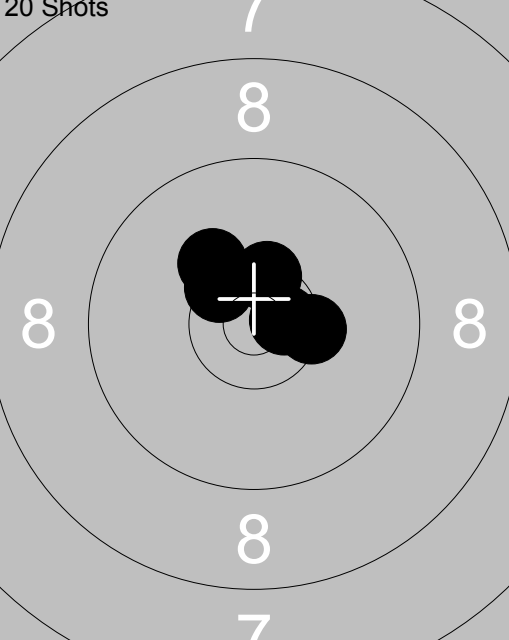
<p>20 Shots</p> 	<p>16: 10.2 ↖</p> <p>17: *10.4 ↖</p> <p>18: *10.4 →</p> <p>19: *10.6 →</p> <p>20: *10.5 ↑</p>			
Series 50.0				
Total 192.0				

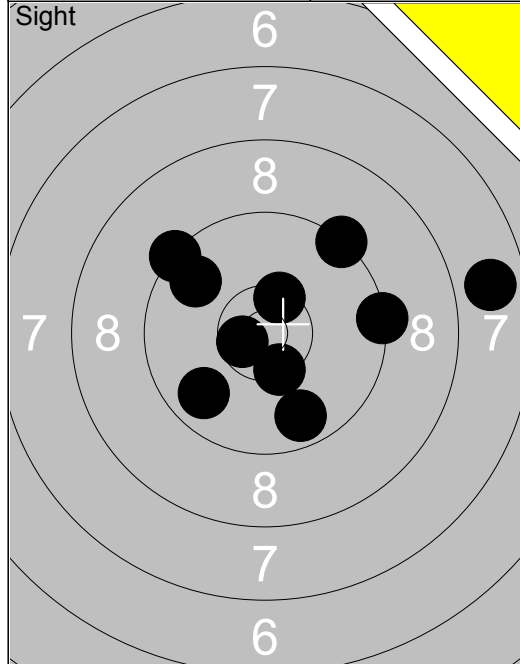

1: 9.7 ↓
2: *10.6 ←
3: *10.4 ↑
4: 9.8 ↖
5: 9.3 ↖
6: 9.8 ↙
7: *10.4 ↓
8: 9.3 →
9: 7.8 →
10: 9.3 ↗
Series 91.0
Total 0.0

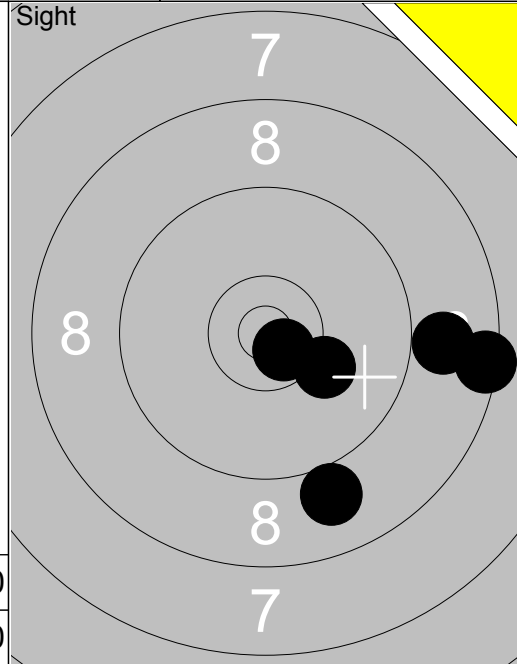

11: 8.4 →
12: 10.2 ↘
13: 8.9 →
14: *10.7 ↘
15: 9.0 ↓
Series 45.0
Total 0.0

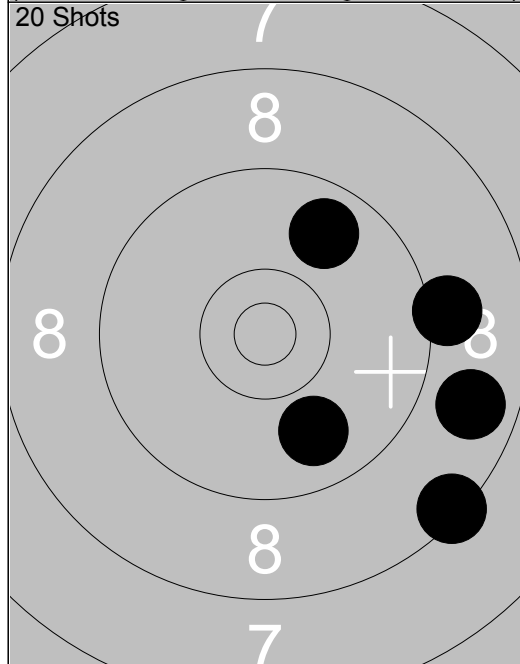

1: 9.8 ↗
2: 9.1 →
3: 8.4 ↓
4: 9.9 ↓
5: 8.8 →
Series 43.0
Total 43.0

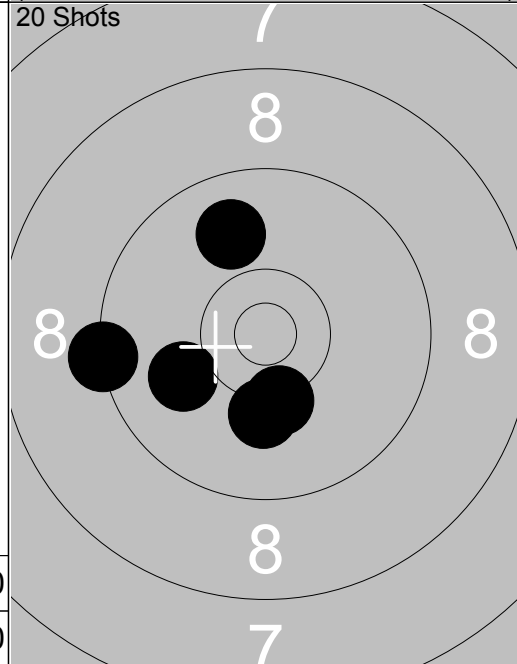

6: 10.2 ↓
7: 9.3 ←
8: 10.3 ↓
9: 10.0 ←
10: 9.9 ↗
Series 48.0
Total 91.0

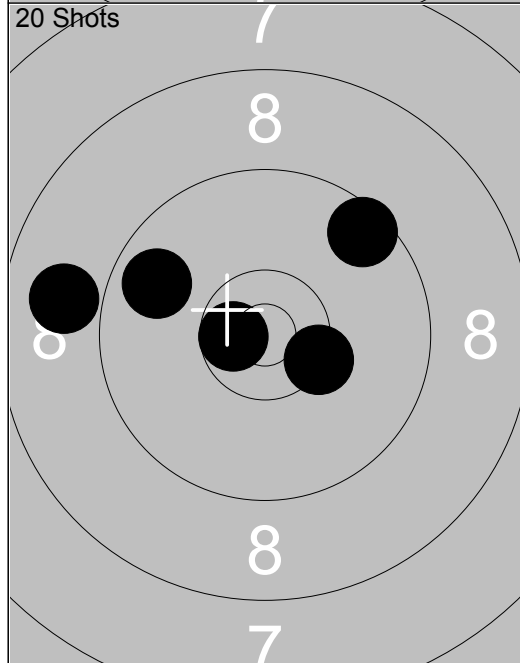

11: 9.5 ↗
12: *10.6 ←
13: 8.9 ←
14: *10.4 ↘
15: 9.8 ←
Series 46.0
Total 137.0

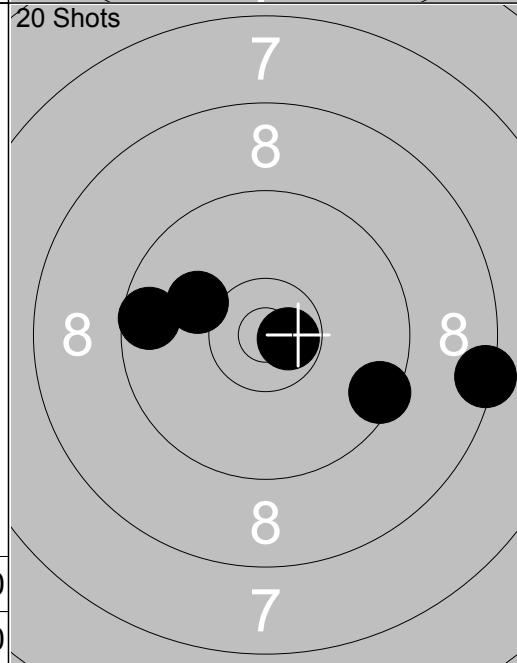

16: 9.6 ←
17: *10.7 →
18: 9.5 ↘
19: 10.1 ↖
20: 8.4 →
Series 46.0
Total 183.0

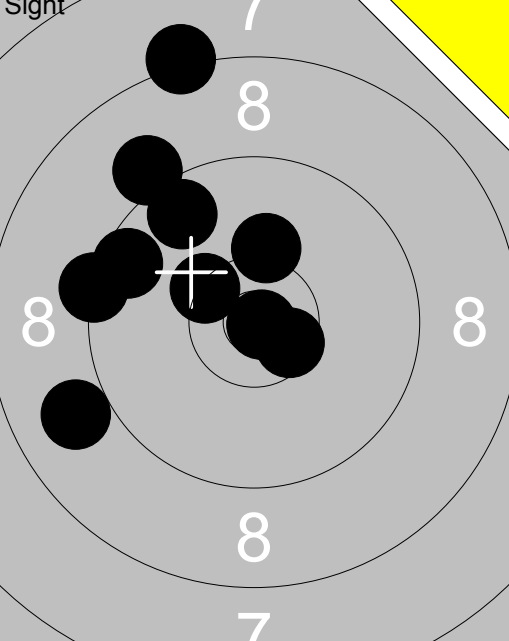
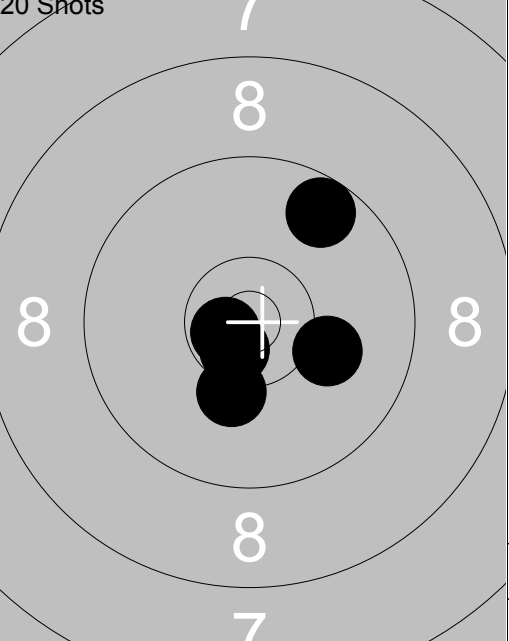
<p>Sight</p>  <p>Target diagram for Sight shot. Shows a cluster of 10 black dots in the center of the target. A yellow triangle is in the top right corner.</p>	<p>1: 8.2 ↑</p> <p>2: 10.2 ↑</p> <p>3: 9.0 ←</p> <p>4: 9.6 ←</p> <p>5: *10.5 →</p> <p>6: *10.9 →</p> <p>7: *10.4 ↖</p> <p>8: 9.7 ↑</p> <p>9: 9.3 ←</p> <p>10: 9.1 ↑</p> <hr/> <p>Series 93.0</p> <p>Total 0.0</p>	<p>20 Shots</p>  <p>Target diagram for 20 Shots. Shows a cluster of 5 black dots in the center of the target.</p>	<p>1: 9.6 ↗</p> <p>2: 10.1 →</p> <p>3: *10.6 ↙</p> <p>4: *10.7 ↙</p> <p>5: 10.2 ↓</p> <hr/> <p>Series 49.0</p> <p>Total 49.0</p>
---	---	---	--

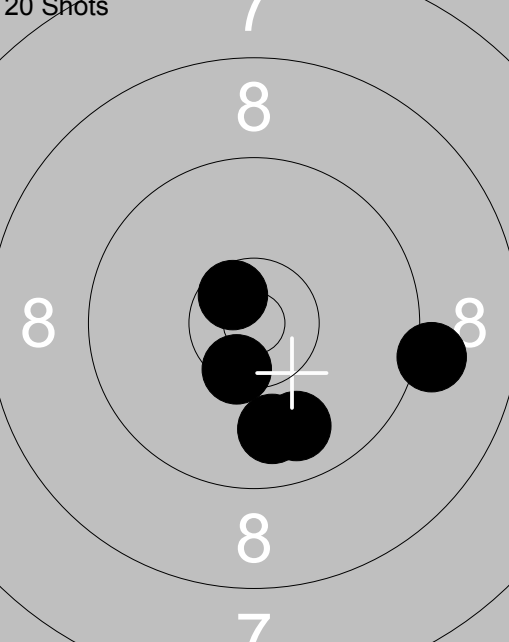
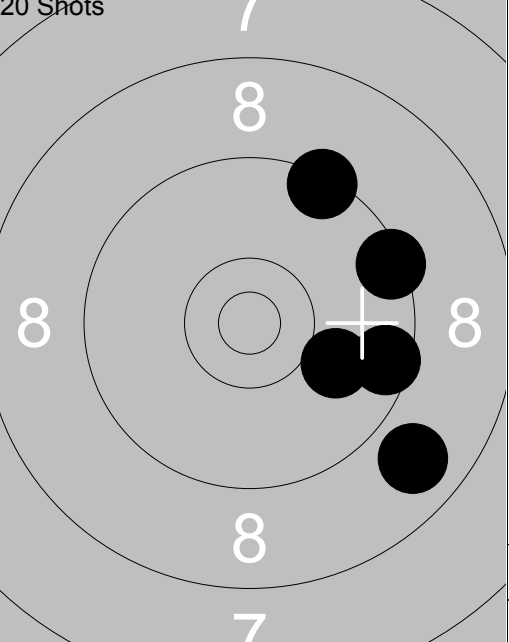
<p>20 Shots</p>  <p>Target diagram for 20 Shots. Shows a cluster of 4 black dots in the center of the target.</p>	<p>6: 9.9 ↓</p> <p>7: 9.1 →</p> <p>8: *10.6 ↖</p> <p>9: 9.8 ↓</p> <p>10: *10.5 ↙</p> <hr/> <p>Series 47.0</p> <p>Total 96.0</p>	<p>20 Shots</p>  <p>Target diagram for 20 Shots. Shows a cluster of 5 black dots in the center of the target.</p>	<p>11: 9.5 →</p> <p>12: 9.4 →</p> <p>13: 10.0 →</p> <p>14: 9.4 ↑</p> <p>15: 8.8 ↓</p> <hr/> <p>Series 45.0</p> <p>Total 141.0</p>
--	---	--	---

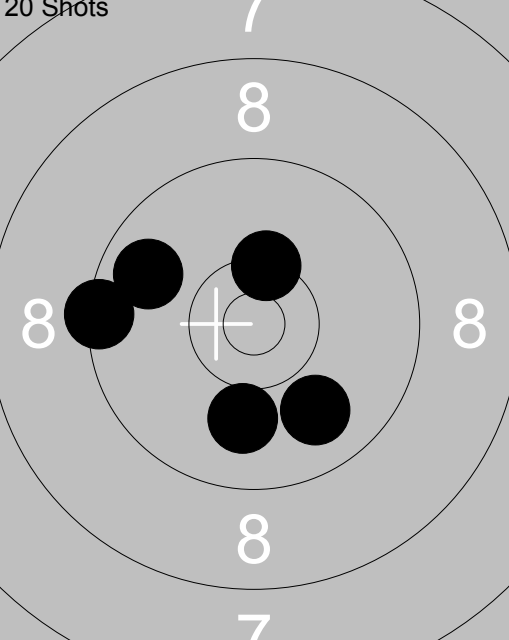
<p>20 Shots</p>  <p>Target diagram for 20 Shots. Shows a cluster of 5 black dots in the center of the target.</p>	<p>16: 10.0 ↓</p> <p>17: 9.4 ←</p> <p>18: 9.8 ←</p> <p>19: *10.4 ↑</p> <p>20: 9.9 ↓</p> <hr/> <p>Series 47.0</p> <p>Total 188.0</p>		
---	---	--	--

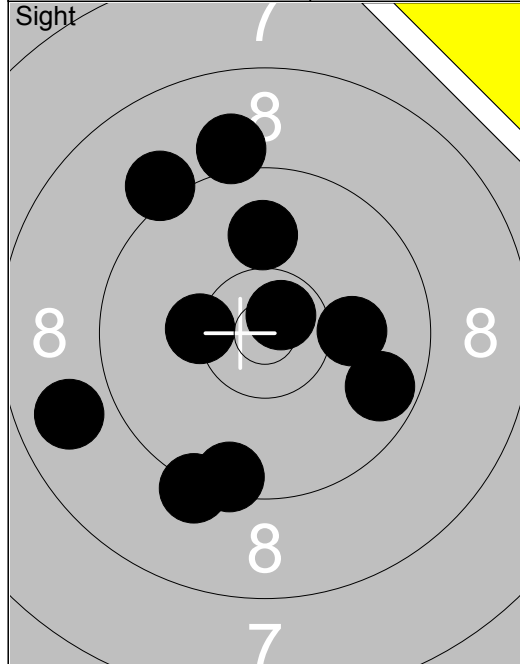

1:	8.8	←
2:	9.5	↓
3:	9.2	↓
4:	*10.3	←
5:	9.7	→
6:	*10.7	↗
7:	10.0	↑
8:	10.1	→
9:	9.1	↗
10:	9.1	↑
Series	93.0	
Total	0.0	

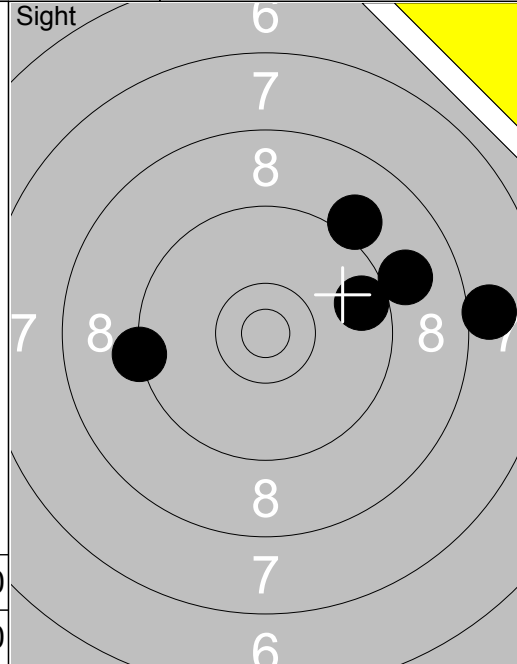

11:	9.6	→
12:	9.0	→
13:	8.0	→
14:	9.3	←
15:	9.1	↗
Series	44.0	
Total	0.0	

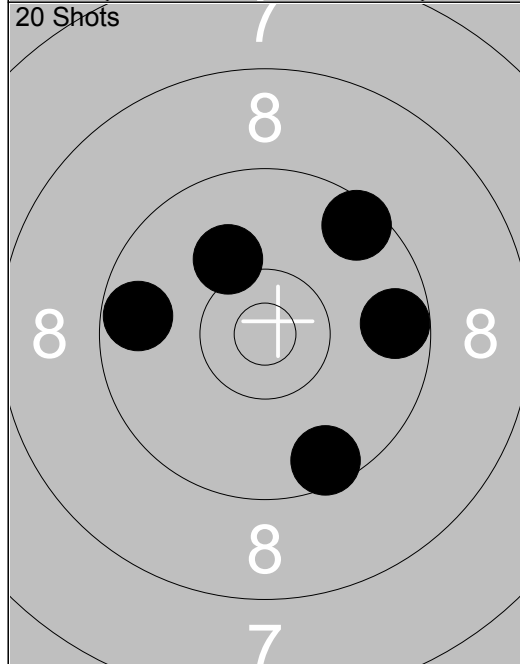

1:	9.5	↗
2:	9.6	↓
3:	9.7	→
4:	10.1	↗
5:	9.7	←
Series	46.0	
Total	46.0	

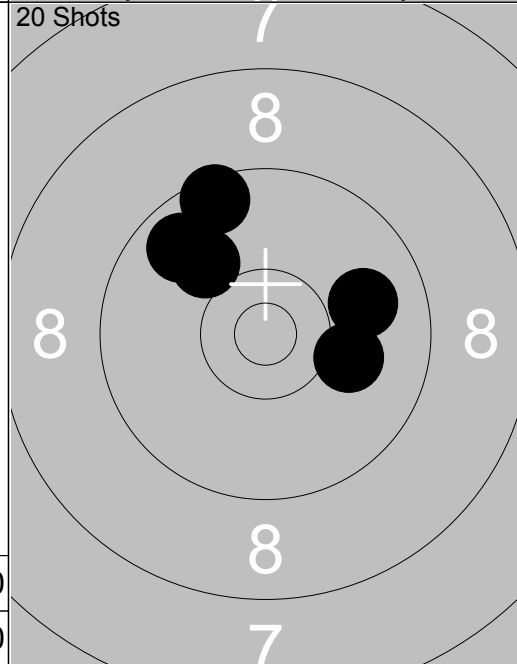

6:	9.5	↗
7:	9.7	↗
8:	9.9	→
9:	10.1	→
10:	10.0	↗
Series	47.0	
Total	93.0	

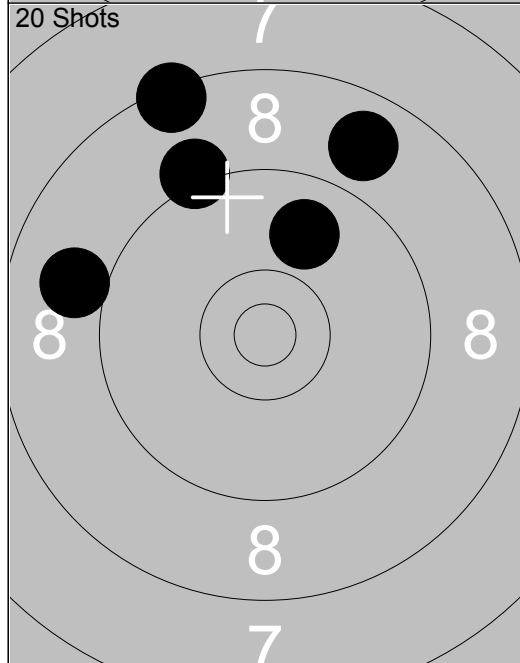

11:	9.9	↗
12:	9.2	↗
13:	9.0	←
14:	8.8	↗
15:	8.4	↗
Series	43.0	
Total	136.0	

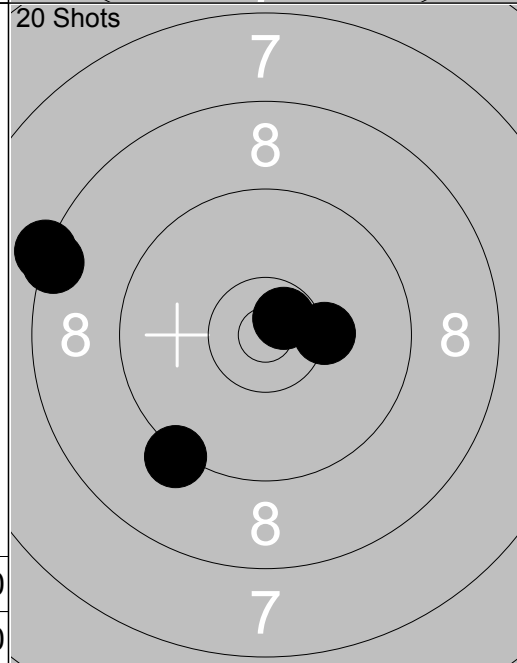

16:	10.3	→
17:	8.4	←
18:	*10.7	↗
19:	9.2	↓
20:	8.3	←
Series	45.0	
Total	181.0	



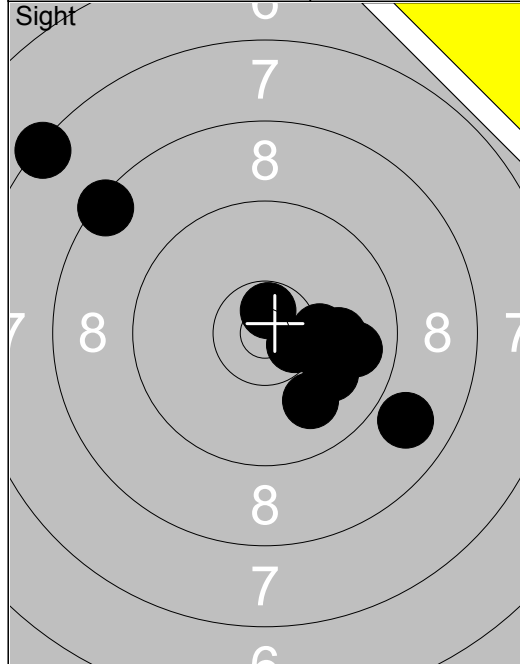

1: 7.4 ↖
2: 8.4 ↖
3: *10.6 ➡
4: 9.8 ➡
5: 10.3 ➡
6: *10.7 ↑
7: 10.0 ➡
8: 10.0 ➡
9: 8.9 ➡
10: 9.9 ↘
Series 91.0
Total 0.0

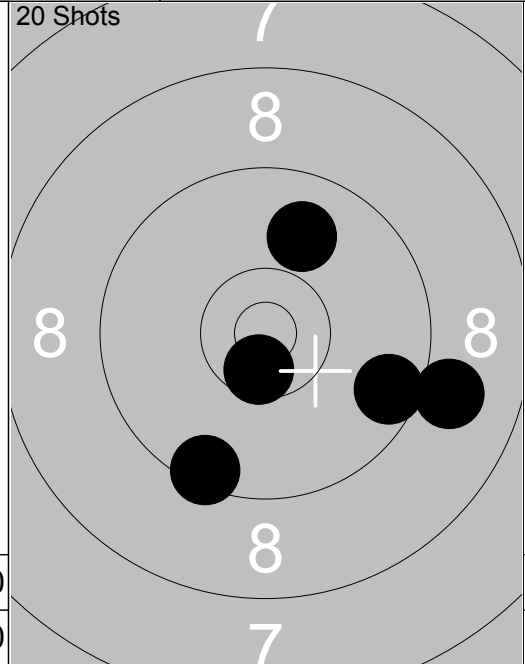

1: *10.6 ↘
2: 9.6 ➡
3: 9.0 ➡
4: 9.9 ↑
5: 9.5 ↘
Series 46.0
Total 46.0

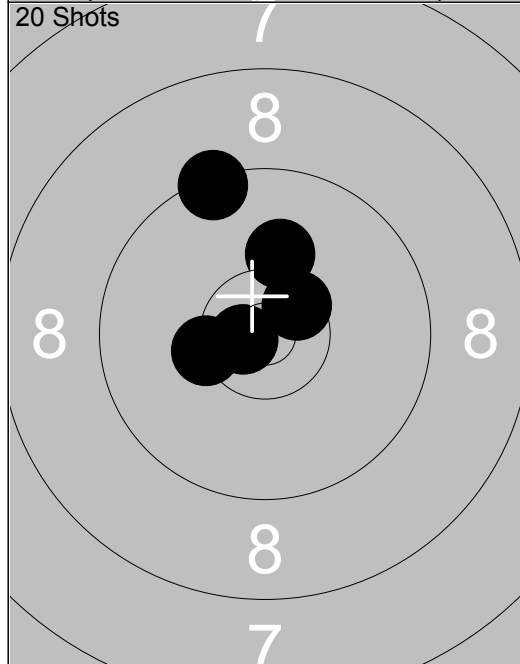

6: 10.1 ↑
7: 9.4 ↑
8: *10.7 ↖
9: *10.5 ↗
10: *10.3 ↖
Series 49.0
Total 95.0

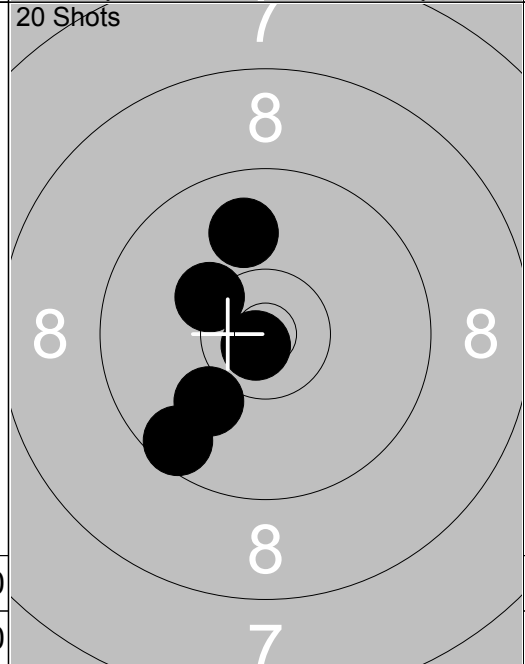

11: *10.8 ↘
12: 9.9 ↑
13: 9.6 ↘
14: 10.3 ↖
15: 10.1 ↘
Series 48.0
Total 143.0

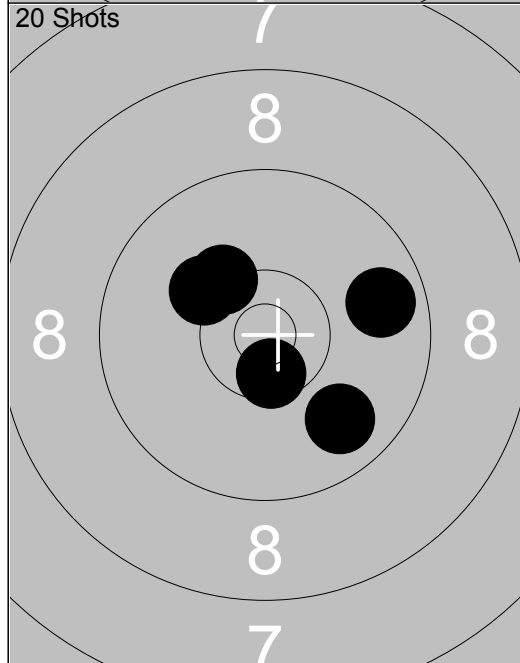

16: 9.7 ➡
17: *10.6 ↘
18: 9.8 ↘
19: 10.3 ↗
20: 10.2 ↖
Series 48.0
Total 191.0

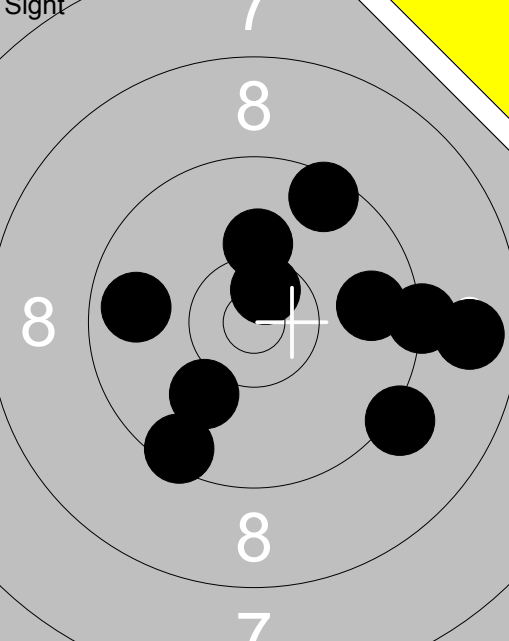
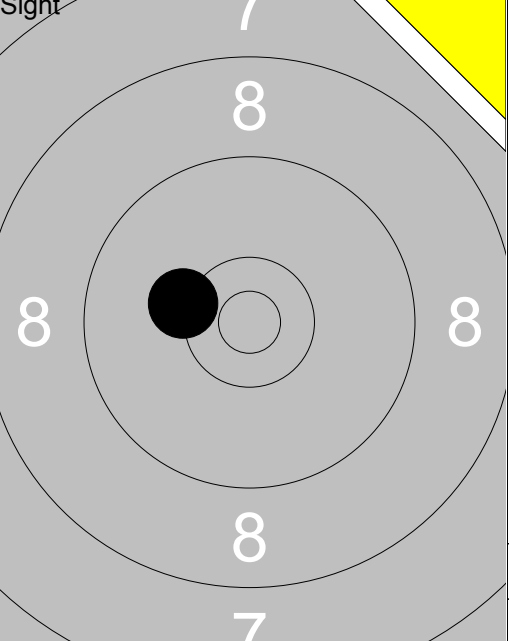
Sight		1: 8.8 →	Sight		11: 10.3 ←
		2: 9.3 →			Series
		3: 9.8 ←			
		4: 9.5 ↙			
		5: 9.2 ↘			
		6: *10.6 ↗			
		7: 9.8 →			
		8: 10.1 ↙			
		9: 10.2 ↑			
		10: 9.5 ↗			
		Series		Series	
		92.0		10.0	
		Total		Total	
		0.0		0.0	

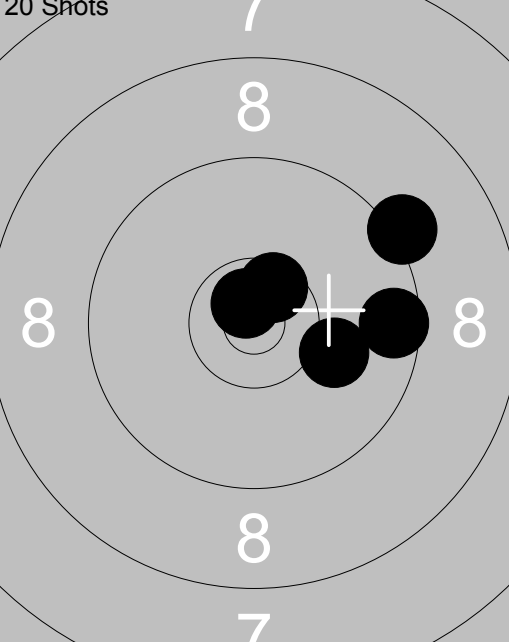
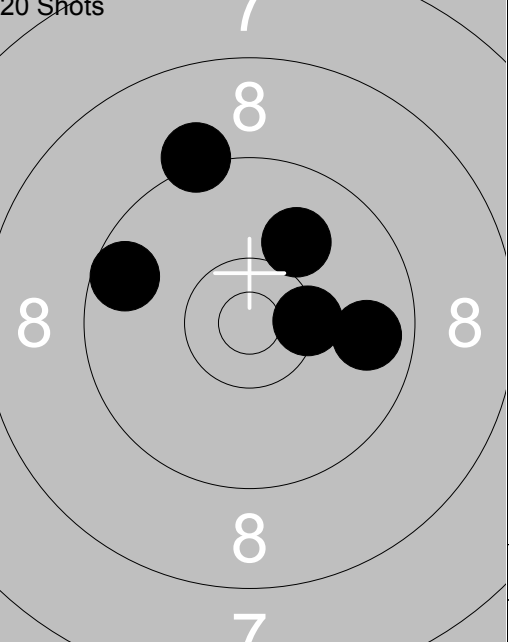
20 Shots		1: *10.5 ↗	20 Shots		6: *10.4 →
		2: *10.7 ↗			7: 10.0 ↗
		3: 10.1 →			8: 9.2 ↑
		4: 9.6 →			9: 9.6 ←
		5: 9.2 ↗			10: 9.8 →
		Series		Series	
		48.0		47.0	
		Total		Total	
		48.0		95.0	

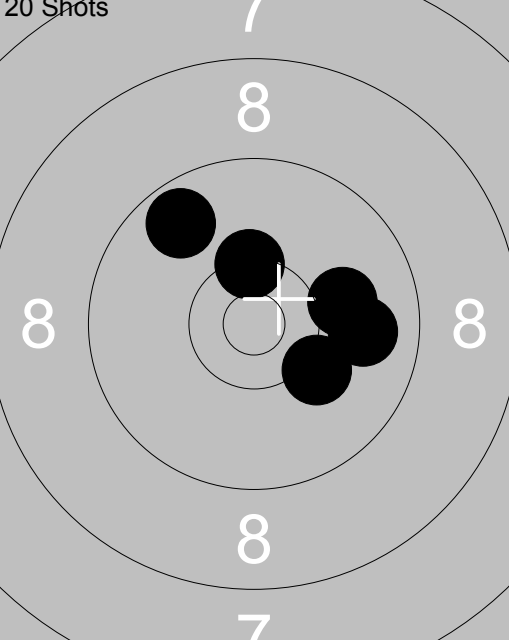
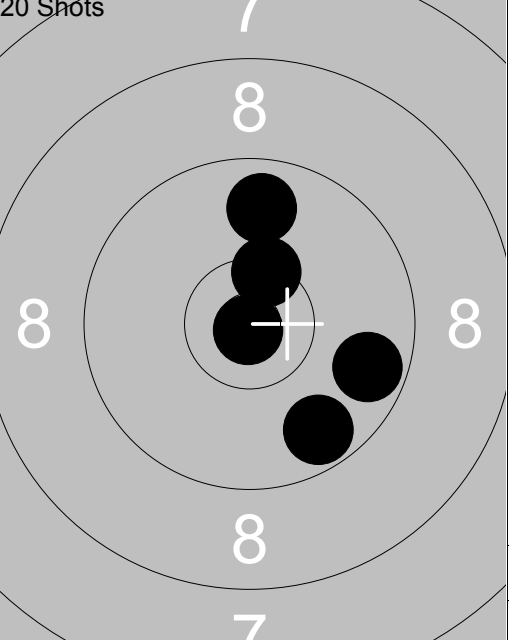
20 Shots		11: 9.7 ↙	20 Shots		16: *10.4 ↗
		12: *10.4 ↗			17: 9.7 ↘
		13: 10.2 ↘			18: *10.9 ↘
		14: 10.0 →			19: 9.7 →
		15: 9.9 →			20: 9.8 ↑
		Series		Series	
		48.0		47.0	
		Total		Total	
		143.0		190.0	

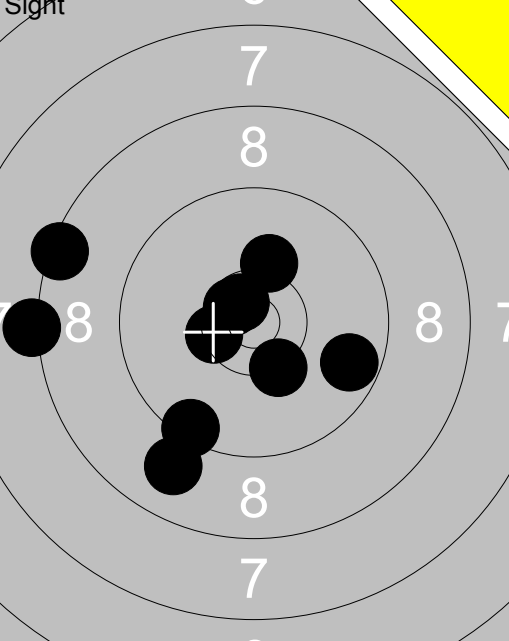
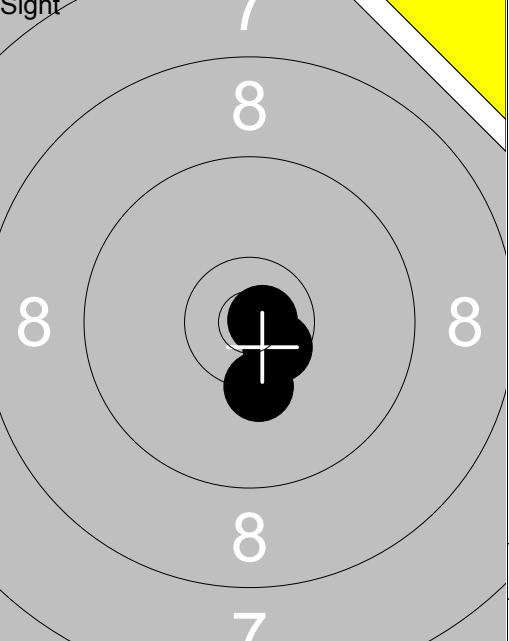
	1: 8.9 ↘ 2: 8.4 ← 3: 8.2 ← 4: 9.4 ↘ 5: 10.2 ↑ 6: *10.6 ↘ 7: 9.7 → 8: *10.7 ↘ 9: *10.4 ← 10: *10.3 ↘		11: *10.8 → 12: *10.6 ↘ 13: *10.3 ↘
	Series 92.0		Series 30.0
	Total 0.0		Total 0.0

	1: 9.9 ← 2: *10.5 ↘ 3: *10.5 ↘ 4: 8.8 → 5: *10.8 ↘		6: *10.4 ↘ 7: 10.3 ↘ 8: 9.3 ↘ 9: 10.2 ← 10: *10.5 ↑
	Series 47.0		Series 49.0
	Total 47.0		Total 96.0

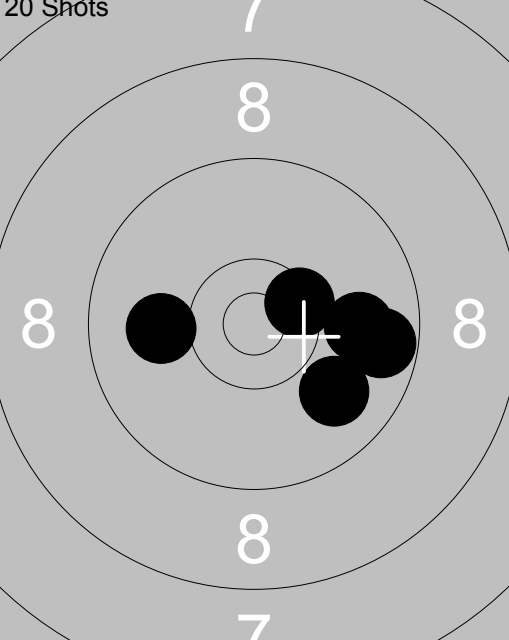
	11: 9.9 ↘ 12: *10.4 → 13: 10.0 ← 14: 9.7 → 15: 9.9 →	
	Series 47.0	
	Total 143.0	

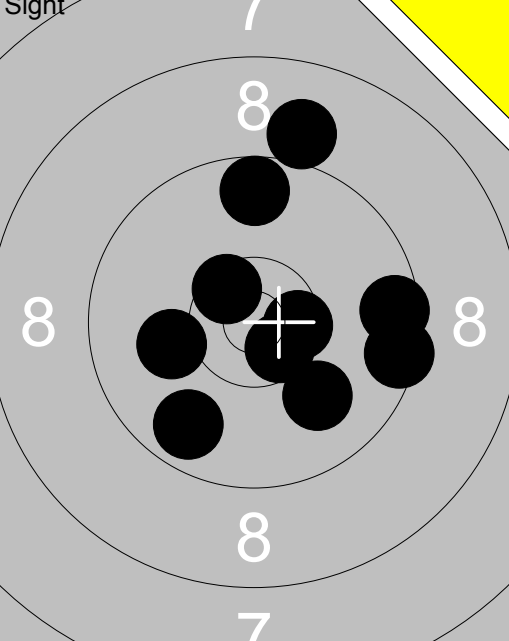
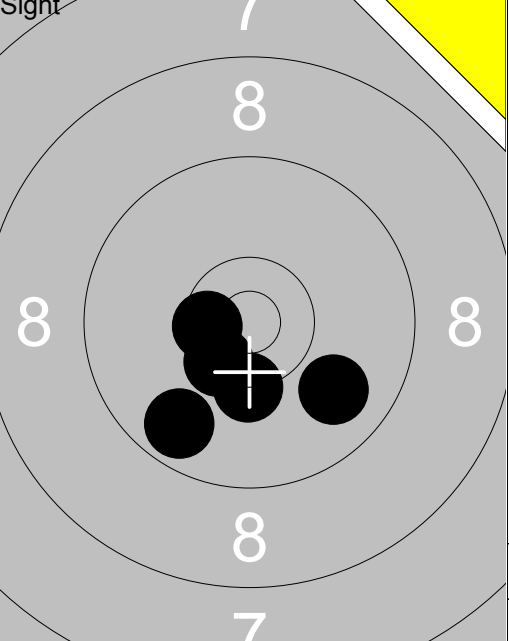
	1: 9.0 ↑		11: 9.9 ↘
	2: 9.6 ↑		12: *10.3 ↓
	3: *10.5 →		13: *10.5 ↘
	4: *10.6 ↘		14: *10.5 ↖
	5: 10.1 ←		15: 9.7 ↘
	6: 9.7 ↘		
	7: *10.5 ↘		
	8: 10.0 ↓		
	9: 9.5 →		
	10: 9.5 →		
Series	95.0	Series	48.0
Total	0.0	Total	0.0

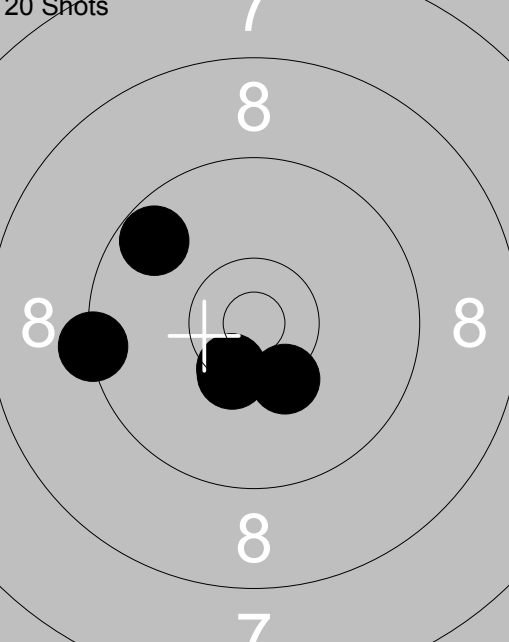
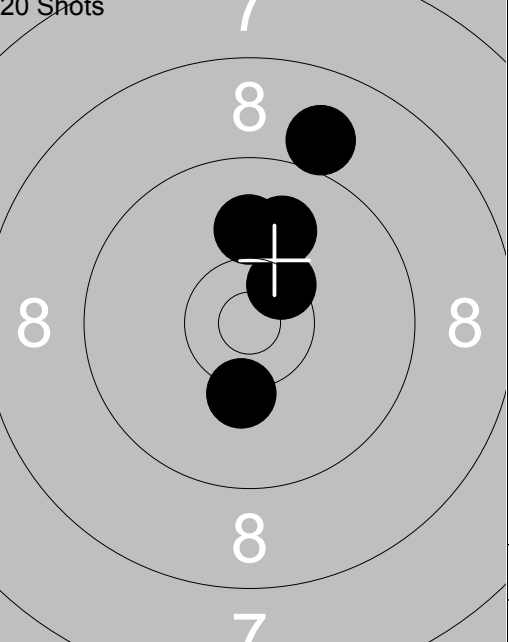
	1: *10.4 ↘		6: 10.2 ↓
	2: *10.3 ↘		7: 9.0 ↑
	3: *10.4 ↘		8: *10.5 ↗
	4: 9.3 ←		9: 10.0 ↑
	5: 9.7 ↖		10: 10.0 ↑
Series	48.0	Series	49.0
Total	48.0	Total	97.0

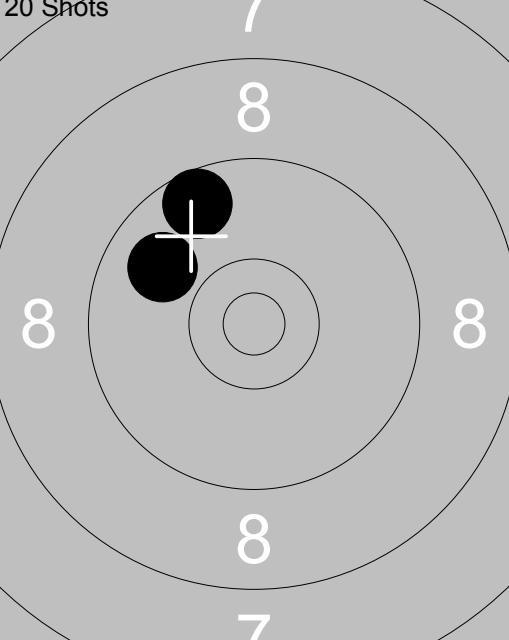
	11: 9.6 ↑	
	12: 9.9 ↖	
	Series	18.0
Total	115.0	

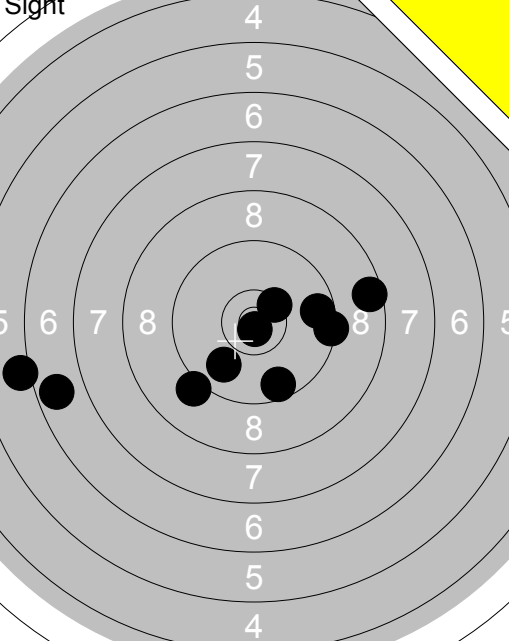
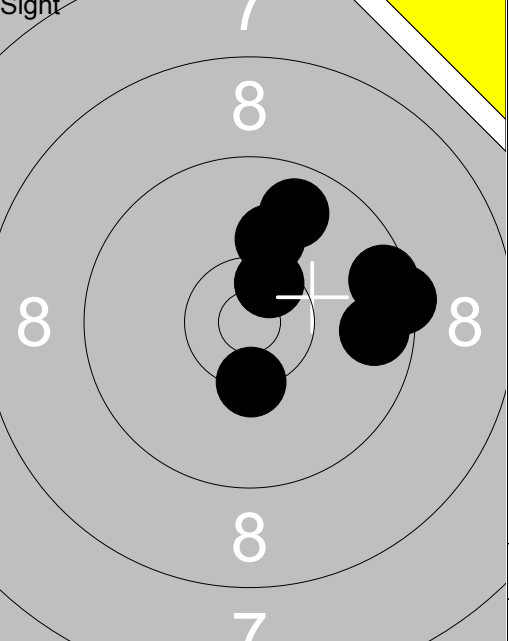
 <p>Sight</p>	<p>1: 6.1 ←</p> <p>2: 6.7 ←</p> <p>3: 9.1 ↙</p> <p>4: *10.4 ↗</p> <p>5: 9.6 →</p> <p>6: 8.6 →</p> <p>7: 9.4 →</p> <p>8: 9.9 ↘</p> <p>9: *10.8 ↓</p> <p>10: 9.6 ↓</p>	 <p>Sight</p>	<p>11: *10.4 ↓</p> <p>12: 9.4 →</p> <p>13: 9.7 →</p> <p>14: 9.8 ↗</p> <p>15: 10.1 ↗</p> <p>16: 9.6 →</p> <p>17: *10.5 ↗</p>
Series 85.0		Series 66.0	
Total 0.0		Total 0.0	

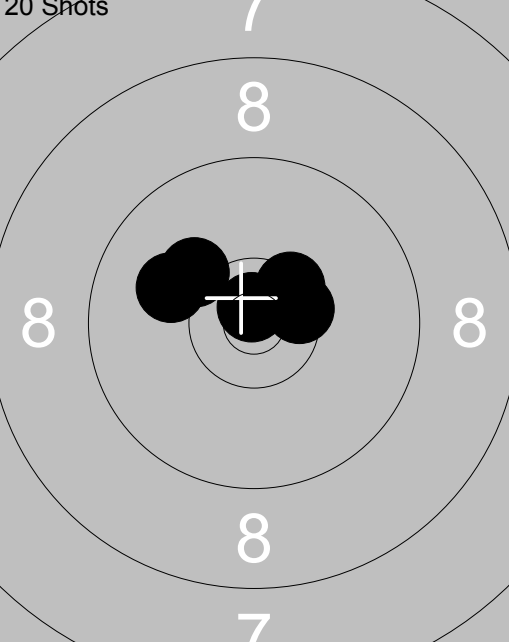
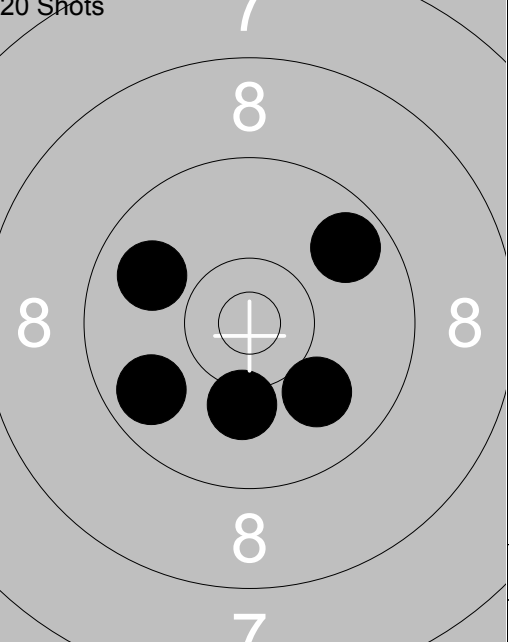
 <p>20 Shots</p>	<p>1: *10.4 ↗</p> <p>2: *10.5 →</p> <p>3: 10.0 ←</p> <p>4: *10.8 ↗</p> <p>5: 10.2 ↖</p>	 <p>20 Shots</p>	<p>6: 10.1 ↓</p> <p>7: 10.0 ↘</p> <p>8: 9.9 ←</p> <p>9: 9.8 ←</p> <p>10: 9.7 ↗</p>
Series 50.0		Series 47.0	
Total 50.0		Total 97.0	

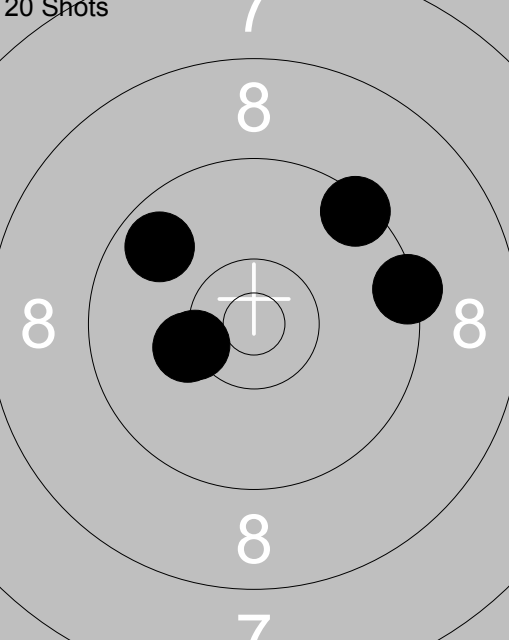
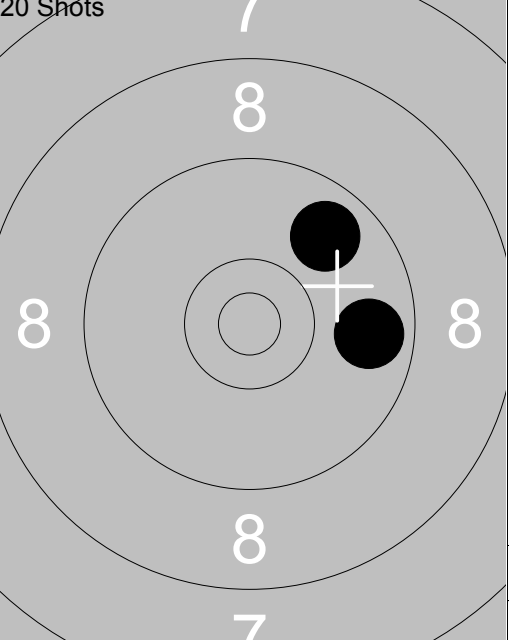
 <p>20 Shots</p>	<p>11: 9.4 →</p> <p>12: 10.2 ←</p> <p>13: 9.4 ↗</p> <p>14: 9.7 ↖</p> <p>15: *10.3 ←</p>	 <p>20 Shots</p>	<p>16: 9.8 →</p> <p>17: 9.8 ↗</p>
Series 47.0		Series 18.0	
Total 144.0		Total 162.0	

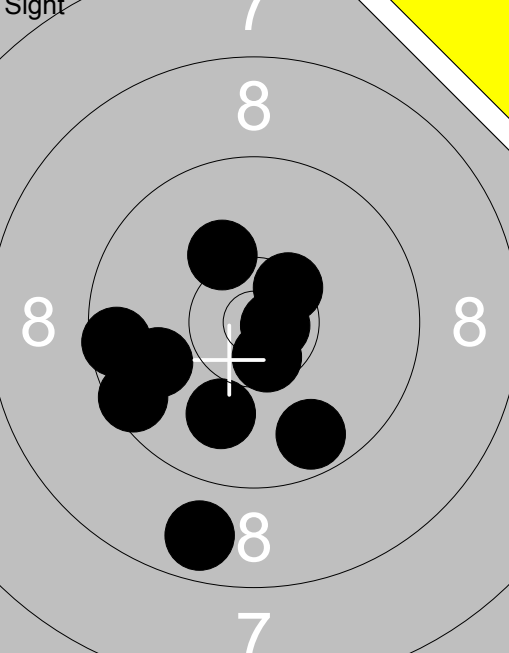
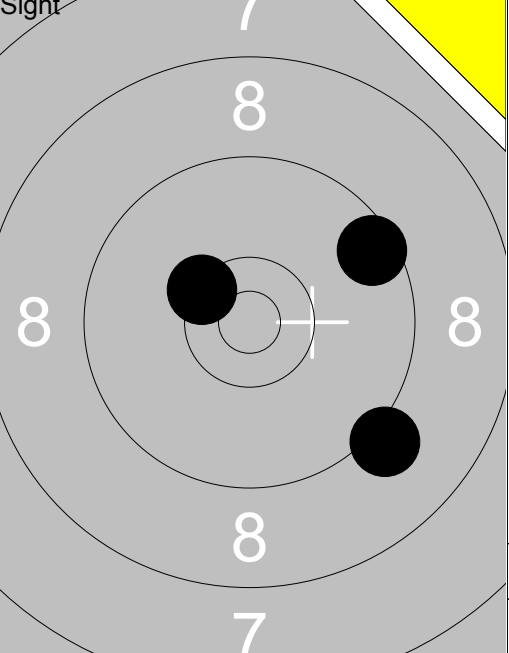
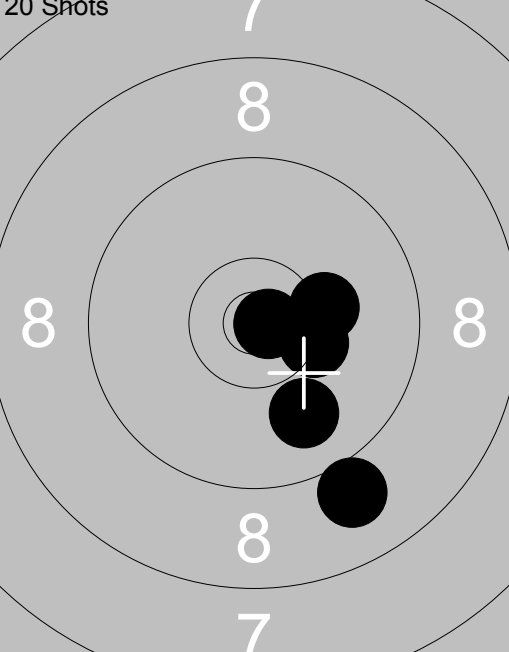
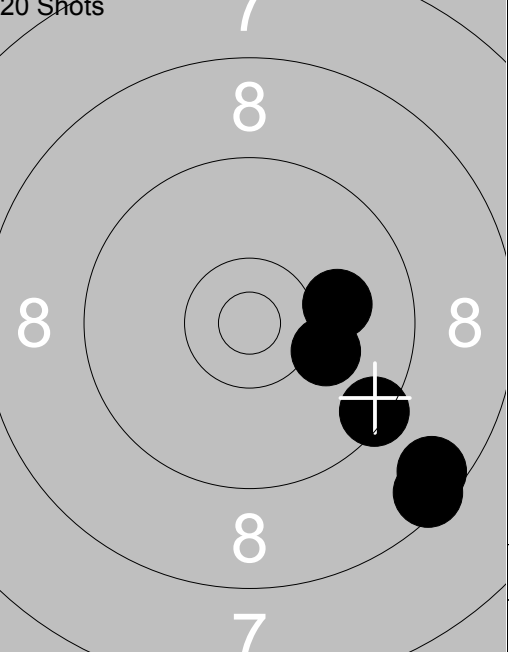
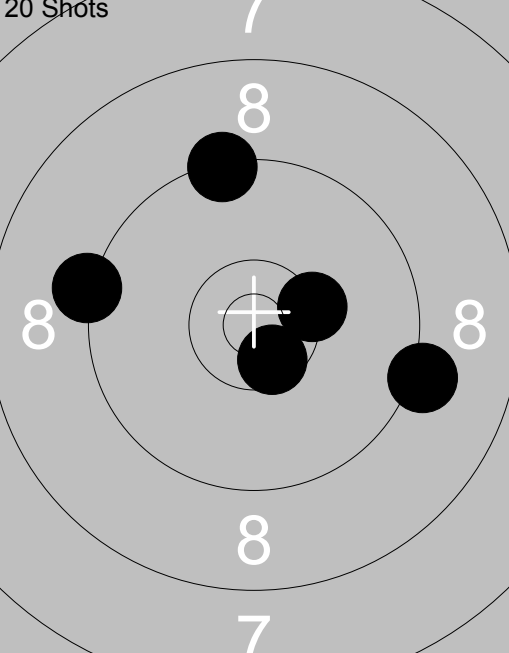
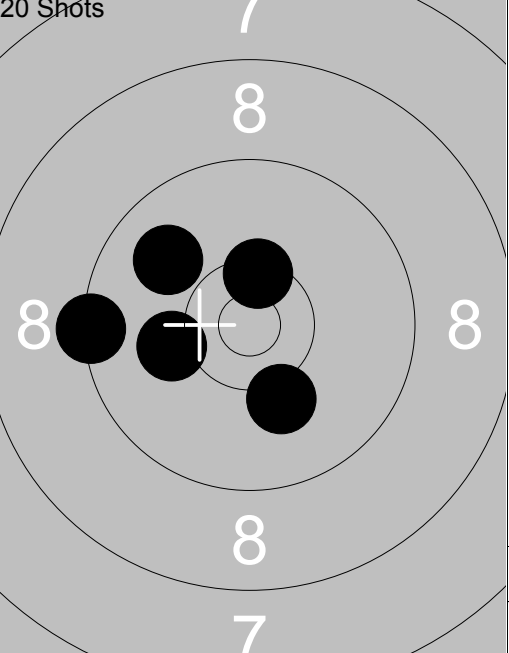
<p>Sight</p> 	<p>1: 9.6 ←                  2: 10.0 ↓                  3: *10.6 ↓                  4: 10.2 ↗                  5: *10.5 ↗                  6: 8.8 ↓                  7: 9.7 ↓                  8: 9.9 ←                  9: *10.7 →                  10: 9.5 ←</p> <p>Series 94.0 Total 0.0</p>	<p>Sight</p> 	<p>11: *10.4 ↖                  12: 9.5 ↗                  13: 9.2 ↓</p> <p>Series 28.0 Total 0.0</p>
<p>20 Shots</p> 	<p>1: 9.0 ↓                  2: 10.2 →                  3: *10.8 →                  4: *10.3 →                  5: 9.9 ↓</p> <p>Series 48.0 Total 48.0</p>	<p>20 Shots</p> 	<p>6: 8.6 ↓                  7: 8.5 ↓                  8: 9.4 ↓                  9: 10.1 →                  10: 10.1 →</p> <p>Series 45.0 Total 93.0</p>
<p>20 Shots</p> 	<p>11: 9.2 →                  12: *10.6 ↓                  13: 9.2 ←                  14: 9.3 ↑                  15: *10.3 →</p> <p>Series 47.0 Total 140.0</p>	<p>20 Shots</p> 	<p>16: *10.4 ↑                  17: 10.1 ↓                  18: 9.9 ↖                  19: 10.1 ←                  20: 9.4 ←</p> <p>Series 48.0 Total 188.0</p>

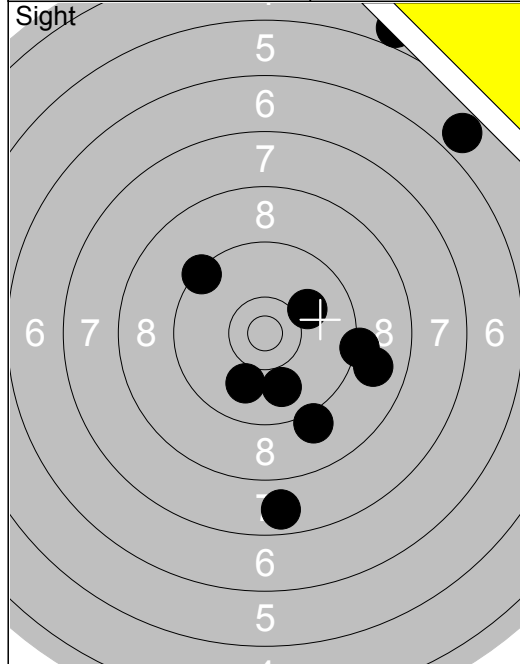

1:	4.9	↗
2:	5.9	↗
3:	9.2	→
4:	10.1	↗
5:	8.9	→
6:	9.9	↓
7:	7.8	↓
8:	9.1	↓
9:	10.0	↓
10:	9.4	↖
<b>Series</b>		<b>80.0</b>
<b>Total</b>		<b>0.0</b>

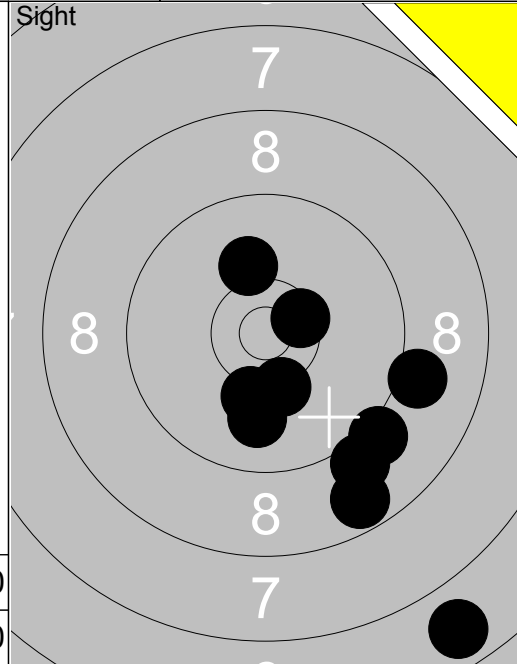

11:	9.9	↓
12:	8.7	↓
13:	9.0	↓
14:	9.1	↓
15:	*10.3	↓
16:	*10.5	↗
17:	10.1	↑
18:	6.8	↓
19:	10.2	↓
20:	9.1	→
<b>Series</b>		<b>90.0</b>
<b>Total</b>		<b>0.0</b>

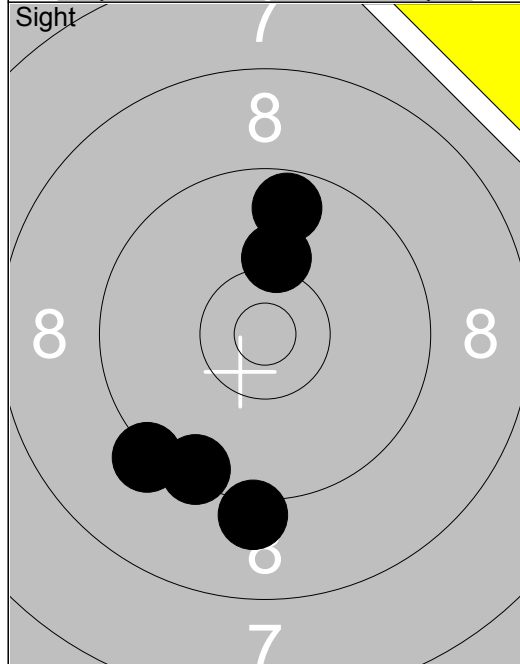

21:	9.4	↓
22:	9.2	↓
23:	9.7	↑
24:	9.1	↓
25:	10.2	↑
<b>Series</b>		<b>46.0</b>
<b>Total</b>		<b>0.0</b>

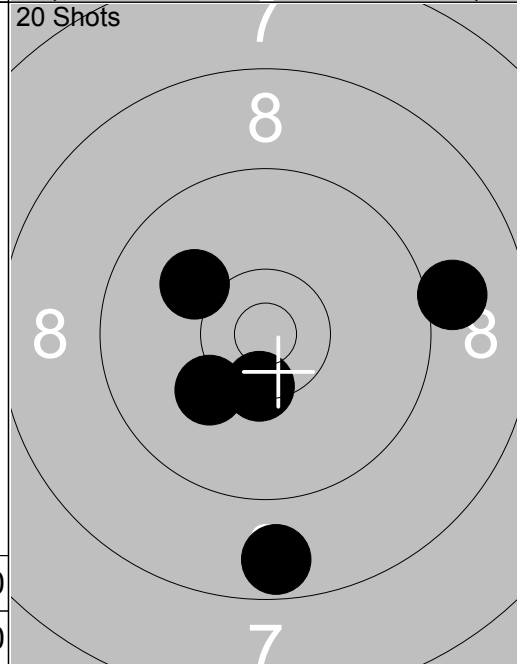

1:	10.1	↖
2:	10.2	↖
3:	*10.4	↓
4:	8.7	↓
5:	9.0	→
<b>Series</b>		<b>47.0</b>
<b>Total</b>		<b>47.0</b>

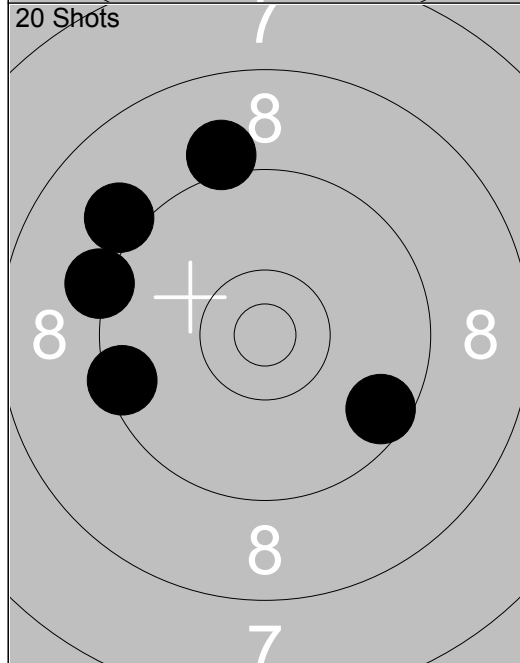

6:	9.5	←
7:	9.6	→
8:	9.1	↖
9:	9.1	↑
10:	9.2	←
<b>Series</b>		<b>45.0</b>
<b>Total</b>		<b>92.0</b>

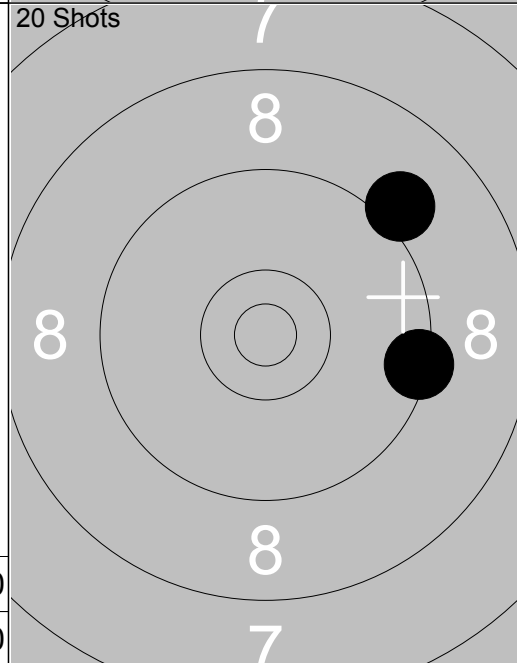

11:	9.1	↗
12:	9.4	→
<b>Series</b>		<b>18.0</b>
<b>Total</b>		<b>110.0</b>

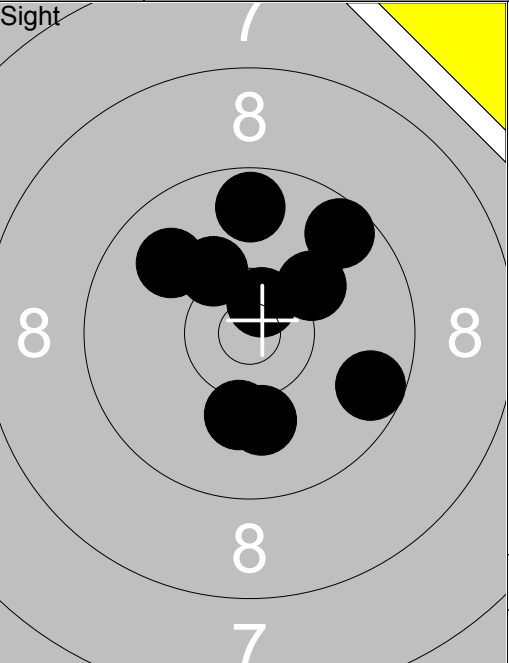
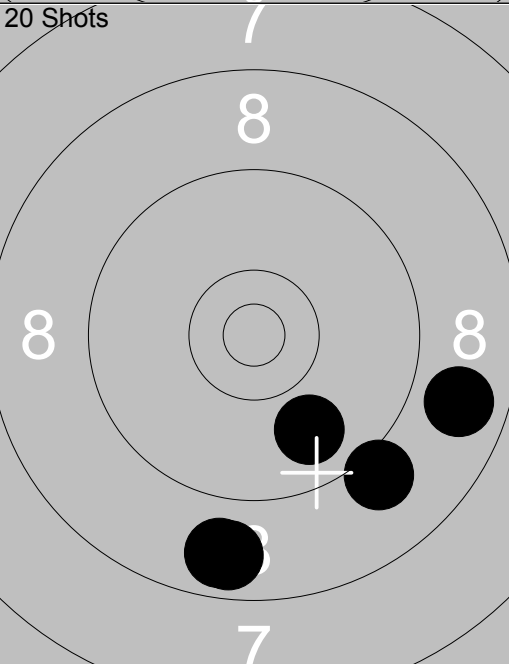
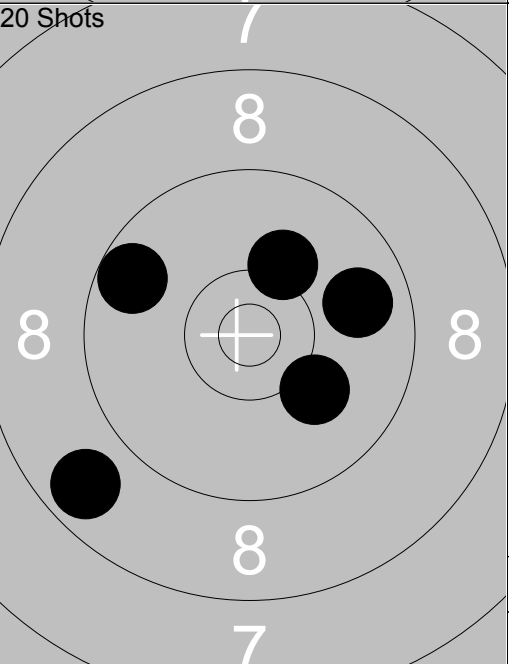
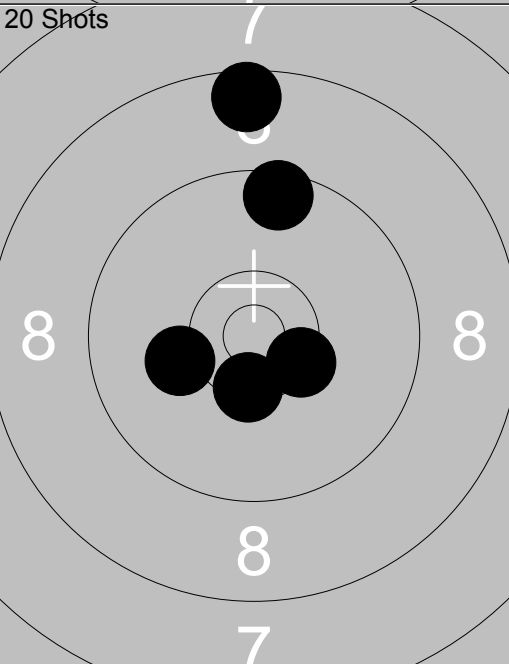
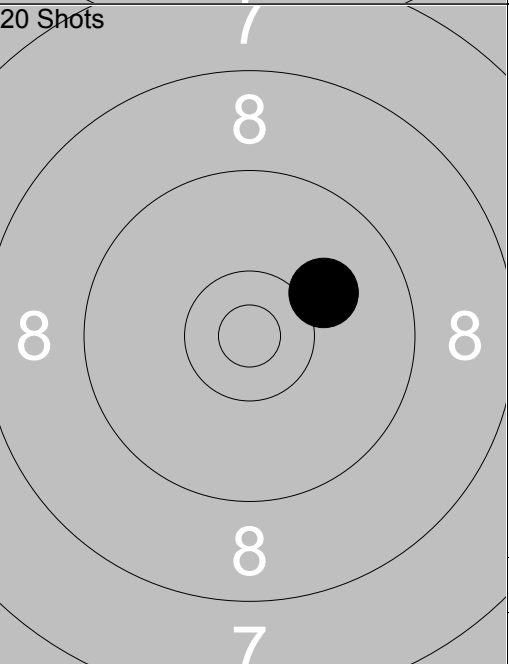
Relay	Lane	Ida Lundmark		
50m	Drängsmark	Sen-L	Vb	
08.07.2014	Tavelträffen Korthäll 2014	Ramselefors SKF		
Sight		1: 7.0 ↙ 2: 8.5 ↓ 3: 5.8 ↙ 4: 8.6 ↓ 5: 7.5 ↓ 6: 7.9 ↓ 7: 9.8 ↓ 8: *10.7 ↓ 9: 8.5 ↓ 10: 8.8 ↓ Series 77.0 Total 0.0	Sight 	11: *10.6 ↗ 12: 10.1 ↓ 13: 10.1 ↓ 14: 9.9 ↖ 15: 10.2 ↖ 16: 9.6 ↗ 17: 9.6 → 18: 10.2 ↗ 19: 9.7 ↑ Series 86.0 Total 0.0
20 Shots		1: 9.1 ↓ 2: 8.8 → 3: 9.9 ↓ 4: 8.7 ↓ 5: 8.7 ↓ Series 42.0 Total 42.0	20 Shots 	6: 8.7 ↙ 7: 9.7 ↖ 8: 9.8 → 9: 10.2 ↗ 10: 10.1 ↓ Series 46.0 Total 88.0
20 Shots		11: 8.6 ↑ 12: *10.4 ↓ 13: 10.2 ↖ 14: 9.5 ↑ 15: *10.4 ↘ Series 47.0 Total 135.0	20 Shots 	16: 10.1 ↗ Series 10.0 Total 145.0



--	--

--	--

--	--

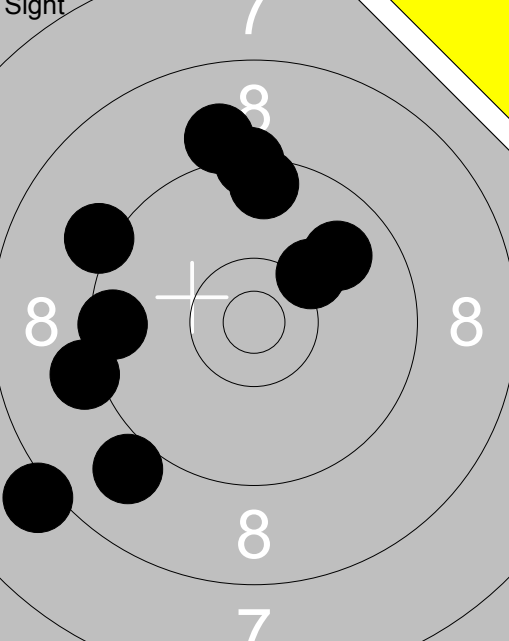
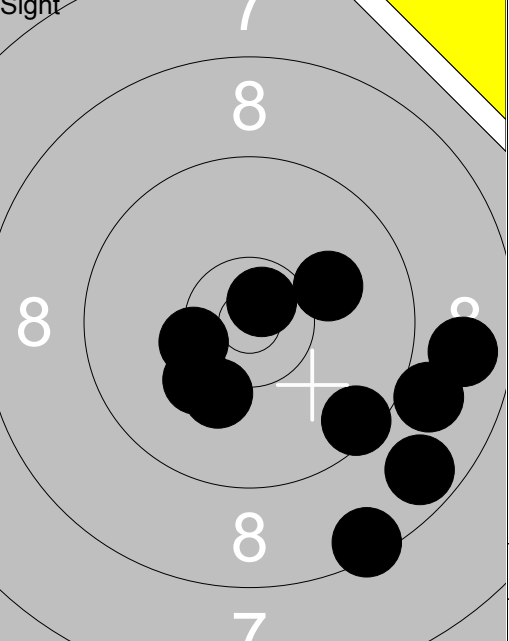
	1: 9.0 ↙		11: 10.2 ↘
	2: 9.2 ←		12: *10.4 ↙
	3: 9.2 ↖		13: 8.7 ↘
	4: 9.3 ↑		14: 8.8 →
	5: 9.1 ↑		15: 10.1 ↗
	6: 9.5 ↑		16: 8.5 ↘
	7: 9.9 ↗		17: 9.0 →
	8: 8.1 ↙		18: 9.5 ↘
	9: 10.2 ↗		19: *10.7 ↗
	10: 9.5 ←		20: 10.2 ↙
Series	90.0	Series	92.0
Total	0.0	Total	0.0

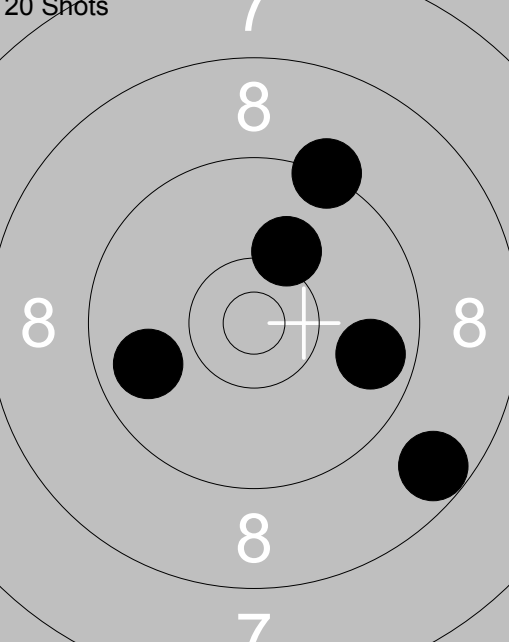
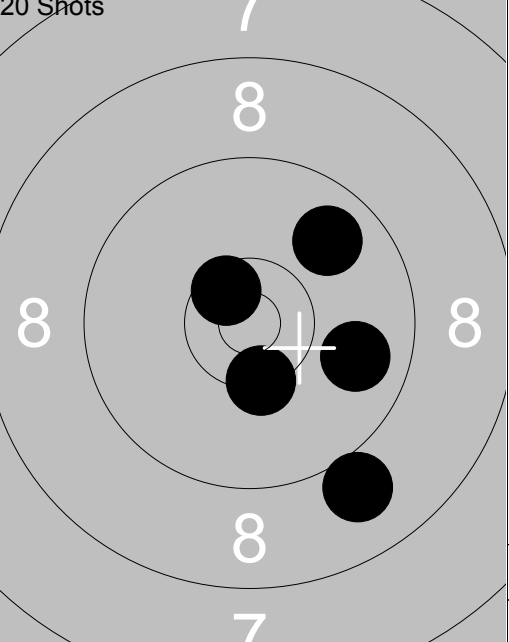
	1: 8.7 ↘		6: 9.0 ↘
	2: 9.8 ←		7: *10.4 ↘
	3: 10.2 ↗		8: 9.8 →
	4: 9.3 ↗		9: *10.6 ↖
	5: 9.7 →		10: 9.8 ↗
Series	45.0	Series	47.0
Total	45.0	Total	92.0

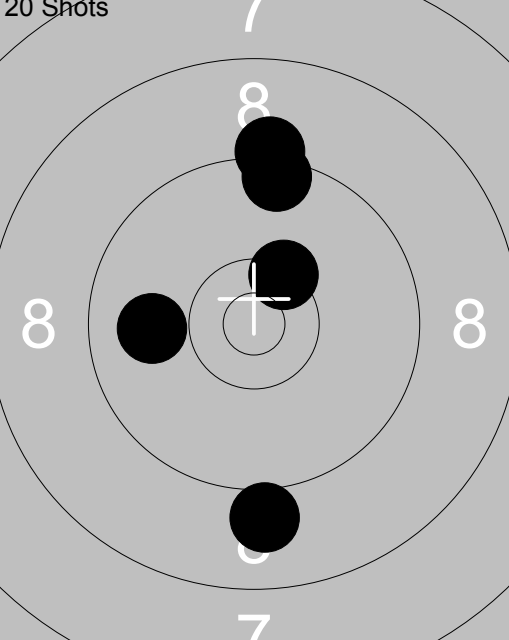
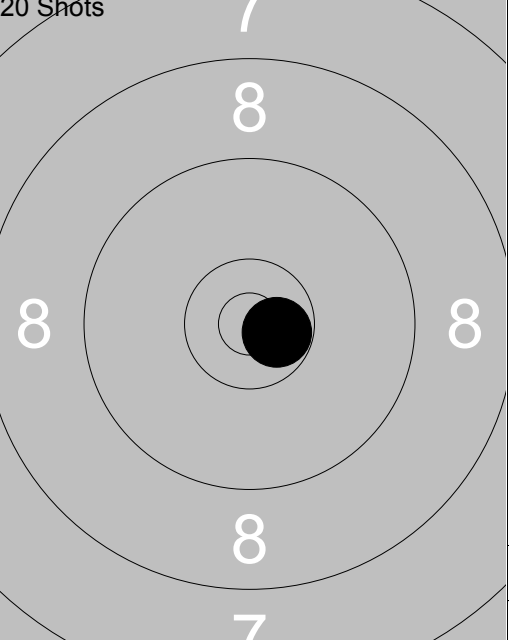
	11: *10.4 ↗		16: *10.7 ↗
	12: 9.5 ↑		
	13: 9.2 ↑		
	14: 9.0 ↓		
	15: 9.9 ←		
Series	46.0	Series	10.0
Total	138.0	Total	148.0

<p>Sight</p>	<p>Sight</p>
--------------	--------------

<p>20 Shots</p>	<p>20 Shots</p>
-----------------	-----------------

<p>20 Shots</p>	<p>20 Shots</p>
-----------------	-----------------

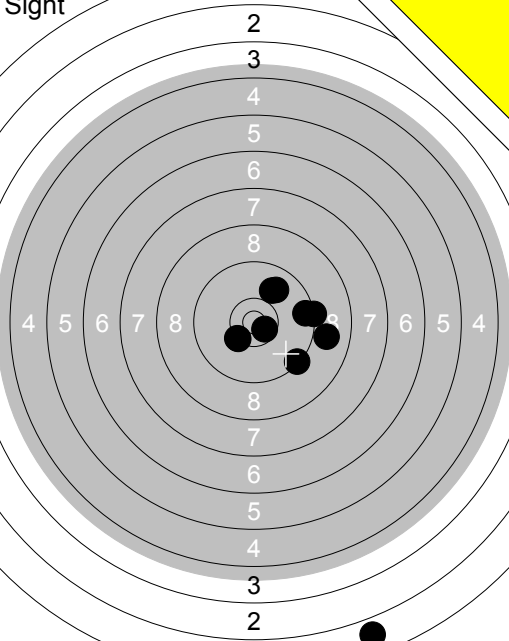
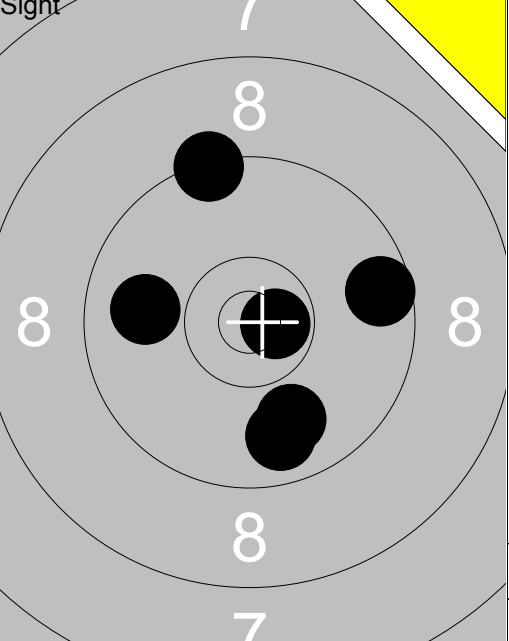
	<p>1: 1.8 ↓</p> <p>2: 9.3 →</p> <p>3: 9.5 →</p> <p>4: 8.9 →</p> <p>5: *10.3 ↘</p> <p>6: *10.6 ↘</p> <p>7: 9.9 ↗</p> <p>8: *10.3 ↘</p> <p>9: 9.4 ↘</p> <p>10: 9.9 ↗</p>		<p>11: 9.3 ↗</p> <p>12: 9.9 ↓</p> <p>13: *10.7 →</p> <p>14: 9.9 ←</p> <p>15: 9.6 →</p> <p>16: 9.8 ↓</p>
Series 84.0		Series 55.0	
Total 0.0		Total 0.0	

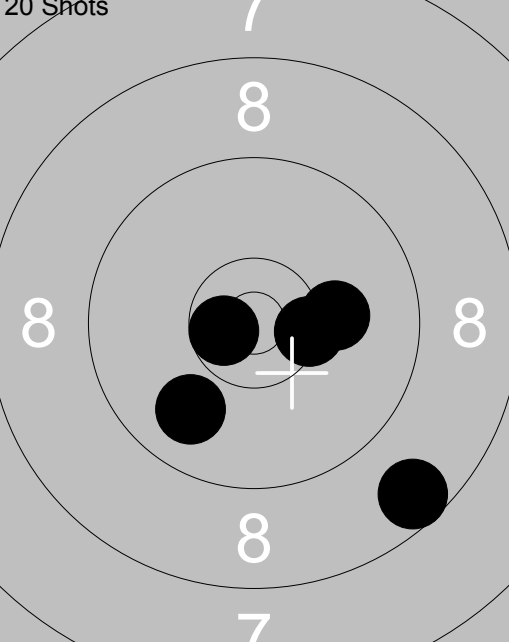
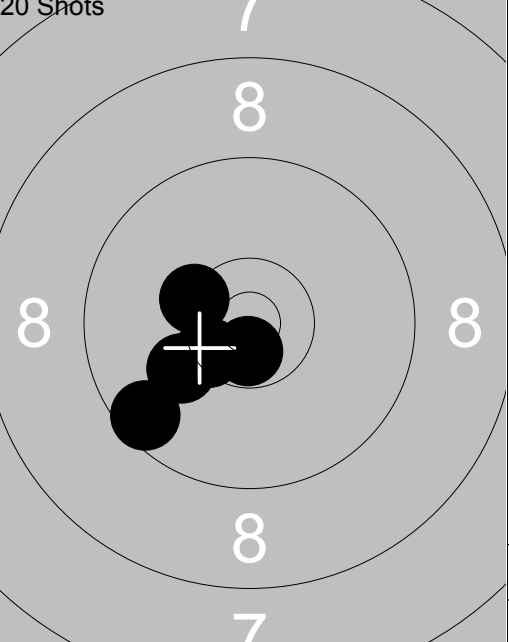
<p>20 Shots</p> 	<p>1: *10.4 →</p> <p>2: 9.9 ↓</p> <p>3: 8.6 ↓</p> <p>4: *10.6 ←</p> <p>5: 10.1 →</p>	<p>20 Shots</p> 	<p>6: *10.4 ↘</p> <p>7: *10.4 ↘</p> <p>8: *10.7 ↓</p> <p>9: 9.6 ←</p> <p>10: 10.1 ↘</p>
Series 47.0		Series 49.0	
Total 47.0		Total 96.0	

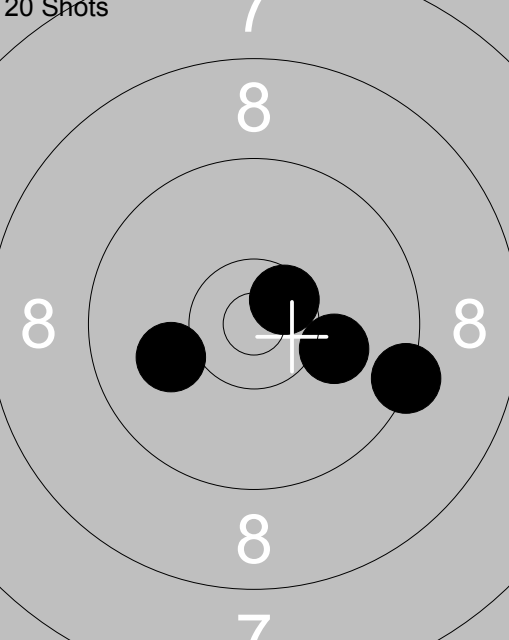
<p>20 Shots</p> 	<p>11: 10.1 ←</p> <p>12: 10.1 →</p> <p>13: *10.6 ↗</p> <p>14: 9.3 →</p>		
Series 39.0			
Total 135.0			

<p>Sight</p>	<p>Sight</p>	
<p>20 Shots</p>	<p>20 Shots</p>	<p>Series 82.0</p> <p>Total 0.0</p>
<p>20 Shots</p>	<p>20 Shots</p>	<p>Series 47.0</p> <p>Total 47.0</p>
<p>Series 48.0</p> <p>Total 140.0</p>	<p>Series 45.0</p> <p>Total 92.0</p>	<p>Series 46.0</p> <p>Total 186.0</p>

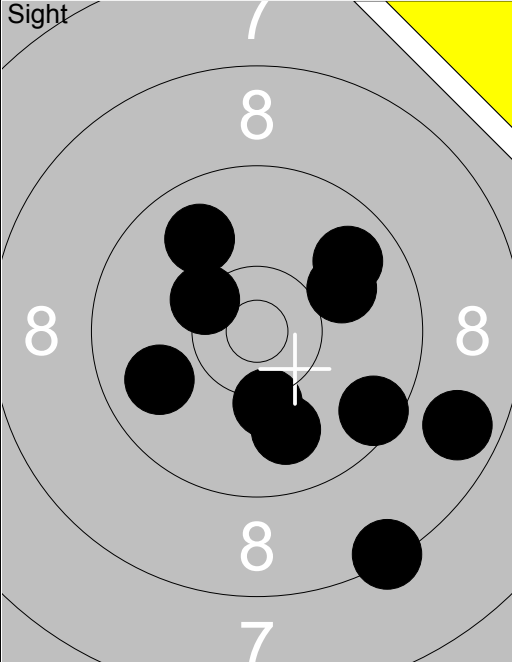
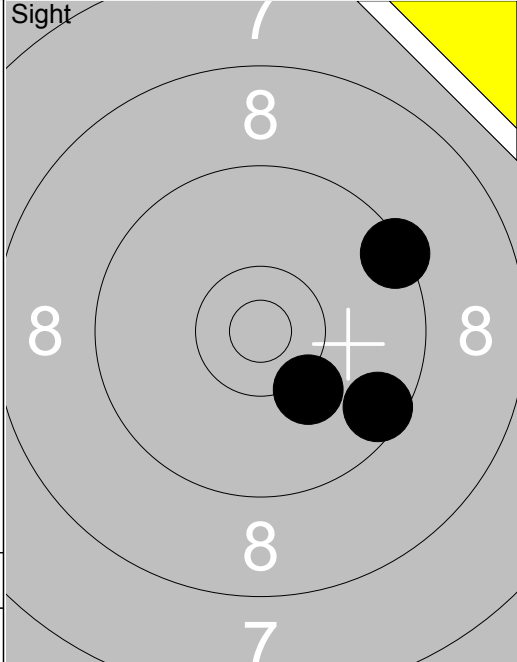
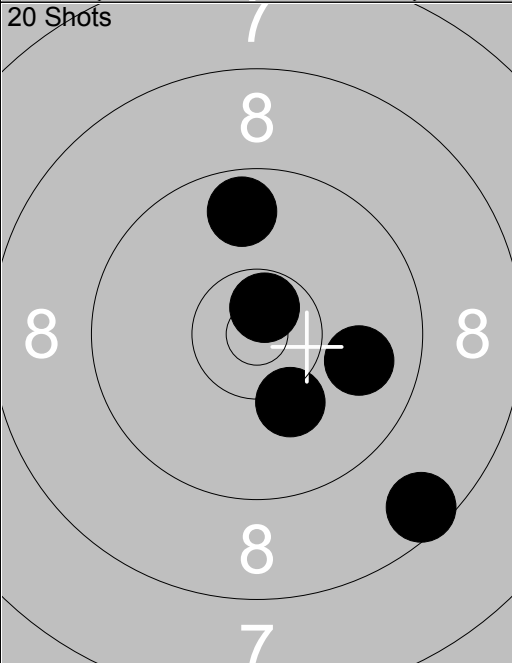
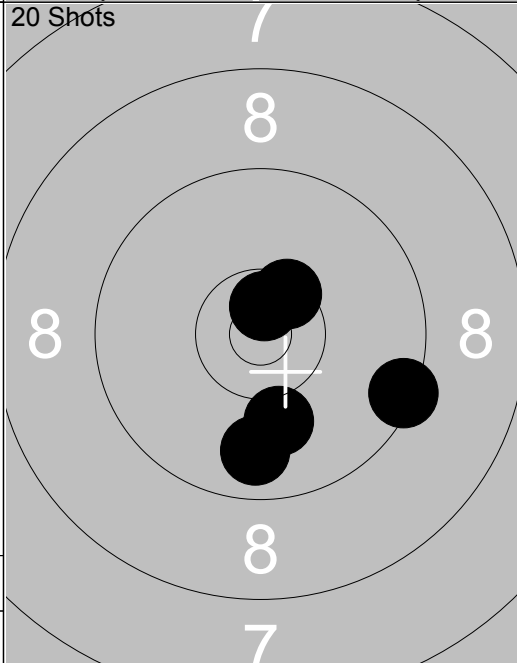
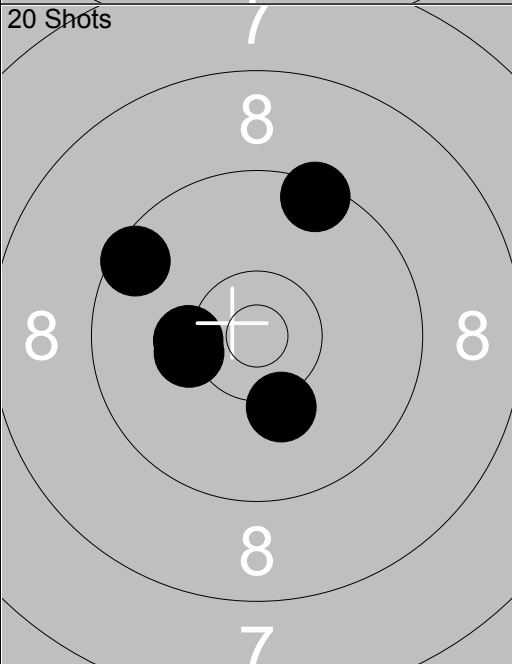
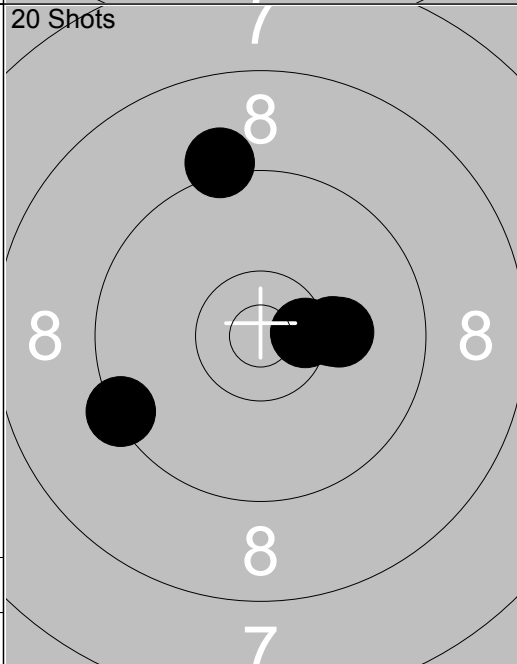
<p>Sight</p> 	<p>1: 8.4 ↘                  2: 9.9 ↙                  3: 9.8 ↗                  4: 10.2 ↓                  5: 9.9 ↗                  6: 8.7 →                  7: 9.9 ↓                  8: 9.5 ↓                  9: *10.3 ↘                  10: 10.0 ↗</p> <p>Series 91.0                  Total 0.0</p>	<p>Sight</p> 	<p>11: 9.4 ↗                  12: 10.2 ↓                  13: 9.6 ↓</p> <p>Series 28.0                  Total 0.0</p>
<p>20 Shots</p> 	<p>1: 10.2 ↓                  2: 9.9 →                  3: 9.7 ↑                  4: 8.6 ↓                  5: *10.7 ↑</p> <p>Series 46.0                  Total 46.0</p>	<p>20 Shots</p> 	<p>6: 9.4 →                  7: 9.8 ↓                  8: *10.5 ↗                  9: *10.7 ↑                  10: 10.1 ↓</p> <p>Series 48.0                  Total 94.0</p>
<p>20 Shots</p> 	<p>11: 10.2 ↓                  12: 10.2 ←                  13: 10.3 ←                  14: 9.5 ↙                  15: 9.4 ↗</p> <p>Series 48.0                  Total 142.0</p>	<p>20 Shots</p> 	<p>16: 10.2 →                  17: *10.5 →                  18: 9.2 ↑                  19: 10.2 →                  20: 9.4 ↙</p> <p>Series 48.0                  Total 190.0</p>

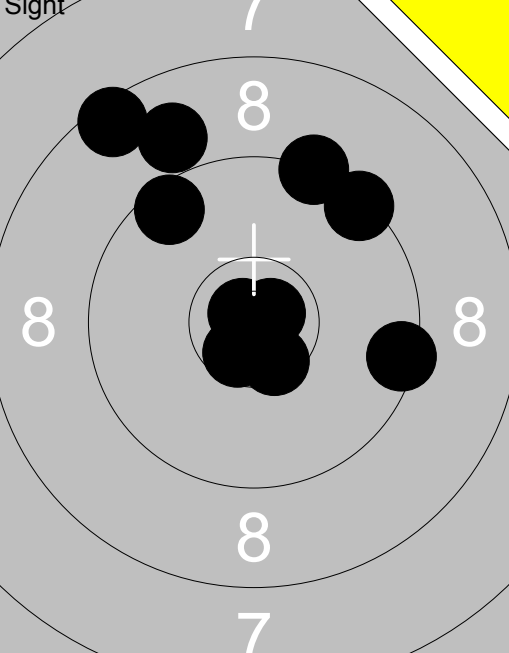
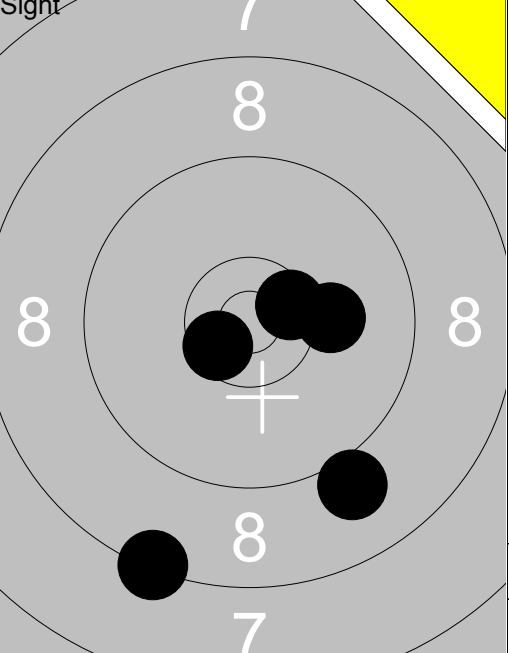
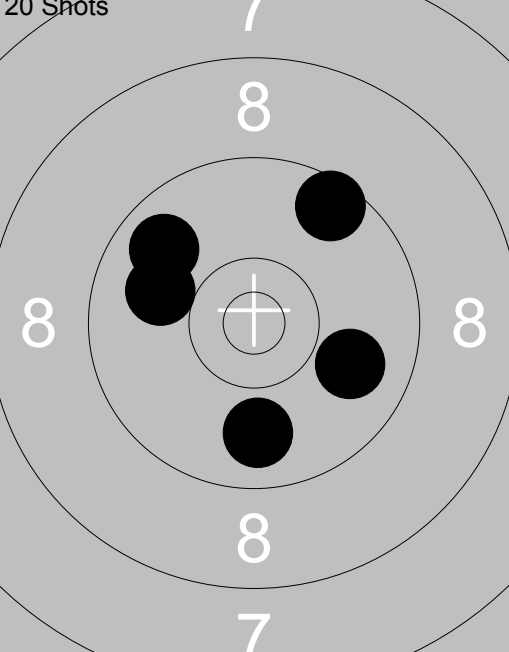
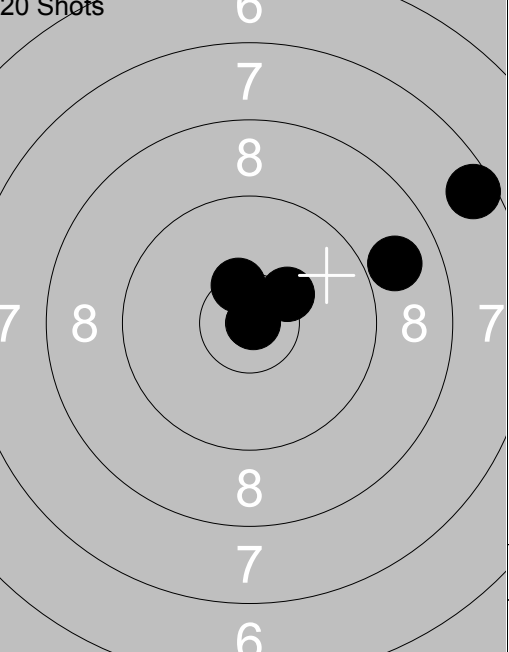
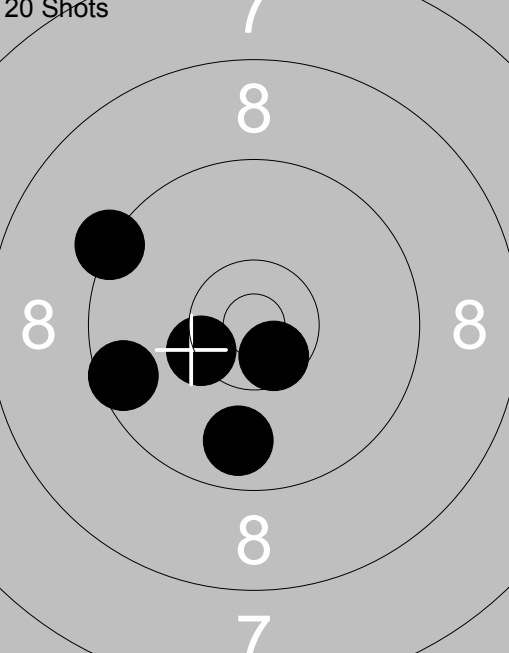
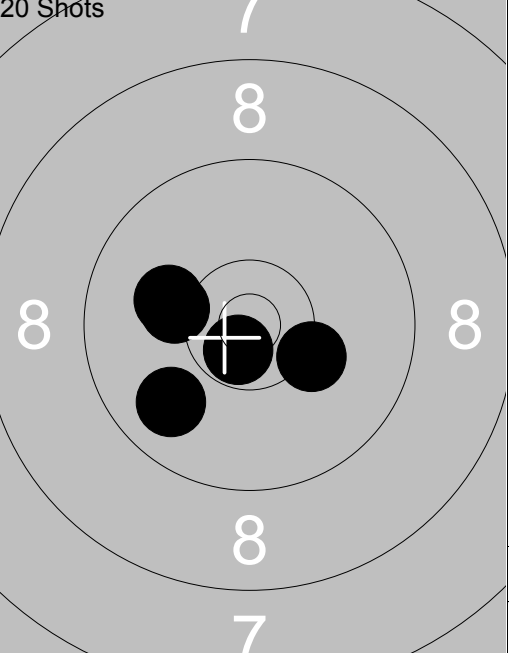
<p>Sight</p> 	<p>1: 8.5 ↖                  2: 8.9 ↖                  3: 9.5 ↖                  4: 9.4 ↗                  5: 9.3 ↖                  6: *10.8 ↖                  7: 9.4 →                  8: *10.5 ↘                  9: *10.6 ↘                  10: *10.8 ↗</p> <p>Series 92.0 Total 0.0</p>	<p>Sight</p> 	<p>11: *10.5 ↗                  12: 8.3 ↘                  13: 10.1 →                  14: 9.0 ↘                  15: *10.6 ↘</p> <p>Series 47.0 Total 0.0</p>
<p>20 Shots</p> 	<p>1: 9.9 ↓                  2: 9.9 →                  3: 10.0 ↖                  4: 9.6 ↖                  5: 9.8 ↖</p> <p>Series 46.0 Total 46.0</p>	<p>20 Shots</p> 	<p>6: *10.3 ↗                  7: 7.6 ↗                  8: *10.9 →                  9: *10.4 ↖                  10: 8.9 →</p> <p>Series 45.0 Total 91.0</p>
<p>20 Shots</p> 	<p>11: 9.8 ↓                  12: *10.6 ↘                  13: *10.4 ↘                  14: 9.6 ←                  15: 9.3 ↖</p> <p>Series 47.0 Total 138.0</p>	<p>20 Shots</p> 	<p>16: 10.1 ↖                  17: 9.9 ↘                  18: 10.2 ↖                  19: *10.7 ↘                  20: 10.3 →</p> <p>Series 49.0 Total 187.0</p>

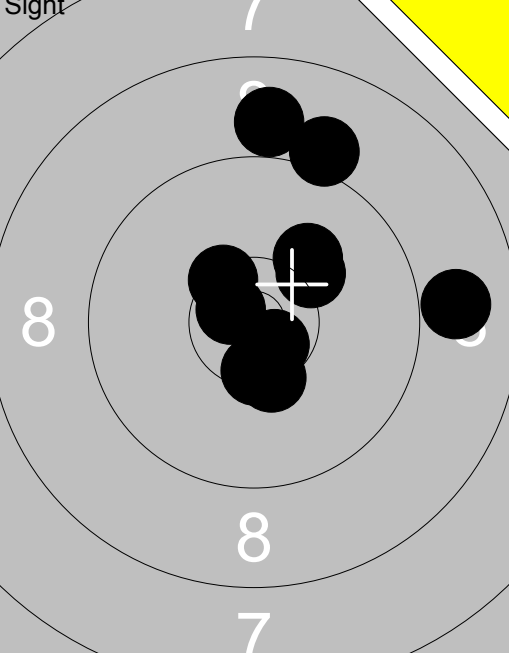
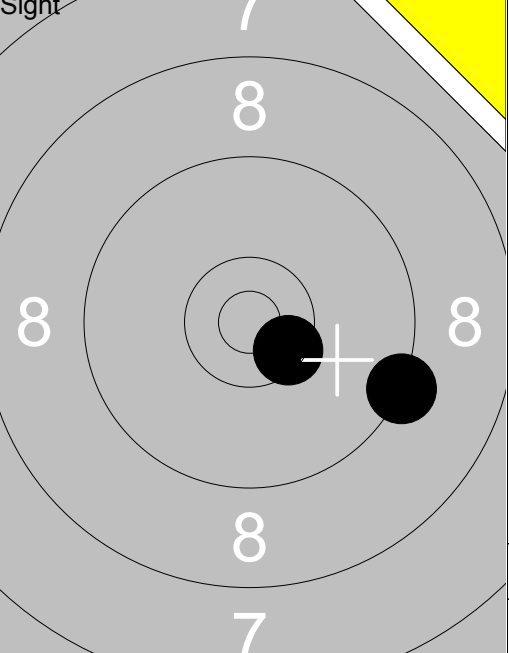
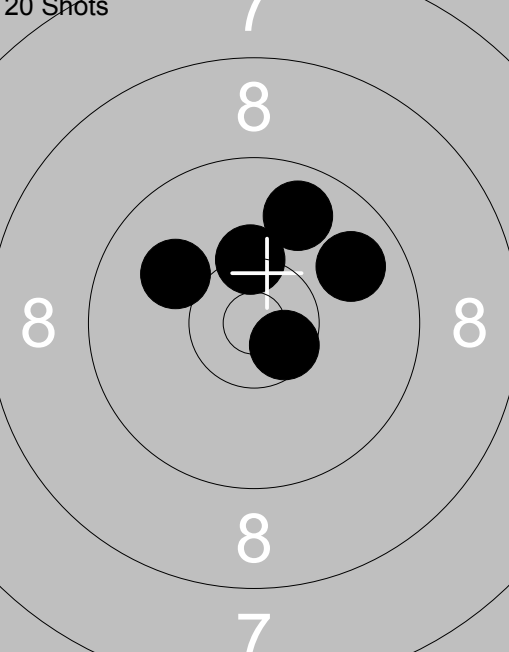
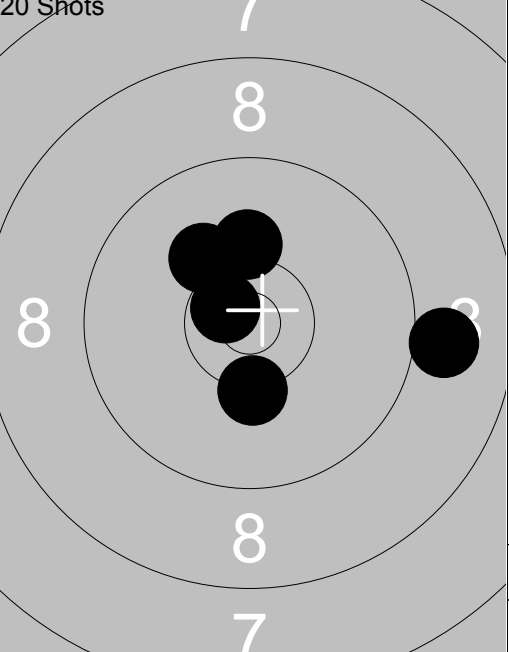
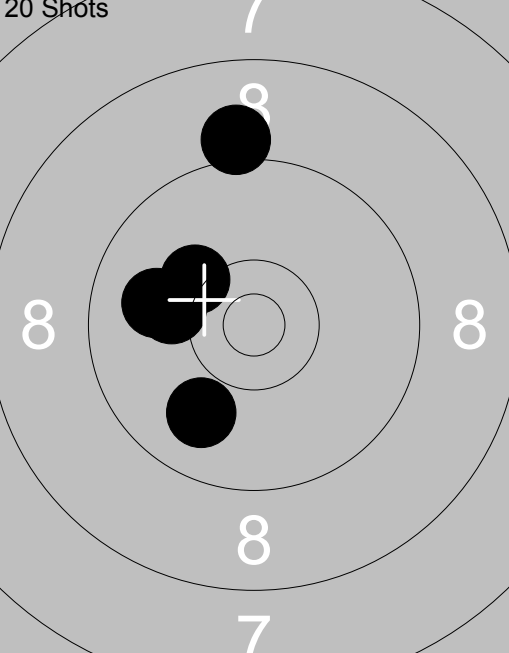
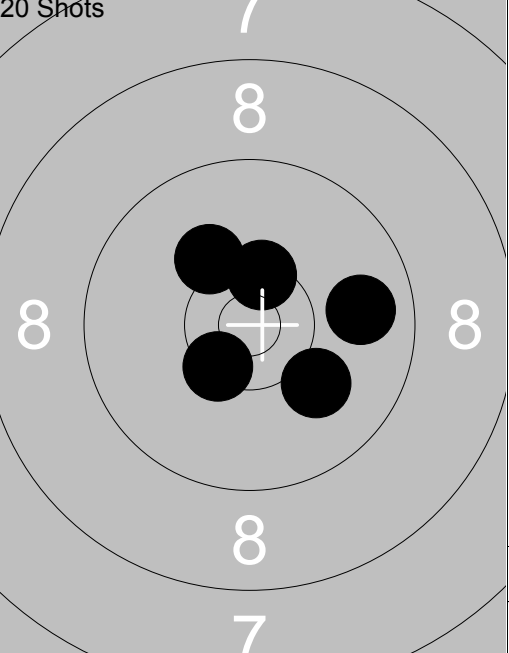

<p>Sight</p>  <p style="text-align: center;">8 7</p>	<p>1: 8.9 → 2: 8.9 ↑ 3: 10.1 ↗ 4: *10.4 ↓ 5: 10.2 ↗ 6: *10.4 ↖ 7: *10.5 ↓ 8: *10.7 ↖ 9: 9.1 ↑ 10: *10.7 ↘</p> <table border="1" style="width:100%; border-collapse: collapse;"> <tr><td>Series</td><td>95.0</td></tr> <tr><td>Total</td><td>0.0</td></tr> </table>	Series	95.0	Total	0.0	<p>Sight</p>  <p style="text-align: center;">8 7</p> <p>11: 9.3 → 12: *10.5 ↘</p> <table border="1" style="width:100%; border-collapse: collapse;"> <tr><td>Series</td><td>19.0</td></tr> <tr><td>Total</td><td>0.0</td></tr> </table>	Series	19.0	Total	0.0
Series	95.0									
Total	0.0									
Series	19.0									
Total	0.0									
<p>20 Shots</p>  <p style="text-align: center;">8 7</p>	<p>1: 9.8 ↗ 2: 10.0 ↖ 3: *10.6 ↘ 4: *10.3 ↑ 5: 9.8 ↑</p> <table border="1" style="width:100%; border-collapse: collapse;"> <tr><td>Series</td><td>48.0</td></tr> <tr><td>Total</td><td>48.0</td></tr> </table>	Series	48.0	Total	48.0	<p>20 Shots</p>  <p style="text-align: center;">8 7</p> <p>6: 10.3 ↓ 7: 9.0 → 8: 10.2 ↖ 9: *10.7 ↖ 10: 10.2 ↑</p> <table border="1" style="width:100%; border-collapse: collapse;"> <tr><td>Series</td><td>49.0</td></tr> <tr><td>Total</td><td>97.0</td></tr> </table>	Series	49.0	Total	97.0
Series	48.0									
Total	48.0									
Series	49.0									
Total	97.0									
<p>20 Shots</p>  <p style="text-align: center;">8 7</p>	<p>11: 10.0 ← 12: 10.2 ↖ 13: 9.1 ↑ 14: 9.9 ↓ 15: 10.1 ←</p> <table border="1" style="width:100%; border-collapse: collapse;"> <tr><td>Series</td><td>48.0</td></tr> <tr><td>Total</td><td>145.0</td></tr> </table>	Series	48.0	Total	145.0	<p>20 Shots</p>  <p style="text-align: center;">8 7</p> <p>16: *10.4 ↘ 17: *10.4 ↑ 18: 9.8 → 19: 10.1 ↘ 20: 10.2 ↖</p> <table border="1" style="width:100%; border-collapse: collapse;"> <tr><td>Series</td><td>49.0</td></tr> <tr><td>Total</td><td>194.0</td></tr> </table>	Series	49.0	Total	194.0
Series	48.0									
Total	145.0									
Series	49.0									
Total	194.0									

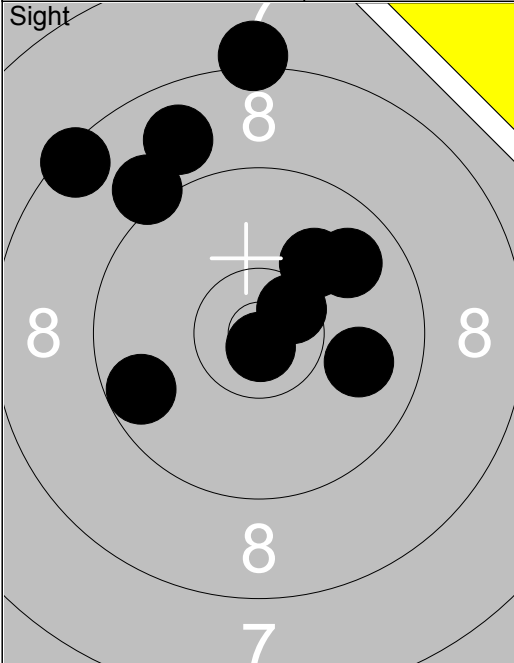
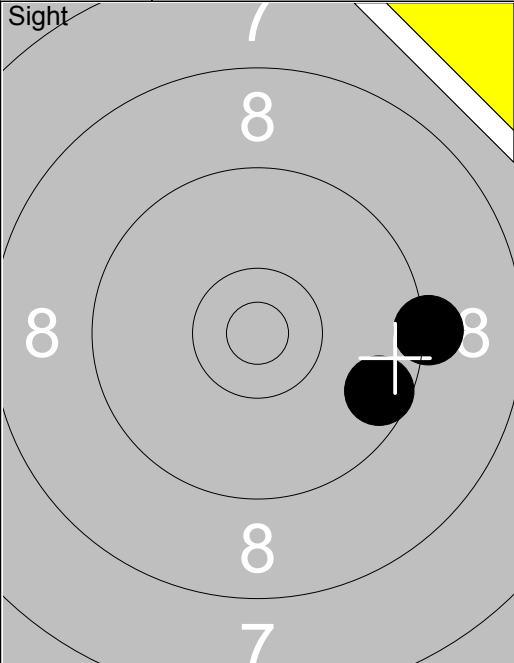
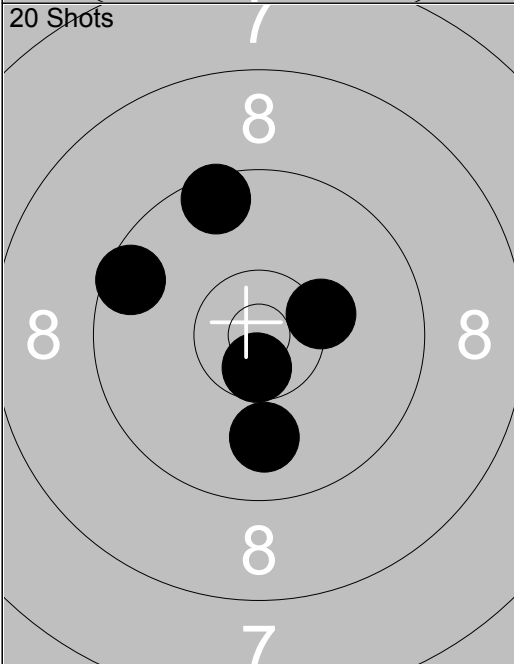
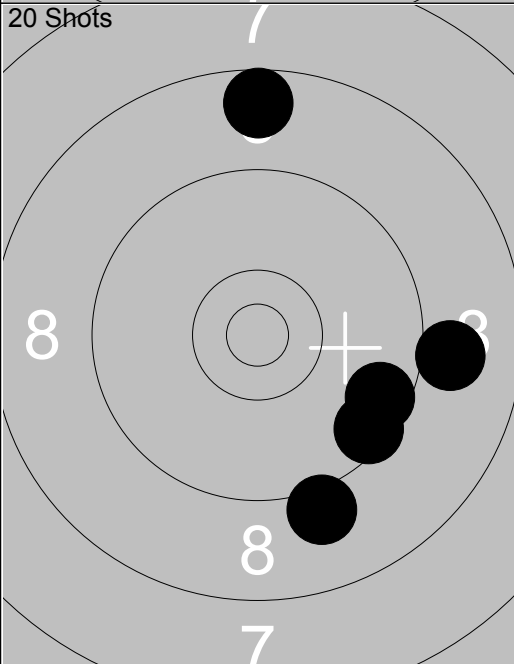
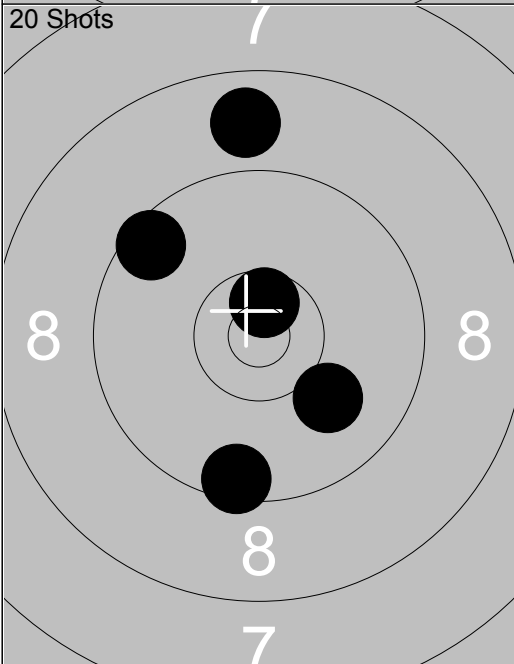
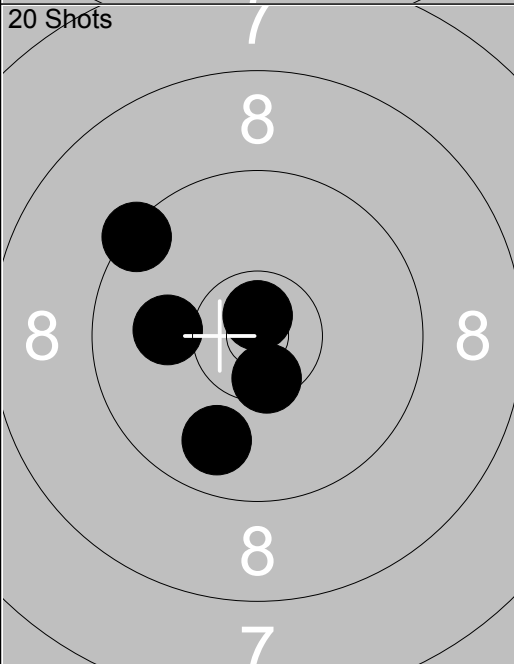

Relay	Lane	Håkan Lidman			
2	1	50m	Skellefteå	Vet-L	Vb
08.07.2014		Tavelträffen Korthåll 2014		Ramselefors SKF	
Sight					
		1: 8.9 ↗ 2: *10.5 ↗ 3: 10.1 ↗ 4: 9.9 → 5: *10.8 ↓ 6: 8.2 ↑ 7: 9.8 ↗ 8: 9.1 ↗ 9: 8.4 ↖ 10: 9.6 ↖		11: 9.2 → 12: 9.6 →	
		Series 90.0		Series 18.0	
		Total 0.0		Total 0.0	
20 Shots					
		1: *10.6 ↓ 2: 9.6 ↖ 3: 9.9 ↓ 4: *10.3 → 5: 9.5 ↑		6: 8.6 ↑ 7: 9.1 ↓ 8: 9.6 → 9: 9.5 ↓ 10: 9.0 →	
		Series 47.0		Series 44.0	
		Total 47.0		Total 91.0	
20 Shots					
		11: 10.0 ↘ 12: 9.5 ↓ 13: *10.6 ↑ 14: 8.8 ↑ 15: 9.5 ↖		16: 9.4 ↖ 17: 9.8 ↓ 18: *10.5 ↓ 19: *10.7 ↑ 20: 10.1 ↖	
		Series 46.0		Series 48.0	
		Total 137.0		Total 185.0	

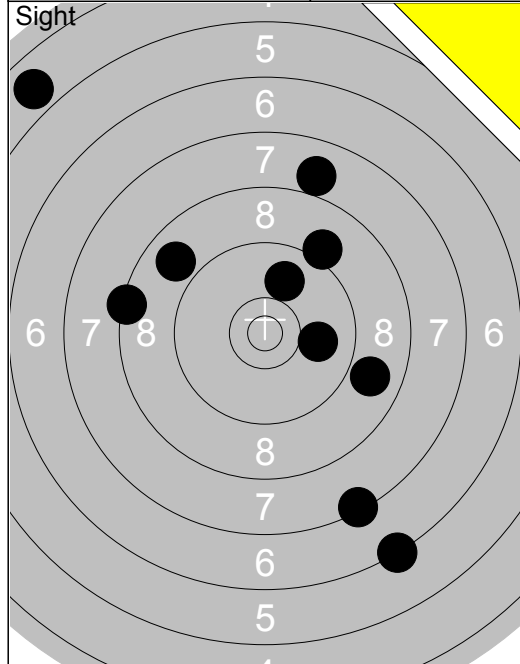

1:	4.9	↗
2:	7.4	↘
3:	6.3	↘
4:	8.9	→
5:	10.0	→
6:	8.0	↑
7:	9.1	↗
8:	9.9	↑
9:	8.4	←
10:	8.9	↖
<b>Series</b>		<b>77.0</b>
<b>Total</b>		<b>0.0</b>

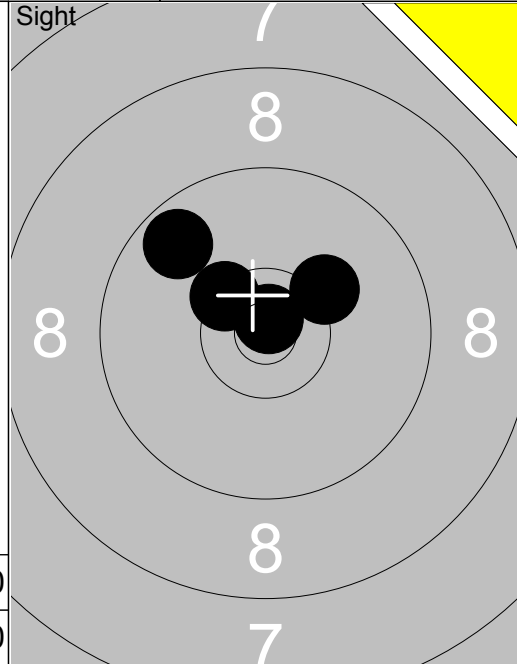

11:	10.2	↗
12:	9.7	↖
13:	*10.4	↖
14:	*10.8	↑
<b>Series</b>		<b>39.0</b>
<b>Total</b>		<b>0.0</b>

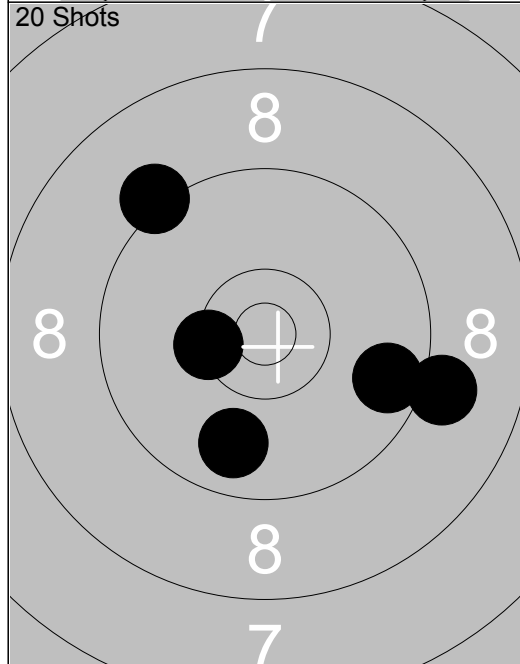

1:	*10.4	←
2:	9.2	↗
3:	9.7	→
4:	9.1	→
5:	9.8	↘
<b>Series</b>		<b>46.0</b>
<b>Total</b>		<b>46.0</b>

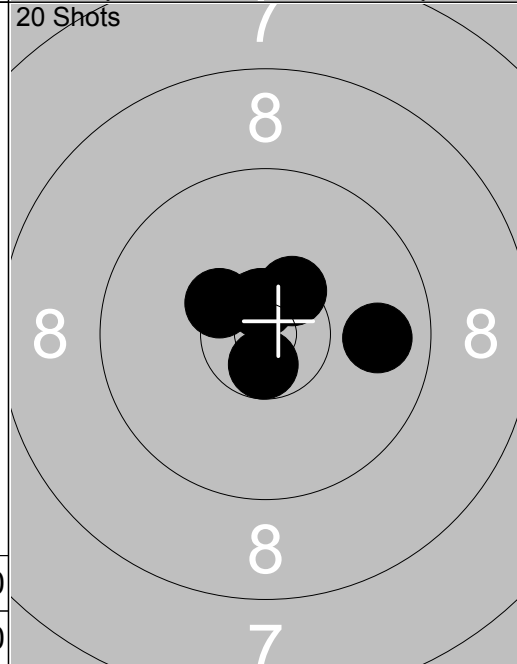

6:	*10.4	↗
7:	9.8	→
8:	*10.4	↖
9:	*10.6	↑
10:	*10.6	↘
<b>Series</b>		<b>49.0</b>
<b>Total</b>		<b>95.0</b>

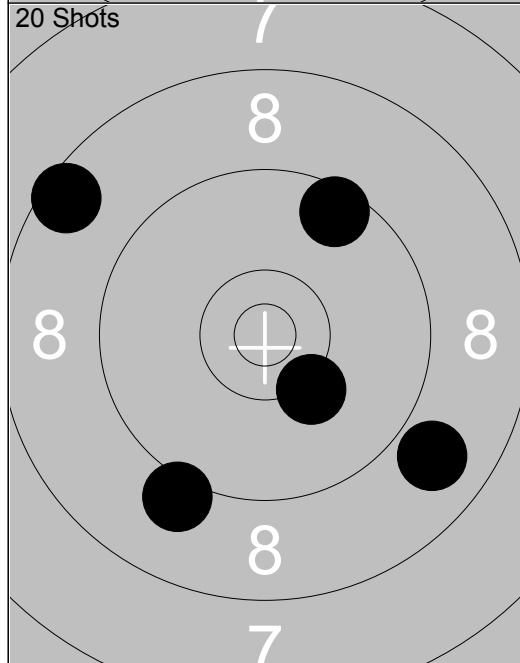

11:	8.5	↖
12:	9.5	↗
13:	10.2	↘
14:	8.9	↘
15:	9.1	↘
<b>Series</b>		<b>44.0</b>
<b>Total</b>		<b>139.0</b>

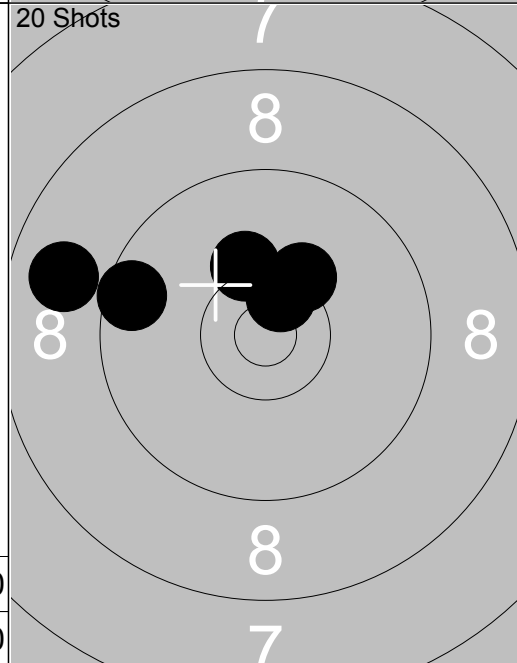

16:	10.2	↑
17:	10.3	↗
18:	8.9	←
19:	9.6	←
20:	*10.5	↑
<b>Series</b>		<b>47.0</b>
<b>Total</b>		<b>186.0</b>

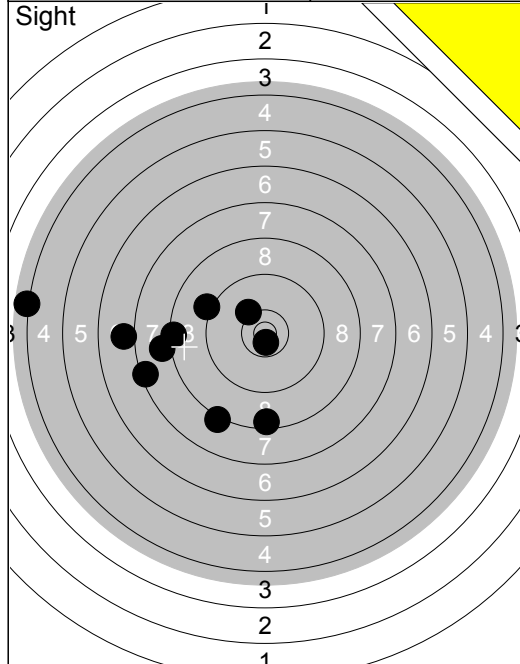

1:	4.3	←
2:	7.4	←
3:	8.2	↘
4:	8.5	↓
5:	8.1	←
6:	8.4	←
7:	7.0	←
8:	9.2	↖
9:	*10.7	↓
10:	10.2	↖
Series		79.0
Total		0.0

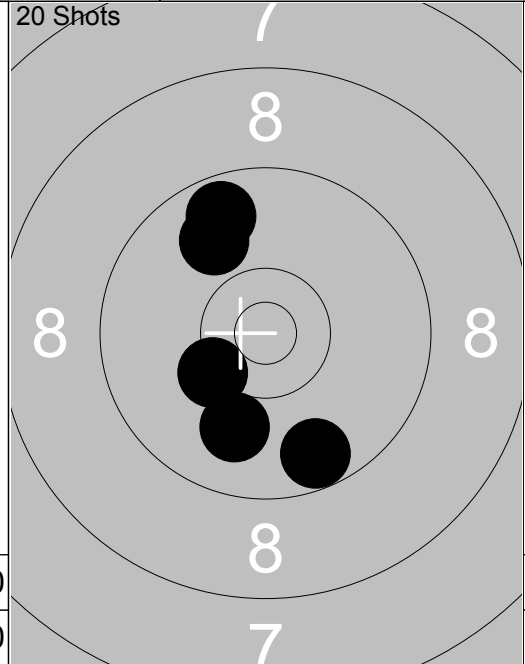

1:	9.7	↘
2:	10.0	↘
3:	*10.3	↘
4:	9.7	↗
5:	9.9	↗
Series		47.0
Total		47.0

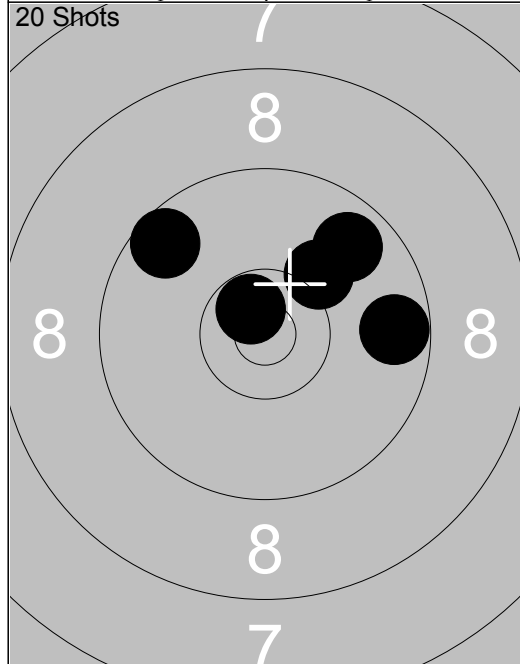

6:	*10.7	↖
7:	9.6	↖
8:	10.1	↗
9:	9.7	→
10:	9.8	↗
Series		47.0
Total		94.0

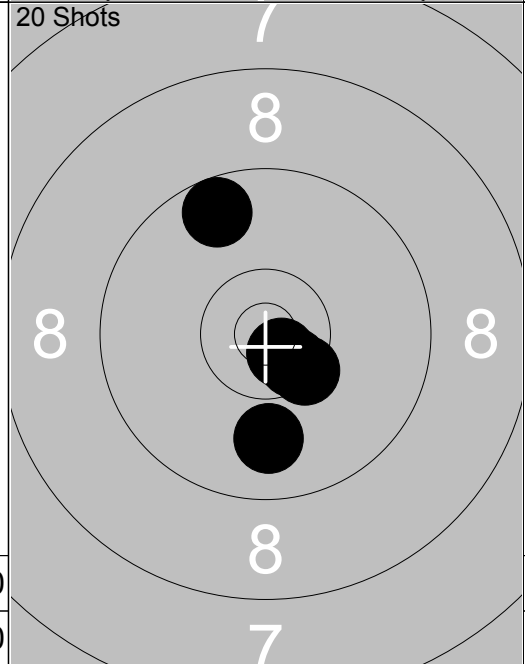

11:	9.9	↓
12:	*10.7	↘
13:	*10.5	↘
14:	*10.4	↘
15:	9.6	↗
Series		48.0
Total		142.0

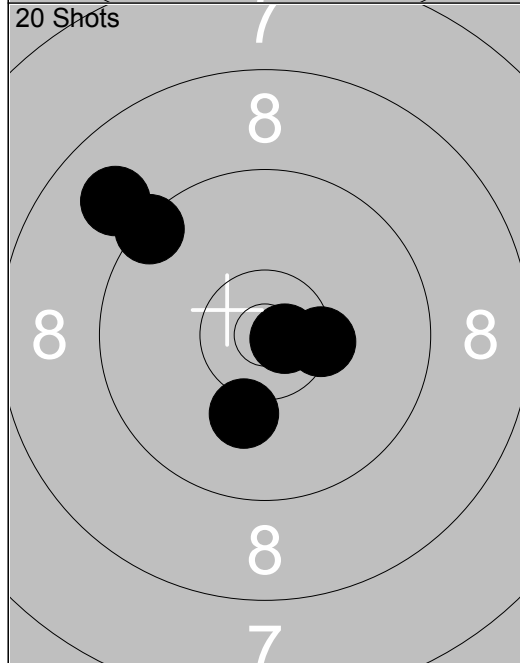

16:	9.4	↖
17:	*10.8	→
18:	8.9	↖
19:	*10.4	→
20:	10.1	↓
Series		47.0
Total		189.0

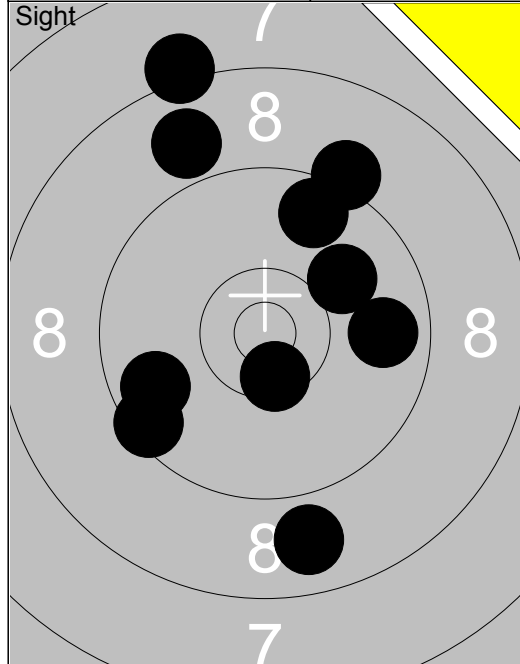

1:	8.2	↑
2:	9.8	→
3:	8.9	↑
4:	10.0	↗
5:	9.2	↑
6:	9.7	←
7:	*10.5	↓
8:	9.5	←
9:	8.8	↓
10:	9.7	↑
Series		89.0
Total		0.0

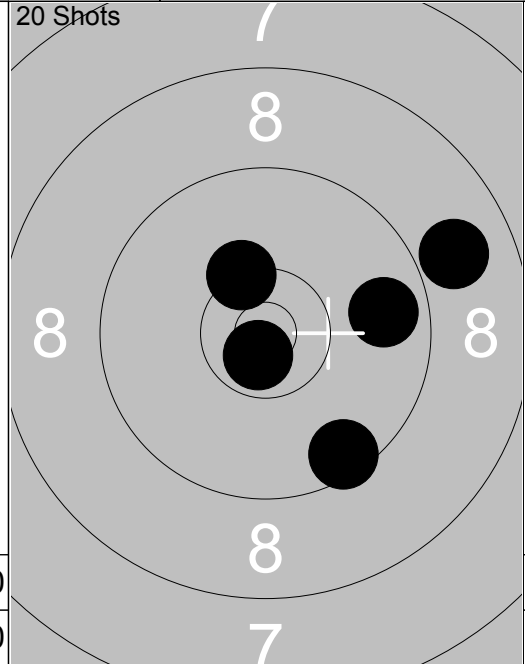

1:	*10.7	↓
2:	*10.3	↖
3:	9.5	↓
4:	9.8	→
5:	8.9	→
Series		46.0
Total		46.0

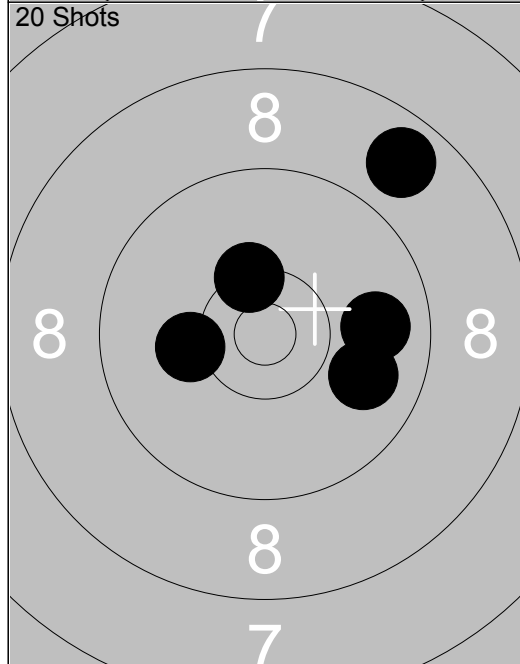

6:	10.2	←
7:	9.8	→
8:	9.9	→
9:	*10.4	↖
10:	8.8	↗
Series		46.0
Total		92.0

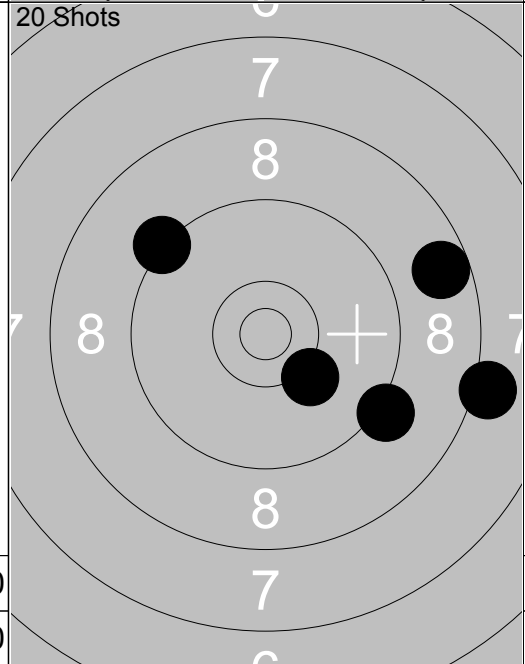

11:	8.1	→
12:	9.2	↘
13:	9.3	↖
14:	10.2	↘
15:	8.7	→
Series		44.0
Total		136.0

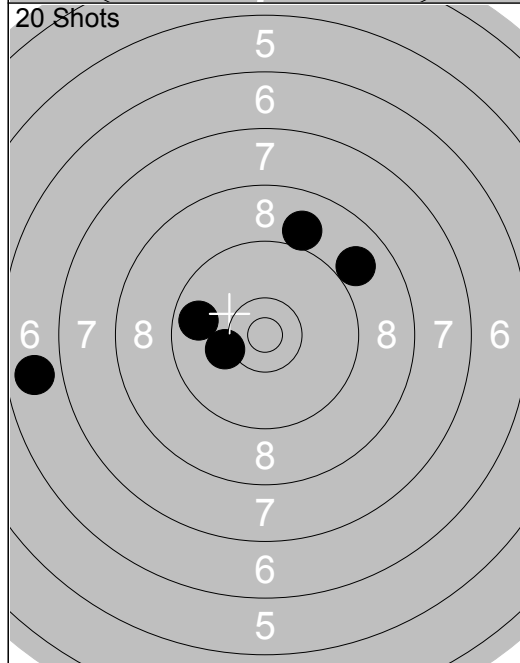

16:	8.9	↗
17:	10.2	←
18:	6.8	←
19:	9.7	←
20:	9.0	↑
Series		42.0
Total		178.0

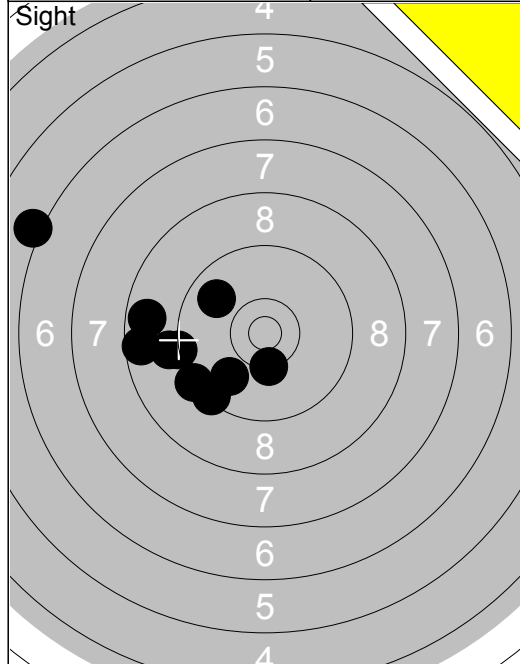

1:	6.1	↙
2:	*10.3	↓
3:	9.8	↖
4:	8.7	←
5:	9.3	↙
6:	9.4	↙
7:	9.9	↙
8:	9.3	←
9:	9.1	←
10:	8.6	←
<b>Series</b>		<b>86.0</b>
<b>Total</b>		<b>0.0</b>

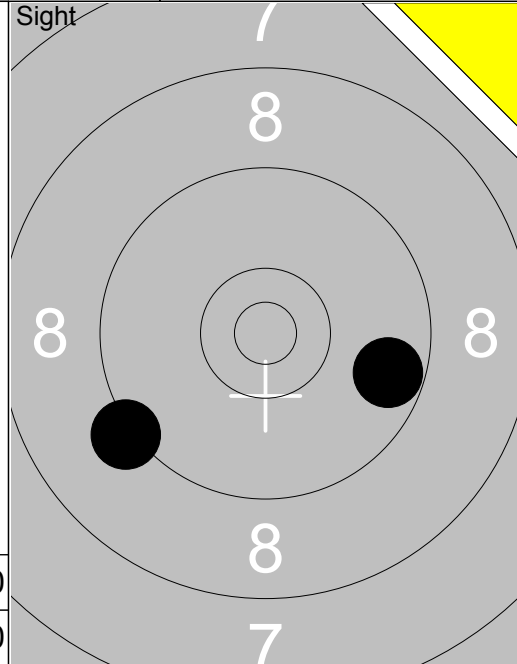

11:	9.2	↙
12:	9.7	→
<b>Series</b>		<b>18.0</b>
<b>Total</b>		<b>0.0</b>

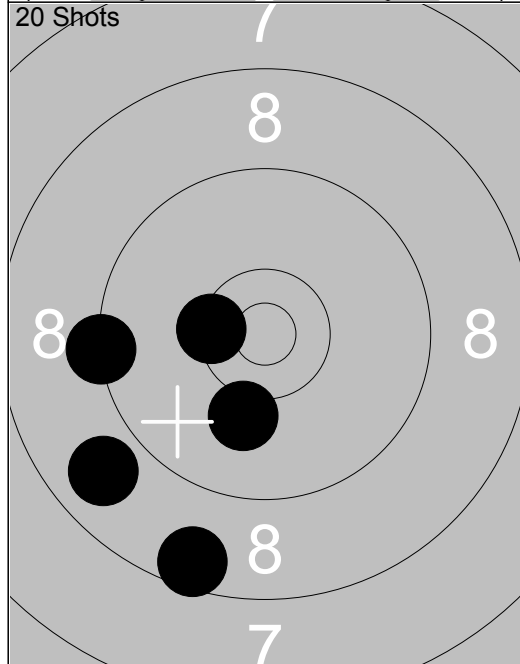

1:	8.8	↙
2:	9.3	←
3:	8.6	↓
4:	*10.4	←
5:	10.1	↓
<b>Series</b>		<b>45.0</b>
<b>Total</b>		<b>45.0</b>

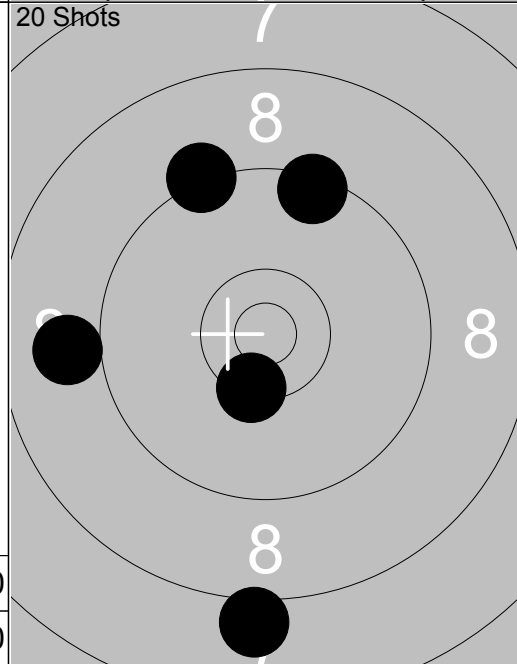

6:	9.0	←
7:	*10.4	↓
8:	9.3	↖
9:	9.4	↗
10:	8.1	↓
<b>Series</b>		<b>45.0</b>
<b>Total</b>		<b>90.0</b>

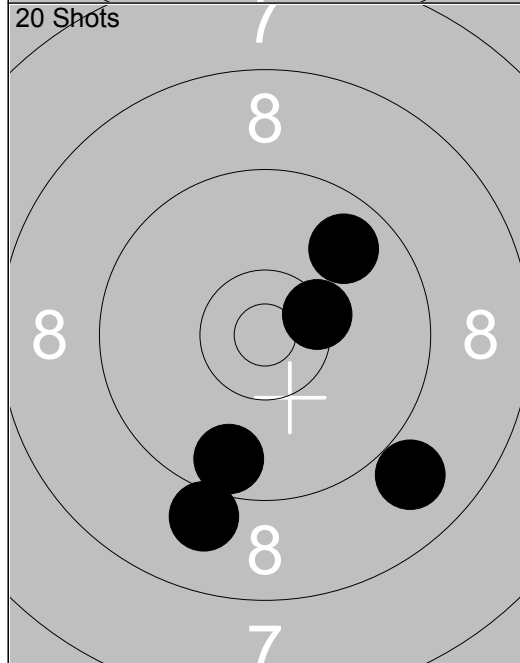

11:	9.7	↓
12:	8.9	↘
13:	9.8	↗
14:	*10.4	→
15:	9.0	↓
<b>Series</b>		<b>45.0</b>
<b>Total</b>		<b>135.0</b>

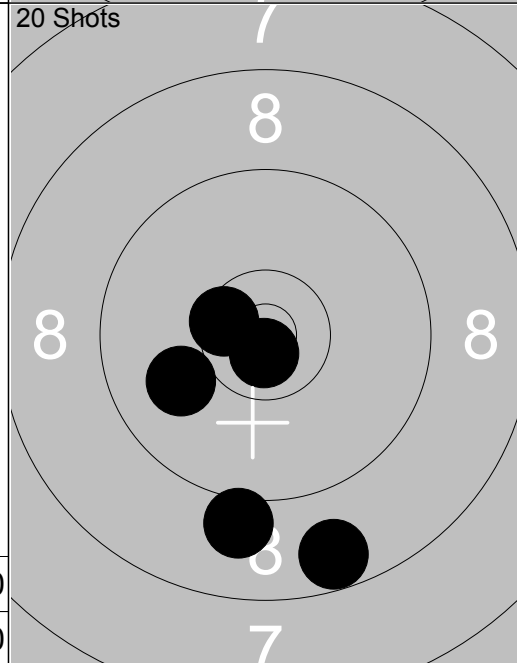

16:	9.1	↓
17:	10.0	↙
18:	*10.8	↓
19:	8.7	↓
20:	*10.5	↙
<b>Series</b>		<b>47.0</b>
<b>Total</b>		<b>182.0</b>

<p>Sight</p>	<p>Sight</p>
--------------	--------------

<p>20 Shots</p>	<p>20 Shots</p>
-----------------	-----------------

<p>20 Shots</p>	<p>20 Shots</p>
-----------------	-----------------

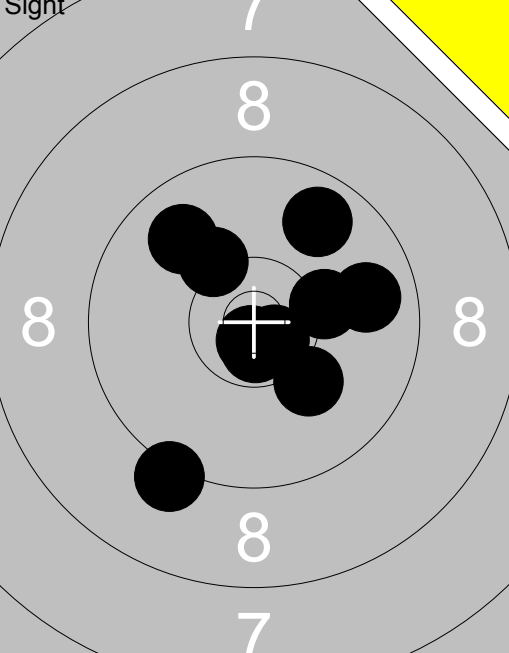
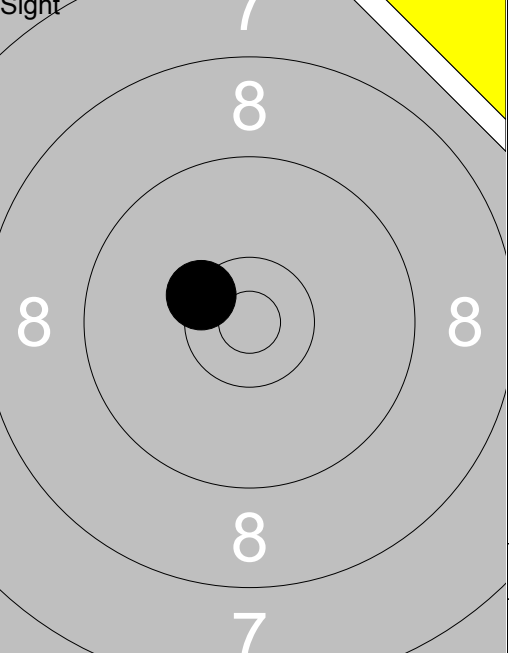
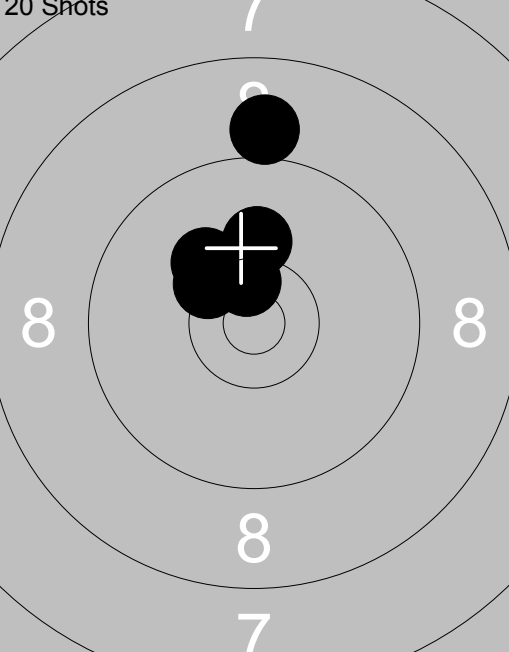
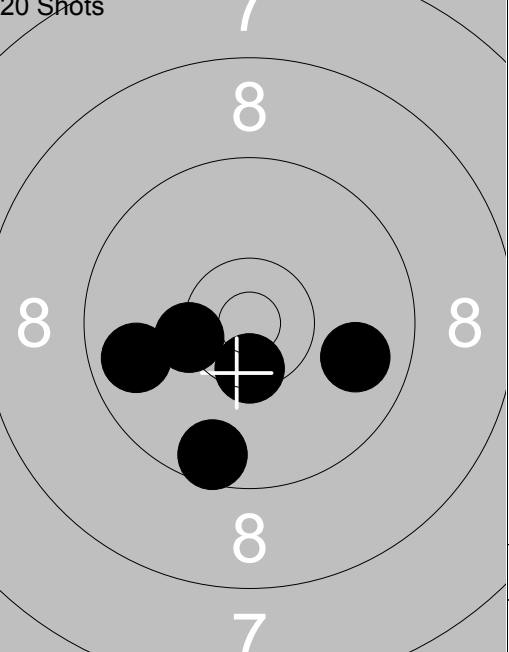
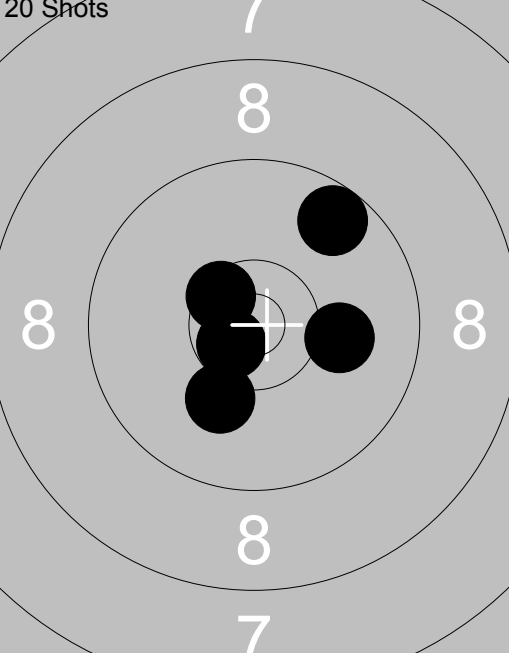
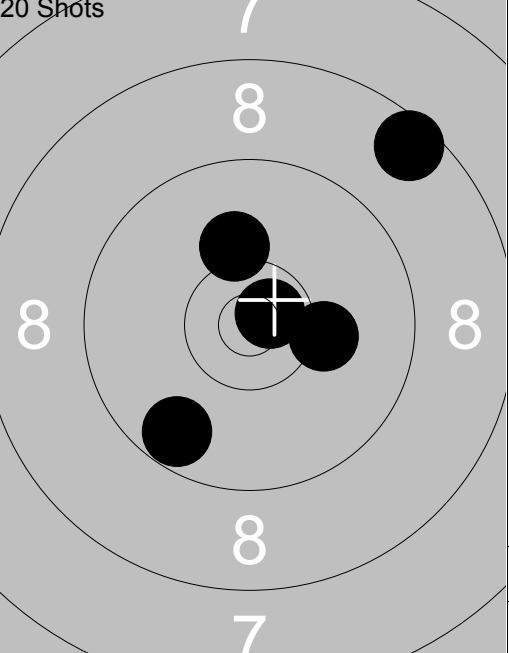
<p>Sight</p> 	<p>1: 10.2 ↘ 2: 9.2 ↓ 3: *10.7 ↘ 4: *10.7 ↓ 5: 9.8 ↗ 6: 10.2 ↖ 7: 9.8 → 8: 9.9 ↖ 9: *10.8 ↓ 10: 10.2 →</p> <p>Series 96.0 Total 0.0</p>	<p>Sight</p>  <p>11: *10.4 ↖</p> <p>Series 10.0 Total 0.0</p>
<p>20 Shots</p> 	<p>1: 10.2 ↖ 2: *10.3 ↖ 3: 9.0 ↑ 4: *10.5 ↖ 5: 10.1 ↑</p> <p>Series 49.0 Total 49.0</p>	<p>20 Shots</p>  <p>6: *10.3 ↖ 7: *10.5 ↓ 8: 9.8 ← 9: 9.6 ↓ 10: 9.8 →</p> <p>Series 47.0 Total 96.0</p>
<p>20 Shots</p> 	<p>11: 10.1 → 12: *10.7 ↖ 13: *10.5 ↖ 14: 10.1 ↓ 15: 9.6 ↗</p> <p>Series 49.0 Total 145.0</p>	<p>20 Shots</p>  <p>16: 10.2 ↑ 17: 9.7 ↓ 18: *10.7 ↗ 19: 10.2 → 20: 8.6 ↗</p> <p>Series 47.0 Total 192.0</p>

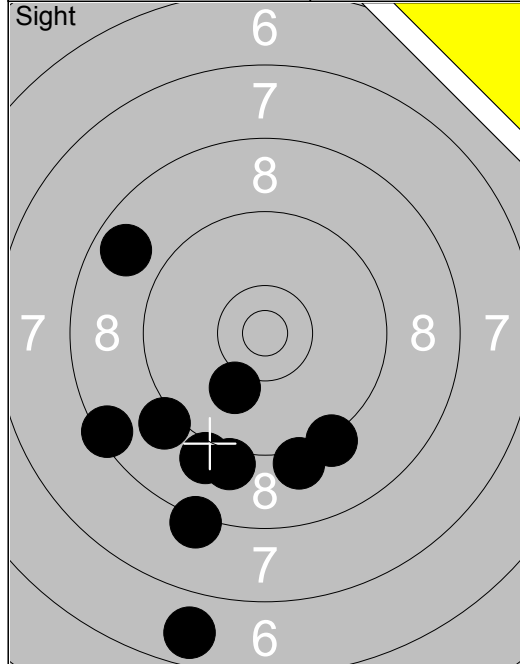

1: 8.4 ↙
2: 9.2 ↓
3: 6.8 ↓
4: 8.2 ↓
5: 9.1 ↓
6: 9.1 ↙
7: 8.7 ↖
8: 9.1 ↓
9: 9.1 ↓
10: 10.1 ↓
<b>Series 85.0</b>
<b>Total 0.0</b>

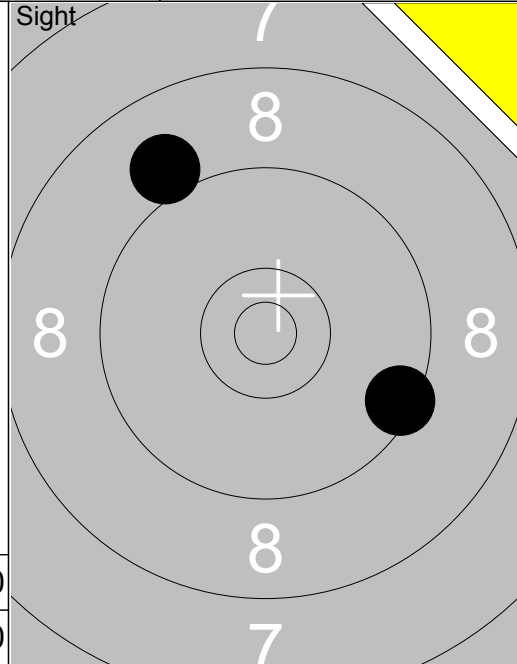

11: 9.4 →
12: 9.0 ↗
<b>Series 18.0</b>
<b>Total 0.0</b>

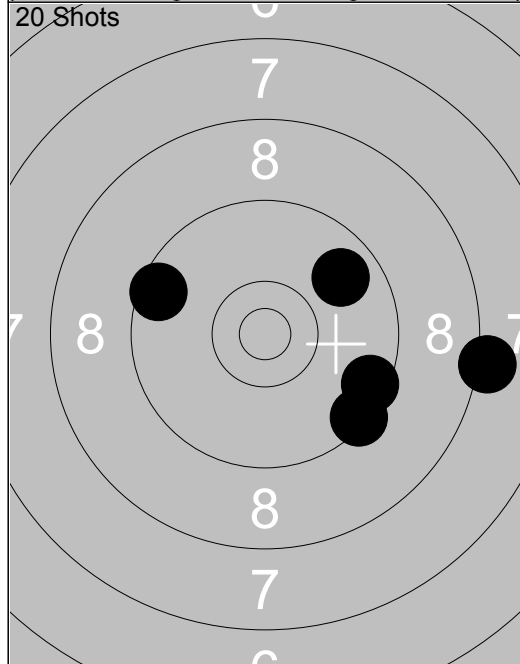

1: 9.5 ↖
2: 9.4 ↓
3: 8.2 →
4: 9.8 ↗
5: 9.5 →
<b>Series 44.0</b>
<b>Total 44.0</b>

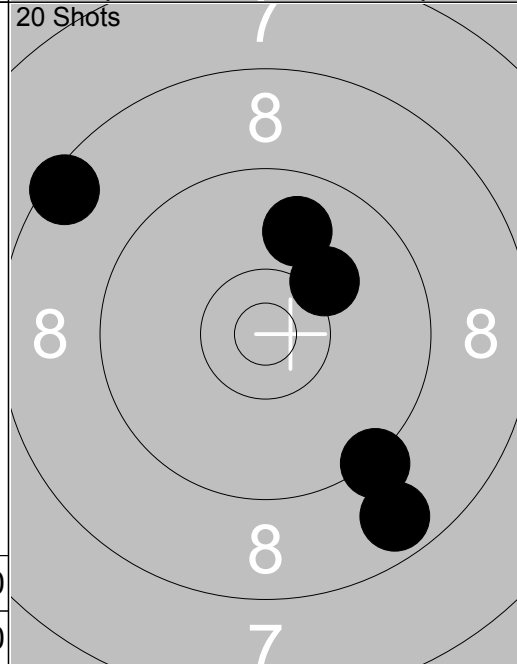

6: 8.5 ↖
7: 8.7 ↓
8: 9.3 ↓
9: 9.9 ↑
10: 10.2 ↗
<b>Series 44.0</b>
<b>Total 88.0</b>

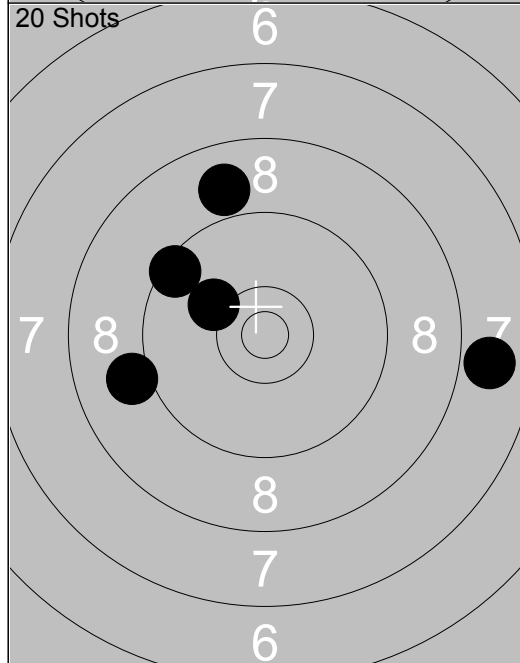

11: 9.5 ↖
12: 8.9 ↑
13: 7.9 →
14: 10.2 ↖
15: 9.1 ↖
<b>Series 43.0</b>
<b>Total 131.0</b>

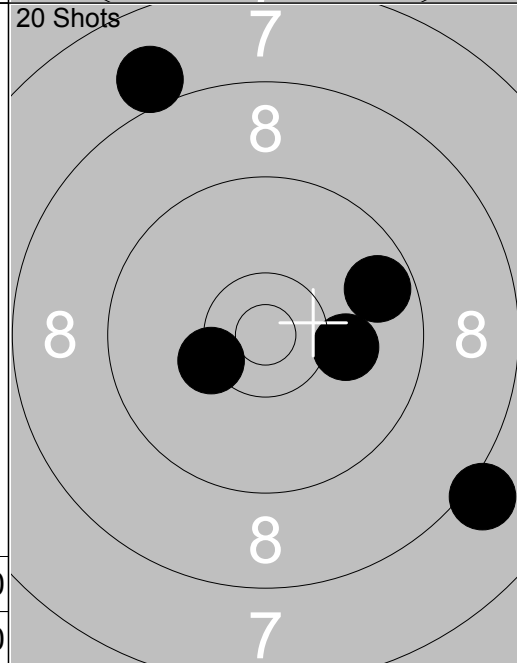

16: 8.1 ↓
17: 9.7 ↗
18: 10.1 →
19: *10.3 ↖
20: 8.0 ↖
<b>Series 45.0</b>
<b>Total 176.0</b>

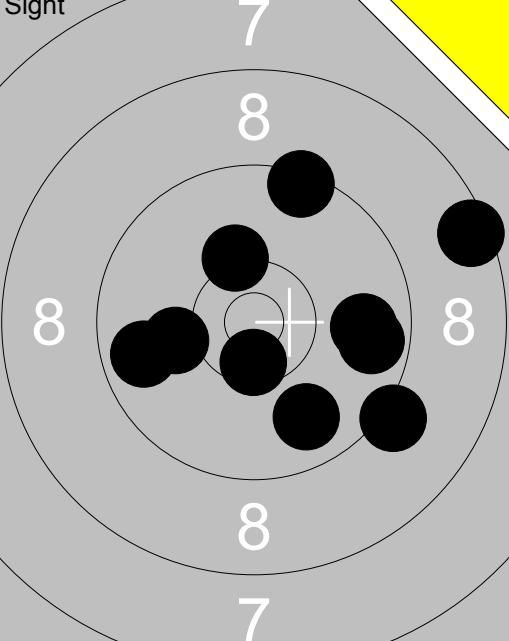
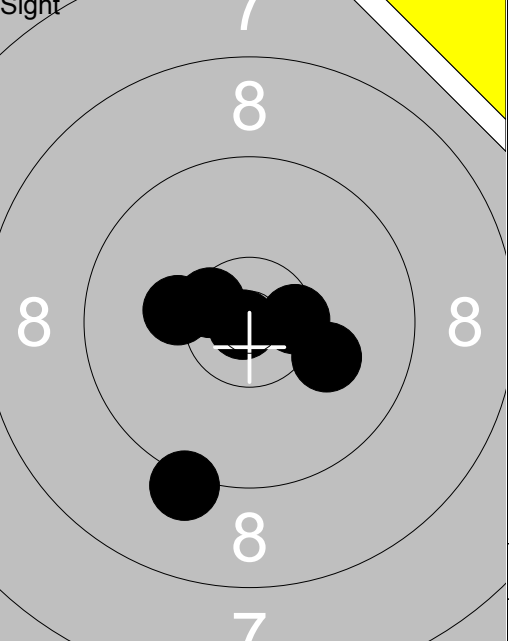

<p>Sight</p> 	<p>1: 9.4 ↗ 2: 8.5 → 3: 9.8 → 4: *10.5 ↓ 5: 9.8 ↓ 6: 9.2 ↓ 7: 9.7 → 8: 10.2 ↑ 9: 9.7 ← 10: 10.1 ←</p> <p>Series 92.0 Total 0.0</p>	<p>Sight</p>  <p>11: 9.2 ↓ 12: *10.5 ↘ 13: *10.9 ↘ 14: 10.2 ← 15: 10.1 → 16: *10.5 →</p> <p>Series 59.0 Total 0.0</p>
---	--	---

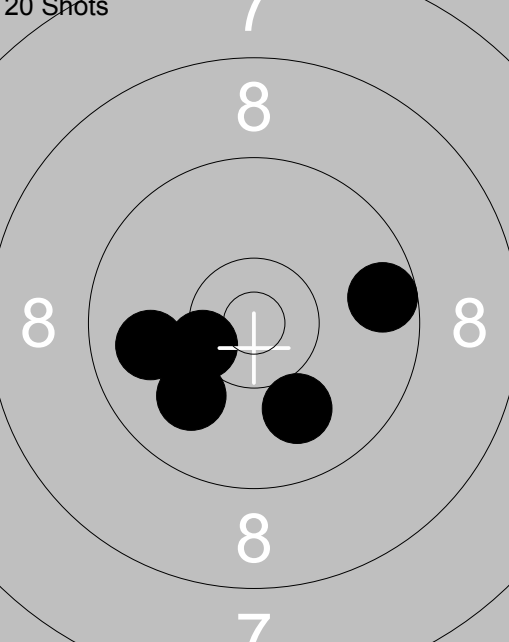
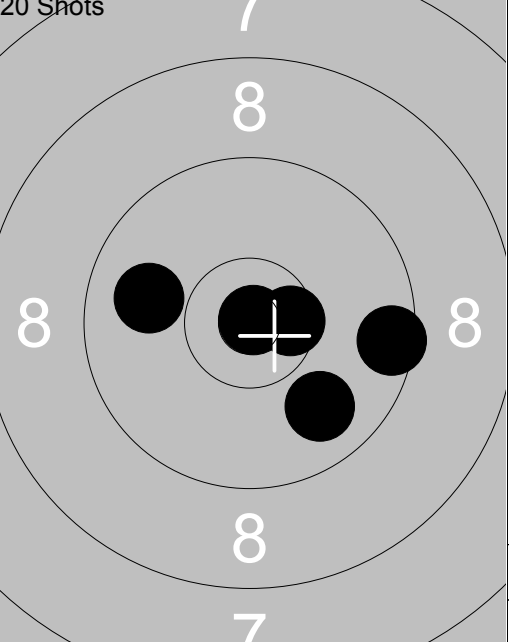
<p>20 Shots</p>  <p>1: 9.9 ← 2: *10.4 ↘ 3: 10.0 ↘ 4: 10.0 ↓ 5: 9.6 →</p> <p>Series 48.0 Total 48.0</p>	<p>20 Shots</p>  <p>6: 9.9 ← 7: 9.9 ↓ 8: *10.9 ↗ 9: *10.5 → 10: 9.5 →</p> <p>Series 47.0 Total 95.0</p>
---	--

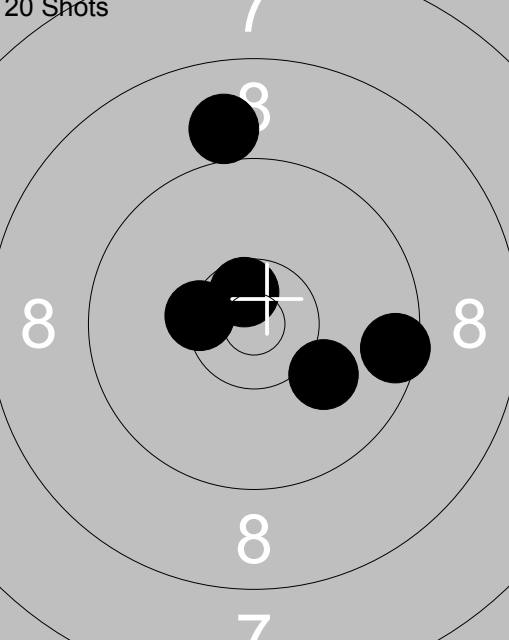
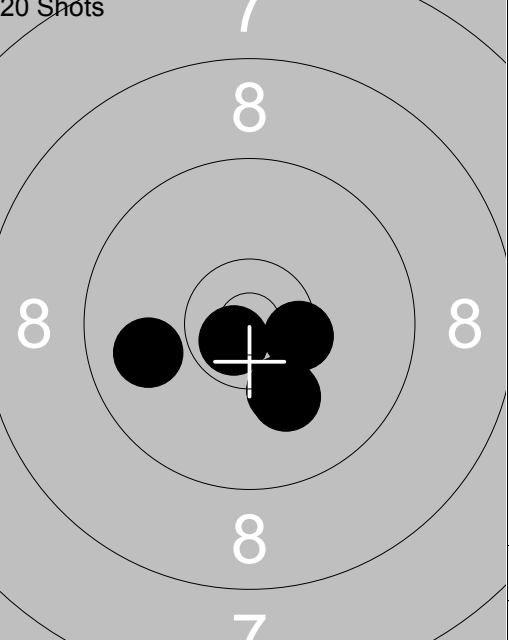
<p>20 Shots</p>  <p>11: 10.1 ↓ 12: 9.5 → 13: *10.6 ↗ 14: *10.4 ← 15: 9.0 ↑</p> <p>Series 48.0 Total 143.0</p>	<p>20 Shots</p>  <p>16: 9.9 ← 17: 10.1 ↓ 18: *10.4 → 19: 10.2 ↓ 20: *10.7 ↘</p> <p>Series 49.0 Total 192.0</p>
---	--

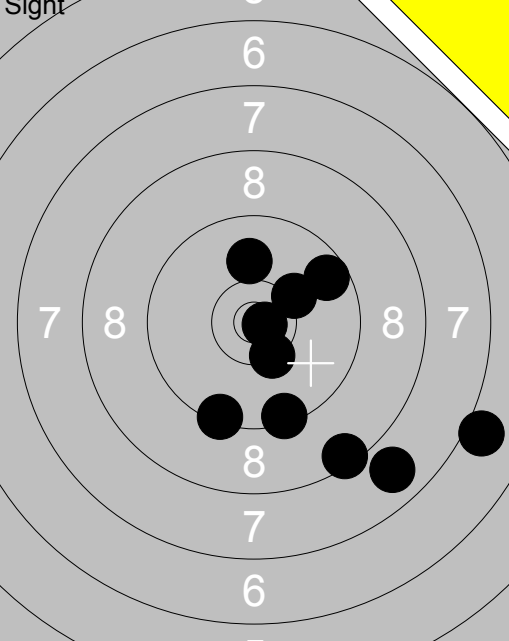
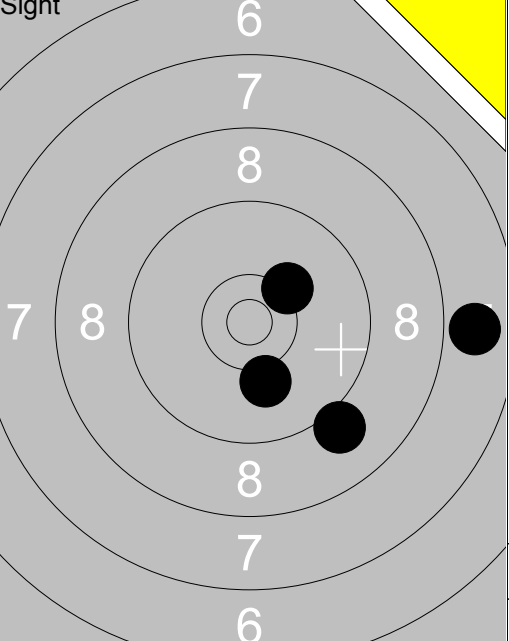
 <p>Sight</p>	<p>1: 9.4 ↓ 2: 7.8 ↓ 3: 10.0 ↑ 4: 9.6 ↗ 5: 8.5 ↓ 6: 9.4 ↓ 7: 7.0 → 8: 10.2 ↗ 9: *10.4 ↓ 10: *10.8 →</p> <p>Series 89.0 Total 0.0</p>	 <p>Sight</p>	<p>11: 10.1 ↓ 12: 10.3 ↗ 13: 9.1 ↓ 14: 7.9 →</p> <p>Series 36.0 Total 0.0</p>
---	--	---	---

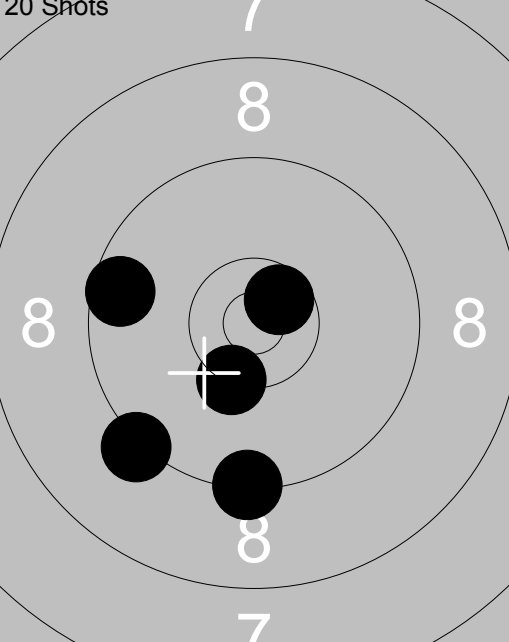
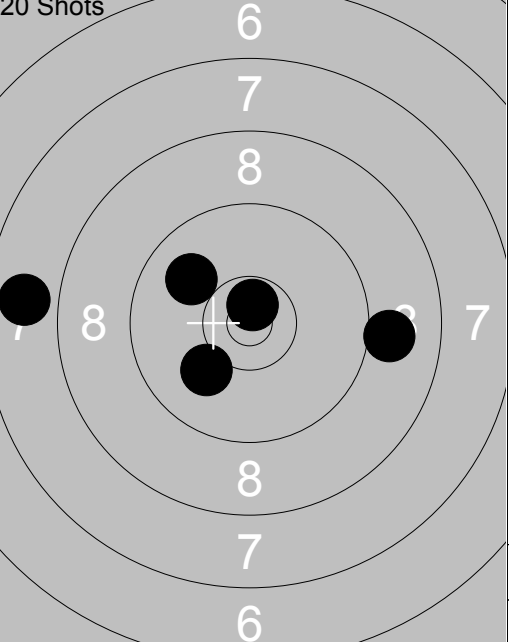
 <p>20 Shots</p>	<p>1: 9.2 ↓ 2: 9.6 ← 3: *10.3 ↓ 4: 9.3 ↓ 5: *10.6 ↗</p> <p>Series 47.0 Total 47.0</p>	 <p>20 Shots</p>	<p>6: 9.9 ↖ 7: 9.0 → 8: 7.8 ← 9: 10.1 ↙ 10: *10.7 ↑</p> <p>Series 45.0 Total 92.0</p>
---	---	---	---

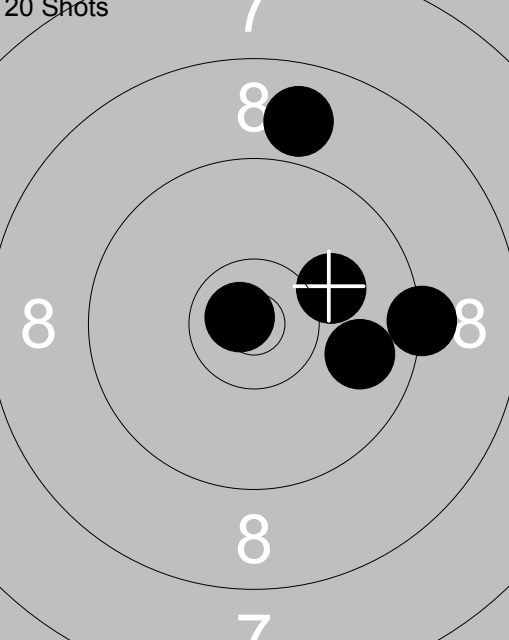
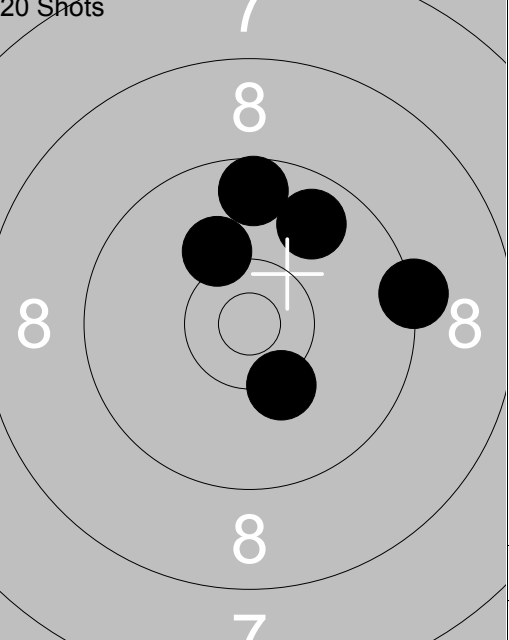
 <p>20 Shots</p>	<p>11: 10.1 → 12: 9.3 → 13: 9.9 → 14: *10.8 ↖ 15: 8.9 ↑</p> <p>Series 46.0 Total 138.0</p>	 <p>20 Shots</p>	<p>16: 10.3 ↓ 17: 9.6 ↑ 18: 10.2 ↖ 19: 9.8 ↗ 20: 9.3 →</p> <p>Series 47.0 Total 185.0</p>
--	--	--	---

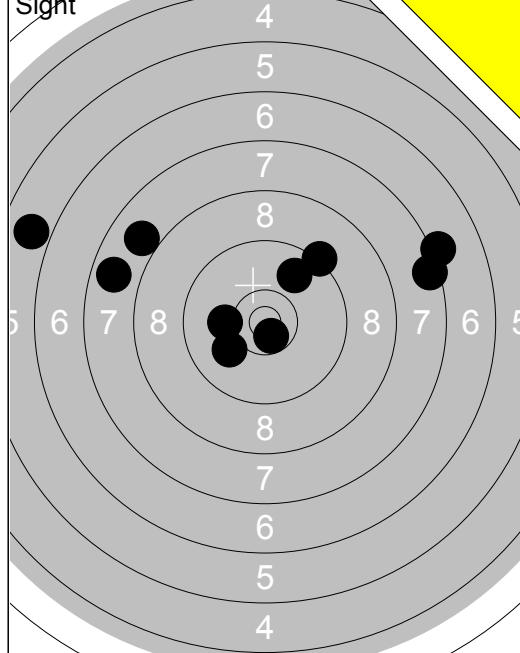

1:	9.3 ↗
2:	*10.6 ↘
3:	7.5 →
4:	7.2 →
5:	9.8 ↗
6:	7.9 ↖
7:	10.1 ←
8:	5.9 ↖
9:	10.1 ↙
10:	7.8 ←
<b>Series 81.0</b>	
<b>Total 0.0</b>	

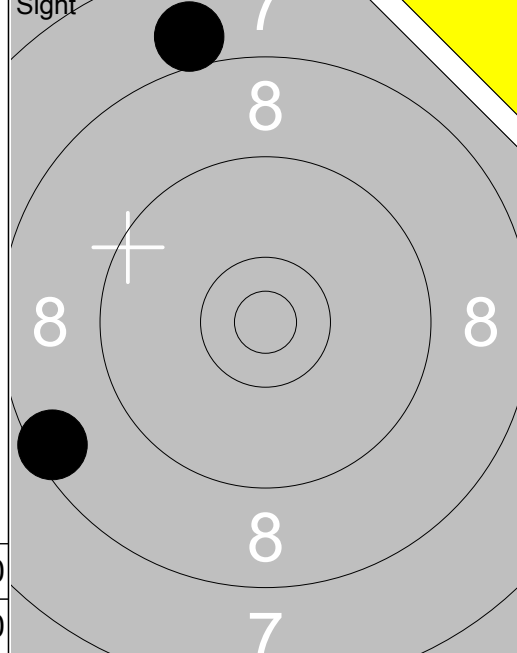

11:	8.0 ↗
12:	8.5 ↙
<b>Series 16.0</b>	
<b>Total 0.0</b>	

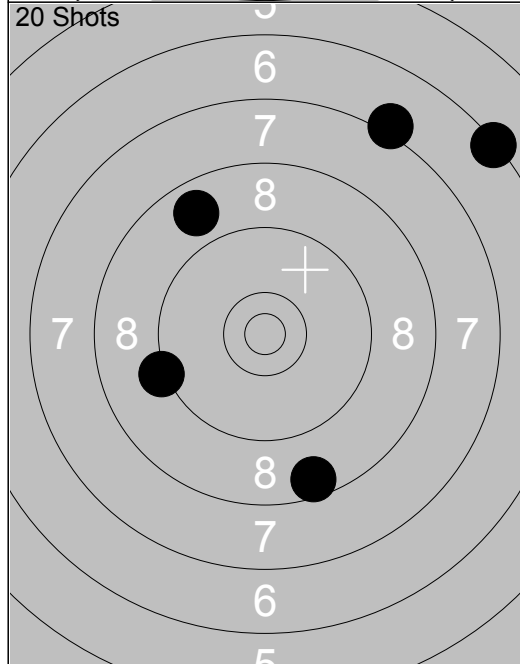

1:	8.8 ↖
2:	9.2 ←
3:	8.6 ↘
4:	7.2 ↗
5:	6.4 ↗
<b>Series 38.0</b>	
<b>Total 38.0</b>	

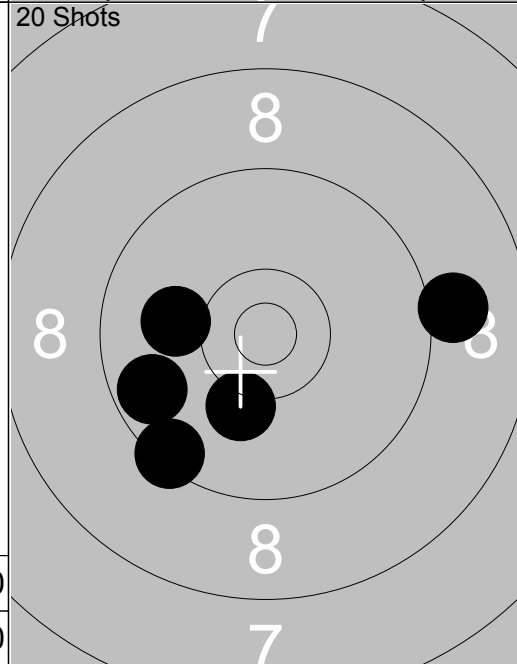

6:	9.4 ↙
7:	10.0 ←
8:	10.2 ↘
9:	9.7 ↖
10:	9.1 →
<b>Series 47.0</b>	
<b>Total 85.0</b>	

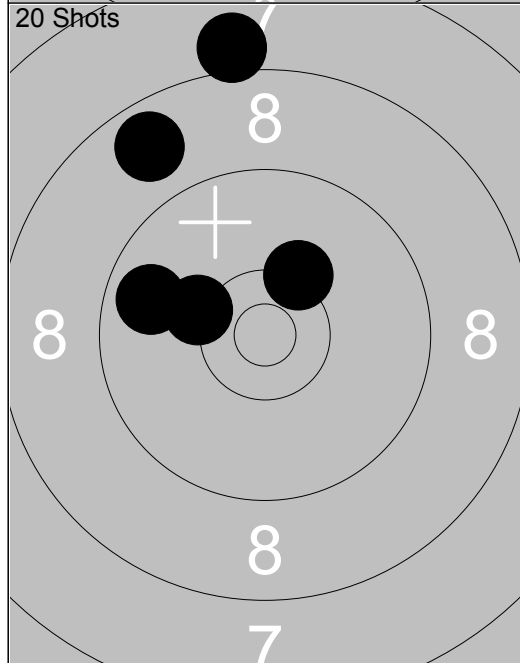

11:	8.1 ↗
12:	10.2 ↖
13:	9.8 ↖
14:	10.3 ↗
15:	8.7 ↖
<b>Series 45.0</b>	
<b>Total 130.0</b>	

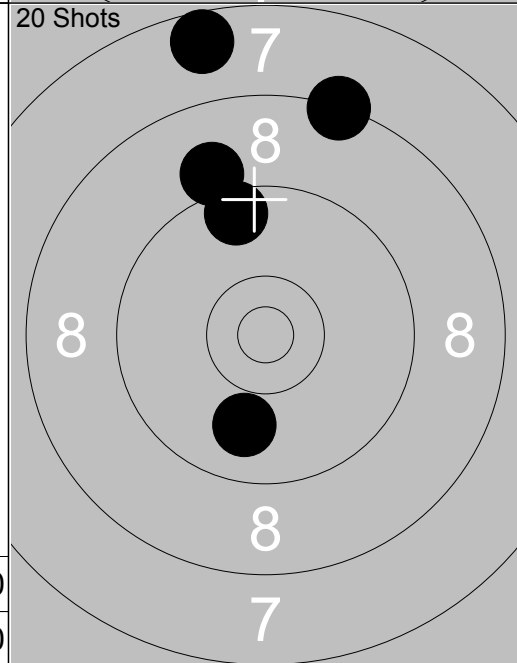

16:	9.1 ↖
17:	9.9 ↘
18:	9.6 ↗
19:	8.3 ↗
20:	7.6 ↗
<b>Series 42.0</b>	
<b>Total 172.0</b>	

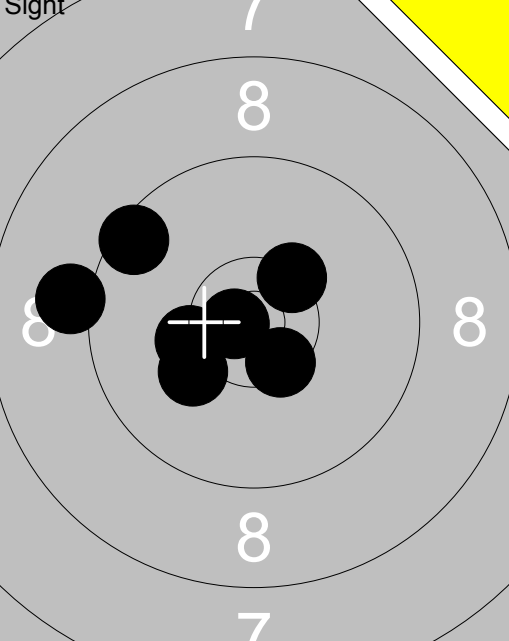
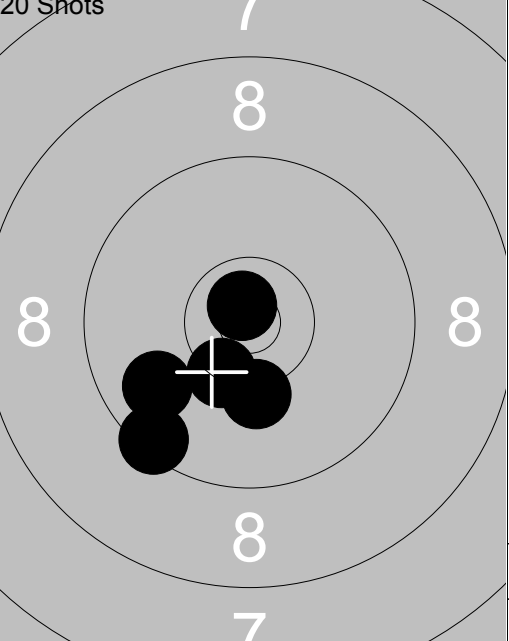
Sight		1: 9.5 ↙ 2: 9.1 ← 3: 10.3 ← 4: *10.4 ↗ 5: *10.5 ↓ 6: 10.2 ↙ 7: *10.8 ←	20 Shots		1: 9.4 ↙ 2: 10.2 ↓ 3: 9.8 ↙ 4: *10.8 ↗ 5: *10.4 ↓
	Series	68.0		Series	48.0
Total		0.0	Total		48.0

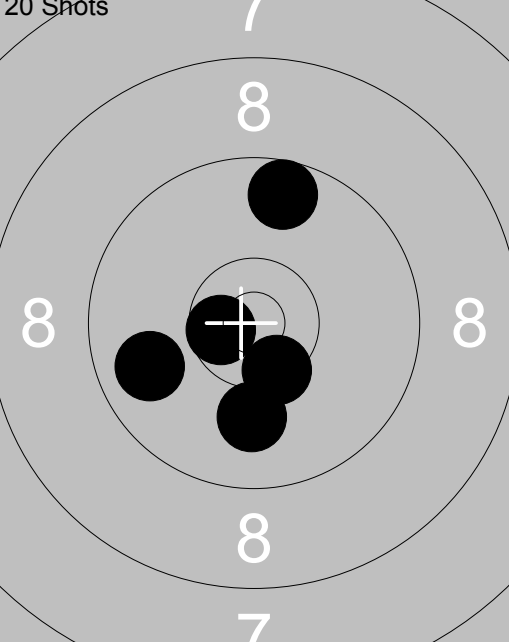
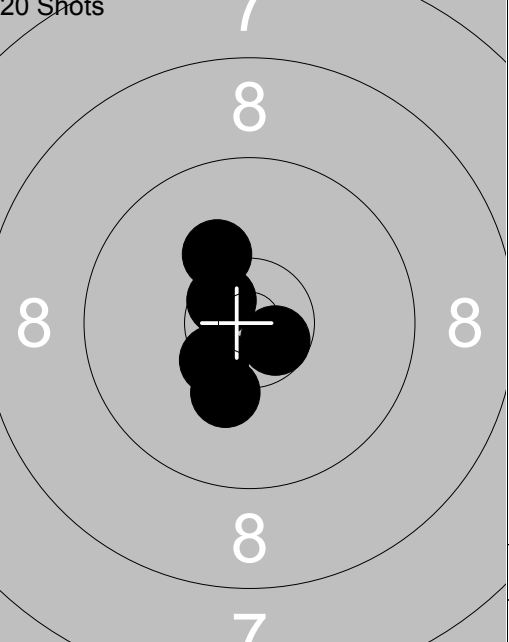
20 Shots		6: 9.8 ← 7: 9.6 ↑ 8: *10.4 ↓ 9: 10.0 ↓ 10: *10.6 ←	20 Shots		11: *10.6 ↗ 12: 10.2 ↗ 13: 10.2 ↓ 14: *10.6 ↗ 15: *10.4 ↓
	Series	48.0		Series	50.0
Total		96.0	Total		146.0

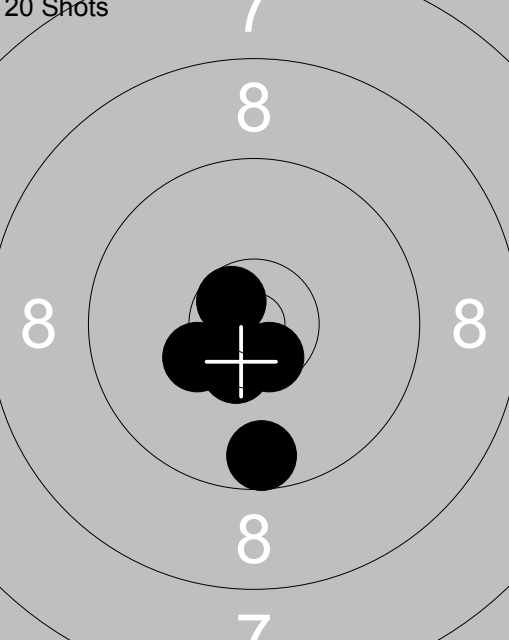
20 Shots		16: *10.6 ↗ 17: *10.6 ↓ 18: *10.3 ↗ 19: 9.6 ↓ 20: *10.5 ↓			
	Series	49.0			
Total		195.0			

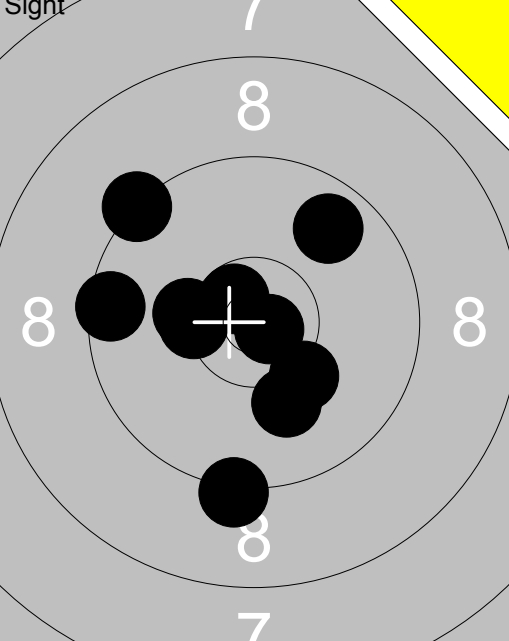
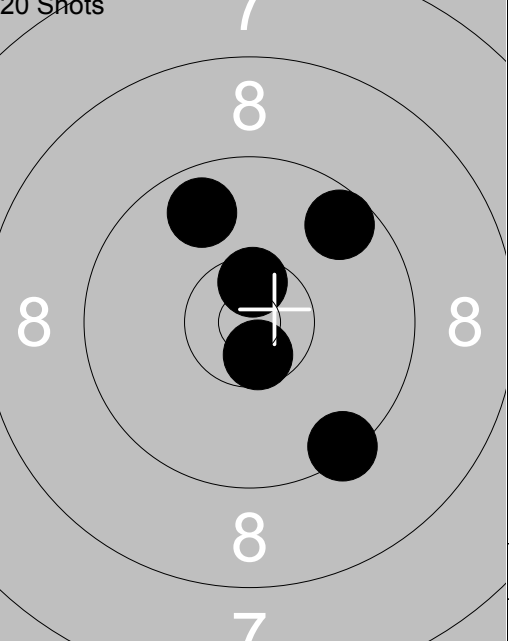
<p>Sight</p> 	<p>20 Shots</p> 	<table style="width:100%; border-collapse: collapse;"> <tr><td>1: 9.5 ←</td><td>1: 9.8 ↗</td></tr> <tr><td>2: 10.2 ↘</td><td>2: *10.6 ↘</td></tr> <tr><td>3: 10.1 ↘</td><td>3: *10.5 ↗</td></tr> <tr><td>4: *10.3 ←</td><td>4: 9.4 ↘</td></tr> <tr><td>5: 9.8 ↗</td><td>5: 9.6 ↗</td></tr> <tr><td>6: 10.3 ←</td><td></td></tr> <tr><td>7: *10.8 ↘</td><td></td></tr> <tr><td>8: 9.3 ↗</td><td></td></tr> <tr><td>9: 9.2 ↘</td><td></td></tr> <tr><td>10: *10.6 ↘</td><td></td></tr> <tr><td colspan="2"><b>Series 96.0</b></td></tr> <tr><td colspan="2"><b>Total 0.0</b></td></tr> </table>	1: 9.5 ←	1: 9.8 ↗	2: 10.2 ↘	2: *10.6 ↘	3: 10.1 ↘	3: *10.5 ↗	4: *10.3 ←	4: 9.4 ↘	5: 9.8 ↗	5: 9.6 ↗	6: 10.3 ←		7: *10.8 ↘		8: 9.3 ↗		9: 9.2 ↘		10: *10.6 ↘		<b>Series 96.0</b>		<b>Total 0.0</b>	
1: 9.5 ←	1: 9.8 ↗																									
2: 10.2 ↘	2: *10.6 ↘																									
3: 10.1 ↘	3: *10.5 ↗																									
4: *10.3 ←	4: 9.4 ↘																									
5: 9.8 ↗	5: 9.6 ↗																									
6: 10.3 ←																										
7: *10.8 ↘																										
8: 9.3 ↗																										
9: 9.2 ↘																										
10: *10.6 ↘																										
<b>Series 96.0</b>																										
<b>Total 0.0</b>																										

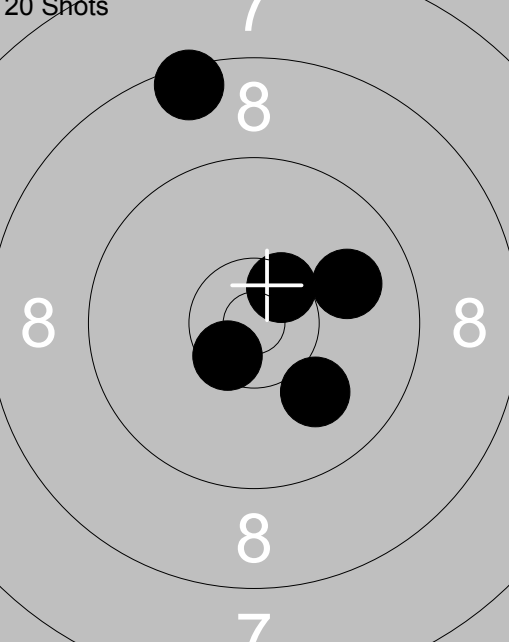
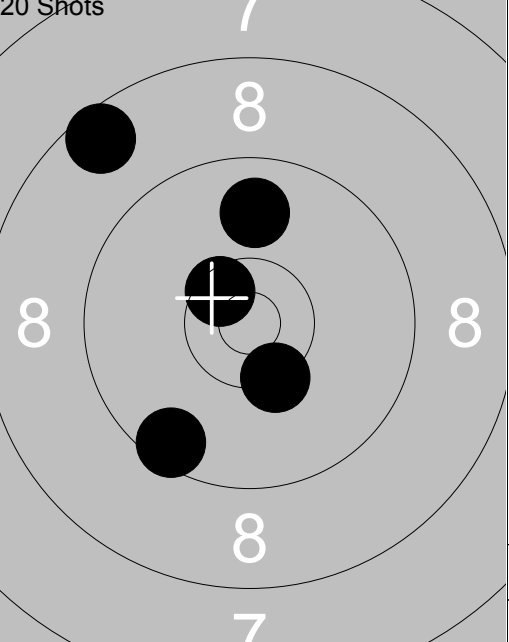
<p>20 Shots</p> 	<p>20 Shots</p> 	<table style="width:100%; border-collapse: collapse;"> <tr><td>6: *10.5 ↘</td><td>11: 8.6 ↘</td></tr> <tr><td>7: *10.5 ↗</td><td>12: *10.5 ↘</td></tr> <tr><td>8: 9.9 →</td><td>13: 9.8 ↑</td></tr> <tr><td>9: 10.0 ↘</td><td>14: 9.5 ↘</td></tr> <tr><td>10: 8.5 ↑</td><td>15: *10.4 ↘</td></tr> <tr><td colspan="2"><b>Series 47.0</b></td><td><b>Series 46.0</b></td></tr> <tr><td colspan="2"><b>Total 94.0</b></td><td><b>Total 140.0</b></td></tr> </table>	6: *10.5 ↘	11: 8.6 ↘	7: *10.5 ↗	12: *10.5 ↘	8: 9.9 →	13: 9.8 ↑	9: 10.0 ↘	14: 9.5 ↘	10: 8.5 ↑	15: *10.4 ↘	<b>Series 47.0</b>		<b>Series 46.0</b>	<b>Total 94.0</b>		<b>Total 140.0</b>
6: *10.5 ↘	11: 8.6 ↘																	
7: *10.5 ↗	12: *10.5 ↘																	
8: 9.9 →	13: 9.8 ↑																	
9: 10.0 ↘	14: 9.5 ↘																	
10: 8.5 ↑	15: *10.4 ↘																	
<b>Series 47.0</b>		<b>Series 46.0</b>																
<b>Total 94.0</b>		<b>Total 140.0</b>																

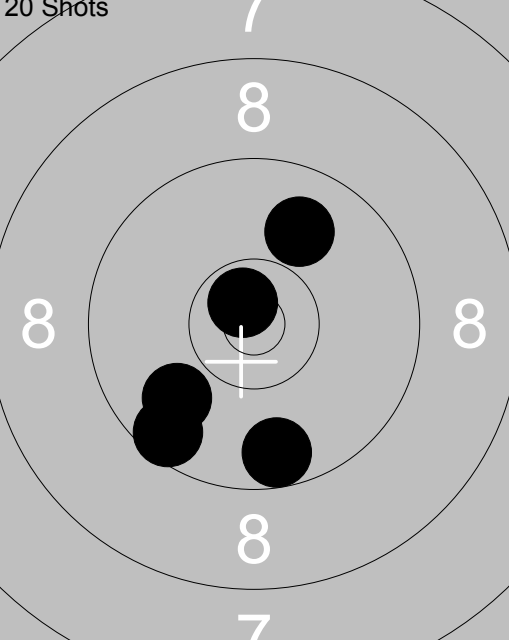
<p>20 Shots</p> 	<table style="width:100%; border-collapse: collapse;"> <tr><td>16: 9.9 ↘</td></tr> <tr><td>17: *10.7 ↗</td></tr> <tr><td>18: 9.6 ↘</td></tr> <tr><td>19: 9.6 ↘</td></tr> <tr><td>20: 9.9 ↗</td></tr> <tr><td colspan="2"><b>Series 46.0</b></td></tr> <tr><td colspan="2"><b>Total 186.0</b></td></tr> </table>	16: 9.9 ↘	17: *10.7 ↗	18: 9.6 ↘	19: 9.6 ↘	20: 9.9 ↗	<b>Series 46.0</b>		<b>Total 186.0</b>		
16: 9.9 ↘											
17: *10.7 ↗											
18: 9.6 ↘											
19: 9.6 ↘											
20: 9.9 ↗											
<b>Series 46.0</b>											
<b>Total 186.0</b>											

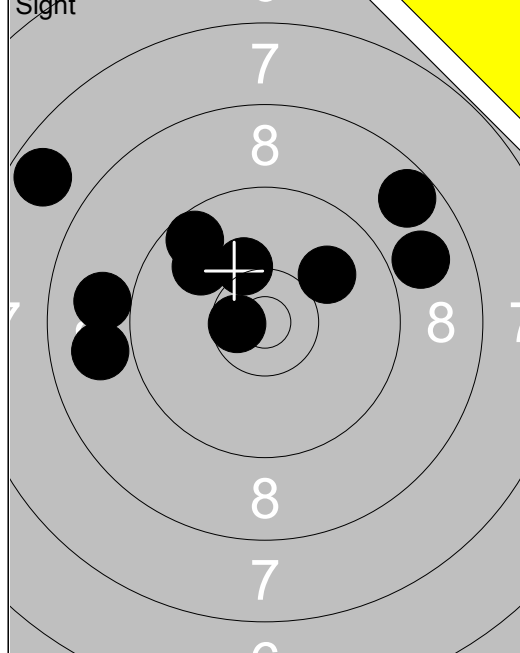

1: 9.0 ←
2: 7.7 ↖
3: 8.9 ←
4: 8.7 ↗
5: 10.0 ↗
6: 9.9 ↖
7: 8.9 →
8: 10.2 ↑
9: *10.6 ←
10: 9.6 ↖
<b>Series 88.0</b>
<b>Total 0.0</b>

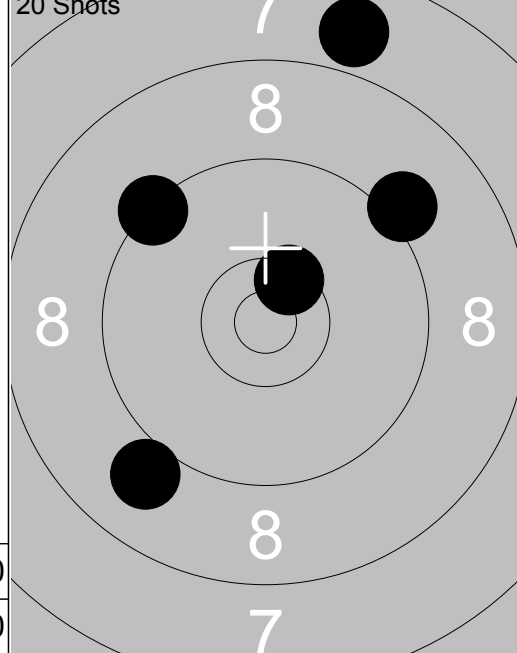

1: 9.1 ↗
2: *10.5 ↗
3: 9.3 ↖
4: 9.0 ↘
5: 7.9 ↑
<b>Series 44.0</b>
<b>Total 44.0</b>

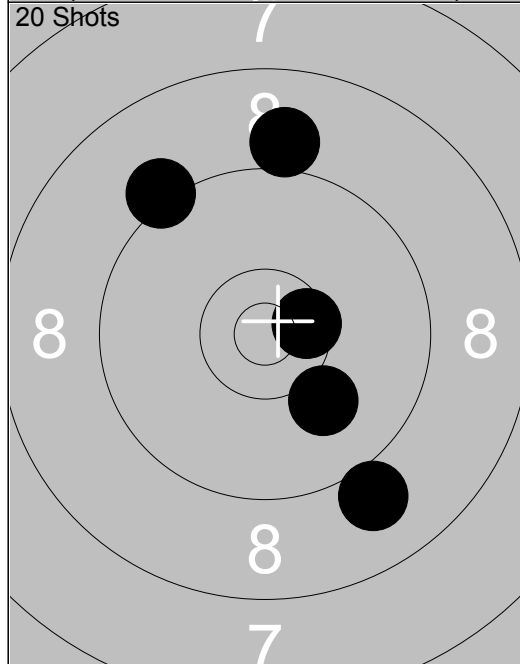

6: 9.0 ↑
7: 9.2 ↖
8: *10.5 →
9: 10.1 ↘
10: 9.0 ↘
<b>Series 47.0</b>
<b>Total 91.0</b>

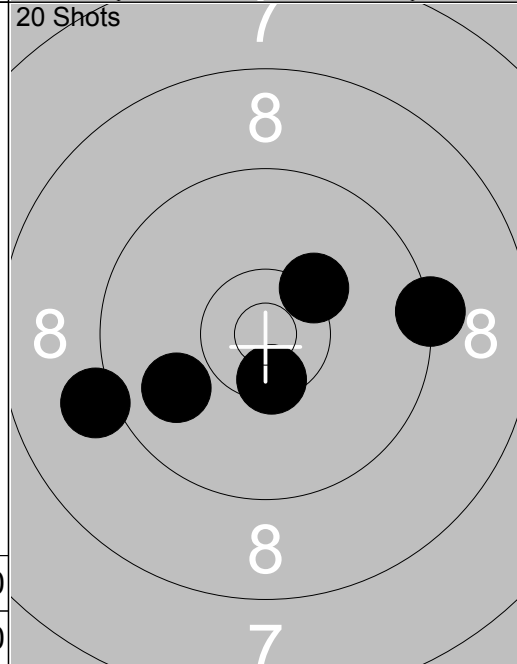

11: 9.1 ←
12: 9.9 ↖
13: 9.3 →
14: *10.5 ↘
15: 10.3 ↗
<b>Series 47.0</b>
<b>Total 138.0</b>

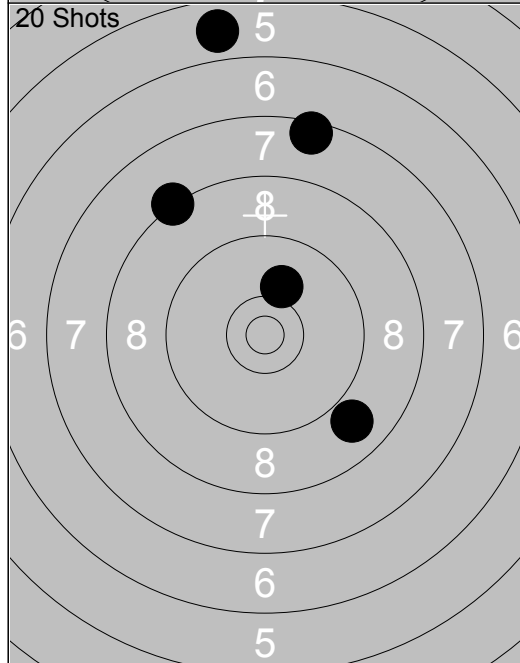

16: 8.3 ↖
17: 5.8 ↑
18: 10.1 ↑
19: 8.9 ↘
20: 7.5 ↑
<b>Series 38.0</b>
<b>Total 176.0</b>

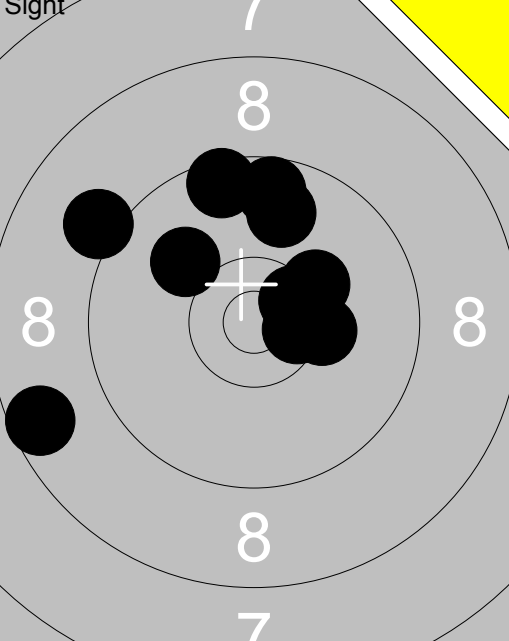
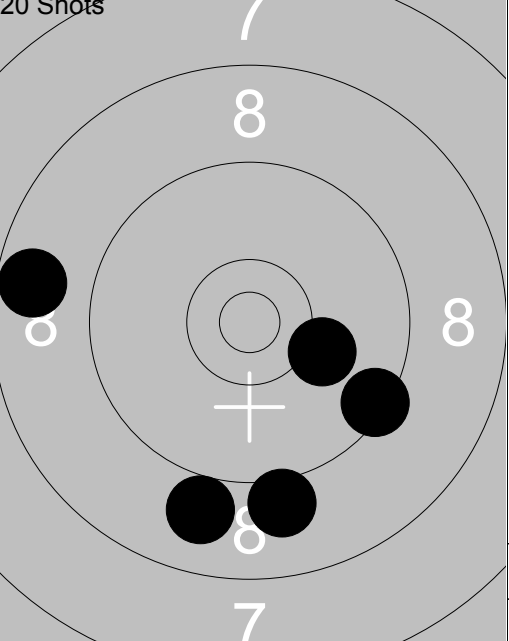
<p>Sight</p> 	<p>1: *10.5 ↗</p> <p>2: *10.5 →</p> <p>3: 9.1 ↖</p> <p>4: 10.2 ↗</p> <p>5: 9.6 ↑</p> <p>6: 8.6 ↙</p> <p>7: 10.3 →</p> <p>8: 10.0 ↖</p> <p>9: 9.5 ↑</p> <p>10: 9.8 ↑</p>	<p>20 Shots</p> 		<p>1: 9.4 ↘</p> <p>2: 10.1 →</p> <p>3: 8.7 ↖</p> <p>4: 9.0 ↓</p> <p>5: 9.1 ↓</p>
Series 94.0				Series 45.0
Total 0.0				Total 45.0

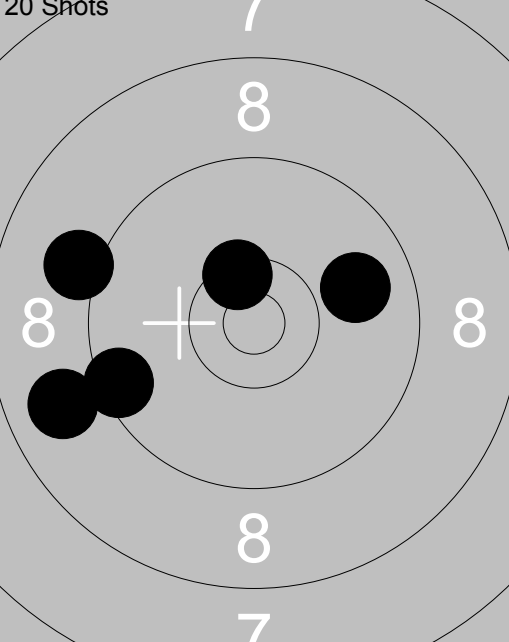
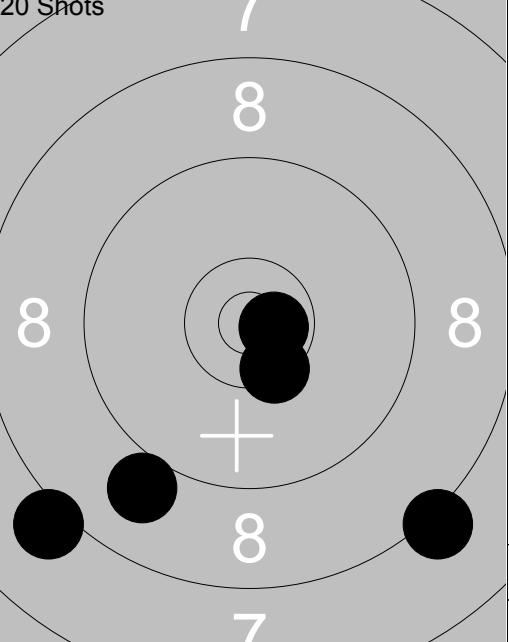
<p>20 Shots</p> 	<p>6: 9.9 →</p> <p>7: 9.1 ↖</p> <p>8: *10.4 ↗</p> <p>9: 8.9 ↖</p> <p>10: 9.5 ↖</p>	<p>20 Shots</p> 		<p>11: 8.2 ↘</p> <p>12: 8.1 ↖</p> <p>13: *10.4 ↘</p> <p>14: 9.0 ↖</p> <p>15: *10.7 →</p>
Series 45.0				Series 45.0
Total 90.0				Total 135.0

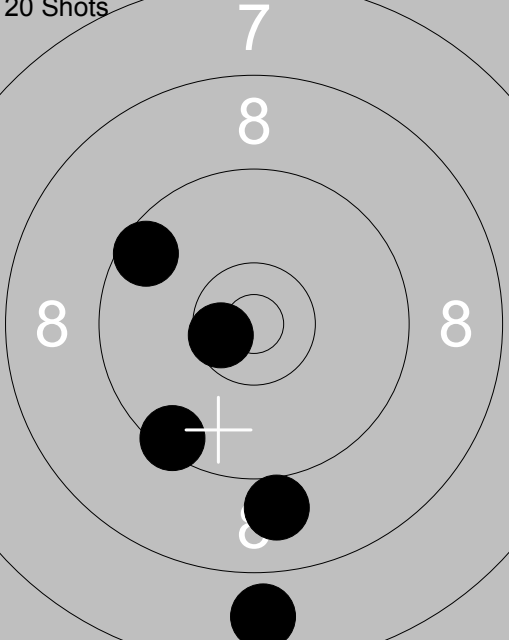
<p>20 Shots</p> 	<p>16: 9.0 ↓</p> <p>17: 7.8 ↓</p> <p>18: *10.6 ↖</p> <p>19: 9.5 ↖</p> <p>20: 9.6 ↖</p>			
Series 44.0				
Total 179.0				

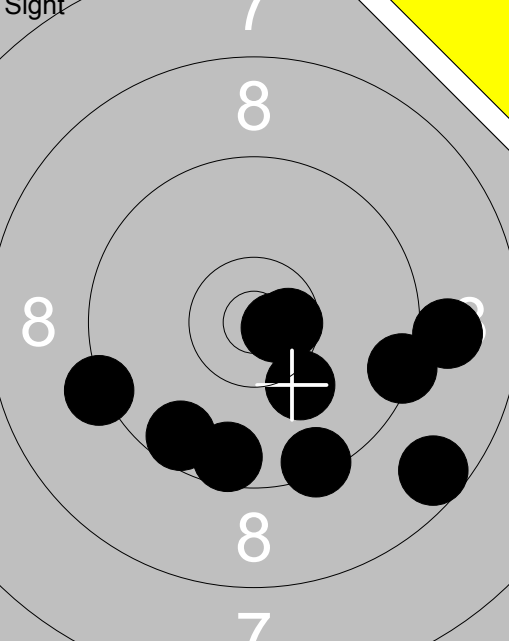
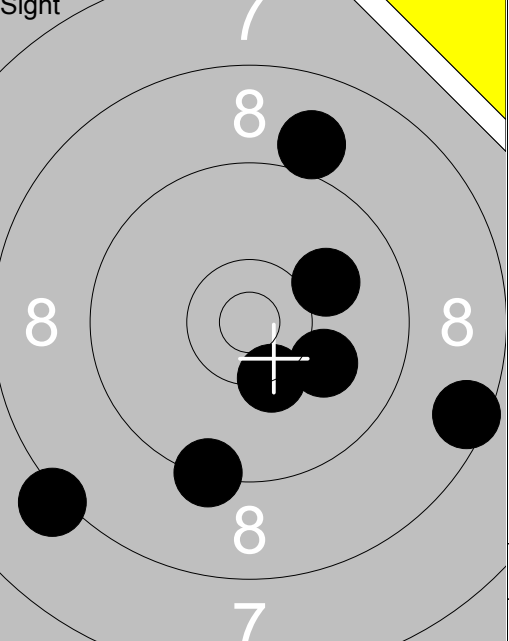
 <p>Sight</p>	<p>1: 9.4 ↓ 2: 10.2 ↓ 3: *10.7 → 4: 9.0 → 5: 9.6 ↓ 6: 9.6 ↓ 7: 8.6 ↓ 8: 9.4 → 9: 9.3 ← 10: *10.6 →</p> <p>Series 92.0 Total 0.0</p>	 <p>Sight</p>	<p>11: 9.3 ↓ 12: 10.1 → 13: 8.2 ↓ 14: 8.5 → 15: 10.1 → 16: *10.3 ↓ 17: 9.0 ↑</p> <p>Series 64.0 Total 0.0</p>
---	---	---	---

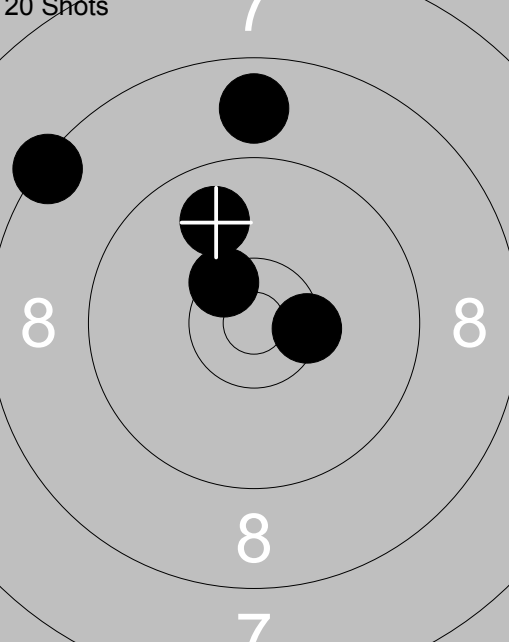
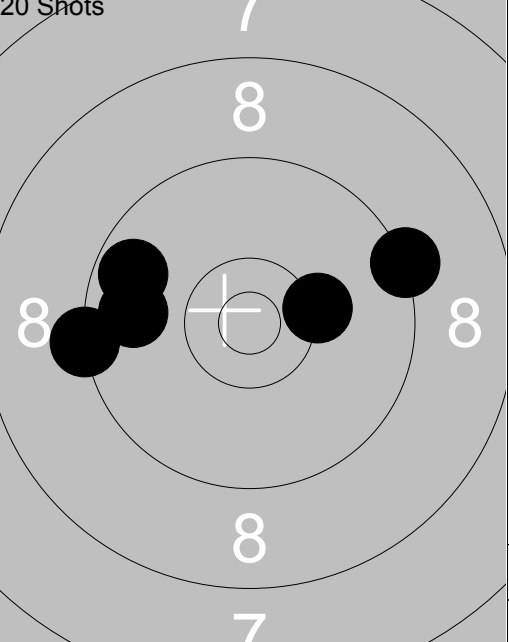
 <p>20 Shots</p>	<p>1: *10.4 → 2: *10.4 ↖ 3: 8.4 ↖ 4: 9.9 ↑ 5: 8.8 ↑</p> <p>Series 45.0 Total 45.0</p>	 <p>20 Shots</p>	<p>6: 10.3 → 7: 9.7 ↖ 8: 9.3 → 9: 9.3 ← 10: 9.8 ←</p> <p>Series 46.0 Total 91.0</p>
---	---	---	---

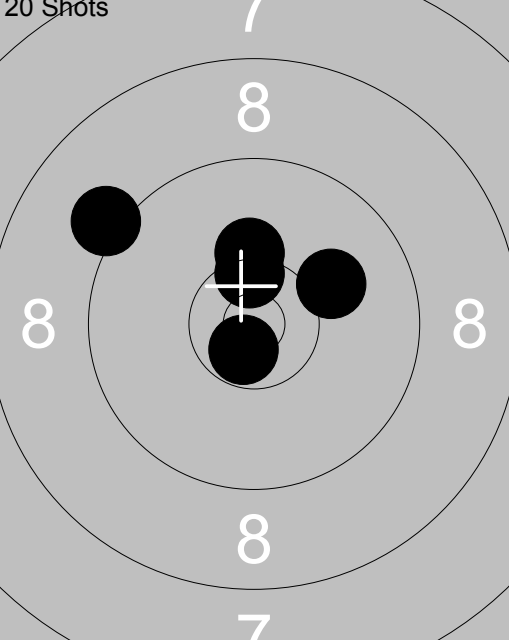
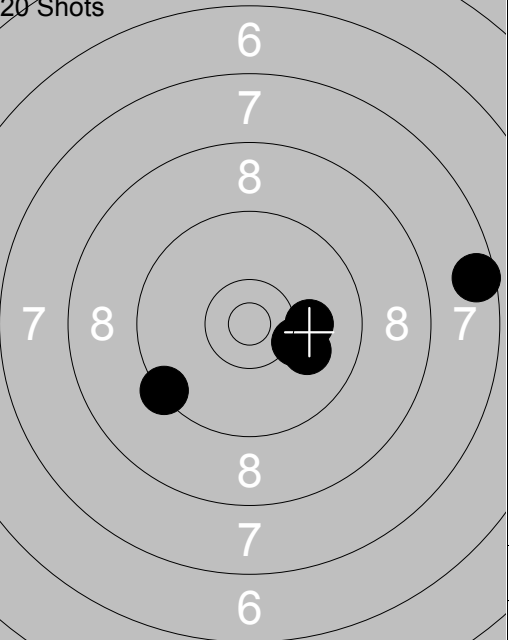
 <p>20 Shots</p>	<p>11: 10.2 ↑ 12: 9.2 ↖ 13: *10.7 ↓ 14: *10.4 ↑ 15: 10.1 →</p> <p>Series 49.0 Total 140.0</p>	 <p>20 Shots</p>	<p>16: 10.1 → 17: 10.2 → 18: 9.4 ↖ 19: 7.6 → 20: 10.0 →</p> <p>Series 46.0 Total 186.0</p>
--	---	--	--

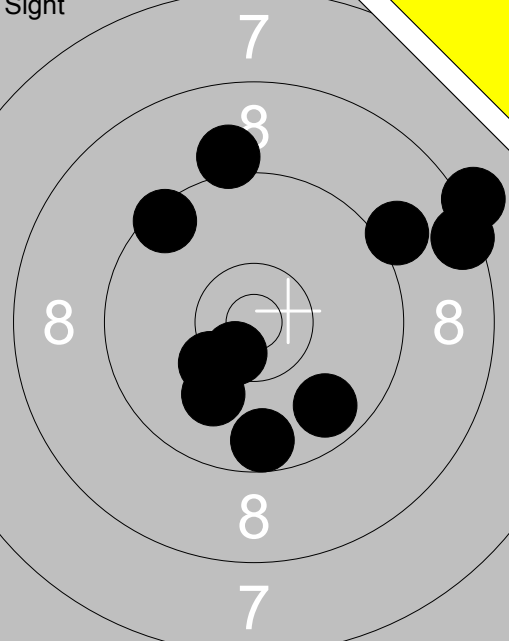
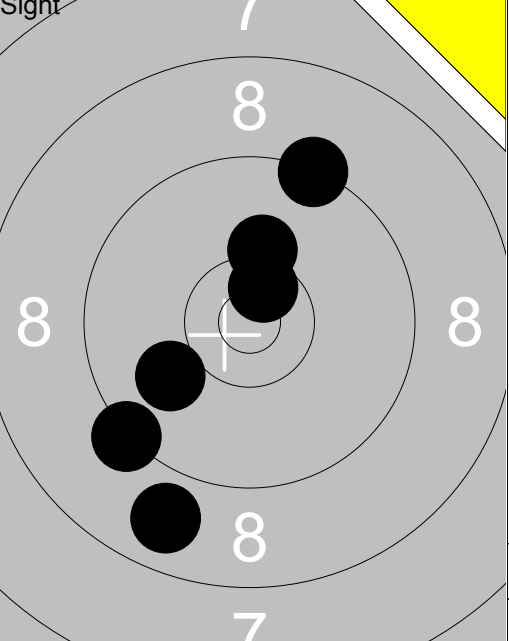

 <p style="text-align:center;">Sight</p>	<p>1: 9.1 →</p> <p>2: 8.5 →</p> <p>3: 8.2 →</p> <p>4: 10.3 ↙</p> <p>5: 9.6 ↓</p> <p>6: 9.7 ↓</p> <p>7: *10.6 ↙</p> <p>8: 10.0 ↙</p> <p>9: 9.5 ↖</p> <p>10: 9.1 ↑</p>	 <p style="text-align:center;">Sight</p>	<p>11: *10.6 ↗</p> <p>12: 9.3 ↗</p> <p>13: 8.8 ↘</p> <p>14: 10.0 ↙</p> <p>15: 9.3 ↙</p> <p>16: 10.2 ↗</p>
Series 91.0	Total 0.0	Series 56.0	Total 0.0

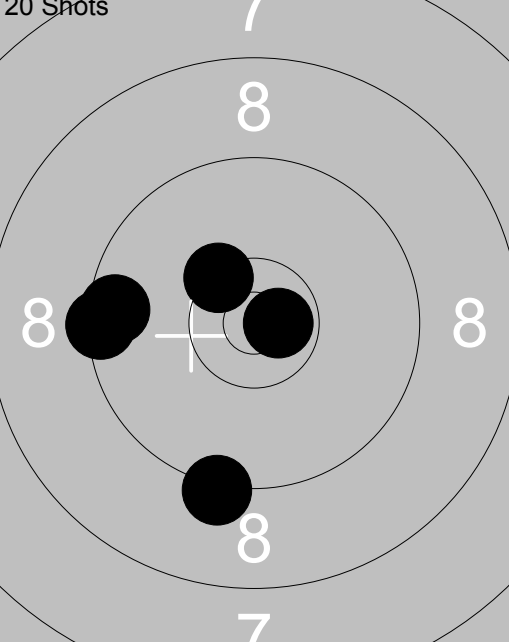
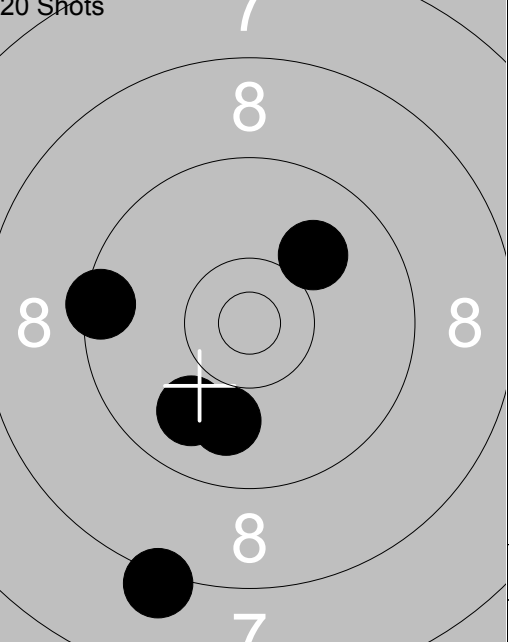
 <p style="text-align:center;">20 Shots</p>	<p>1: 9.6 ←</p> <p>2: *10.7 →</p> <p>3: 9.2 ↓</p> <p>4: 9.4 ←</p> <p>5: *10.4 ↗</p>	 <p style="text-align:center;">20 Shots</p>	<p>6: 9.5 ←</p> <p>7: 9.9 ↓</p> <p>8: 9.9 ↙</p> <p>9: 8.2 ↓</p> <p>10: 10.0 ↗</p>
Series 47.0	Total 47.0	Series 45.0	Total 92.0

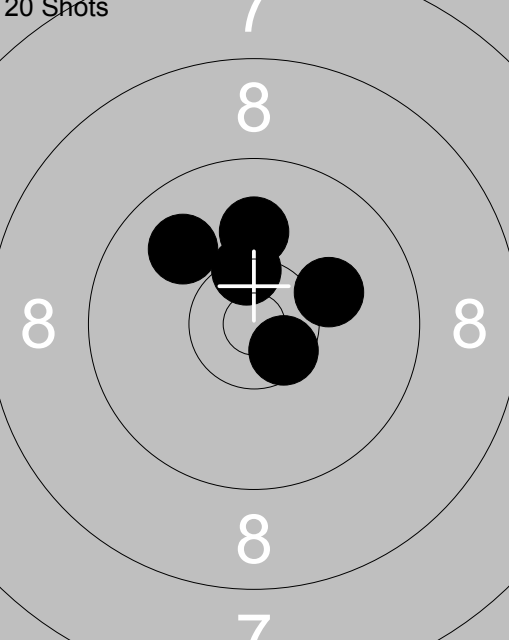
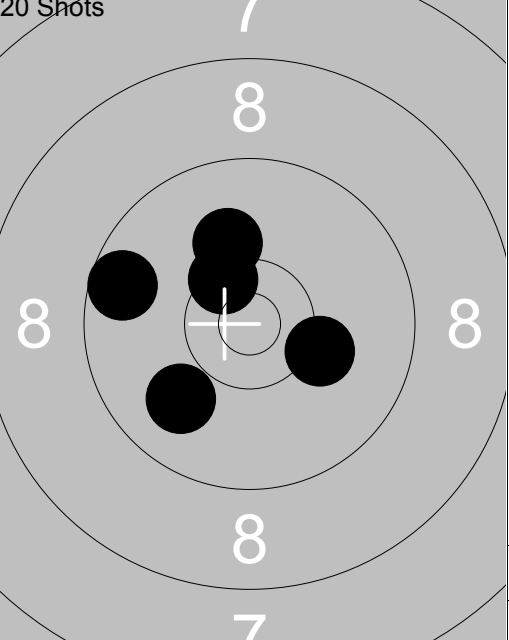
 <p style="text-align:center;">20 Shots</p>	<p>11: *10.4 ↗</p> <p>12: 10.1 →</p> <p>13: 10.0 ↑</p> <p>14: 9.9 ↖</p> <p>15: *10.6 ↘</p>	 <p style="text-align:center;">20 Shots</p>	<p>16: 9.9 ↙</p> <p>17: 10.1 ↗</p> <p>18: 9.6 ←</p> <p>19: *10.4 ↗</p> <p>20: 10.2 →</p>
Series 49.0	Total 141.0	Series 48.0	Total 189.0

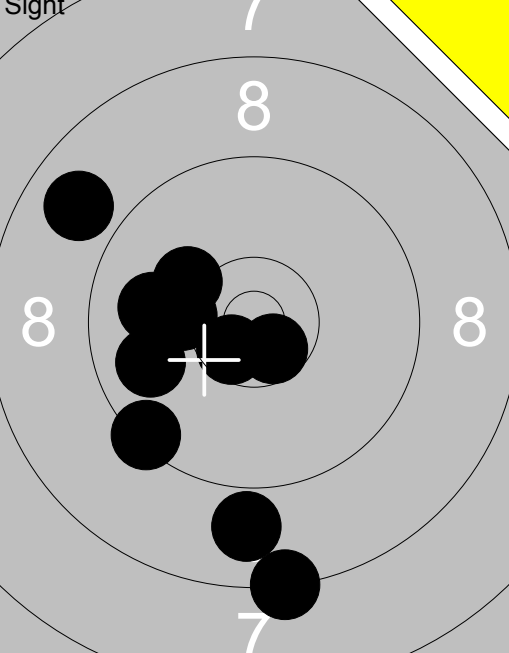
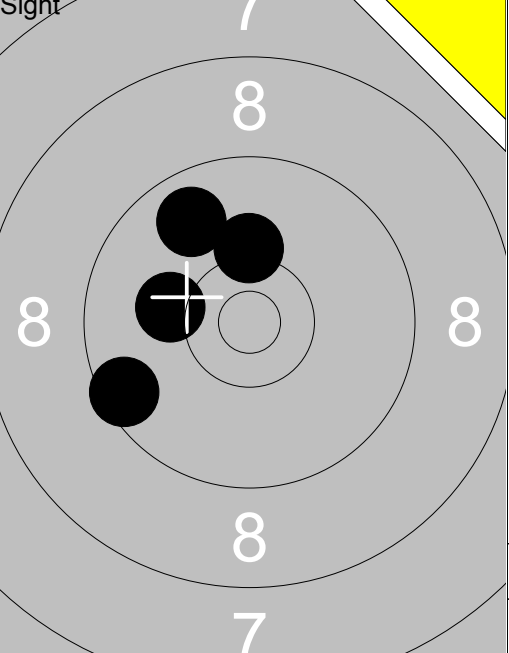
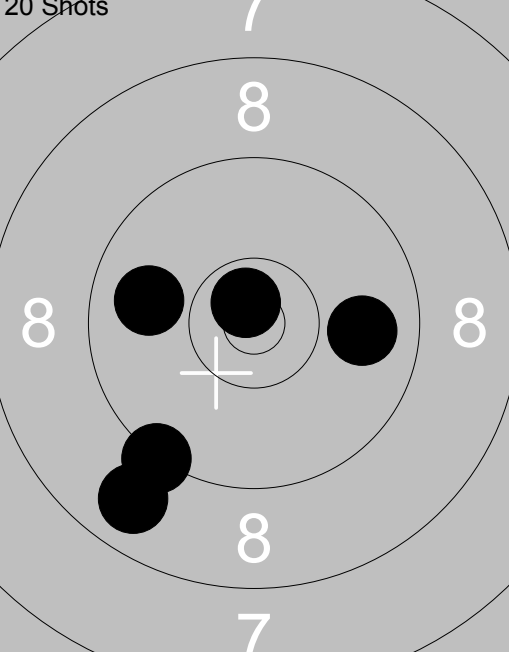
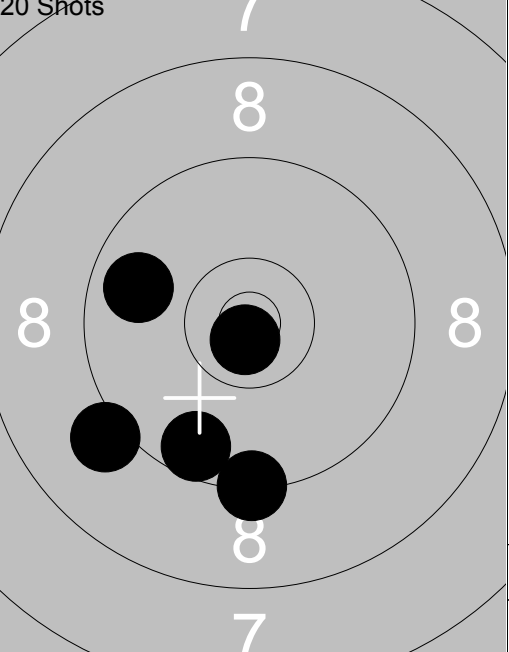
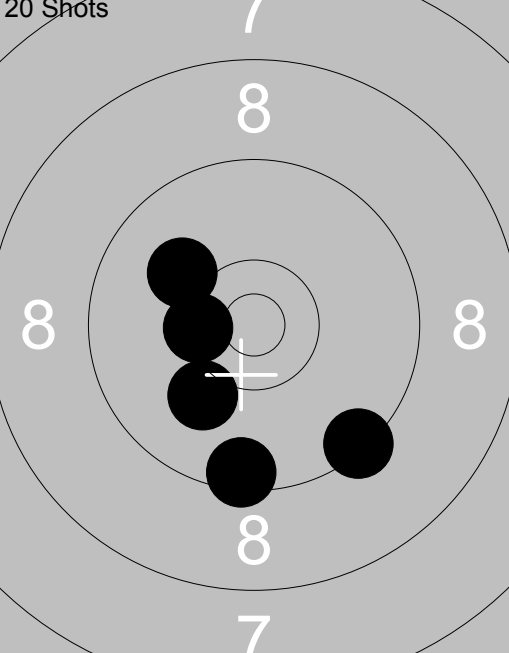
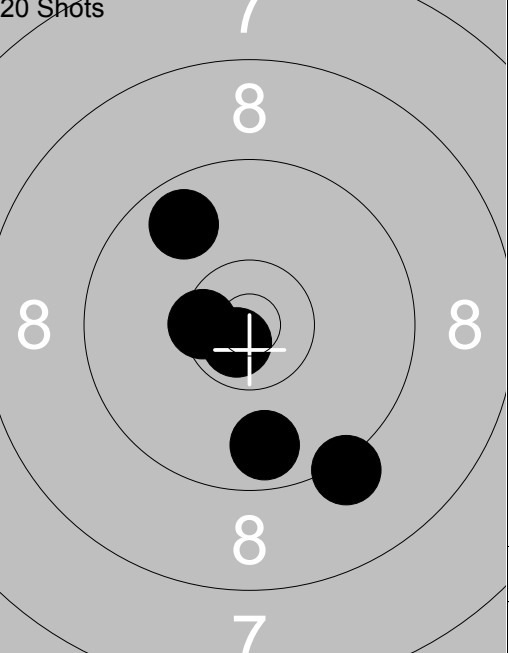
<p>Sight</p> 	<p>1: 8.8 ↖ 2: 8.9 ↓ 3: 10.2 ↖ 4: 10.2 ← 5: 8.3 ↓ 6: *10.6 ↘ 7: 9.9 ← 8: 9.4 ↘ 9: 9.8 ← 10: *10.6 ↘</p> <p>Series 91.0 Total 0.0</p>	<p>Sight</p> 	<p>11: 9.5 ↖ 12: 10.1 ← 13: 9.8 ↖ 14: 10.2 ↑</p> <p>Series 38.0 Total 0.0</p>
<p>20 Shots</p> 	<p>1: 9.9 → 2: 8.8 ↘ 3: 9.3 ↘ 4: 9.9 ← 5: *10.7 ↗</p> <p>Series 45.0 Total 45.0</p>	<p>20 Shots</p> 	<p>6: 9.3 ↓ 7: 9.6 ↘ 8: *10.8 ↘ 9: 9.1 ← 10: 9.8 ←</p> <p>Series 46.0 Total 91.0</p>
<p>20 Shots</p> 	<p>11: 9.5 ↓ 12: 10.1 ↖ 13: 10.1 ↘ 14: *10.4 ← 15: 9.4 ↘</p> <p>Series 48.0 Total 139.0</p>	<p>20 Shots</p> 	<p>16: *10.5 ← 17: 9.7 ↖ 18: *10.7 ↘ 19: 9.7 ↓ 20: 9.2 ↘</p> <p>Series 47.0 Total 186.0</p>

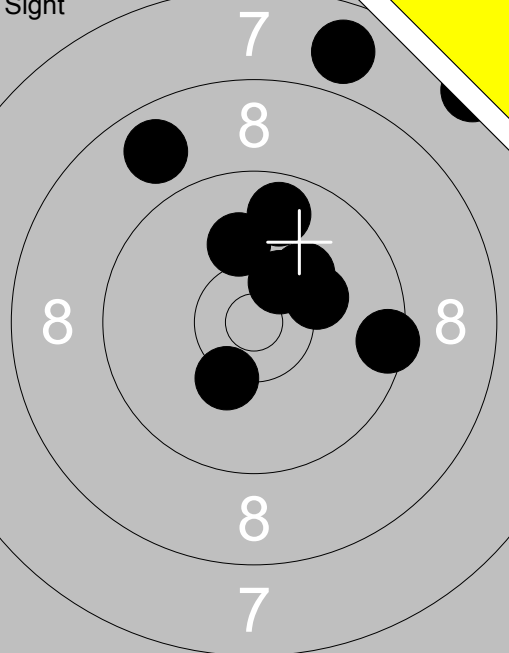
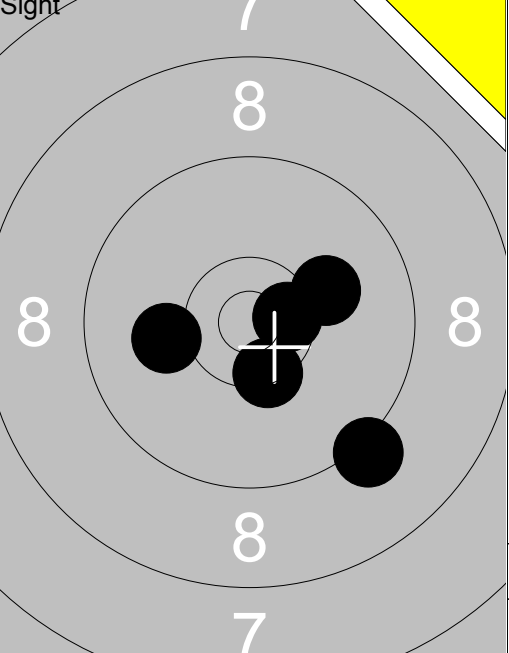
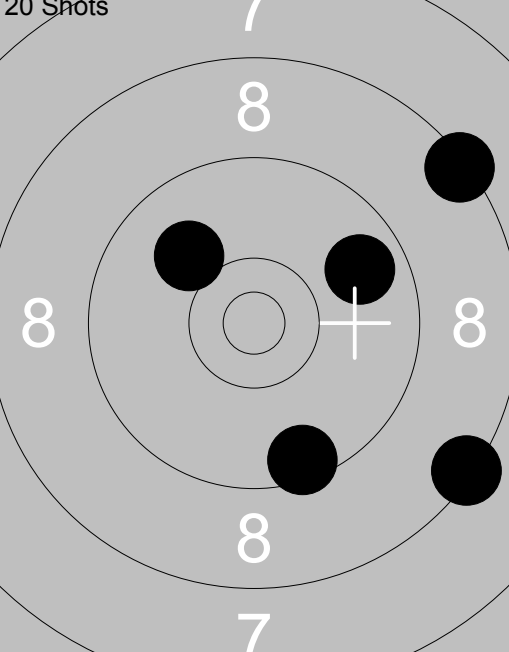
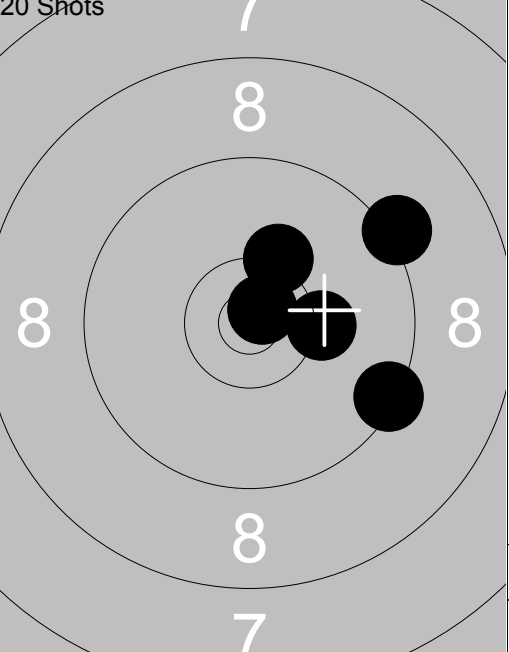
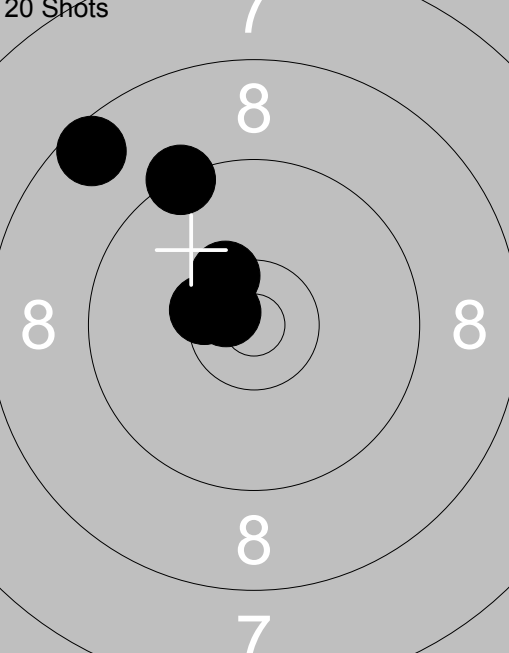
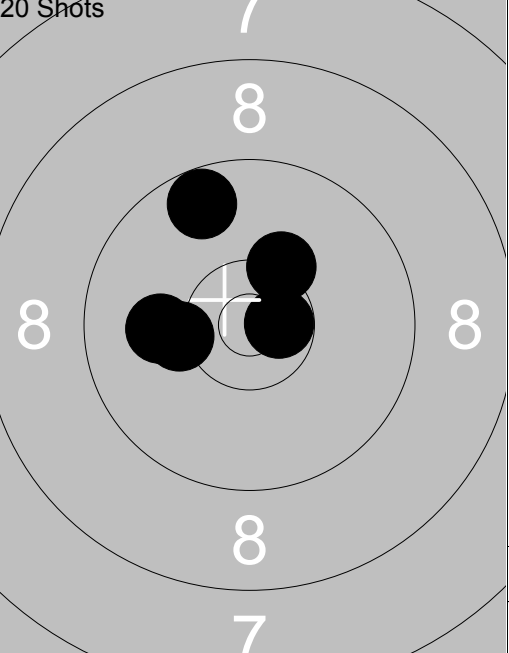
<p>Sight</p> 	<p>1: 7.5 ↗ 2: 7.8 ↑ 3: 9.7 ↑ 4: 9.5 → 5: 8.8 ↖ 6: 10.2 → 7: 10.1 ↑ 8: 10.2 ↗ 9: 10.3 ↓ 10: *10.4 ↗</p> <table border="1" style="width:100%; border-collapse: collapse;"> <tr><td>Series</td><td style="text-align:right;">90.0</td></tr> <tr><td>Total</td><td style="text-align:right;">0.0</td></tr> </table>	Series	90.0	Total	0.0	<p>Sight</p> 	<p>11: 9.2 ↓ 12: *10.4 ↓ 13: 10.1 ← 14: 10.1 → 15: *10.6 →</p> <table border="1" style="width:100%; border-collapse: collapse;"> <tr><td>Series</td><td style="text-align:right;">49.0</td></tr> <tr><td>Total</td><td style="text-align:right;">0.0</td></tr> </table>	Series	49.0	Total	0.0
Series	90.0										
Total	0.0										
Series	49.0										
Total	0.0										
<p>20 Shots</p> 	<p>1: 9.5 ↓ 2: 8.4 ↓ 3: 9.8 → 4: 10.0 ↖ 5: 8.4 →</p> <table border="1" style="width:100%; border-collapse: collapse;"> <tr><td>Series</td><td style="text-align:right;">44.0</td></tr> <tr><td>Total</td><td style="text-align:right;">44.0</td></tr> </table>	Series	44.0	Total	44.0	<p>20 Shots</p> 	<p>6: 10.2 ↑ 7: *10.8 ↗ 8: 9.4 → 9: 9.2 ↗ 10: 10.2 →</p> <table border="1" style="width:100%; border-collapse: collapse;"> <tr><td>Series</td><td style="text-align:right;">48.0</td></tr> <tr><td>Total</td><td style="text-align:right;">92.0</td></tr> </table>	Series	48.0	Total	92.0
Series	44.0										
Total	44.0										
Series	48.0										
Total	92.0										
<p>20 Shots</p> 	<p>11: *10.6 ↖ 12: *10.4 ↖ 13: 9.3 ↑ 14: 8.6 ↖ 15: *10.4 ↖</p> <table border="1" style="width:100%; border-collapse: collapse;"> <tr><td>Series</td><td style="text-align:right;">47.0</td></tr> <tr><td>Total</td><td style="text-align:right;">139.0</td></tr> </table>	Series	47.0	Total	139.0	<p>20 Shots</p> 	<p>16: *10.3 ↗ 17: 10.1 ← 18: 9.7 ↖ 19: 10.2 ← 20: *10.7 →</p> <table border="1" style="width:100%; border-collapse: collapse;"> <tr><td>Series</td><td style="text-align:right;">49.0</td></tr> <tr><td>Total</td><td style="text-align:right;">188.0</td></tr> </table>	Series	49.0	Total	188.0
Series	47.0										
Total	139.0										
Series	49.0										
Total	188.0										

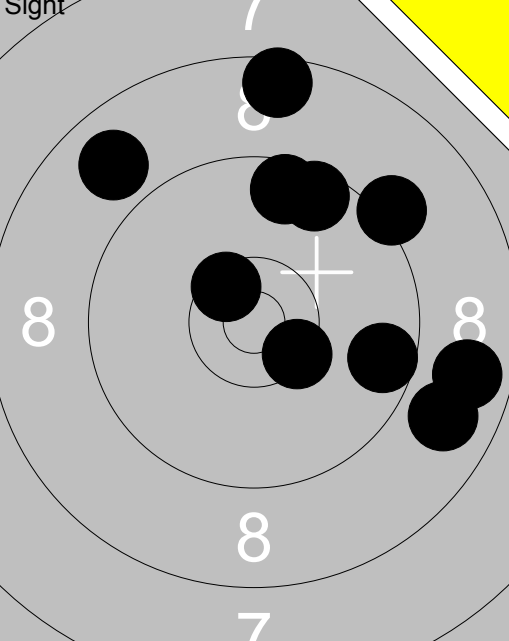
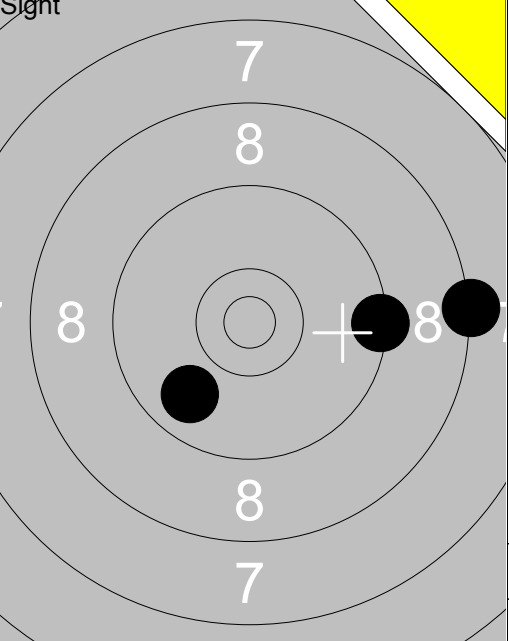
	<p>1: 8.6 ↑</p> <p>2: 8.8 ↗</p> <p>3: 8.8 →</p> <p>4: *10.4 ↘</p> <p>5: 9.2 ↗</p> <p>6: 9.6 →</p> <p>7: 9.6 ↑</p> <p>8: *10.5 ↘</p> <p>9: 8.8 →</p> <p>10: 9.6 ↑</p> <hr/> <p>Series 88.0</p> <p>Total 0.0</p>		<p>11: 9.8 ↘</p> <p>12: 8.3 →</p> <p>13: 9.4 →</p> <hr/> <p>Series 26.0</p> <p>Total 0.0</p>
--	--	--	--

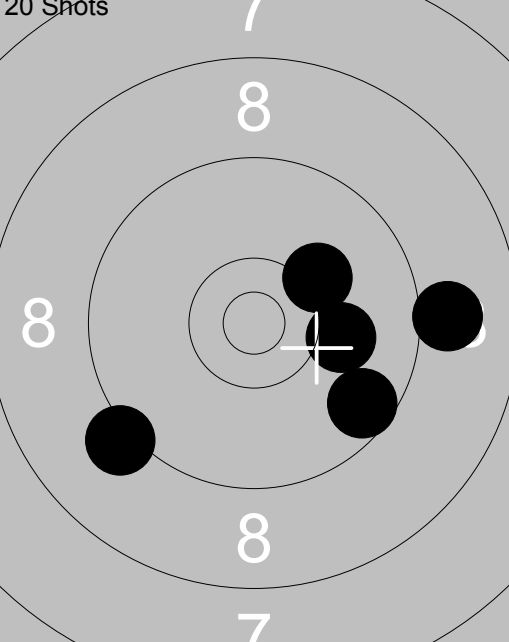
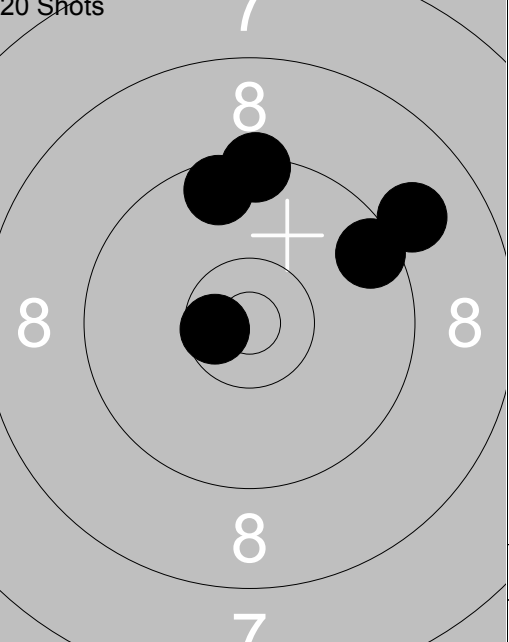
	<p>1: 10.1 →</p> <p>2: 9.2 ↘</p> <p>3: 10.2 ↗</p> <p>4: 9.0 →</p> <p>5: 9.6 ↘</p> <hr/> <p>Series 47.0</p> <p>Total 47.0</p>		<p>6: 9.4 ↑</p> <p>7: 9.0 ↗</p> <p>8: *10.6 ↘</p> <p>9: 9.6 ↗</p> <p>10: 9.6 ↑</p> <hr/> <p>Series 46.0</p> <p>Total 93.0</p>
---	--	---	---

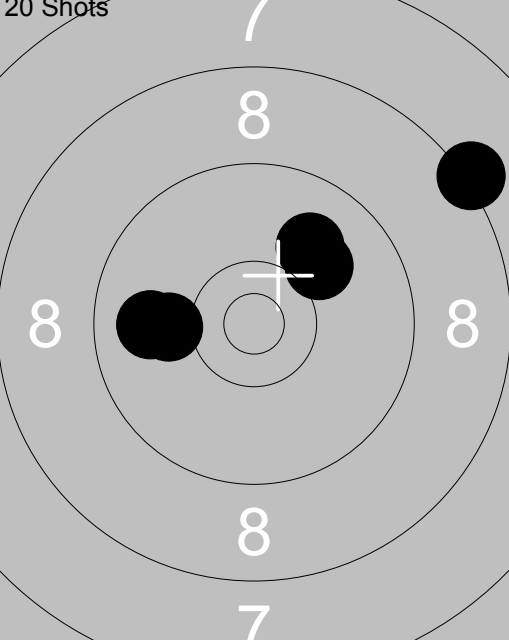
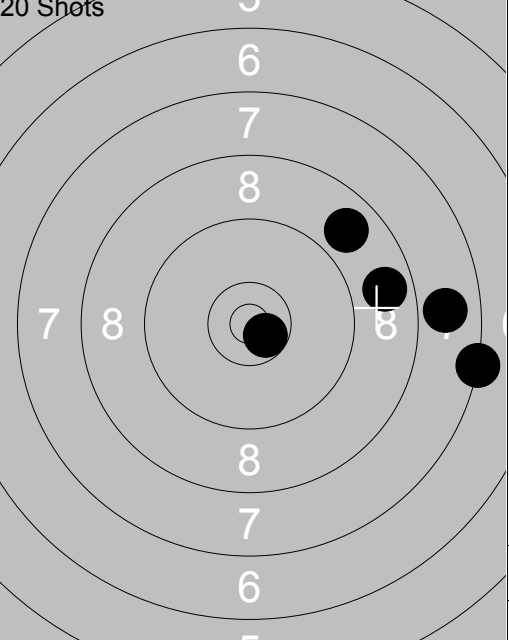
	<p>11: 9.9 ←</p> <p>12: 10.0 ↗</p> <p>13: 10.0 ↗</p> <p>14: 8.2 ↗</p> <p>15: 10.1 ←</p> <hr/> <p>Series 47.0</p> <p>Total 140.0</p>		<p>16: 7.9 →</p> <p>17: 7.3 →</p> <p>18: 8.7 →</p> <p>19: 8.8 ↗</p> <p>20: *10.6 ↘</p> <hr/> <p>Series 40.0</p> <p>Total 180.0</p>
--	---	--	--

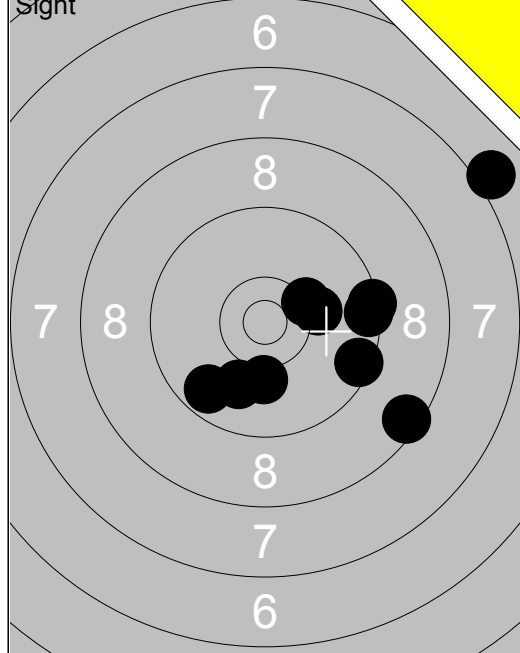

1:	7.1	↗
2:	8.5	→
3:	9.5	→
4:	10.1	↓
5:	10.2	→
6:	9.4	→
7:	*10.3	↗
8:	10.0	↓
9:	9.7	↙
10:	9.5	→
Series	91.0	
Total	0.0	

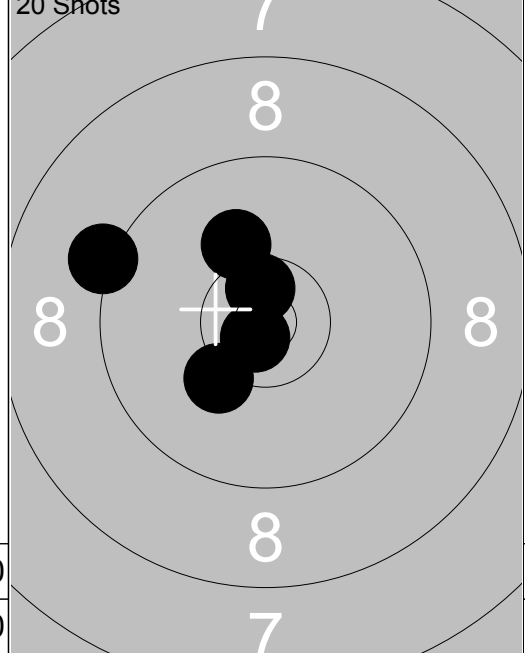

1:	*10.8	↙
2:	10.2	↙
3:	9.2	↖
4:	*10.6	↗
5:	10.1	↗
Series	49.0	
Total	49.0	

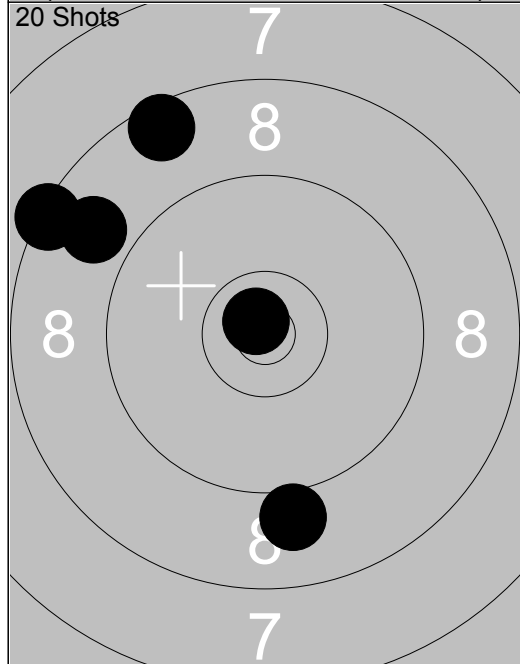

6:	*10.8	↖
7:	8.5	↗
8:	8.4	↖
9:	8.9	↖
10:	9.0	↓
Series	43.0	
Total	92.0	

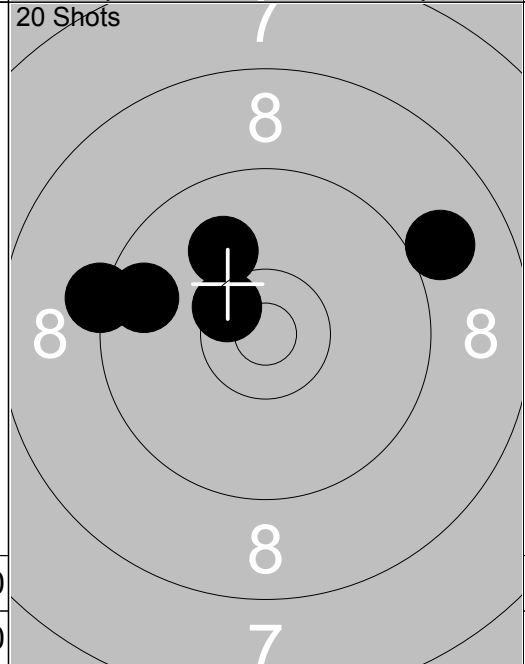

11:	10.0	↖
12:	9.7	↖
13:	9.0	↗
14:	*10.5	↖
15:	9.3	↖
Series	47.0	
Total	139.0	

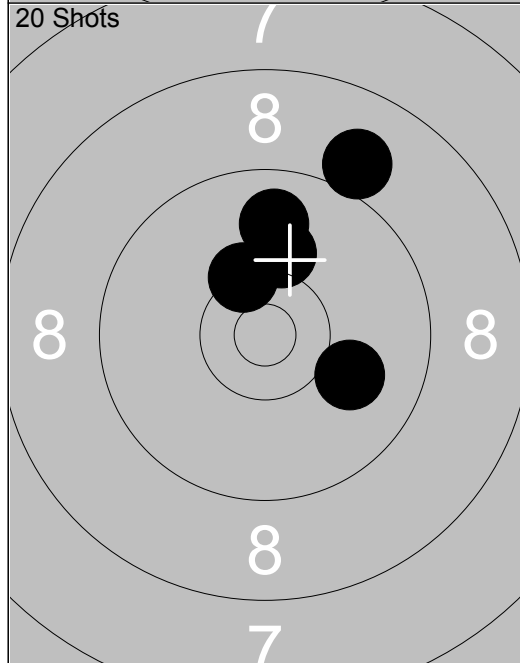

16:	10.1	↑
17:	9.0	↗
18:	*10.3	↖
19:	10.0	→
20:	9.8	↑
Series	48.0	
Total	187.0	

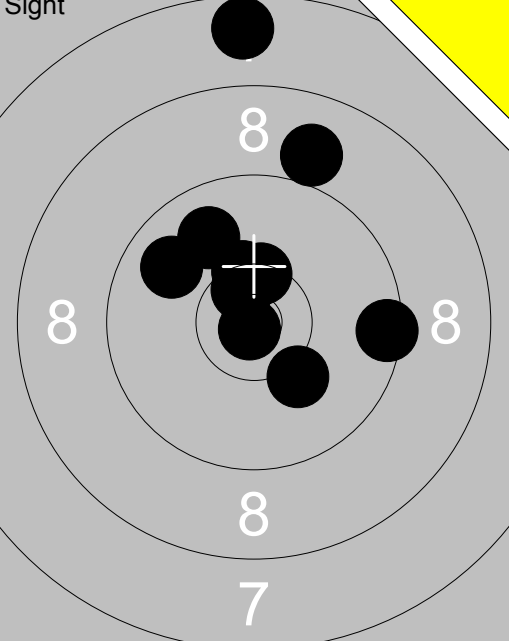
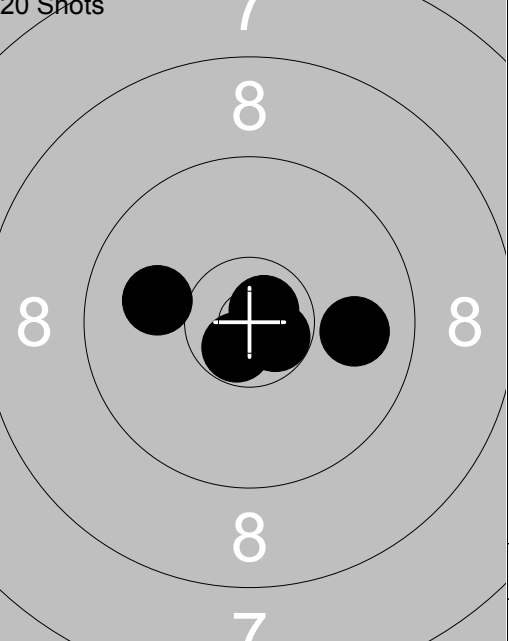
 <p>Sight</p>	<p>1: 7.7 ↑</p> <p>2: 9.0 ↑</p> <p>3: 9.8 ↖</p> <p>4: *10.4↑</p> <p>5: 9.9 ↖</p> <p>6: *10.4↑</p> <p>7: *10.9↘</p> <p>8: 10.2 ↘</p> <p>9: 9.5 →</p> <p>10: *10.6↖</p>	<p>20 Shots</p> 	<p>1: *10.8↗</p> <p>2: *10.7↘</p> <p>3: *10.7↘</p> <p>4: 10.0↖</p> <p>5: 9.9 →</p>
Series 93.0		Series 49.0	
Total 0.0		Total 49.0	

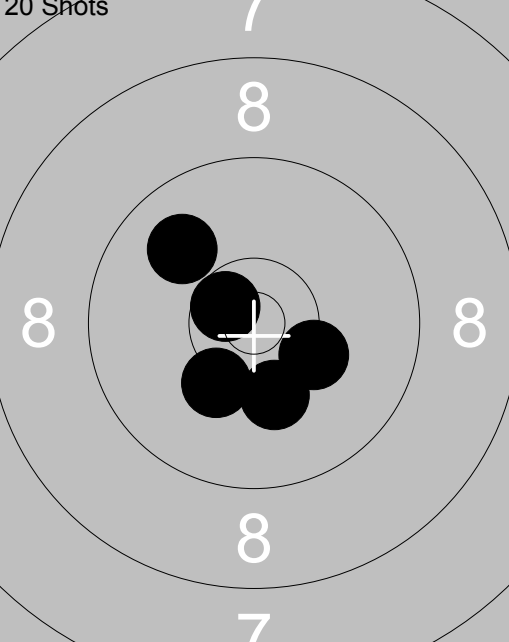
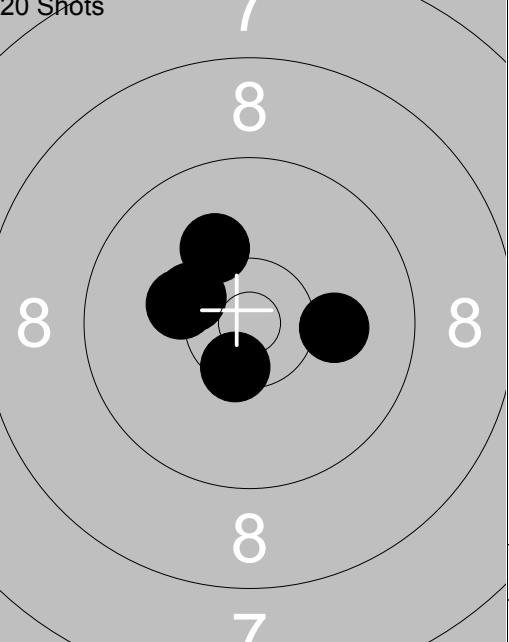
<p>20 Shots</p> 	<p>6: 10.2 ↘</p> <p>7: 10.2 ↘</p> <p>8: 10.3 ↘</p> <p>9: 9.9 ↖</p> <p>10: *10.6↖</p>	<p>20 Shots</p> 	<p>11: *10.3↖</p> <p>12: 10.2↖</p> <p>13: *10.5↘</p> <p>14: 10.1→</p> <p>15: 10.1 ↖</p>
Series 49.0		Series 50.0	
Total 98.0		Total 148.0	

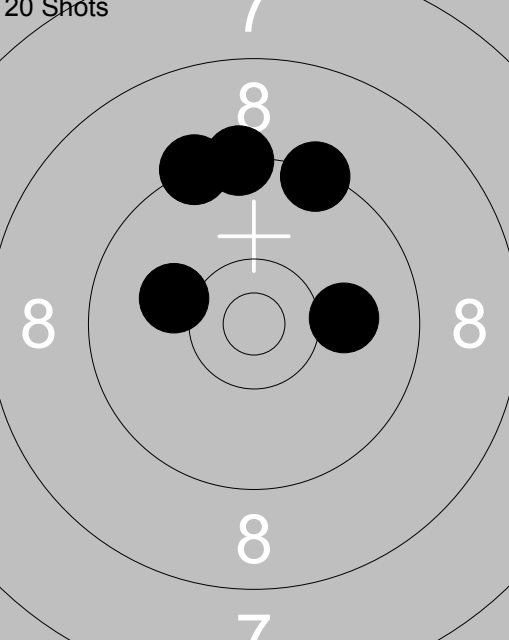
<p>20 Shots</p> 	<p>16: 9.3 ↑</p> <p>17: 9.4 ↑</p> <p>18: 10.0→</p> <p>19: 9.3 ↖</p> <p>20: 10.1↖</p>	
Series 47.0		
Total 195.0		

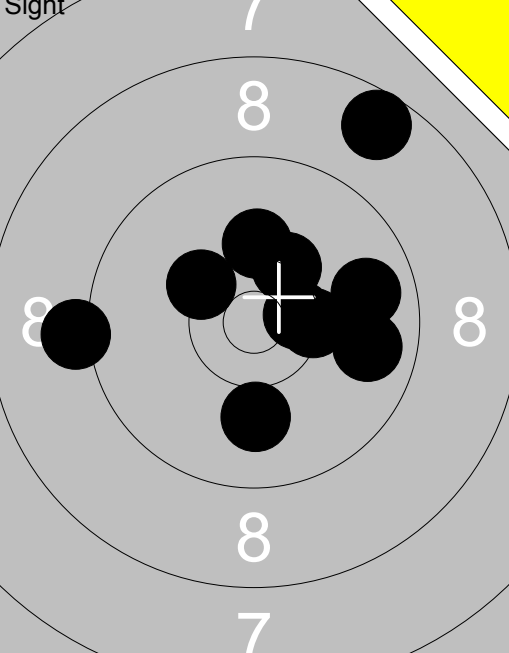
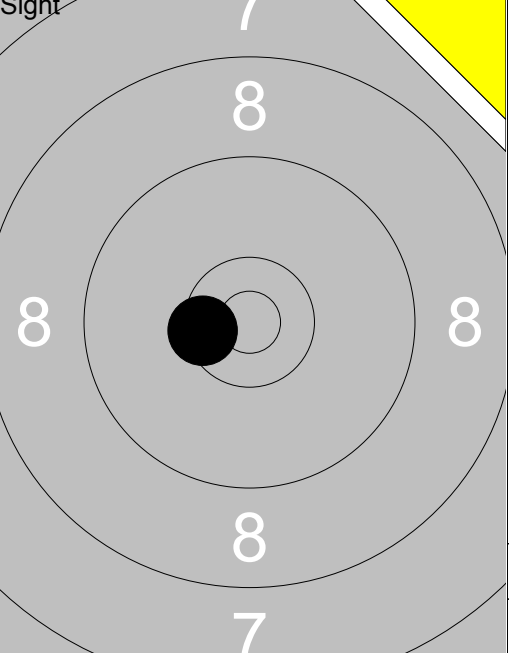
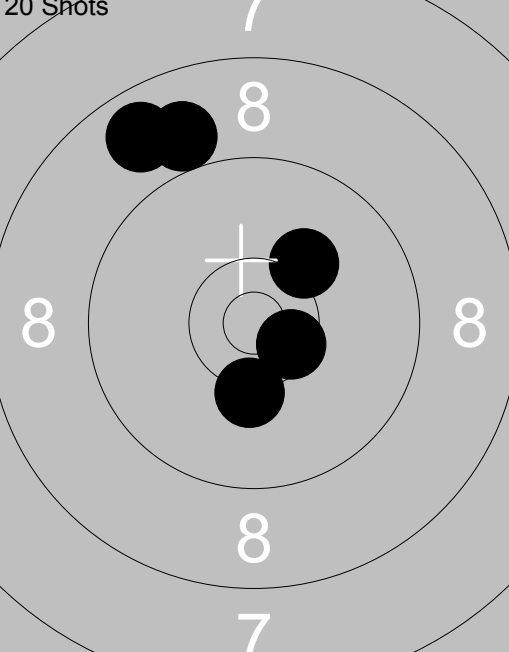
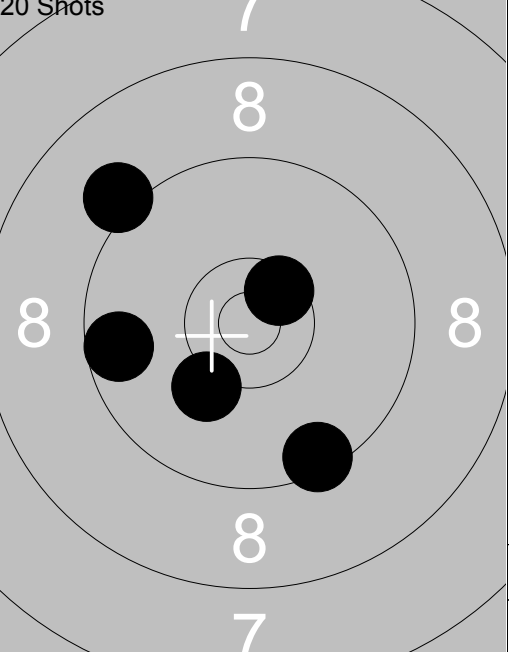
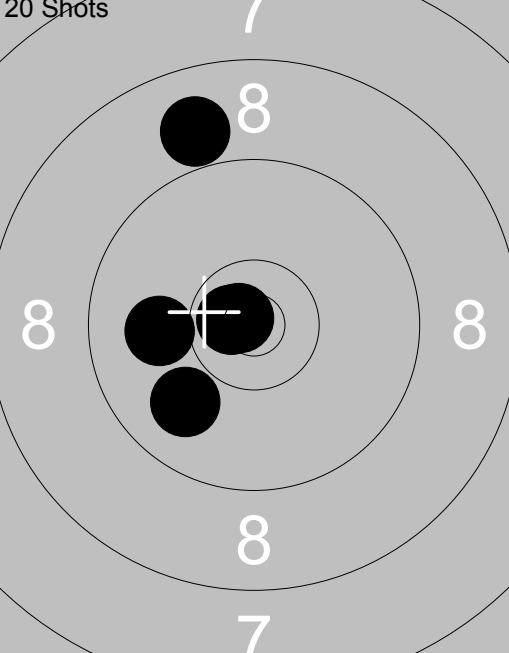
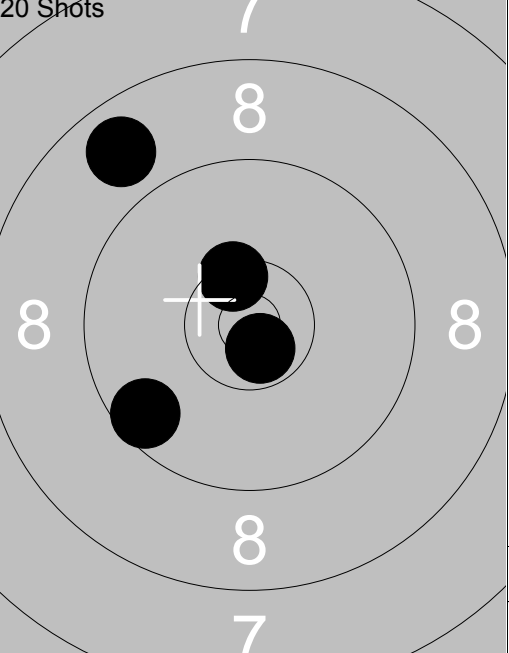
<p>Sight</p> 	<p>Sight</p> 	<table style="width:100%; border-collapse: collapse;"> <tr><td>1: 9.2 ←</td><td>11: *10.5 ↖</td></tr> <tr><td>2: 10.0 ↓</td><td></td></tr> <tr><td>3: 9.8 →</td><td></td></tr> <tr><td>4: *10.5 →</td><td></td></tr> <tr><td>5: *10.3 ↗</td><td></td></tr> <tr><td>6: 9.8 →</td><td></td></tr> <tr><td>7: 8.6 ↗</td><td></td></tr> <tr><td>8: *10.4 →</td><td></td></tr> <tr><td>9: 10.2 ↑</td><td></td></tr> <tr><td>10: *10.3 ↖</td><td></td></tr> <tr><td colspan="2" style="border-top: 1px solid black;">Series 95.0</td></tr> <tr><td colspan="2" style="border-top: 1px solid black;">Total 0.0</td></tr> </table>	1: 9.2 ←	11: *10.5 ↖	2: 10.0 ↓		3: 9.8 →		4: *10.5 →		5: *10.3 ↗		6: 9.8 →		7: 8.6 ↗		8: *10.4 →		9: 10.2 ↑		10: *10.3 ↖		Series 95.0		Total 0.0	
1: 9.2 ←	11: *10.5 ↖																									
2: 10.0 ↓																										
3: 9.8 →																										
4: *10.5 →																										
5: *10.3 ↗																										
6: 9.8 →																										
7: 8.6 ↗																										
8: *10.4 →																										
9: 10.2 ↑																										
10: *10.3 ↖																										
Series 95.0																										
Total 0.0																										
<p>20 Shots</p> 	<p>20 Shots</p> 	<table style="width:100%; border-collapse: collapse;"> <tr><td>1: *10.5 ↘</td><td>6: 9.1 ↖</td></tr> <tr><td>2: 10.2 ↗</td><td>7: 10.2 ↓</td></tr> <tr><td>3: 10.3 ↓</td><td>8: 9.5 ↓</td></tr> <tr><td>4: 8.8 ↖</td><td>9: *10.5 ↗</td></tr> <tr><td>5: 9.0 ↗</td><td>10: 9.6 ←</td></tr> <tr><td colspan="2" style="border-top: 1px solid black;">Series 47.0</td></tr> <tr><td colspan="2" style="border-top: 1px solid black;">Total 47.0</td></tr> </table>	1: *10.5 ↘	6: 9.1 ↖	2: 10.2 ↗	7: 10.2 ↓	3: 10.3 ↓	8: 9.5 ↓	4: 8.8 ↖	9: *10.5 ↗	5: 9.0 ↗	10: 9.6 ←	Series 47.0		Total 47.0											
1: *10.5 ↘	6: 9.1 ↖																									
2: 10.2 ↗	7: 10.2 ↓																									
3: 10.3 ↓	8: 9.5 ↓																									
4: 8.8 ↖	9: *10.5 ↗																									
5: 9.0 ↗	10: 9.6 ←																									
Series 47.0																										
Total 47.0																										
<p>20 Shots</p> 	<p>20 Shots</p> 	<table style="width:100%; border-collapse: collapse;"> <tr><td>11: *10.8 ↖</td><td>16: 9.6 ↖</td></tr> <tr><td>12: 8.9 ↗</td><td>17: 8.8 ↖</td></tr> <tr><td>13: 10.0 ←</td><td>18: 0.0</td></tr> <tr><td>14: 9.9 ↘</td><td>19: *10.4 ↗</td></tr> <tr><td>15: *10.7 ↖</td><td>20: *10.7 ↓</td></tr> <tr><td colspan="2" style="border-top: 1px solid black;">Series 47.0</td></tr> <tr><td colspan="2" style="border-top: 1px solid black;">Total 141.0</td></tr> </table>	11: *10.8 ↖	16: 9.6 ↖	12: 8.9 ↗	17: 8.8 ↖	13: 10.0 ←	18: 0.0	14: 9.9 ↘	19: *10.4 ↗	15: *10.7 ↖	20: *10.7 ↓	Series 47.0		Total 141.0											
11: *10.8 ↖	16: 9.6 ↖																									
12: 8.9 ↗	17: 8.8 ↖																									
13: 10.0 ←	18: 0.0																									
14: 9.9 ↘	19: *10.4 ↗																									
15: *10.7 ↖	20: *10.7 ↓																									
Series 47.0																										
Total 141.0																										

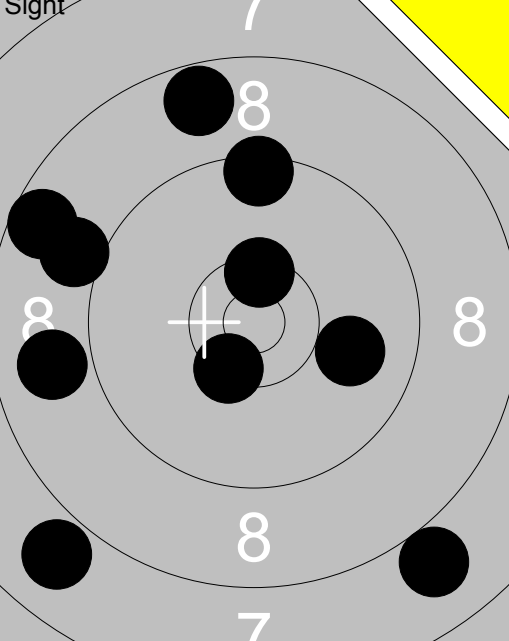
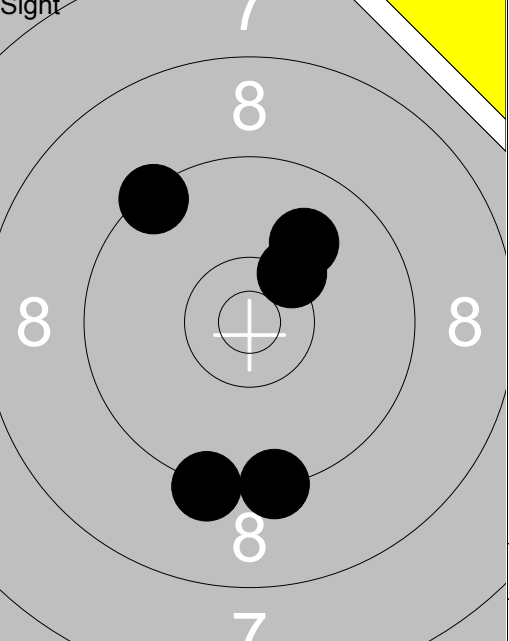
	1: 8.6 ↙		11: *10.3 ↗
	2: 8.9 ←		12: 9.3 ↓
	3: *10.4 ↘		13: 9.4 ↖
	4: 9.0 ↖		14: 9.3 ↓
	5: 9.4 ↑		15: 10.0 ↗
	6: 7.9 ↘		
	7: *10.5 ↑		
	8: 10.0 →		
	9: 8.7 ↑		
	10: 8.0 ↓		
Series	87.0	Series	47.0
Total	0.0	Total	0.0

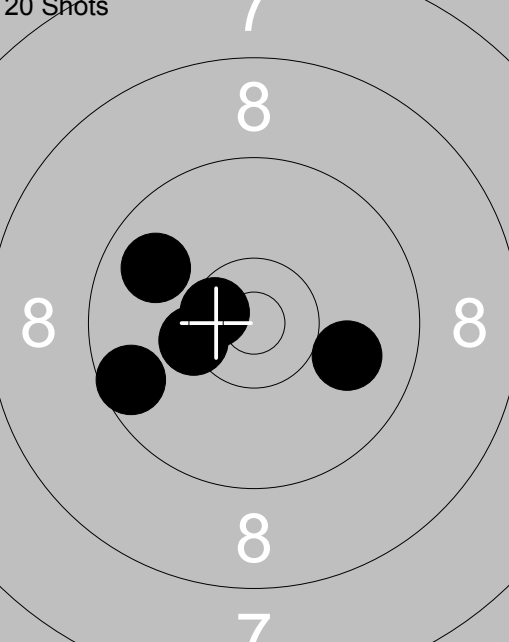
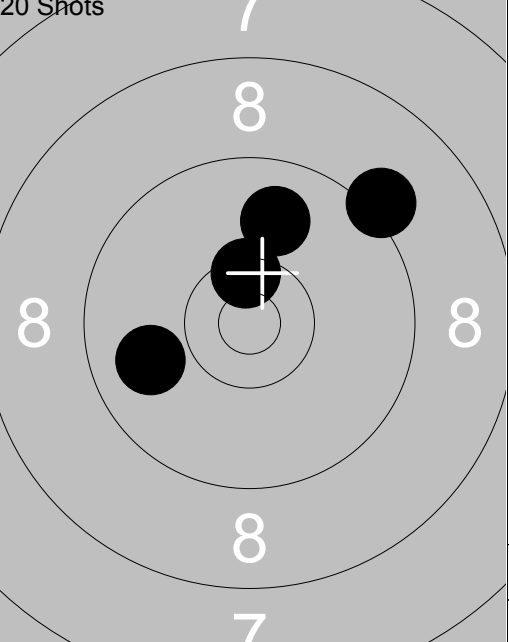
	1: *10.5 ↘		6: 9.2 ↗
	2: 9.6 ←		7: 0.0
	3: 9.8 ↖		8: *10.4 ↑
	4: *10.3 ↘		9: 9.9 ←
	5: 10.0 →		10: 9.9 ↑
Series	48.0	Series	37.0
Total	48.0	Total	85.0

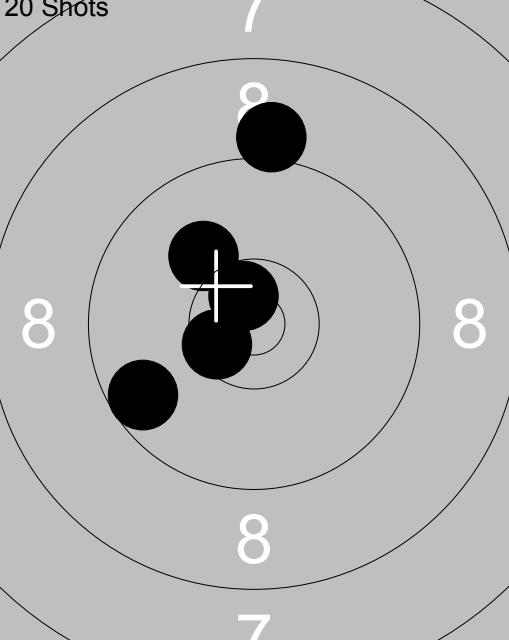
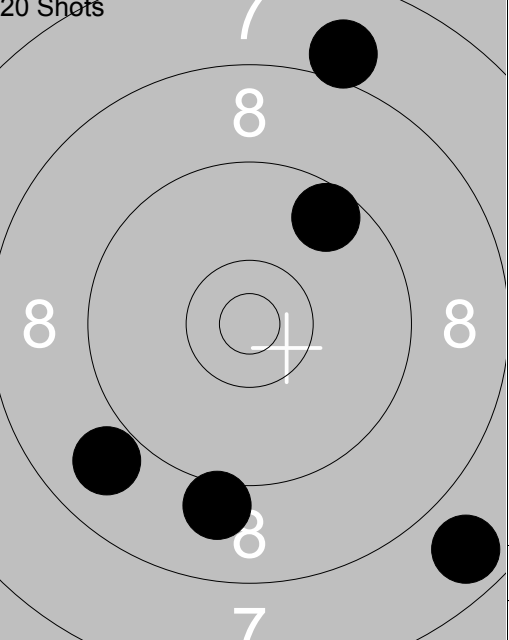
	11: *10.5 ↘		16: 8.0 ↑
	12: 9.6 ←		17: 8.9 ↖
	13: 10.1 ↖		18: 9.1 ↓
	14: 9.1 ↑		19: 7.8 ↘
	15: *10.6 ↘		20: 9.6 ↗
Series	48.0	Series	41.0
Total	133.0	Total	174.0

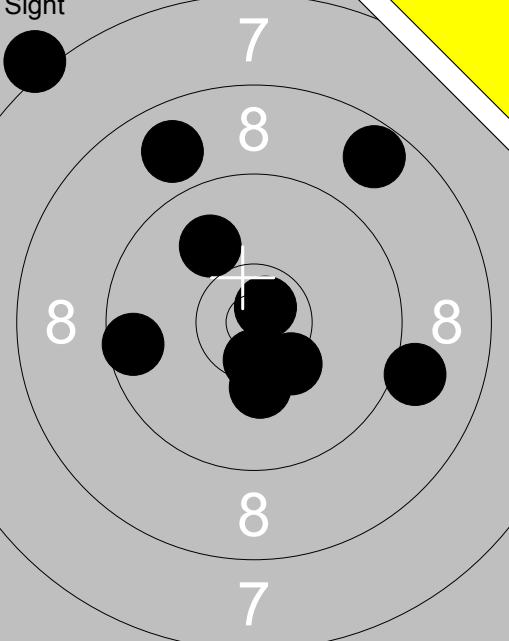
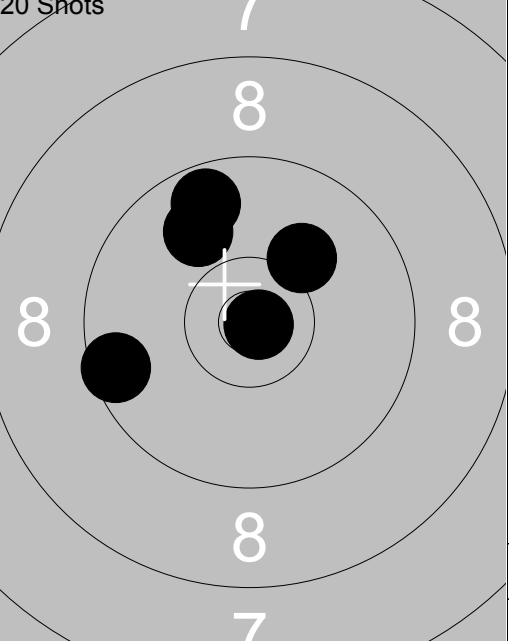

 <p>Sight</p>	<p>20 Shots</p> 	<p>1: 7.1 ↖</p> <p>2: 8.8 ↖</p> <p>3: 8.7 ↗</p> <p>4: 9.1 →</p> <p>5: 10.0 ↖</p> <p>6: 9.6 ←</p> <p>7: *10.7 ↗</p> <p>8: 10.2 ↓</p> <p>9: *10.5 ↓</p> <p>10: *10.3 ↘</p> <p>Series 91.0</p> <p>Total 0.0</p>	<p>1: 10.1 ↗</p> <p>2: 9.7 ↖</p> <p>3: 9.5 ←</p> <p>4: *10.9 →</p> <p>5: 9.9 ↖</p> <p>Series 47.0</p> <p>Total 47.0</p>
---	--	--	---

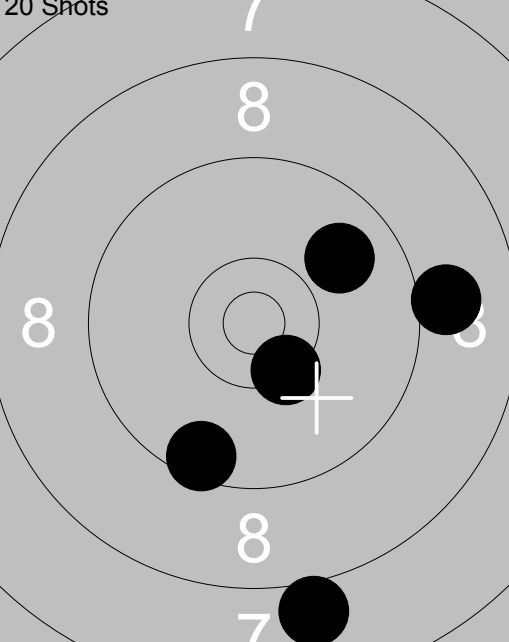
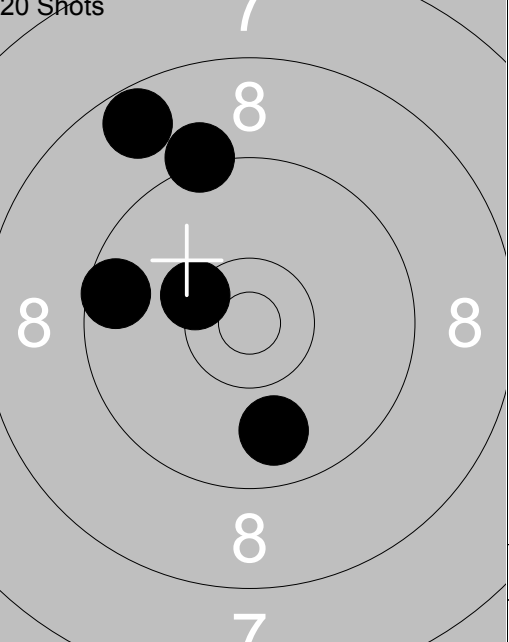
 <p>20 Shots</p>	<p>20 Shots</p> 	<p>6: *10.4 ↘</p> <p>7: 9.5 ↓</p> <p>8: 8.0 ↓</p> <p>9: 9.9 ↗</p> <p>10: 9.0 →</p> <p>Series 45.0</p> <p>Total 92.0</p>	<p>11: 8.7 ↖</p> <p>12: 9.2 ↖</p> <p>13: 9.9 ↓</p> <p>14: 9.6 ←</p> <p>15: *10.3 ↘</p> <p>Series 45.0</p> <p>Total 137.0</p>
---	---	---	--

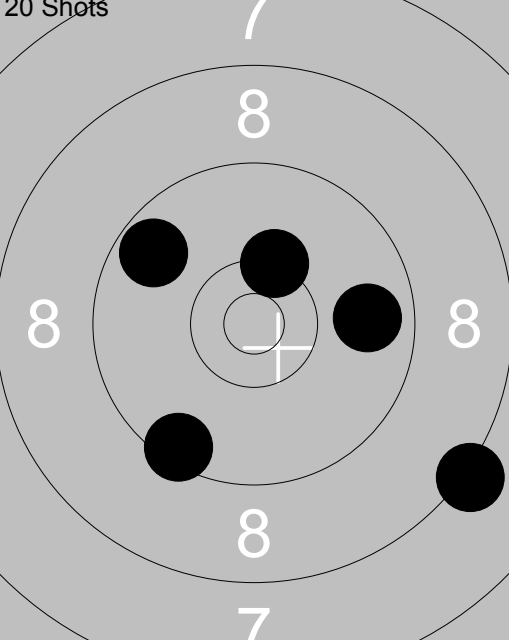
 <p>20 Shots</p>	<p>16: 9.8 →</p> <p>17: *10.3 ↗</p> <p>18: 9.5 ↓</p> <p>19: 9.7 ↖</p> <p>20: 8.2 ↘</p> <p>Series 45.0</p> <p>Total 182.0</p>		
--	--	--	--

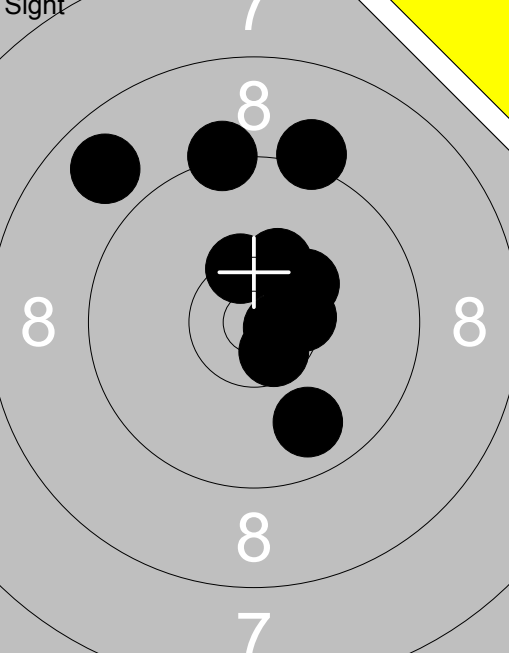
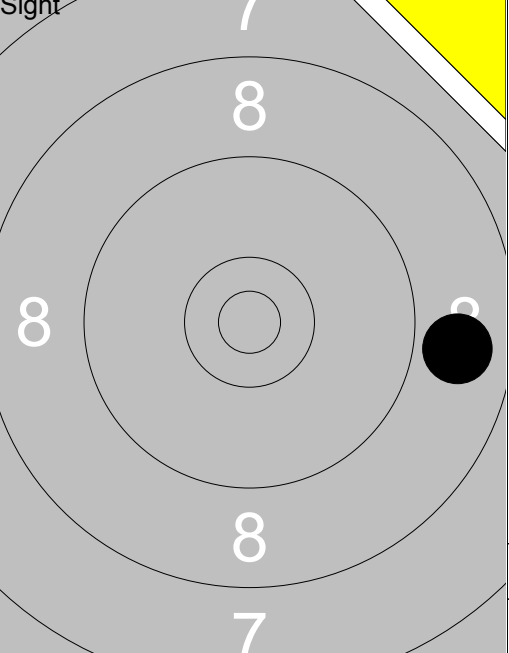
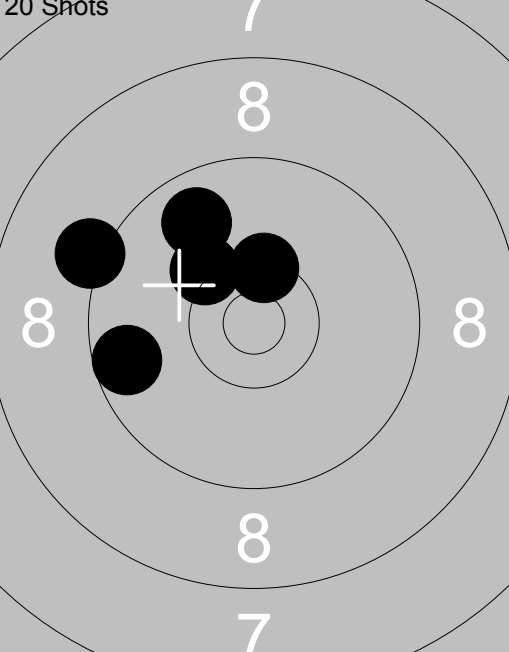
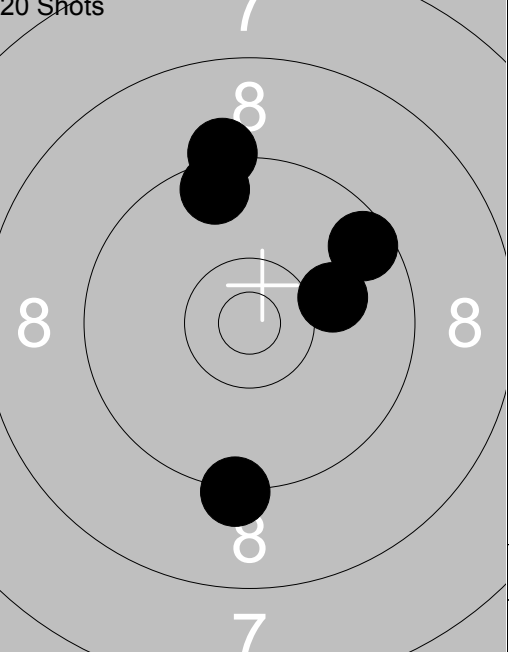
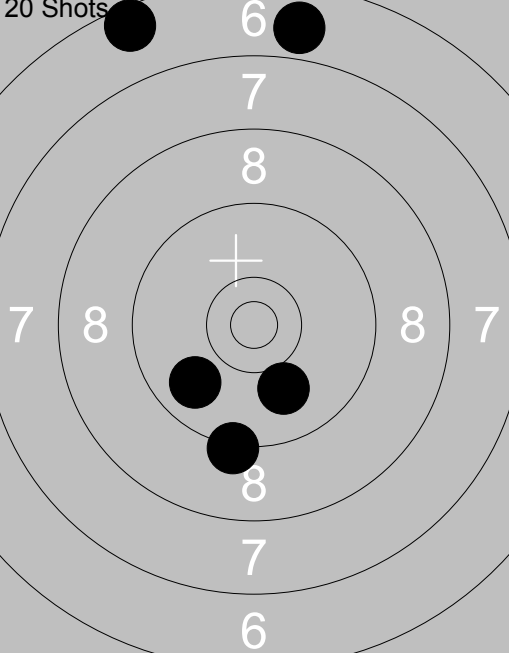
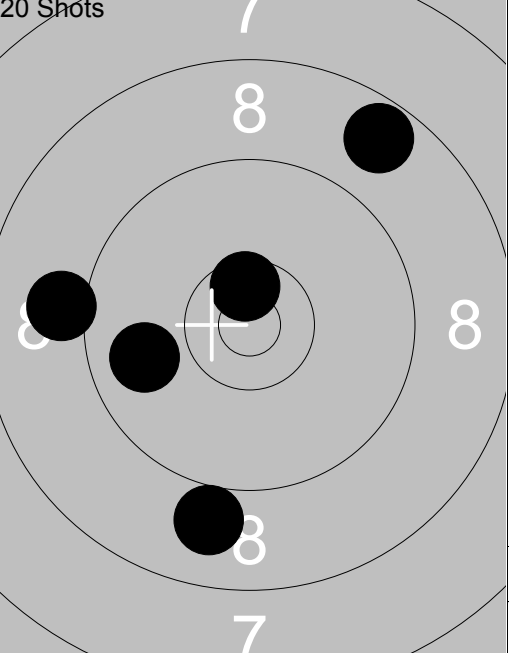
<p>Sight</p> 	<p>1: 9.2 ↗                  2: 9.3 ↑                  3: *10.4 ↗                  4: *10.7 →                  5: 9.8 ↘                  6: *10.3 ↗                  7: *10.3 ↗                  8: 8.8 ↗                  9: *10.6 ↘                  10: *10.5 →</p> <table border="1" style="width:100%; border-collapse: collapse;"> <tr><td>Series</td><td style="text-align:right;">95.0</td></tr> <tr><td>Total</td><td style="text-align:right;">0.0</td></tr> </table>	Series	95.0	Total	0.0	<p>Sight</p>  <p>11: 8.9 →</p> <table border="1" style="width:100%; border-collapse: collapse;"> <tr><td>Series</td><td style="text-align:right;">8.0</td></tr> <tr><td>Total</td><td style="text-align:right;">0.0</td></tr> </table>	Series	8.0	Total	0.0
Series	95.0									
Total	0.0									
Series	8.0									
Total	0.0									
<p>20 Shots</p> 	<p>1: 9.6 ←                  2: 9.8 ↗                  3: 10.2 ↘                  4: *10.4 ↗                  5: 9.2 ←</p> <table border="1" style="width:100%; border-collapse: collapse;"> <tr><td>Series</td><td style="text-align:right;">47.0</td></tr> <tr><td>Total</td><td style="text-align:right;">47.0</td></tr> </table>	Series	47.0	Total	47.0	<p>20 Shots</p>  <p>6: 9.6 ↗                  7: 10.1 →                  8: 9.6 ↑                  9: 9.2 ↑                  10: 9.3 ↓</p> <table border="1" style="width:100%; border-collapse: collapse;"> <tr><td>Series</td><td style="text-align:right;">46.0</td></tr> <tr><td>Total</td><td style="text-align:right;">93.0</td></tr> </table>	Series	46.0	Total	93.0
Series	47.0									
Total	47.0									
Series	46.0									
Total	93.0									
<p>20 Shots</p> 	<p>11: 9.8 ↘                  12: 10.0 ↘                  13: 9.3 ↘                  14: 6.9 ↑                  15: 6.6 ↗</p> <table border="1" style="width:100%; border-collapse: collapse;"> <tr><td>Series</td><td style="text-align:right;">40.0</td></tr> <tr><td>Total</td><td style="text-align:right;">133.0</td></tr> </table>	Series	40.0	Total	133.0	<p>20 Shots</p>  <p>16: 9.0 ↓                  17: 8.7 ↗                  18: 9.8 ←                  19: 9.1 ←                  20: *10.6 ↗</p> <table border="1" style="width:100%; border-collapse: collapse;"> <tr><td>Series</td><td style="text-align:right;">45.0</td></tr> <tr><td>Total</td><td style="text-align:right;">178.0</td></tr> </table>	Series	45.0	Total	178.0
Series	40.0									
Total	133.0									
Series	45.0									
Total	178.0									

	<p>1: 9.1 ↙ 2: 10.3 ↓ 3: *10.4 ↙ 4: 8.2 ↖ 5: 9.7 ↑ 6: 7.3 ← 7: 8.5 ← 8: 9.8 ← 9: 10.0 ← 10: 10.3 ↖</p> <table border="1" style="width:100%; border-collapse: collapse;"> <tr><td>Series</td><td>90.0</td></tr> <tr><td>Total</td><td>0.0</td></tr> </table>	Series	90.0	Total	0.0		<p>11: 10.1 ↓ 12: 9.4 → 13: *10.7 → 14: 10.2 →</p> <table border="1" style="width:100%; border-collapse: collapse;"> <tr><td>Series</td><td>39.0</td></tr> <tr><td>Total</td><td>0.0</td></tr> </table>	Series	39.0	Total	0.0
Series	90.0										
Total	0.0										
Series	39.0										
Total	0.0										

	<p>1: 9.5 ↑ 2: 10.2 ↑ 3: *10.5 ↓ 4: 9.8 ↗ 5: 10.0 ↖</p> <table border="1" style="width:100%; border-collapse: collapse;"> <tr><td>Series</td><td>48.0</td></tr> <tr><td>Total</td><td>48.0</td></tr> </table>	Series	48.0	Total	48.0		<p>6: 10.1 ← 7: 9.4 ↙ 8: 10.0 → 9: 10.1 ← 10: 9.9 ↓</p> <table border="1" style="width:100%; border-collapse: collapse;"> <tr><td>Series</td><td>48.0</td></tr> <tr><td>Total</td><td>96.0</td></tr> </table>	Series	48.0	Total	96.0
Series	48.0										
Total	48.0										
Series	48.0										
Total	96.0										

	<p>11: *10.6 ↗ 12: *10.4 ↙ 13: *10.4 ↓ 14: 10.0 ↗ 15: 10.1 ↓</p> <table border="1" style="width:100%; border-collapse: collapse;"> <tr><td>Series</td><td>50.0</td></tr> <tr><td>Total</td><td>146.0</td></tr> </table>	Series	50.0	Total	146.0		<p>16: 10.2 ↖ 17: *10.4 ↗ 18: 10.2 → 19: *10.4 → 20: *10.6 ↙</p> <table border="1" style="width:100%; border-collapse: collapse;"> <tr><td>Series</td><td>50.0</td></tr> <tr><td>Total</td><td>196.0</td></tr> </table>	Series	50.0	Total	196.0
Series	50.0										
Total	146.0										
Series	50.0										
Total	196.0										

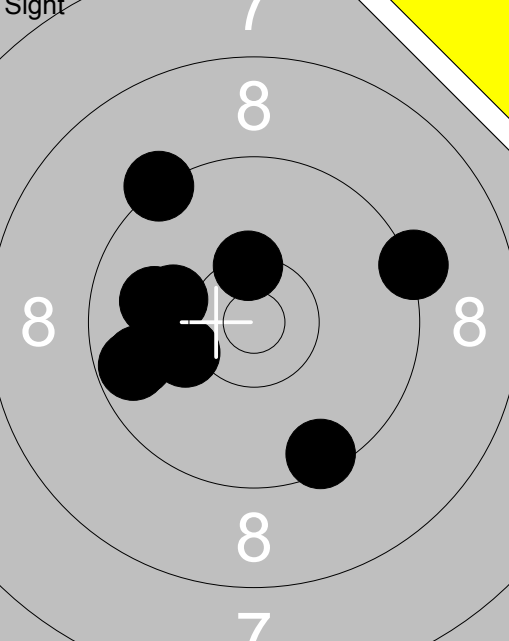
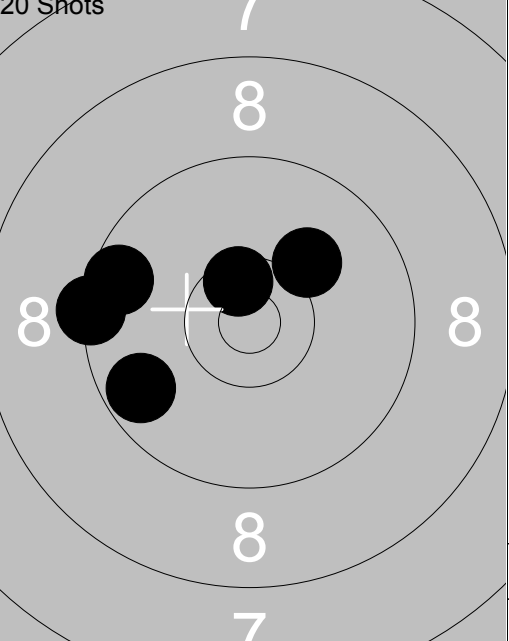
<p>Sight</p> 	<p>1: 9.3 →</p> <p>2: 9.5 ↓</p> <p>3: 10.1 ←</p> <p>4: 9.7 ←</p> <p>5: 9.3 ↗</p> <p>6: 9.7 ←</p> <p>7: *10.4 ↗</p> <p>8: 9.9 ←</p> <p>9: 10.2 ↙</p>	<p>20 Shots</p> 	<p>1: 10.1 ↗</p> <p>2: *10.5 ↗</p> <p>3: 9.6 ←</p> <p>4: 9.7 ↙</p> <p>5: 9.4 ←</p>
Series 84.0		Series 47.0	
Total 0.0		Total 47.0	

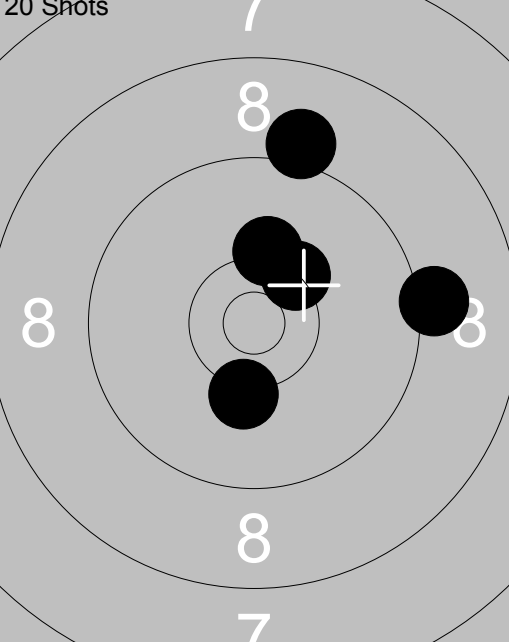
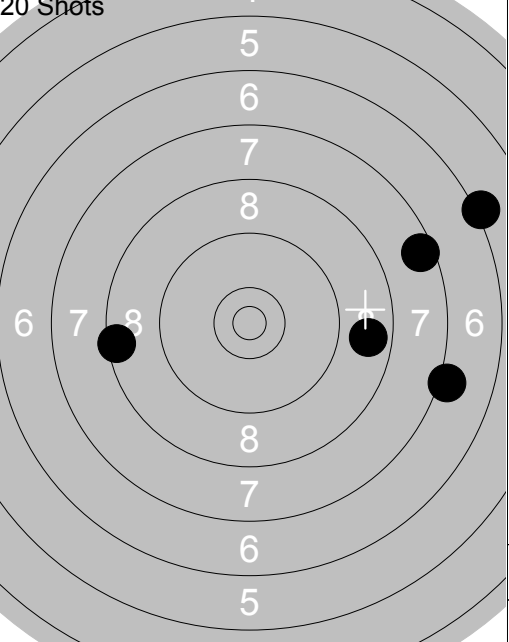
<p>20 Shots</p> 	<p>6: 10.2 ↑</p> <p>7: 10.2 ↓</p> <p>8: 9.1 →</p> <p>9: *10.3 ↗</p> <p>10: 9.1 ↑</p>	<p>20 Shots</p> 	<p>11: 8.7 →</p> <p>12: 6.2 ↗</p> <p>13: 8.5 ←</p> <p>14: 7.6 ↗</p> <p>15: 7.2 →</p>
Series 48.0		Series 36.0	
Total 95.0		Total 131.0	

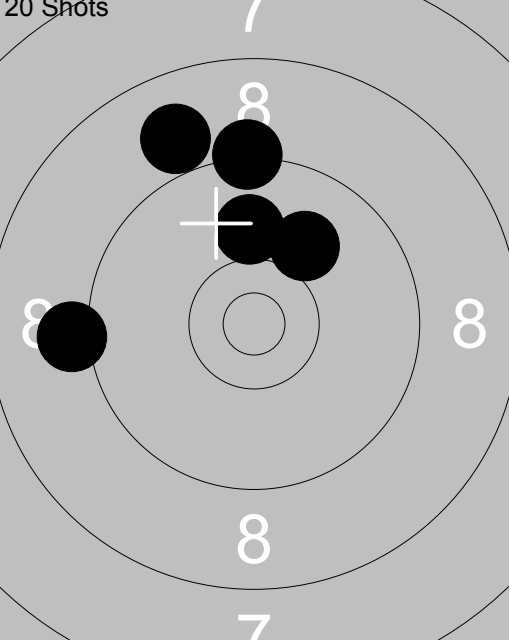
<p>20 Shots</p> 	<p>16: 10.0 ↗</p> <p>17: 8.9 ↗</p> <p>18: 9.1 ←</p> <p>19: 10.0 ↑</p> <p>20: 9.3 ↑</p>		
Series 46.0			
Total 177.0			

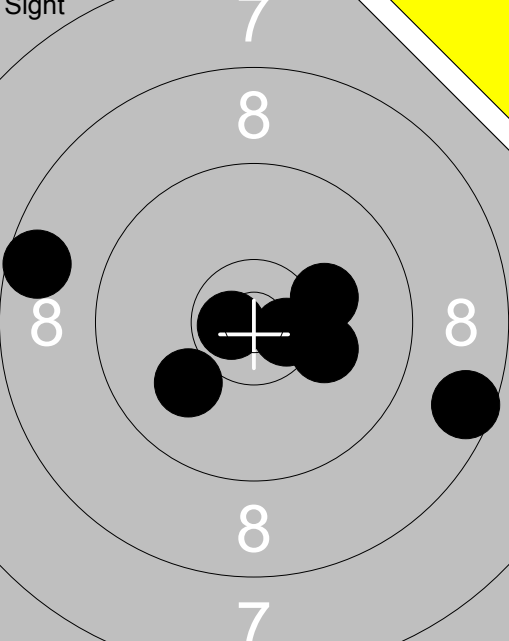
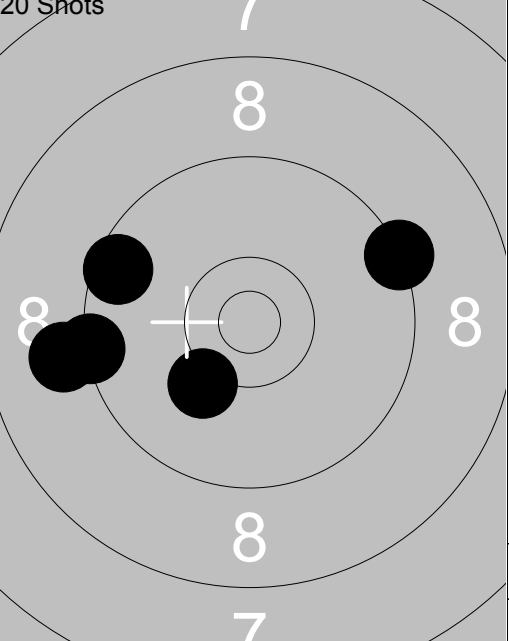
<p>Sight</p>  <p>Target diagram for Sight shot. Concentric circles labeled 7, 8, 8, 7. A yellow triangle is in the top right corner. Five black dots are clustered in the center, with one dot in the 8 ring on the left and one in the 8 ring on the right.</p>	<p>1: 10.0 ↙ 2: 8.6 ← 3: *10.6 → 4: 8.6 → 5: 10.2 → 6: 10.2 → 7: *10.7 ↙</p>	<p>20 Shots</p>  <p>Target diagram for 20 Shots. Concentric circles labeled 7, 8, 8, 7. Five black dots are scattered: one in the 8 ring on the left, one in the 8 ring on the right, and three in the 7 ring.</p>	<p>1: 10.2 ↙ 2: 9.3 ← 3: 9.5 ↙ 4: 9.1 ← 5: 9.3 →</p>
Series 66.0		Series 46.0	
Total 0.0		Total 46.0	

<p>20 Shots</p>  <p>Target diagram for 20 Shots. Concentric circles labeled 7, 8, 8, 7. Five black dots are clustered in the center, with one dot in the 8 ring on the left and one in the 8 ring on the right.</p>	<p>6: 9.9 ↑ 7: 10.2 → 8: 10.1 ↗ 9: 9.1 → 10: 9.8 →</p>	<p>20 Shots</p>  <p>Target diagram for 20 Shots. Concentric circles labeled 7, 8, 8, 7. Five black dots are scattered: one in the 8 ring on the left, one in the 8 ring on the right, and three in the 7 ring.</p>	<p>11: *10.5 ↘ 12: 7.6 ↗ 13: 6.8 ↘ 14: 8.8 ← 15: 9.9 ↘</p>
Series 47.0		Series 40.0	
Total 93.0		Total 133.0	

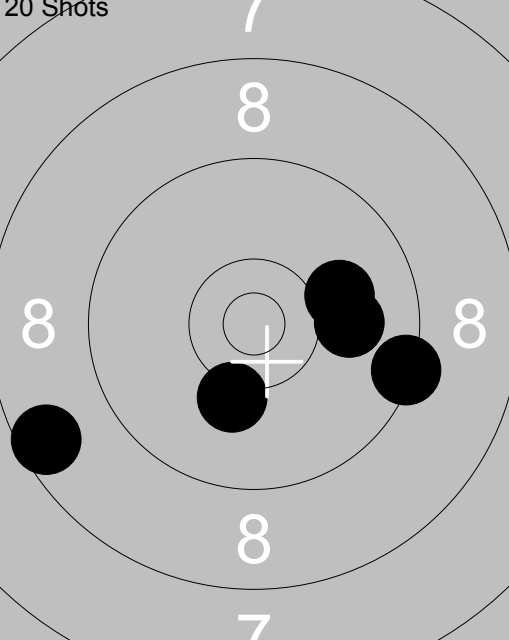
<p>20 Shots</p>  <p>Target diagram for 20 Shots. Concentric circles labeled 7, 8, 8, 7. Five black dots are clustered in the center, with one dot in the 8 ring on the left and one in the 8 ring on the right.</p>	<p>16: 9.4 → 17: 10.1 → 18: 10.0 → 19: 8.6 ← 20: 10.2 ↓</p>		
Series 47.0			
Total 180.0			

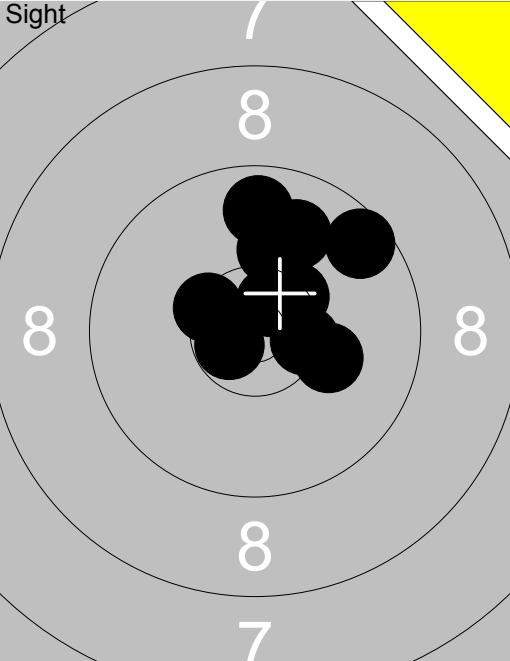
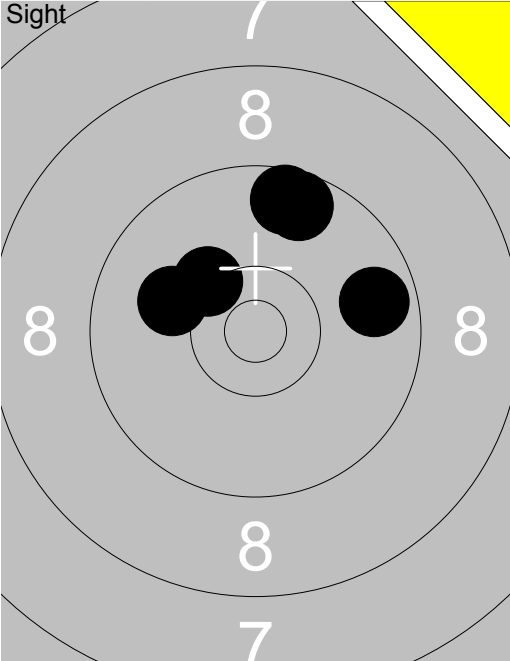
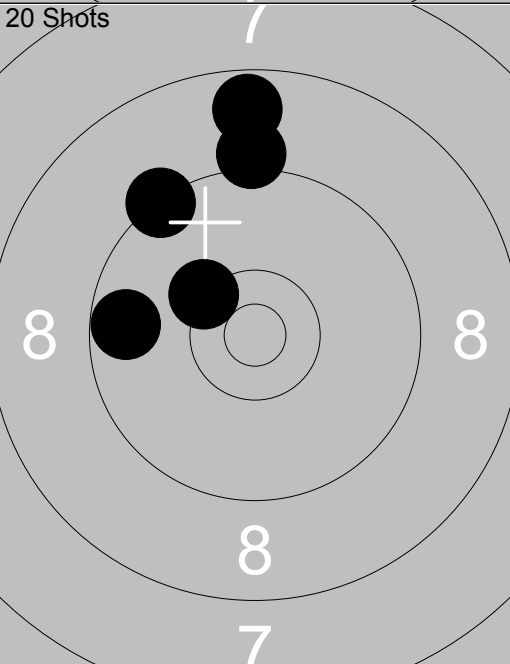
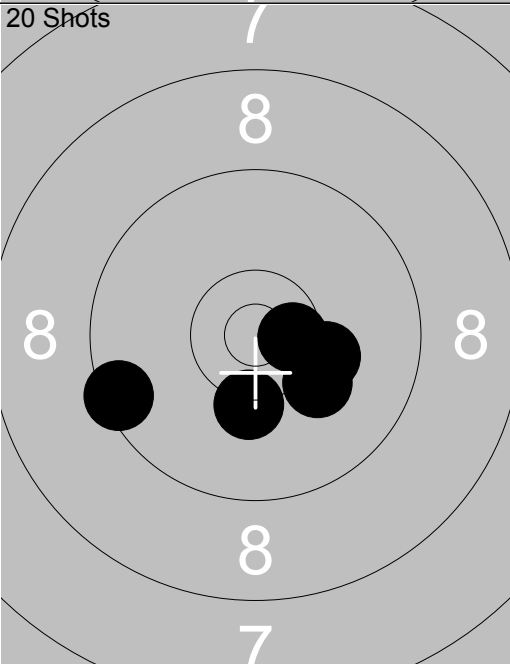
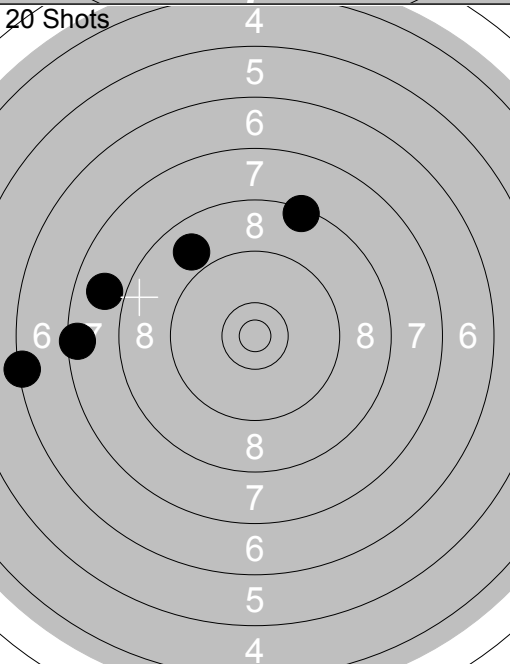
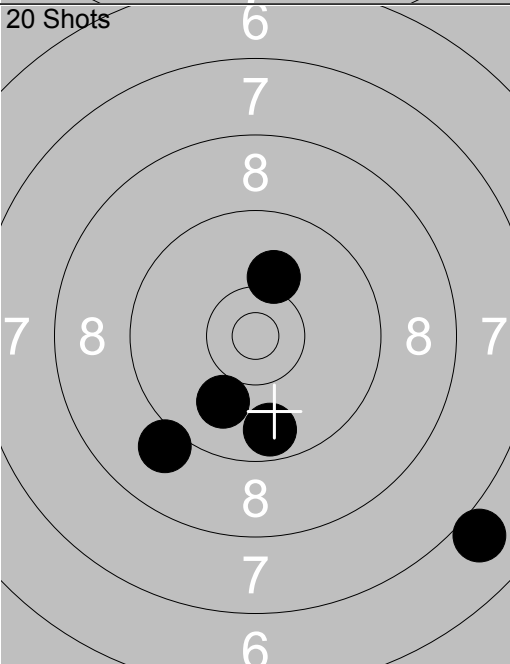
Relay	Lane	Marlene Forsell			
4	3				
50m	Ramselefors	Sen-S	Vb		
08.07.2014	Tavelträffen Korthäll 2014	Ramselefors SKF			
Sight		1: *10.4 ↗ 2: 9.9 ↑ 3: *10.4 → 4: 9.6 ↗ 5: 10.2 → 6: *10.7 ↘ 7: 9.7 ↑ 8: *10.4 ↖ 9: *10.6 ↗ 10: 10.1 ↑ Series 97.0 Total 0.0	Sight		11: 10.3 ↖ 12: 9.6 ↑ 13: 9.7 → 14: 9.6 ↑ 15: 10.1 ↖ Series 47.0 Total 0.0
20 Shots		1: *10.3 ↖ 2: 9.1 ↑ 3: 9.3 ↖ 4: 9.7 ← 5: 8.7 ↑ Series 45.0 Total 45.0	20 Shots		6: 9.5 ↖ 7: *10.6 → 8: 10.2 → 9: 10.3 ↓ 10: 10.2 ↘ Series 49.0 Total 94.0
20 Shots		11: 8.9 ↖ 12: 7.5 ← 13: 7.9 ← 14: 8.4 ↑ 15: 6.4 ← Series 36.0 Total 130.0	20 Shots		16: 7.0 ↘ 17: 9.1 ↖ 18: 10.0 ↓ 19: 9.7 ↓ 20: 10.1 ↑ Series 45.0 Total 175.0

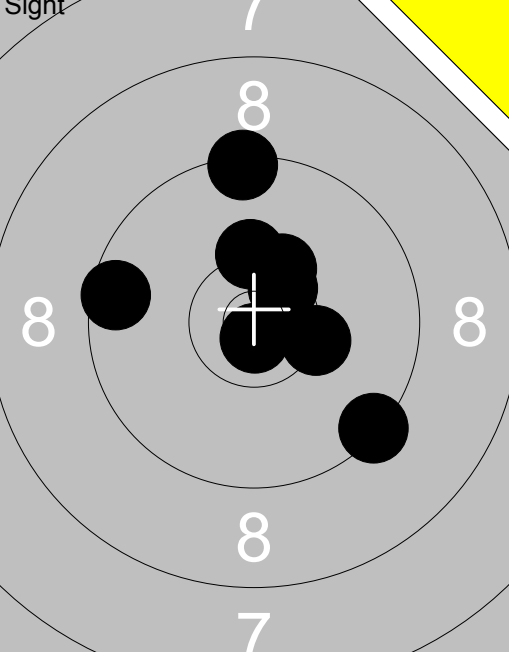
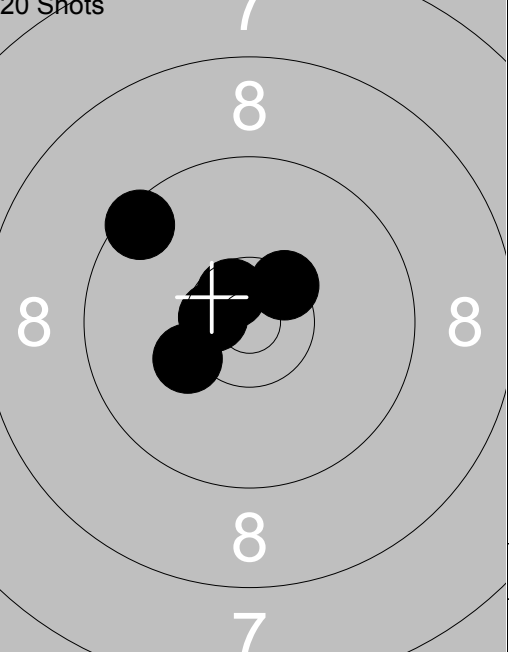
<p>Sight</p> 	<p>1: *10.5 ↗</p> <p>2: 9.4 ↘</p> <p>3: *10.3 →</p> <p>4: *10.3 ↗</p> <p>5: *10.8 ↓</p> <p>6: 10.3 ↑</p> <p>7: 9.4 ↑</p> <p>8: 9.5 ←</p>	<p>20 Shots</p> 	<p>1: *10.6 ↖</p> <p>2: *10.4 ↗</p> <p>3: 10.2 ↙</p> <p>4: *10.6 ↖</p> <p>5: 9.5 ↖</p>
Series 77.0		Series 49.0	
Total 0.0		Total 49.0	

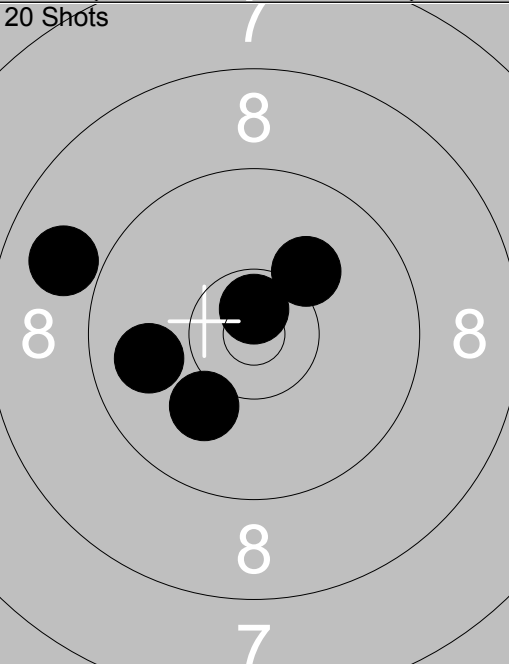
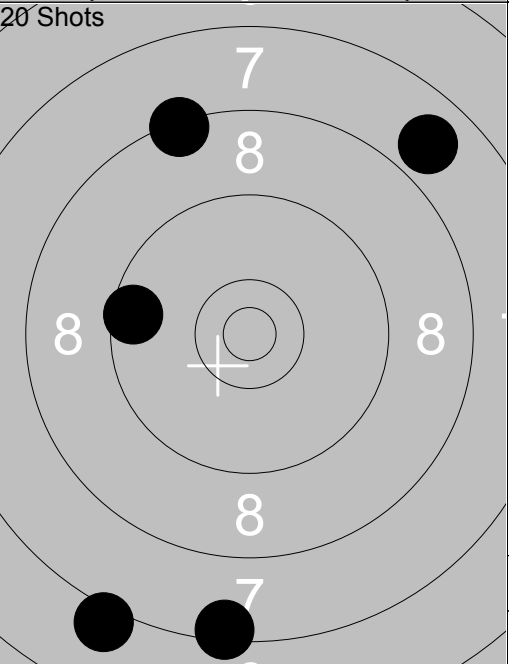
<p>20 Shots</p> 	<p>6: *10.7 ↑</p> <p>7: 10.1 ↗</p> <p>8: 8.9 ←</p> <p>9: 10.1 ↘</p> <p>10: 9.9 ←</p>	<p>20 Shots</p> 	<p>11: 7.1 ↘</p> <p>12: 7.4 ↓</p> <p>13: 7.9 ↗</p> <p>14: 9.6 ←</p> <p>15: 8.4 ↑</p>
Series 47.0		Series 38.0	
Total 96.0		Total 134.0	

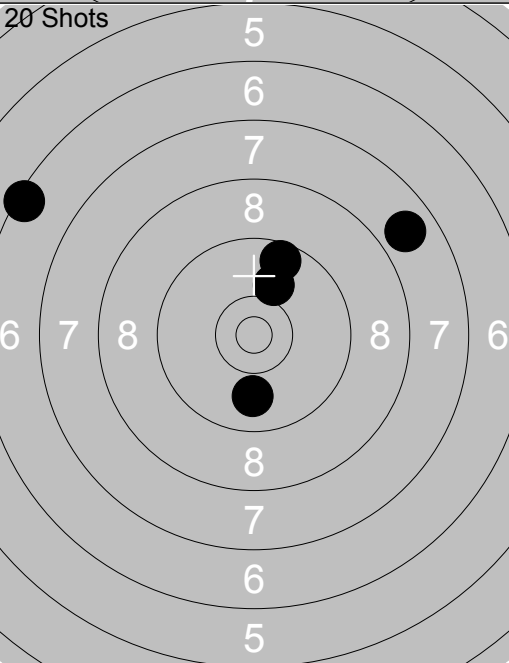
<p>20 Shots</p> 	<p>16: 10.0 ↑</p> <p>17: 9.9 ↓</p> <p>18: 7.8 ↗</p> <p>19: 6.4 ↖</p> <p>20: 9.6 ↑</p>		
Series 41.0			
Total 175.0			

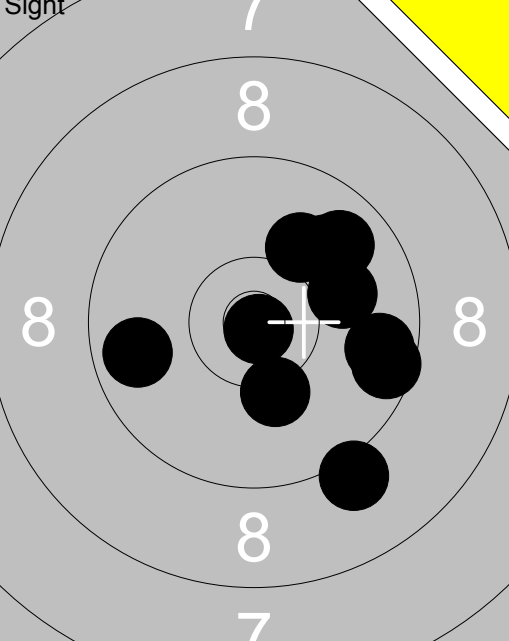
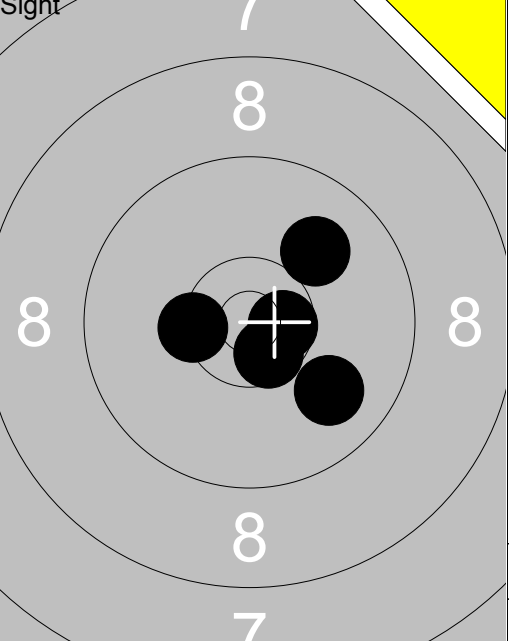
 <p style="font-size: 10pt;">Sight</p>	<p>1: 9.1 ↘</p> <p>2: *10.9 ↘</p> <p>3: 10.0 →</p> <p>4: 10.2 ↘</p> <p>5: 9.6 →</p> <p>6: 9.8 ←</p> <p>7: 9.7 →</p> <p>8: 10.1 ↗</p> <p>9: 9.9 ↗</p> <p>10: 9.8 ↗</p>	 <p style="font-size: 10pt;">Sight</p>	<p>11: 10.0 ↗</p> <p>12: *10.6 →</p> <p>13: 9.9 ↘</p> <p>14: *10.4 ←</p> <p>15: *10.6 ↘</p>
Series 94.0		Series 49.0	
Total 0.0		Total 0.0	

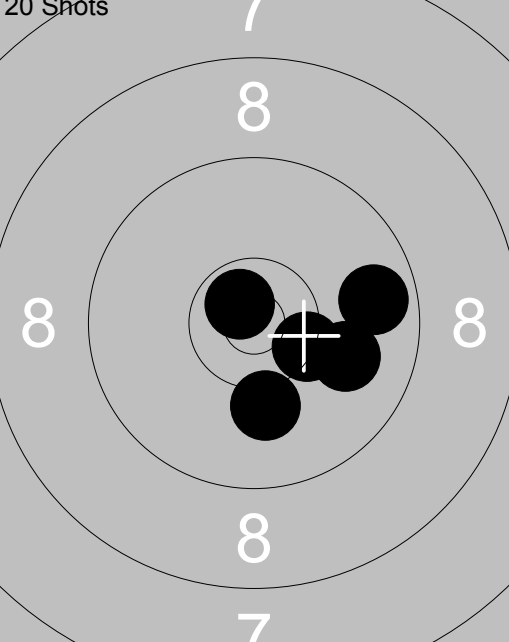
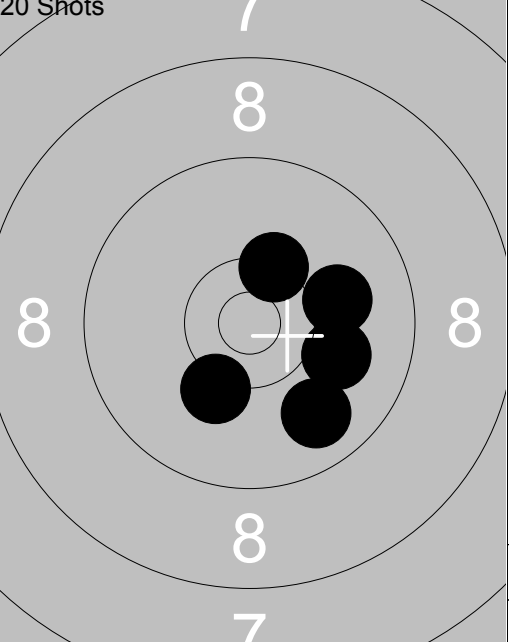
 <p style="font-size: 10pt;">20 Shots</p>	<p>1: 10.1 ↘</p> <p>2: 9.7 →</p> <p>3: *10.4 →</p> <p>4: 10.0 →</p> <p>5: *10.7 ↗</p>	 <p style="font-size: 10pt;">20 Shots</p>	<p>6: 10.2 ↘</p> <p>7: 9.8 ↘</p> <p>8: *10.3 ↗</p> <p>9: 10.0 →</p> <p>10: 10.0 →</p>
Series 49.0		Series 49.0	
Total 49.0		Total 98.0	

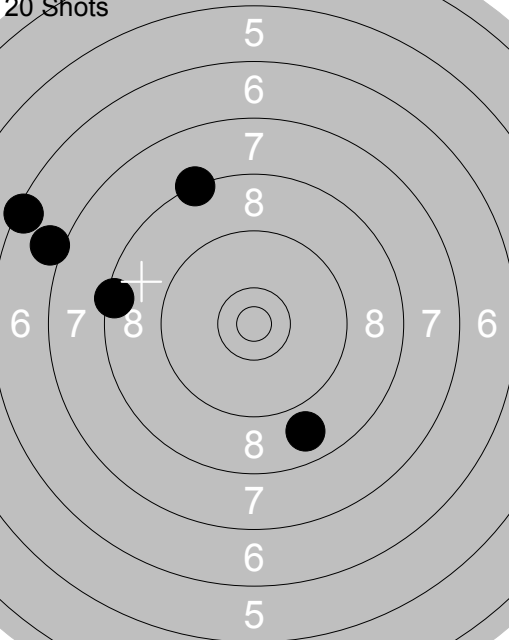
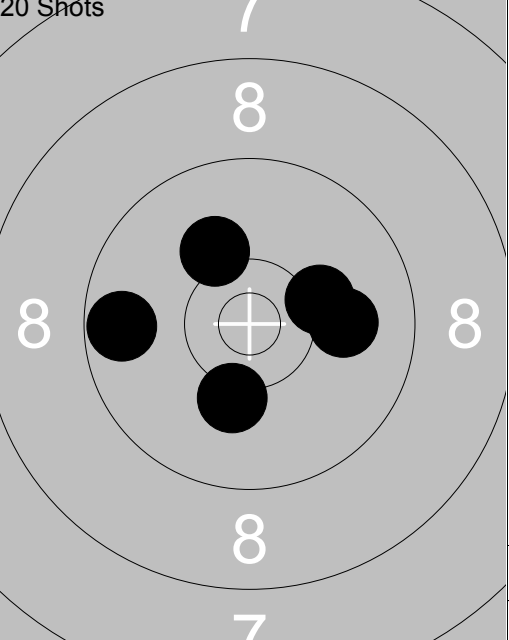
 <p style="font-size: 10pt;">20 Shots</p>	<p>11: 7.1 ←</p> <p>12: 6.4 ←</p> <p>13: 8.8 ↘</p> <p>14: 8.4 ←</p> <p>15: 8.3 ↗</p>	 <p style="font-size: 10pt;">20 Shots</p>	<p>16: 9.7 ←</p> <p>17: 10.1 ↗</p> <p>18: 10.0 →</p> <p>19: 10.2 →</p> <p>20: 10.2 ↘</p>
Series 37.0		Series 49.0	
Total 135.0		Total 184.0	



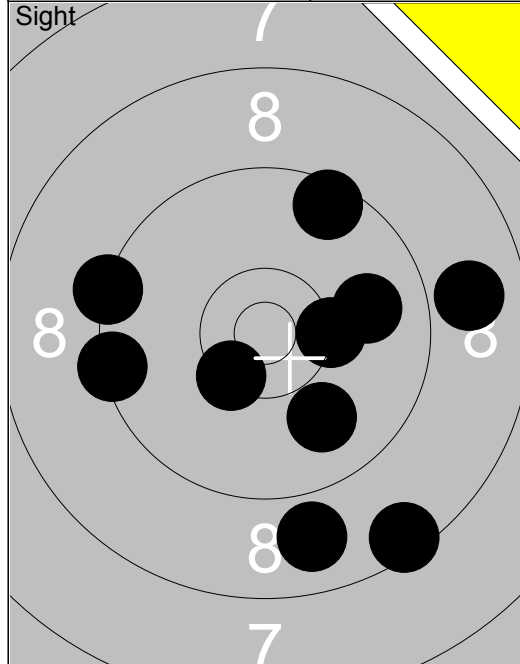

1:	8.5	↘
2:	9.9	↘
3:	8.9	↘
4:	9.5	↗
5:	9.9	→
6:	8.9	→
7:	*10.3	→
8:	*10.4	↙
9:	9.4	←
10:	9.3	←
Series	89.0	
Total	0.0	

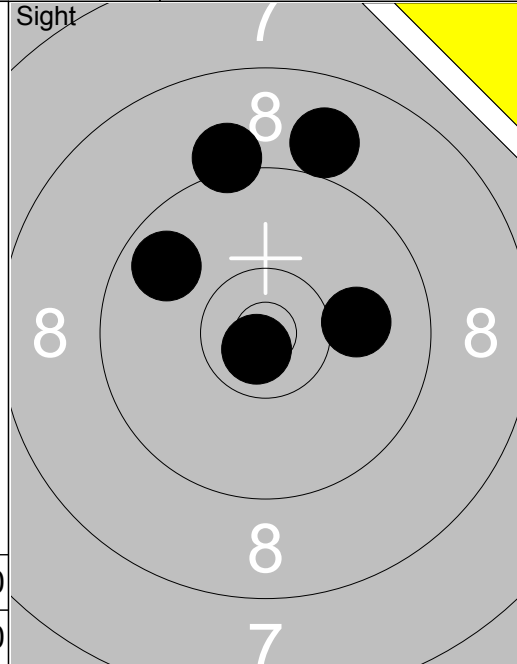

11:	9.8	↖
12:	*10.8	↙
13:	9.2	↗
14:	9.0	↗
15:	10.0	→
Series	47.0	
Total	0.0	

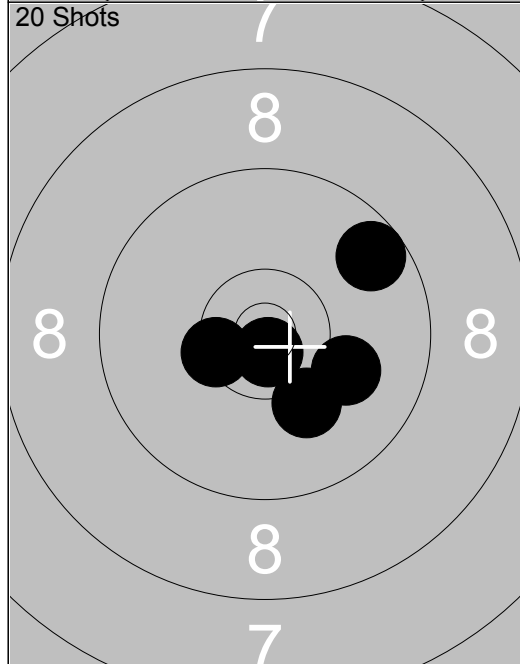

1:	9.6	↗
2:	10.1	→
3:	*10.4	↙
4:	10.2	↘
5:	*10.8	↘
Series	49.0	
Total	49.0	

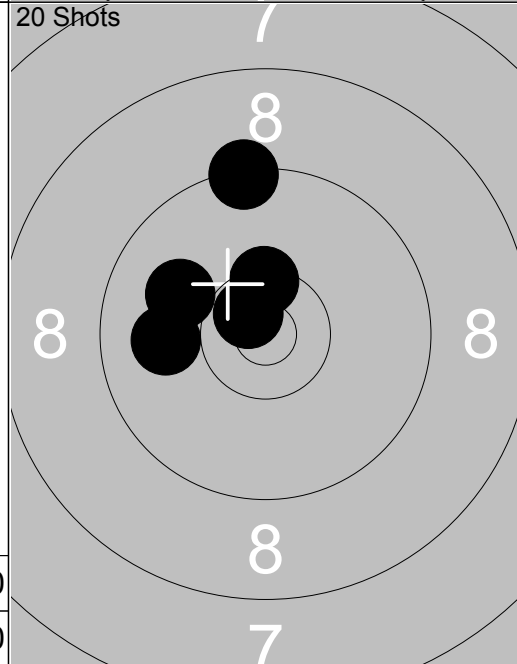

6:	*10.7	↖
7:	10.0	←
8:	10.0	↙
9:	9.3	↗
10:	*10.4	↗
Series	49.0	
Total	98.0	

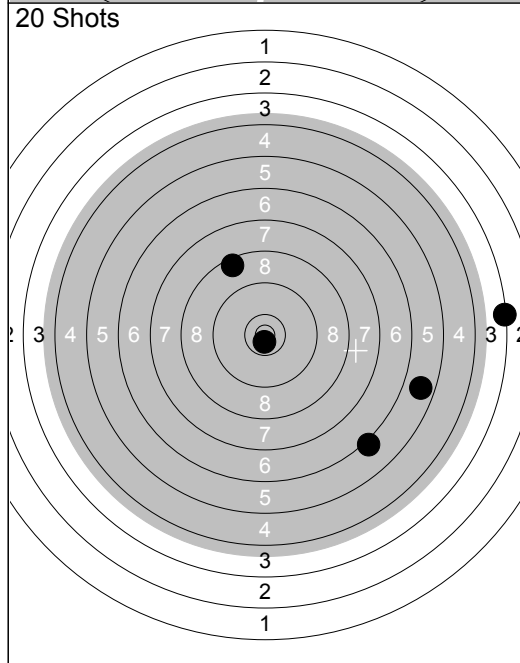

11:	6.2	↘
12:	5.7	→
13:	8.5	↗
14:	3.3	→
15:	*10.7	↘
Series	32.0	
Total	130.0	

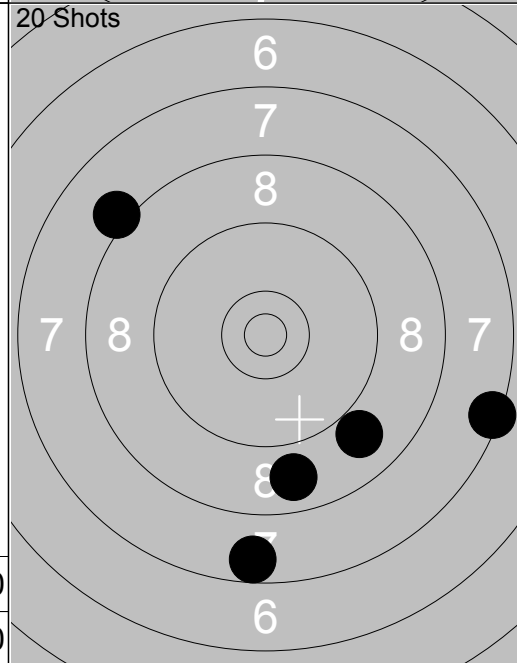

16:	8.1	↖
17:	8.8	↘
18:	8.9	↘
19:	7.4	→
20:	7.6	↘
Series	38.0	
Total	168.0	

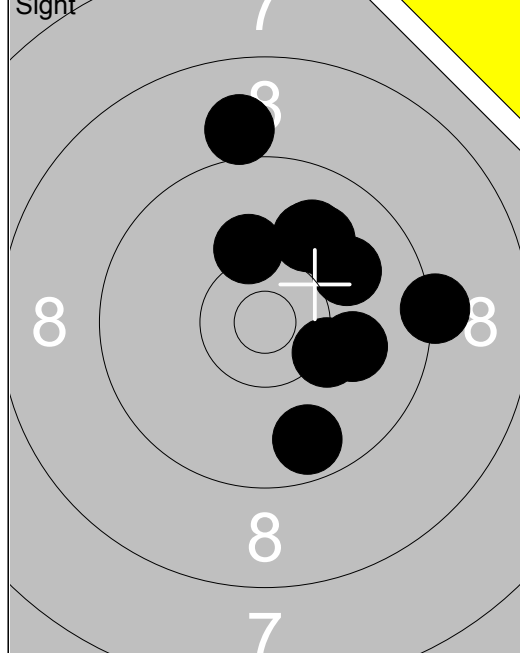

1:	9.7	↘
2:	9.0	↑
3:	10.3	↘
4:	10.2	↑
5:	10.0	↗
6:	9.2	→
7:	10.0	↑
8:	10.0	→
9:	10.0	↗
10:	10.0	↗
Series		97.0
Total		0.0

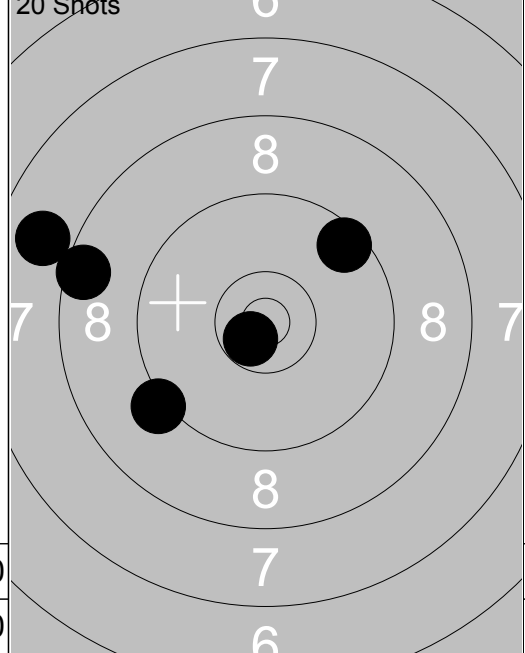

1:	9.5	↗
2:	7.9	↖
3:	*10.7	↘
4:	9.2	↘
5:	8.5	↖
Series		43.0
Total		43.0

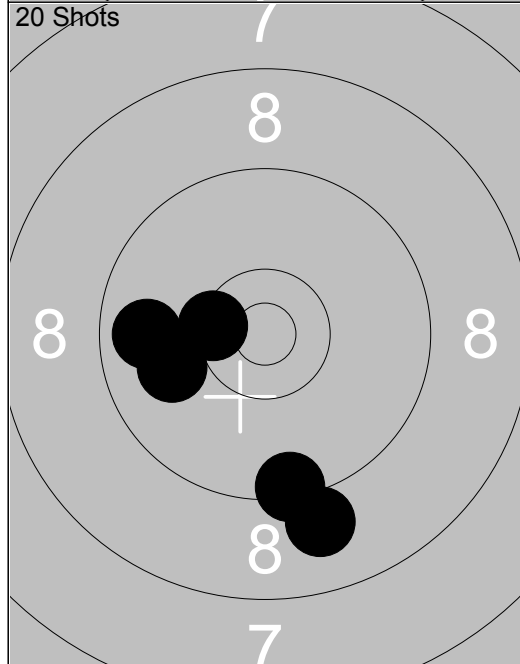

6:	*10.4	↖
7:	10.0	↖
8:	9.4	↓
9:	9.0	↓
10:	9.8	↖
Series		47.0
Total		90.0

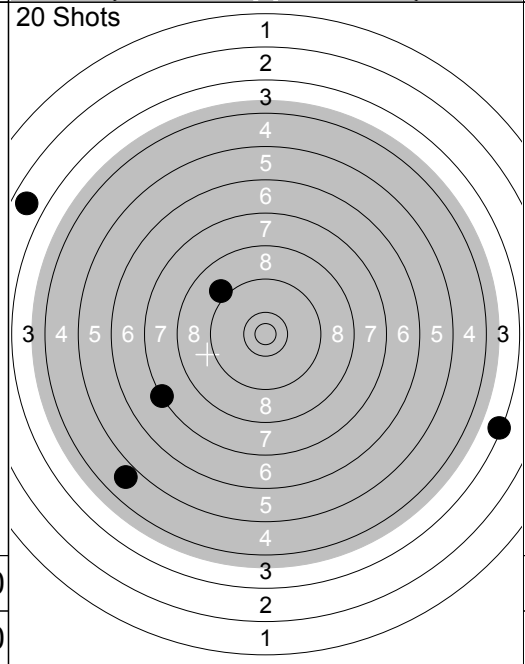

11:	9.1	↖
12:	7.3	↘
13:	3.4	→
14:	2.7	↖
15:	4.9	↘
Series		25.0
Total		115.0

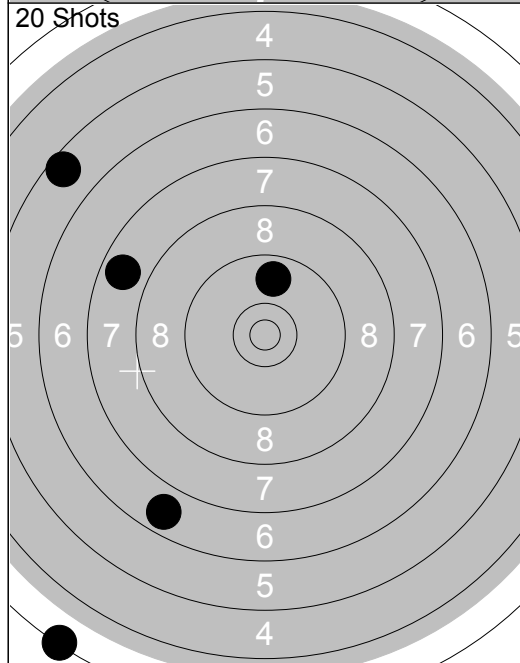

16:	5.6	↖
17:	9.8	↑
18:	3.3	↘
19:	7.8	↖
20:	6.8	↘
Series		30.0
Total		145.0

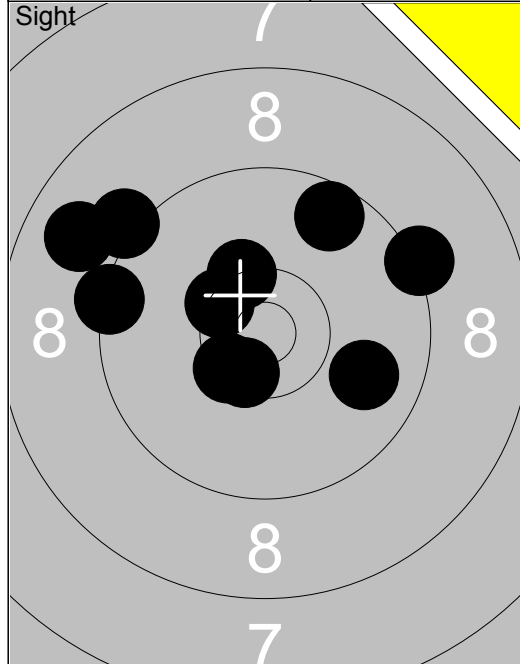

1:	9.6 ↗
2:	9.3 →
3:	*10.5 ↘
4:	9.9 →
5:	*10.3 ↗
6:	*10.4 ↘
7:	9.2 ↖
8:	*10.4 ↘
9:	9.4 ←
10:	8.9 ↖
<b>Series 93.0</b>	
<b>Total 0.0</b>	

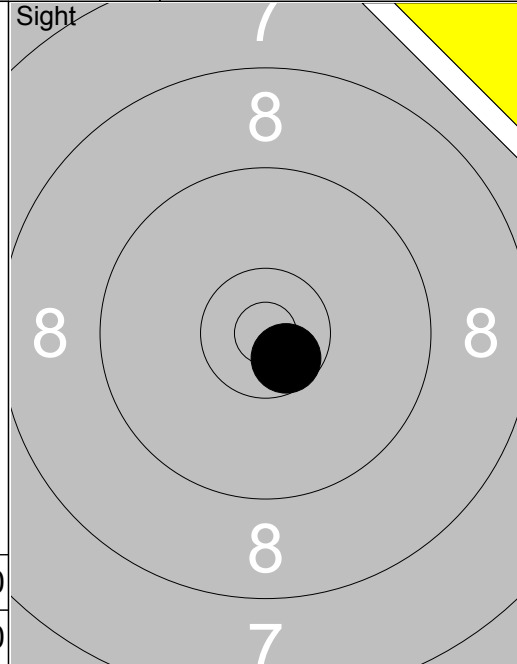

11:	*10.6 ↘
<b>Series 10.0</b>	
<b>Total 0.0</b>	

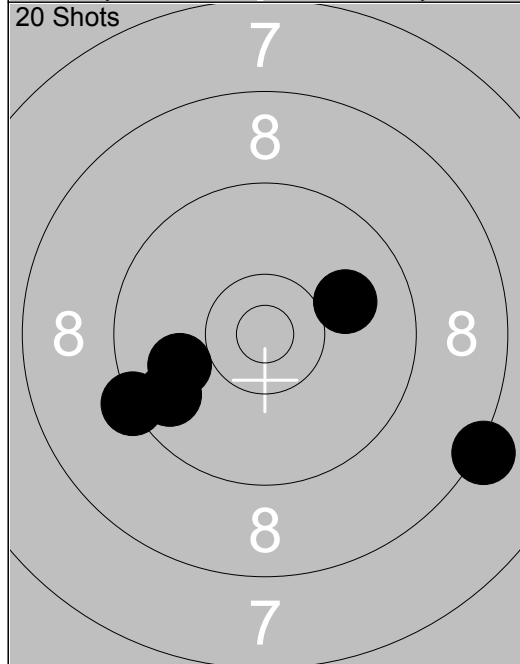

1:	10.0 ←
2:	9.7 ↖
3:	8.2 →
4:	10.0 →
5:	9.3 ↖
<b>Series 46.0</b>	
<b>Total 46.0</b>	

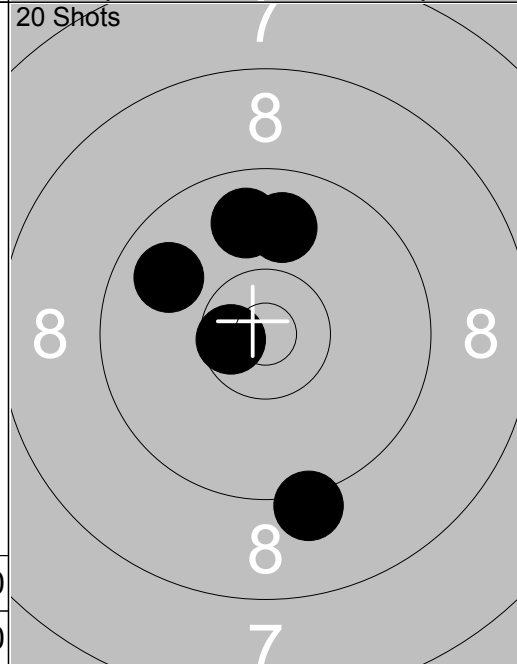

6:	9.8 ↖
7:	9.9 ↗
8:	*10.6 ↖
9:	9.2 ↘
10:	9.8 ↗
<b>Series 46.0</b>	
<b>Total 92.0</b>	

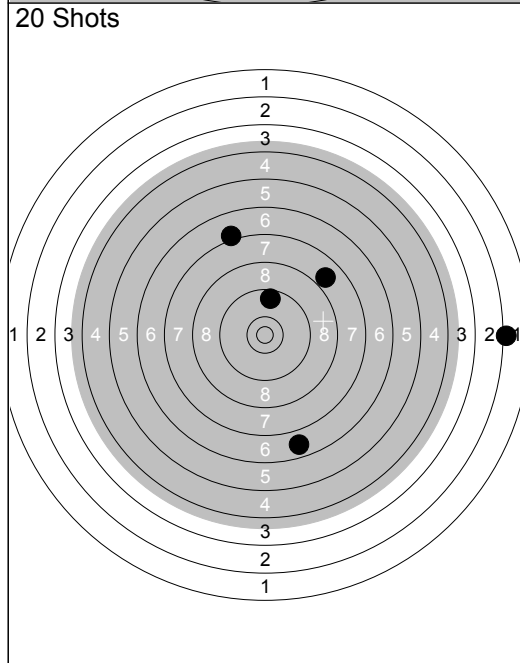

11:	2.2 →
12:	7.1 ↗
13:	7.9 ↗
14:	9.6 ↗
15:	6.8 ↘
<b>Series 31.0</b>	
<b>Total 123.0</b>	

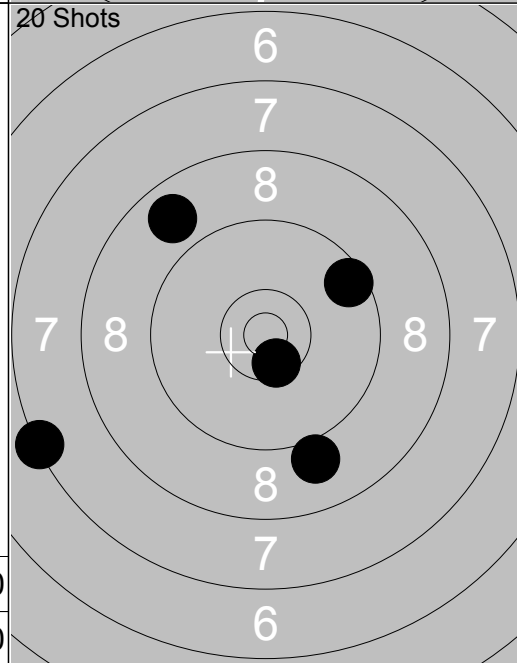

16:	8.8 ↖
17:	9.0 ↘
18:	7.3 ↖
19:	9.5 ↗
20:	*10.5 ↘
<b>Series 43.0</b>	
<b>Total 166.0</b>	

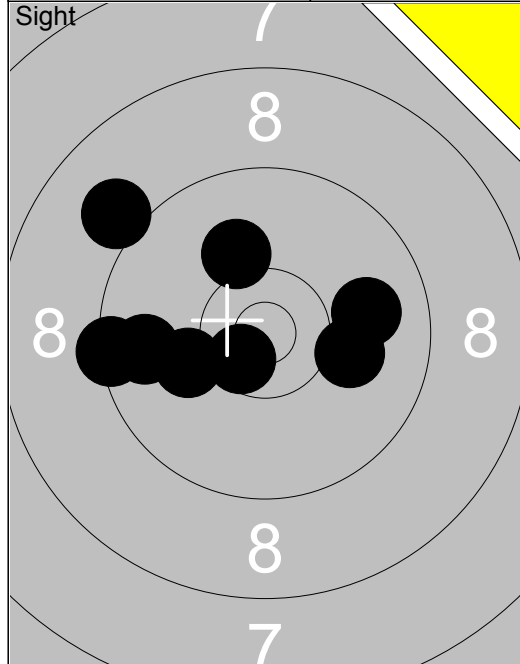

1: 10.1 ←
2: *10.6 ↘
3: 10.1 →
4: 9.7 ←
5: 9.0 ↗
6: 9.4 ←
7: 10.1 ↗
8: 9.9 →

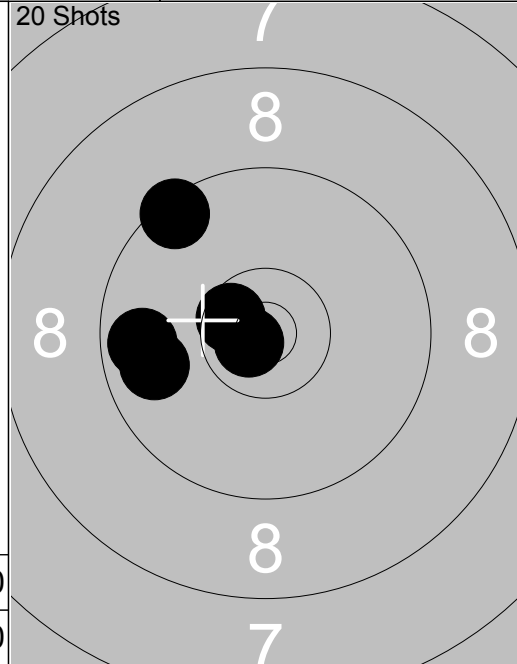

1: 9.8 ←
2: 9.7 ←
3: *10.8 ↘
4: 9.5 ↗
5: *10.6 ↘

Series 76.0
Total 0.0

Series 47.0
Total 47.0

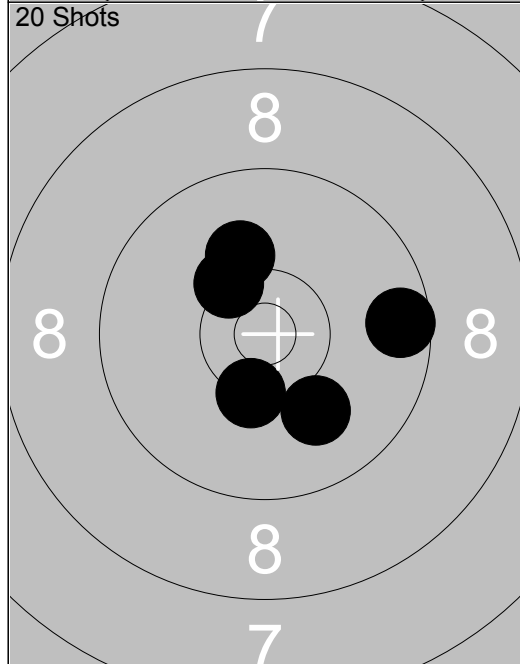

6: 9.6 →
7: *10.3 ↘
8: 10.1 ↗
9: 10.0 ↘
10: *10.3 ↘

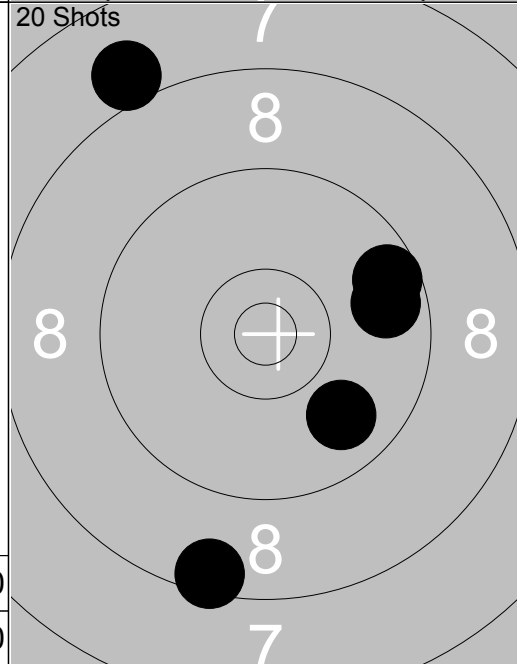

11: 8.0 ↗
12: 8.5 ↓
13: 9.7 →
14: 9.6 ↗
15: 9.8 ↘

Series 49.0
Total 96.0

Series 43.0
Total 139.0

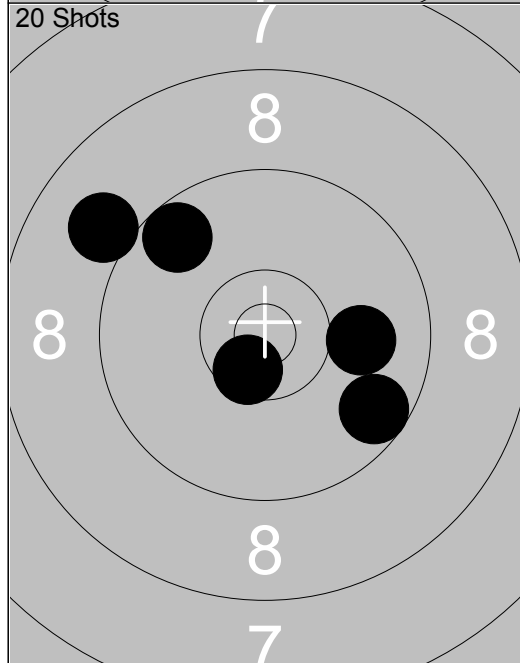

16: 9.6 ↘
17: 10.0 →
18: *10.6 ↘
19: 9.0 ↗
20: 9.6 ↗

Series 47.0
Total 186.0

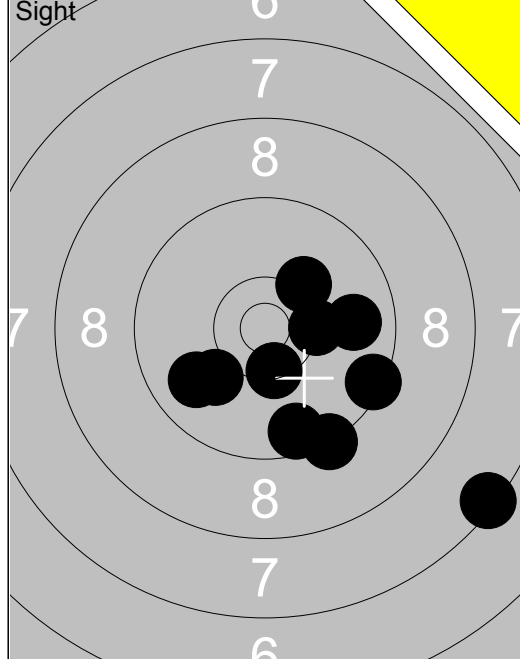

1: 7.4 ↘
2: *10.3 →
3: *10.4 ↓
4: 9.6 ↓
5: 9.3 ↓
6: 10.2 ↗
7: 9.9 ↙
8: 9.4 →
9: 10.1 ↙
10: 9.8 →
<b>Series 92.0</b>
<b>Total 0.0</b>

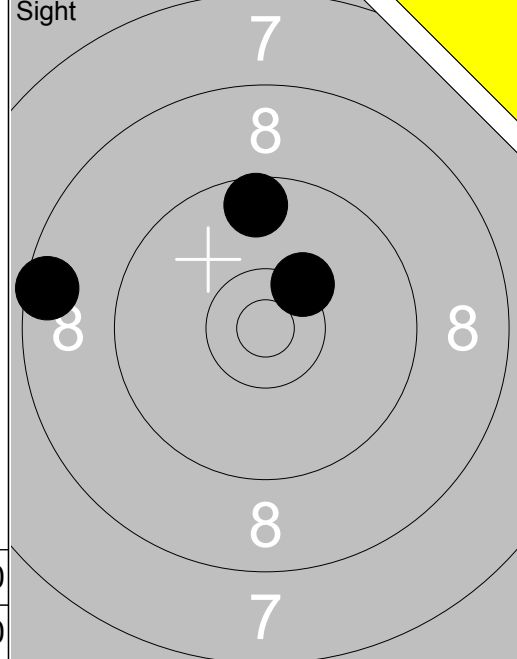

11: 8.5 ←
12: 9.6 ↑
13: *10.3 ↗
<b>Series 27.0</b>
<b>Total 0.0</b>

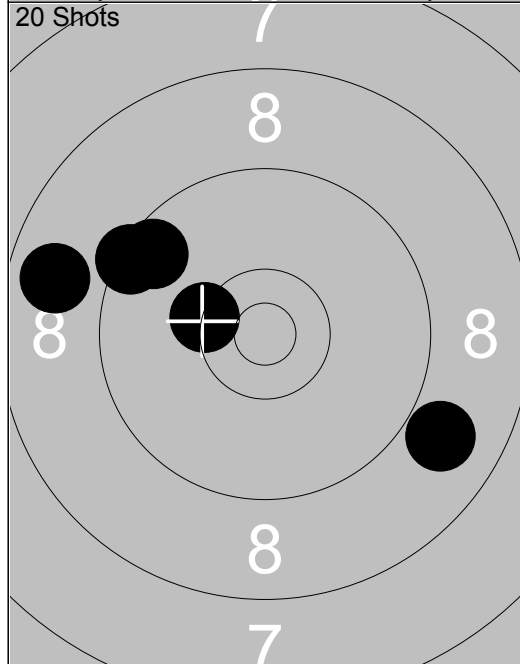

1: *10.3 ↙
2: 8.8 ←
3: 8.9 →
4: 9.4 ↗
5: 9.6 ↗
<b>Series 44.0</b>
<b>Total 44.0</b>

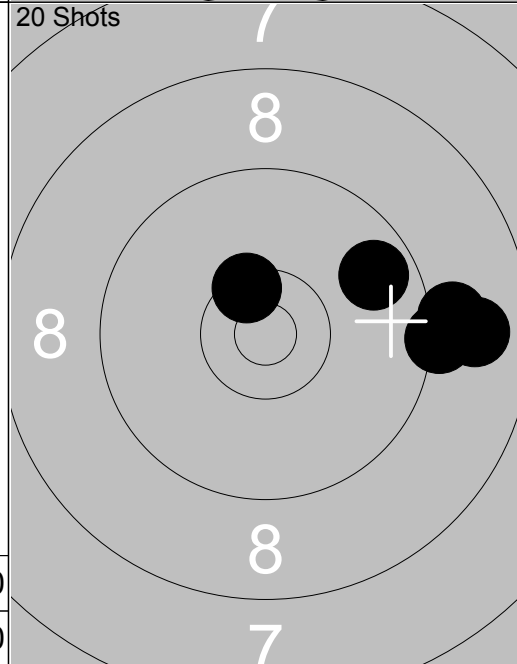

6: 9.1 →
7: *10.5 ↖
8: 8.9 →
9: 9.7 ↗
10: 9.2 →
<b>Series 45.0</b>
<b>Total 89.0</b>

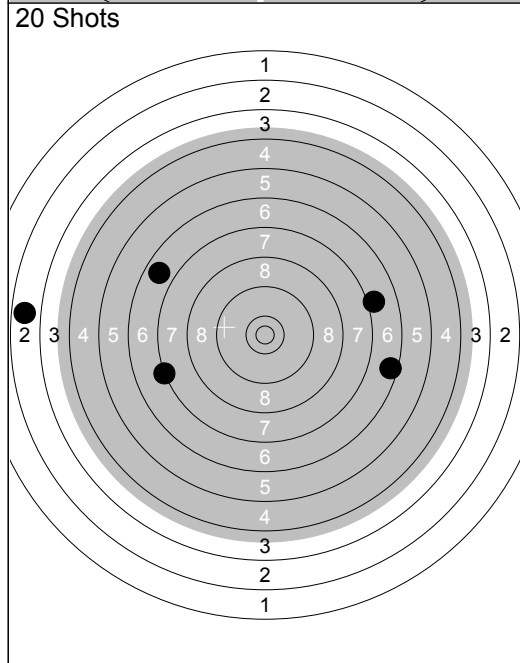

11: 6.8 ↙
12: 2.8 ←
13: 7.1 →
14: 6.5 →
15: 7.3 ↙
<b>Series 28.0</b>
<b>Total 117.0</b>

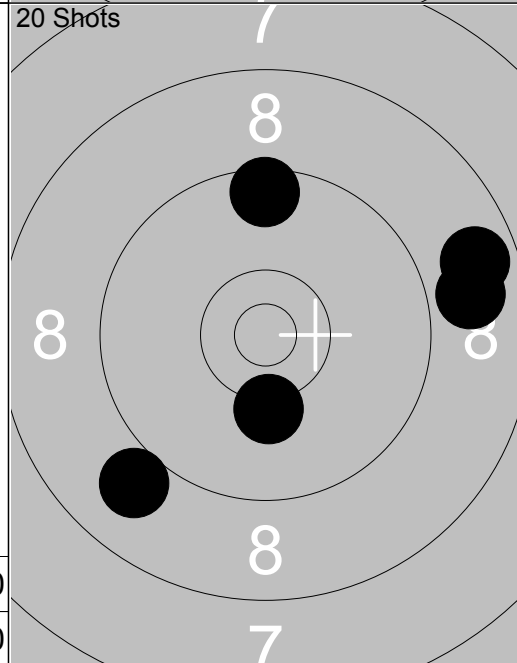

16: 10.2 ↓
17: 8.9 →
18: 8.7 →
19: 9.0 ↙
20: 9.5 ↑
<b>Series 44.0</b>
<b>Total 161.0</b>

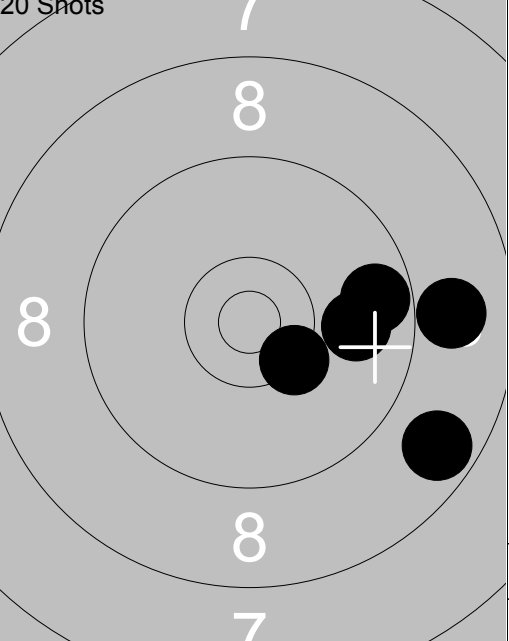
<p>Sight</p> 	<p>1: 8.0 ↘ 2: 9.6 → 3: 9.1 ↗ 4: 9.6 ↗ 5: *10.5 → 6: 8.6 → 7: *10.4 ← 8: *10.8 ↘ 9: 8.5 ↗ 10: 9.5 ↘</p> <p>Series 90.0 Total 0.0</p>	<p>20 Shots</p>  <p>1: 9.7 → 2: 9.9 → 3: 8.9 → 4: 8.7 ↘ 5: *10.4 ↘</p> <p>Series 44.0 Total 44.0</p>
---	--	--

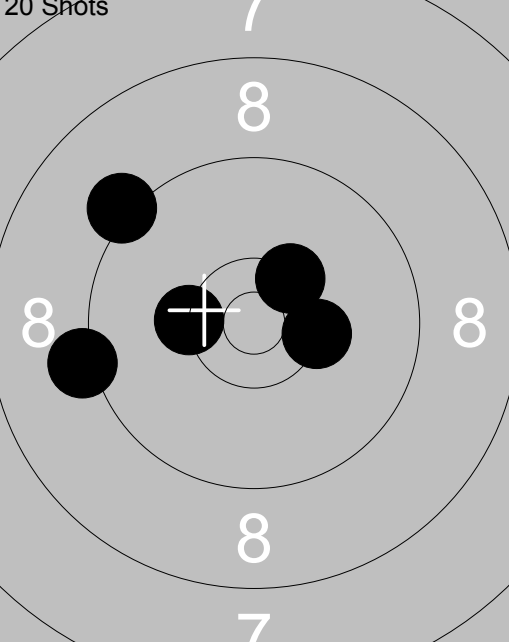
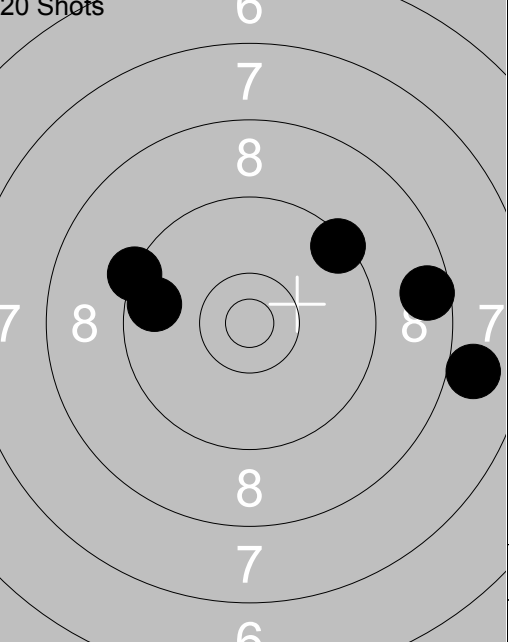
<p>20 Shots</p> 	<p>6: *10.3 → 7: *10.4 ↗ 8: 9.2 ↗ 9: *10.3 ← 10: 9.2 ←</p> <p>Series 48.0 Total 92.0</p>	<p>20 Shots</p>  <p>11: 9.3 ← 12: 9.7 ← 13: 8.0 → 14: 8.6 → 15: 9.4 ↗</p> <p>Series 43.0 Total 135.0</p>
---	--	---

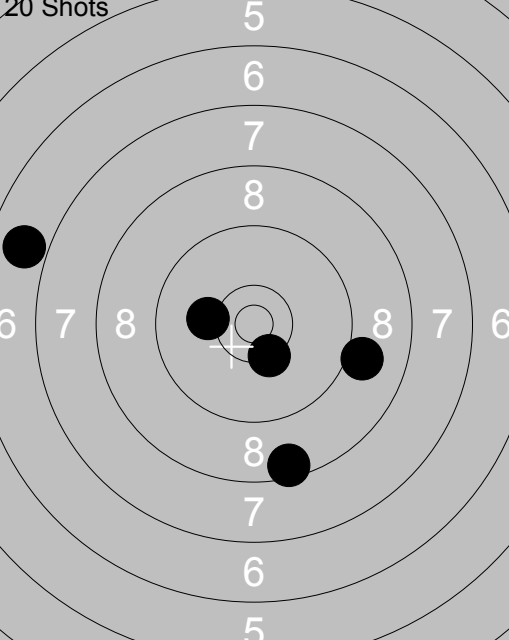
<p>20 Shots</p> 	<p>16: 8.5 ↘ 17: 6.9 ← 18: 10.2 ← 19: 9.1 → 20: *10.4 ↘</p> <p>Series 43.0 Total 178.0</p>	
--	--	--

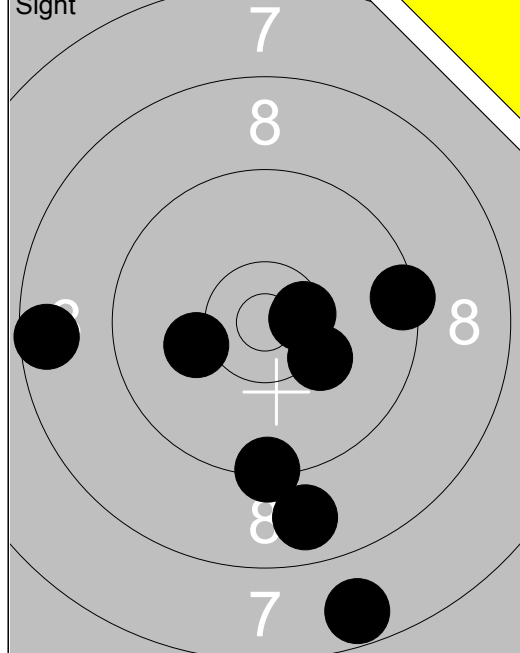

1: 7.7 ↓
2: 8.8 ↓
3: 9.4 →
4: 9.4 ↓
5: *10.5 →
6: *10.6 →
7: 10.2 ↘
8: 10.2 ←
9: 8.6 ←

Series	81.0
Total	0.0

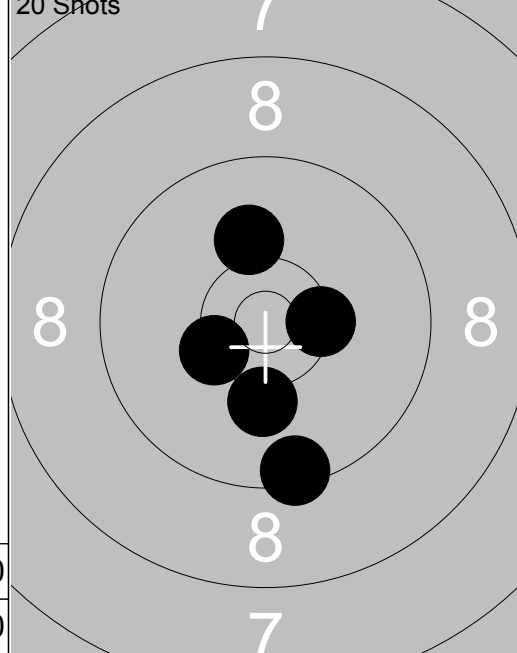

1: 10.2 ↓
2: *10.4 ↙
3: 10.1 ↑
4: *10.4 →
5: 9.4 ↓

Series	49.0
Total	49.0

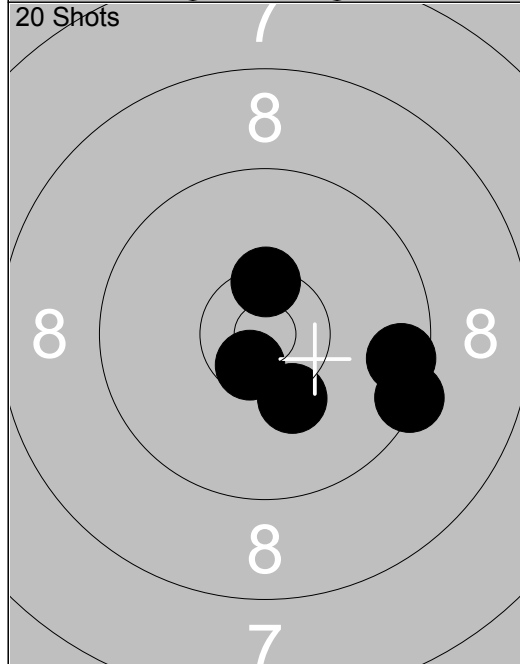

6: *10.6 ↙
7: *10.4 ↑
8: 10.3 ↓
9: 9.4 →
10: 9.6 →

Series	48.0
Total	97.0

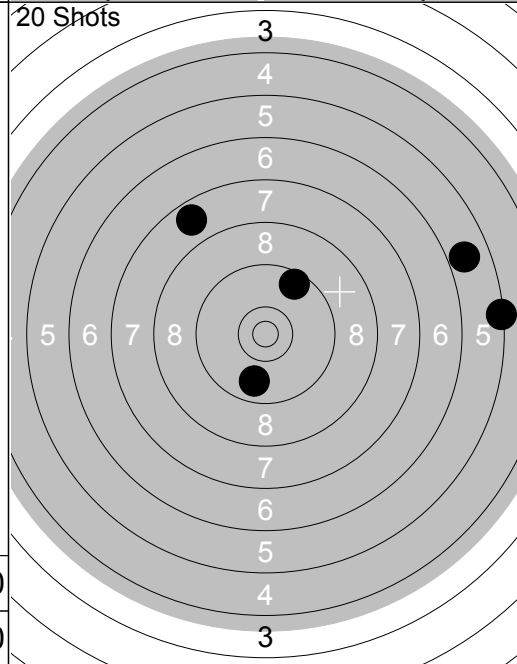

11: 7.7 ↖
12: 5.9 →
13: 9.6 ↗
14: 5.4 →
15: 9.8 ↓

Series	35.0
Total	132.0

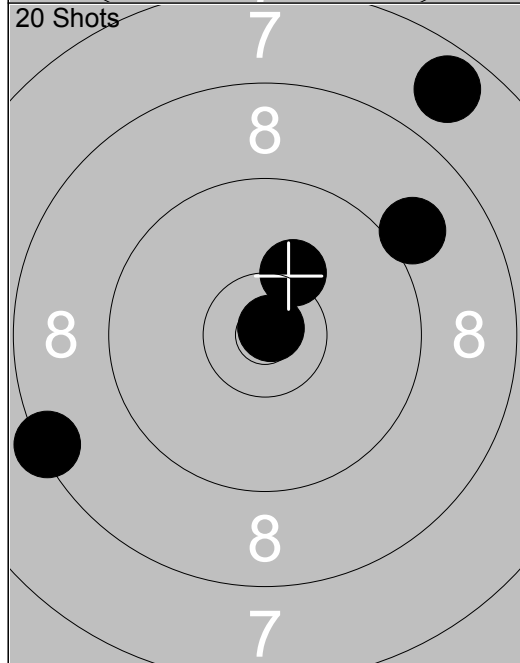

16: 7.7 ↗
17: 9.0 ↗
18: 10.2 ↗
19: *10.9 ↗
20: 8.4 ←

Series	44.0
Total	176.0



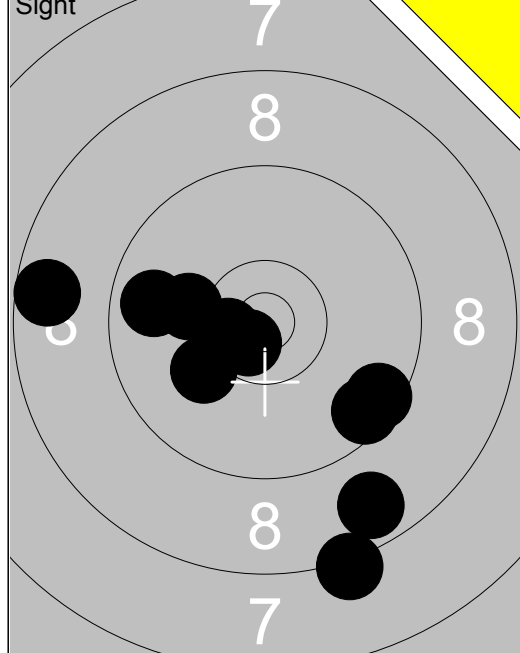

1:	8.7	↘
2:	8.2	↘
3:	9.5	↘
4:	9.5	↘
5:	10.1	↙
6:	*10.5	↙
7:	9.8	←
8:	*10.7	↘
9:	8.6	←
10:	10.1	←
Series		91.0
Total		0.0

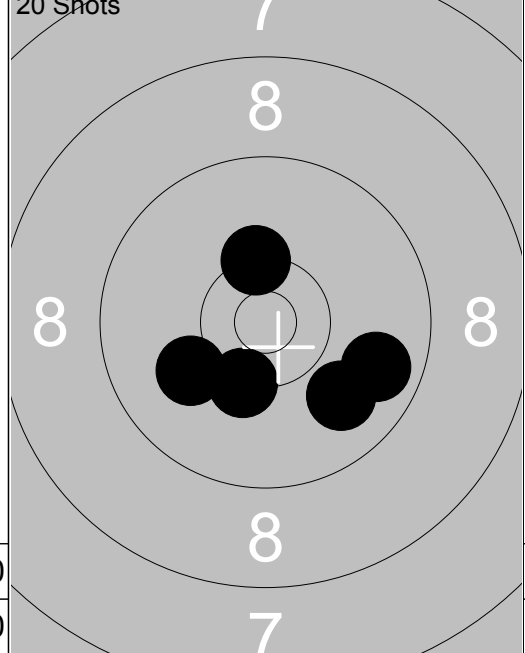

1:	10.1	↙
2:	*10.3	↘
3:	9.8	→
4:	9.9	↘
5:	*10.3	↗
Series		48.0
Total		48.0

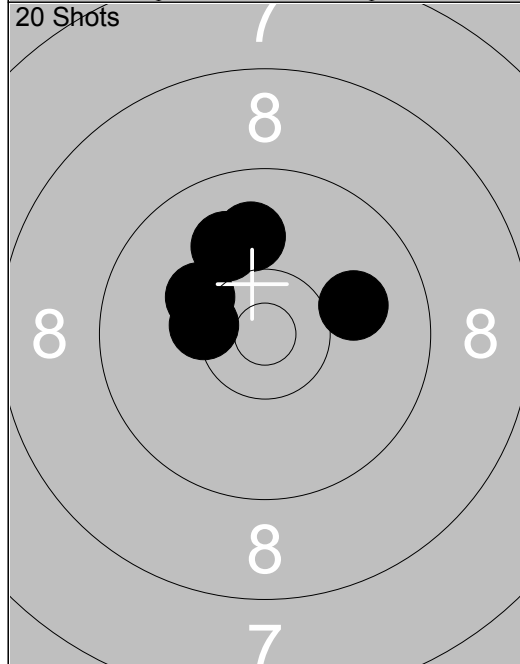

6:	10.0	↗
7:	10.0	↗
8:	*10.3	↙
9:	10.2	↙
10:	10.0	→
Series		50.0
Total		98.0

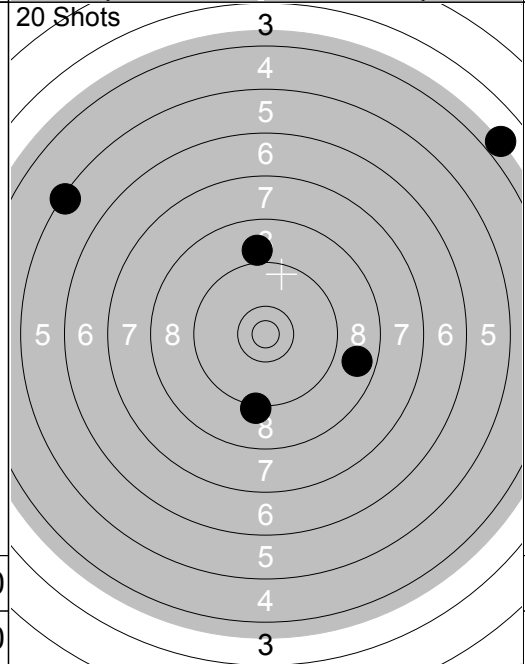

11:	5.4	↖
12:	3.9	↗
13:	9.2	↘
14:	8.8	→
15:	9.0	↗
Series		34.0
Total		132.0

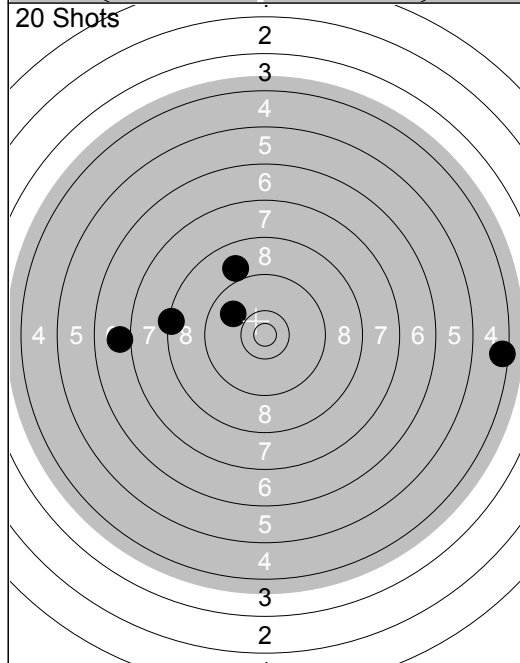

16:	9.9	↖
17:	4.5	→
18:	8.4	←
19:	7.0	←
20:	9.0	↗
Series		37.0
Total		169.0



	<p>1: 8.8 ↘                  2: 8.9 ↗                  3: 9.2 ↖                  4: 8.3 ↗                  5: 9.4 ↑                  6: *10.5 ↘                  7: *10.5 ↘                  8: 8.4 →                  9: 8.7 ↑                  10: 9.7 ↗</p>	
Series 87.0		Series 44.0
Total 0.0		Total 0.0

	<p>1: *10.8 ↘                  2: 9.6 ↓                  3: 10.1 ↗                  4: 9.7 ↖                  5: 10.1 ↗</p>	
Series 48.0		Series 50.0
Total 48.0		Total 98.0

	<p>11: 6.8 ↖                  12: 5.7 ↖                  13: 8.8 ↖                  14: 8.6 ↖                  15: 6.8 →</p>	
Series 33.0		Series 45.0
Total 131.0		Total 176.0

Relay <b>5</b>	Lane <b>1</b>	<b>Peter Lundqvist</b>
-------------------	------------------	------------------------

50m	Ununge	Sen-L	St
-----	--------	-------	----

08.07.2014	Tavelträffen Korthäll 2014	Ramselefors SKF
------------	----------------------------	-----------------

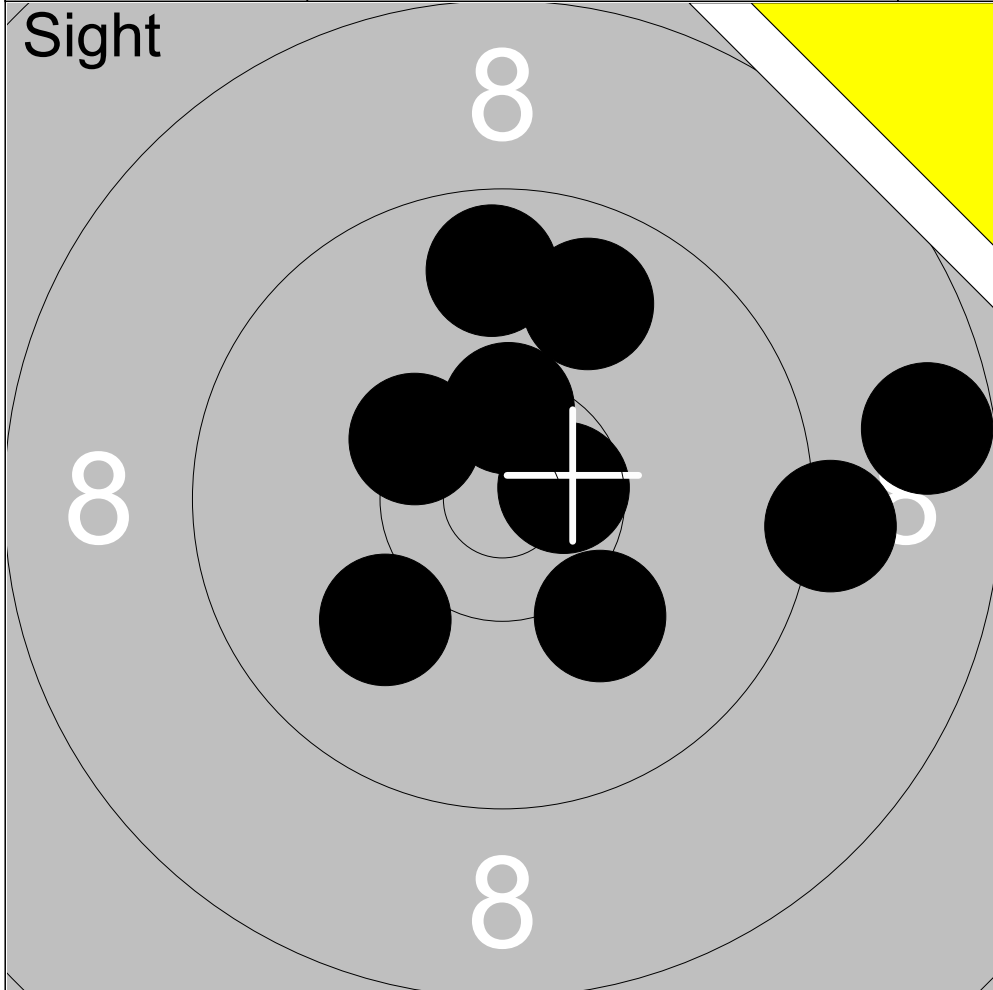

1:	9.7	↑
2:	10.1	↙
3:	8.7	→
4:	10.1	↘
5:	*10.5	↑
6:	*10.6	→
7:	9.2	→
8:	9.8	↗
9:	*10.4	↖

Series	85.0
Total	0.0

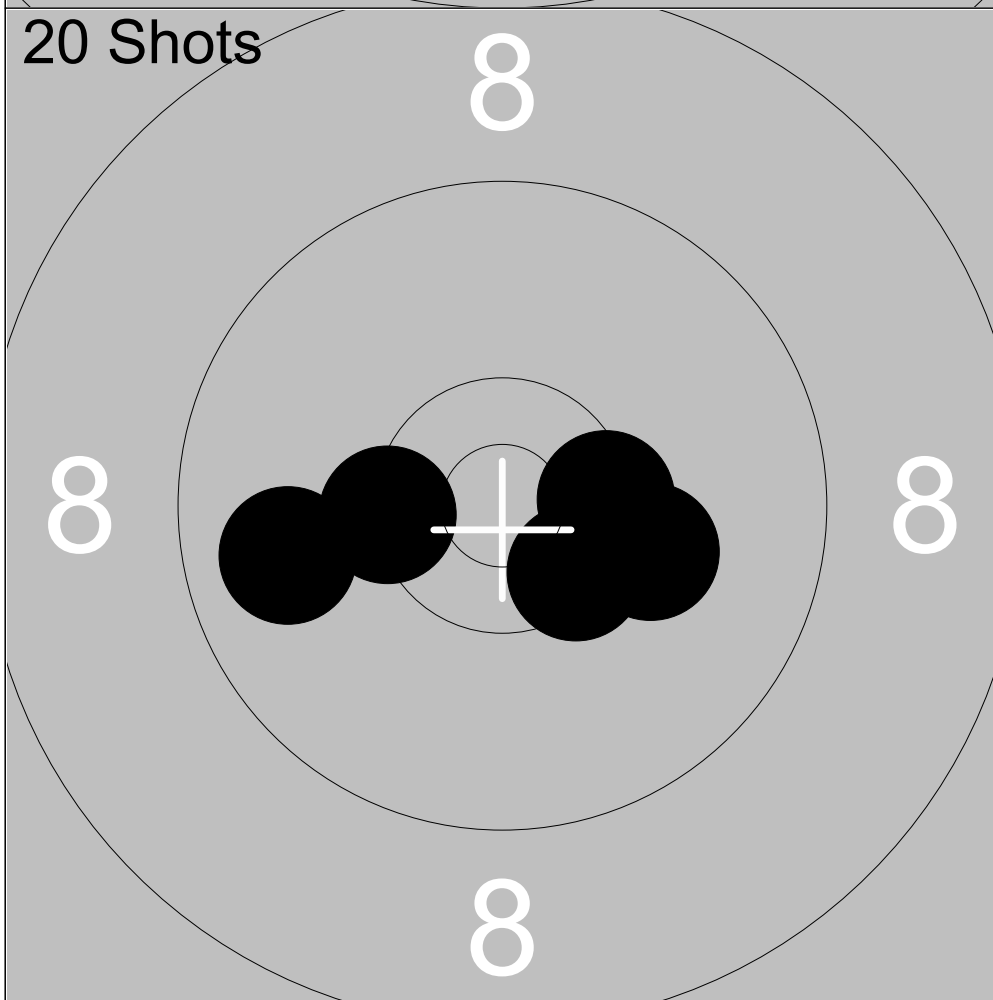

1:	*10.4	←
2:	9.8	←
3:	*10.4	→
4:	10.2	→
5:	*10.4	↘

Series	49.0
Total	49.0

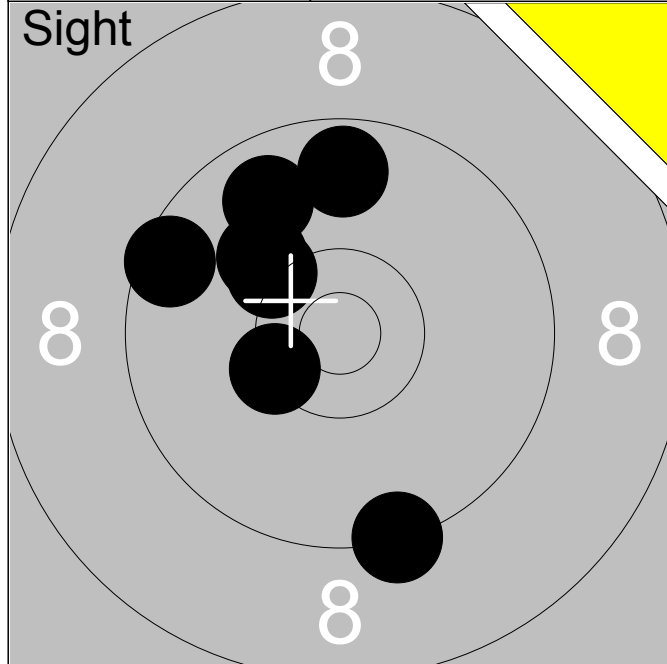

1:	10.3	↗
2:	10.1	↗
3:	9.5	↖
4:	9.3	↓
5:	*10.4	↙
6:	9.7	↑
7:	9.8	↖

Series	66.0
Total	0.0

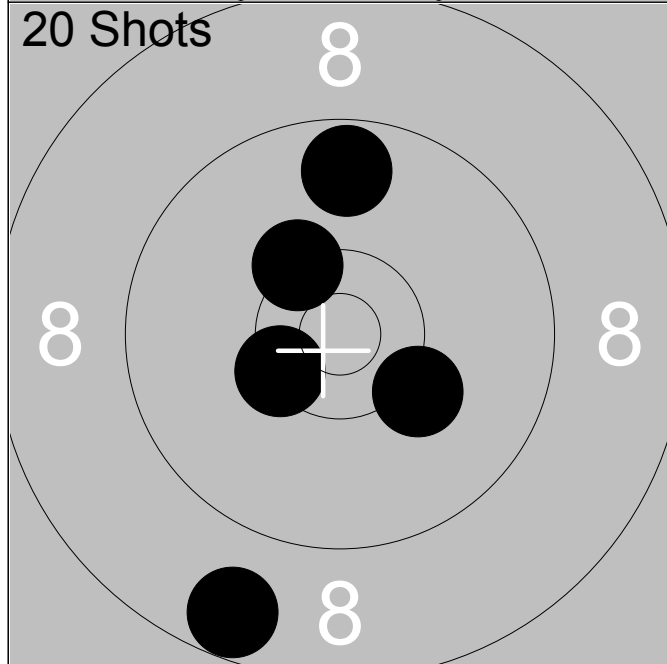

1:	*10.3	↖
2:	9.7	↑
3:	10.2	↘
4:	*10.4	↙
5:	8.7	↓

Series	47.0
Total	47.0



6:	9.3	↘
7:	10.1	→
8:	*10.3	↖

Series	29.0
Total	76.0

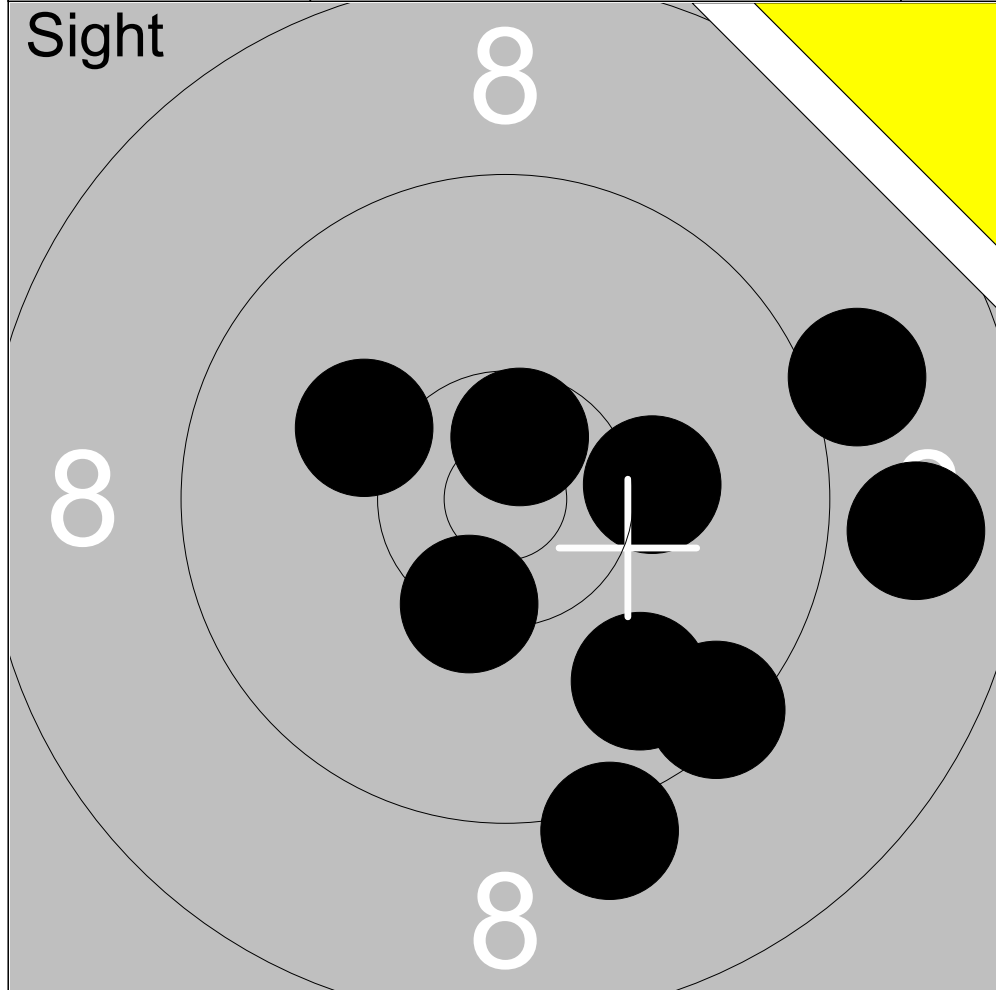

1:	9.1	→
2:	9.4	↘
3:	9.2	↘
4:	8.9	→
5:	*10.6	↗
6:	10.1	↖
7:	*10.4	↘
8:	9.8	↘
9:	10.2	→

Series	84.0
Total	0.0



1:	*10.3	↖
2:	*10.5	↘
3:	*10.5	↘

Series	30.0
Total	30.0

Relay <b>5</b>	Lane <b>4</b>	<b>Tony Jansson</b>	
-------------------	------------------	---------------------	--

50m	Ununge	Vet-L	St
-----	--------	-------	----

08.07.2014	Tavelträffen Korthäll 2014	Ramselefors SKF
------------	----------------------------	-----------------

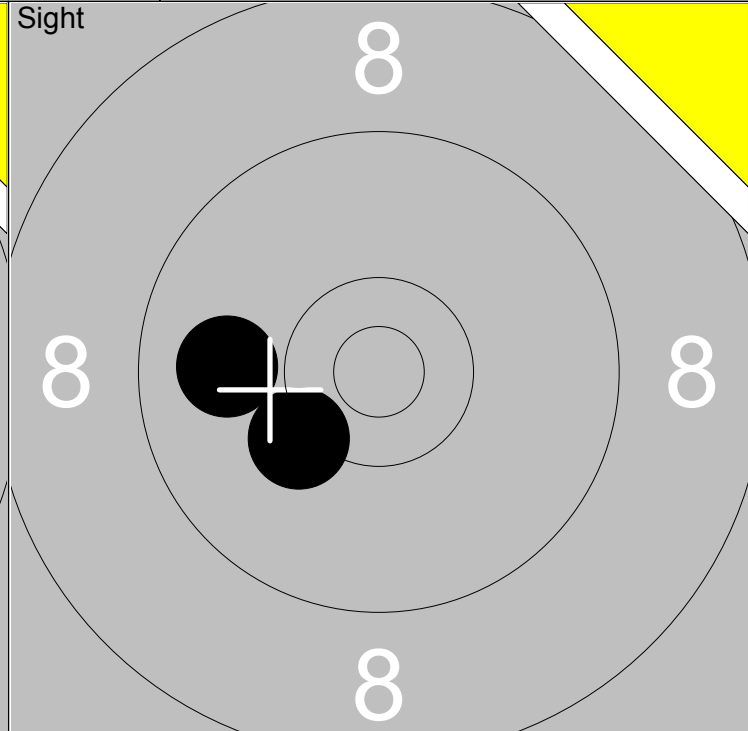
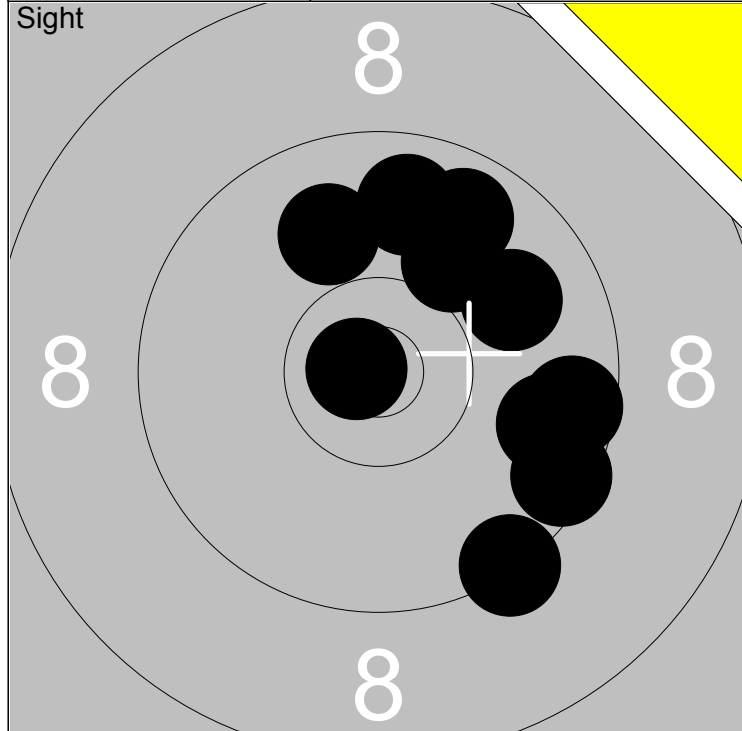

1: 9.5 →	6: 9.6 →	Series 92.0
2: 9.3 ↓	7: 9.9 ↗	
3: 9.8 ↑	8: 9.9 ↗	Total 0.0
4: 9.7 →	9: 9.7 ↗	
5: 10.0 ↗	10: *10.8 ←	

11: 9.9 ←	Series 19.0
12: 10.2 ↙	
	Total 0.0

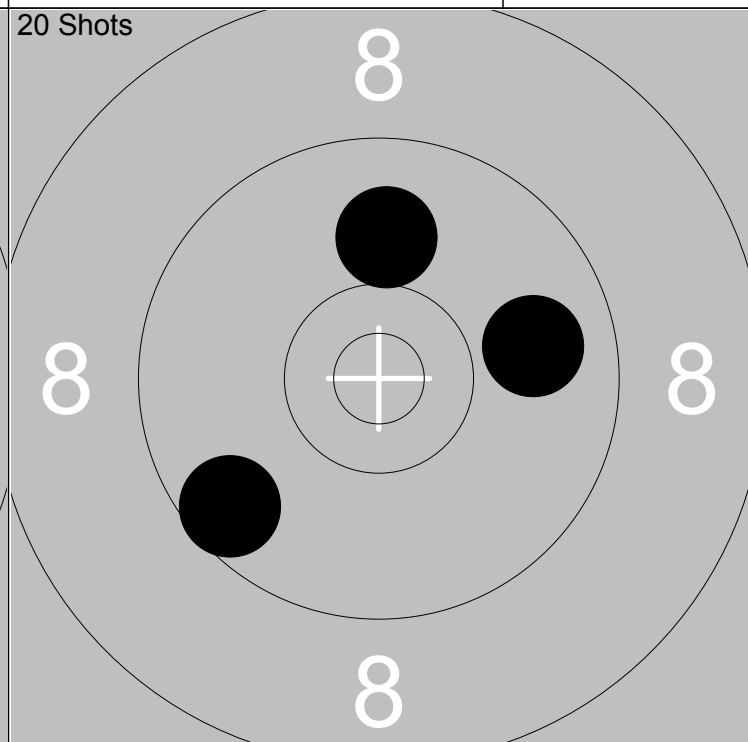
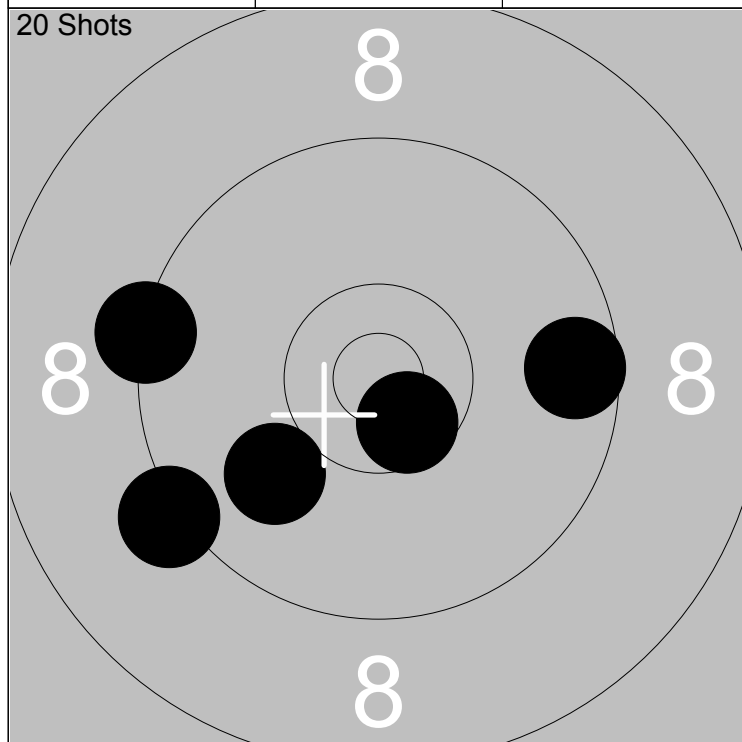

1: 9.6 →	Series 47.0
2: 9.3 ←	
3: 10.0 ↙	Total 47.0
4: *10.6 ↙	
5: 9.2 ↙	

6: 10.0 ↑	Series 28.0
7: 9.6 ↙	
8: 9.9 →	Total 75.0



1:	*10.5	↙
2:	10.0	←
3:	9.7	↗
4:	*10.7	↑
5:	*10.4	→
6:	9.6	↗
7:	9.4	↗
8:	7.1	↗
9:	*10.7	↙
10:	*10.8	↗

Series	<b>94.0</b>
Total	<b>0.0</b>

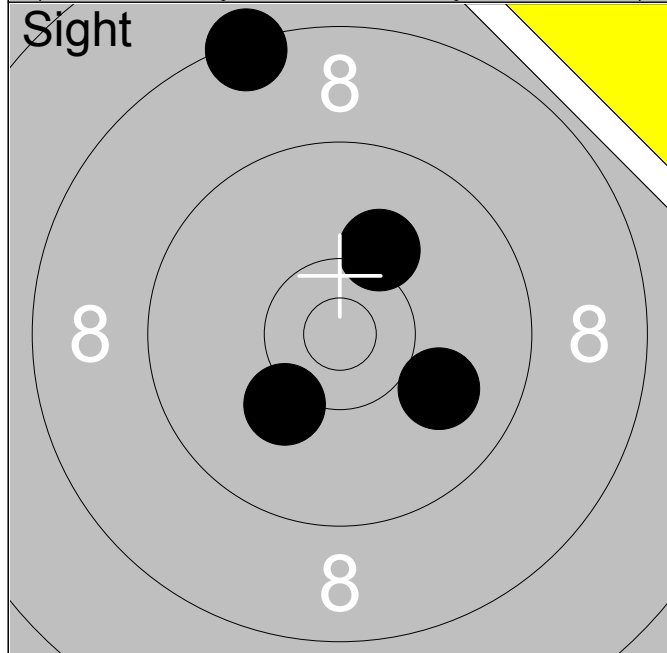

11:	8.4	↖
12:	10.2	↗
13:	10.0	↘
14:	10.2	↙

Series	<b>38.0</b>
Total	<b>0.0</b>

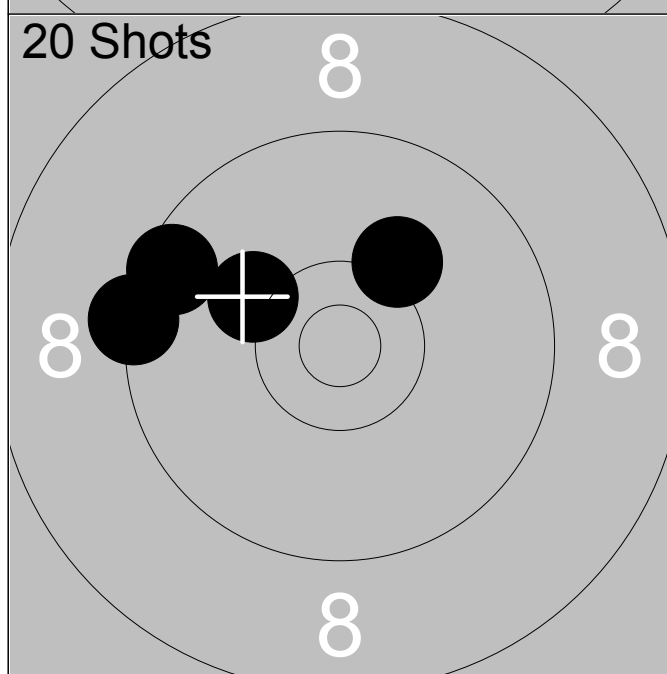

1:	9.5	↖
2:	9.3	←
3:	10.2	↗
4:	10.2	↗

Series	<b>38.0</b>
Total	<b>38.0</b>

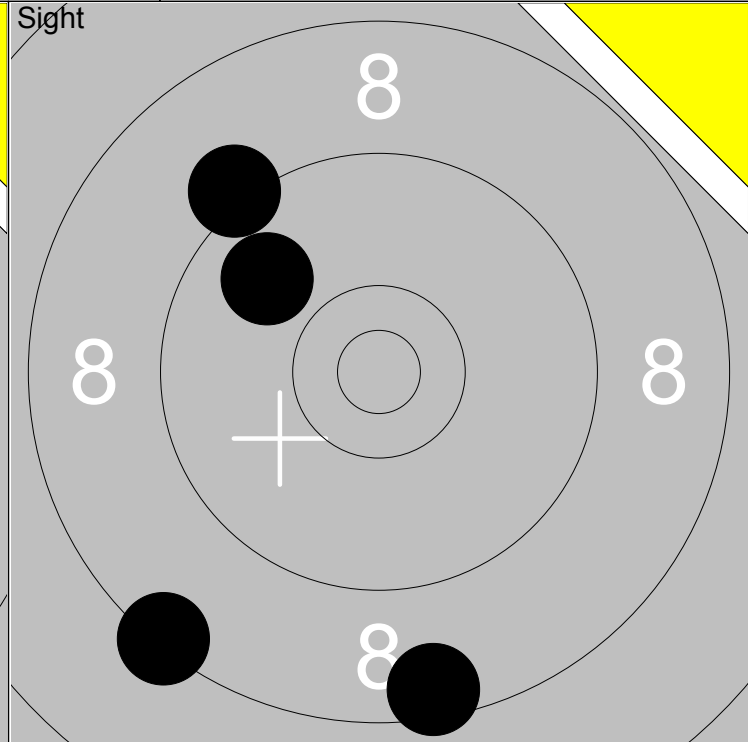
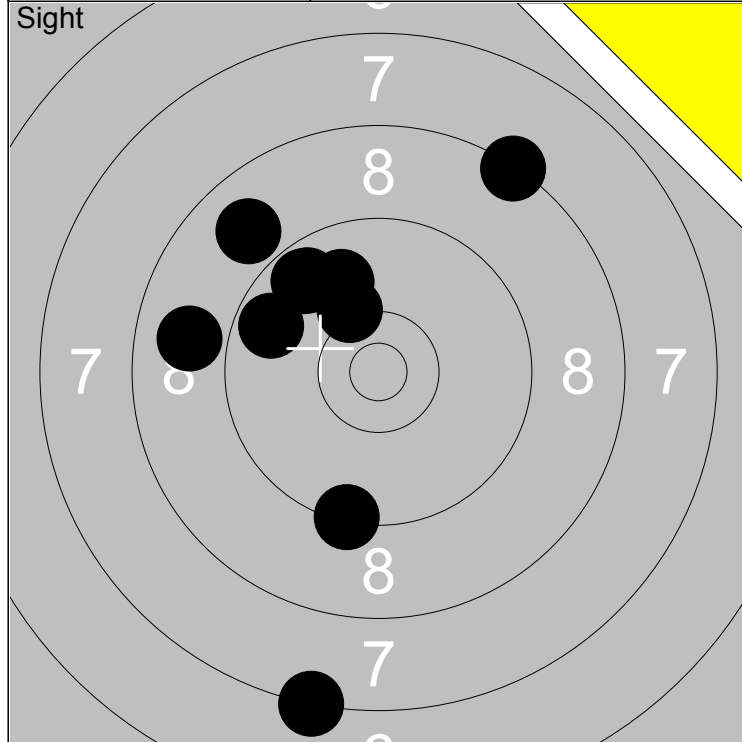

1: 9.4 ↓	6: 8.3 ↗	Series	86.0
2: 9.9 ↗	7: 9.7 ↗		
3: 8.9 ←	8: 9.7 ↗	Total	0.0
4: 8.9 ↗	9: 10.2 ↗		
5: 9.7 ←	10: 7.3 ↓		

11: 8.4 ↙	Series	34.0
12: 8.5 ↓		
13: 9.9 ↗	Total	0.0
14: 9.2 ↗		

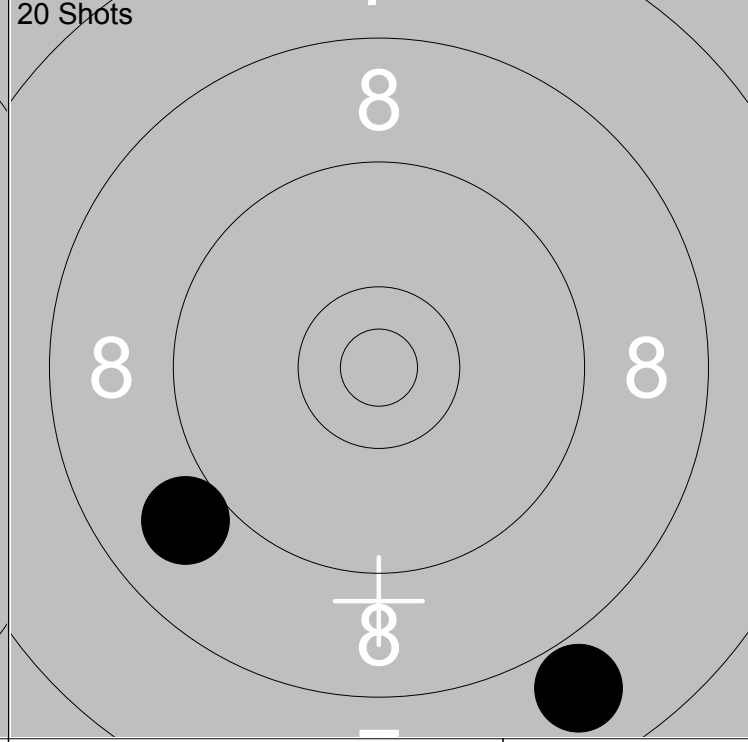
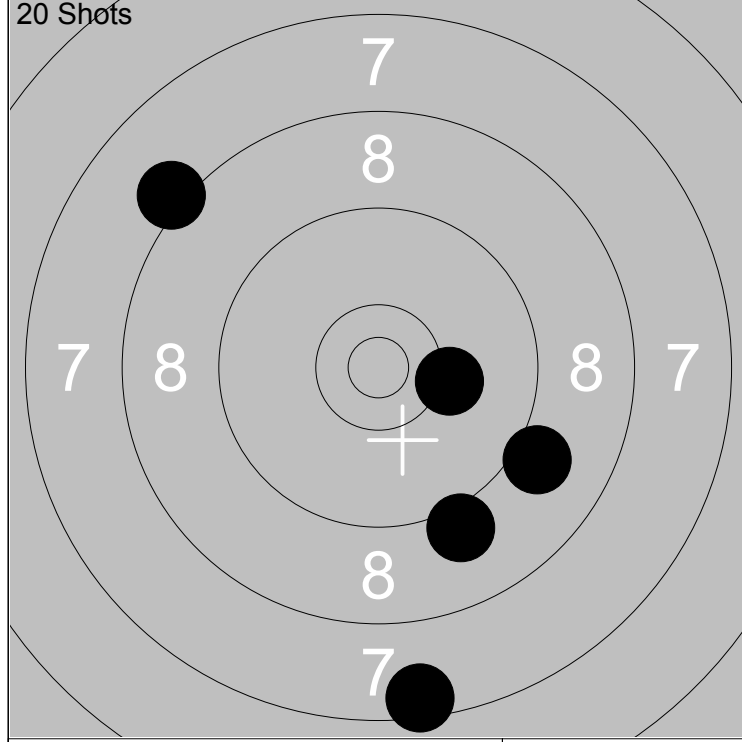

1: 9.1 ↓	Series	43.0
2: 10.2 →		
3: 9.1 ↓	Total	43.0
4: 7.5 ↓		
5: 8.2 ↗		

6: 7.9 ↓	Series	16.0
7: 9.0 ↙		
Total 59.0		

Relay	Lane	Berndt Steffen		
5	8			

50m	Frötuna	Vet-L	St
-----	---------	-------	----

08.07.2014	Tavelträffen Korthäll 2014	Ramselefors SKF
------------	----------------------------	-----------------

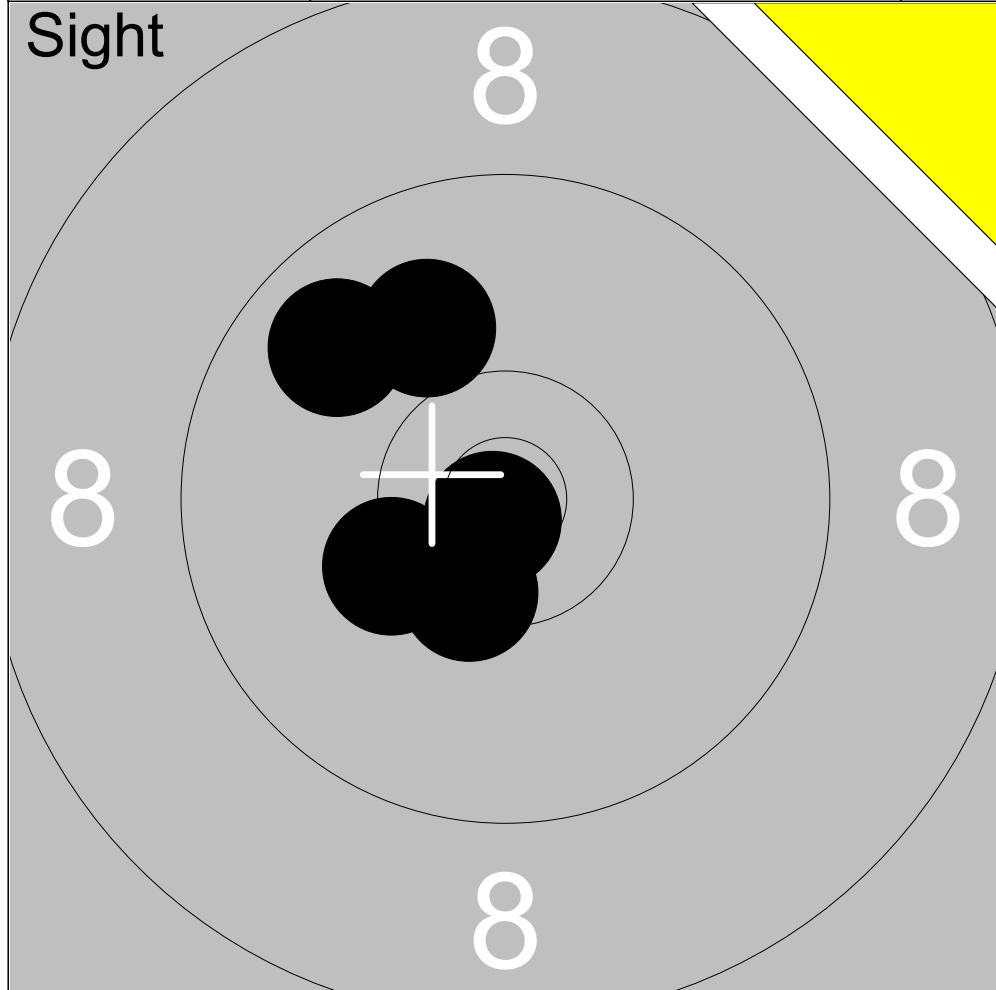

1:	*10.8	↙
2:	10.0	↗
3:	9.8	↖
4:	10.3	↖
5:	*10.4	↙

Series	49.0
Total	0.0

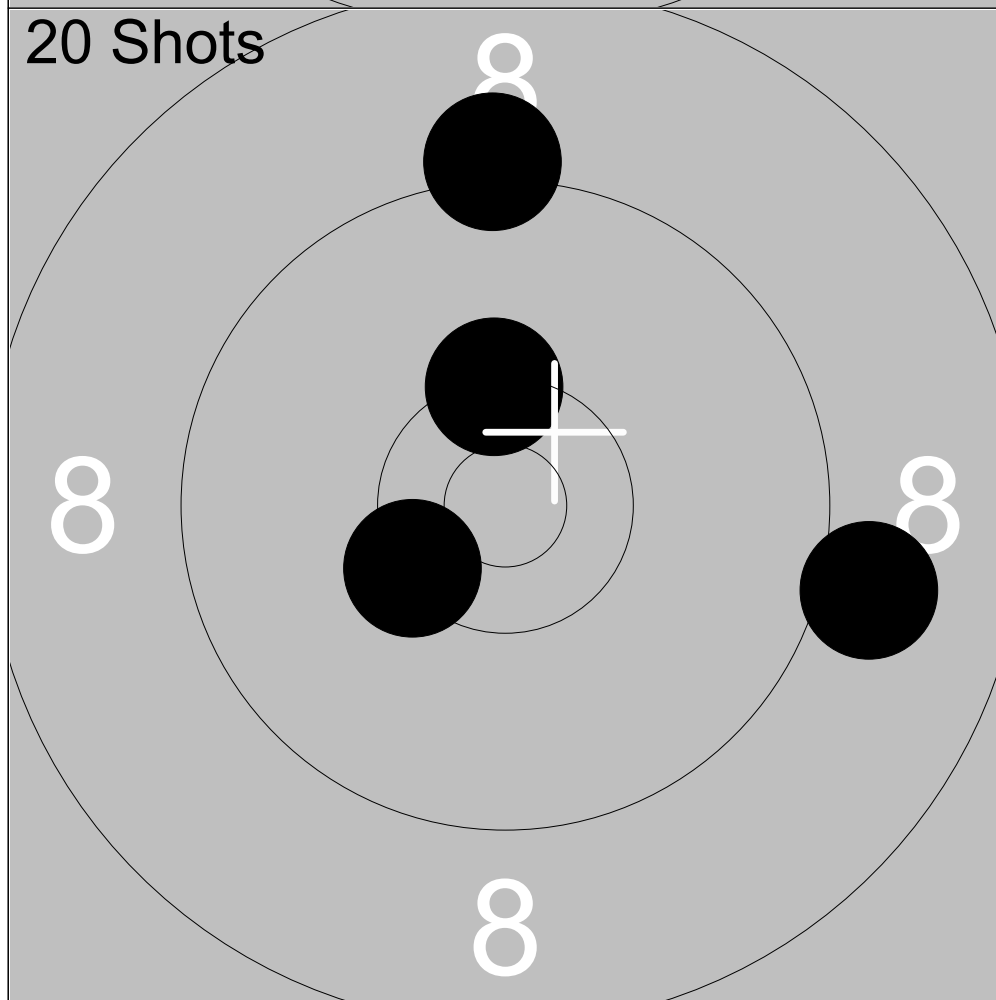

1:	*10.3	↑
2:	*10.4	↖
3:	9.2	↑
4:	9.0	→

Series	38.0
Total	38.0



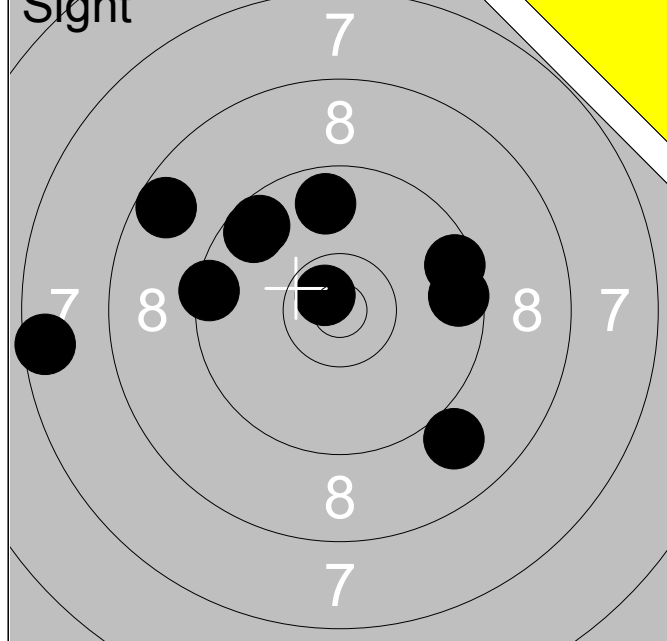

1:	*10.7	↗
2:	7.6	←
3:	9.4	←
4:	8.6	↗
5:	9.0	↘
6:	9.6	↗
7:	9.6	→
8:	9.5	↗
9:	9.7	↑
10:	9.6	↗

Series	88.0
Total	0.0

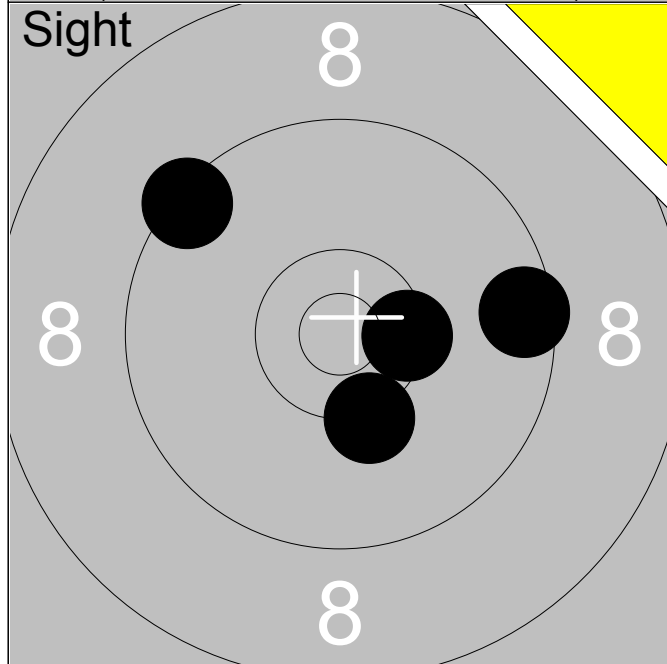

11:	9.5	→
12:	10.3	↘
13:	*10.4	→
14:	9.4	↗

Series	38.0
Total	0.0



1:	8.3	→
2:	9.3	↘
3:	9.8	←

Series	26.0
Total	26.0

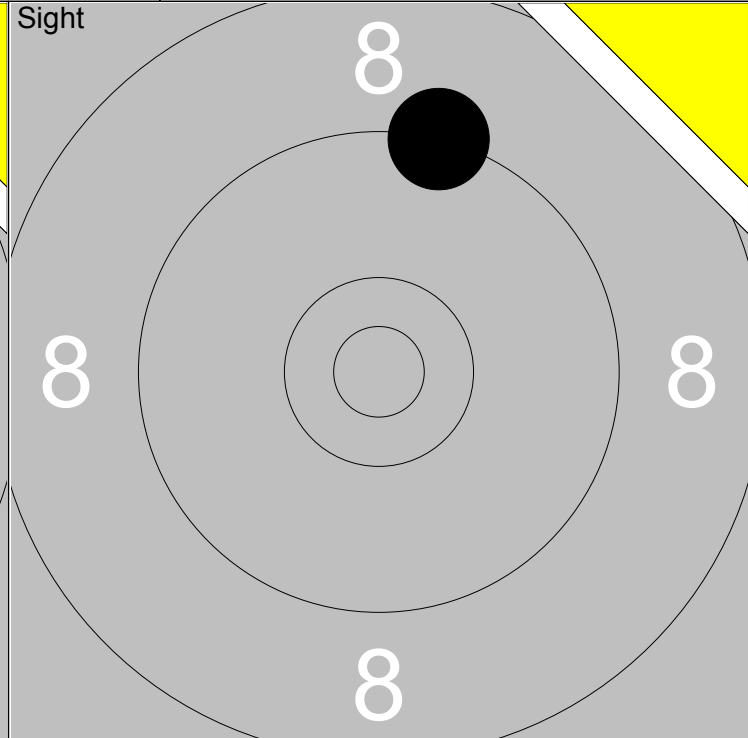
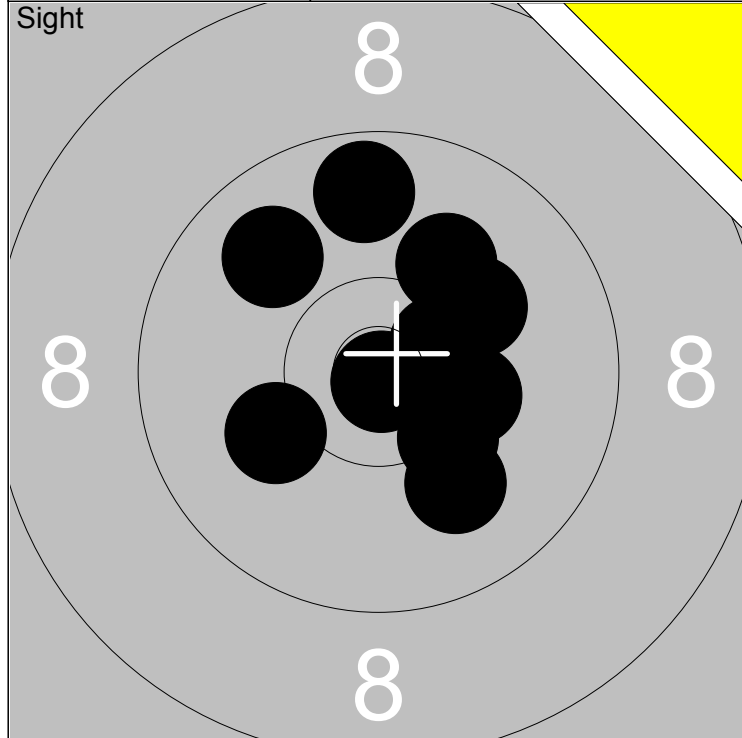

1: 10.0 ↘	6: 9.9 ↖	Series	98.0
2: 10.1 ↗	7: *10.5 →		
3: *10.3 →	8: 10.1 ↗	Total	0.0
4: *10.3 ↘	9: *10.9 ↘		
5: 9.7 ↑	10: 10.1 ↙		

11: 9.3 ↑	Series	9.0
	Total	0.0

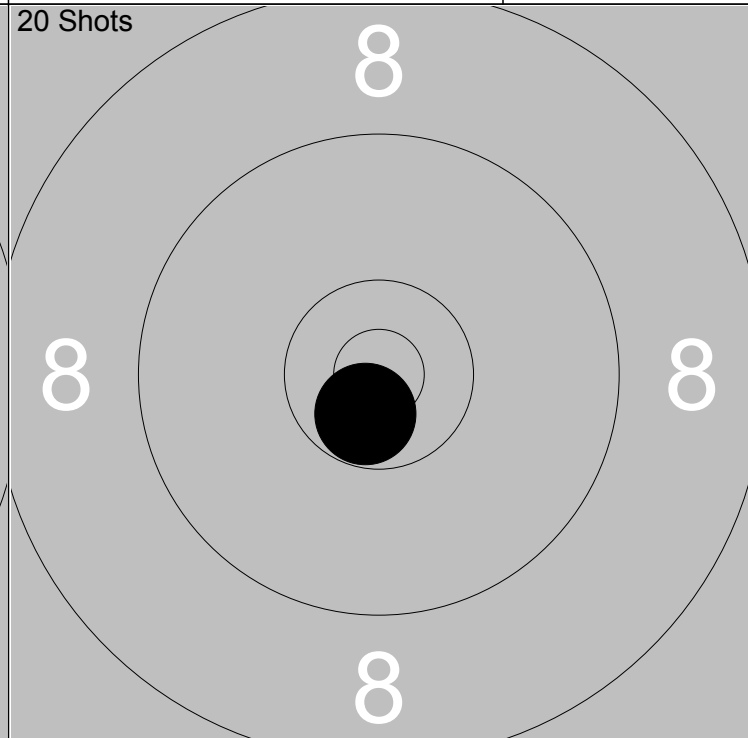
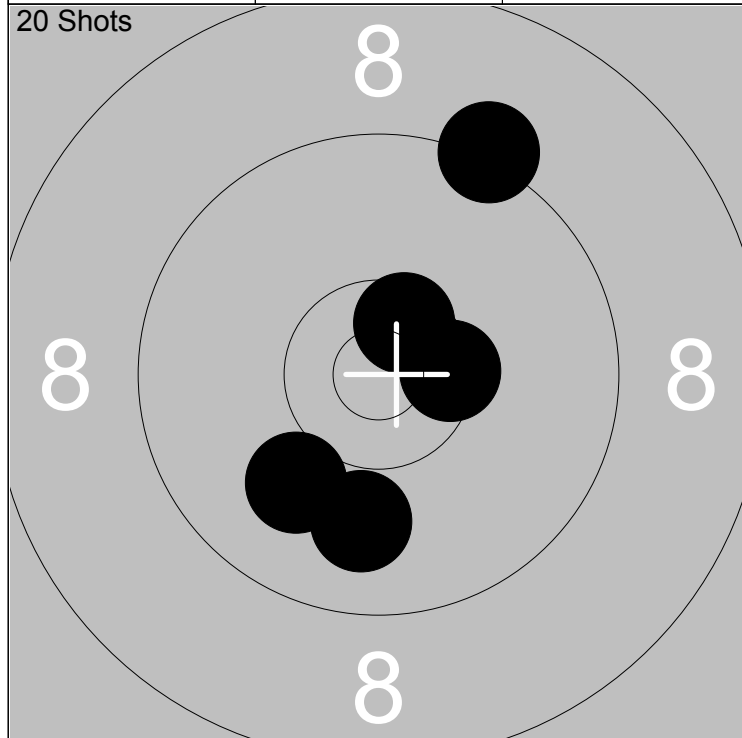

1: *10.5 →	Series	48.0
2: *10.6 ↗		
3: 9.2 ↗	Total	48.0
4: 9.9 ↘		
5: 10.0 ↙		

6: *10.7 ↘	Series	10.0
	Total	58.0

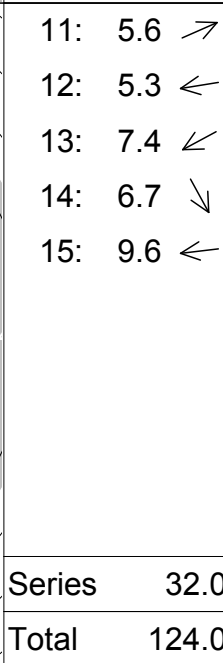
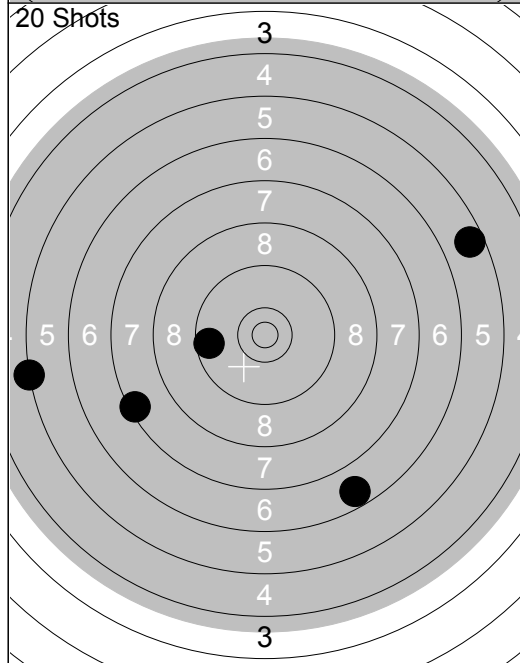
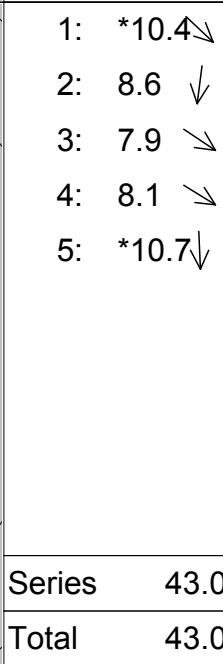
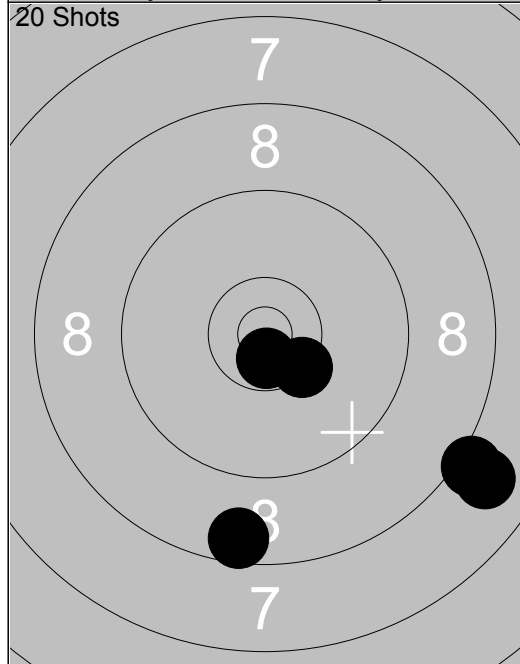
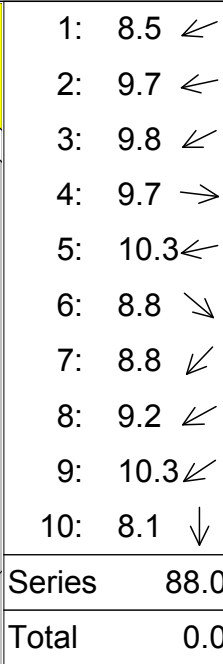
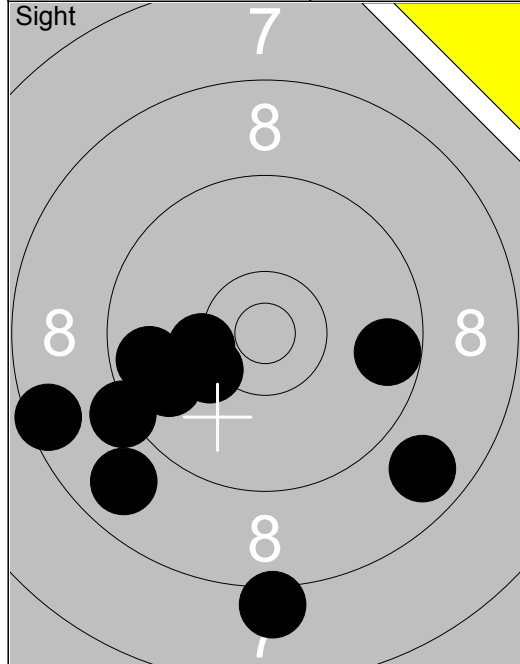

	1: 9.1 ↘		11: 9.7 →
	2: 8.9 ↙		12: 10.3 ↖
	3: 9.6 ←		
	4: 9.8 ↖		
	5: 8.5 ↖		
	6: 10.1 ↙		
	7: 8.6 ↖		
	8: *10.3 ↗		
	9: 10.3 →		
	10: 9.9 ←		
Series 90.0		Series 19.0	
Total 0.0		Total 0.0	

	1: 8.1 →		6: 9.4 ↗
	2: 9.3 ↗		7: 8.7 ↖
	3: 7.4 ↓		8: 10.0 ↓
	4: 9.2 ↗		9: 9.4 ↖
	5: *10.6 ↙		10: *10.4 →
Series 43.0		Series 46.0	
Total 43.0		Total 89.0	

	11: 7.7 ↑		16: 9.5 ↘
	12: 9.1 ↓		17: *10.4 ↘
	13: 7.3 →		18: 7.1 →
	14: 8.8 ↙		19: *10.7 ↙
	15: 5.3 ↙		20: 7.1 ←
Series 36.0		Series 43.0	
Total 125.0		Total 168.0	

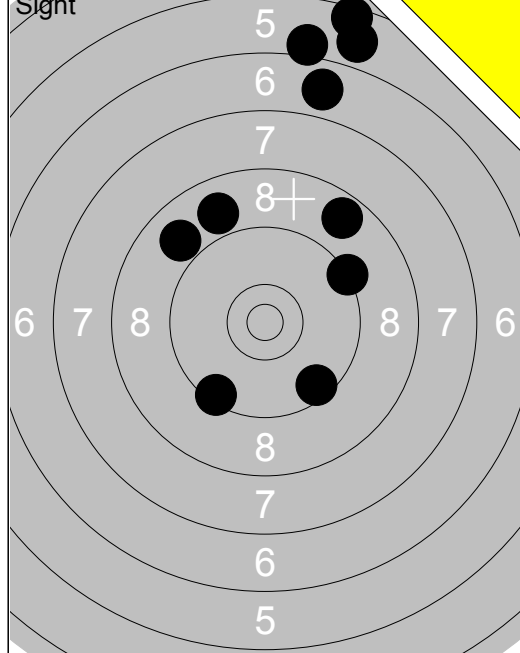

11:	7.2	↑
12:	10.2	↗
13:	8.7	↑
14:	10.2	↑
<b>Series</b>		<b>35.0</b>
<b>Total</b>		<b>0.0</b>

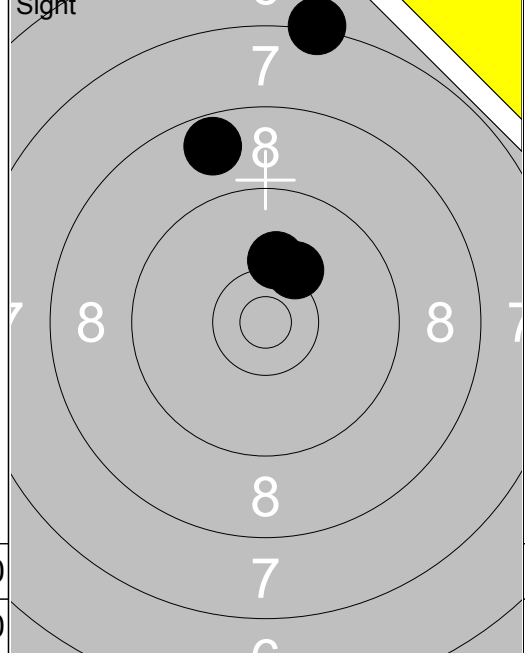

6:	8.7	↖
7:	9.1	↘
8:	9.7	↑
9:	10.1	↑
10:	9.3	→
<b>Series</b>		<b>45.0</b>
<b>Total</b>		<b>87.0</b>

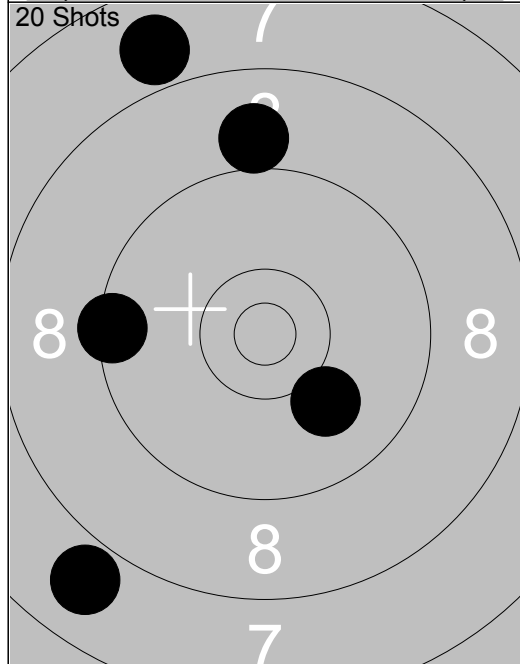

11:	7.7	→
12:	5.9	←
13:	*10.7	↘
14:	8.3	↑
15:	6.7	↖
<b>Series</b>		<b>36.0</b>
<b>Total</b>		<b>123.0</b>

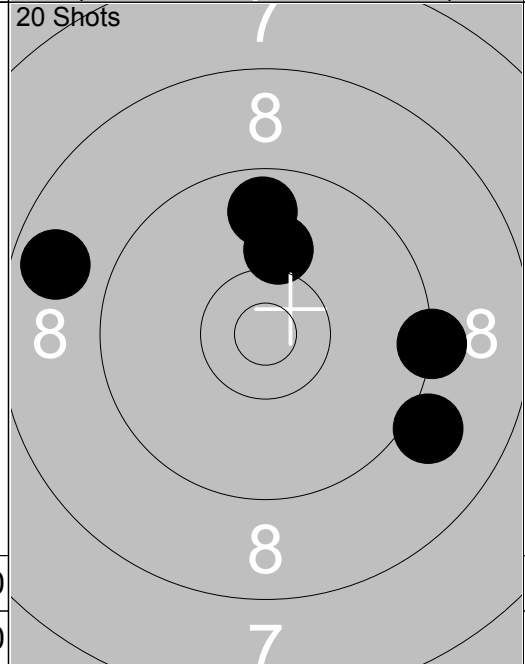

16:	9.7	↖
17:	9.9	↑
18:	7.7	↗
19:	8.1	↖
20:	8.5	↗
<b>Series</b>		<b>41.0</b>
<b>Total</b>		<b>164.0</b>

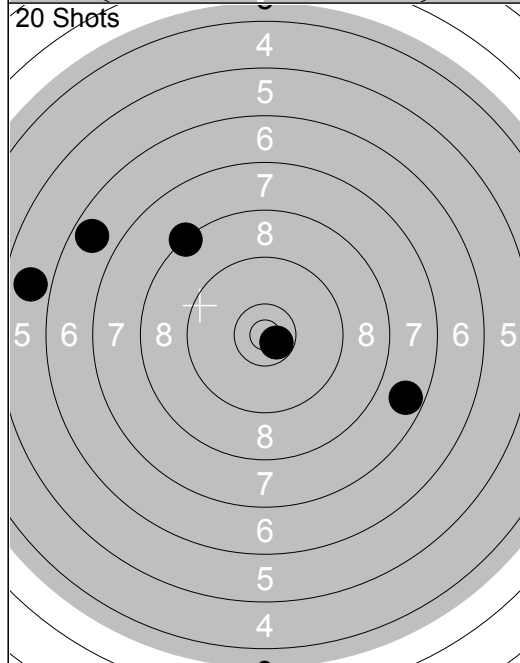

16:	9.7	↖
17:	9.9	↑
18:	7.7	↗
19:	8.1	↖
20:	8.5	↗
<b>Series</b>		<b>41.0</b>
<b>Total</b>		<b>164.0</b>

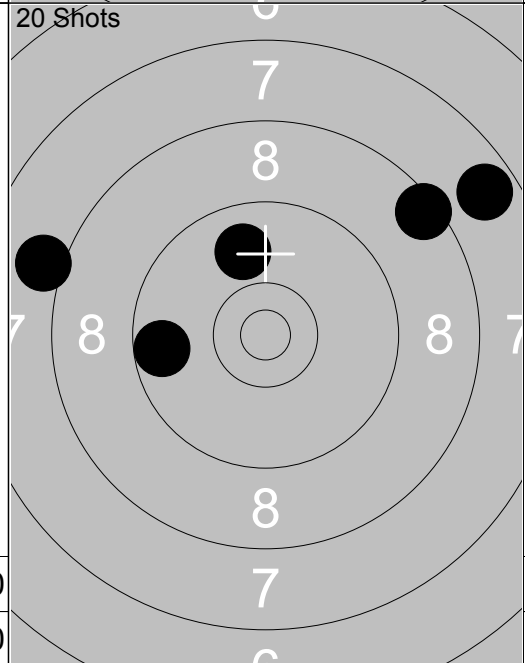

<b>Series</b>		<b>41.0</b>
<b>Total</b>		<b>164.0</b>

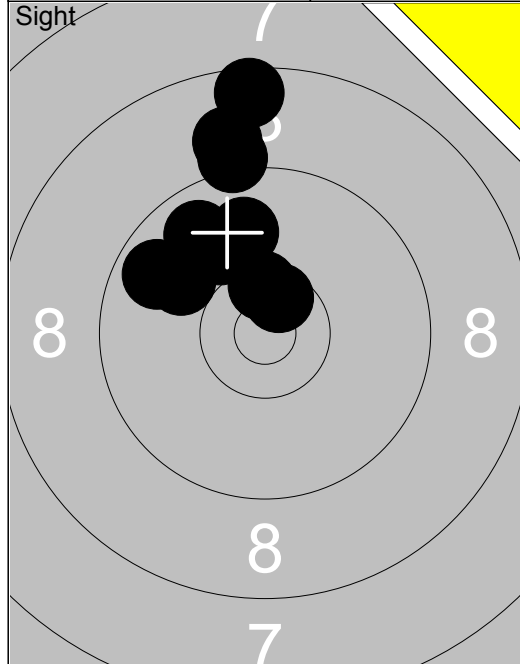

1:	8.5	↑
2:	10.0	↖
3:	9.2	↑
4:	9.0	↑
5:	9.9	↑
6:	*10.5	↑
7:	9.8	↖
8:	10.0	↖
9:	*10.6	↑
10:	9.7	↖
<b>Series</b>		<b>93.0</b>
<b>Total</b>		<b>0.0</b>

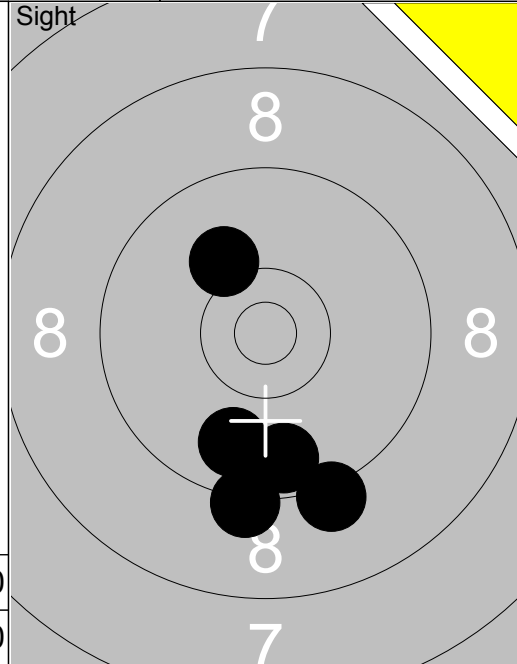

11:	9.2	↓
12:	9.7	↓
13:	9.2	↓
14:	9.8	↓
15:	10.1	↖
<b>Series</b>		<b>46.0</b>
<b>Total</b>		<b>0.0</b>

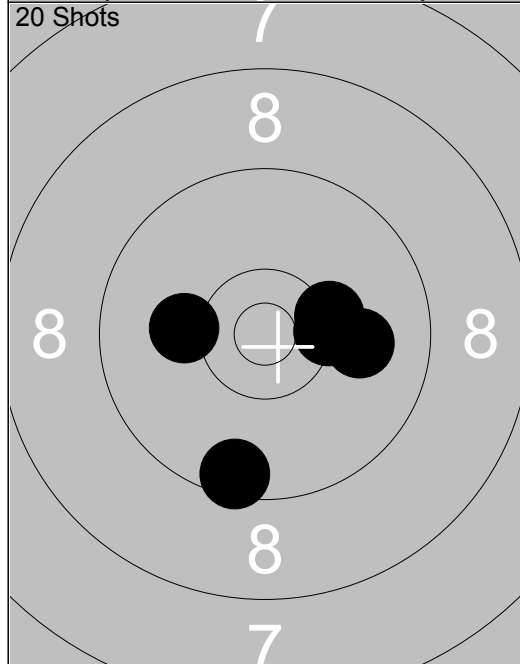

1:	10.0	→
2:	9.5	↓
3:	10.1	←
4:	*10.3	→
5:	10.3	→
<b>Series</b>		<b>49.0</b>
<b>Total</b>		<b>49.0</b>

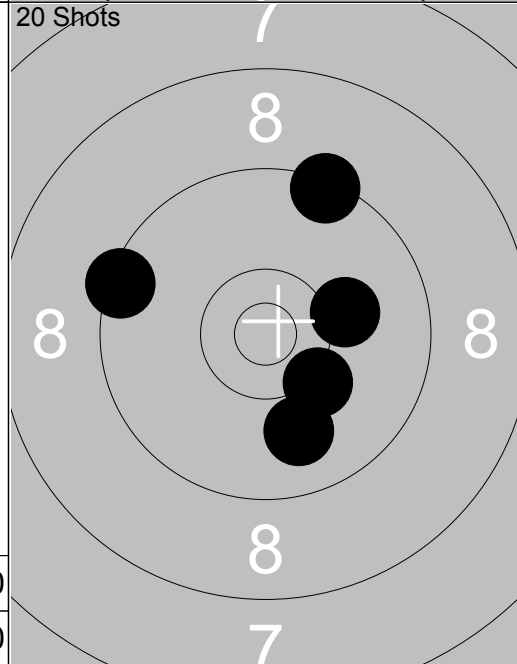

6:	9.9	↓
7:	9.4	↖
8:	9.4	↑
9:	10.2	↘
10:	10.1	→
<b>Series</b>		<b>47.0</b>
<b>Total</b>		<b>96.0</b>

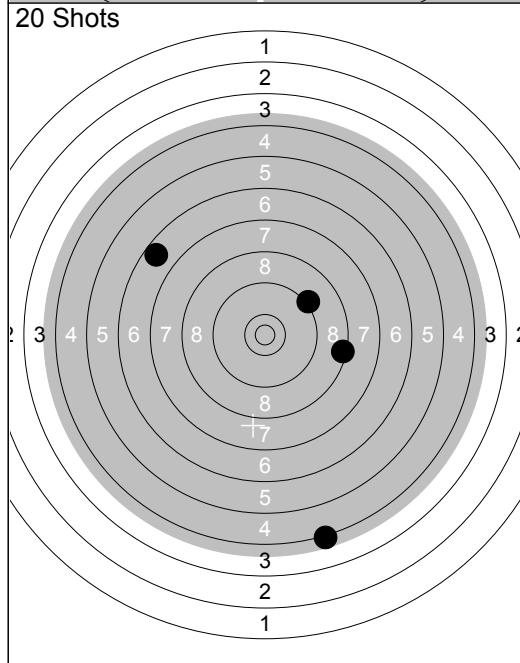

11:	4.2	↓
12:	0.0	↓
13:	8.4	→
14:	9.2	↗
15:	6.7	↖
<b>Series</b>		<b>27.0</b>
<b>Total</b>		<b>123.0</b>

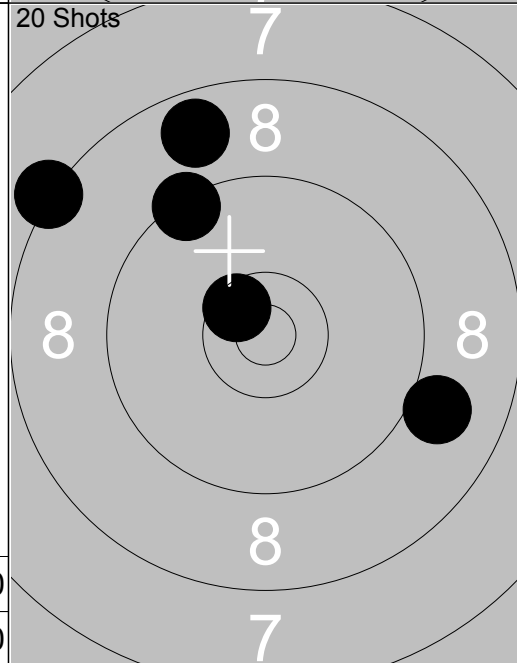

16:	9.0	↘
17:	8.7	↑
18:	9.4	↗
19:	8.3	↖
20:	*10.5	↖
<b>Series</b>		<b>44.0</b>
<b>Total</b>		<b>167.0</b>

<p>Sight</p>	<p>Sight</p>
--------------	--------------

<p>20 Shots</p>	<p>20 Shots</p>
-----------------	-----------------

<p>20 Shots</p>	<p>20 Shots</p>
-----------------	-----------------

--	--

--	--

--	--

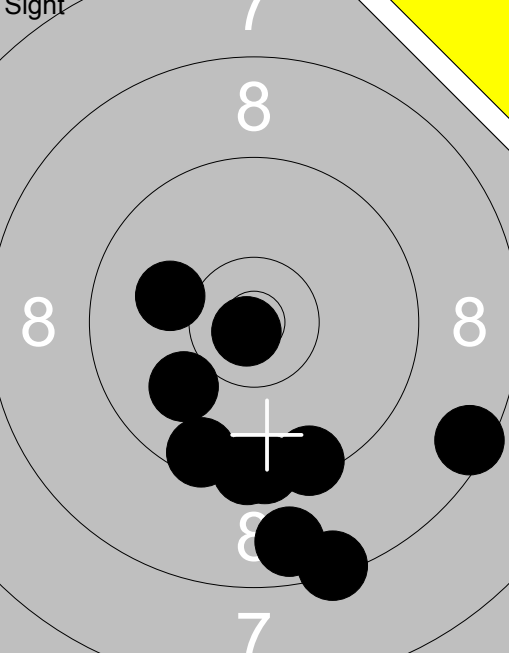
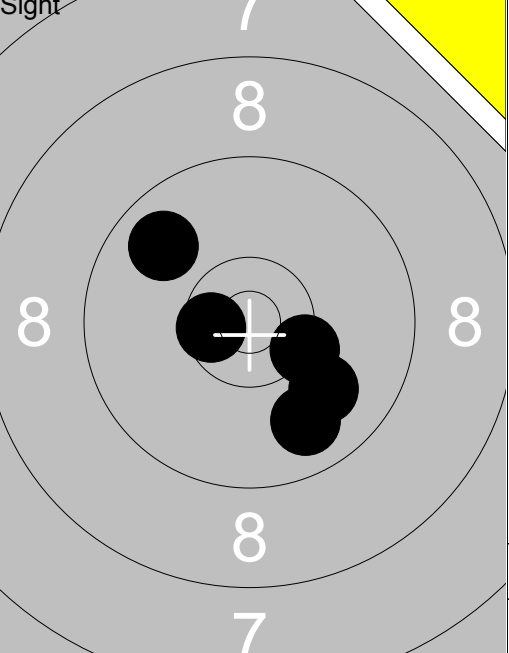
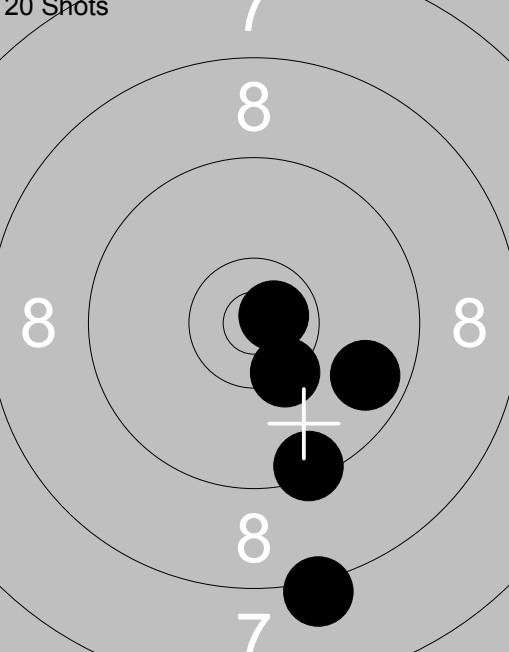
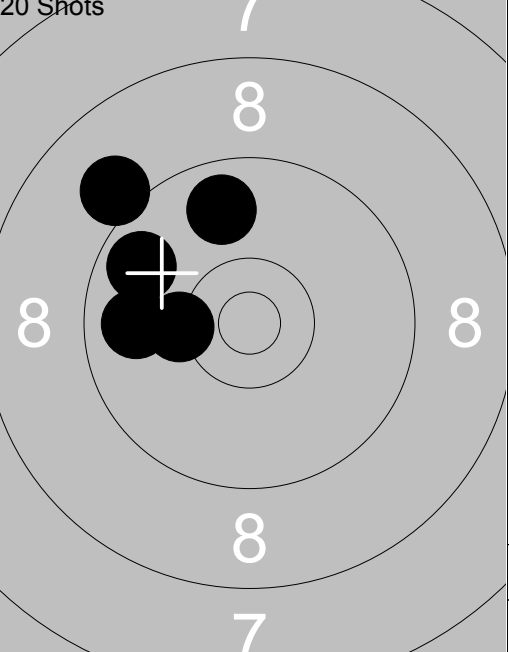
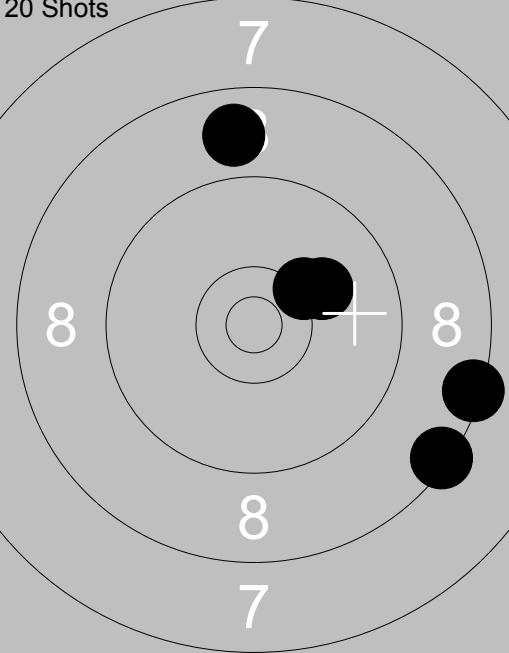
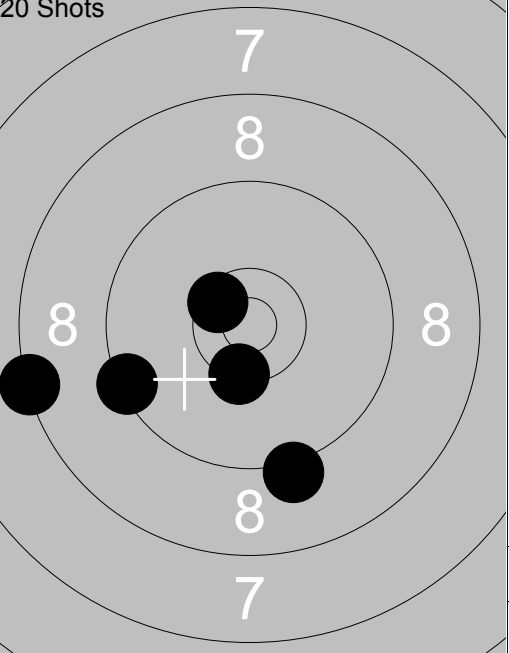

<p>Sight</p> 	<p>1: 10.1 ←</p> <p>2: 9.5 ↓</p> <p>3: 10.0 ↙</p> <p>4: 9.5 ↓</p> <p>5: 9.5 ↓</p> <p>6: 8.4 ↓</p> <p>7: 8.7 ↓</p> <p>8: 9.5 ↓</p> <p>9: 8.5 →</p> <p>10: *10.8 ↘</p> <hr/> <p>Series 90.0</p> <p>Total 0.0</p>	<p>Sight</p> 	<p>11: *10.6 ←</p> <p>12: *10.3 →</p> <p>13: 10.0 ↘</p> <p>14: 9.8 ↗</p> <p>15: 9.8 ↓</p> <hr/> <p>Series 48.0</p> <p>Total 0.0</p>
<p>20 Shots</p> 	<p>1: *10.4 ↘</p> <p>2: 9.7 →</p> <p>3: 9.4 ↓</p> <p>4: *10.7 →</p> <p>5: 8.2 ↓</p> <hr/> <p>Series 46.0</p> <p>Total 46.0</p>	<p>20 Shots</p> 	<p>6: 9.8 ←</p> <p>7: 9.7 ↙</p> <p>8: 9.1 ↗</p> <p>9: 9.8 ↑</p> <p>10: 10.2 ←</p> <hr/> <p>Series 46.0</p> <p>Total 92.0</p>
<p>20 Shots</p> 	<p>11: 8.4 →</p> <p>12: 8.8 ↑</p> <p>13: 8.4 →</p> <p>14: 10.1 →</p> <p>15: 10.3 →</p> <hr/> <p>Series 44.0</p> <p>Total 136.0</p>	<p>20 Shots</p> 	<p>16: *10.4 ↘</p> <p>17: 9.4 ↙</p> <p>18: 8.3 ←</p> <p>19: 9.2 ↓</p> <p>20: *10.5 ↘</p> <hr/> <p>Series 46.0</p> <p>Total 182.0</p>

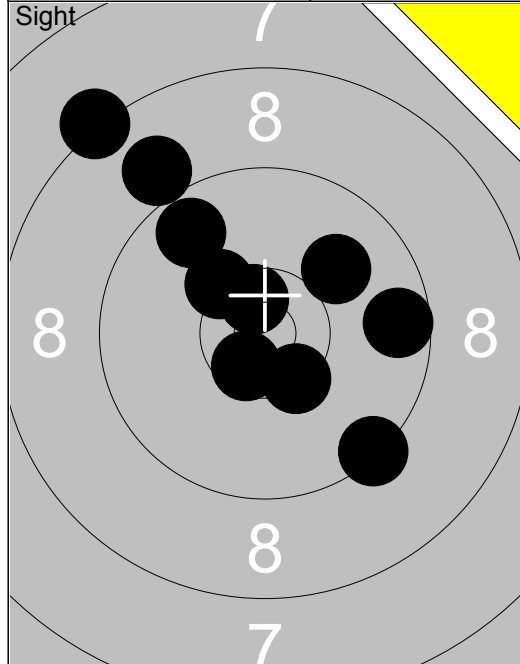

1:	8.3	↗
2:	9.7	↗
3:	9.0	↗
4:	10.3	↖
5:	10.0	↗
6:	*10.6	↘
7:	9.4	↘
8:	*10.6	↗
9:	9.6	→
10:	*10.4	↘

Series	94.0
Total	0.0

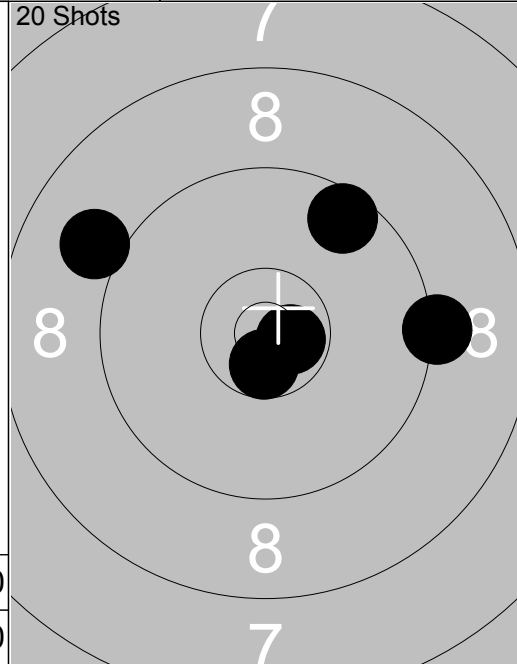

1:	9.2	→
2:	9.6	↗
3:	*10.6	↘
4:	*10.7	→
5:	9.0	↖

Series	47.0
Total	47.0

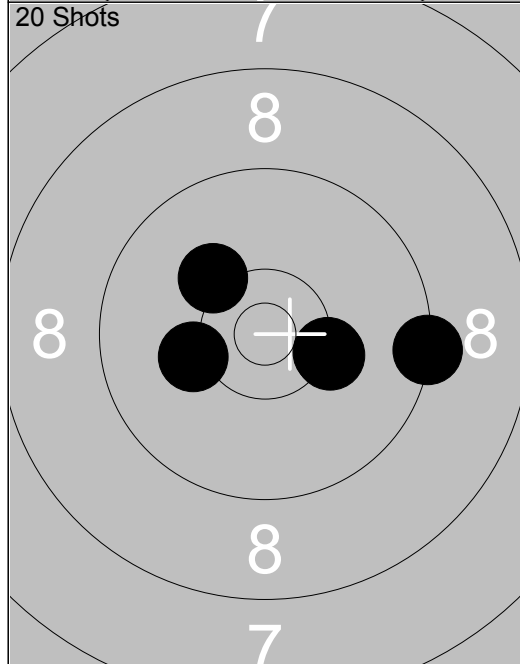

6:	9.3	→
7:	10.3	→
8:	10.2	↖
9:	*10.3	→
10:	10.2	↗

Series	49.0
Total	96.0

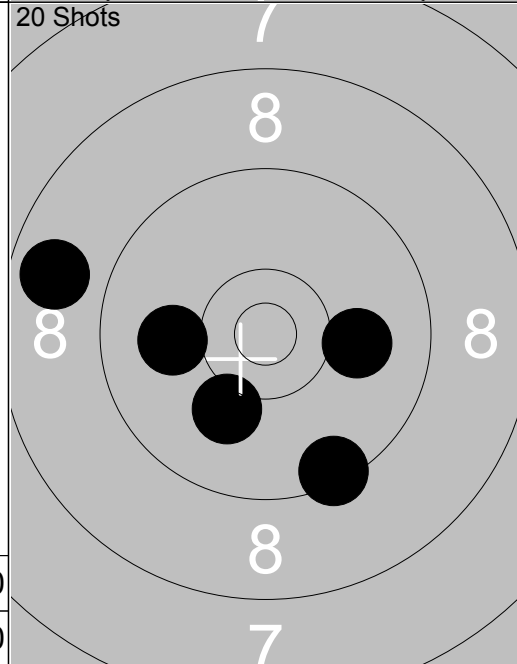

11:	8.8	↖
12:	10.0	↖
13:	10.0	→
14:	9.4	↘
15:	10.1	↘

Series	47.0
Total	143.0

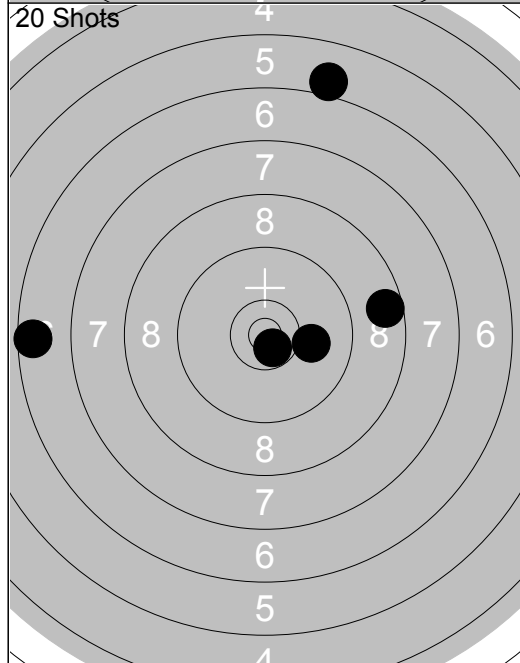

16:	6.0	↗
17:	6.6	↖
18:	*10.7	↘
19:	10.1	→
20:	8.6	→

Series	40.0
Total	183.0

<p>Sight</p>	<p>Sight</p>
--------------	--------------

<p>20 Shots</p>	<p>20 Shots</p>
-----------------	-----------------

<p>20 Shots</p>	<p>20 Shots</p>
-----------------	-----------------

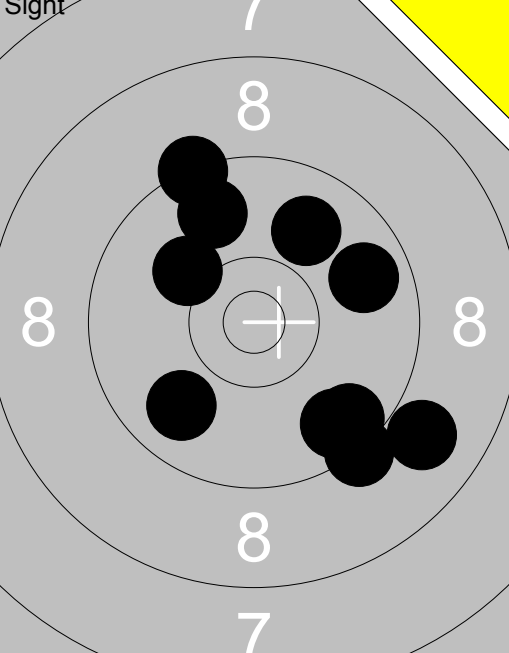
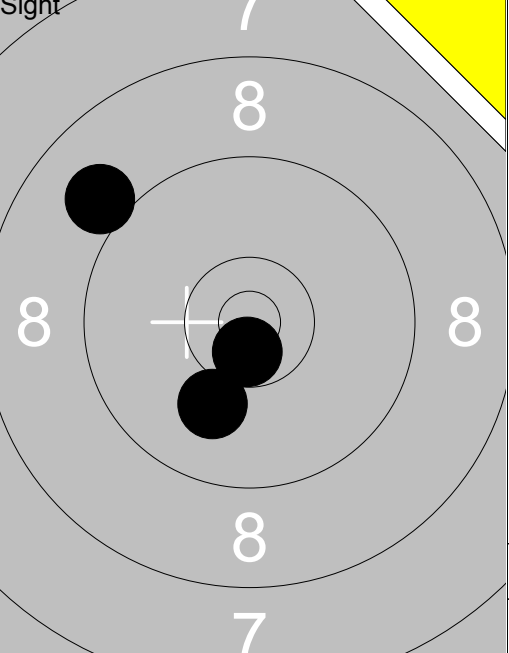
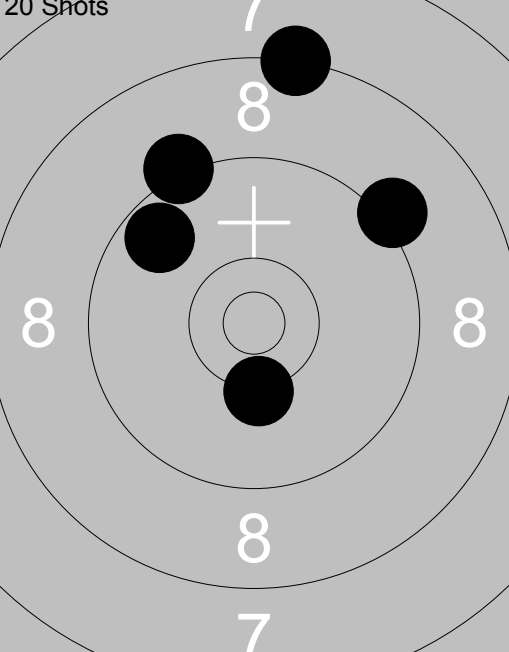
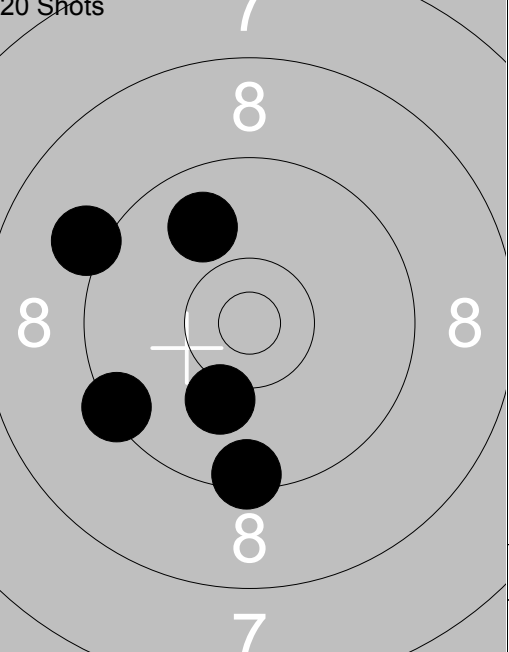
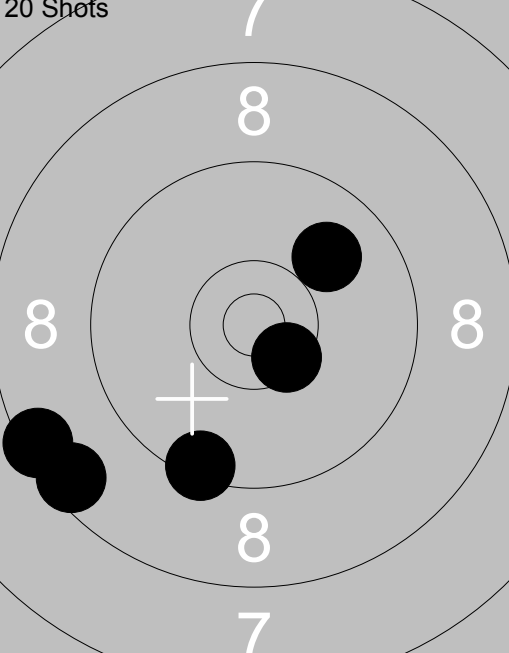
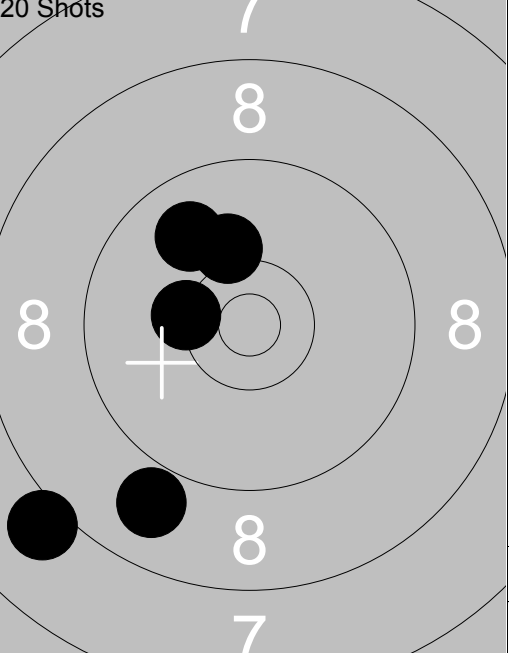
<p>Sight</p> 	<p>1: 9.3 ↘ 2: 9.9 ↗ 3: 9.3 ↗ 4: 9.8 → 5: 9.8 ↘ 6: 10.1 ↖ 7: 9.8 ↗ 8: 9.6 ↘ 9: 8.9 ↘ 10: 9.7 ↘</p> <p>Series 90.0 Total 0.0</p>	<p>Sight</p> 	<p>11: *10.7 ↘ 12: 10.1 ↘ 13: 9.0 ↖</p> <p>Series 29.0 Total 0.0</p>
<p>20 Shots</p> 	<p>1: 9.7 ↖ 2: 9.2 ↗ 3: 9.2 ↗ 4: 8.3 ↑ 5: 10.3 ↘</p> <p>Series 45.0 Total 45.0</p>	<p>20 Shots</p> 	<p>6: 9.4 ↘ 7: 10.1 ↘ 8: 9.9 ↗ 9: 9.4 ↖ 10: 9.1 ↖</p> <p>Series 46.0 Total 91.0</p>
<p>20 Shots</p> 	<p>11: 9.9 ↗ 12: *10.5 ↘ 13: 8.5 ↖ 14: 8.5 ↖ 15: 9.4 ↘</p> <p>Series 44.0 Total 135.0</p>	<p>20 Shots</p> 	<p>16: 8.1 ↖ 17: 9.9 ↗ 18: 10.2 ↗ 19: 8.9 ↘ 20: *10.3 ↖</p> <p>Series 45.0 Total 180.0</p>

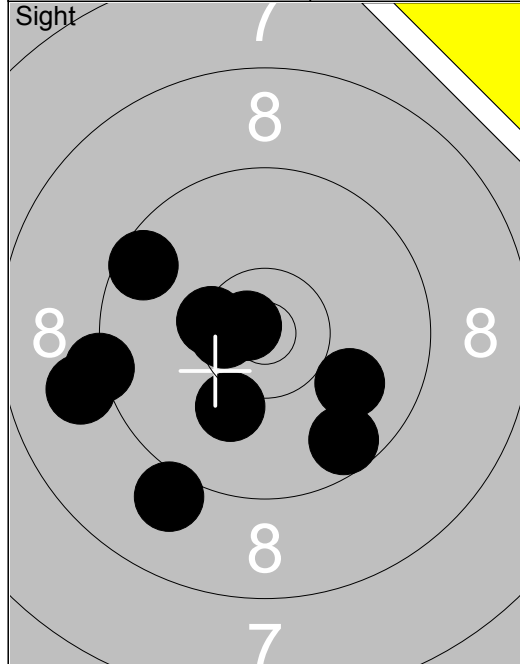

1: 9.3	←
2: 9.0	←
3: 9.6	↘
4: *10.5	←
5: 9.6	↖
6: *10.8	↖
7: 10.1	↘
8: *10.4	←
9: 9.1	↘
10: 10.0	↘
<b>Series</b>	<b>95.0</b>
<b>Total</b>	<b>0.0</b>

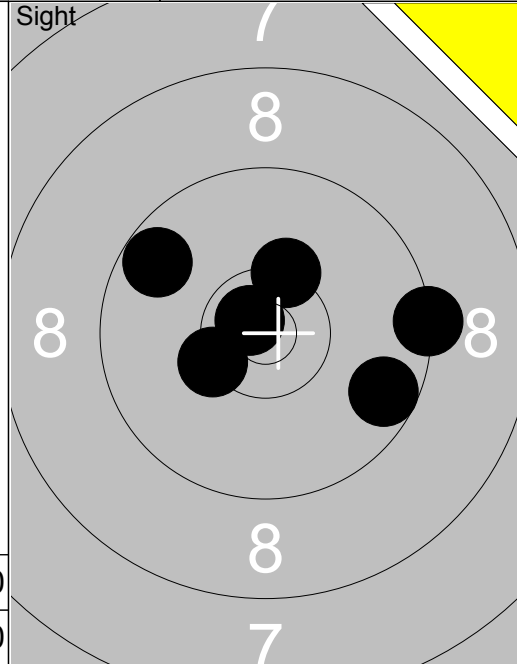

11: 9.7	↖
12: *10.7	↖
13: *10.3	↗
14: 9.3	→
15: *10.4	↖
16: 9.6	↘
<b>Series</b>	<b>57.0</b>
<b>Total</b>	<b>0.0</b>

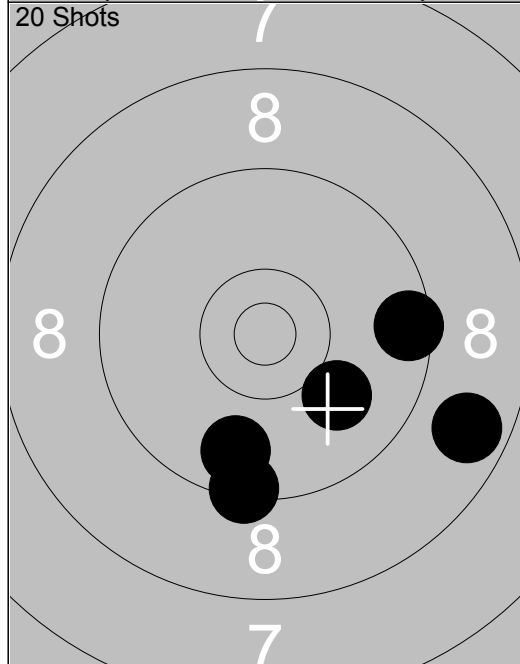

1: 9.5	→
2: 9.4	↓
3: 10.0	↘
4: 8.7	→
5: 9.8	↓
<b>Series</b>	<b>45.0</b>
<b>Total</b>	<b>45.0</b>

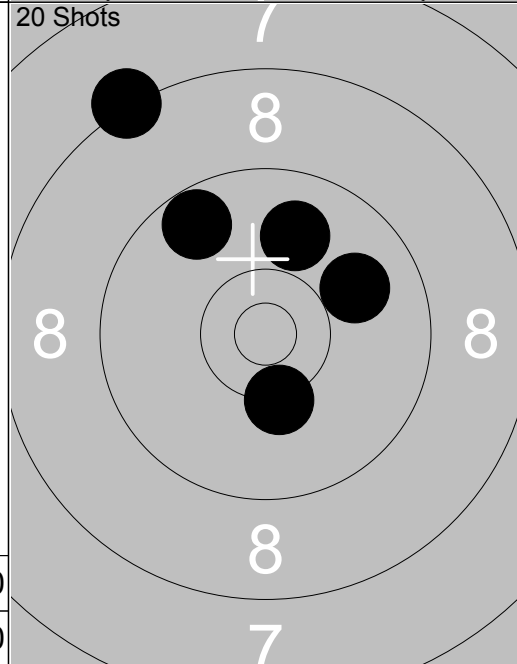

6: 9.9	↗
7: 9.9	↗
8: 10.3	↘
9: 8.3	↖
10: 9.7	↖
<b>Series</b>	<b>45.0</b>
<b>Total</b>	<b>90.0</b>

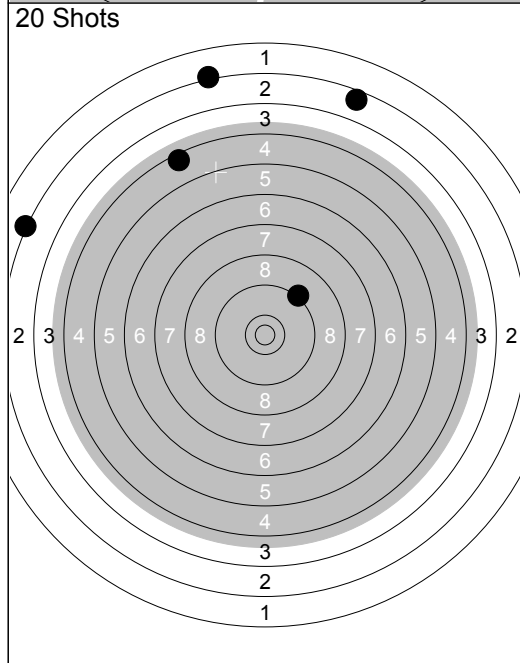

11: 2.2	↗
12: 2.6	↗
13: 9.3	↗
14: 2.2	←
15: 4.5	↖
<b>Series</b>	<b>19.0</b>
<b>Total</b>	<b>109.0</b>

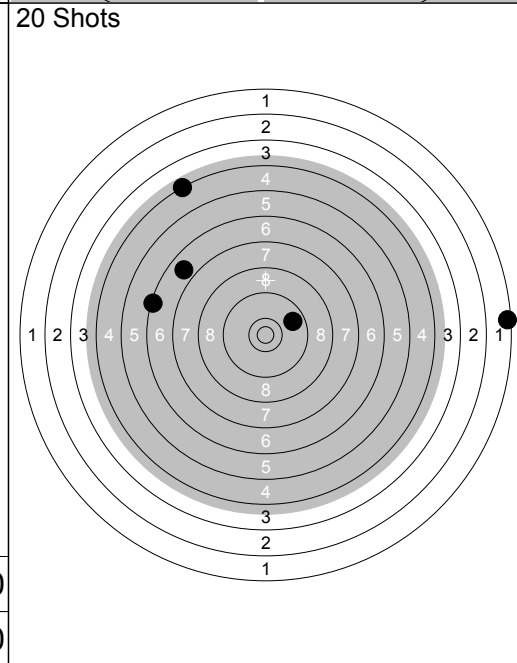

16: 9.7	↗
17: 6.9	↖
18: 1.5	→
19: 6.4	←
20: 4.3	↖
<b>Series</b>	<b>26.0</b>
<b>Total</b>	<b>135.0</b>

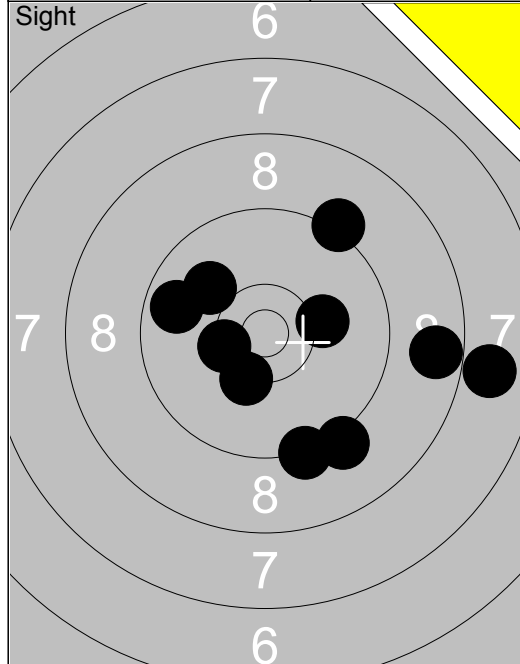

1: 9.3 ↓
2: *10.3 ↓
3: 10.0 ↖
4: 9.7 ←
5: *10.4 ↙
6: 9.2 ↓
7: 10.2 →
8: 8.7 →
9: 7.9 →
10: 9.2 ↗
Series 91.0
Total 0.0

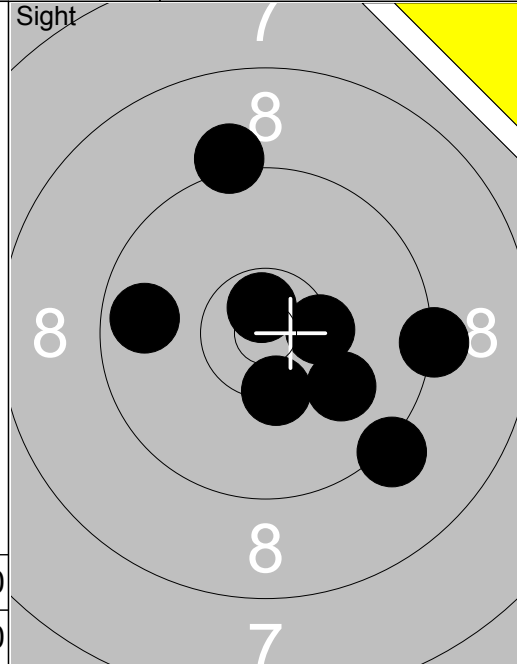

11: 9.3 →
12: *10.4 →
13: 9.2 ↓
14: *10.4 ↓
15: 10.0 →
16: 9.2 ↑
17: 9.7 ←
18: *10.7 ↑
Series 76.0
Total 0.0

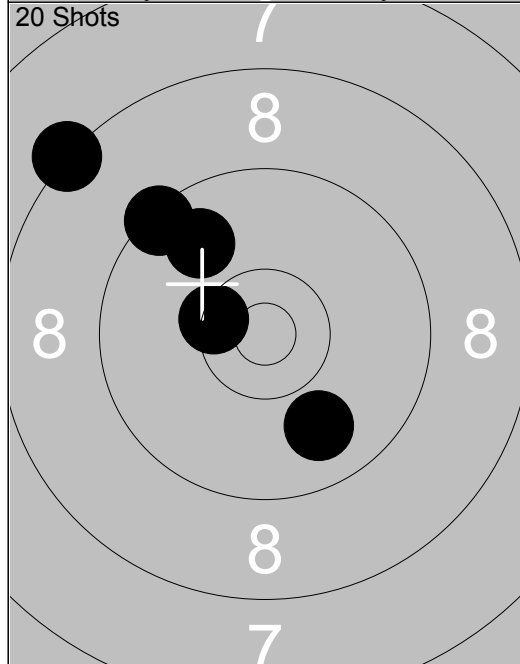

1: 9.4 ↗
2: *10.4 ↙
3: 9.8 ↗
4: 8.3 ↗
5: 9.9 ↓
Series 45.0
Total 45.0

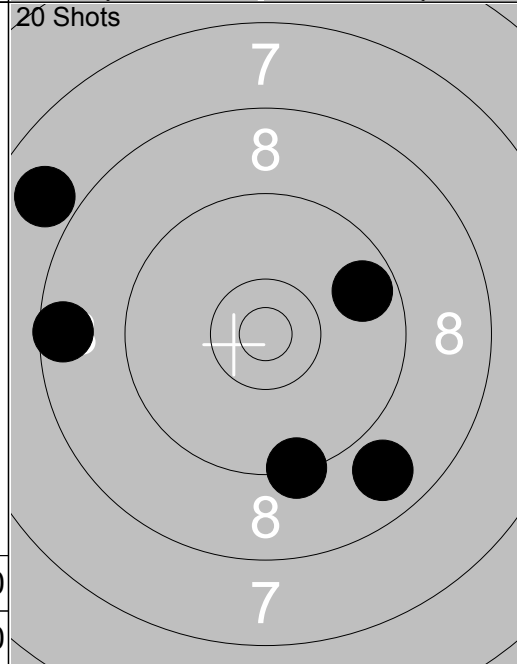

6: 8.8 ↓
7: 9.7 ↗
8: 9.3 ↓
9: 7.9 ←
10: 8.6 ←
Series 41.0
Total 86.0

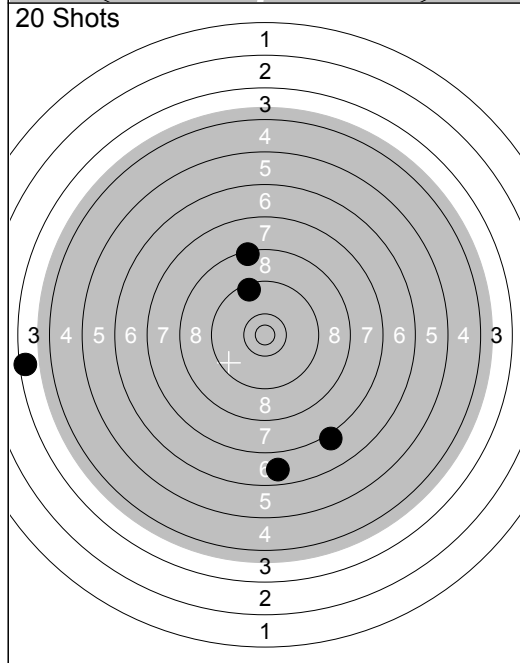

11: 6.8 ↓
12: 9.5 ↑
13: 3.5 ←
14: 8.4 ↑
15: 7.2 ↓
Series 33.0
Total 119.0

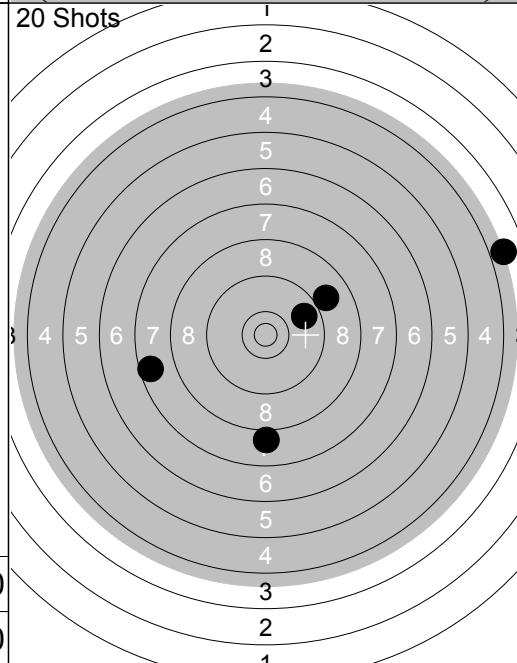

16: 3.9 →
17: 9.8 ↗
18: 8.0 ↓
19: 9.0 ↗
20: 7.6 ←
Series 36.0
Total 155.0

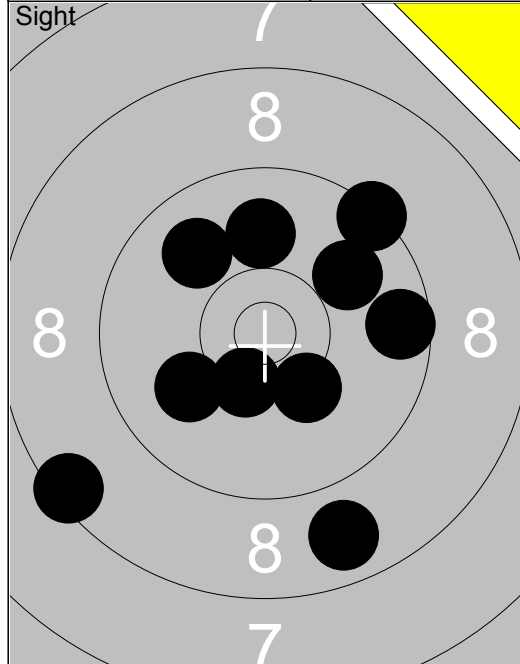

1:	8.8	↘
2:	8.5	↙
3:	9.9	↗
4:	*10.4	↘
5:	9.6	→
6:	9.9	↗
7:	10.3	↘
8:	10.0	↑
9:	9.4	↗
10:	10.0	↙
<b>Series</b>		<b>92.0</b>
<b>Total</b>		<b>0.0</b>

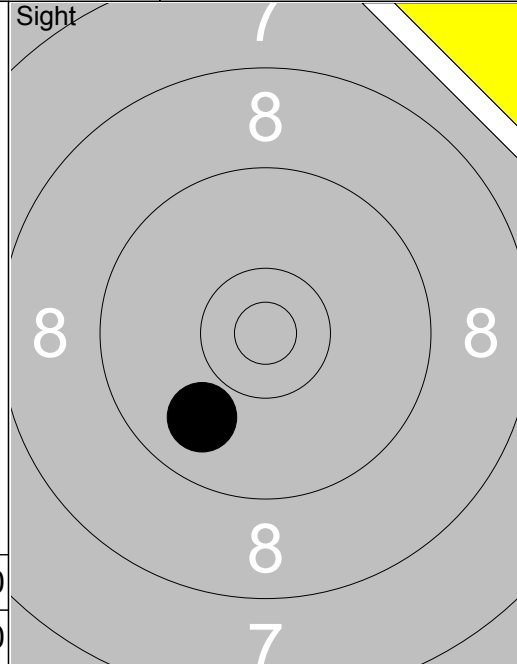

11:	9.9	↘
<b>Series</b>		<b>9.0</b>
<b>Total</b>		<b>0.0</b>

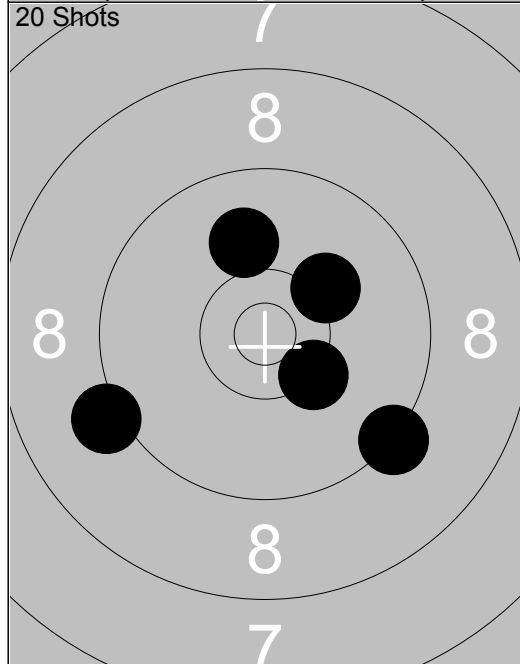

1:	9.2	↙
2:	10.0	↑
3:	*10.3	↘
4:	9.3	↘
5:	10.2	↗
<b>Series</b>		<b>48.0</b>
<b>Total</b>		<b>48.0</b>

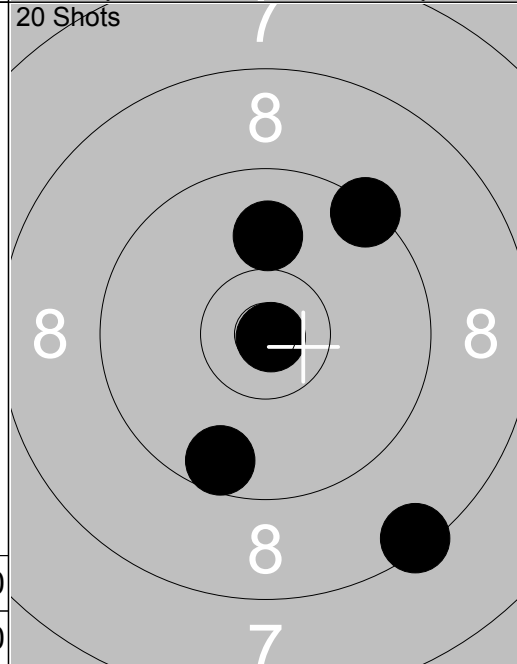

6:	10.0	↑
7:	9.4	↗
8:	8.4	↘
9:	*10.9	↘
10:	9.6	↘
<b>Series</b>		<b>46.0</b>
<b>Total</b>		<b>94.0</b>

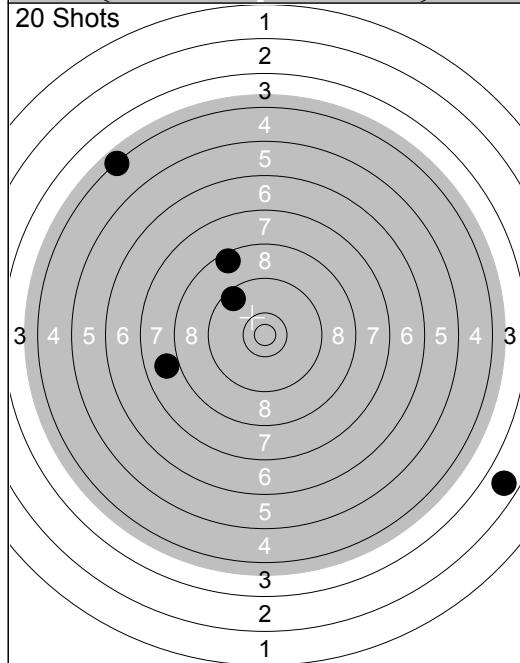

11:	7.9	↙
12:	8.5	↗
13:	9.5	↗
14:	4.3	↗
15:	2.7	↘
<b>Series</b>		<b>30.0</b>
<b>Total</b>		<b>124.0</b>

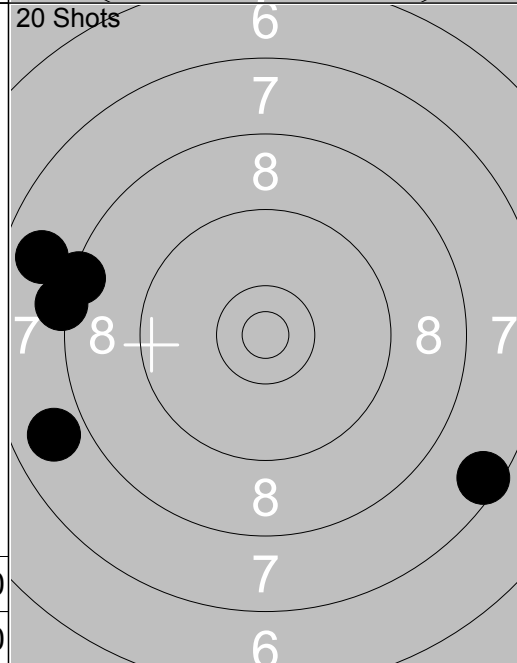

16:	8.4	↙
17:	7.5	↘
18:	7.8	↙
19:	7.9	↙
20:	8.2	↙
<b>Series</b>		<b>37.0</b>
<b>Total</b>		<b>161.0</b>



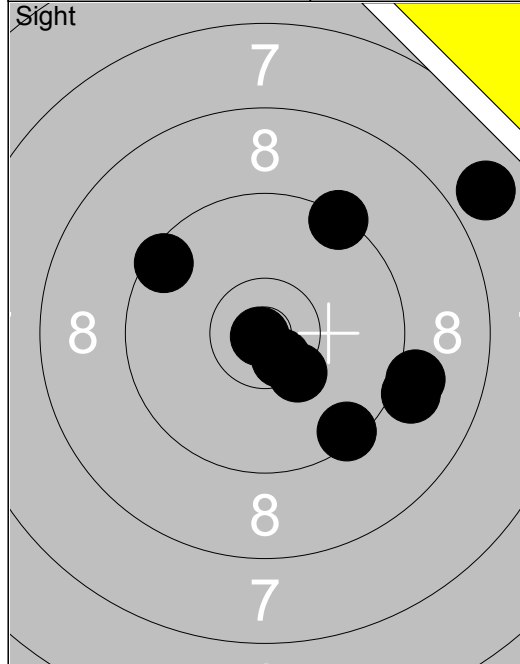

- 1: 7.9 ↗
- 2: 9.1 →
- 3: \*10.6 ↘
- 4: 9.5 ↖
- 5: \*10.9 ↘
- 6: 9.4 ↘
- 7: \*10.3 ↘
- 8: 9.4 ↗
- 9: 9.1 →

Series	82.0
Total	0.0

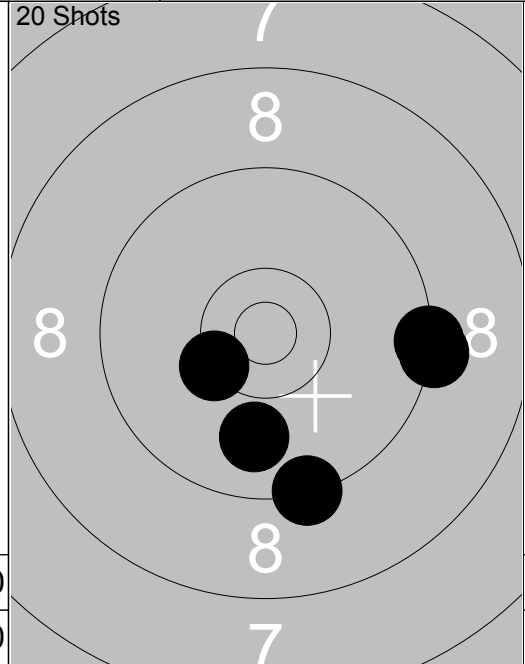

- 1: \*10.3 ↘
- 2: 9.3 →
- 3: 9.3 ↘
- 4: 9.9 ↘
- 5: 9.3 →

Series	46.0
Total	46.0

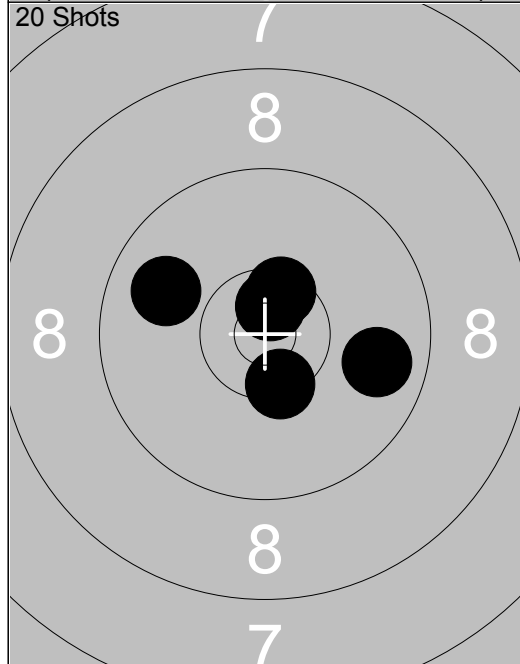

- 6: \*10.7 ↑
- 7: 9.8 →
- 8: \*10.5 ↑
- 9: \*10.4 ↘
- 10: 9.9 ↖

Series	48.0
Total	94.0

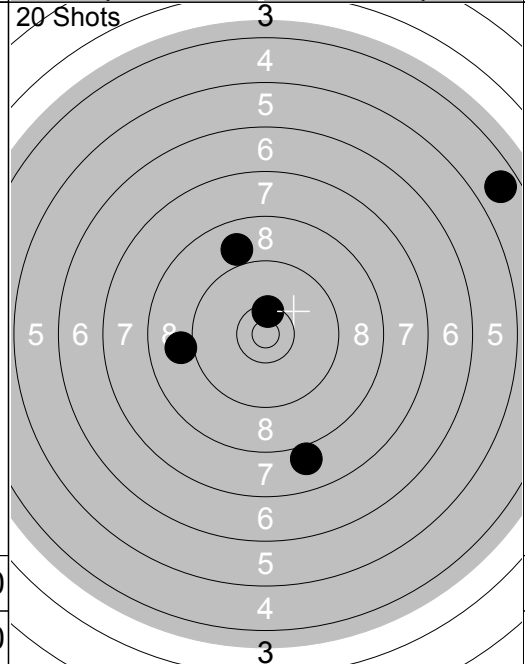

- 11: 4.7 ↗
- 12: 9.0 ←
- 13: 8.0 ↘
- 14: 8.9 ↖
- 15: \*10.4 ↑

Series	39.0
Total	133.0

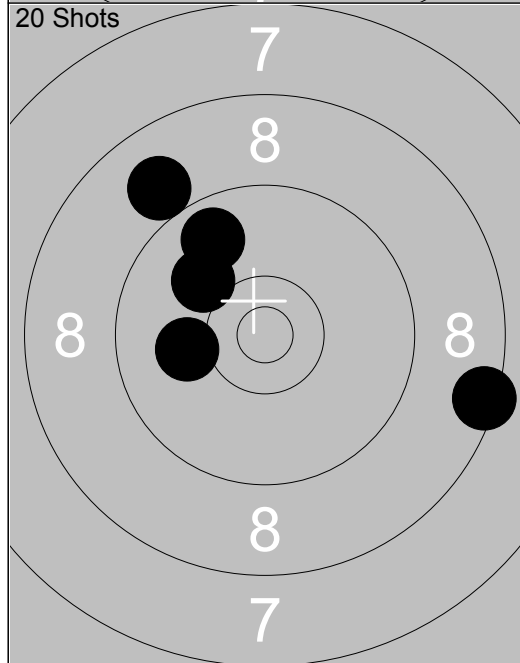

- 16: 9.0 ↖
- 17: 10.1 ←
- 18: 9.8 ↖
- 19: 10.0 ↖
- 20: 8.4 →

Series	46.0
Total	179.0



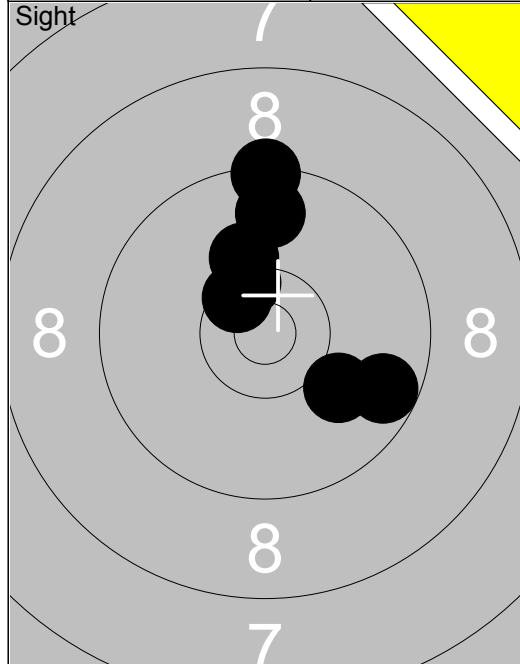

1:	9.8	↑
2:	9.4	↑
3:	*10.4	↖
4:	10.2	↑
5:	9.7	→
6:	*10.5	↖
7:	10.0	↘
Series	67.0	
Total	0.0	

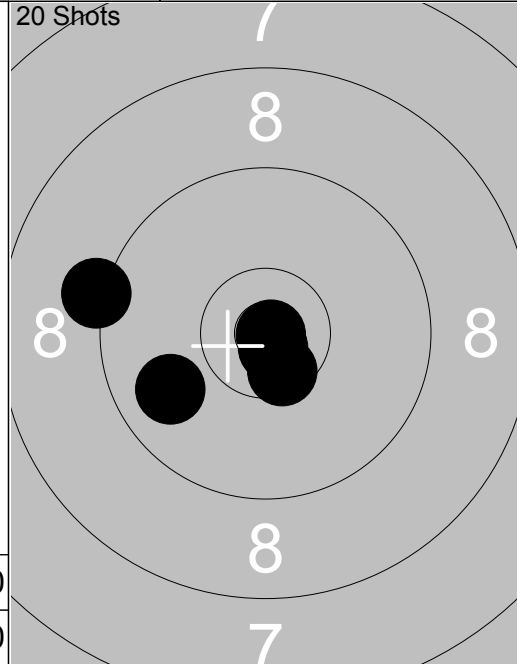

1:	9.2	←
2:	*10.9	→
3:	*10.5	↘
4:	*10.8	↘
5:	9.8	←
Series	48.0	
Total	48.0	

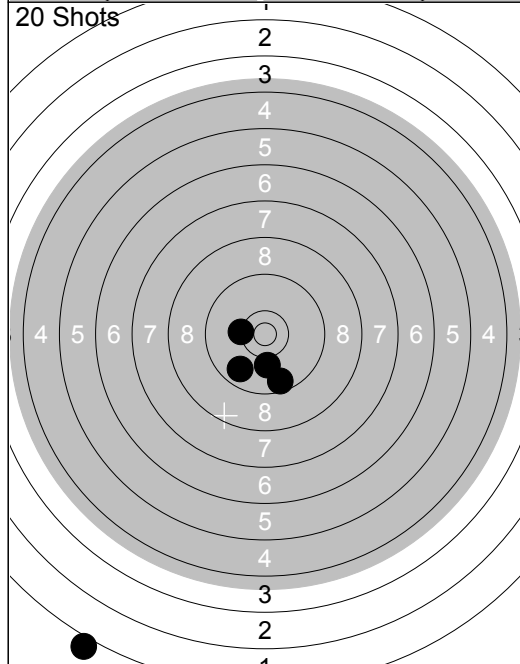

6:	1.0	↘
7:	9.6	↘
8:	9.8	↘
9:	10.3	←
10:	10.1	↓
Series	39.0	
Total	87.0	

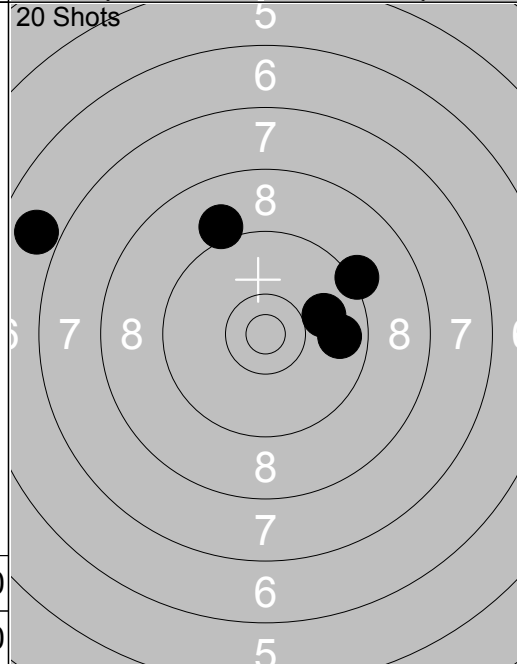

11:	9.1	↖
12:	9.2	↗
13:	10.0	→
14:	9.8	→
15:	6.9	←
Series	43.0	
Total	130.0	

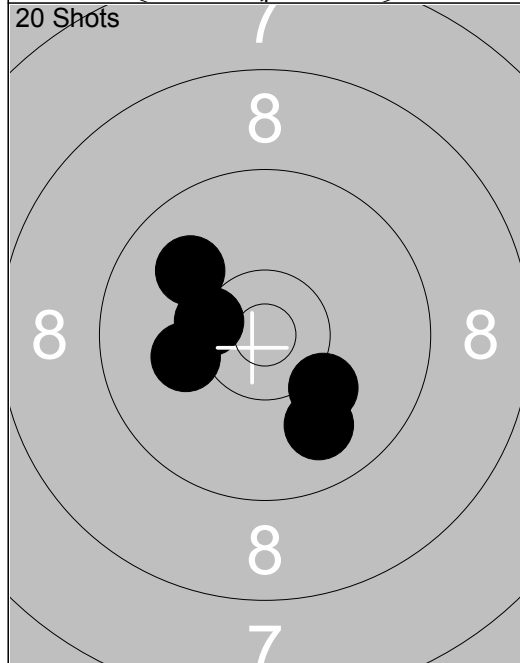

16:	*10.4	↖
17:	10.1	←
18:	10.0	↖
19:	9.9	↘
20:	10.2	↘
Series	49.0	
Total	179.0	

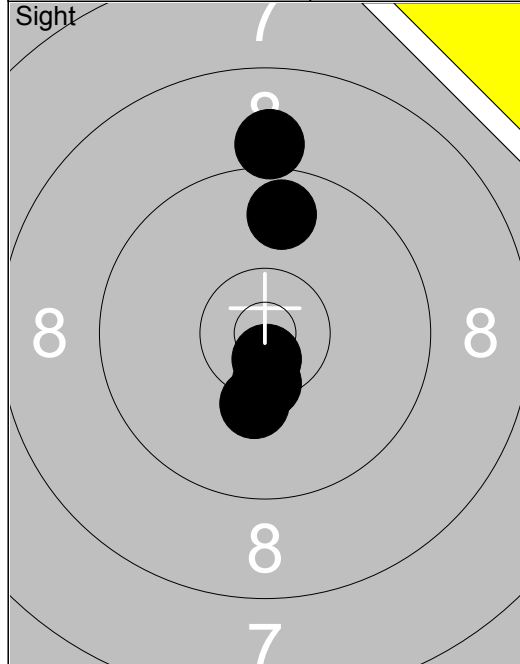

1: *10.7	↓
2: *10.5	↓
3: 9.1	↑
4: 10.2	↓
5: 9.8	↑
<b>Series 48.0</b>	
<b>Total 0.0</b>	

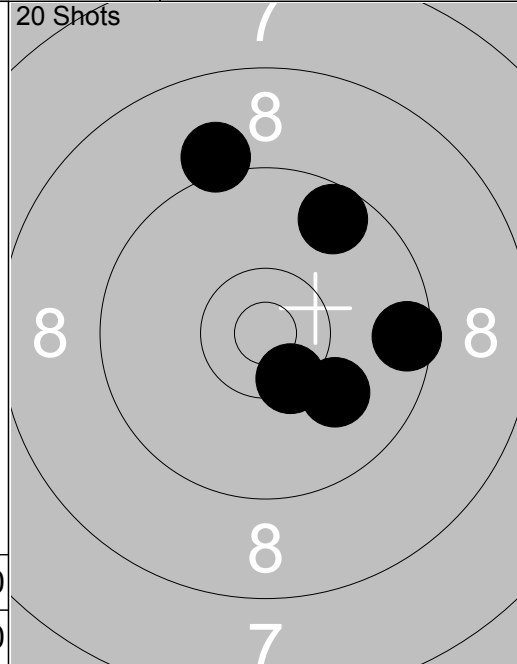

1: 9.6	↗
2: 9.1	↑
3: 10.0	↘
4: 9.5	→
5: *10.4	↘
<b>Series 47.0</b>	
<b>Total 47.0</b>	

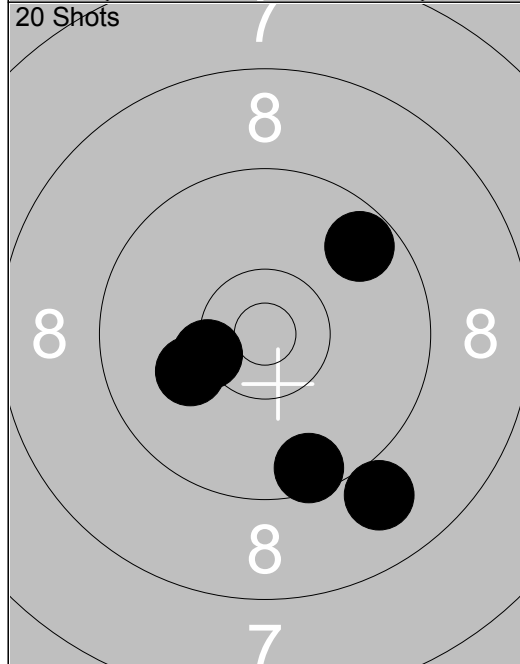

6: *10.3	↙
7: 10.1	↙
8: 9.5	↓
9: 9.7	↗
10: 9.0	↓
<b>Series 47.0</b>	
<b>Total 94.0</b>	

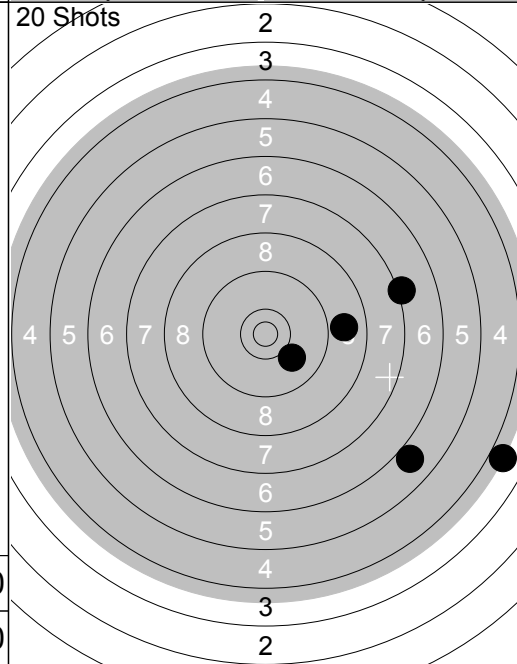

11: 3.9	↘
12: 8.9	→
13: 7.2	↗
14: 10.0	↘
15: 6.0	↘
<b>Series 34.0</b>	
<b>Total 128.0</b>	

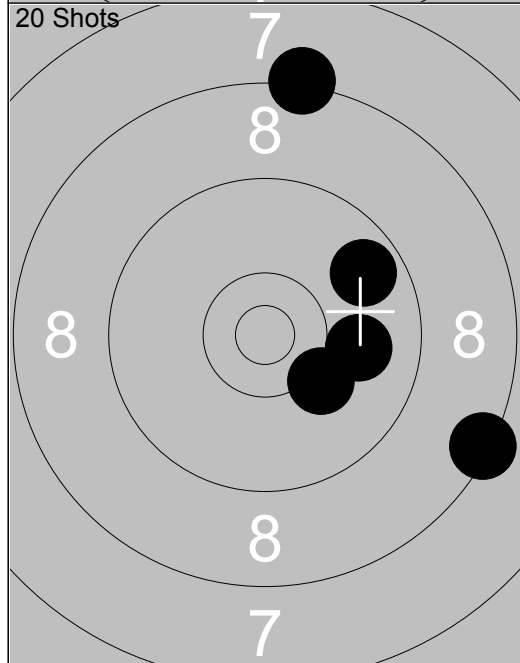

16: 10.0	→
17: 8.2	↑
18: 10.2	↘
19: 8.4	↘
20: 9.7	↗
<b>Series 45.0</b>	
<b>Total 173.0</b>	

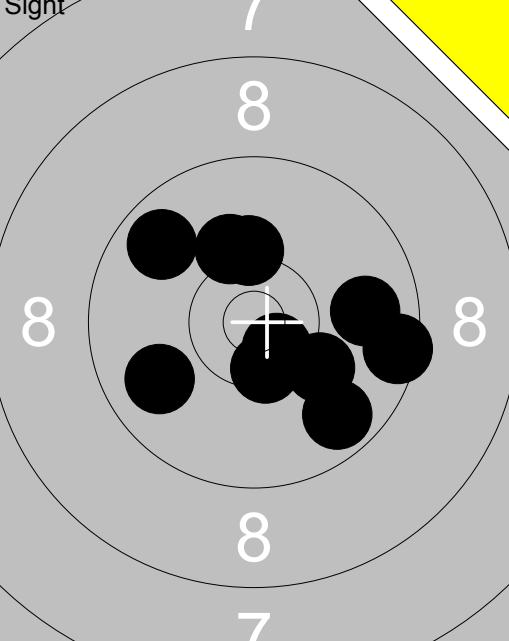
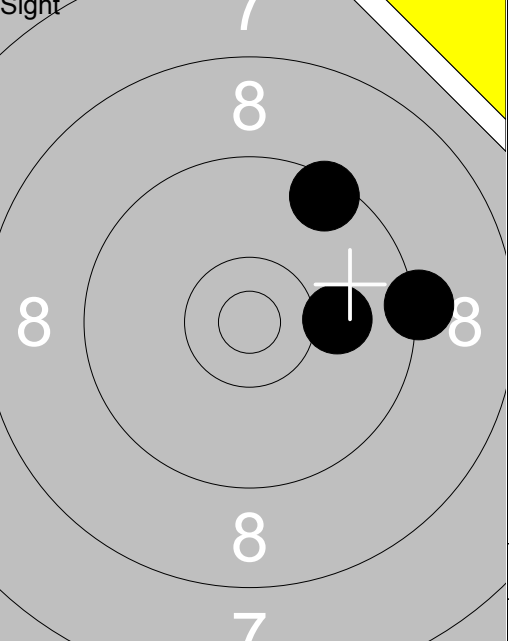
<p>Sight</p> 	<p>1: 9.7 ↖ 2: 9.9 ↙ 3: 9.7 ↘ 4: *10.6 ↘ 5: 10.2 ↑ 6: 10.1 ↘ 7: *10.5 ↘ 8: 9.8 → 9: 9.5 → 10: 10.2 ↑</p> <p>Series 95.0 Total 0.0</p>	<p>Sight</p> 	<p>11: 9.5 ↗ 12: 9.3 → 13: 10.1 →</p> <p>Series 28.0 Total 0.0</p>
---	---	---	--

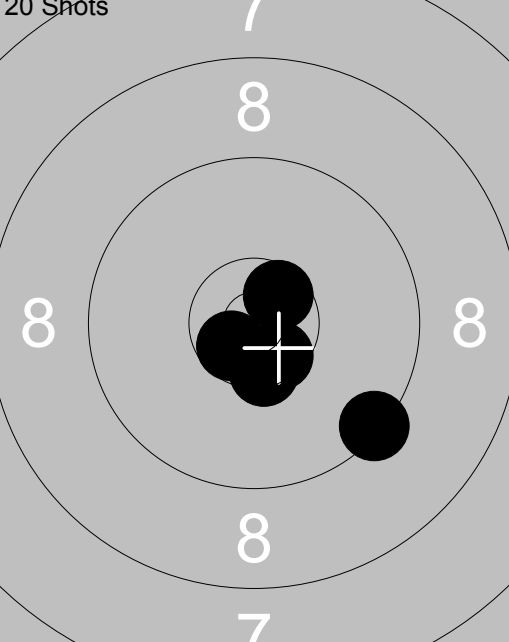
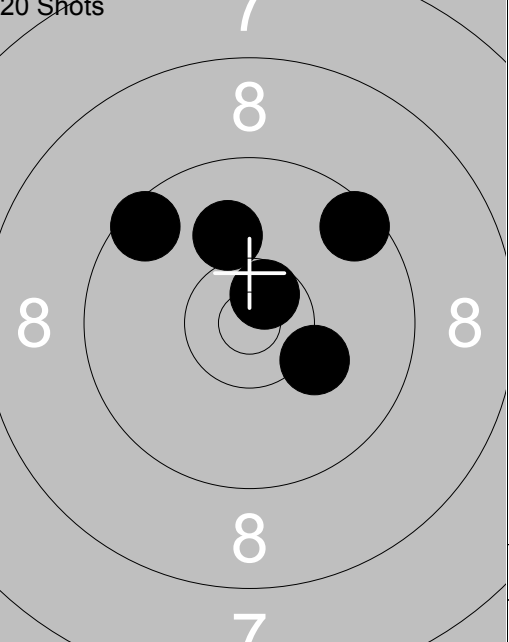
<p>20 Shots</p> 	<p>1: *10.5 ↘ 2: 9.4 ↘ 3: *10.6 ↘ 4: *10.5 ↘ 5: *10.6 ↗</p> <p>Series 49.0 Total 49.0</p>	<p>20 Shots</p> 	<p>6: 9.5 ↗ 7: 10.0 ↑ 8: 9.5 ↘ 9: *10.6 ↗ 10: 10.2 ↘</p> <p>Series 48.0 Total 97.0</p>
---	---	---	--

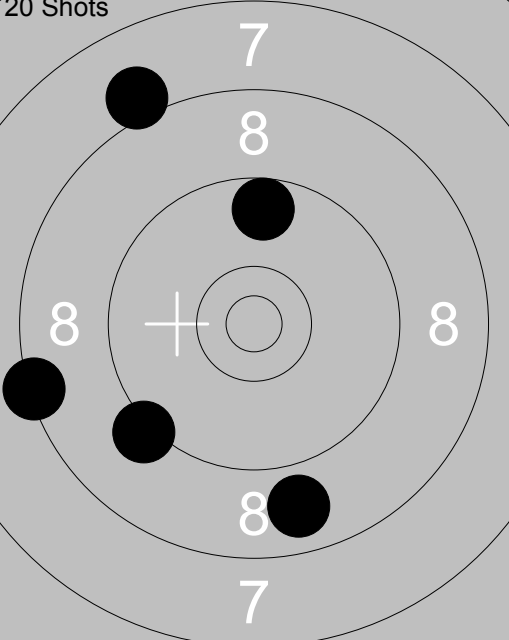
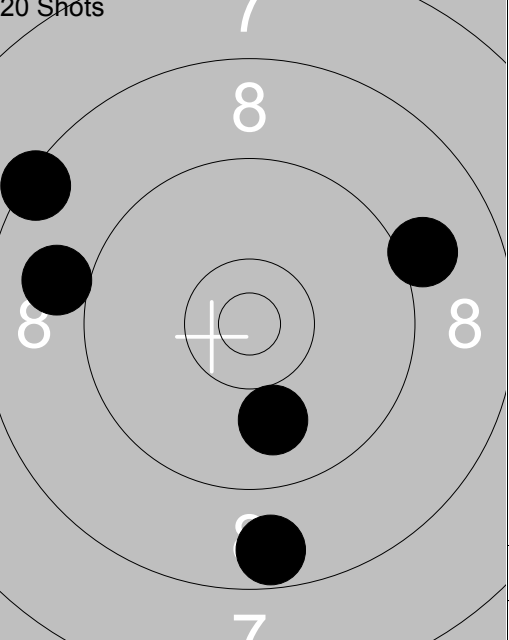
<p>20 Shots</p> 	<p>11: 8.4 ← 12: 8.8 ↓ 13: 9.2 ↙ 14: 8.1 ↗ 15: 9.6 ↑</p> <p>Series 42.0 Total 139.0</p>	<p>20 Shots</p> 	<p>16: 9.0 ← 17: 8.4 ↘ 18: 8.7 ↓ 19: 9.1 → 20: 10.0 ↓</p> <p>Series 44.0 Total 183.0</p>
--	---	--	--

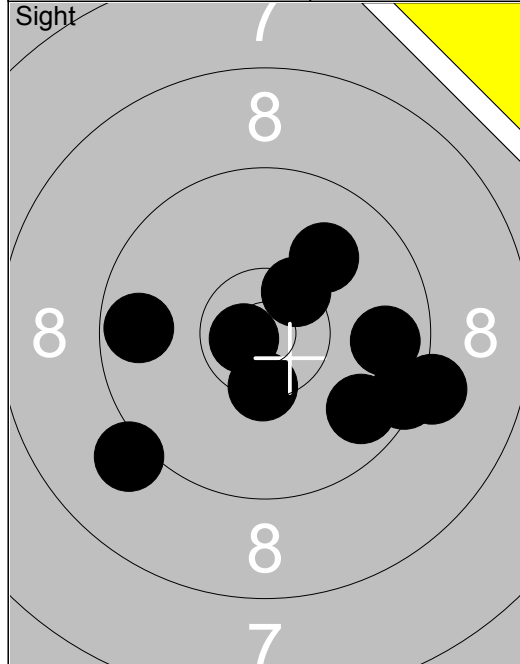

1:	9.4	➤
2:	9.7	➔
3:	9.2	➤
4:	9.7	➤
5:	9.7	➤
6:	10.0	↗
7:	9.1	↙
8:	*10.7	↙
9:	*10.4	↗
10:	*10.4	⬇
Series		94.0
Total		0.0

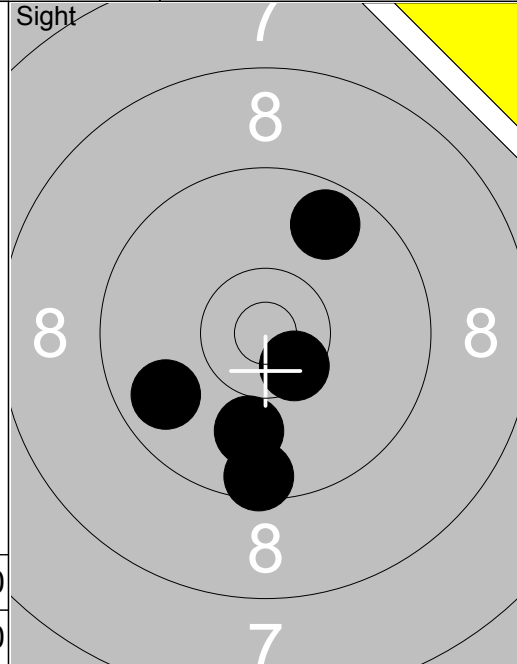

11:	9.5	⬇
12:	9.7	↗
13:	9.8	↙
14:	10.0	⬇
15:	*10.5	⬇
Series		47.0
Total		0.0

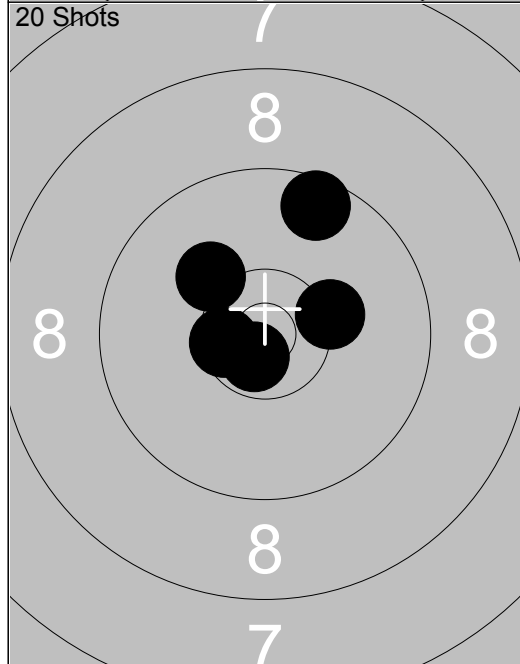

1:	10.2	↖
2:	10.3	➔
3:	*10.5	↙
4:	*10.7	⬇
5:	9.6	↗
Series		49.0
Total		49.0

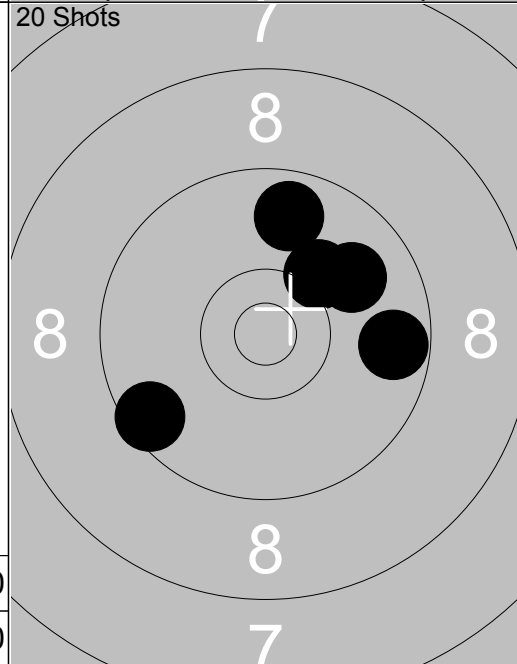

6:	9.5	↙
7:	9.8	↗
8:	10.2	↗
9:	9.7	➔
10:	9.9	↗
Series		46.0
Total		95.0

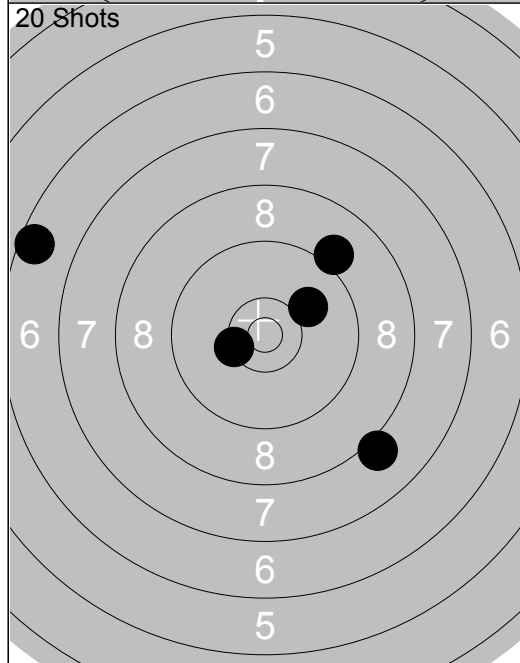

11:	8.1	⬇
12:	6.6	↙
13:	*10.4	↙
14:	9.1	↗
15:	10.0	↗
Series		43.0
Total		138.0

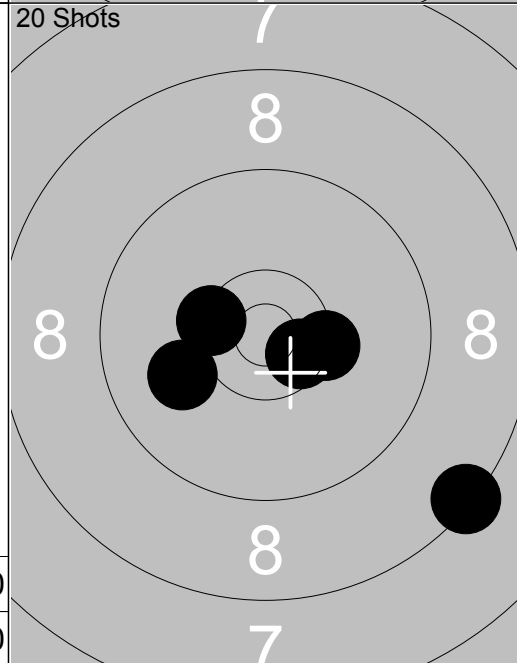

16:	*10.6	↘
17:	8.4	⬇
18:	*10.4	↙
19:	10.0	↙
20:	*10.3	➔
Series		48.0
Total		186.0

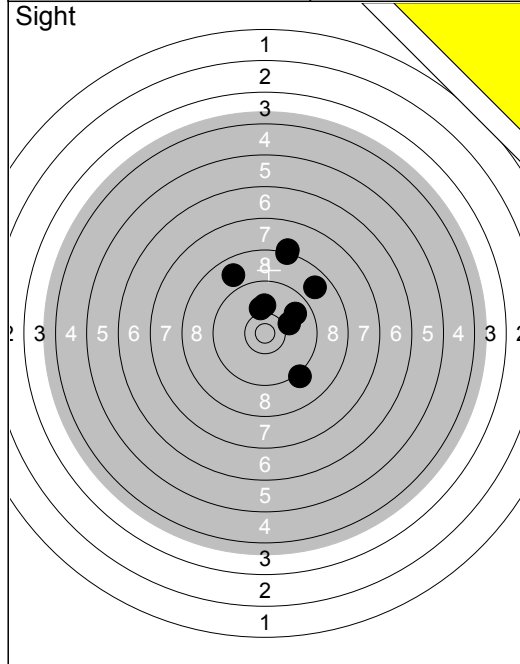

1:	0.0	↑
2:	8.3	↑
3:	8.8	↖
4:	8.8	↗
5:	10.1	↑
6:	10.1	→
7:	9.8	↗
8:	8.2	↑
9:	10.1	↑
10:	9.2	↘
<b>Series</b>		<b>80.0</b>
<b>Total</b>		<b>0.0</b>

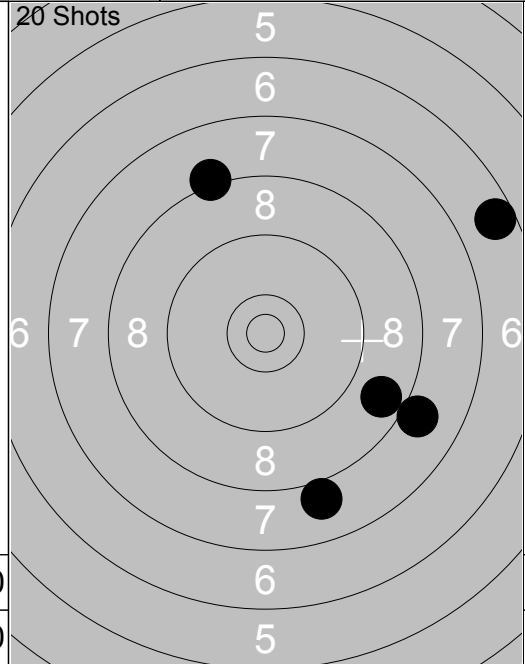

1:	8.7	↘
2:	8.0	↘
3:	8.0	↓
4:	6.6	↗
5:	8.2	↑
<b>Series</b>		<b>38.0</b>
<b>Total</b>		<b>38.0</b>

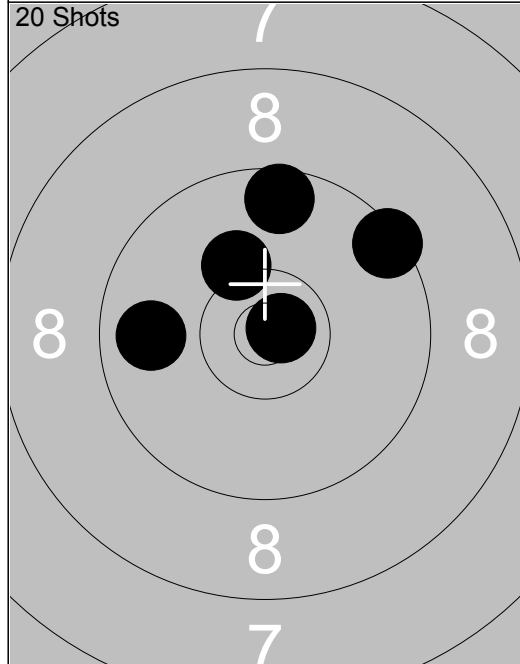

6:	10.2	↖
7:	9.8	←
8:	*10.8	→
9:	9.4	↗
10:	9.6	↑
<b>Series</b>		<b>47.0</b>
<b>Total</b>		<b>85.0</b>

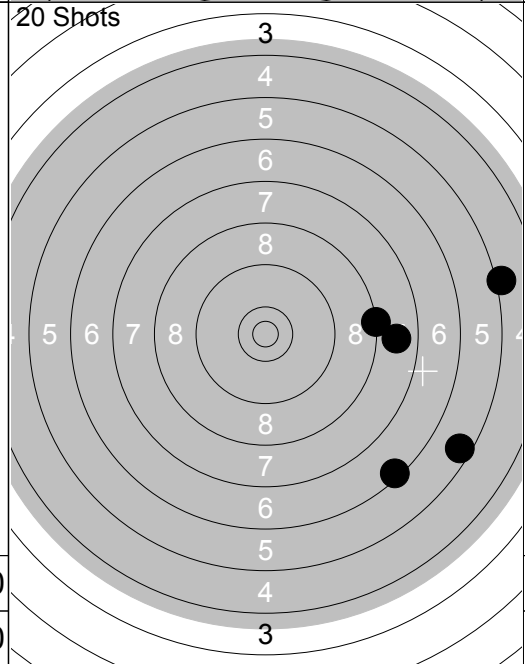

11:	5.6	↘
12:	8.3	→
13:	6.4	↓
14:	5.2	→
15:	7.8	→
<b>Series</b>		<b>31.0</b>
<b>Total</b>		<b>116.0</b>

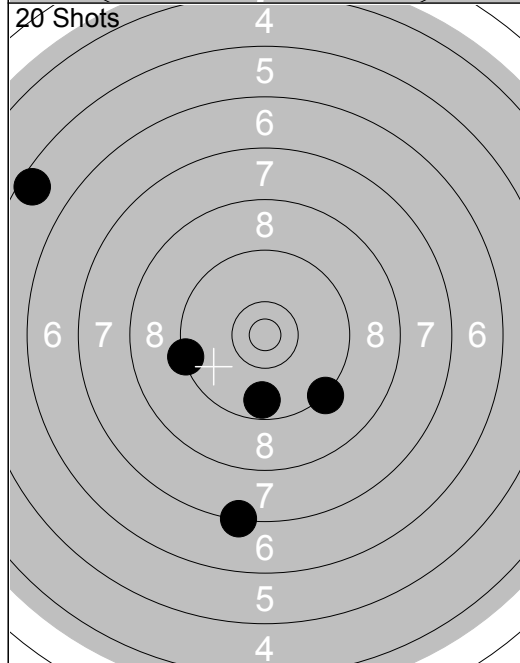

16:	5.6	↖
17:	9.3	↘
18:	7.3	↓
19:	9.3	←
20:	9.7	↓
<b>Series</b>		<b>39.0</b>
<b>Total</b>		<b>155.0</b>