

1: 8.5 ←	6: *10.3↑						
2: 9.5 ←		Serie	57.0	1: *10.7→		Serie	50.0
3: 10.0 ↗				2: *10.4↓			
4: 10.3 →		Total	194.0	3: *10.8↘		Total	244.0
5: 10.0 ←				4: *10.6↙			
				5: *10.7↗			

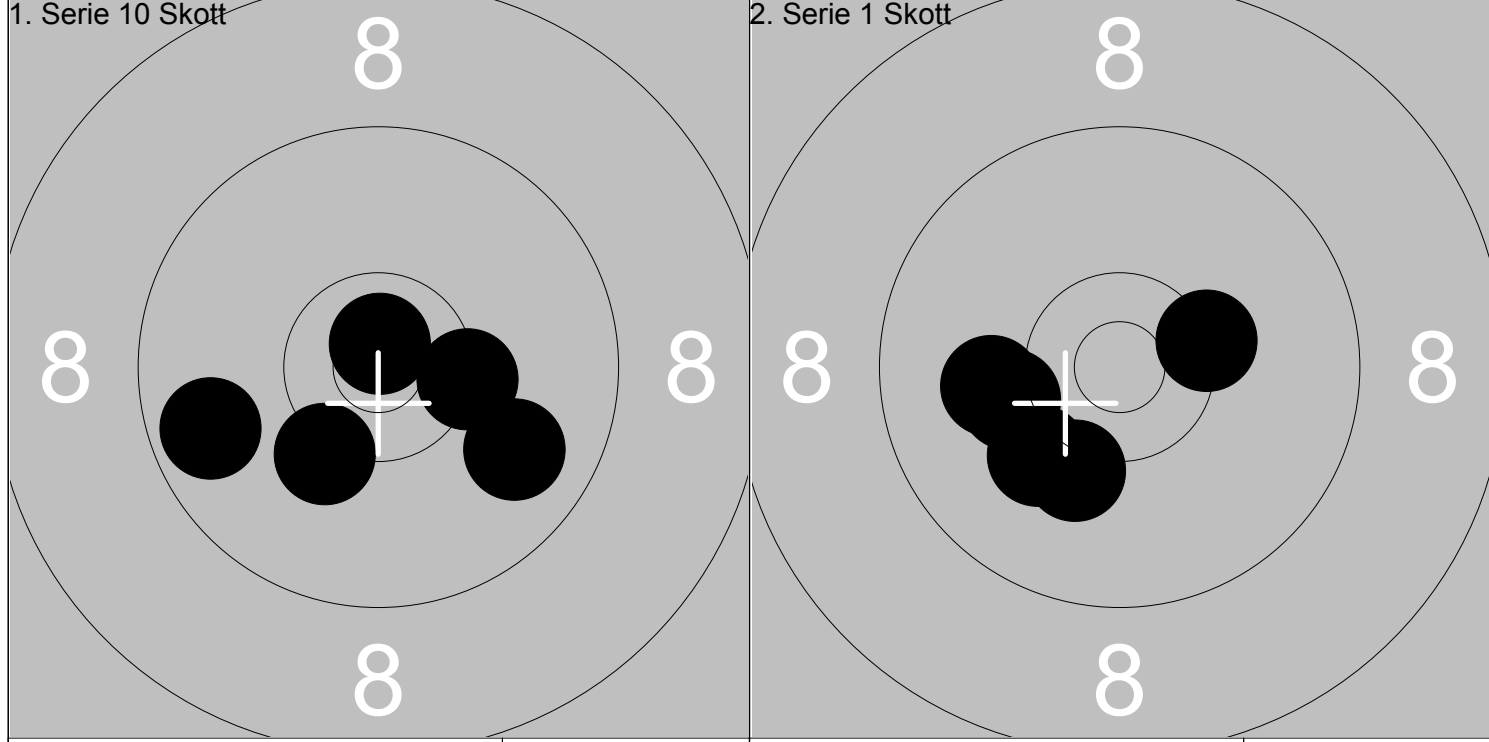

6: *10.3→							
7: *10.8↑		Serie	48.0	1: *10.3→		Serie	50.0
8: 9.9 ↘				2: 10.1 ←			
9: 10.2 ↓		Total	292.0	3: 10.1 ↓		Total	342.0
10: 9.7 ←				4: 10.2 ↓			
				5: 10.2 ←			

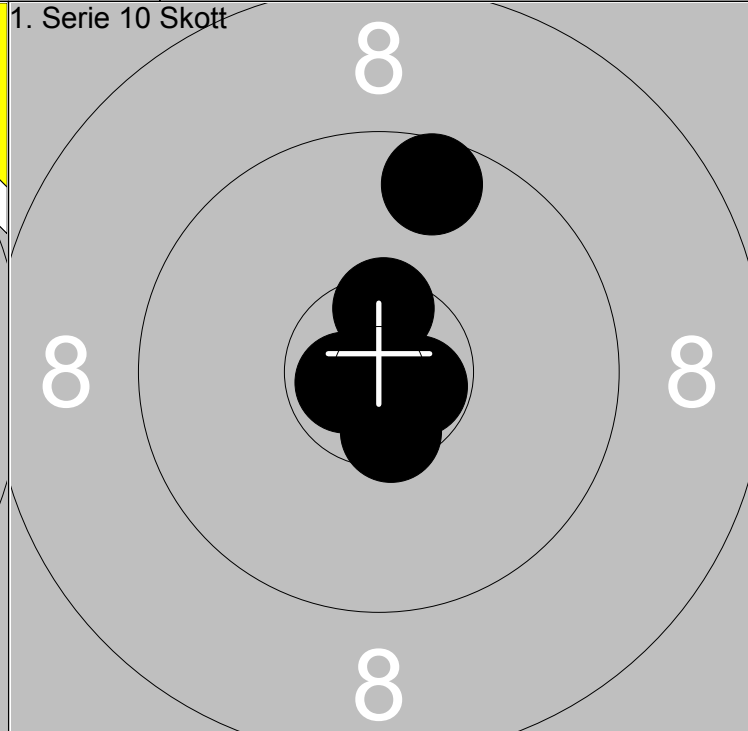
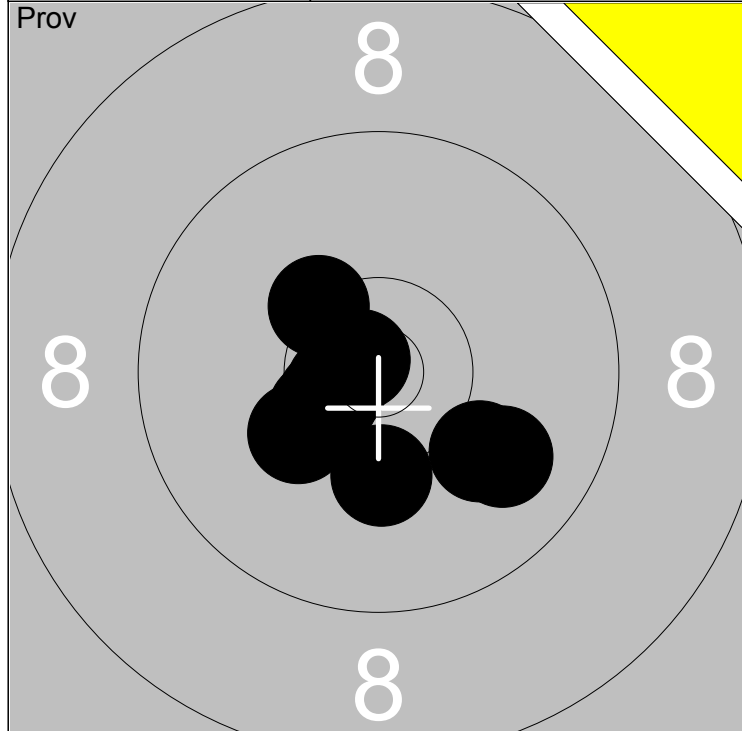

1: 10.2 ↓	6: 10.3 ↙	Serie	89.0
2: *10.5 ↙	7: *10.7 ↙		
3: *10.3 ↖	8: *10.6 ↙	Total	193.0
4: 9.9 ↘	9: *10.8 ↖		
5: 10.1 ↘			

1: 9.6 ↑	Serie	49.0
2: *10.7 →		
3: *10.5 ↓	Total	242.0
4: *10.5 ↑		
5: *10.7 ↙		

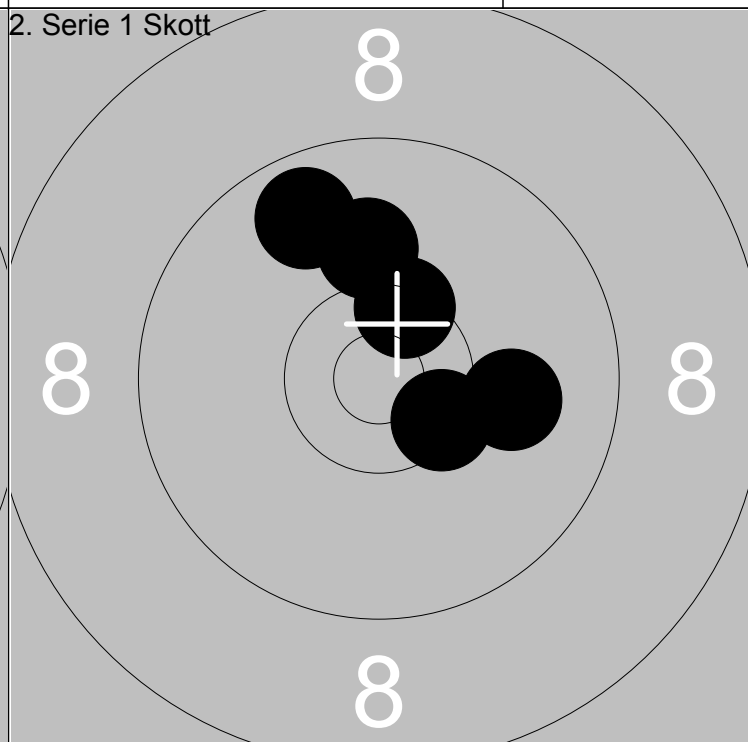
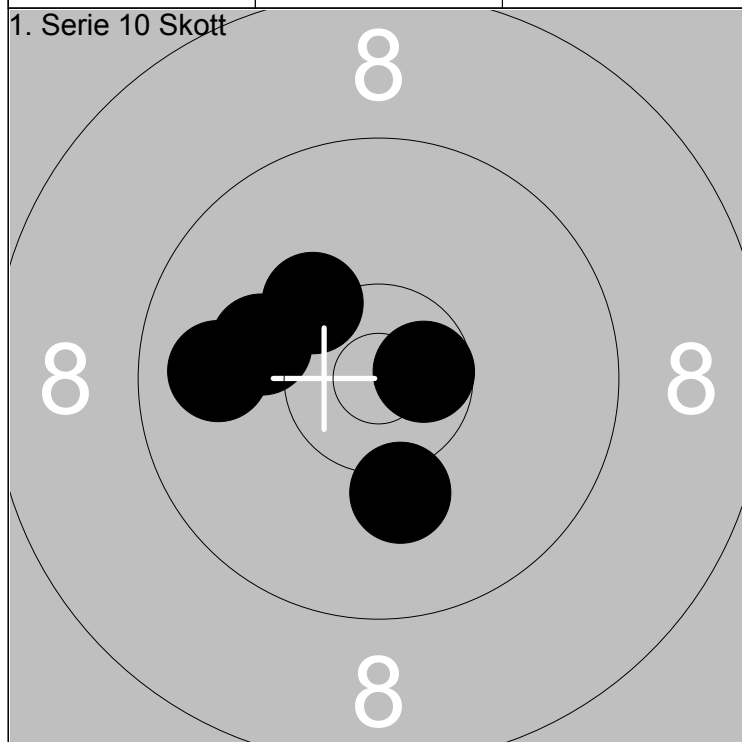

6: 9.8 ←	Serie	49.0
7: 10.3 ↗		
8: 10.1 ←	Total	291.0
9: *10.6 →		
10: 10.2 ↓		

1: *10.4 →	Serie	49.0
2: 9.7 ↑		
3: 10.0 →	Total	340.0
4: 10.1 ↑		
5: *10.4 ↑		

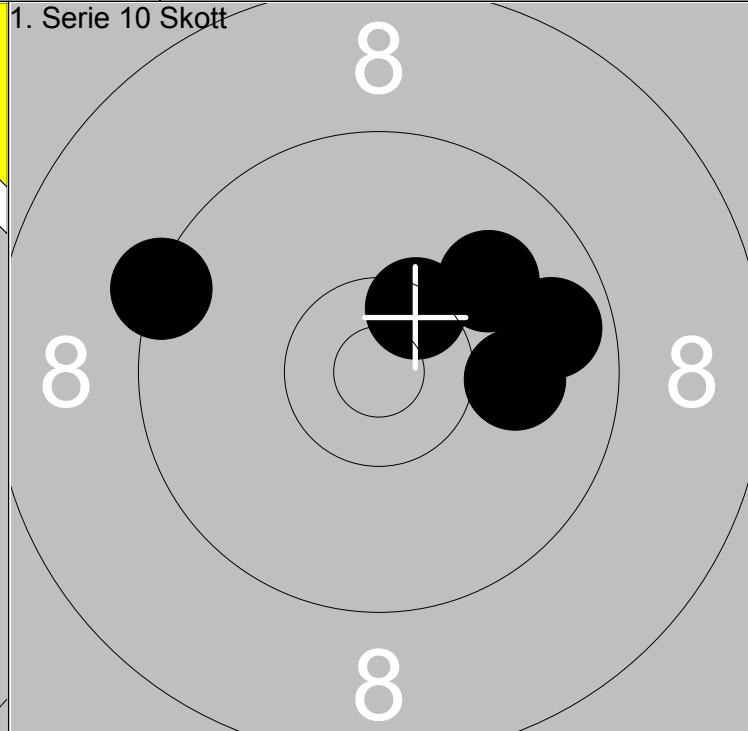
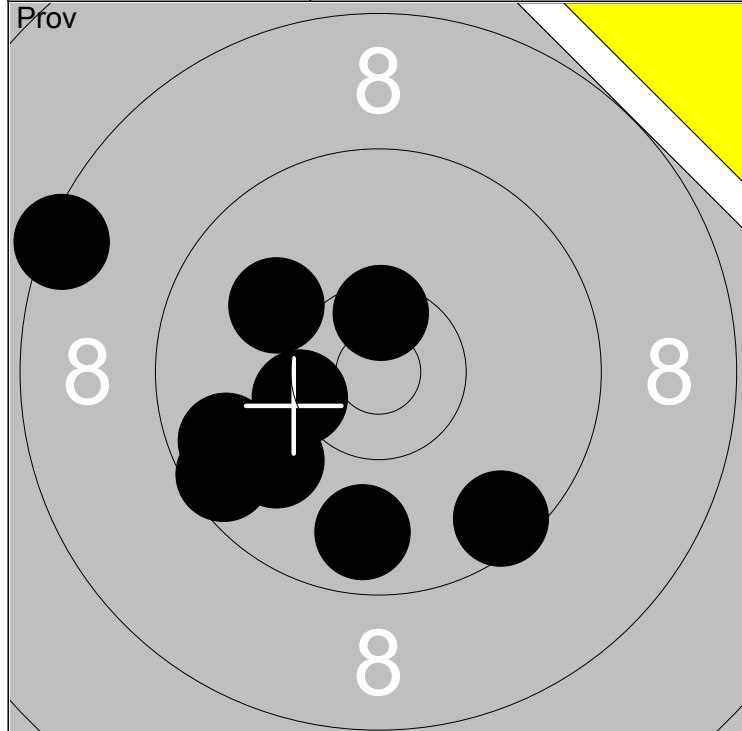

1: 8.4 ↙	6: 9.6 ↙	Serie	83.0
2: *10.5↑	7: 9.8 ↓		
3: 9.9 ↙	8: 9.7 ↙	Total	192.0
4: 9.5 ↘	9: 10.0 ↖		
5: *10.3↙			

1: 9.7 →	Serie	48.0
2: 10.0 ↗		
3: 10.0 →	Total	240.0
4: 9.3 ↙		
5: *10.4↗		

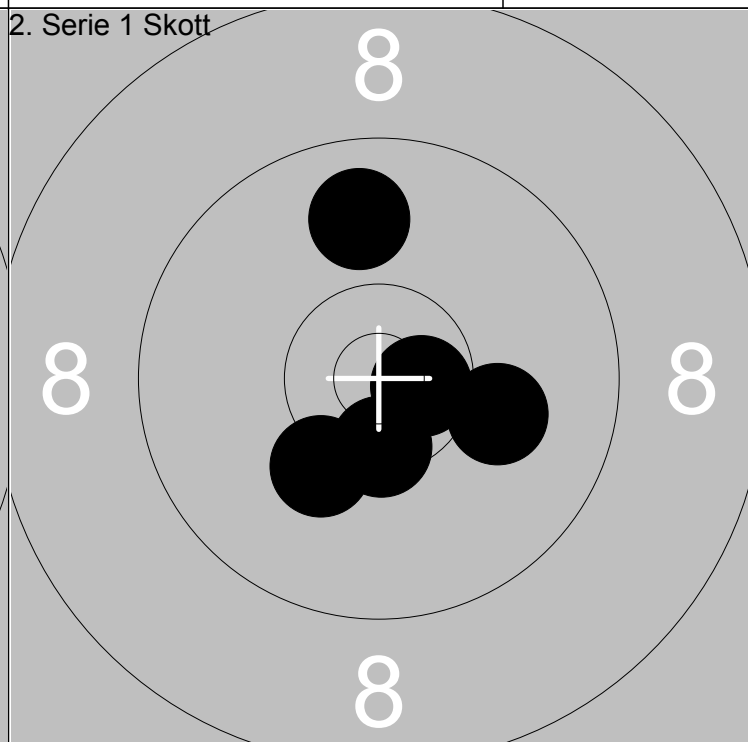
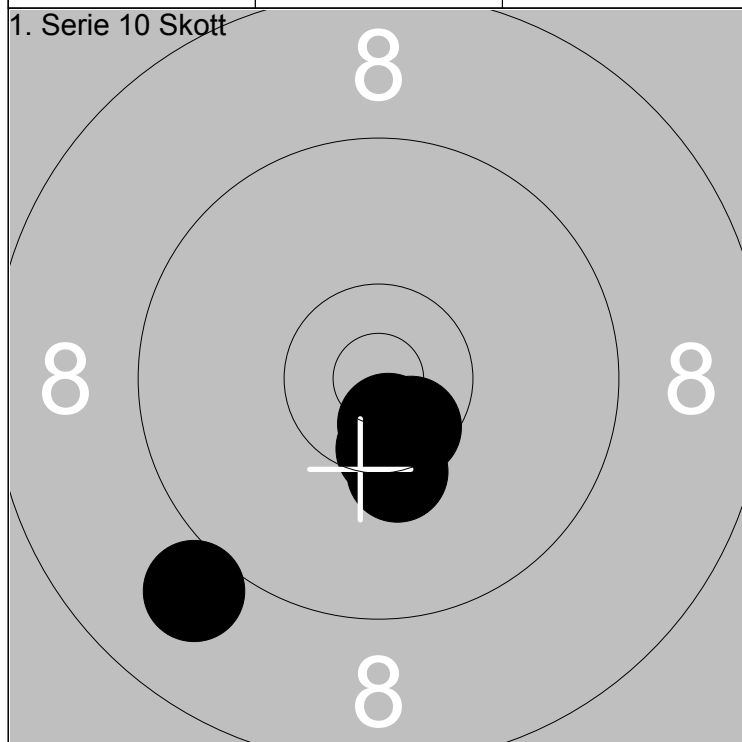

6: *10.3↓	Serie	49.0
7: 9.0 ↙		
8: *10.5↓	Total	289.0
9: *10.6↓		
10: *10.6↓		

1: 10.1 →	Serie	49.0
2: 10.2 ↙		
3: *10.7→	Total	338.0
4: 9.8 ↑		
5: *10.5↓		

Skjutlag 3	Tavla 4	Stefan Thorin		
----------------------	-------------------	----------------------	--	--

50m	Umeå	3	Vb
-----	------	---	----

2014-08-30	Höstträffen 2014	Ramselefors SKF
------------	------------------	-----------------

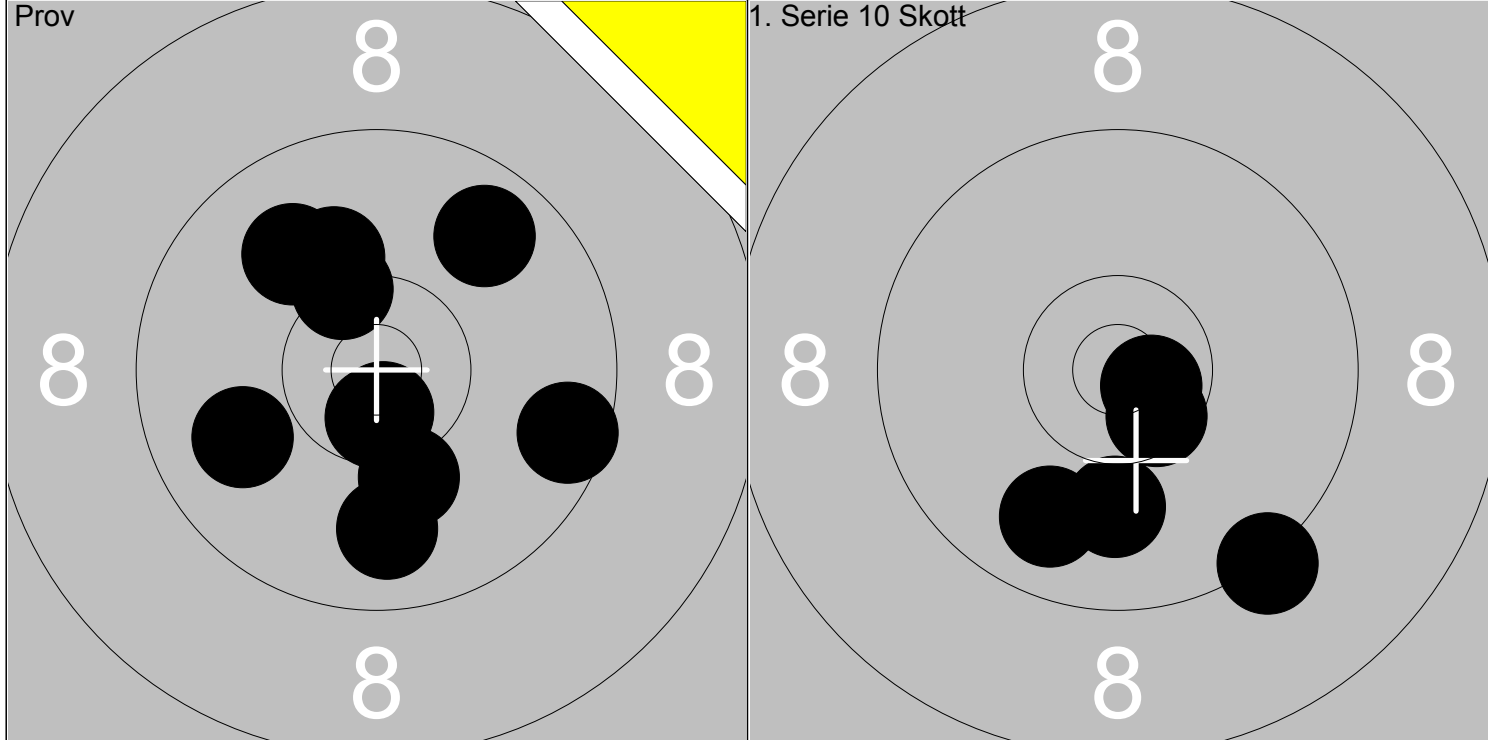

1: 10.0 ↖	6: *10.6 ↓	Serie 96.0	1: 9.8 ↙	Serie 48.0
2: *10.3 ↗	7: 9.9 ↓		2: 9.3 ↘	
3: 10.2 ↓	8: 9.8 ↗	Total 191.0	3: 10.0 ↓	Total 239.0
4: *10.7 ↓	9: 10.1 ↗		4: *10.7 →	
5: 9.9 ↙	10: 9.6 →		5: *10.5 ↘	

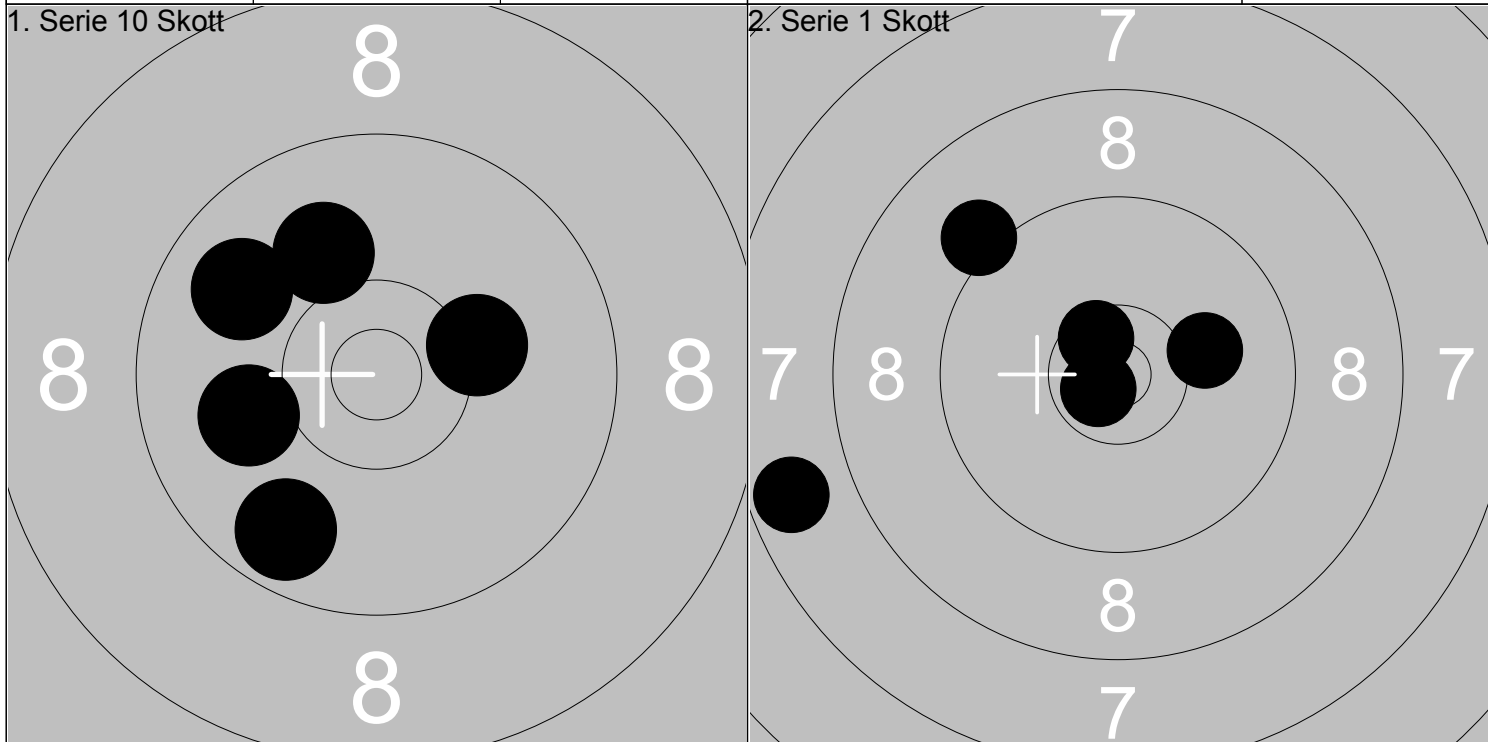

6: 9.9 ↙	Serie 48.0	1: *10.6 ↗	Serie 46.0
7: 10.0 ↙		2: 9.1 ↖	
8: 10.2 →	Total 287.0	3: 7.7 ↙	Total 333.0
9: 9.7 ↙		4: 10.1 →	
10: 10.0 ↗		5: *10.7 ↙	

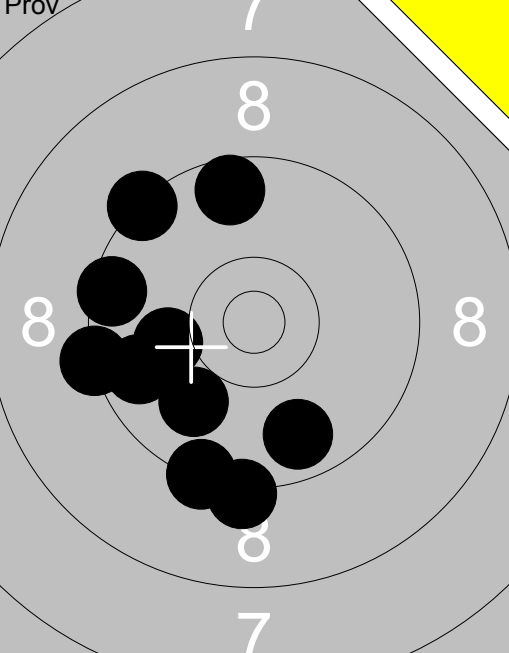
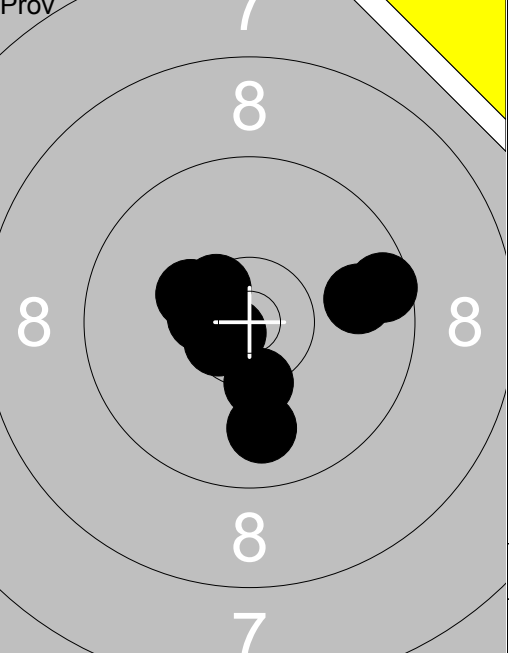
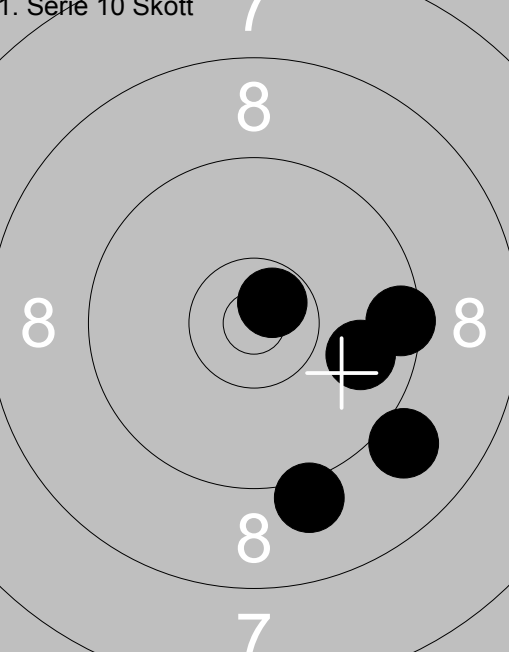
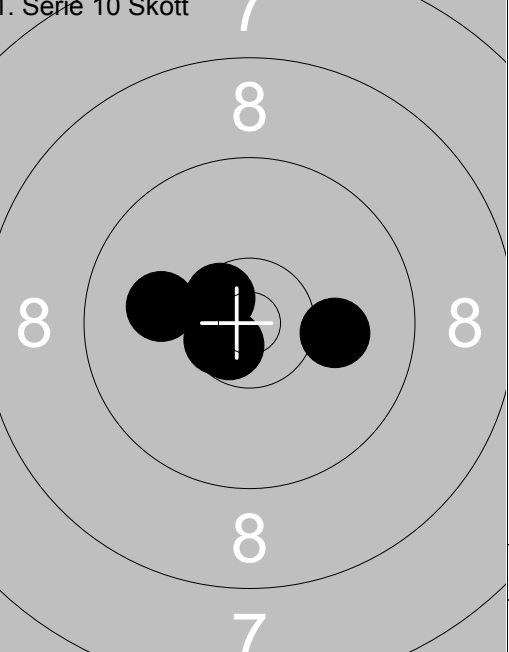
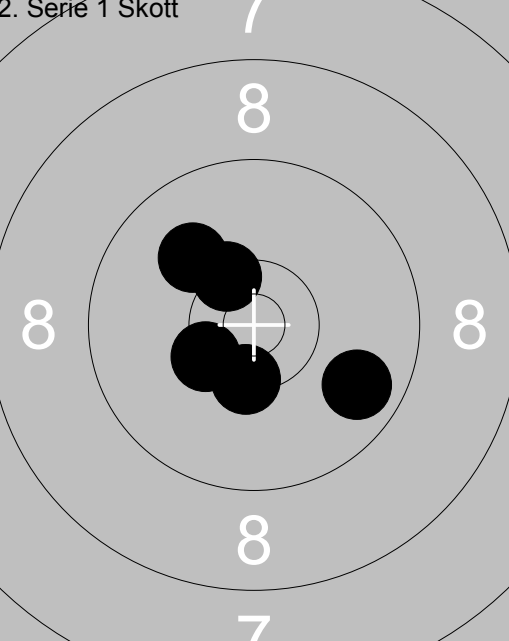
Prov 	1: 9.8 ↓ 2: 9.7 ← 3: 9.5 ← 4: 9.3 ↗ 5: 9.3 ← 6: 9.3 ↓ 7: 9.2 ↓ 8: 9.6 ↑ 9: 10.1 ← 10: 10.0 ↘ <hr/> Serie 92.0 Total 183.0	Prov 	11: 9.9 ↓ 12: 9.6 → 13: 9.8 → 14: *10.5 ← 15: *10.7 ↘ 16: *10.3 ↓ 17: *10.3 ← 18: *10.5 ↘ 19: *10.6 ↘ <hr/> Serie 87.0 Total 183.0
1. Serie 10 Skott 	1: 9.1 ↓ 2: *10.7 ↗ 3: 9.0 ↓ 4: 9.5 → 5: 9.8 → <hr/> Serie 46.0 Total 229.0	1. Serie 10 Skott 	6: 10.1 → 7: *10.6 ↘ 8: *10.6 ↘ 9: *10.6 ↘ 10: 10.0 ← <hr/> Serie 50.0 Total 279.0
2. Serie 1 Skott 	1: 9.8 ↘ 2: *10.4 ↘ 3: 10.0 ↘ 4: *10.4 ↓ 5: *10.4 ↘ <hr/> Serie 49.0 Total 328.0		

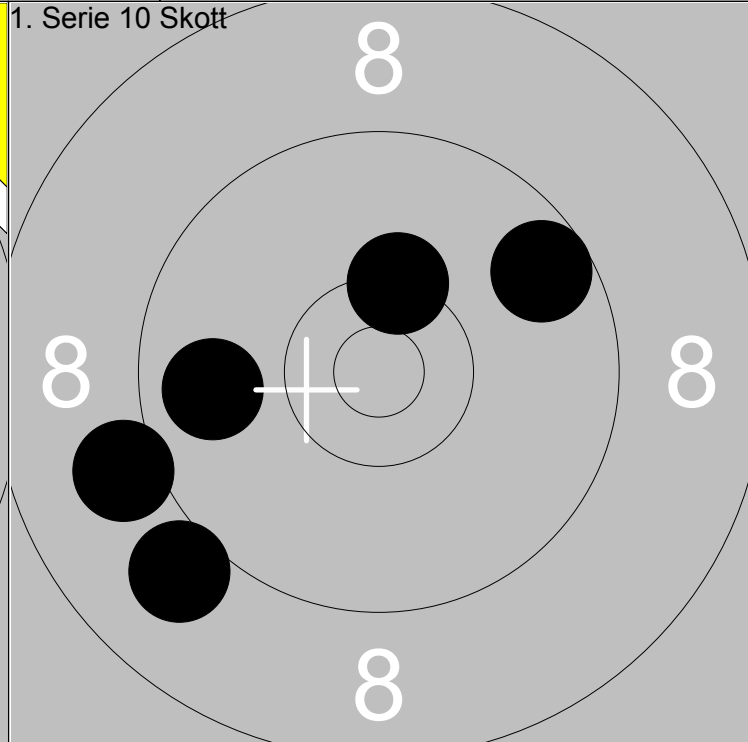
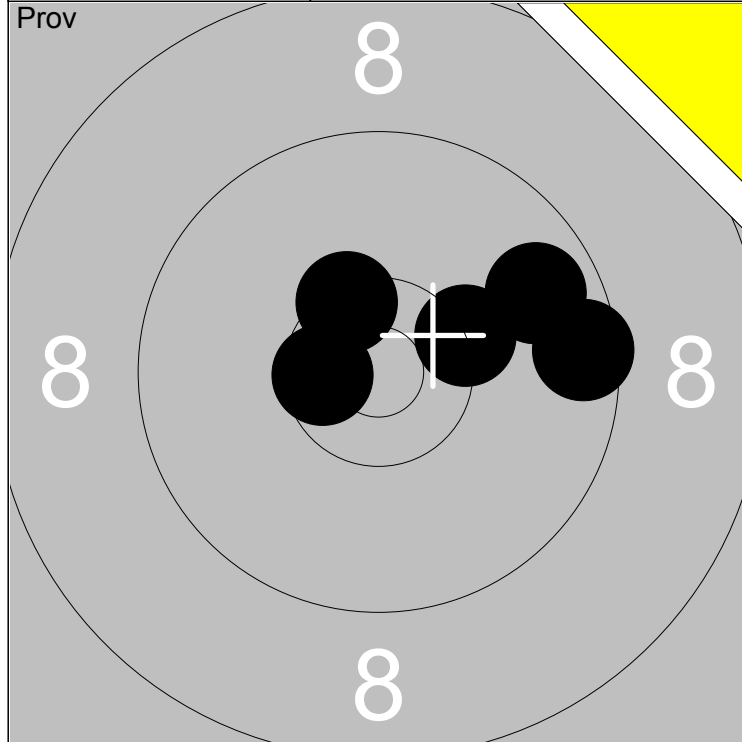

1: *10.6 ←	Serie	48.0
2: 9.7 →		
3: *10.3 →	Total	178.0
4: *10.4 ↗		
5: 9.5 →		

1: 9.1 ←	Serie	46.0
2: 9.0 ↙		
3: 9.8 ←	Total	224.0
4: *10.3 ↗		
5: 9.6 ↗		

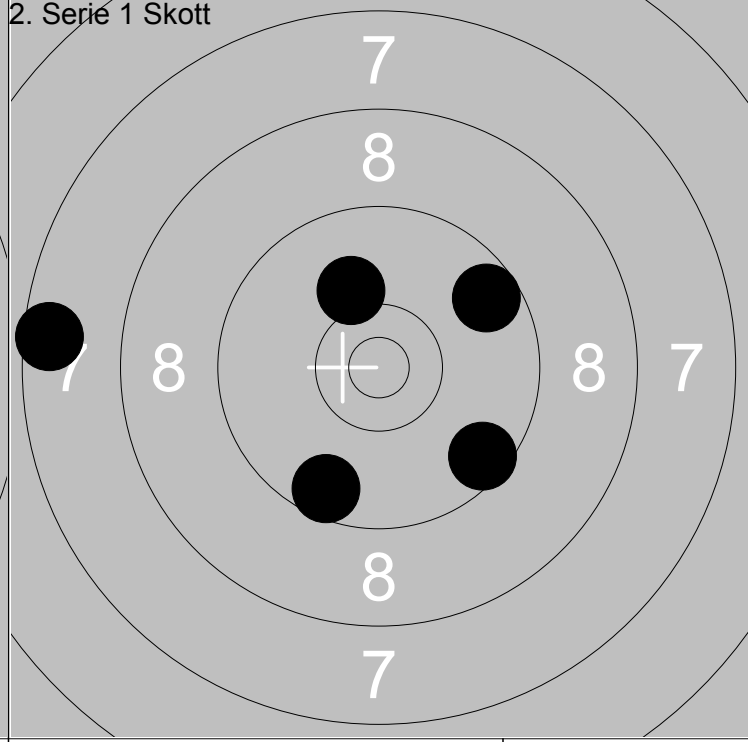
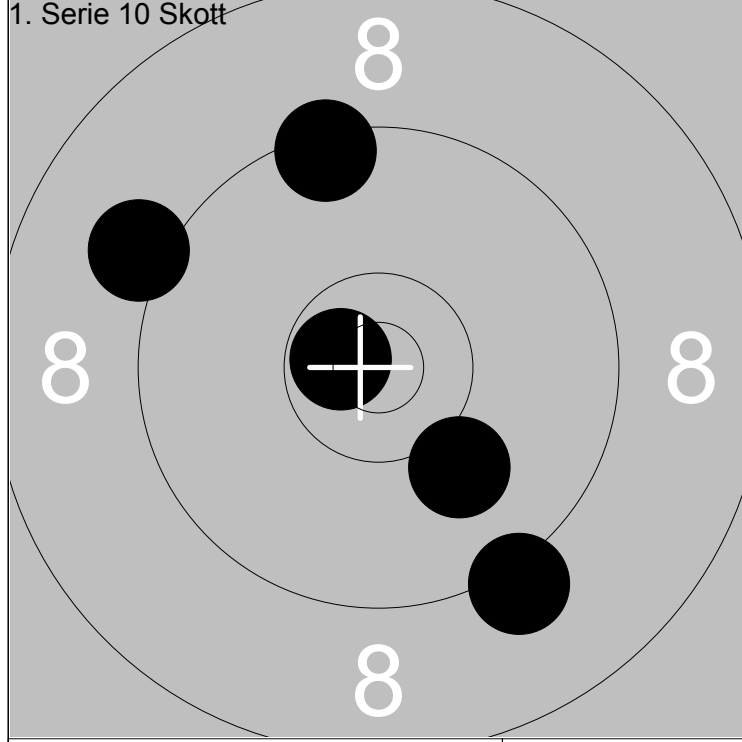

6: 9.1 ↙	Serie	47.0
7: 10.1 ↘		
8: 9.2 ↘	Total	271.0
9: 9.4 ↗		
10: *10.7 ←		

1: 9.6 ↗	Serie	44.0
2: 9.6 ↘		
3: 10.1 ↗	Total	315.0
4: 7.6 ←		
5: 9.6 ↘		

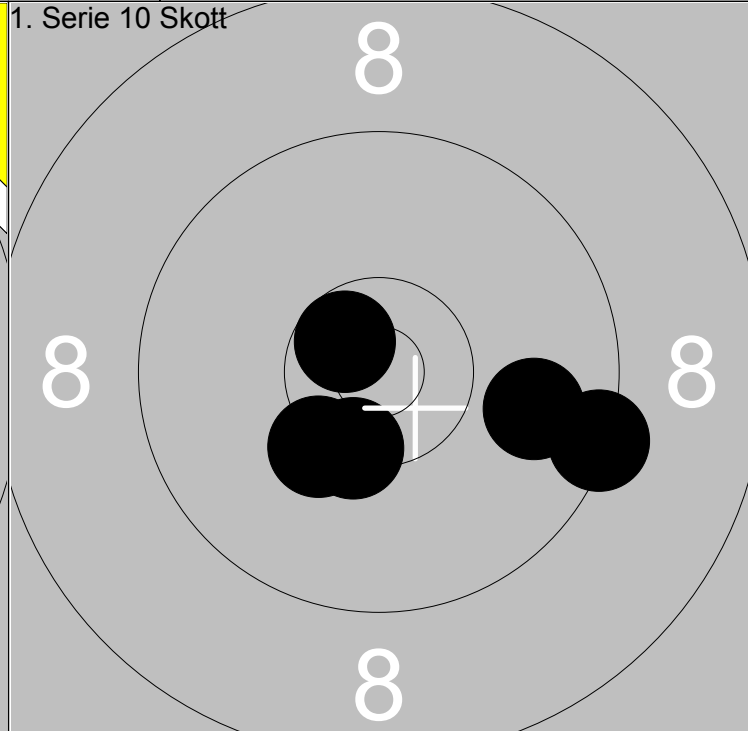
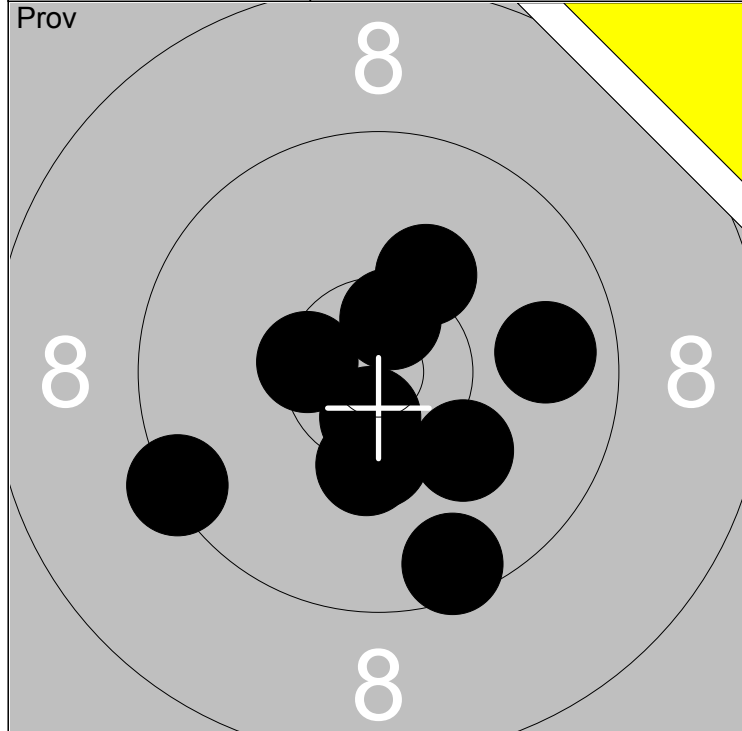

1: 9.5 ↓	6: 10.2 ↗	Serie	97.0
2: 9.4 ↙	7: 10.2 ↘		
3: 9.8 →	8: *10.5 ↖	Total	192.0
4: *10.6 ↗	9: *10.4 ↓		
5: *10.6 ↓	10: *10.3 ↓		

1: *10.6 ↖	Serie	48.0
2: 9.4 →		
3: 9.9 →	Total	240.0
4: *10.3 ↘		
5: *10.4 ↓		

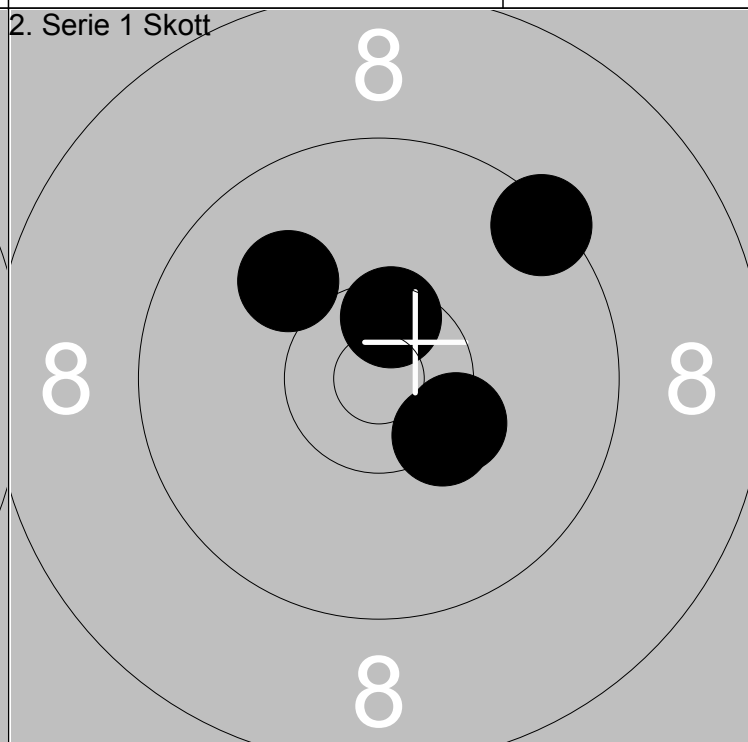
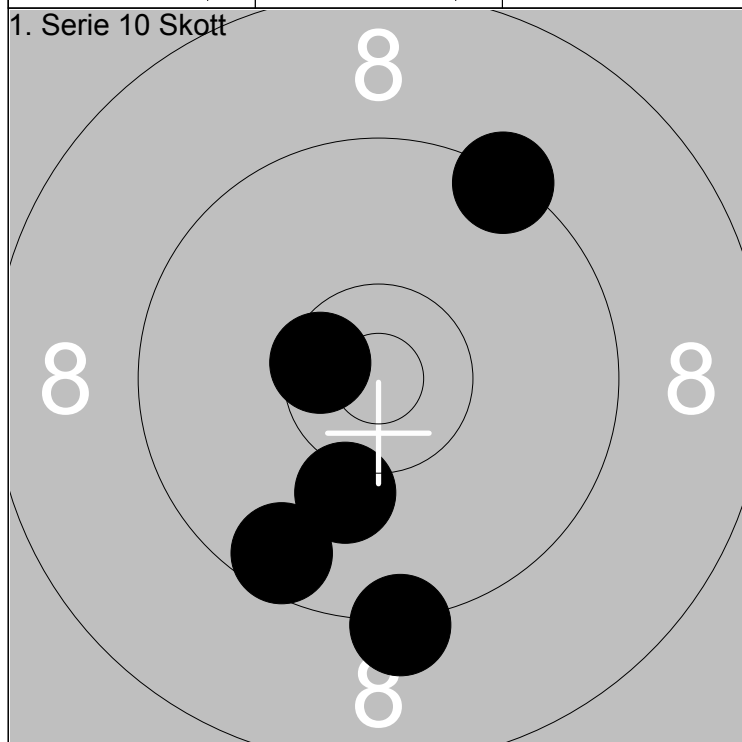

6: 9.3 ↓	Serie	47.0
7: 9.4 ↗		
8: 10.1 ↓	Total	287.0
9: *10.5 ↖		
10: 9.6 ↓		

1: *10.5 ↗	Serie	49.0
2: 10.0 ↖		
3: 9.4 ↗	Total	336.0
4: *10.4 ↘		
5: *10.3 ↘		

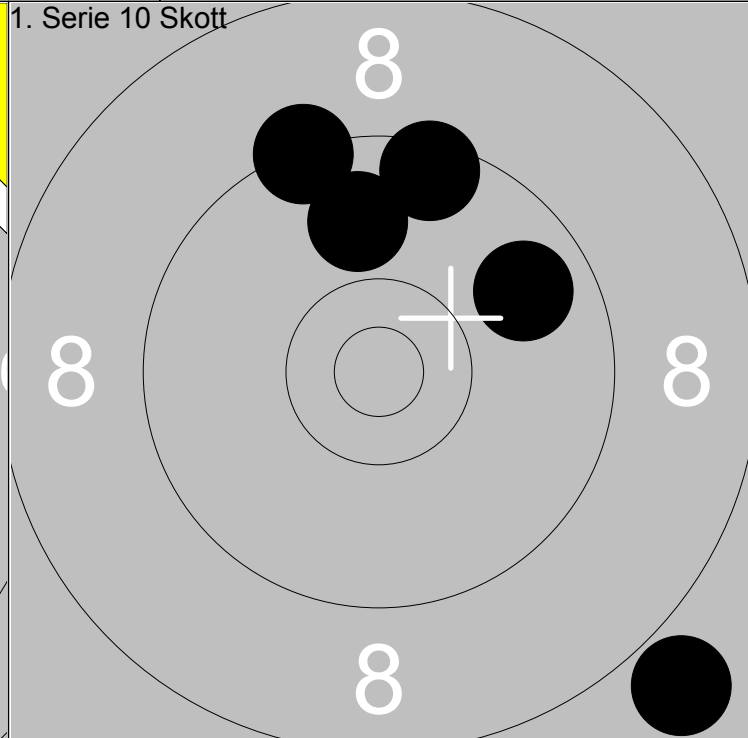
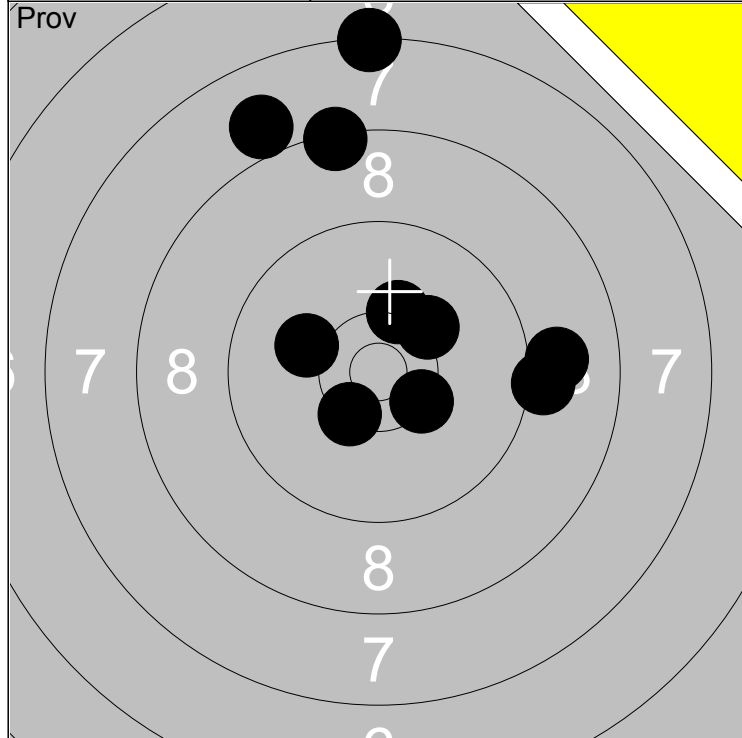

1: 10.1 ↙	6: 8.0 ↗	Serie	91.0
2: *10.4 ↘	7: 8.4 ↑		
3: 9.1 →	8: 10.3 ↗	Total	190.0
4: 9.0 →	9: *10.4 ↘		
5: 7.3 ↑	10: 10.2 ↗		

1: 9.3 ↗	Serie	43.0
2: 7.9 ↘		
3: 9.8 ↗	Total	233.0
4: 9.9 ↑		
5: 9.5 ↑		

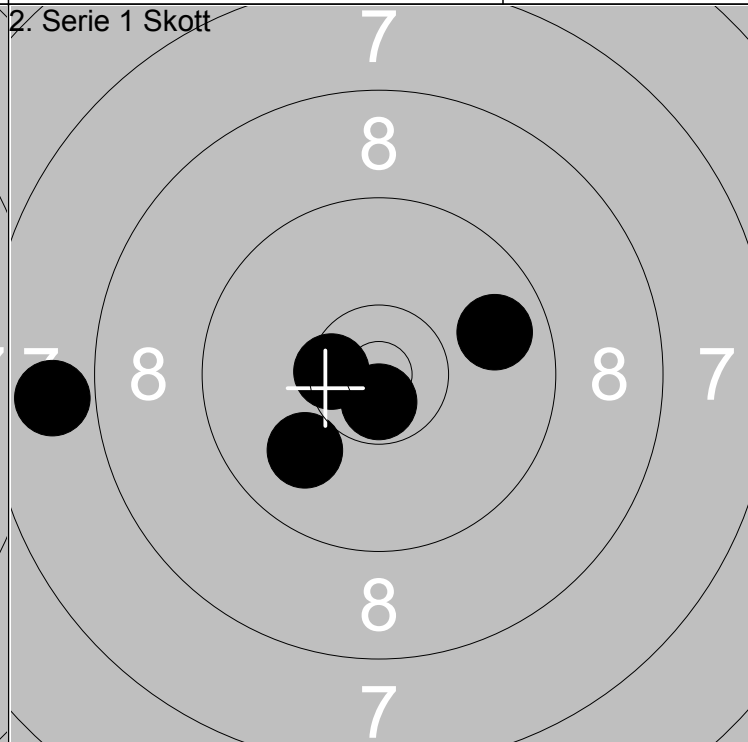
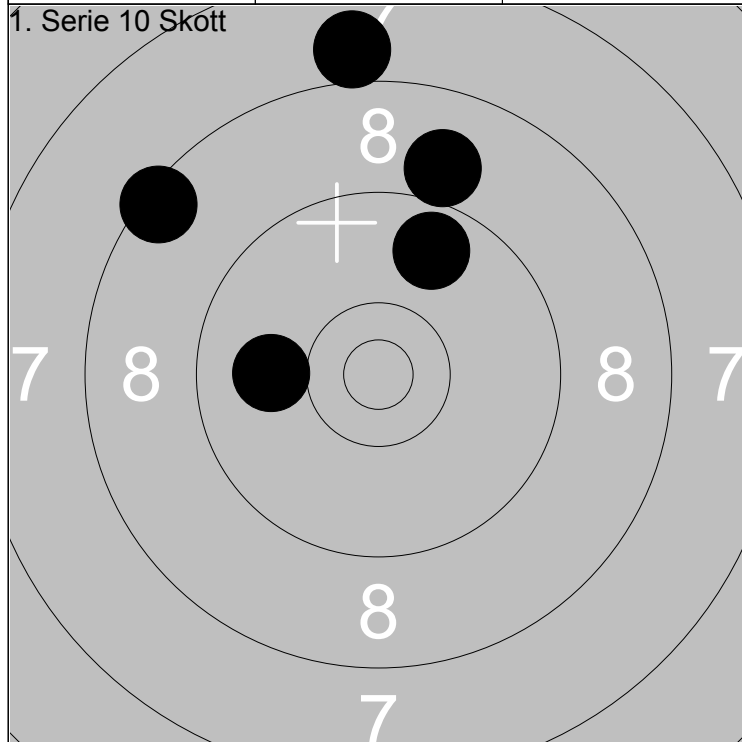

6: 10.0 ←	Serie	44.0
7: 9.0 ↑		
8: 8.0 ↑	Total	277.0
9: 8.4 ↙		
10: 9.7 ↗		

1: *10.5 ←	Serie	46.0
2: 9.8 →		
3: *10.7 ↓	Total	323.0
4: 7.9 ←		
5: 10.0 ↘		

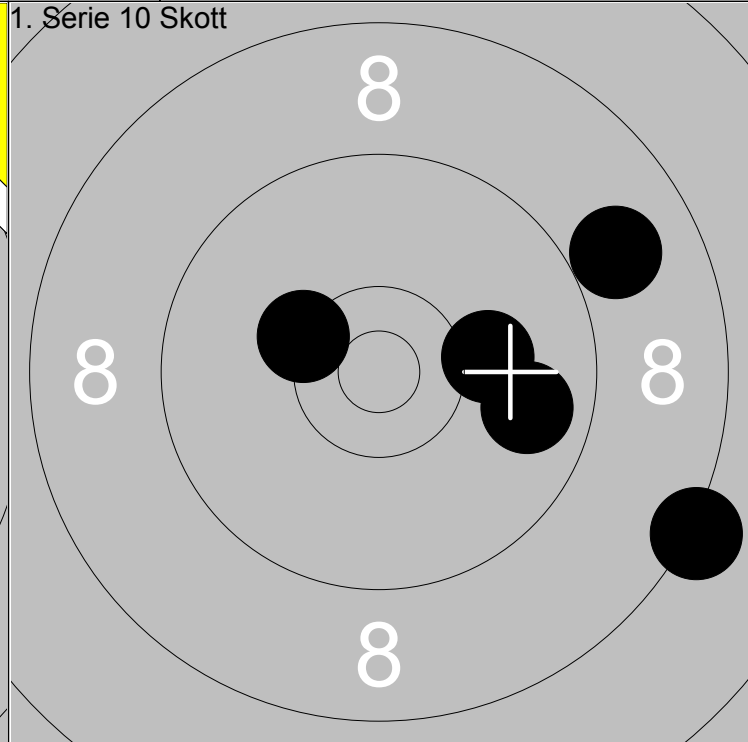
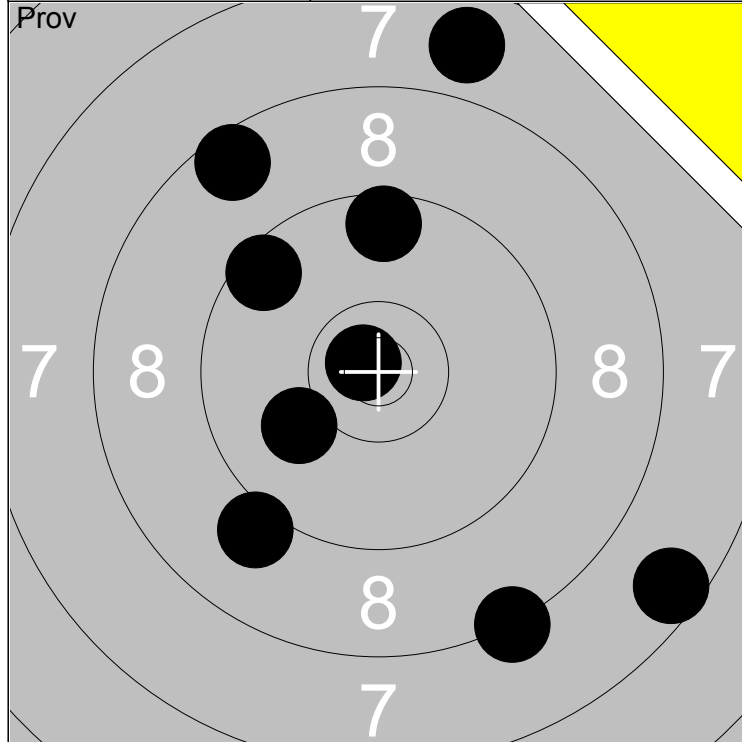

1: 8.6 ↗	6: 7.8 ↑	Serie	77.0
2: *10.8 ↖	7: 10.1 ↙		
3: 7.6 ↘	8: 9.1 ↙	Total	183.0
4: 8.3 ↘	9: 9.5 ↖		
5: 9.6 ↑			

1: *10.3 ↖	Serie	45.0
2: 8.9 ↗		
3: 9.8 →	Total	228.0
4: 8.2 ↘		
5: 10.1 →		

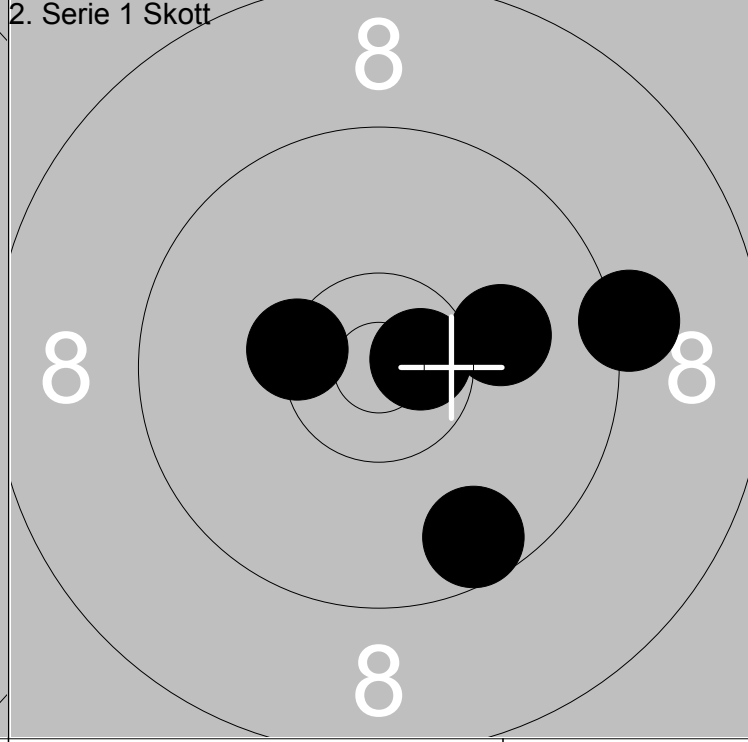
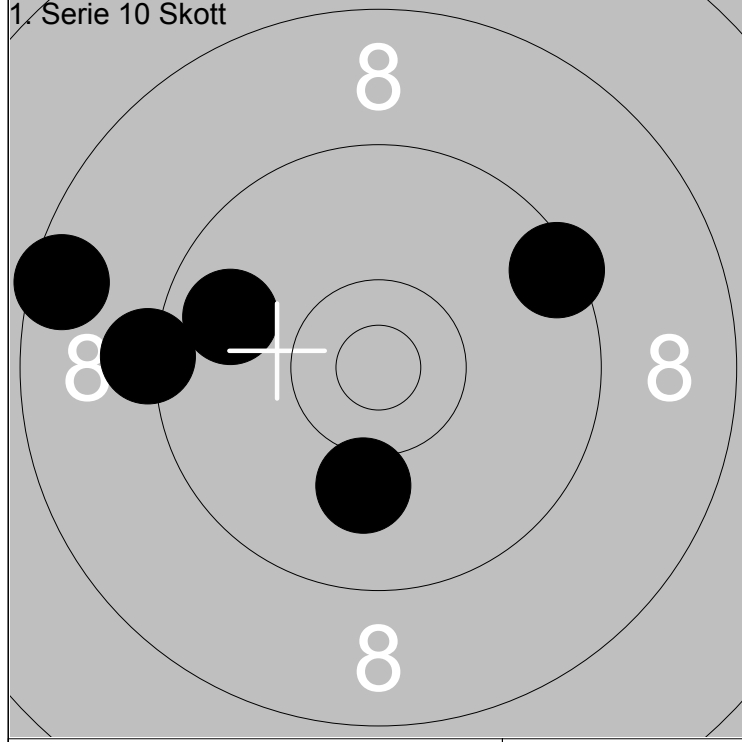

6: 9.4 ↗	Serie	45.0
7: 9.2 ←		
8: 9.8 ←	Total	273.0
9: 8.5 ←		
10: 10.1 ↓		

1: *10.7 →	Serie	48.0
2: 9.6 ↘		
3: *10.4 ↖	Total	321.0
4: 10.1 →		
5: 9.2 →		

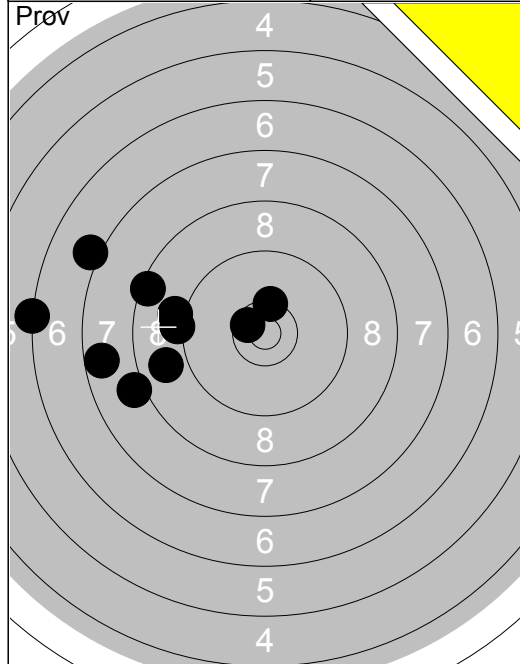

1:	7.1	↙
2:	8.4	↙
3:	*10.6	↘
4:	9.2	↙
5:	9.1	↙
6:	*10.3	↑
7:	6.3	↙
8:	8.1	↙
9:	7.6	↙
10:	8.9	↙
Serie		82.0
Total		175.0

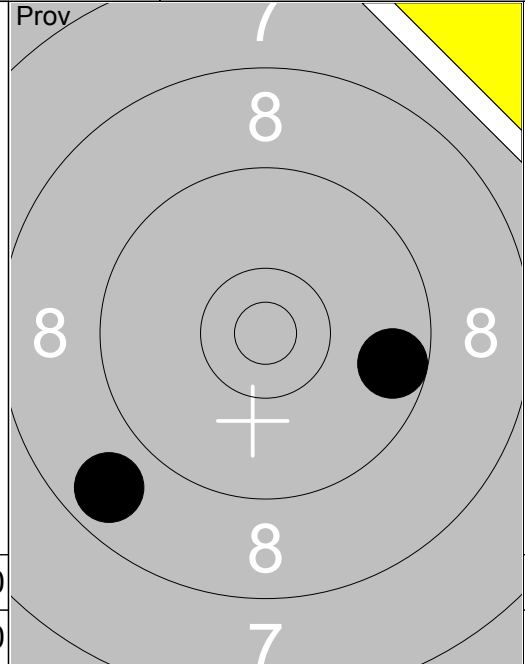

11:	8.8	↘
12:	9.6	→
Serie		17.0
Total		175.0

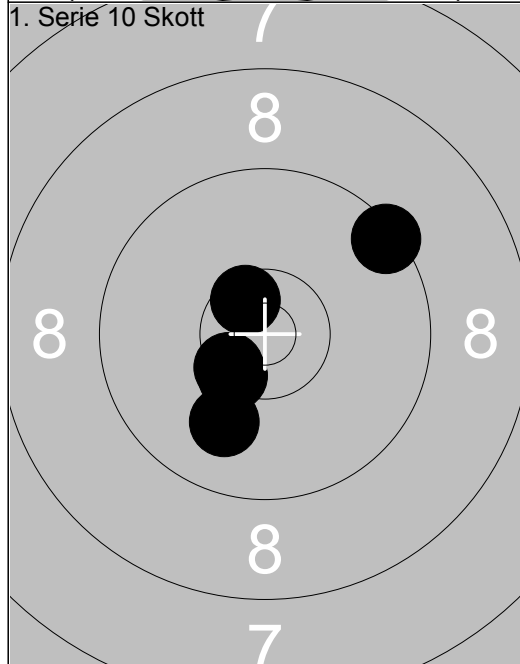

1:	10.0	↘
2:	9.4	↗
3:	*10.5	↘
4:	*10.4	↘
5:	*10.6	↘
Serie		49.0
Total		224.0

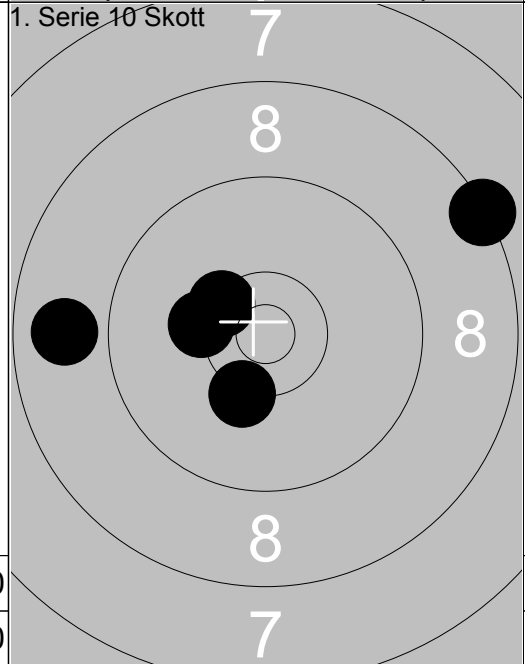

6:	10.3	↙
7:	8.8	↙
8:	10.3	↘
9:	8.3	↗
10:	*10.4	↘
Serie		46.0
Total		270.0

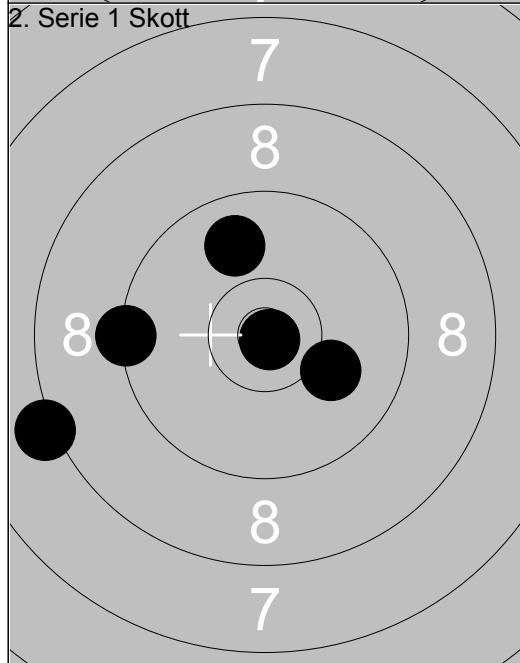

1:	10.1	↘
2:	8.2	↙
3:	9.4	↙
4:	9.9	↑
5:	*10.9	↘
Serie		46.0
Total		316.0

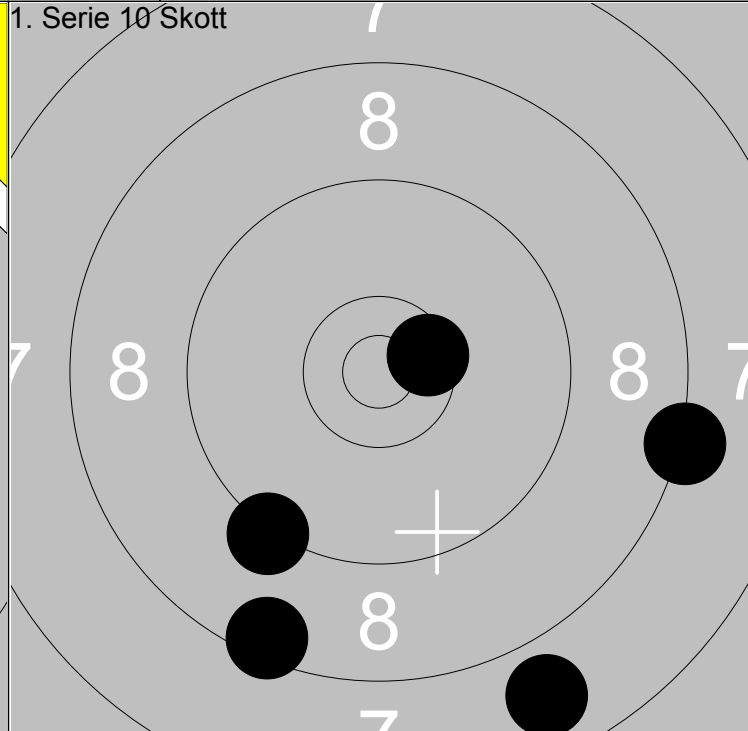
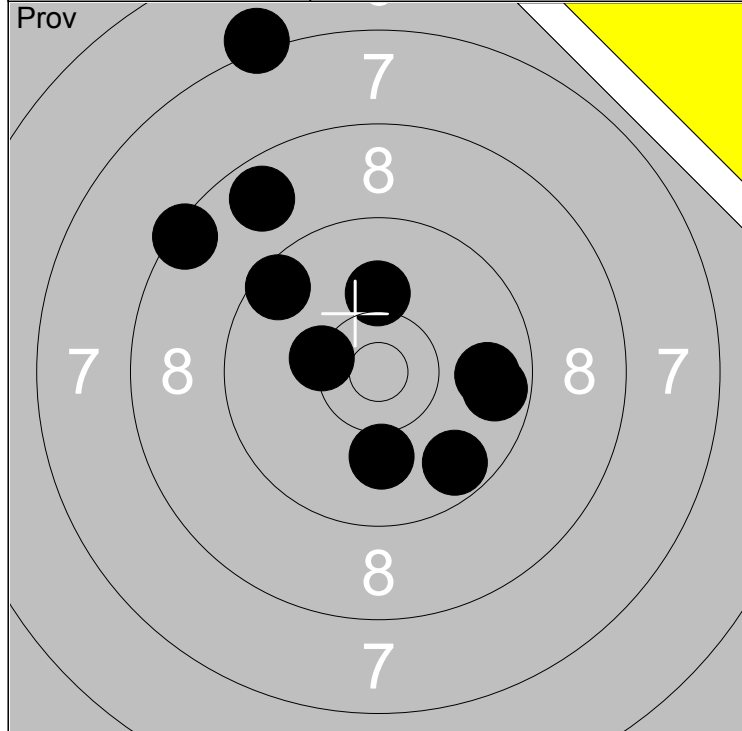

1: *10.3 ←	6: 9.7 ↓	Serie	89.0
2: 8.4 ↗	7: 9.5 ↗		
3: 9.8 →	8: 10.0 ↓	Total	170.0
4: 7.2 ↗	9: 9.7 →		
5: 8.7 ↗	10: 10.1 ↑		

1: *10.5 →	Serie	42.0
2: 8.2 →		
3: 8.5 ↓	Total	212.0
4: 7.8 ↓		
5: 9.3 ↓		

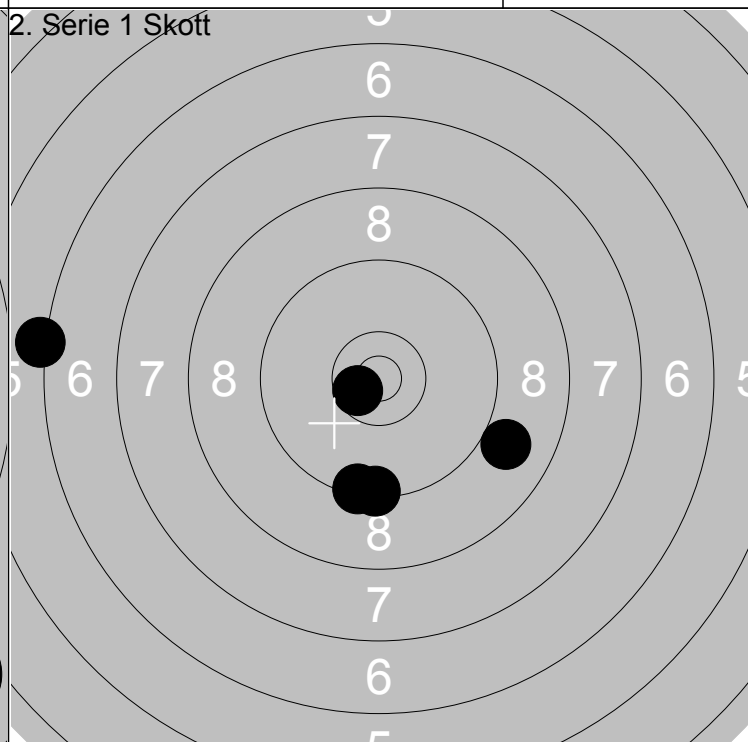
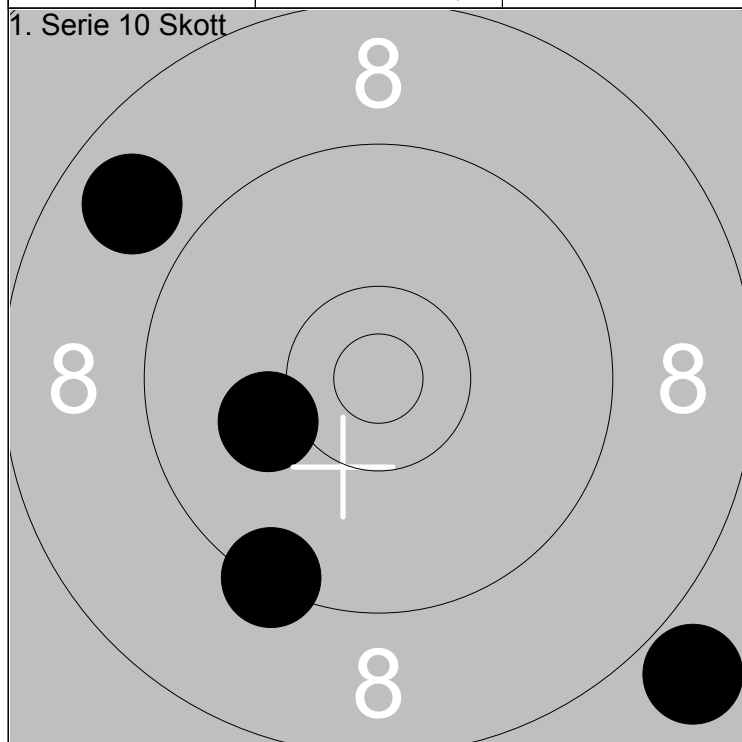

6: 8.8 ↗	Serie	34.0
7: 7.9 ↓		
8: 9.4 ↓	Total	246.0
9: 0.0		
10: 10.1 ←		

1: 6.2 ←	Serie	43.0
2: 9.4 ↓		
3: *10.6 ↙	Total	289.0
4: 9.4 ↓		
5: 9.0 →		

<p>Prov</p>	<p>1: 8.9 ↑</p> <p>2: 9.1 ↑</p> <p>3: *10.3 ↘</p> <p>4: 7.7 ↑</p> <p>5: 10.2 ↘</p> <p>6: 10.2 ↙</p> <p>7: 8.7 ↑</p> <p>8: 9.9 ↑</p> <p>9: 9.0 ↖</p> <p>10: 9.2 ↖</p>	<p>Prov</p>	<p>11: 7.2 ↗</p> <p>12: 9.1 ↗</p>
Serie 89.0		Serie 16.0	
Total 169.0		Total 169.0	

<p>1. Serie 10 Skott</p>	<p>1: 7.7 ↙</p> <p>2: 9.2 ↓</p> <p>3: 9.8 →</p> <p>4: 8.6 ↑</p> <p>5: 8.1 ↗</p>	<p>1. Serie 10 Skott</p>	<p>6: 9.5 ↑</p> <p>7: 8.0 ↖</p> <p>8: 9.4 ←</p> <p>9: 8.8 ↖</p> <p>10: 9.7 ↑</p>
Serie 41.0		Serie 43.0	
Total 210.0		Total 253.0	

<p>2. Serie 1 Skott</p>	<p>1: *10.5 ↘</p> <p>2: 8.0 ↑</p> <p>3: 9.7 ↖</p> <p>4: 9.9 →</p> <p>5: 7.3 ↑</p>		
Serie 43.0			
Total 296.0			

	<p>1: 9.9 ←</p> <p>2: 10.0 ↙</p> <p>3: *10.6 ↘</p> <p>4: *10.8 ↓</p> <p>5: 9.2 ↑</p> <p>6: *10.6 ↓</p> <p>7: 10.3 ↙</p> <p>8: 9.0 ↙</p> <p>9: 10.1 ↑</p> <p>10: 9.7 ↓</p>		<p>11: 10.1 →</p> <p>12: 10.2 →</p> <p>13: 9.7 ↑</p> <p>14: 9.5 →</p> <p>15: 10.0 ↑</p> <p>16: 9.4 →</p> <p>17: *10.5 ↓</p>
Serie 96.0		Serie 67.0	
Total 188.0		Total 188.0	

<p>1. Serie 10 Skott</p>	<p>1: *10.6 ↗</p> <p>2: 9.5 →</p> <p>3: 7.9 →</p> <p>4: *10.7 ↓</p> <p>5: 9.7 ↓</p>	<p>1. Serie 10 Skott</p>	<p>6: 10.3 ↗</p> <p>7: *10.4 ↗</p> <p>8: 9.9 ↗</p> <p>9: *10.4 ↗</p> <p>10: 9.2 ↓</p>
Serie 45.0		Serie 48.0	
Total 233.0		Total 281.0	

<p>2. Serie 1 Skott</p>	<p>1: 9.4 ↗</p> <p>2: 10.0 ↑</p> <p>3: *10.3 →</p> <p>4: 9.5 ↗</p> <p>5: 9.5 ←</p>		
Serie 47.0			
Total 328.0			

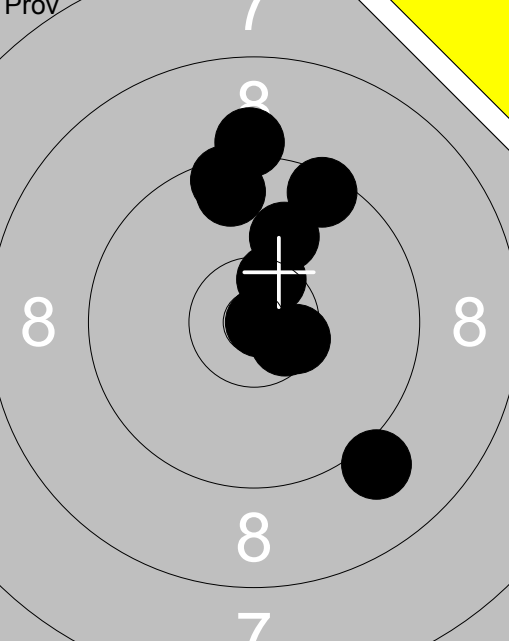
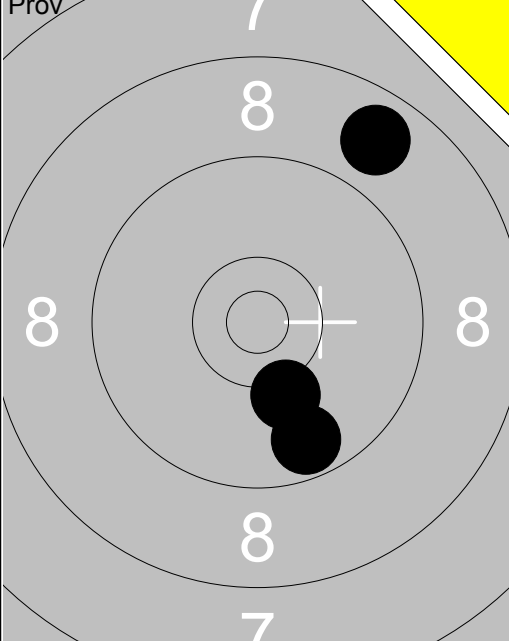
	<p>1: *10.9 →</p> <p>2: 9.6 ↑</p> <p>3: 10.0 ↑</p> <p>4: 9.1 ↓</p> <p>5: *10.6 →</p> <p>6: 9.5 ↗</p> <p>7: *10.5 ↗</p> <p>8: *10.5 →</p> <p>9: 9.5 ↑</p> <p>10: 9.2 ↑</p>		<p>11: 10.2 ↓</p> <p>12: 9.7 ↓</p> <p>13: 8.8 ↗</p>
Serie	95.0	Serie	27.0
Total	186.0	Total	186.0

<p>1. Serie 10 Skott</p> 	<p>1: *10.5 ↗</p> <p>2: 9.7 ↗</p> <p>3: 10.0 ↗</p> <p>4: 9.1 →</p> <p>5: 8.5 →</p>		<p>6: 9.9 →</p> <p>7: 9.7 ↓</p> <p>8: *10.7 ↗</p> <p>9: 9.0 ↗</p> <p>10: *10.7 ↗</p>
Serie	46.0	Serie	47.0
Total	232.0	Total	279.0

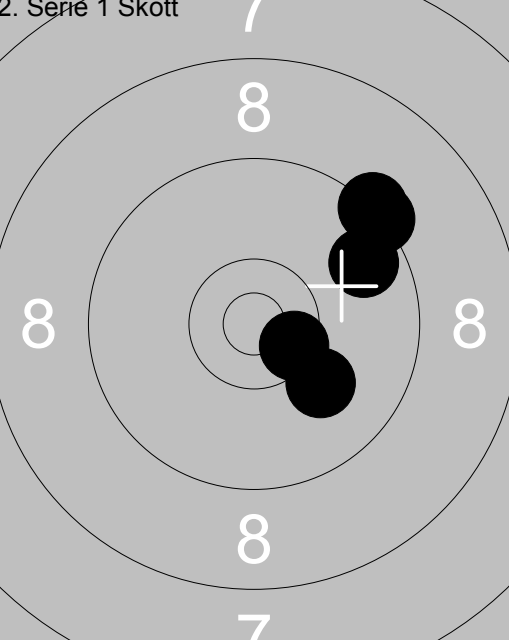
<p>2. Serie 1 Skott</p> 	<p>1: *10.5 →</p> <p>2: 9.7 ↗</p> <p>3: 9.3 ↗</p> <p>4: 9.3 ↗</p> <p>5: 10.1 ↓</p>		
Serie	47.0		
Total	326.0		

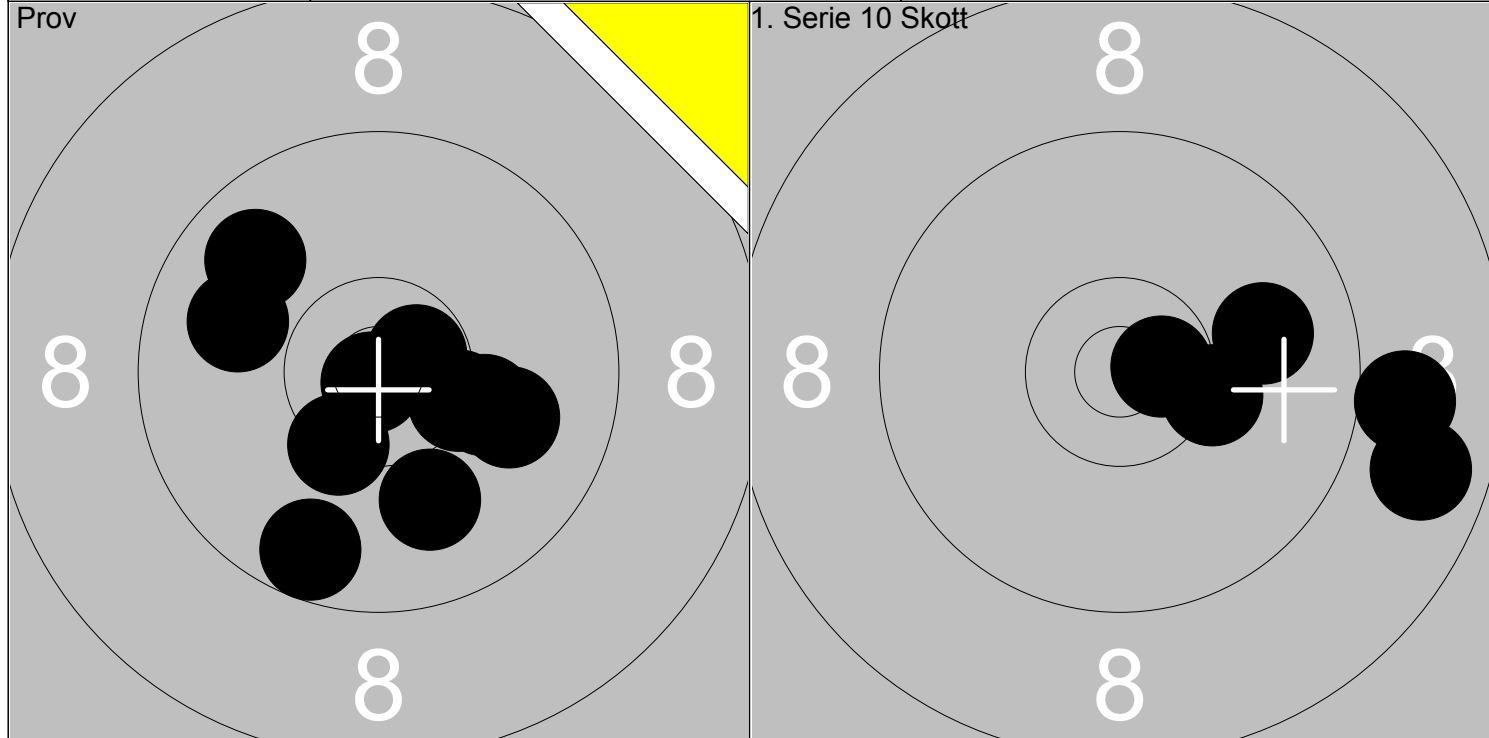

1: 10.0 ↓	6: 9.8 ↗			1: *10.7 →			
2: *10.4 ↓	7: 10.0 →	Serie	97.0	2: *10.3 →	Serie	46.0	
3: *10.4 →	8: *10.9 ↓			3: 9.0 →			
4: 9.6 ↓	9: 10.2 →	Total	193.0	4: 8.8 →	Total	239.0	
5: 9.9 ←	10: *10.7 →			5: 9.9 →			

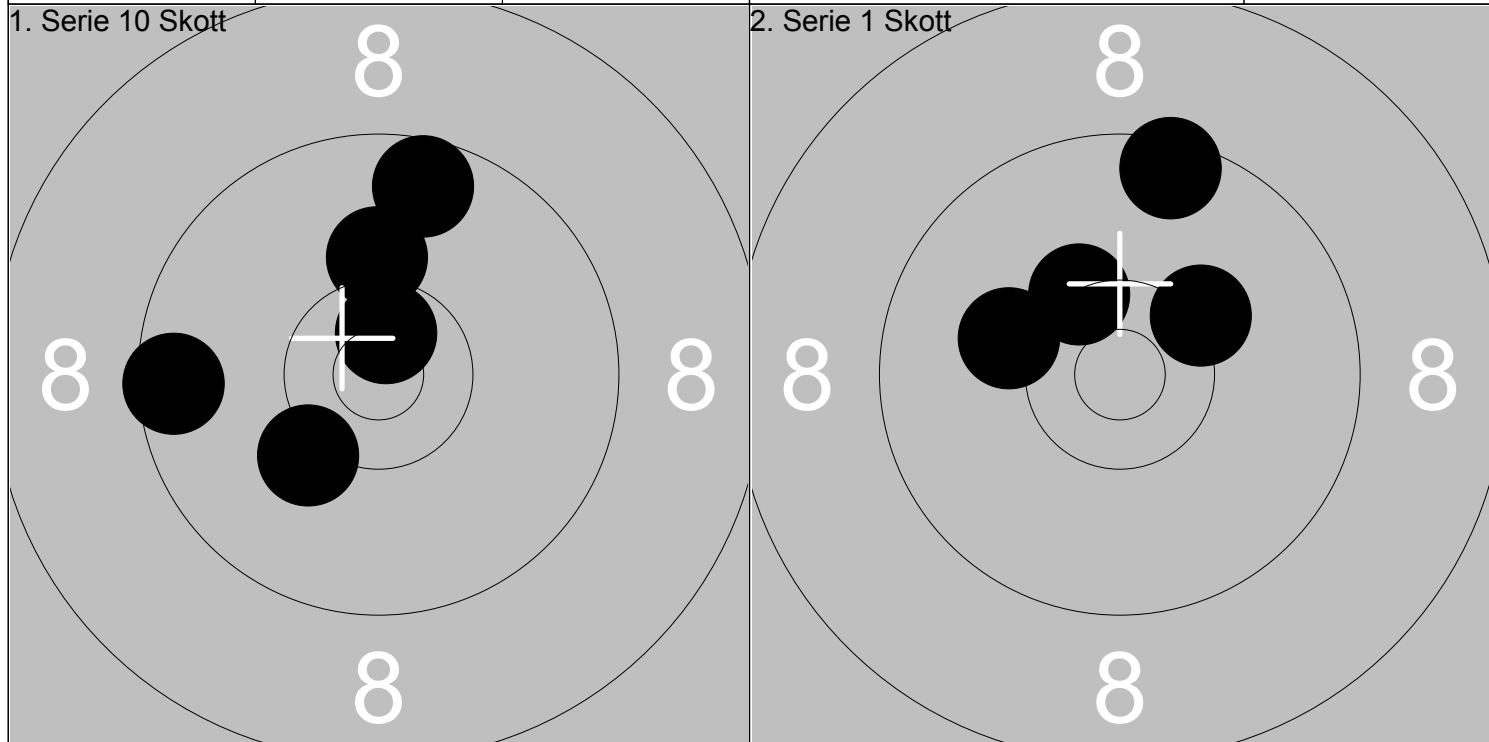

6: *10.7 ↑				1: 10.1 ←			
7: 9.5 ←	Serie	48.0		2: 10.3 ↗	Serie	39.0	
8: 9.6 ↑				3: 0.0			
9: 10.2 ↓	Total	287.0		4: 9.5 ↑	Total	326.0	
10: 10.1 ↑				5: *10.3 ↖			

		<table style="width:100%; border-collapse: collapse;"> <tr> <td style="border-bottom: 1px solid black;">1: 9.2 ↖</td> <td style="border-bottom: 1px solid black;">11: *10.4 →</td> </tr> <tr> <td style="border-bottom: 1px solid black;">2: *10.7 ↖</td> <td style="border-bottom: 1px solid black;">12: 9.6 ↓</td> </tr> <tr> <td style="border-bottom: 1px solid black;">3: 9.5 ↖</td> <td style="border-bottom: 1px solid black;">13: 9.8 ←</td> </tr> <tr> <td style="border-bottom: 1px solid black;">4: 10.1 ↘</td> <td style="border-bottom: 1px solid black;">14: *10.3 ↖</td> </tr> <tr> <td style="border-bottom: 1px solid black;">5: *10.4 ↓</td> <td style="border-bottom: 1px solid black;">15: 10.1 ↓</td> </tr> <tr> <td style="border-bottom: 1px solid black;">6: 9.8 ↓</td> <td style="border-bottom: 1px solid black;">16: 8.5 ↘</td> </tr> <tr> <td style="border-bottom: 1px solid black;">7: 10.2 ↘</td> <td style="border-bottom: 1px solid black;">17: *10.3 ↖</td> </tr> <tr> <td style="border-bottom: 1px solid black;">8: *10.5 ↓</td> <td style="border-bottom: 1px solid black;">18: 10.0 ↘</td> </tr> <tr> <td style="border-bottom: 1px solid black;">9: 9.1 ←</td> <td></td> </tr> <tr> <td style="border-bottom: 1px solid black;">10: 10.2 ↓</td> <td></td> </tr> <tr> <td style="border-bottom: 1px solid black;">Serie 96.0</td> <td style="border-bottom: 1px solid black;">Serie 76.0</td> </tr> <tr> <td style="border-bottom: 1px solid black;">Total 191.0</td> <td style="border-bottom: 1px solid black;">Total 191.0</td> </tr> </table>	1: 9.2 ↖	11: *10.4 →	2: *10.7 ↖	12: 9.6 ↓	3: 9.5 ↖	13: 9.8 ←	4: 10.1 ↘	14: *10.3 ↖	5: *10.4 ↓	15: 10.1 ↓	6: 9.8 ↓	16: 8.5 ↘	7: 10.2 ↘	17: *10.3 ↖	8: *10.5 ↓	18: 10.0 ↘	9: 9.1 ←		10: 10.2 ↓		Serie 96.0	Serie 76.0	Total 191.0	Total 191.0
1: 9.2 ↖	11: *10.4 →																									
2: *10.7 ↖	12: 9.6 ↓																									
3: 9.5 ↖	13: 9.8 ←																									
4: 10.1 ↘	14: *10.3 ↖																									
5: *10.4 ↓	15: 10.1 ↓																									
6: 9.8 ↓	16: 8.5 ↘																									
7: 10.2 ↘	17: *10.3 ↖																									
8: *10.5 ↓	18: 10.0 ↘																									
9: 9.1 ←																										
10: 10.2 ↓																										
Serie 96.0	Serie 76.0																									
Total 191.0	Total 191.0																									

<p>1. Serie 10 Skott</p>	<p>1. Serie 10 Skott</p>	<table style="width:100%; border-collapse: collapse;"> <tr> <td style="border-bottom: 1px solid black;">1: 9.9 ←</td> <td style="border-bottom: 1px solid black;">6: 10.2 ↘</td> </tr> <tr> <td style="border-bottom: 1px solid black;">2: 9.9 ↓</td> <td style="border-bottom: 1px solid black;">7: 9.4 ↓</td> </tr> <tr> <td style="border-bottom: 1px solid black;">3: 9.5 ↘</td> <td style="border-bottom: 1px solid black;">8: *10.3 ↘</td> </tr> <tr> <td style="border-bottom: 1px solid black;">4: 8.0 ↘</td> <td style="border-bottom: 1px solid black;">9: 9.2 ←</td> </tr> <tr> <td style="border-bottom: 1px solid black;">5: 10.0 →</td> <td style="border-bottom: 1px solid black;">10: 9.7 ←</td> </tr> <tr> <td style="border-bottom: 1px solid black;">Serie 45.0</td> <td style="border-bottom: 1px solid black;">Serie 47.0</td> </tr> <tr> <td style="border-bottom: 1px solid black;">Total 236.0</td> <td style="border-bottom: 1px solid black;">Total 283.0</td> </tr> </table>	1: 9.9 ←	6: 10.2 ↘	2: 9.9 ↓	7: 9.4 ↓	3: 9.5 ↘	8: *10.3 ↘	4: 8.0 ↘	9: 9.2 ←	5: 10.0 →	10: 9.7 ←	Serie 45.0	Serie 47.0	Total 236.0	Total 283.0
1: 9.9 ←	6: 10.2 ↘															
2: 9.9 ↓	7: 9.4 ↓															
3: 9.5 ↘	8: *10.3 ↘															
4: 8.0 ↘	9: 9.2 ←															
5: 10.0 →	10: 9.7 ←															
Serie 45.0	Serie 47.0															
Total 236.0	Total 283.0															

<p>2. Serie 1 Skott</p>												
<table style="width:100%; border-collapse: collapse;"> <tr> <td style="border-bottom: 1px solid black;">1: 9.6 ↓</td> <td style="border-bottom: 1px solid black;">2: 10.2 →</td> </tr> <tr> <td style="border-bottom: 1px solid black;">3: *10.7 ↘</td> <td style="border-bottom: 1px solid black;">4: 10.1 →</td> </tr> <tr> <td style="border-bottom: 1px solid black;">5: *10.5 ↘</td> <td></td> </tr> <tr> <td style="border-bottom: 1px solid black;">Serie 49.0</td> <td></td> </tr> <tr> <td style="border-bottom: 1px solid black;">Total 332.0</td> <td></td> </tr> </table>	1: 9.6 ↓	2: 10.2 →	3: *10.7 ↘	4: 10.1 →	5: *10.5 ↘		Serie 49.0		Total 332.0			
1: 9.6 ↓	2: 10.2 →											
3: *10.7 ↘	4: 10.1 →											
5: *10.5 ↘												
Serie 49.0												
Total 332.0												

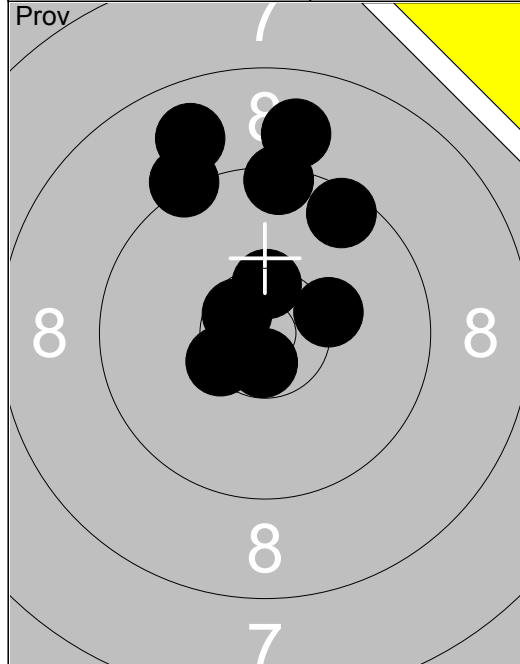

1:	8.9	↑
2:	8.9	↑
3:	9.2	↖
4:	*10.5	↑
5:	*10.6	↖
6:	*10.7	↓
7:	*10.4	↙
8:	9.4	↑
9:	10.3	→
10:	9.5	↗
Serie		93.0
Total		186.0

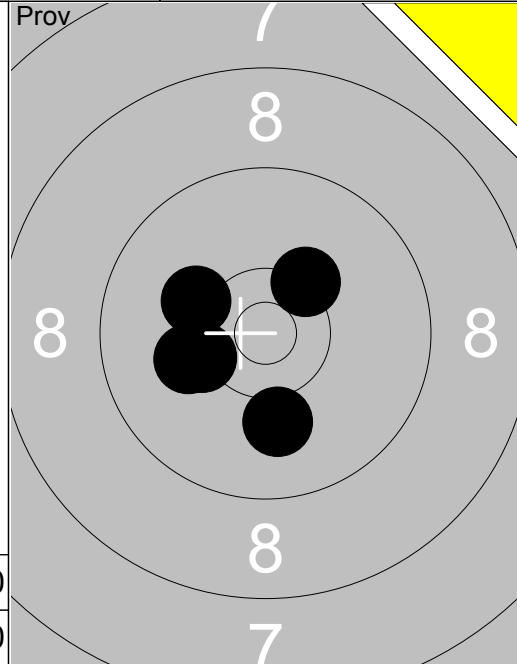

11:	10.1	↓
12:	10.3	↙
13:	*10.3	↗
14:	10.2	↖
15:	10.1	↙
Serie		50.0
Total		186.0

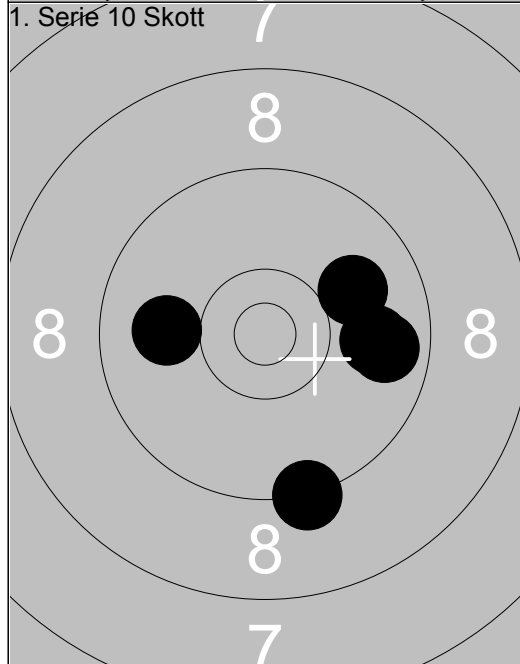

1:	10.0	↙
2:	9.8	→
3:	10.0	↗
4:	9.3	↓
5:	9.9	→
Serie		47.0
Total		233.0

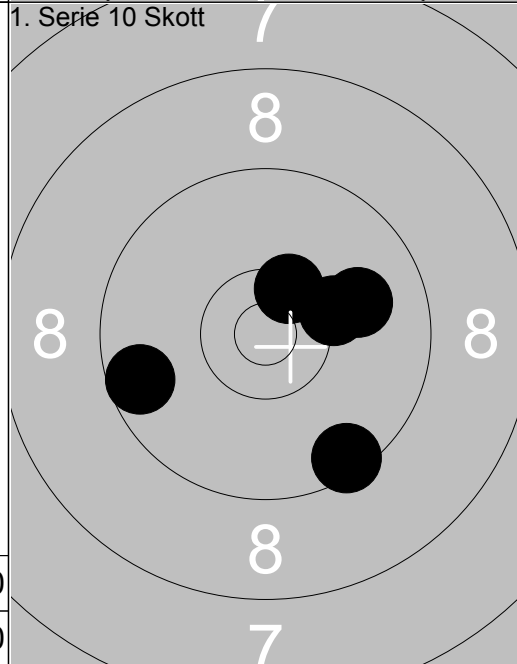

6:	10.2	→
7:	*10.4	↗
8:	10.0	→
9:	9.6	↙
10:	9.5	↓
Serie		48.0
Total		281.0

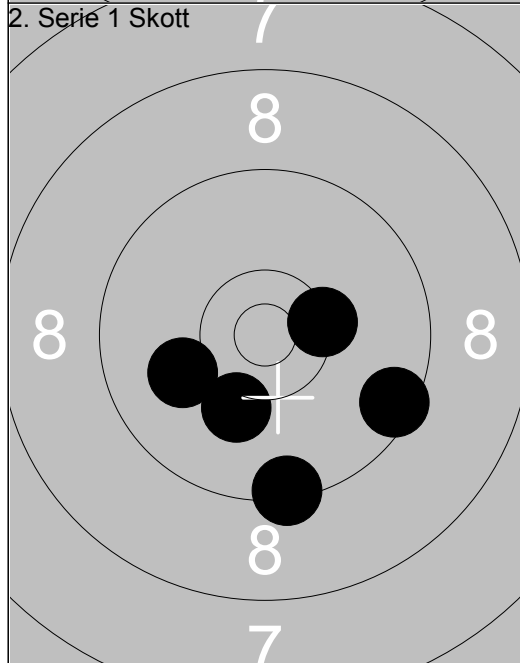

1:	10.2	↓
2:	9.4	↓
3:	9.5	↗
4:	10.0	↙
5:	*10.4	→
Serie		48.0
Total		329.0

	<p>1: 10.0 ↑</p> <p>2: 9.7 ↖</p> <p>3: 8.8 ↑</p> <p>4: *10.6 ↘</p> <p>5: *10.4 ←</p> <p>6: 9.9 ↘</p> <p>7: 10.1 ←</p> <p>8: *10.5 ↘</p> <p>9: 10.2 ↘</p> <p>10: 9.9 ↗</p>		<p>11: 9.6 →</p> <p>12: *10.6 ↘</p> <p>13: 10.0 →</p> <p>14: *10.7 ↗</p>
7	Serie 95.0	7	Serie 39.0
8	Total 183.0	8	Total 183.0

<p>1. Serie 10 Skott</p>	<p>1: 10.0 ↘</p> <p>2: *10.6 ↗</p> <p>3: *10.6 ↘</p> <p>4: *10.6 →</p> <p>5: *10.6 ↘</p>		<p>6: *10.7 ↗</p> <p>7: 9.7 ↗</p> <p>8: *10.3 ↘</p> <p>9: 9.8 →</p> <p>10: *10.7 ↘</p>
7	Serie 50.0	7	Serie 48.0
8	Total 233.0	8	Total 281.0

<p>2. Serie 1 Skott</p>	<p>1: *10.7 ↗</p> <p>2: 9.6 ↙</p> <p>3: *10.3 ↘</p> <p>4: *10.6 ↘</p> <p>5: *10.7 ↗</p>		
7	Serie 49.0		
8	Total 330.0		

	<p>1: 9.0 ↗ 2: *10.5 ↓ 3: *10.6 ↗ 4: *10.3 ↘ 5: 10.1 ↖ 6: *10.5 ↘ 7: 9.9 → 8: 9.5 → 9: 9.8 ↓ 10: 9.6 ↘</p>		<p>11: 9.9 ↗ 12: 10.3 ↑</p>
Serie 95.0		Serie 19.0	
Total 186.0		Total 186.0	

<p>1. Serie 10 Skott</p>	<p>1: 10.1 ↗ 2: *10.5 ↓ 3: *10.3 ↗ 4: *10.4 → 5: *10.4 ↘</p>		<p>6: 9.9 ↑ 7: 9.6 ↑ 8: 9.6 ↑ 9: 10.0 ↓ 10: 9.9 ←</p>
Serie 50.0		Serie 46.0	
Total 236.0		Total 282.0	

<p>2. Serie 1 Skott</p>	<p>1: 10.3 ↓ 2: 9.1 ↑ 3: 9.9 ↖ 4: *10.7 ↖ 5: *10.6 ↖</p>		
Serie 48.0			
Total 330.0			

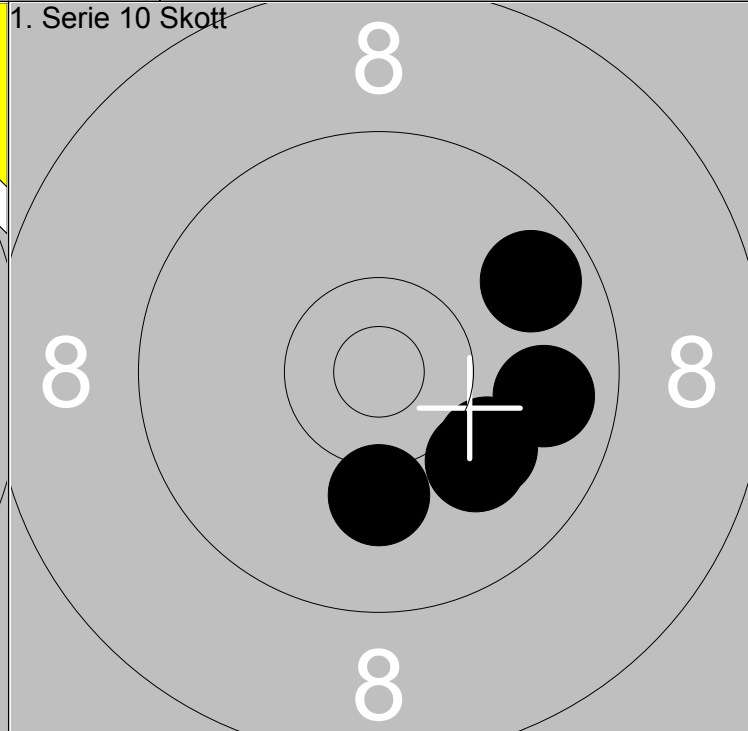
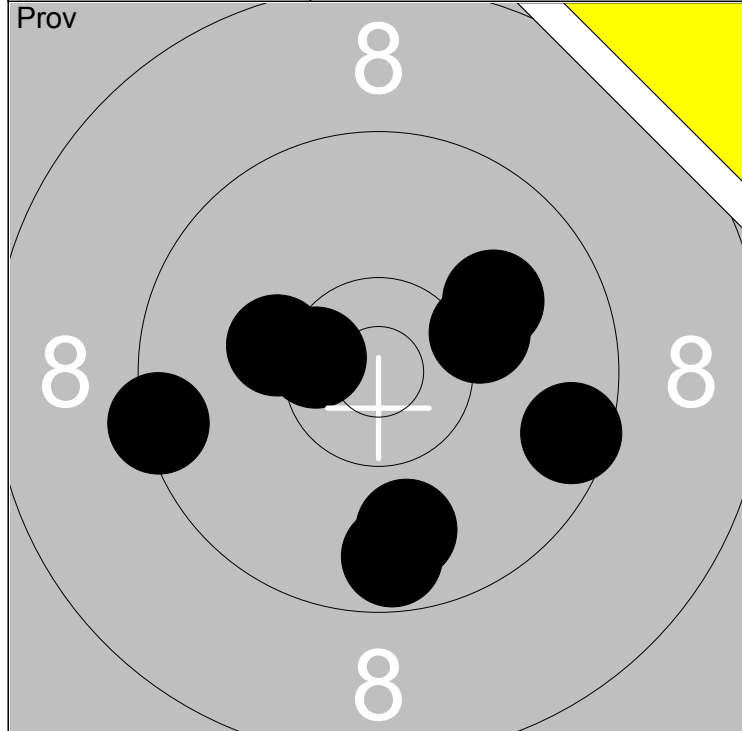

1: *10.5 ←	6: 10.2 →	Serie 76.0
2: 9.8 ↓	7: 10.2 ←	
3: 9.4 ←	8: 10.0 →	Total 185.0
4: 9.7 ↓		
5: 9.6 →		

1: 9.8 →	Serie 48.0
2: 10.0 ↘	
3: 9.7 ↗	Total 233.0
4: 10.0 ↘	
5: 10.1 ↓	

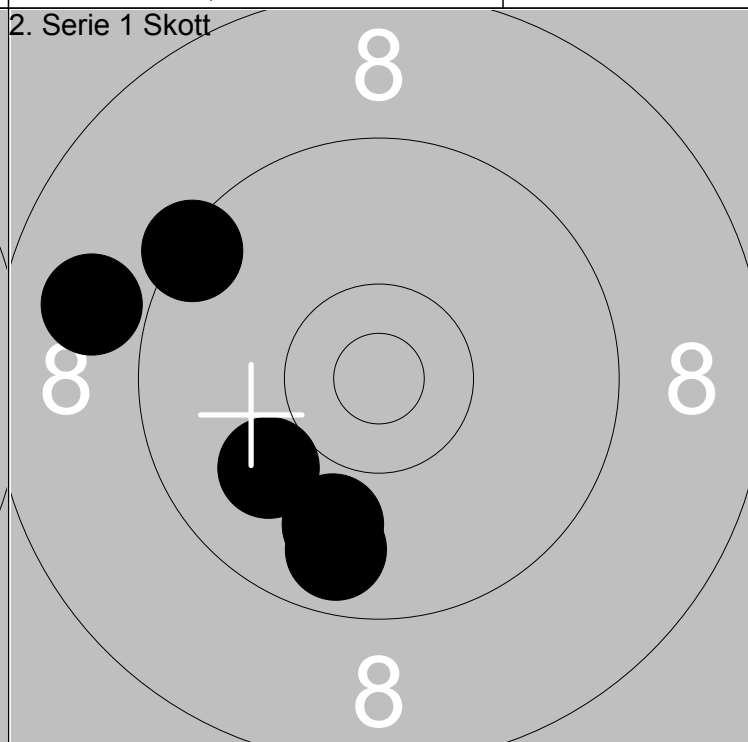
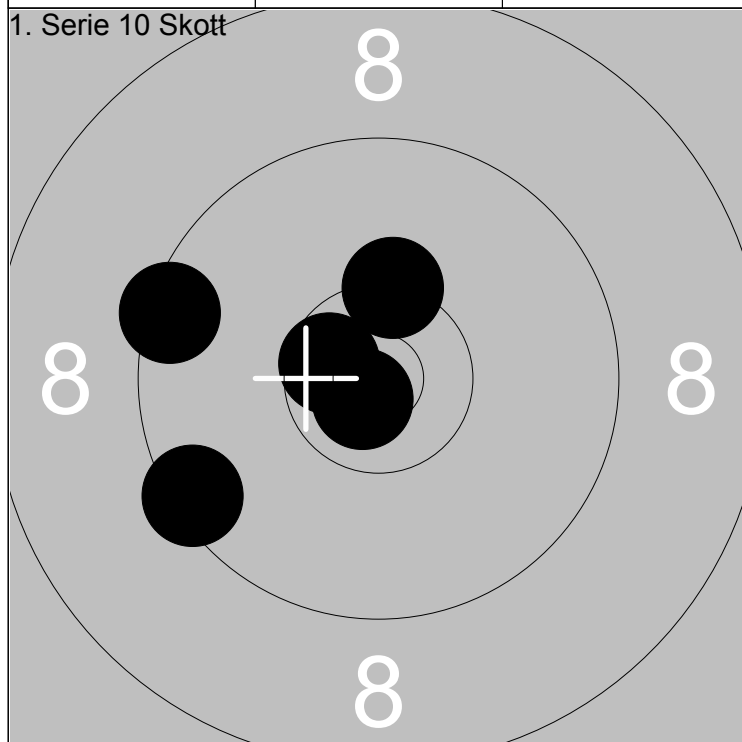

6: *10.3 ↑	Serie 48.0
7: 9.4 ←	
8: *10.6 ←	Total 281.0
9: *10.8 ↙	
10: 9.4 ←	

1: 9.7 ↓	Serie 45.0
2: 9.9 ↓	
3: 9.4 ←	Total 326.0
4: 8.9 ←	
5: 10.0 ↙	

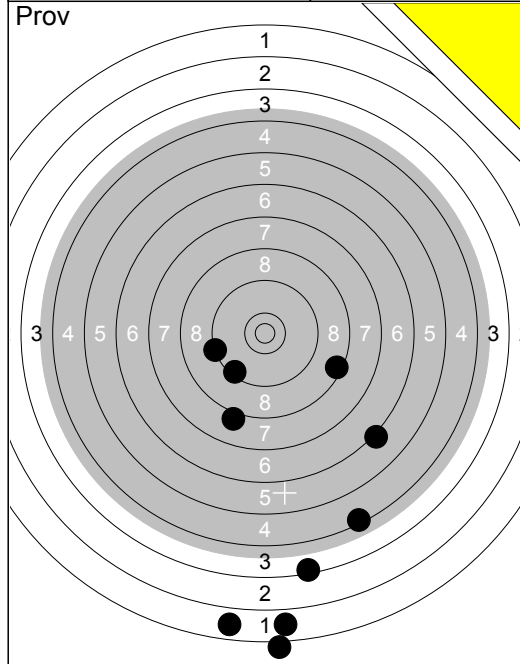

1:	8.1	↓
2:	1.8	↓
3:	3.4	↓
4:	1.1	↓
5:	1.8	↓
6:	6.2	↘
7:	4.4	↓
8:	8.5	→
9:	9.4	↙
10:	9.3	←
Serie		50.0
Total		144.0

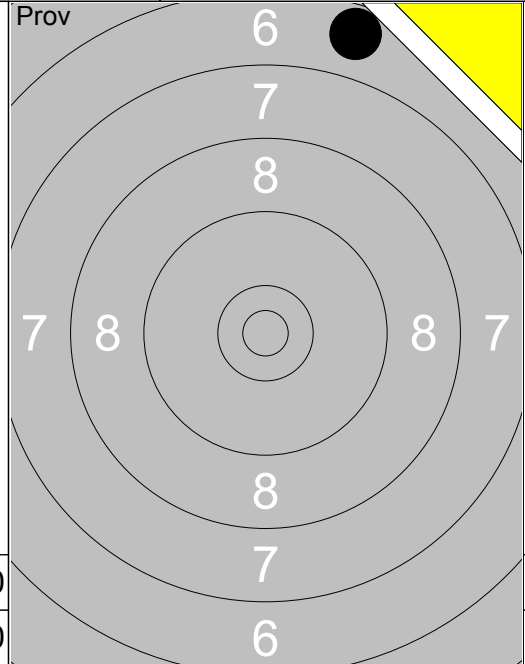

11:	6.7	↑
Serie		6.0
Total		144.0

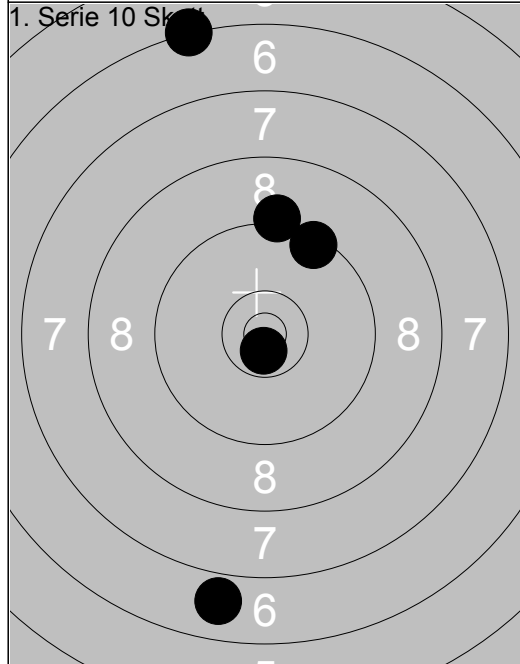

1:	6.3	↑
2:	9.2	↑
3:	6.9	↓
4:	9.4	↗
5:	*10.7	↓
Serie		40.0
Total		184.0

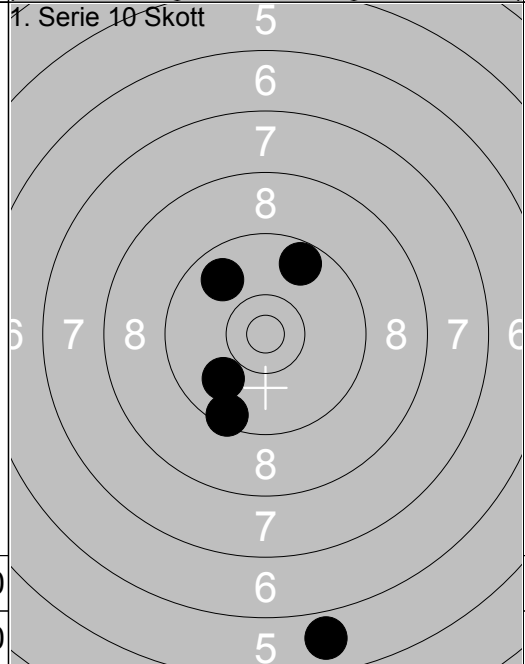

6:	5.9	↓
7:	9.8	↖
8:	9.5	↓
9:	9.7	↗
10:	9.9	↙
Serie		41.0
Total		225.0

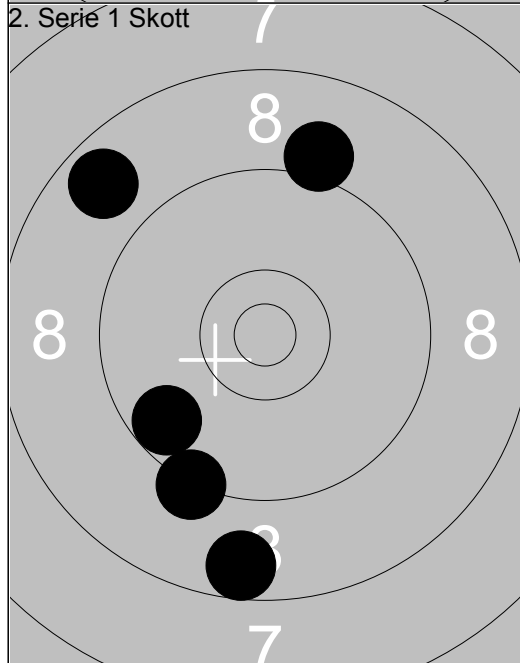

1:	8.6	↓
2:	9.1	↑
3:	9.7	↙
4:	8.7	↖
5:	9.3	↓
Serie		43.0
Total		268.0

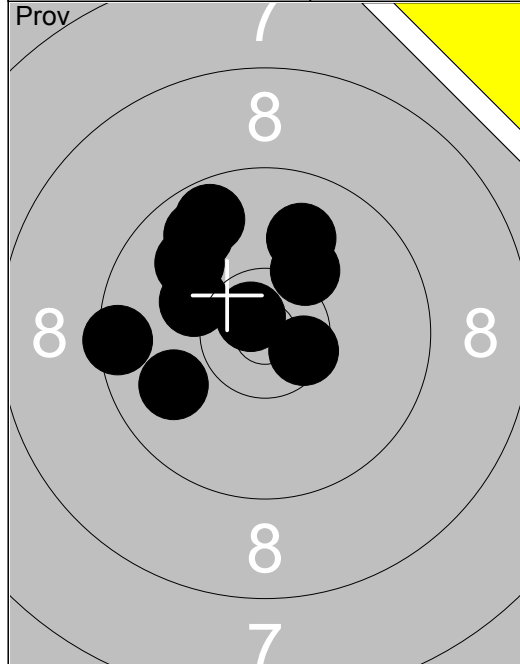

1:	*10.5	↘
2:	10.2	↗
3:	*10.7	↖
4:	10.2	↙
5:	9.5	←
6:	9.9	↗
7:	9.8	↖
8:	9.7	↗
9:	9.9	↙
10:	9.9	↖
Serie		94.0
Total		190.0

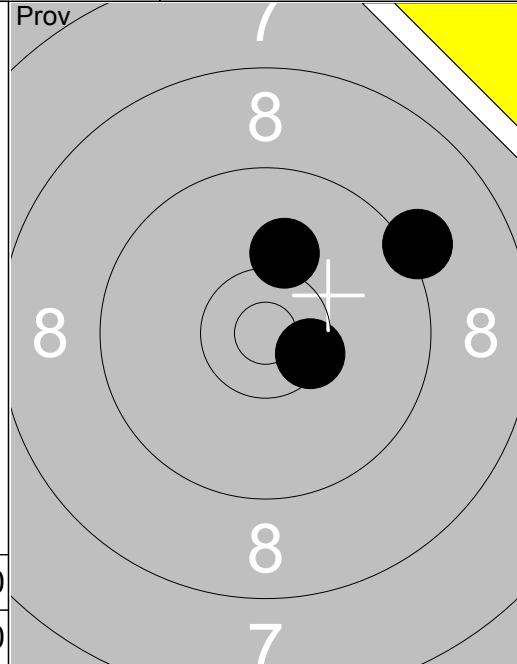

11:	10.1	↗
12:	*10.5	↘
13:	9.2	↗
Serie		29.0
Total		190.0

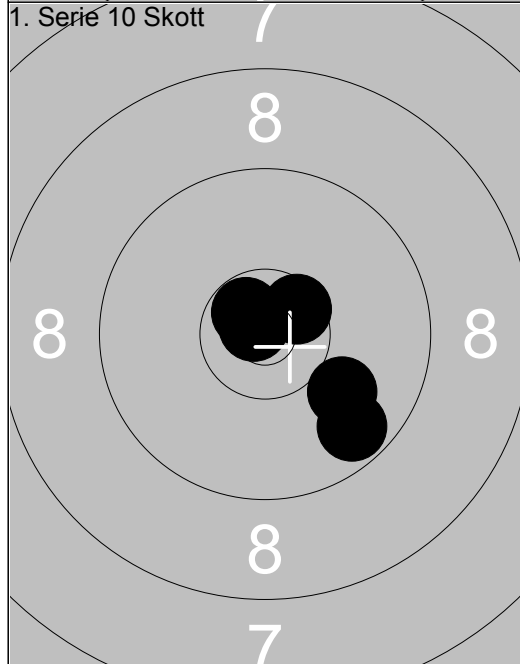

1:	9.7	↘
2:	10.0	↘
3:	*10.8	↖
4:	*10.7	↖
5:	*10.5	↗
Serie		49.0
Total		239.0

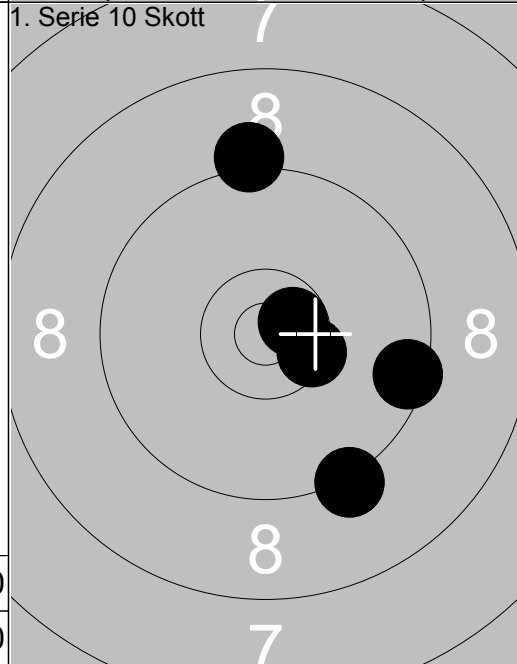

6:	9.2	↗
7:	*10.5	↘
8:	9.5	→
9:	*10.7	↗
10:	9.3	↘
Serie		47.0
Total		286.0

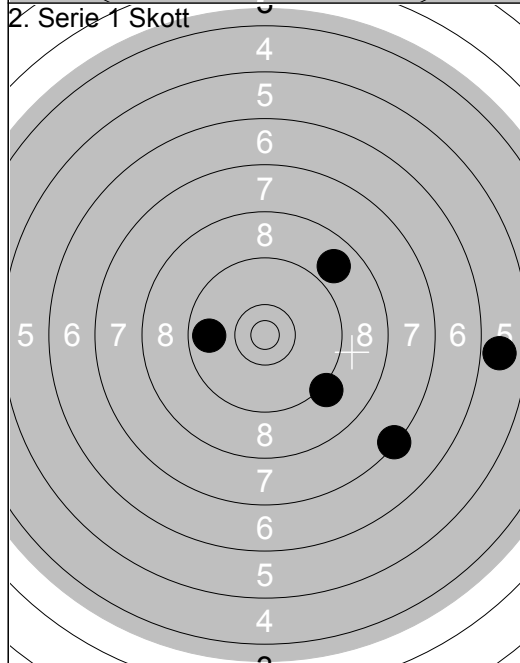

1:	9.7	←
2:	5.9	→
3:	9.2	↘
4:	7.3	↘
5:	8.9	↗
Serie		38.0
Total		324.0

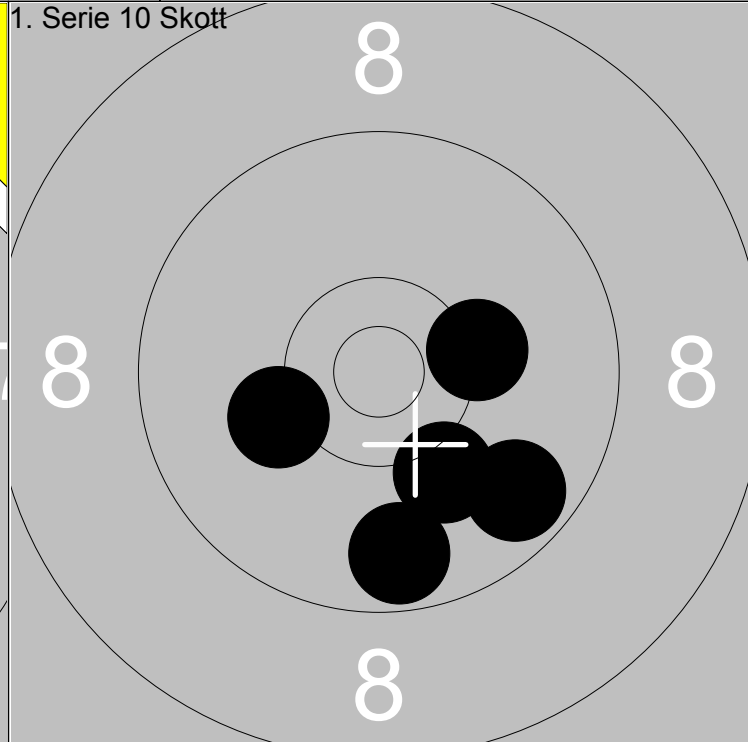
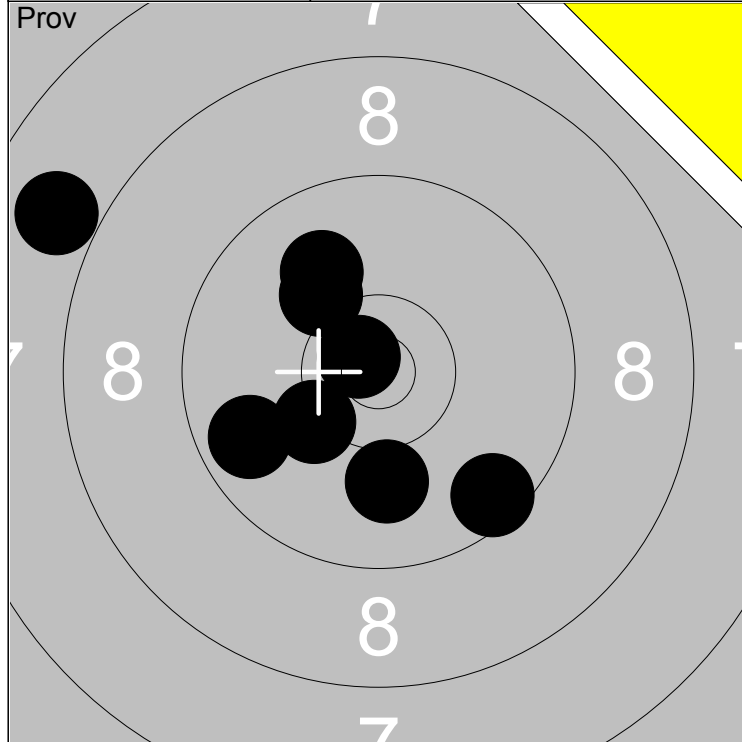

1: 7.9 ↙	6: 10.3 ↙	Serie	75.0
2: 10.0 ↗	7: *10.7 ↗		
3: 9.7 ↙	8: 9.5 ↘	Total	183.0
4: 10.1 ↗			
5: 10.0 ↓			

1: 10.2 ↙	Serie	48.0
2: 9.7 ↘		
3: 10.1 ↘	Total	231.0
4: 10.3 →		
5: 9.7 ↓		

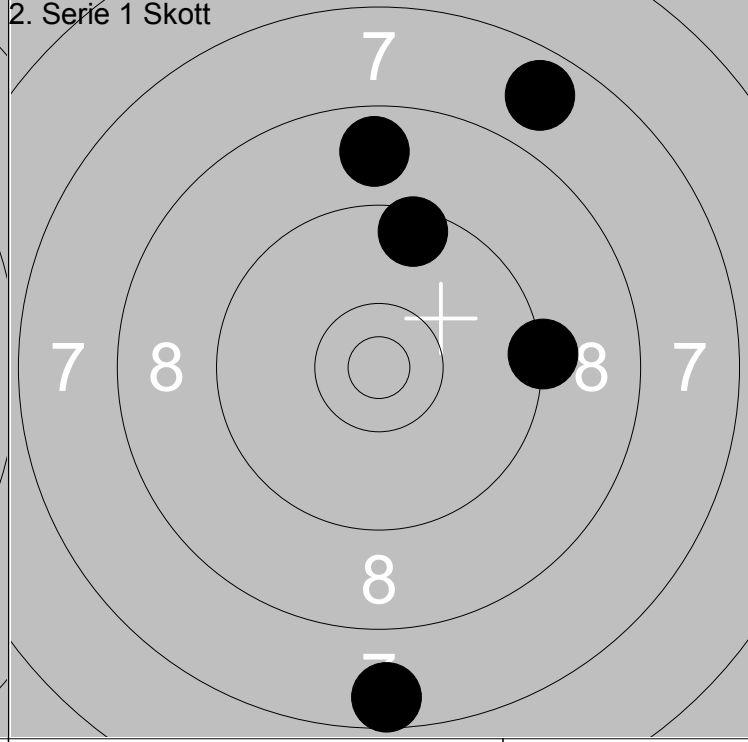
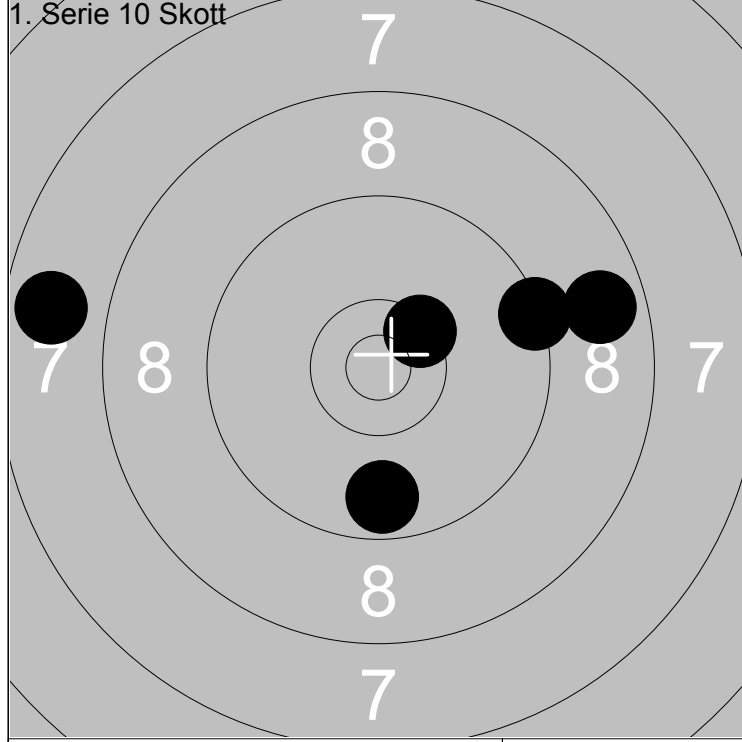

6: 9.4 →	Serie	43.0
7: 8.7 →		
8: 9.7 ↓	Total	274.0
9: 7.8 ↙		
10: *10.4 ↗		

1: 7.7 ↗	Serie	40.0
2: 8.8 ↑		
3: 7.6 ↓	Total	314.0
4: 9.5 ↑		
5: 9.3 →		

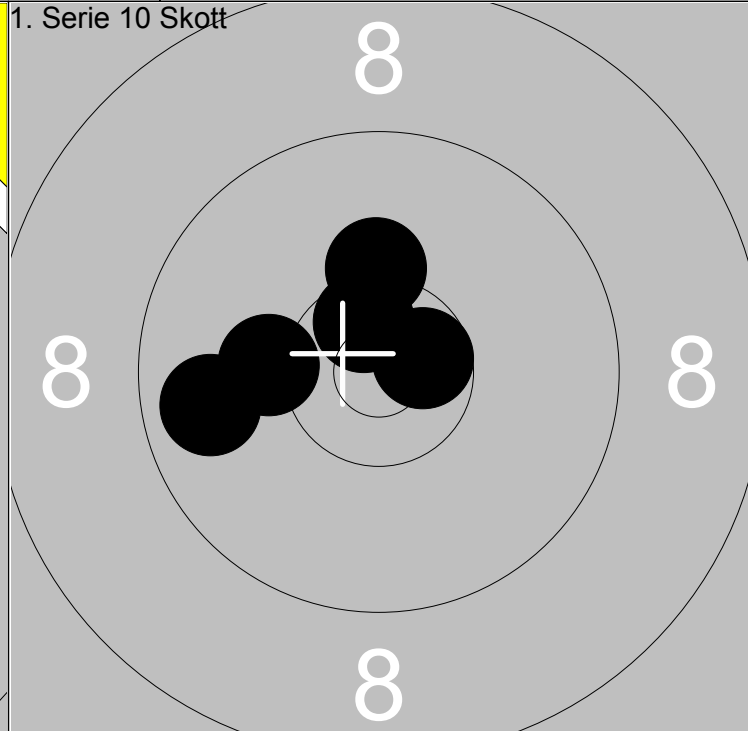
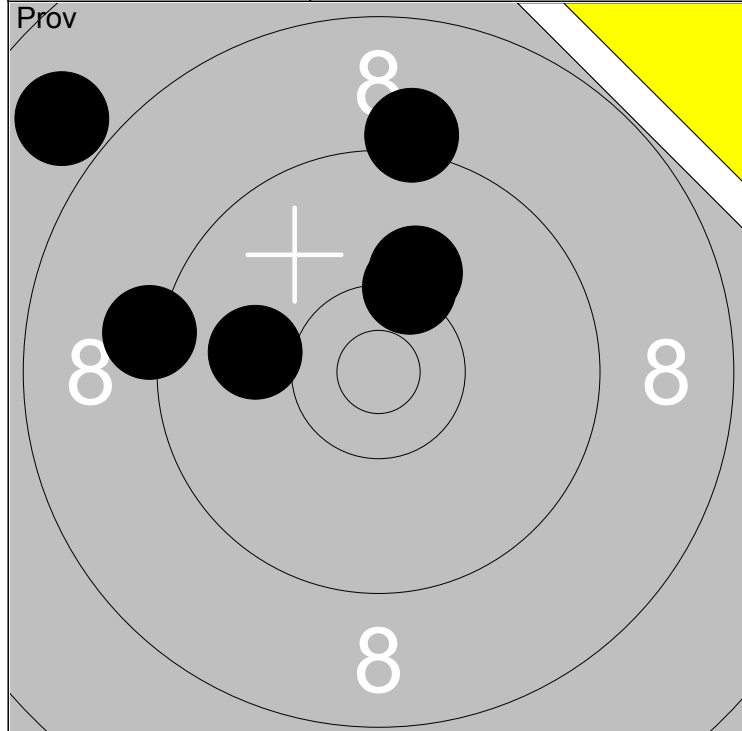

1: 10.0 ←	6: 10.3 ↗				
2: 9.2 ←		Serie	55.0		
3: 7.9 ↖					
4: 9.2 ↑		Total	179.0		
5: 10.2 ↗					

1: 10.2 ↑					
2: 10.2 ←		Serie	49.0		
3: *10.6 ↗					
4: *10.6 →		Total	228.0		
5: 9.8 ←					

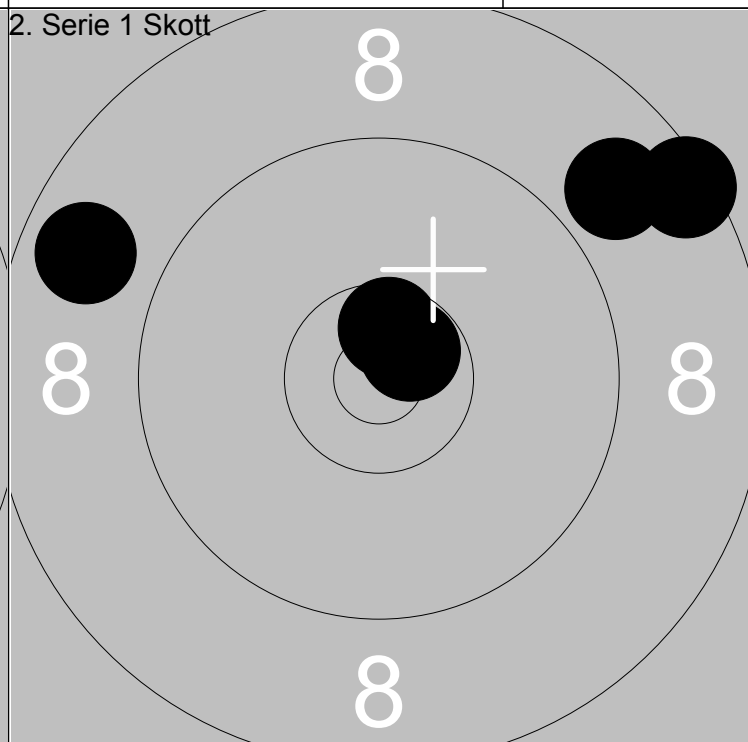
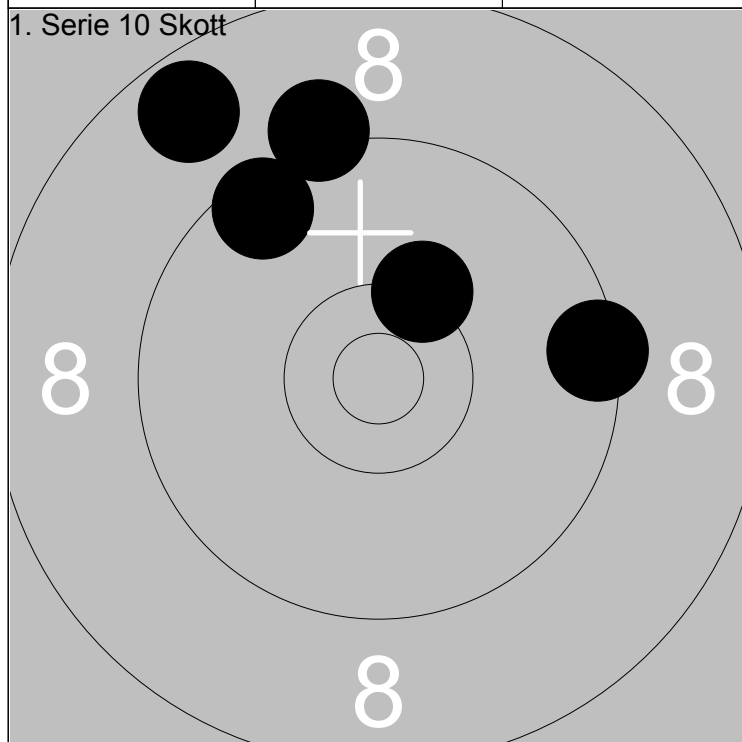

6: 8.7 ↖					
7: 10.3 ↗		Serie	45.0		
8: 9.5 ↖					
9: 9.4 →		Total	273.0		
10: 9.2 ↑					

1: 8.8 ↖					
2: 8.9 ↗		Serie	44.0		
3: 8.5 ↗					
4: *10.7 ↗		Total	317.0		
5: *10.6 ↗					

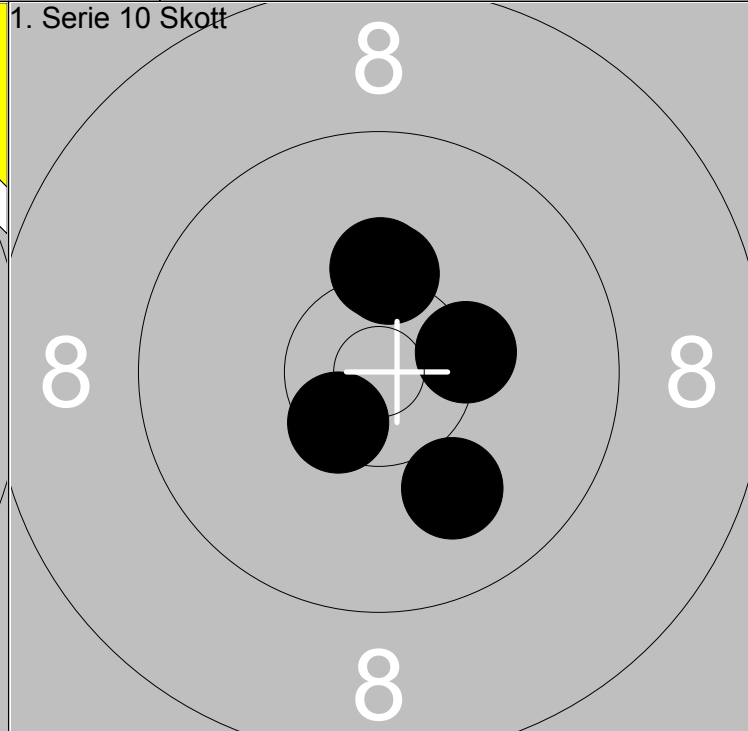
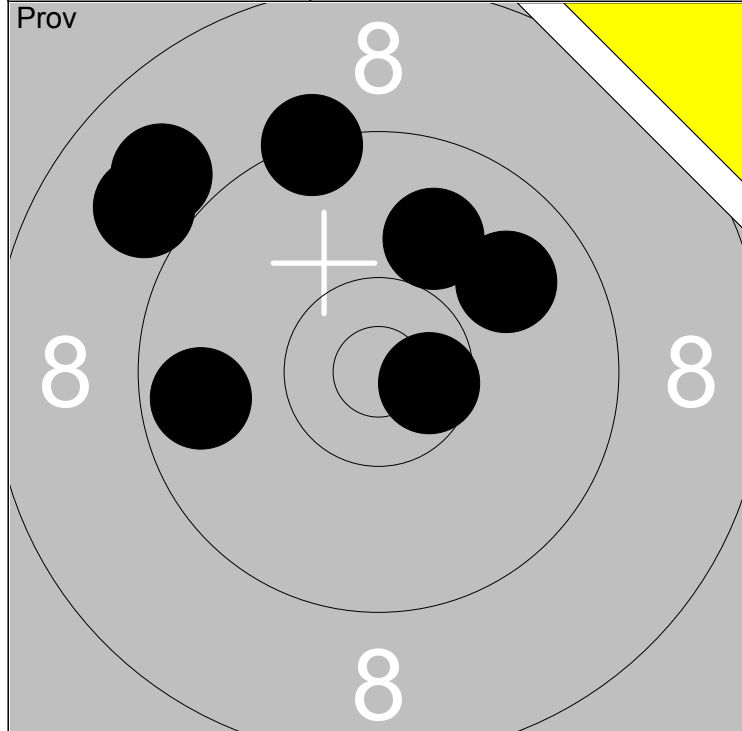

1: 9.3 ↑	6: 9.7 ←	Serie	64.0
2: *10.6 →	7: 9.9 ↗		
3: 9.0 ↖		Total	168.0
4: 8.9 ↖			
5: 10.0 ↑			

1: 10.3 ↑	Serie	50.0
2: 10.2 ↑		
3: *10.5 ↙	Total	218.0
4: *10.3 →		
5: 10.0 ↓		

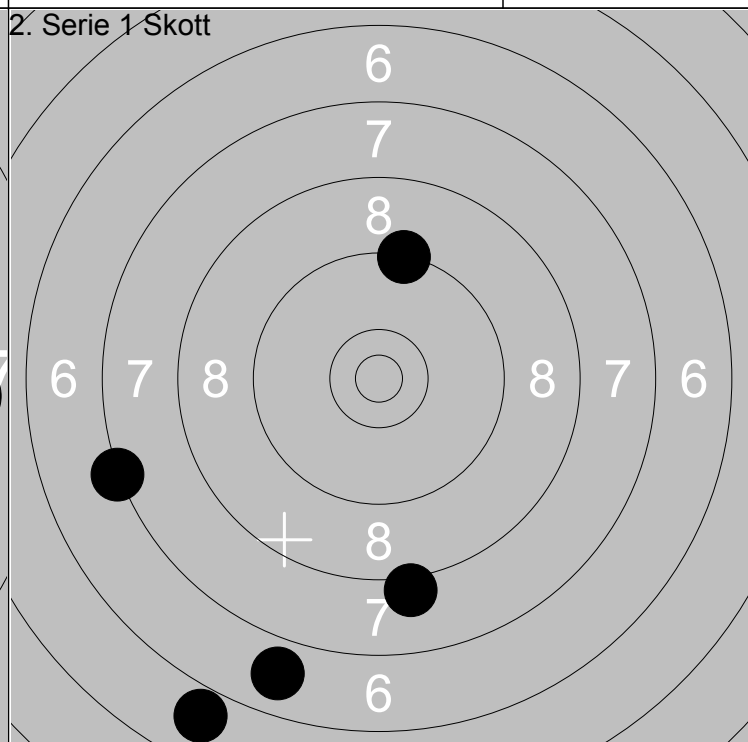
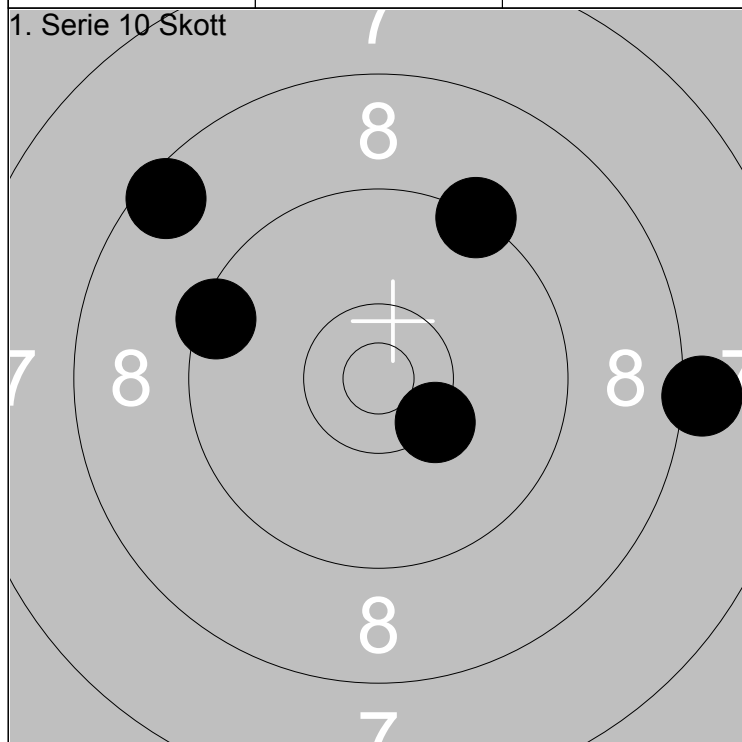

6: 9.3 ↗	Serie	44.0
7: *10.3 ↘		
8: 9.4 ↖	Total	262.0
9: 8.1 →		
10: 8.5 ↖		

1: 7.3 ←	Serie	35.0
2: 8.1 ↓		
3: 9.3 ↑	Total	297.0
4: 6.8 ↓		
5: 5.9 ↙		

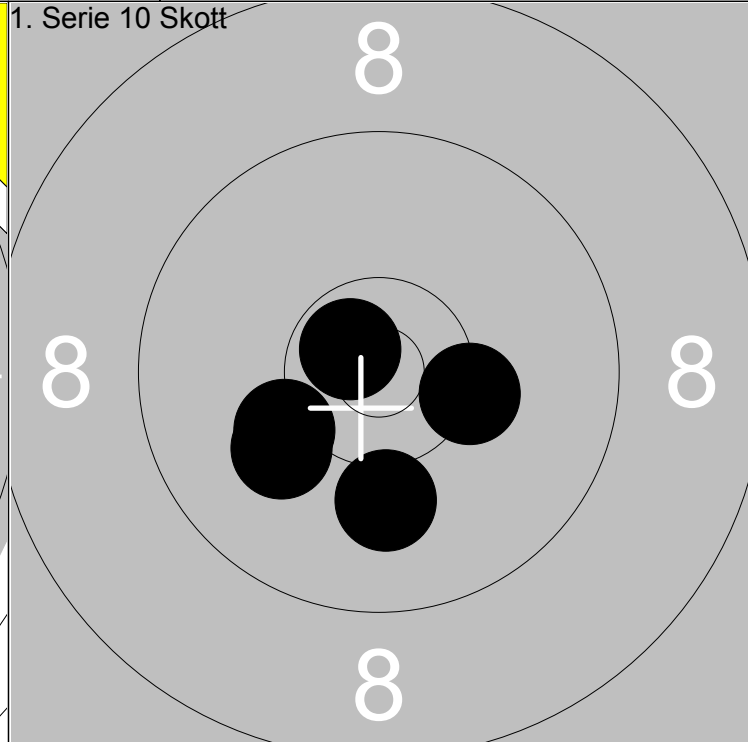
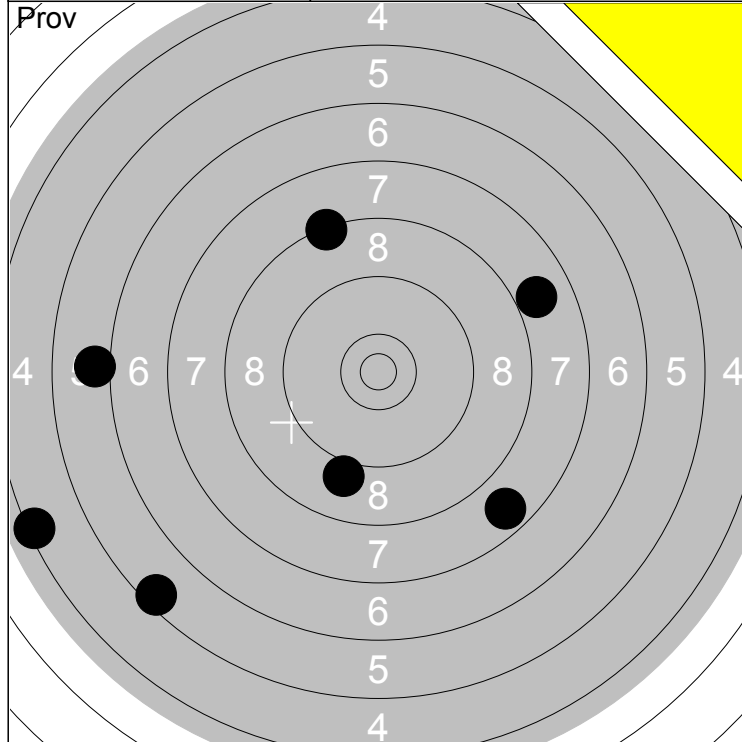

1: 6.0 ←	6: 8.3 ↗	Serie	46.0
2: 4.4 ↙	7: 7.7 ↘		
3: 7.9 ↗		Total	156.0
4: 5.5 ↙			
5: 9.1 ↓			

1: 10.1 ↙	Serie	50.0
2: 10.2 ↙		
3: 10.1 ↓	Total	206.0
4: *10.7 ↙		
5: *10.3 →		

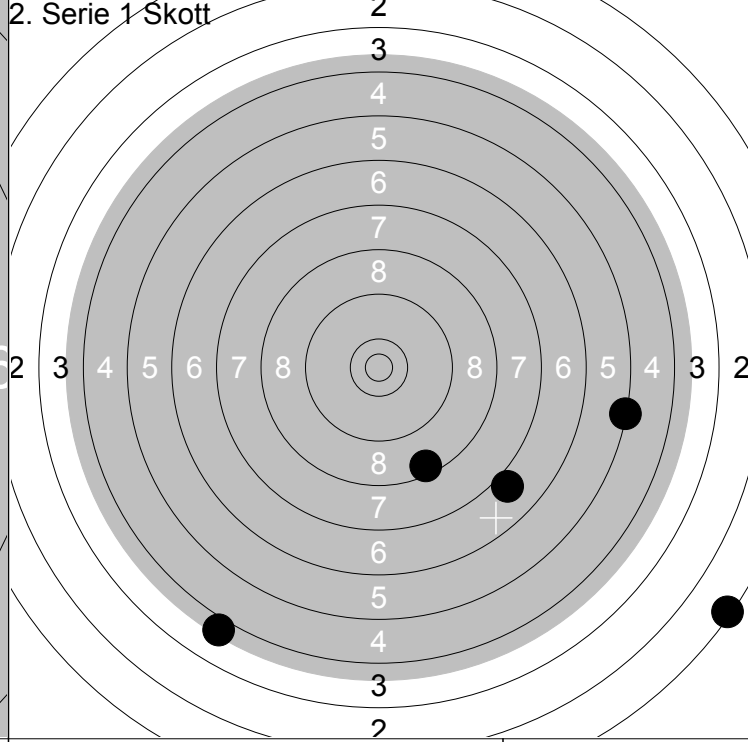
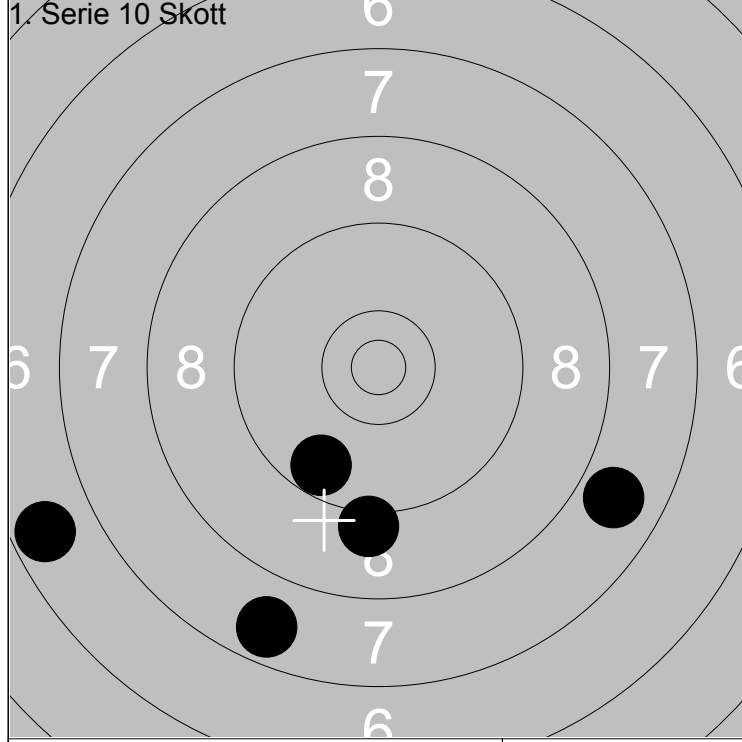

6: 7.7 ↓	Serie	38.0
7: 7.9 →		
8: 6.7 ←	Total	244.0
9: 9.1 ↓		
10: 9.7 ↓		

1: 5.3 →	Serie	25.0
2: 1.4 ↓		
3: 7.0 ↓	Total	269.0
4: 4.0 ↙		
5: 8.5 ↓		

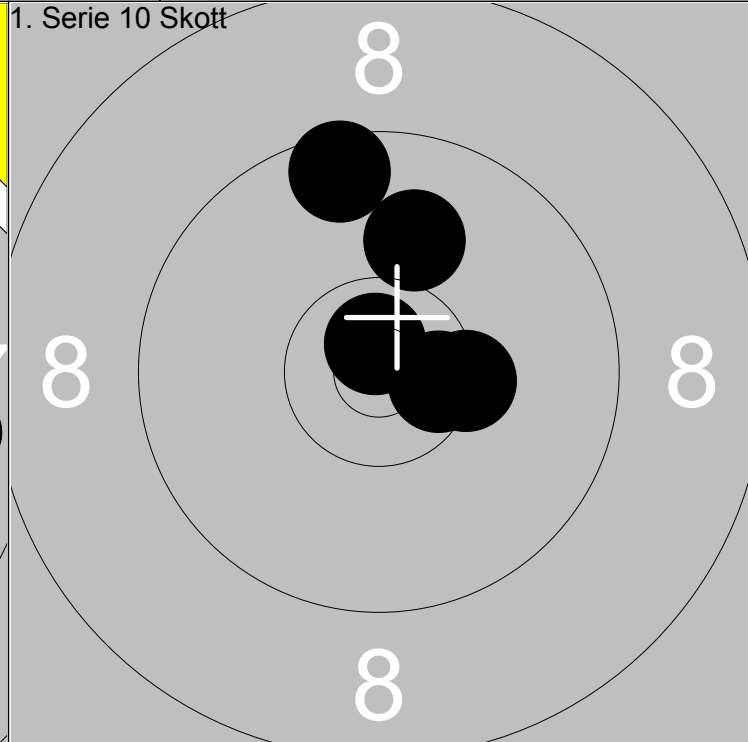
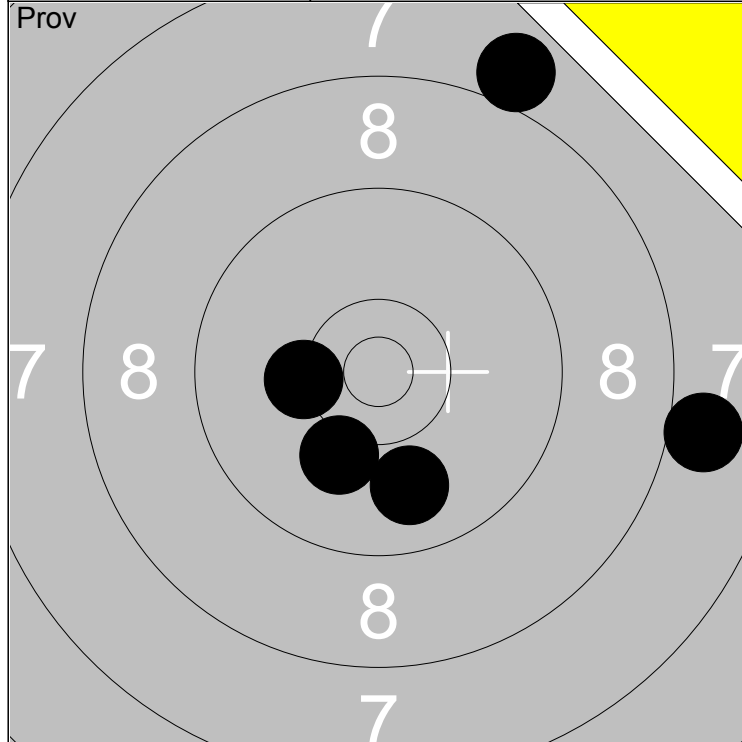

1: 9.9 ↓	Serie	45.0
2: 10.1 ↓		
3: 10.3 ←		
4: 8.0 →		
5: 8.0 ↑		
Total		147.0

1: 9.5 ↑	Serie	49.0
2: *10.5 →		
3: *10.3 →		
4: *10.8 ↑		
5: 10.0 ↑		
Total		196.0

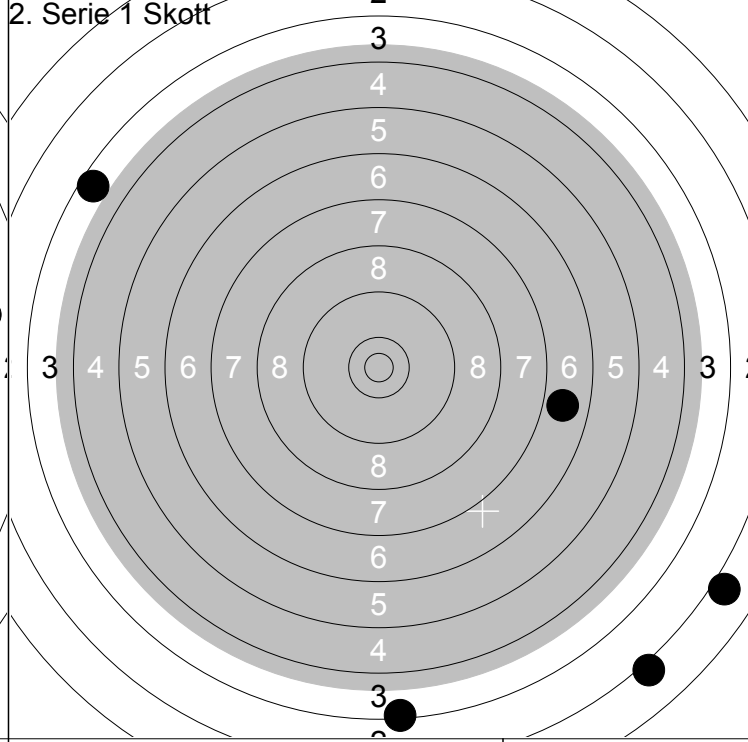
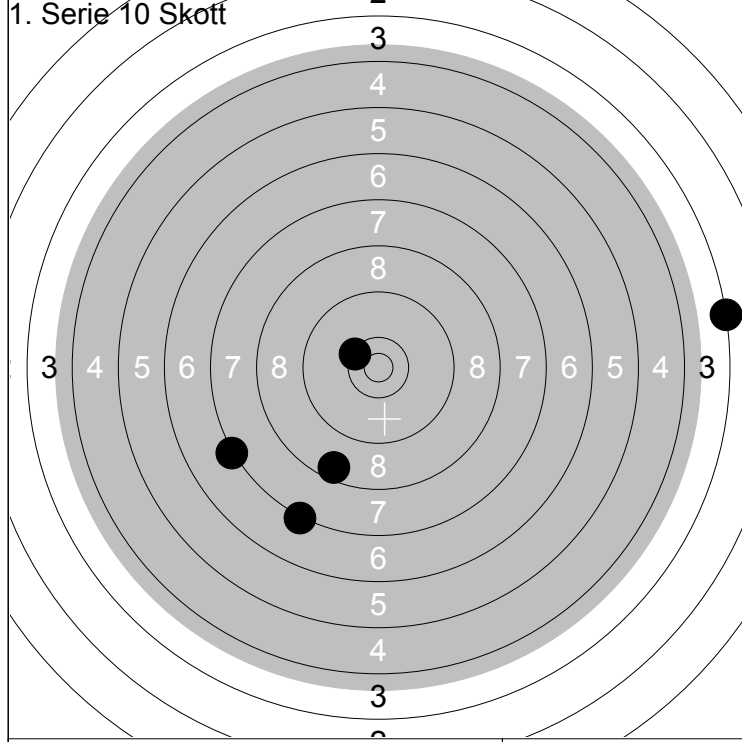

6: 8.6 ↓	Serie	35.0
7: 3.3 →		
8: 7.3 ←		
9: 7.3 ↓		
10: *10.4 ↖		
Total		231.0

1: 2.0 ↓	Serie	16.0
2: 3.6 ↗		
3: 3.4 ↓		
4: 2.1 ↓		
5: 6.9 →		
Total		247.0

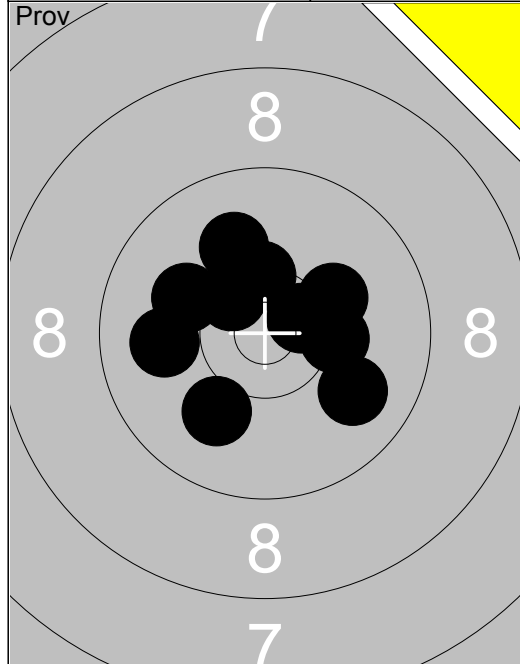

1:	9.9	←
2:	*10.4	↑
3:	10.0	↑
4:	*10.5	↖
5:	10.3	→
6:	*10.6	↗
7:	9.9	↘
8:	10.1	←
9:	10.2	↗
10:	10.0	↘
Serie		98.0
Total		159.0

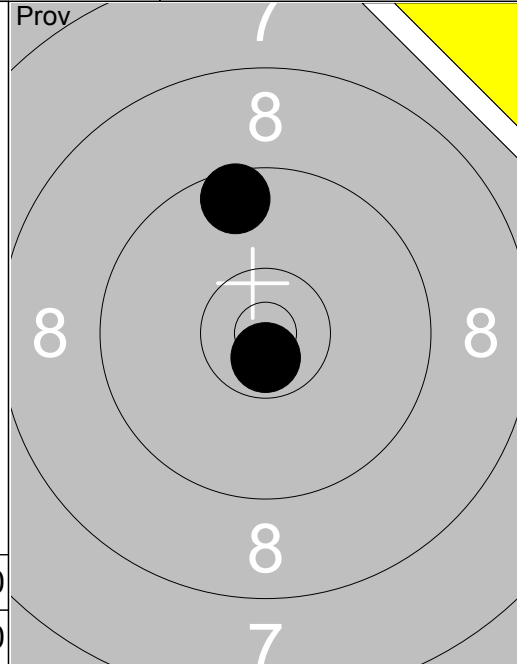

11:	9.6	↑
12:	*10.7	↘
Serie		19.0
Total		159.0

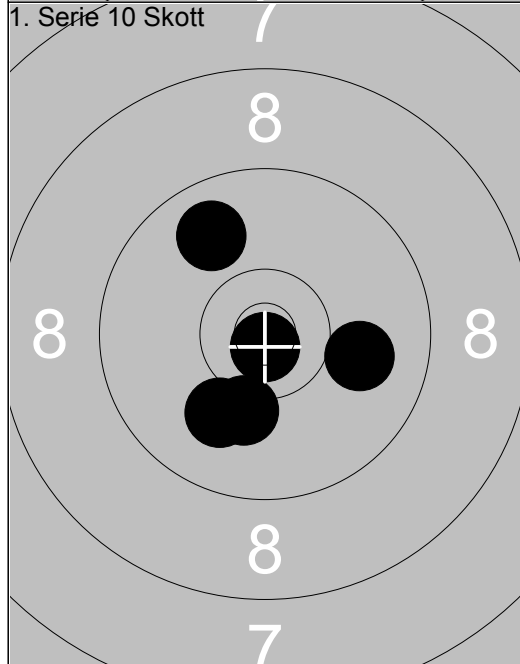

1:	9.8	↖
2:	10.2	↘
3:	10.0	→
4:	10.0	↘
5:	*10.8	↘
Serie		49.0
Total		208.0

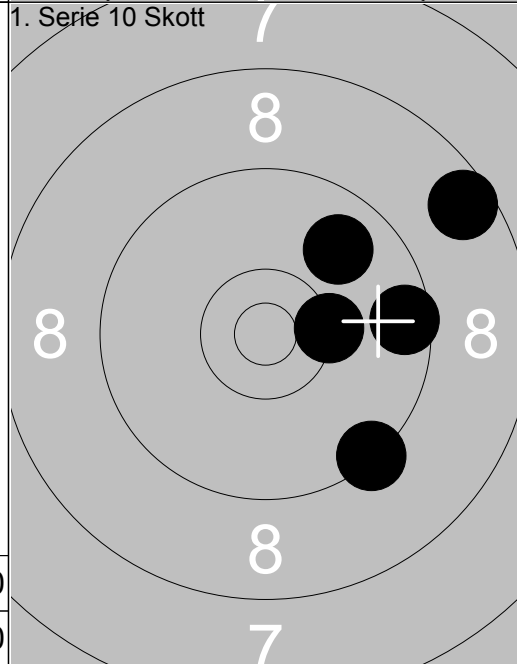

6:	9.6	→
7:	9.3	↘
8:	*10.3	→
9:	8.6	↗
10:	9.8	↗
Serie		45.0
Total		253.0

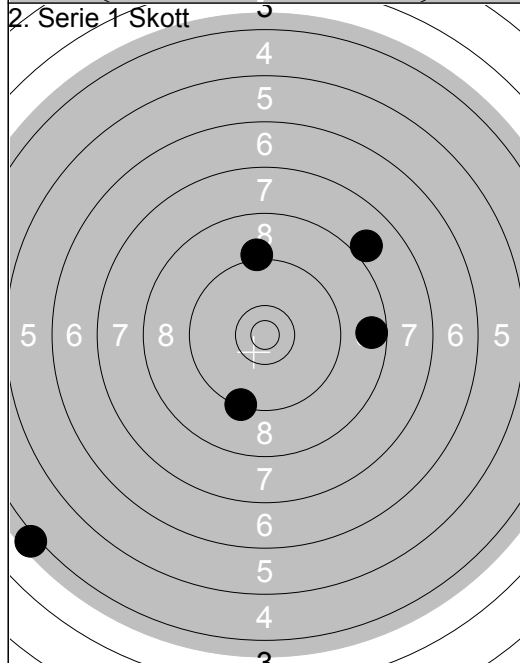

1:	4.1	↖
2:	8.0	↗
3:	9.3	↘
4:	8.6	→
5:	9.2	↑
Serie		38.0
Total		291.0

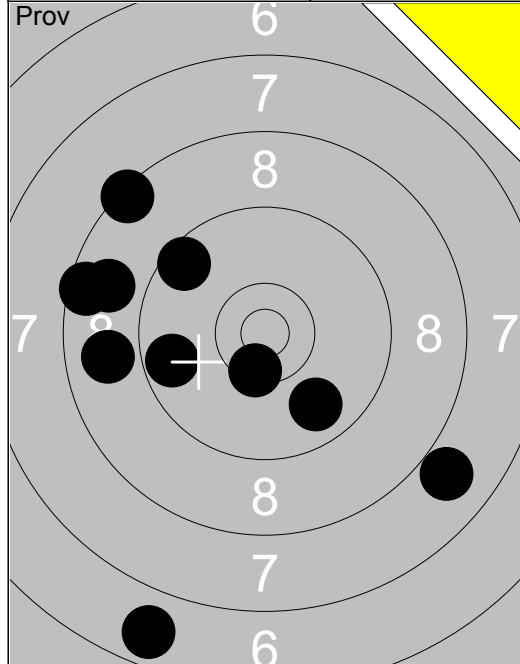

1: 9.8 ↘
2: 9.6 ↗
3: *10.4 ↘
4: 6.8 ↘
5: 8.4 ↗
6: 8.8 ←
7: 8.9 ←
8: 7.9 ↘
9: 9.7 ←
10: 8.5 ←
Serie 82.0
Total 143.0

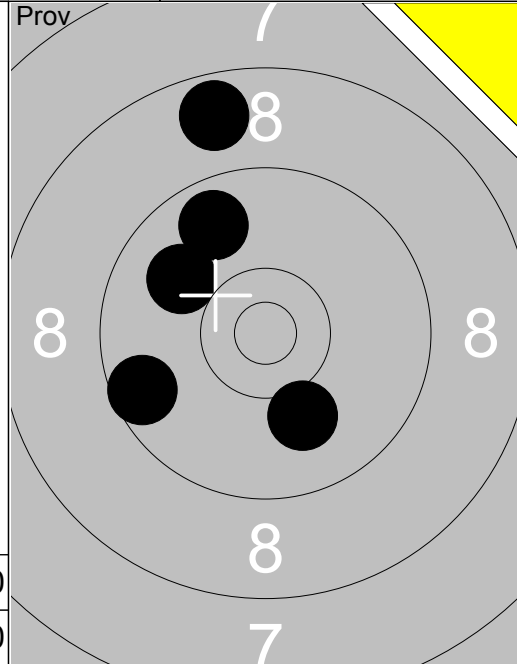

11: 10.0 ↘
12: 9.8 ↗
13: 9.6 ←
14: 10.1 ↘
15: 8.7 ↗
Serie 46.0
Total 143.0

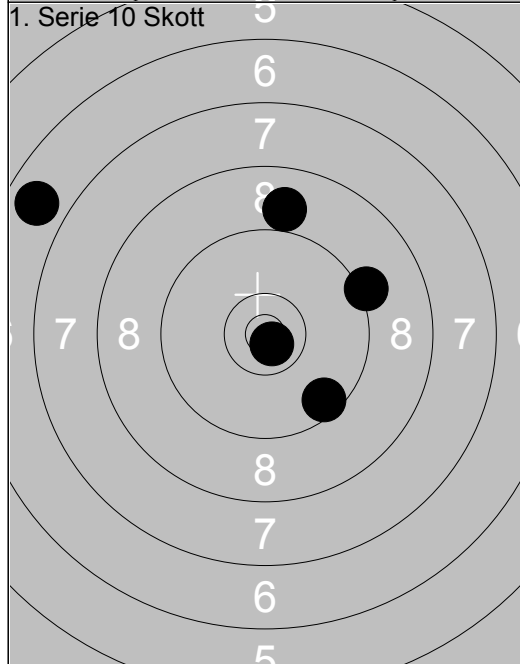

1: 6.8 ↗
2: 9.2 ↗
3: 9.0 ↗
4: 9.6 ↘
5: *10.8 ↘
Serie 43.0
Total 186.0

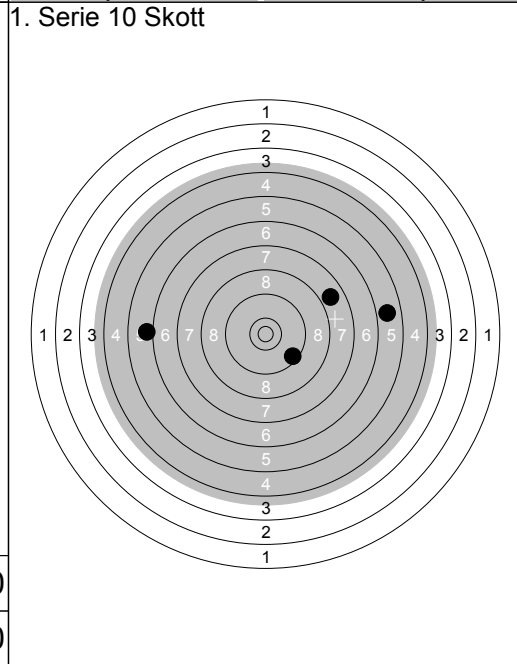

6: 0.0 →
7: 6.1 ←
8: 5.9 →
9: 7.9 ↗
10: 9.5 ↘
Serie 27.0
Total 213.0

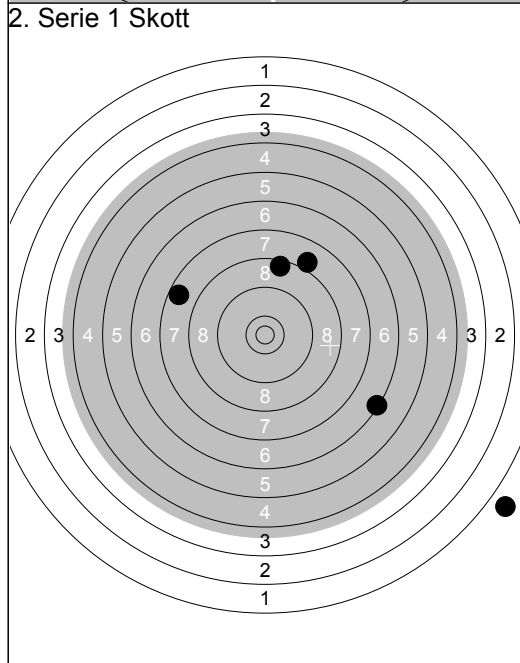

1: 6.4 ↘
2: 7.7 ↗
3: 0.0 ↘
4: 8.5 ↗
5: 8.0 ↗
Serie 29.0
Total 242.0