

1:	9.7	↓
2:	3.7	↑
3:	9.5	→
4:	*10.5	←
5:	8.7	↖
6:	*10.2	↘
7:	8.7	↙
8:	8.6	↑
9:	9.7	←
10:	*10.4	→
Serie		84.0
Total		0.0

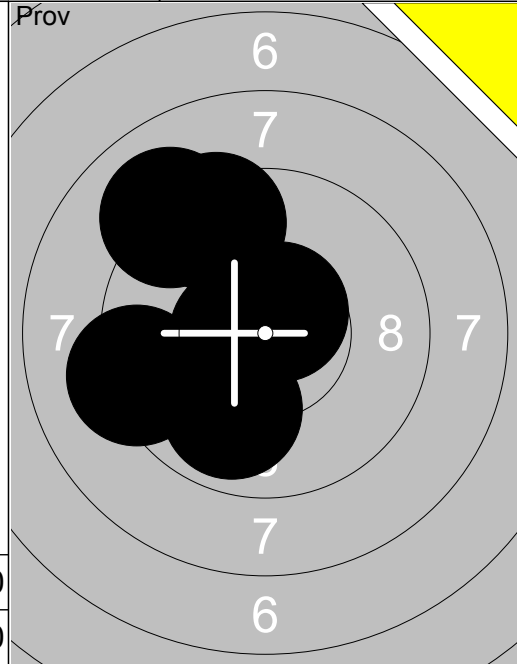

11:	9.9	↓
12:	9.2	↙
13:	9.4	↖
14:	*10.6	↗
15:	9.0	↖
16:	*10.6	←
Serie		56.0
Total		0.0

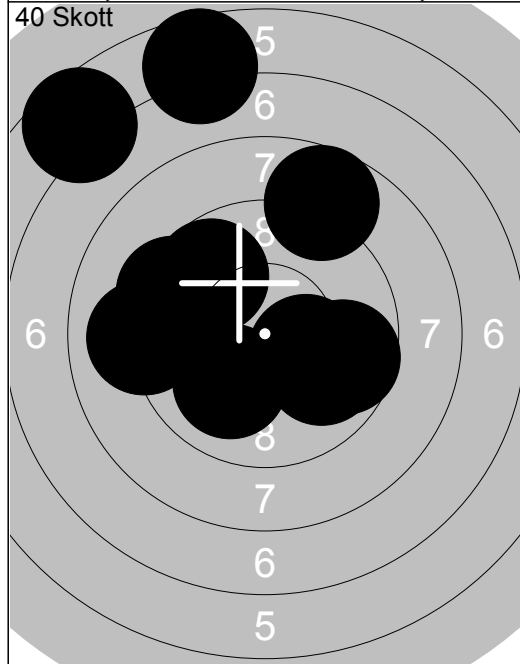

1:	9.1	←
2:	*10.2	→
3:	9.9	→
4:	9.4	↖
5:	10.0	↘
6:	9.7	→
7:	6.6	↖
8:	8.7	↑
9:	6.6	↑
10:	9.7	↖
Serie		85.0
Total		85.0

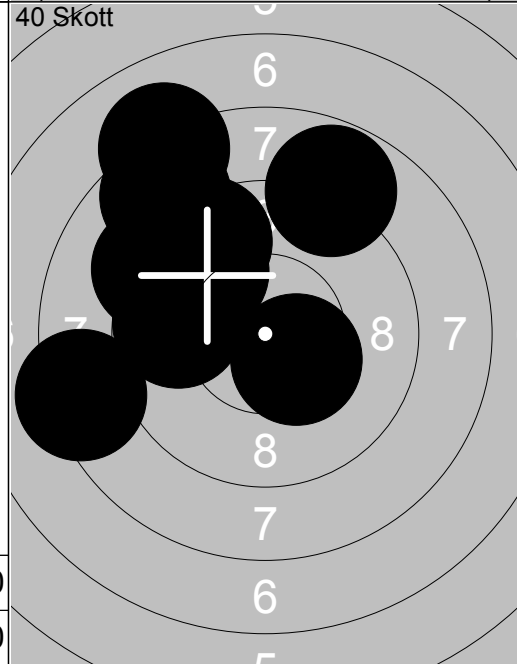

11:	*10.4	↘
12:	9.4	↖
13:	9.8	↖
14:	8.1	↖
15:	8.6	↖
16:	9.2	↙
17:	9.7	↖
18:	9.7	←
19:	8.8	↑
20:	8.3	←
Serie		87.0
Total		172.0

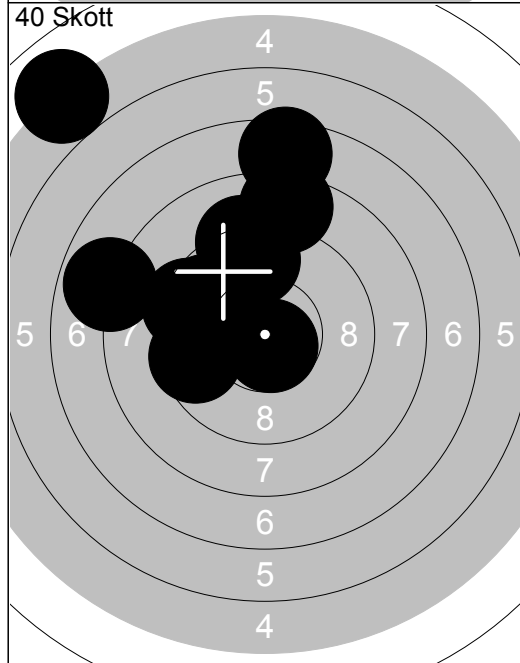

21:	9.4	←
22:	5.0	↖
23:	7.5	↑
24:	*10.7	↘
25:	7.8	←
26:	8.5	↑
27:	9.7	↙
28:	9.1	↑
29:	9.5	↑
30:	9.5	←
Serie		82.0
Total		254.0

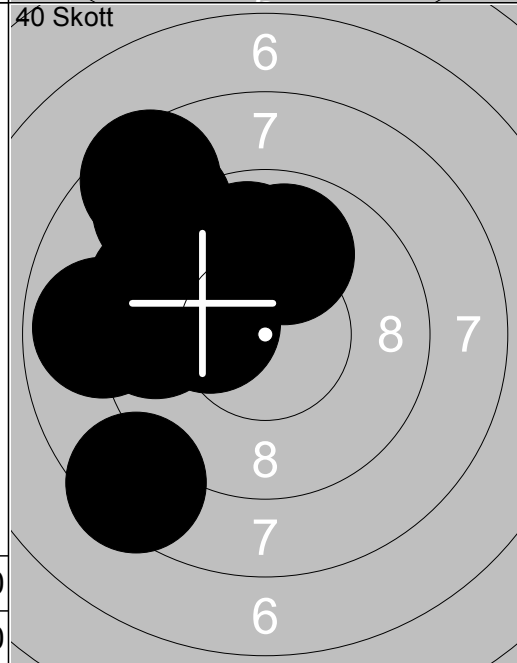



31:	8.9	↖
32:	9.9	↑
33:	*10.2	↘
34:	9.9	↑
35:	8.5	↖
36:	10.0	↙
37:	8.9	←
38:	9.5	←
39:	9.5	↙
40:	8.4	↘
Serie		88.0
Total		342.0

<p>Prov</p>	<p>1: 9.8 ↖                  2: 9.8 →                  3: 5.9 ←                  4: 9.6 ↑                  5: 10.1 ↓                  6: 10.1 ↗                  7: 9.2 →                  8: 9.0 ↑                  9: 8.6 →                  10: 9.1 ↘</p>	<p>Prov</p>	<p>11: 9.3 ←                  12: *10.6 ↖                  13: *10.3 →                  14: 8.0 ↘                  15: *10.3 ↖                  16: 8.5 ←                  17: *10.2 ↘                  18: *10.3 →</p>
Serie 87.0		Serie 75.0	
Total 0.0		Total 0.0	

<p>40 Skott</p>	<p>1: 8.6 ↓                  2: 9.1 ↑                  3: 9.6 ←                  4: *10.4 ↘                  5: 9.7 ↓                  6: *10.5 ↖                  7: 9.4 ↖                  8: 8.4 ←                  9: 9.8 ↖                  10: *10.5 ↗</p>	<p>40 Skott</p>	<p>11: 9.6 ↓                  12: 8.6 →                  13: *10.3 ↓                  14: 8.8 ←                  15: 8.6 ←                  16: *10.3 ↗                  17: 9.9 ↓                  18: 9.4 ←                  19: 10.1 →                  20: 10.0 ↗</p>
Serie 91.0		Serie 91.0	
Total 91.0		Total 182.0	

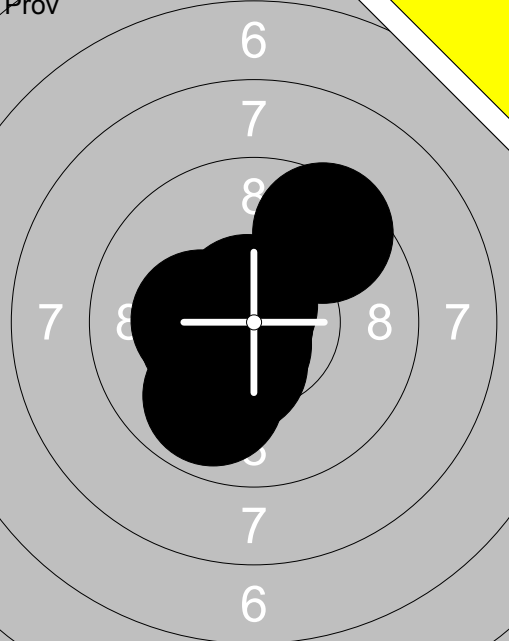
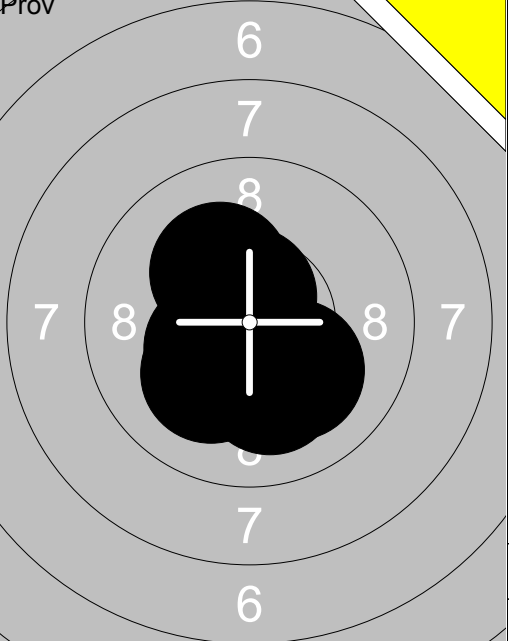
<p>40 Skott</p>	<p>21: *10.2 ↖                  22: 9.9 ↖                  23: *10.2 ↓                  24: *10.8 ↖                  25: 9.8 ↑                  26: 9.3 ↖                  27: 9.5 ↗                  28: *10.7 ↖                  29: *10.7 ↓                  30: *10.5 ↓</p>	<p>40 Skott</p>	<p>31: 10.1 →                  32: *10.3 ↗                  33: *10.6 ↖                  34: *10.3 →                  35: *10.8 ↖                  36: *10.2 ↖                  37: 9.7 ←                  38: 9.7 ←                  39: *10.4 ↖                  40: *10.7 →</p>
Serie 96.0		Serie 98.0	
Total 278.0		Total 376.0	

Prov 	1: *10.4 ↙ 2: *10.4 ↓ 3: *10.3 ↙ 4: *10.3 ↓ 5: *10.6 ← 6: *10.7 ↗ 7: *10.8 ← 8: *10.6 ↓ 9: 9.9 ↓ 10: 9.5 ↗ <hr/> Serie 98.0 Total 0.0	Prov 	11: *10.4 ↓ 12: *10.2 ↗ 13: 10.1 ↓ 14: 10.1 ↓ 15: *10.4 ↙ 16: 10.1 ↓ 17: *10.6 ↗ <hr/> Serie 70.0 Total 0.0
--	--	--	---

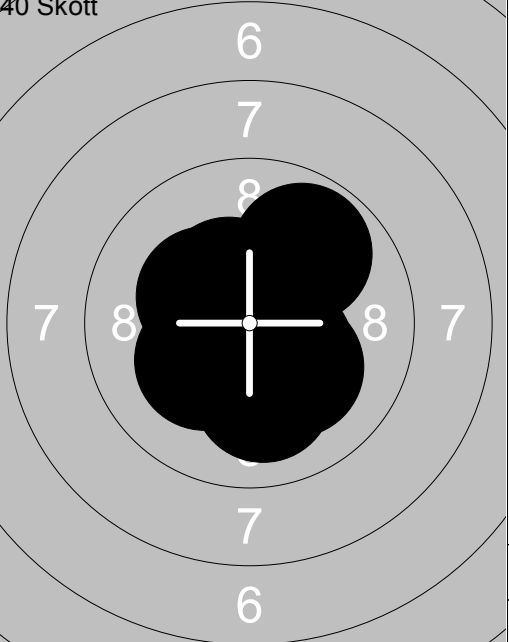
40 Skott 	1: *10.8 ← 2: *10.4 ↓ 3: *10.3 ↓ 4: 9.5 ↓ 5: *10.7 ↗ 6: 9.4 ← 7: *10.2 ↗ 8: 9.6 ↓ 9: *10.2 ↗ 10: *10.3 ↓ <hr/> Serie 97.0 Total 97.0	40 Skott 	11: *10.3 ↗ 12: *10.4 ↗ 13: *10.2 ↓ 14: *10.8 ← 15: *10.4 ↓ 16: *10.7 ↗ 17: 10.1 ↓ 18: *10.2 ↙ 19: *10.4 ↓ 20: 9.8 ↗ <hr/> Serie 99.0 Total 196.0
---	---	---	--

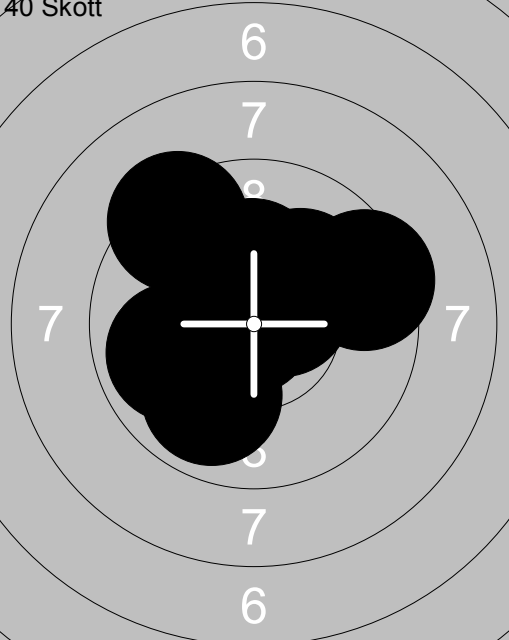
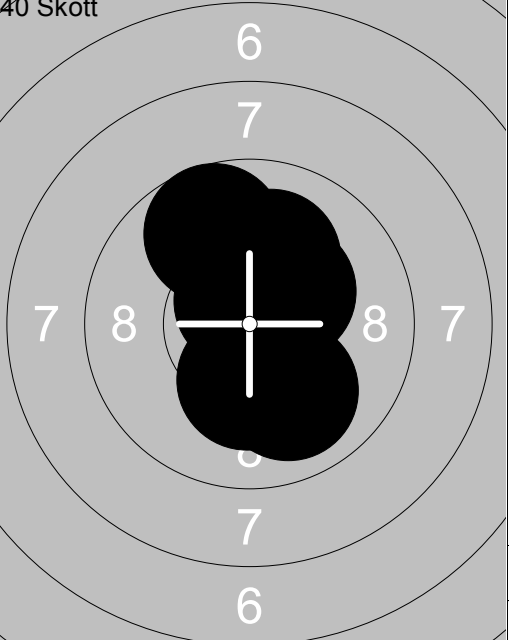
40 Skott 	21: *10.2 ↑ 22: *10.8 ← 23: 9.3 ↗ 24: 9.9 ← 25: 9.4 → 26: 9.9 ↓ 27: 10.1 ↗ 28: *10.5 ↗ 29: *10.5 ← 30: *10.6 ← <hr/> Serie 96.0 Total 292.0	40 Skott 	31: *10.2 ↑ 32: *10.3 ↗ 33: 9.7 ↗ 34: *10.5 ↗ 35: 10.0 ↓ 36: 10.1 ↗ 37: *10.7 ↓ 38: *10.5 ↗ 39: *10.2 ↓ 40: *10.6 ↗ <hr/> Serie 99.0 Total 391.0
--	--	--	---

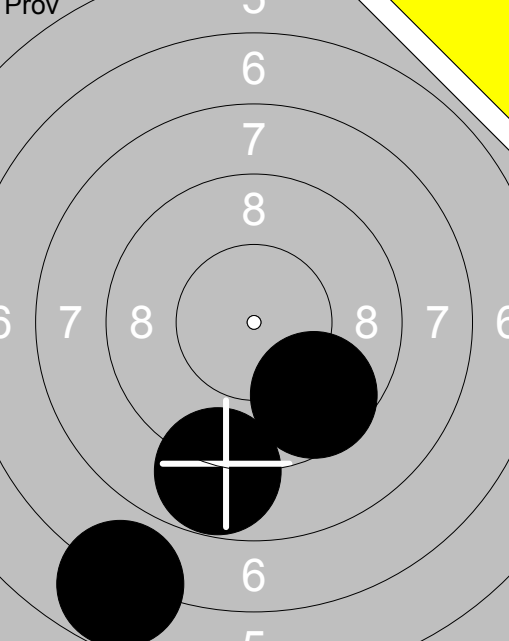
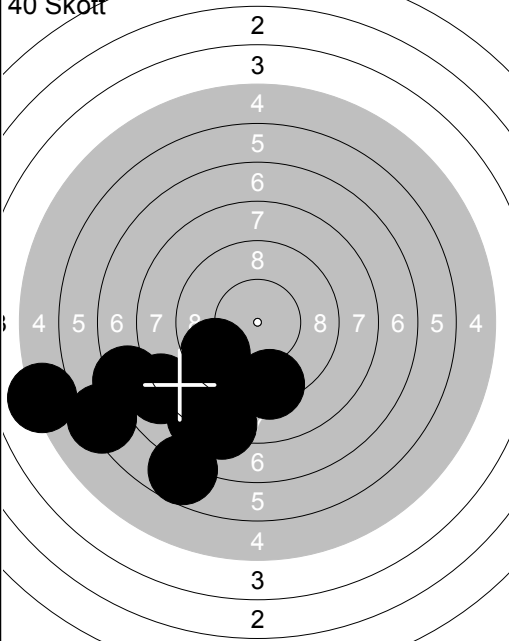
<p>Prov</p> 	<p>40 Skott</p> 	<table style="width:100%; border-collapse: collapse;"> <tr><td>1: 8.1 ↘</td></tr> <tr><td>2: 9.5 ↘</td></tr> <tr><td>3: 6.3 ↘</td></tr> <tr><td>4: 8.2 ↘</td></tr> <tr><td>5: 5.1 ←</td></tr> <tr><td>6: 9.3 ↓</td></tr> <tr><td>7: 7.3 ←</td></tr> <tr><td>8: 6.7 ↘</td></tr> <tr><td>9: 7.9 ←</td></tr> <tr><td>10: 9.6 ↘</td></tr> </table> <table style="width:100%; border-collapse: collapse; margin-top: 5px;"> <tr><td style="text-align: right;">Serie</td><td style="text-align: right;">74.0</td></tr> <tr><td style="text-align: right;">Total</td><td style="text-align: right;">74.0</td></tr> </table>	1: 8.1 ↘	2: 9.5 ↘	3: 6.3 ↘	4: 8.2 ↘	5: 5.1 ←	6: 9.3 ↓	7: 7.3 ←	8: 6.7 ↘	9: 7.9 ←	10: 9.6 ↘	Serie	74.0	Total	74.0
1: 8.1 ↘																
2: 9.5 ↘																
3: 6.3 ↘																
4: 8.2 ↘																
5: 5.1 ←																
6: 9.3 ↓																
7: 7.3 ←																
8: 6.7 ↘																
9: 7.9 ←																
10: 9.6 ↘																
Serie	74.0															
Total	74.0															
<table style="width:100%; border-collapse: collapse; margin-top: 5px;"> <tr><td style="text-align: right;">Serie</td><td style="text-align: right;">23.0</td></tr> <tr><td style="text-align: right;">Total</td><td style="text-align: right;">0.0</td></tr> </table>	Serie	23.0	Total	0.0	<table style="width:100%; border-collapse: collapse; margin-top: 5px;"> <tr><td style="text-align: right;">Serie</td><td style="text-align: right;">23.0</td></tr> <tr><td style="text-align: right;">Total</td><td style="text-align: right;">0.0</td></tr> </table>	Serie	23.0	Total	0.0	<table style="width:100%; border-collapse: collapse; margin-top: 5px;"> <tr><td style="text-align: right;">Serie</td><td style="text-align: right;">74.0</td></tr> <tr><td style="text-align: right;">Total</td><td style="text-align: right;">74.0</td></tr> </table>	Serie	74.0	Total	74.0		
Serie	23.0															
Total	0.0															
Serie	23.0															
Total	0.0															
Serie	74.0															
Total	74.0															

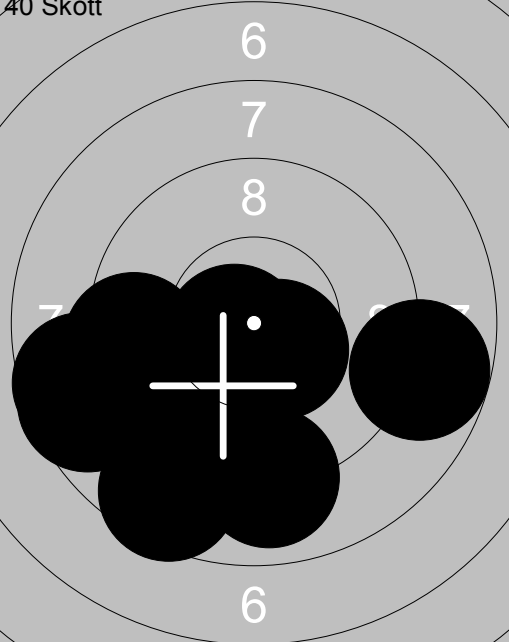
<p>40 Skott</p> 	<p>40 Skott</p> 	<table style="width:100%; border-collapse: collapse;"> <tr><td>11: 8.6 ←</td></tr> <tr><td>12: 9.4 ←</td></tr> <tr><td>13: 8.8 →</td></tr> <tr><td>14: 9.5 ←</td></tr> <tr><td>15: *10.7 ↘</td></tr> <tr><td>16: 8.6 ←</td></tr> <tr><td>17: 9.0 ↓</td></tr> <tr><td>18: *10.5 ↘</td></tr> <tr><td>19: 9.8 ↘</td></tr> <tr><td>20: 8.5 ↘</td></tr> </table> <table style="width:100%; border-collapse: collapse; margin-top: 5px;"> <tr><td style="text-align: right;">Serie</td><td style="text-align: right;">88.0</td></tr> <tr><td style="text-align: right;">Total</td><td style="text-align: right;">162.0</td></tr> </table>	11: 8.6 ←	12: 9.4 ←	13: 8.8 →	14: 9.5 ←	15: *10.7 ↘	16: 8.6 ←	17: 9.0 ↓	18: *10.5 ↘	19: 9.8 ↘	20: 8.5 ↘	Serie	88.0	Total	162.0								
11: 8.6 ←																								
12: 9.4 ←																								
13: 8.8 →																								
14: 9.5 ←																								
15: *10.7 ↘																								
16: 8.6 ←																								
17: 9.0 ↓																								
18: *10.5 ↘																								
19: 9.8 ↘																								
20: 8.5 ↘																								
Serie	88.0																							
Total	162.0																							
<table style="width:100%; border-collapse: collapse; margin-top: 5px;"> <tr><td style="text-align: right;">Serie</td><td style="text-align: right;">88.0</td></tr> <tr><td style="text-align: right;">Total</td><td style="text-align: right;">162.0</td></tr> </table>	Serie	88.0	Total	162.0	<table style="width:100%; border-collapse: collapse; margin-top: 5px;"> <tr><td style="text-align: right;">Serie</td><td style="text-align: right;">88.0</td></tr> <tr><td style="text-align: right;">Total</td><td style="text-align: right;">162.0</td></tr> </table>	Serie	88.0	Total	162.0	<table style="width:100%; border-collapse: collapse;"> <tr><td>21: 8.9 ←</td></tr> <tr><td>22: 5.9 ←</td></tr> <tr><td>23: 9.5 ←</td></tr> <tr><td>24: 8.2 ↘</td></tr> <tr><td>25: 9.4 ↗</td></tr> <tr><td>26: 7.9 ←</td></tr> <tr><td>27: *10.6 ↓</td></tr> <tr><td>28: 9.7 ←</td></tr> <tr><td>29: *10.2 ↘</td></tr> <tr><td>30: *10.3 ↓</td></tr> </table> <table style="width:100%; border-collapse: collapse; margin-top: 5px;"> <tr><td style="text-align: right;">Serie</td><td style="text-align: right;">85.0</td></tr> <tr><td style="text-align: right;">Total</td><td style="text-align: right;">247.0</td></tr> </table>	21: 8.9 ←	22: 5.9 ←	23: 9.5 ←	24: 8.2 ↘	25: 9.4 ↗	26: 7.9 ←	27: *10.6 ↓	28: 9.7 ←	29: *10.2 ↘	30: *10.3 ↓	Serie	85.0	Total	247.0
Serie	88.0																							
Total	162.0																							
Serie	88.0																							
Total	162.0																							
21: 8.9 ←																								
22: 5.9 ←																								
23: 9.5 ←																								
24: 8.2 ↘																								
25: 9.4 ↗																								
26: 7.9 ←																								
27: *10.6 ↓																								
28: 9.7 ←																								
29: *10.2 ↘																								
30: *10.3 ↓																								
Serie	85.0																							
Total	247.0																							
<table style="width:100%; border-collapse: collapse; margin-top: 5px;"> <tr><td style="text-align: right;">Serie</td><td style="text-align: right;">88.0</td></tr> <tr><td style="text-align: right;">Total</td><td style="text-align: right;">162.0</td></tr> </table>	Serie	88.0	Total	162.0	<table style="width:100%; border-collapse: collapse; margin-top: 5px;"> <tr><td style="text-align: right;">Serie</td><td style="text-align: right;">85.0</td></tr> <tr><td style="text-align: right;">Total</td><td style="text-align: right;">247.0</td></tr> </table>	Serie	85.0	Total	247.0	<table style="width:100%; border-collapse: collapse; margin-top: 5px;"> <tr><td style="text-align: right;">Serie</td><td style="text-align: right;">85.0</td></tr> <tr><td style="text-align: right;">Total</td><td style="text-align: right;">247.0</td></tr> </table>	Serie	85.0	Total	247.0										
Serie	88.0																							
Total	162.0																							
Serie	85.0																							
Total	247.0																							
Serie	85.0																							
Total	247.0																							

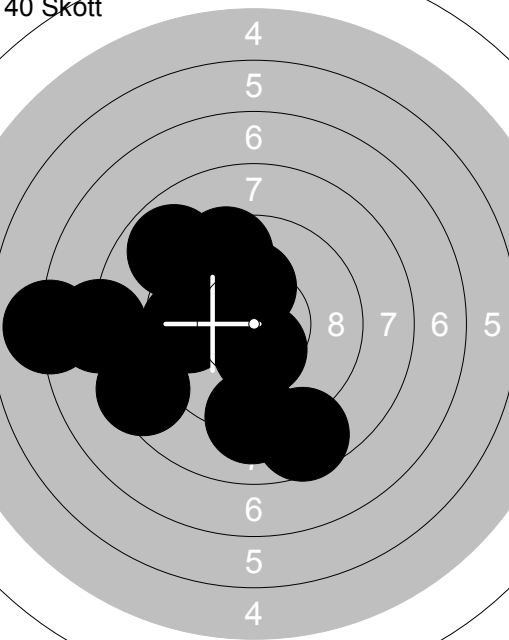
<p>40 Skott</p> 	<table style="width:100%; border-collapse: collapse;"> <tr><td>31: 9.7 ←</td></tr> <tr><td>32: 7.0 ←</td></tr> <tr><td>33: 8.9 ↗</td></tr> <tr><td>34: 8.6 ↘</td></tr> <tr><td>35: *10.4 ↓</td></tr> <tr><td>36: 9.2 ↓</td></tr> <tr><td>37: *10.2 ↗</td></tr> <tr><td>38: 9.5 ↗</td></tr> <tr><td>39: 8.5 ←</td></tr> <tr><td>40: 8.0 ←</td></tr> </table> <table style="width:100%; border-collapse: collapse; margin-top: 5px;"> <tr><td style="text-align: right;">Serie</td><td style="text-align: right;">86.0</td></tr> <tr><td style="text-align: right;">Total</td><td style="text-align: right;">333.0</td></tr> </table>	31: 9.7 ←	32: 7.0 ←	33: 8.9 ↗	34: 8.6 ↘	35: *10.4 ↓	36: 9.2 ↓	37: *10.2 ↗	38: 9.5 ↗	39: 8.5 ←	40: 8.0 ←	Serie	86.0	Total	333.0	<table style="width:100%; border-collapse: collapse; margin-top: 5px;"> <tr><td style="text-align: right;">Serie</td><td style="text-align: right;">86.0</td></tr> <tr><td style="text-align: right;">Total</td><td style="text-align: right;">333.0</td></tr> </table>	Serie	86.0	Total	333.0
31: 9.7 ←																				
32: 7.0 ←																				
33: 8.9 ↗																				
34: 8.6 ↘																				
35: *10.4 ↓																				
36: 9.2 ↓																				
37: *10.2 ↗																				
38: 9.5 ↗																				
39: 8.5 ←																				
40: 8.0 ←																				
Serie	86.0																			
Total	333.0																			
Serie	86.0																			
Total	333.0																			
<table style="width:100%; border-collapse: collapse; margin-top: 5px;"> <tr><td style="text-align: right;">Serie</td><td style="text-align: right;">86.0</td></tr> <tr><td style="text-align: right;">Total</td><td style="text-align: right;">333.0</td></tr> </table>	Serie	86.0	Total	333.0	<table style="width:100%; border-collapse: collapse; margin-top: 5px;"> <tr><td style="text-align: right;">Serie</td><td style="text-align: right;">86.0</td></tr> <tr><td style="text-align: right;">Total</td><td style="text-align: right;">333.0</td></tr> </table>	Serie	86.0	Total	333.0	<table style="width:100%; border-collapse: collapse; margin-top: 5px;"> <tr><td style="text-align: right;">Serie</td><td style="text-align: right;">86.0</td></tr> <tr><td style="text-align: right;">Total</td><td style="text-align: right;">333.0</td></tr> </table>	Serie	86.0	Total	333.0						
Serie	86.0																			
Total	333.0																			
Serie	86.0																			
Total	333.0																			
Serie	86.0																			
Total	333.0																			

<p>Prov</p>	<p>1: *10.6 →</p> <p>2: *10.3 ↗</p> <p>3: 10.0 ↖</p> <p>4: *10.6 ↘</p> <p>5: 10.0 ↙</p> <p>6: 10.1 ↖</p> <p>7: 10.0 ↘</p> <p>8: *10.5 ↗</p> <p>9: *10.3 ↗</p> <p>10: 10.0 ↖</p> <hr/> <p>Serie 100.0</p> <p>Total 0.0</p>	<p>Prov</p>	<p>11: 10.0 ↑</p> <p>12: 9.8 ↗</p> <p>13: 10.1 ↗</p> <p>14: *10.5 ↘</p> <p>15: *10.3 →</p> <hr/> <p>Serie 49.0</p> <p>Total 0.0</p>
<p>40 Skott</p>	<p>1: 9.5 ↑</p> <p>2: *10.8 ↗</p> <p>3: *10.6 ↘</p> <p>4: *10.4 ↗</p> <p>5: *10.3 ↗</p> <p>6: *10.5 ↗</p> <p>7: *10.3 ↘</p> <p>8: *10.5 ↘</p> <p>9: *10.2 ↑</p> <p>10: *10.7 ↗</p> <hr/> <p>Serie 99.0</p> <p>Total 99.0</p>	<p>40 Skott</p>	<p>11: *10.2 ↗</p> <p>12: *10.5 ↗</p> <p>13: 9.9 ↑</p> <p>14: 9.9 ↗</p> <p>15: *10.3 ↘</p> <p>16: *10.4 →</p> <p>17: *10.5 ↘</p> <p>18: 10.1 ↖</p> <p>19: *10.7 ↖</p> <p>20: 9.9 ↗</p> <hr/> <p>Serie 97.0</p> <p>Total 196.0</p>
<p>40 Skott</p>	<p>21: *10.3 →</p> <p>22: 10.1 ↘</p> <p>23: *10.7 →</p> <p>24: 10.1 ↑</p> <p>25: *10.5 ↘</p> <p>26: *10.4 ↘</p> <p>27: 9.8 ↑</p> <p>28: 9.9 ←</p> <p>29: 10.1 ↑</p> <p>30: 9.7 ↖</p> <hr/> <p>Serie 97.0</p> <p>Total 293.0</p>	<p>40 Skott</p>	<p>31: *10.4 ↘</p> <p>32: *10.6 ↘</p> <p>33: *10.3 ↗</p> <p>34: *10.6 →</p> <p>35: *10.7 ↖</p> <p>36: *10.4 ↖</p> <p>37: *10.7 ↘</p> <p>38: *10.6 ↘</p> <p>39: *10.2 ↖</p> <p>40: *10.7 ↖</p> <hr/> <p>Serie 100.0</p> <p>Total 393.0</p>

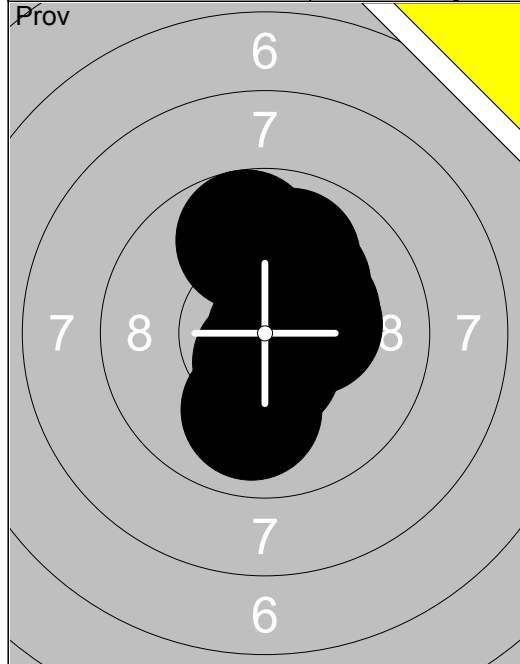

1:	10.0 ↓
2:	*10.3 →
3:	*10.4 →
4:	*10.2 ↗
5:	*10.8 →
6:	*10.5 ↓
7:	*10.3 →
8:	9.9 ↑
9:	9.7 ↑
10:	*10.6 ↓
<b>Serie 98.0</b>	
<b>Total 0.0</b>	

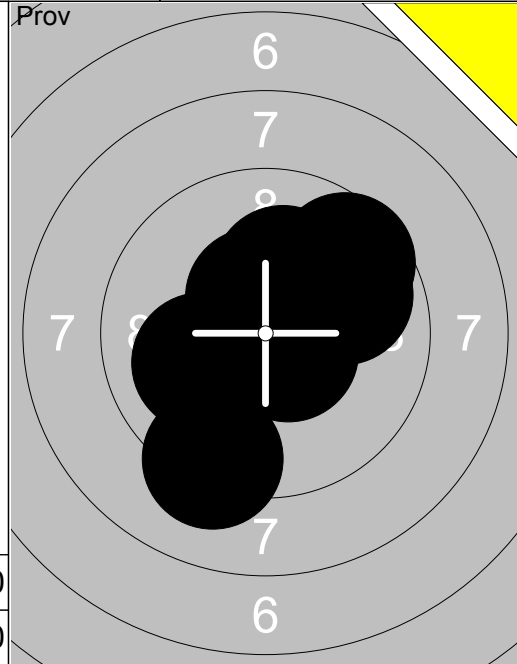

11:	*10.6 →
12:	*10.7 ↗
13:	9.2 ↓
14:	*10.6 ↘
15:	9.8 →
16:	*10.3 →
17:	*10.2 ↗
18:	9.6 ↗
19:	*10.5 ↗
20:	10.1 ↙
<b>Serie 97.0</b>	
<b>Total 0.0</b>	

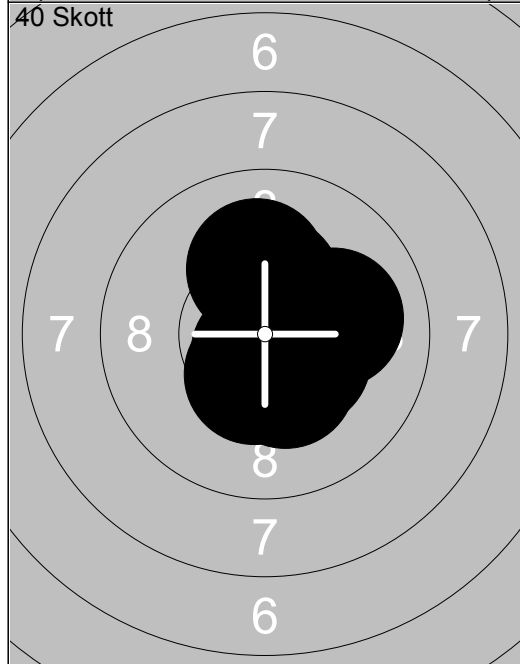

1:	10.1 ↑
2:	*10.6 ↓
3:	*10.3 ↑
4:	*10.4 ↘
5:	10.1 →
6:	*10.7 ↓
7:	*10.4 →
8:	*10.4 ↓
9:	*10.3 ↘
10:	*10.5 ↓
<b>Serie 100.0</b>	
<b>Total 100.0</b>	

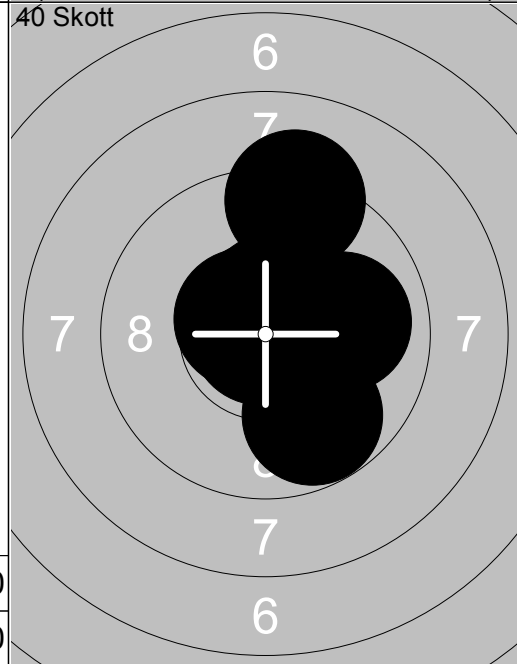

11:	9.2 ↑
12:	*10.9 ↙
13:	*10.4 →
14:	*10.7 ↗
15:	*10.7 ↗
16:	9.8 ↓
17:	10.0 →
18:	*10.4 →
19:	*10.6 ↙
20:	*10.5 ↗
<b>Serie 98.0</b>	
<b>Total 198.0</b>	

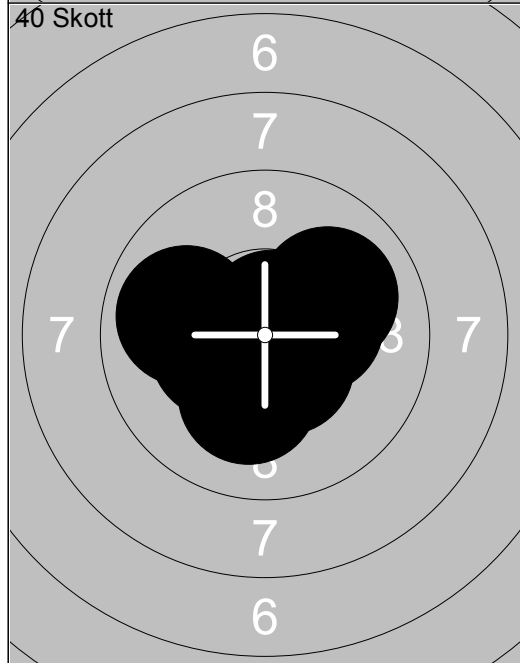

21:	*10.5 ↘
22:	*10.2 ↓
23:	*10.7 ↗
24:	*10.5 →
25:	10.0 ↗
26:	*10.4 ↙
27:	*10.3 →
28:	9.9 ↙
29:	*10.4 ↙
30:	*10.5 ↓
<b>Serie 99.0</b>	
<b>Total 297.0</b>	

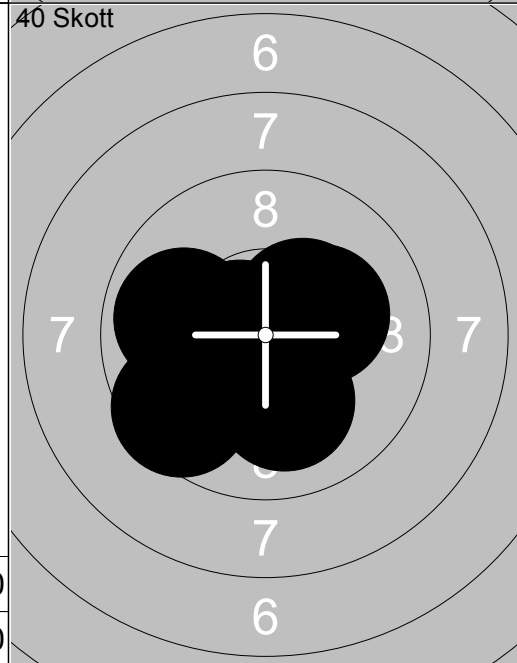

31:	9.5 ↙
32:	10.1 ↓
33:	*10.2 →
34:	*10.4 →
35:	9.9 ↙
36:	*10.5 ↙
37:	*10.4 ↓
38:	*10.6 ↙
39:	*10.7 ↓
40:	*10.9 ↗
<b>Serie 98.0</b>	
<b>Total 395.0</b>	



<p>Prov</p>	<p>1: 9.3 → 2: 9.7 ↘ 3: 9.4 ↘ 4: 9.7 → 5: *10.3 ↓ 6: *10.8 ↘ 7: 10.0 ← 8: 9.7 ← 9: 10.0 ↘ 10: *10.7 ↗</p> <p>Serie 95.0 Total 0.0</p>	<p>Prov</p>	<p>11: 9.8 ↘ 12: *10.3 → 13: *10.5 →</p> <p>Serie 29.0 Total 0.0</p>
-------------	---	-------------	--

<p>40 Skott</p>	<p>1: *10.9 ↗ 2: 9.8 ← 3: *10.6 ↓ 4: *10.8 ↘ 5: *10.9 ↘ 6: 10.1 → 7: 10.0 ↗ 8: 9.5 → 9: 9.6 ↗ 10: *10.3 ↑</p> <p>Serie 97.0 Total 97.0</p>	<p>40 Skott</p>	<p>11: *10.5 ↘ 12: *10.2 → 13: *10.7 → 14: *10.8 ↘ 15: *10.2 ↗ 16: *10.5 ↗ 17: 9.7 ↘ 18: 9.4 ↗ 19: 9.4 ↓ 20: *10.3 ↓</p> <p>Serie 97.0 Total 194.0</p>
-----------------	--	-----------------	--

<p>40 Skott</p>	<p>21: 9.1 → 22: 9.9 ↘ 23: *10.6 → 24: 9.6 → 25: 10.1 ↓ 26: 9.9 ↓ 27: 9.8 ↗ 28: *10.6 ↓ 29: *10.4 ↑ 30: *10.3 →</p> <p>Serie 95.0 Total 289.0</p>	<p>40 Skott</p>	<p>31: 9.8 → 32: 9.3 ↗ 33: 9.8 ↑ 34: 9.8 → 35: 9.8 ↗ 36: *10.9 → 37: *10.6 ↗ 38: *10.7 → 39: 10.1 ↘ 40: 9.7 ↑</p> <p>Serie 94.0 Total 383.0</p>
-----------------	---	-----------------	---

<p>Prov</p>	<p>1: *10.6↓</p> <p>2: *10.3→</p> <p>3: 10.1 ↓</p> <p>4: *10.7↑</p> <p>5: *10.8←</p> <p>6: 10.0→</p> <p>7: *10.7↓</p> <p>8: 10.0→</p> <p>9: *10.4↓</p> <p>10: 10.1 ↗</p>	<p>40 Skott</p>	<p>1: 10.0↙</p> <p>2: 10.0→</p> <p>3: *10.8↑</p> <p>4: *10.4↖</p> <p>5: *10.7↖</p> <p>6: *10.3←</p> <p>7: *10.7↓</p> <p>8: 10.0 ↗</p> <p>9: *10.7↖</p> <p>10: *10.6↗</p>
Serie	100.0	Serie	100.0
Total	0.0	Total	100.0

<p>40 Skott</p>	<p>11: 9.9 ↖</p> <p>12: *10.5↑</p> <p>13: *10.2↙</p> <p>14: 10.1 ↓</p> <p>15: *10.6←</p> <p>16: *10.3↖</p> <p>17: *10.4↑</p> <p>18: *10.3↑</p> <p>19: *10.4↑</p> <p>20: *10.7↗</p>	<p>40 Skott</p>	<p>21: *10.2→</p> <p>22: *10.4↖</p> <p>23: *10.5↓</p> <p>24: *10.6→</p> <p>25: *10.3↑</p> <p>26: *10.8↑</p> <p>27: *10.9↗</p> <p>28: *10.5↑</p> <p>29: 9.6 →</p> <p>30: *10.4↘</p>
Serie	99.0	Serie	99.0
Total	199.0	Total	298.0

<p>40 Skott</p>	<p>31: *10.2↓</p> <p>32: *10.3↖</p> <p>33: *10.3↗</p> <p>34: *10.7↖</p> <p>35: *10.4↘</p> <p>36: *10.2→</p> <p>37: *10.2↘</p> <p>38: *10.5→</p> <p>39: *10.9↖</p> <p>40: *10.5↖</p>		
Serie	100.0		
Total	398.0		

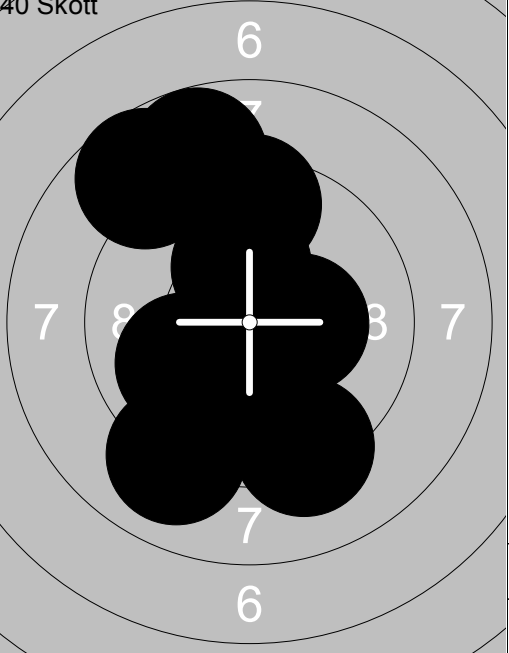
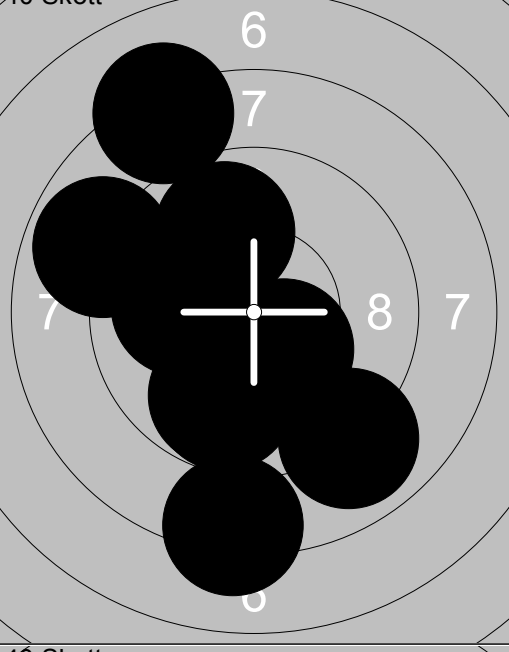
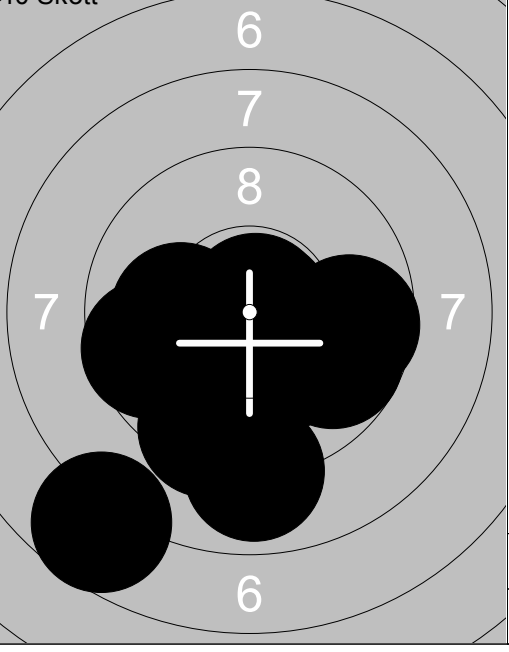
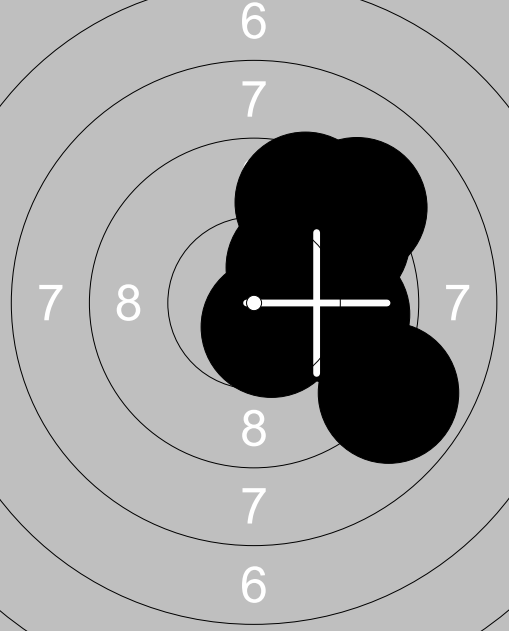

Prov 	1: 9.7 ↗ 2: 9.9 ↑ 3: *10.5 → 4: *10.4 ↑ 5: *10.4 → 6: *10.2 ↘ 7: 10.1 ← 8: 9.5 ↗ 9: 9.0 ↑ 10: 10.1 → <hr/> Serie 96.0 Total 0.0	40 Skott 	1: *10.3 ↓ 2: 10.0 ↙ 3: 9.0 ↓ 4: 8.7 ↑ 5: 8.7 ↗ 6: 9.4 ↑ 7: *10.7 ↑ 8: *10.2 ↑ 9: 9.2 ↓ 10: *10.3 → <hr/> Serie 93.0 Total 93.0
40 Skott 	11: 9.8 ↓ 12: 8.2 ↓ 13: 8.9 ↓ 14: 8.9 ↙ 15: 9.9 ↑ 16: 8.2 ↑ 17: *10.3 ↓ 18: 9.8 ↓ 19: *10.2 ↓ 20: 10.0 ← <hr/> Serie 89.0 Total 182.0	40 Skott 	21: 7.7 ↓ 22: 9.6 ← 23: 10.1 ← 24: 9.7 → 25: 9.7 → 26: 8.9 ↓ 27: 9.4 ↓ 28: *10.2 ↓ 29: *10.8 ↗ 30: *10.8 → <hr/> Serie 91.0 Total 273.0
40 Skott 	31: 9.2 ↗ 32: *10.2 ↗ 33: *10.6 ↓ 34: 9.8 → 35: 9.5 ↑ 36: 8.9 ↘ 37: *10.4 → 38: 10.0 ↗ 39: 9.6 ↗ 40: 10.0 → <hr/> Serie 94.0 Total 367.0		

Prov 	1: 9.9 ← 2: 9.9 ↓ 3: *10.3 ↘ 4: *10.5 ↘ 5: *10.4 ↓ 6: *10.5 ↗ 7: 10.0 ↑ 8: *10.7 ↑ 9: *10.6 ↑ 10: *10.5 ↓ Serie 98.0 Total 0.0	Prov 	11: *10.6 ↘ 12: *10.6 ↘ 13: 10.1 ↖ 14: 10.1 ↖ Serie 40.0 Total 0.0
----------	---	----------	---

40 Skott 	1: *10.2 ↘ 2: 9.0 ← 3: *10.4 ↘ 4: *10.4 ↘ 5: *10.5 ↓ 6: 9.4 ↖ 7: 9.9 ↘ 8: *10.6 ↖ 9: *10.5 ↑ 10: 9.6 ↖ Serie 96.0 Total 96.0	40 Skott 	11: *10.2 ↑ 12: *10.2 ↘ 13: *10.3 ↖ 14: 10.0 ↑ 15: *10.2 ↘ 16: *10.4 ↖ 17: 10.1 ↖ 18: *10.2 ↗ 19: *10.2 ↖ 20: 10.1 ← Serie 100.0 Total 196.0
--------------	---	--------------	---

40 Skott 	21: *10.3 ↖ 22: *10.3 ↘ 23: *10.3 ↘ 24: *10.8 ↖ 25: 9.7 ↖ 26: 9.7 ↑ 27: 10.0 ↖ 28: *10.4 ↖ 29: *10.6 ↑ 30: *10.4 ↖ Serie 98.0 Total 294.0	40 Skott 	31: 9.8 ← 32: 9.7 ↖ 33: *10.5 ↓ 34: *10.6 ↘ 35: 9.6 ↓ 36: 9.9 ↖ 37: *10.3 ↗ 38: 10.1 ← 39: 10.1 ← 40: 9.8 ↖ Serie 95.0 Total 389.0
--------------	--	--------------	---

Skjutlag	Tavla	Linus Persson			
1	23	10m	Umeå	13	Vb
02.11.2014	Vindelnskyttet 2014	Ramselefors SKF			
Prov		1: 10.0 ↓ 2: 10.0 ↓ 3: *10.3 ↘ 4: *10.9 ↘ 5: *10.2 ↓ 6: *10.2 → 7: *10.4 → 8: *10.2 ↗ 9: 10.1 ↓ 10: *10.2 →	Prov	11: 10.1 ↘ 12: *10.3 ↘ 13: *10.4 ↘ 14: *10.3 ↘ 15: *10.4 ↗	
		Serie 100.0		Serie 50.0	
		Total 0.0		Total 0.0	
40 Skott		1: *10.5 ↘ 2: *10.2 ↑ 3: 9.6 ↑ 4: 10.0 ↑ 5: *10.6 ↘ 6: 9.6 ↘ 7: *10.5 ↘ 8: 10.0 ↘ 9: *10.3 ↗ 10: *10.4 ↘	40 Skott	11: *10.3 ↘ 12: *10.9 ↓ 13: *10.2 ↘ 14: *10.6 ↘ 15: *10.8 ↘ 16: *10.3 ↘ 17: *10.9 ↘ 18: *10.7 ↓ 19: *10.3 → 20: *10.7 ↓	
		Serie 98.0		Serie 100.0	
		Total 98.0		Total 198.0	
40 Skott		21: 9.7 ↘ 22: 10.0 ↑ 23: 10.0 ↘ 24: *10.6 ↑ 25: 10.1 ↑ 26: 9.7 ← 27: *10.2 ↑ 28: *10.5 ↘ 29: *10.2 ↘ 30: *10.3 ↘	40 Skott	31: 10.1 ↘ 32: 9.8 ↑ 33: *10.2 ↘ 34: 10.1 ↑ 35: 10.1 ↘ 36: *10.5 → 37: 9.6 ↑ 38: *10.2 ↘ 39: *10.2 ↓ 40: 10.1 ↘	
		Serie 98.0		Serie 98.0	
		Total 296.0		Total 394.0	

<p>Prov</p>	<p>1: 9.4 ↖                  2: *10.8↑                  3: *10.5↗                  4: *10.2↑                  5: *10.7↑                  6: *10.4↓                  7: *10.3→                  8: 9.7 ↓                  9: *10.8↗                  10: *10.8→</p>	<p>Prov</p>	<p>11: *10.4→                  12: *10.7↑                  13: *10.3↘                  14: 10.0↙                  15: 10.0↙                  16: *10.3↘                  17: *10.7↘</p>
Serie	98.0	Serie	70.0
Total	0.0	Total	0.0

<p>40 Skott</p>	<p>1: *10.5↘                  2: *10.4↗                  3: *10.6↗                  4: *10.9→                  5: *10.3↘                  6: *10.4↙                  7: *10.5↙                  8: 10.1↙                  9: *10.7→                  10: *10.7→</p>	<p>40 Skott</p>	<p>11: *10.3↑                  12: 9.8 ↓                  13: *10.3→                  14: *10.7↗                  15: *10.2↙                  16: *10.3↘                  17: *10.6↘                  18: 10.0 ↓                  19: *10.2↙                  20: *10.2→</p>
Serie	100.0	Serie	99.0
Total	100.0	Total	199.0

<p>40 Skott</p>	<p>21: *10.2↘                  22: *10.6↙                  23: *10.5↗                  24: 9.9 →                  25: *10.9↓                  26: *10.8↗                  27: *10.5↙                  28: *10.7↑                  29: 9.8 ↙                  30: *10.8↙</p>	<p>40 Skott</p>	<p>31: 9.9 ↑                  32: *10.6↙                  33: *10.9↗                  34: *10.3↙                  35: *10.2→                  36: *10.6↗                  37: *10.7↗                  38: *10.3↑                  39: *10.4→                  40: *10.5↓</p>
Serie	98.0	Serie	99.0
Total	297.0	Total	396.0

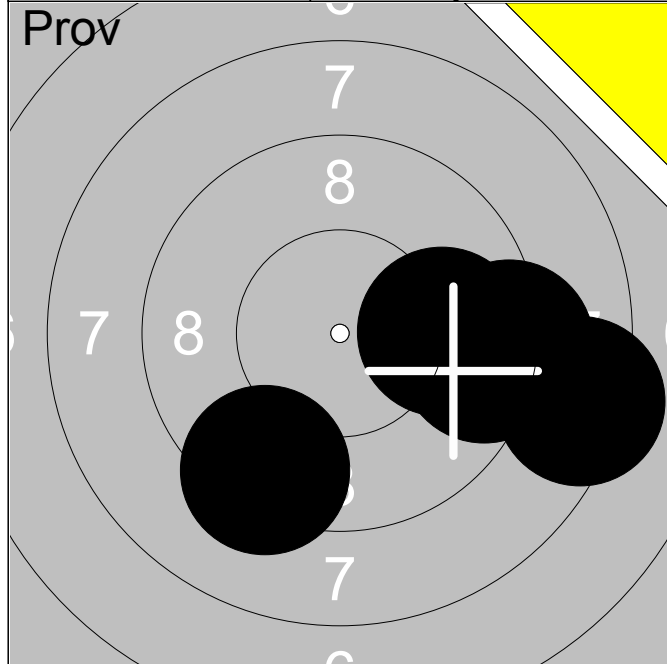

	1:	9.9	→
	2:	9.3	↓
	3:	8.3	→
	4:	9.4	→
	5:	9.2	→
<b>Serie</b>			<b>44.0</b>
<b>Total</b>			<b>0.0</b>

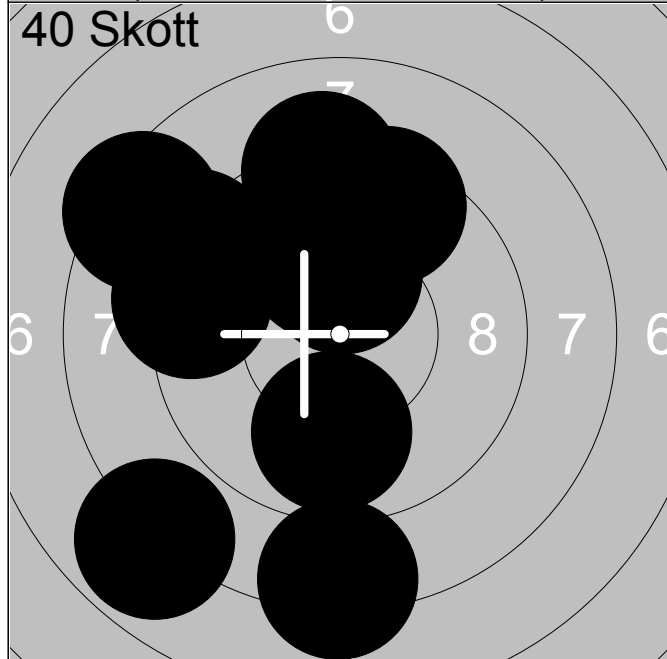

	1:	8.2	↓
	2:	7.9	↙
	3:	8.3	↗
	4:	9.9	↓
	5:	*10.3	↑
	6:	9.4	↑
	7:	10.1	↑
	8:	9.1	↗
	9:	9.2	←
	10:	9.1	↑
<b>Serie</b>			<b>88.0</b>
<b>Total</b>			<b>88.0</b>

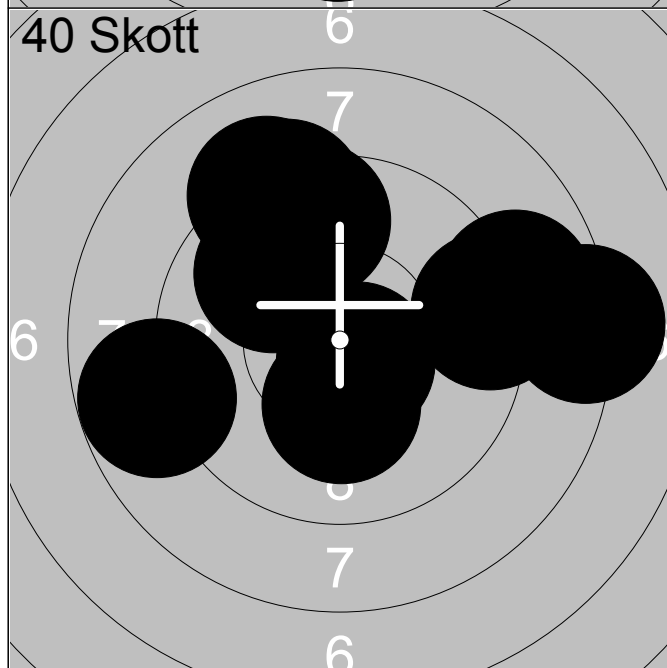

	11:	8.1	→
	12:	8.9	→
	13:	9.9	↗
	14:	9.2	↑
	15:	9.1	↗
	16:	9.5	↑
	17:	8.8	←
	18:	*10.2	↓
	19:	*10.6	↓
	20:	9.2	→
<b>Serie</b>			<b>89.0</b>
<b>Total</b>			<b>177.0</b>

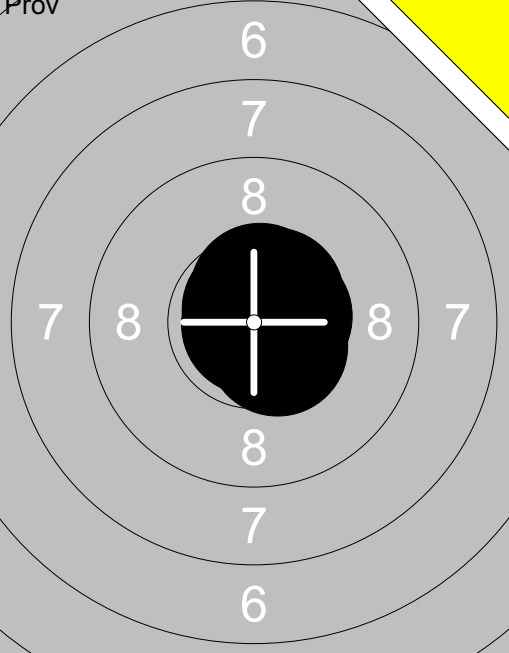
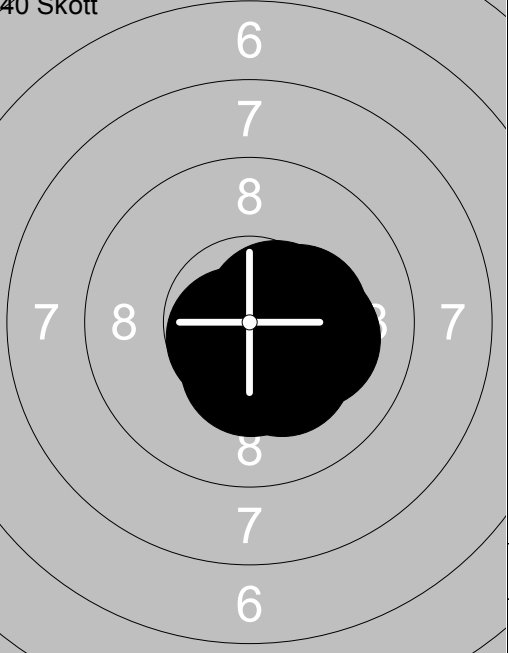
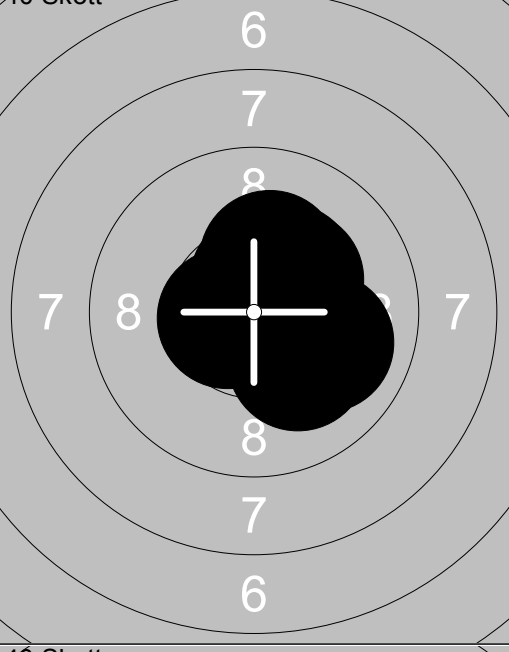
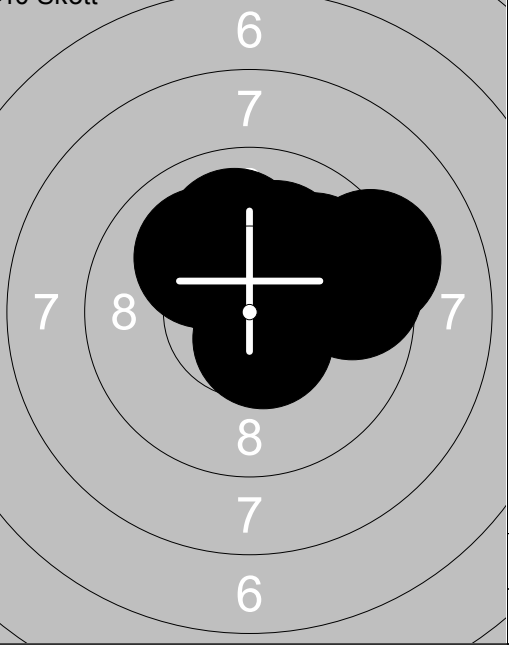
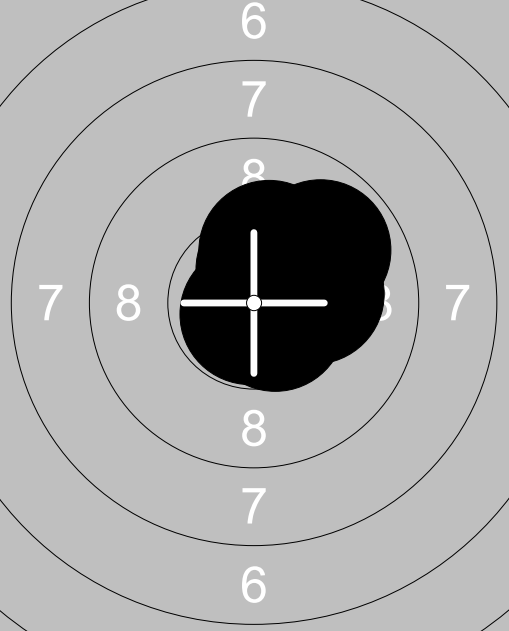
<p>Prov</p>  <p style="text-align: center;">6 7 8 7 8 8 7 8 7 6</p>	<p>1: *10.5 ↘ 2: *10.6 → 3: *10.6 ↑ 4: *10.6 ↗ 5: *10.8 ↑ 6: *10.9 ↙</p> <p>Serie 60.0 Total 0.0</p>	<p>40 Skott</p>  <p style="text-align: center;">6 7 8 7 8 8 7 8 7 6</p> <p>1: *10.6 ↗ 2: *10.8 ↘ 3: *10.3 ↘ 4: 10.1 → 5: *10.3 → 6: *10.4 ↓ 7: *10.6 → 8: *10.2 → 9: *10.7 ↙ 10: *10.4 ↓</p> <p>Serie 100.0 Total 100.0</p>
<p>40 Skott</p>  <p style="text-align: center;">6 7 8 7 8 8 7 8 7 6</p>	<p>11: *10.7 ↗ 12: *10.6 → 13: *10.3 ↘ 14: 10.1 ↘ 15: 10.0 → 16: *10.6 ← 17: *10.3 ↗ 18: *10.3 ↗ 19: *10.3 ↑ 20: *10.5 ↑</p> <p>Serie 100.0 Total 200.0</p>	<p>40 Skott</p>  <p style="text-align: center;">6 7 8 7 8 8 7 8 7 6</p> <p>21: 9.9 ↗ 22: 10.0 ↖ 23: *10.5 ↑ 24: 9.6 → 25: 10.0 ↑ 26: *10.2 ↖ 27: 10.1 ↑ 28: 9.3 ↗ 29: *10.8 ↗ 30: *10.6 ↓</p> <p>Serie 97.0 Total 297.0</p>
<p>40 Skott</p>  <p style="text-align: center;">6 7 8 7 8 8 7 8 7 6</p>	<p>31: *10.2 → 32: *10.8 ↓ 33: *10.6 → 34: *10.4 → 35: *10.9 → 36: *10.7 ↘ 37: *10.3 ↑ 38: 9.9 ↗ 39: *10.6 ↘ 40: *10.5 ↑</p> <p>Serie 99.0 Total 396.0</p>	



<p>Prov</p>	<p>1: 9.5 ↓ 2: 9.4 ↓ 3: 9.7 ↑ 4: 9.9 → 5: 9.9 ↗ 6: 9.5 ↑ 7: *10.6 ↗ 8: 9.8 ↓ 9: 10.1 ↓ 10: *10.6 ↓</p> <p>Serie 93.0 Total 0.0</p>	<p>Prov</p>	<p>11: *10.4 ↗</p> <p>Serie 10.0 Total 0.0</p>
-------------	--	-------------	--

<p>40 Skott</p>	<p>1: *10.2 ↗ 2: *10.5 ↑ 3: *10.2 ↘ 4: 10.0 → 5: *10.3 ↓ 6: *10.7 ↘ 7: *10.6 ← 8: *10.4 ↓ 9: 9.8 ↓ 10: *10.3 ↘</p> <p>Serie 99.0 Total 99.0</p>	<p>40 Skott</p>	<p>11: *10.6 ← 12: *10.5 ↗ 13: *10.8 ← 14: *10.5 ← 15: *10.3 ↘ 16: *10.8 ↘ 17: *10.2 → 18: *10.3 ↗ 19: *10.6 ← 20: 10.1 ↗</p> <p>Serie 100.0 Total 199.0</p>
-----------------	---	-----------------	--

<p>40 Skott</p>	<p>21: *10.3 ↗ 22: *10.4 ↑ 23: 10.1 ↓ 24: *10.5 ↘ 25: 10.0 → 26: *10.2 ↘ 27: 9.8 ↓ 28: *10.7 → 29: 9.6 ↓ 30: 9.0 ↘</p> <p>Serie 97.0 Total 296.0</p>	<p>40 Skott</p>	<p>31: 10.1 ↗ 32: *10.3 → 33: *10.3 ↗ 34: *10.7 ↗ 35: *10.5 ↑ 36: *10.3 ↗ 37: *10.4 ← 38: *10.7 ↘ 39: *10.5 ↘ 40: *10.4 ↘</p> <p>Serie 100.0 Total 396.0</p>
-----------------	--	-----------------	--

<p>Prov</p>	<p>1: 9.1 →</p> <p>2: 9.4 ↖</p> <p>3: 9.4 ↗</p> <p>4: *10.3↑</p> <p>5: *10.2↘</p> <p>6: *10.6↓</p> <p>7: 9.9 →</p> <p>8: 9.4 ↖</p> <p>9: 10.0←</p> <p>10: 9.9 →</p>	<p>Prov</p>	<p>11: *10.5↖</p>
Serie	94.0	Serie	10.0
Total	0.0	Total	0.0

<p>40 Skott</p>	<p>1: *10.5↓</p> <p>2: 10.1→</p> <p>3: 9.3 ↓</p> <p>4: 10.0↖</p> <p>5: *10.4↖</p> <p>6: 9.9 ↓</p> <p>7: *10.5↖</p> <p>8: 8.5 →</p> <p>9: *10.4→</p> <p>10: 10.0 ↑</p>	<p>40 Skott</p>	<p>11: *10.6←</p> <p>12: *10.3↘</p> <p>13: *10.2↗</p> <p>14: 9.1 ↑</p> <p>15: *10.5↓</p> <p>16: *10.2↖</p> <p>17: *10.2↘</p> <p>18: 9.7 ↓</p> <p>19: 10.1 ↗</p> <p>20: *10.8→</p>
Serie	96.0	Serie	98.0
Total	96.0	Total	194.0

<p>40 Skott</p>	<p>21: 8.1 ↖</p> <p>22: 8.5 ↓</p> <p>23: 10.0 ↓</p> <p>24: 9.8 ↖</p> <p>25: *10.3↖</p> <p>26: 7.8 ↗</p> <p>27: *10.7↖</p> <p>28: 10.0 ↓</p> <p>29: *10.2↓</p> <p>30: 8.8 ↖</p>	<p>40 Skott</p>	<p>31: 10.0←</p> <p>32: 10.1↖</p> <p>33: 10.0 ↑</p> <p>34: 9.7 ↖</p> <p>35: 10.1 ↑</p> <p>36: 9.3 →</p> <p>37: *10.4↑</p> <p>38: 10.0 ↗</p> <p>39: 8.8 ↘</p> <p>40: 9.4 →</p>
Serie	90.0	Serie	95.0
Total	284.0	Total	379.0

<p>Prov</p>	<p>40 Skott</p>	<table style="width:100%; border-collapse: collapse;"> <tr><td>1: *10.5</td><td>↘</td><td>1: 10.1</td><td>←</td></tr> <tr><td>2: 9.7</td><td>↓</td><td>2: 8.0</td><td>↑</td></tr> <tr><td>3: 10.1</td><td>←</td><td>3: 9.2</td><td>←</td></tr> <tr><td>4: 9.7</td><td>↙</td><td>4: 9.9</td><td>↗</td></tr> <tr><td>5: *10.2</td><td>↘</td><td>5: 9.9</td><td>↑</td></tr> <tr><td>6: 9.8</td><td>↓</td><td>6: 9.4</td><td>↘</td></tr> <tr><td>7: *10.7</td><td>↘</td><td>7: 9.3</td><td>↑</td></tr> <tr><td>8: *10.6</td><td>↘</td><td>8: 8.3</td><td>←</td></tr> <tr><td>9: 9.8</td><td>↗</td><td>9: *10.2</td><td>↘</td></tr> <tr><td>10: *10.6</td><td>↘</td><td>10: 9.5</td><td>↘</td></tr> <tr><td colspan="2"><b>Serie 96.0</b></td><td colspan="2"><b>Serie 90.0</b></td></tr> <tr><td colspan="2"><b>Total 0.0</b></td><td colspan="2"><b>Total 90.0</b></td></tr> </table>	1: *10.5	↘	1: 10.1	←	2: 9.7	↓	2: 8.0	↑	3: 10.1	←	3: 9.2	←	4: 9.7	↙	4: 9.9	↗	5: *10.2	↘	5: 9.9	↑	6: 9.8	↓	6: 9.4	↘	7: *10.7	↘	7: 9.3	↑	8: *10.6	↘	8: 8.3	←	9: 9.8	↗	9: *10.2	↘	10: *10.6	↘	10: 9.5	↘	<b>Serie 96.0</b>		<b>Serie 90.0</b>		<b>Total 0.0</b>		<b>Total 90.0</b>	
1: *10.5	↘	1: 10.1	←																																															
2: 9.7	↓	2: 8.0	↑																																															
3: 10.1	←	3: 9.2	←																																															
4: 9.7	↙	4: 9.9	↗																																															
5: *10.2	↘	5: 9.9	↑																																															
6: 9.8	↓	6: 9.4	↘																																															
7: *10.7	↘	7: 9.3	↑																																															
8: *10.6	↘	8: 8.3	←																																															
9: 9.8	↗	9: *10.2	↘																																															
10: *10.6	↘	10: 9.5	↘																																															
<b>Serie 96.0</b>		<b>Serie 90.0</b>																																																
<b>Total 0.0</b>		<b>Total 90.0</b>																																																

<p>40 Skott</p>	<p>40 Skott</p>	<table style="width:100%; border-collapse: collapse;"> <tr><td>11: 9.8</td><td>↗</td><td>21: *10.6</td><td>↘</td></tr> <tr><td>12: 9.8</td><td>→</td><td>22: 10.1</td><td>↗</td></tr> <tr><td>13: 9.8</td><td>→</td><td>23: 10.1</td><td>↘</td></tr> <tr><td>14: 10.1</td><td>↑</td><td>24: 10.1</td><td>↑</td></tr> <tr><td>15: 9.8</td><td>←</td><td>25: 9.2</td><td>←</td></tr> <tr><td>16: 9.3</td><td>↑</td><td>26: 10.1</td><td>↗</td></tr> <tr><td>17: 10.1</td><td>↘</td><td>27: 9.7</td><td>←</td></tr> <tr><td>18: 9.7</td><td>↑</td><td>28: 10.0</td><td>↘</td></tr> <tr><td>19: 9.8</td><td>←</td><td>29: 9.2</td><td>←</td></tr> <tr><td>20: 9.4</td><td>←</td><td>30: 8.2</td><td>↘</td></tr> <tr><td colspan="2"><b>Serie 92.0</b></td><td colspan="2"><b>Serie 95.0</b></td></tr> <tr><td colspan="2"><b>Total 182.0</b></td><td colspan="2"><b>Total 277.0</b></td></tr> </table>	11: 9.8	↗	21: *10.6	↘	12: 9.8	→	22: 10.1	↗	13: 9.8	→	23: 10.1	↘	14: 10.1	↑	24: 10.1	↑	15: 9.8	←	25: 9.2	←	16: 9.3	↑	26: 10.1	↗	17: 10.1	↘	27: 9.7	←	18: 9.7	↑	28: 10.0	↘	19: 9.8	←	29: 9.2	←	20: 9.4	←	30: 8.2	↘	<b>Serie 92.0</b>		<b>Serie 95.0</b>		<b>Total 182.0</b>		<b>Total 277.0</b>	
11: 9.8	↗	21: *10.6	↘																																															
12: 9.8	→	22: 10.1	↗																																															
13: 9.8	→	23: 10.1	↘																																															
14: 10.1	↑	24: 10.1	↑																																															
15: 9.8	←	25: 9.2	←																																															
16: 9.3	↑	26: 10.1	↗																																															
17: 10.1	↘	27: 9.7	←																																															
18: 9.7	↑	28: 10.0	↘																																															
19: 9.8	←	29: 9.2	←																																															
20: 9.4	←	30: 8.2	↘																																															
<b>Serie 92.0</b>		<b>Serie 95.0</b>																																																
<b>Total 182.0</b>		<b>Total 277.0</b>																																																

<p>40 Skott</p>	<table style="width:100%; border-collapse: collapse;"> <tr><td>31: 9.2</td><td>↗</td></tr> <tr><td>32: *10.4</td><td>→</td></tr> <tr><td>33: *10.6</td><td>↘</td></tr> <tr><td>34: 8.6</td><td>↑</td></tr> <tr><td>35: 8.6</td><td>↘</td></tr> <tr><td>36: 8.6</td><td>↘</td></tr> <tr><td>37: 9.0</td><td>→</td></tr> <tr><td>38: 9.4</td><td>↙</td></tr> <tr><td>39: *10.2</td><td>↑</td></tr> <tr><td>40: 8.2</td><td>↘</td></tr> <tr><td colspan="2"><b>Serie 89.0</b></td></tr> <tr><td colspan="2"><b>Total 366.0</b></td></tr> </table>	31: 9.2	↗	32: *10.4	→	33: *10.6	↘	34: 8.6	↑	35: 8.6	↘	36: 8.6	↘	37: 9.0	→	38: 9.4	↙	39: *10.2	↑	40: 8.2	↘	<b>Serie 89.0</b>		<b>Total 366.0</b>		
31: 9.2	↗																									
32: *10.4	→																									
33: *10.6	↘																									
34: 8.6	↑																									
35: 8.6	↘																									
36: 8.6	↘																									
37: 9.0	→																									
38: 9.4	↙																									
39: *10.2	↑																									
40: 8.2	↘																									
<b>Serie 89.0</b>																										
<b>Total 366.0</b>																										

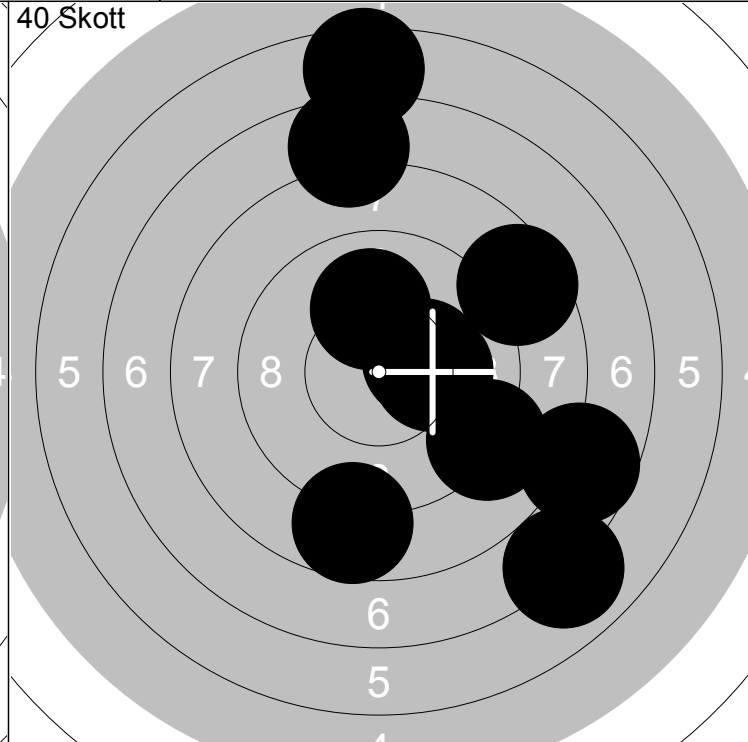
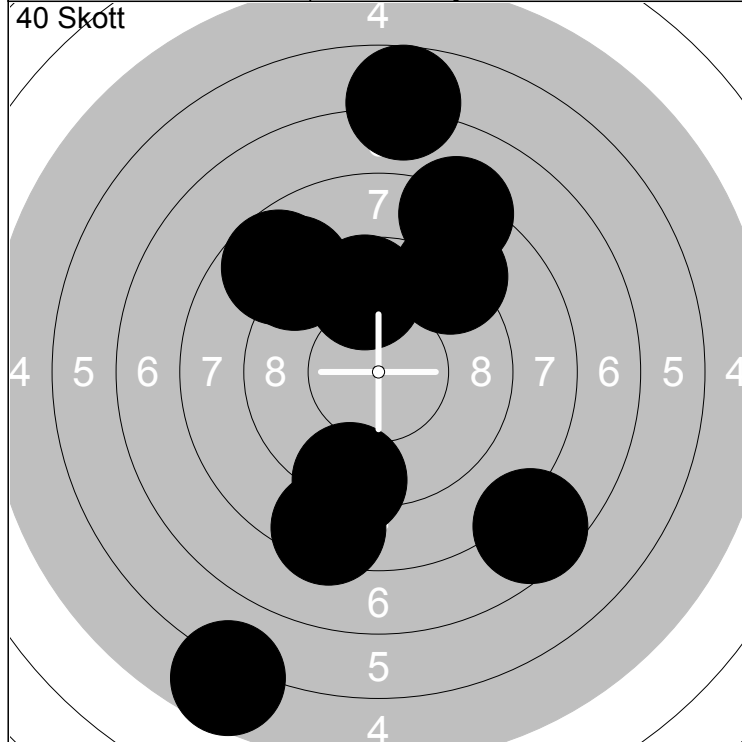

1: 8.4 ↓	6: 6.7 ↑	Serie	77.0
2: 5.6 ↓	7: 8.9 ↖		
3: 9.2 ↓	8: 9.1 ↗	Total	77.0
4: 8.2 ↗	9: 8.7 ↖		
5: 7.6 ↓	10: 9.7 ↑		

11: 7.6 ↑	16: 10.1 →	Serie	82.0
12: 8.7 ↓	17: 10.0 ↑		
13: 9.1 ↘	18: *10.3 →	Total	159.0
14: 8.5 ↗	19: 7.0 ↓		
15: 6.4 ↑	20: 7.7 ↘		

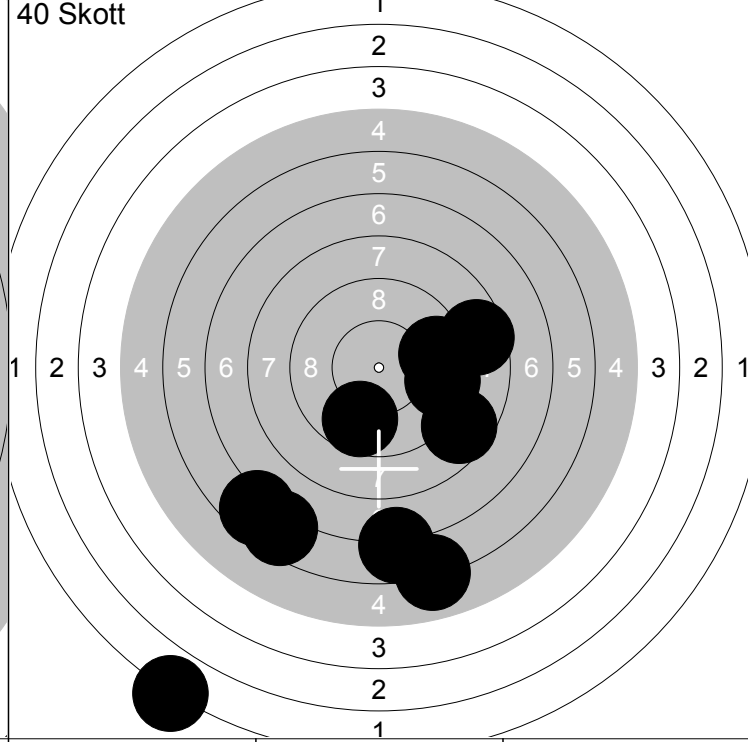
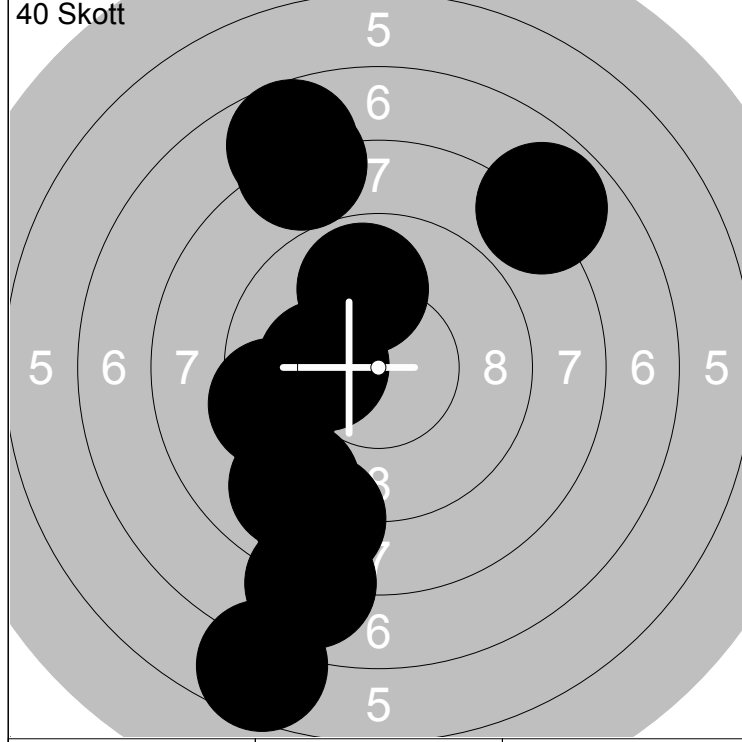

21: 7.9 ↓	26: 6.6 ↓	Serie	80.0
22: 8.7 ↓	27: 7.8 ↗		
23: *10.2 ←	28: 8.0 ↑	Total	239.0
24: 9.0 ↓	29: 9.4 ←		
25: 7.7 ↑	30: 9.9 ↑		

31: 9.7 ↓	36: 1.8 ↓	Serie	68.0
32: 6.6 ↓	37: 9.4 →		
33: 8.5 →	38: 8.6 ↓	Total	307.0
34: 9.6 →	39: 6.7 ↓		
35: 6.5 ↓	40: 6.0 ↓		

<p>Prov</p>	<p>40 Skott</p>	<table style="width:100%; border-collapse: collapse;"> <tr><td>1: 9.6 ↙</td><td>1: *10.6 ↘</td></tr> <tr><td>2: 9.2 ↓</td><td>2: 9.9 ↗</td></tr> <tr><td>3: 9.9 ↓</td><td>3: *10.8 ↘</td></tr> <tr><td>4: *10.2 ↘</td><td>4: *10.2 ↗</td></tr> <tr><td>5: *10.6 ↘</td><td>5: 9.7 ↓</td></tr> <tr><td>6: 9.3 ↗</td><td>6: *10.8 ↘</td></tr> <tr><td>7: *10.7 ↗</td><td>7: *10.4 →</td></tr> <tr><td>8: *10.5 ↘</td><td>8: *10.3 →</td></tr> <tr><td></td><td>9: *10.5 ↓</td></tr> <tr><td></td><td>10: 10.1 ↓</td></tr> <tr><td style="border-top: 1px solid black;">Serie</td><td style="border-top: 1px solid black;">76.0</td></tr> <tr><td style="border-top: 1px solid black;">Total</td><td style="border-top: 1px solid black;">0.0</td></tr> </table>	1: 9.6 ↙	1: *10.6 ↘	2: 9.2 ↓	2: 9.9 ↗	3: 9.9 ↓	3: *10.8 ↘	4: *10.2 ↘	4: *10.2 ↗	5: *10.6 ↘	5: 9.7 ↓	6: 9.3 ↗	6: *10.8 ↘	7: *10.7 ↗	7: *10.4 →	8: *10.5 ↘	8: *10.3 →		9: *10.5 ↓		10: 10.1 ↓	Serie	76.0	Total	0.0
1: 9.6 ↙	1: *10.6 ↘																									
2: 9.2 ↓	2: 9.9 ↗																									
3: 9.9 ↓	3: *10.8 ↘																									
4: *10.2 ↘	4: *10.2 ↗																									
5: *10.6 ↘	5: 9.7 ↓																									
6: 9.3 ↗	6: *10.8 ↘																									
7: *10.7 ↗	7: *10.4 →																									
8: *10.5 ↘	8: *10.3 →																									
	9: *10.5 ↓																									
	10: 10.1 ↓																									
Serie	76.0																									
Total	0.0																									

<p>40 Skott</p>	<p>40 Skott</p>	<table style="width:100%; border-collapse: collapse;"> <tr><td>11: 8.5 →</td><td>21: *10.6 →</td></tr> <tr><td>12: *10.3 ↘</td><td>22: *10.2 ↓</td></tr> <tr><td>13: 9.2 ←</td><td>23: *10.7 ↓</td></tr> <tr><td>14: 10.0 ↘</td><td>24: *10.6 ↘</td></tr> <tr><td>15: *10.3 →</td><td>25: *10.5 →</td></tr> <tr><td>16: *10.4 ↘</td><td>26: *10.4 ↘</td></tr> <tr><td>17: *10.6 →</td><td>27: *10.8 ↗</td></tr> <tr><td>18: *10.2 ↘</td><td>28: *10.3 ↗</td></tr> <tr><td>19: 9.9 ↗</td><td>29: 10.1 ↑</td></tr> <tr><td>20: 9.7 ↗</td><td>30: *10.7 ↘</td></tr> <tr><td style="border-top: 1px solid black;">Serie</td><td style="border-top: 1px solid black;">95.0</td></tr> <tr><td style="border-top: 1px solid black;">Total</td><td style="border-top: 1px solid black;">193.0</td></tr> </table>	11: 8.5 →	21: *10.6 →	12: *10.3 ↘	22: *10.2 ↓	13: 9.2 ←	23: *10.7 ↓	14: 10.0 ↘	24: *10.6 ↘	15: *10.3 →	25: *10.5 →	16: *10.4 ↘	26: *10.4 ↘	17: *10.6 →	27: *10.8 ↗	18: *10.2 ↘	28: *10.3 ↗	19: 9.9 ↗	29: 10.1 ↑	20: 9.7 ↗	30: *10.7 ↘	Serie	95.0	Total	193.0
11: 8.5 →	21: *10.6 →																									
12: *10.3 ↘	22: *10.2 ↓																									
13: 9.2 ←	23: *10.7 ↓																									
14: 10.0 ↘	24: *10.6 ↘																									
15: *10.3 →	25: *10.5 →																									
16: *10.4 ↘	26: *10.4 ↘																									
17: *10.6 →	27: *10.8 ↗																									
18: *10.2 ↘	28: *10.3 ↗																									
19: 9.9 ↗	29: 10.1 ↑																									
20: 9.7 ↗	30: *10.7 ↘																									
Serie	95.0																									
Total	193.0																									

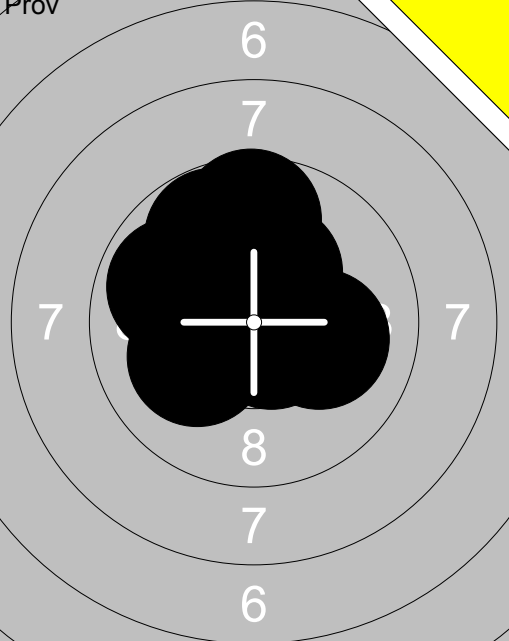
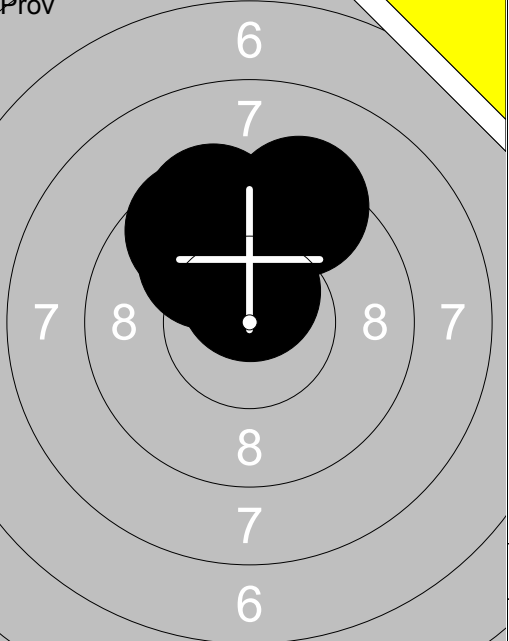

<p>40 Skott</p>		<table style="width:100%; border-collapse: collapse;"> <tr><td>31: *10.6 ↗</td><td></td></tr> <tr><td>32: *10.3 ↑</td><td></td></tr> <tr><td>33: *10.2 ↘</td><td></td></tr> <tr><td>34: 9.7 ←</td><td></td></tr> <tr><td>35: 9.8 ↗</td><td></td></tr> <tr><td>36: *10.6 ↘</td><td></td></tr> <tr><td>37: 9.6 →</td><td></td></tr> <tr><td>38: *10.2 ↘</td><td></td></tr> <tr><td>39: *10.5 ↘</td><td></td></tr> <tr><td>40: *10.2 ↓</td><td></td></tr> <tr><td style="border-top: 1px solid black;">Serie</td><td style="border-top: 1px solid black;">97.0</td></tr> <tr><td style="border-top: 1px solid black;">Total</td><td style="border-top: 1px solid black;">390.0</td></tr> </table>	31: *10.6 ↗		32: *10.3 ↑		33: *10.2 ↘		34: 9.7 ←		35: 9.8 ↗		36: *10.6 ↘		37: 9.6 →		38: *10.2 ↘		39: *10.5 ↘		40: *10.2 ↓		Serie	97.0	Total	390.0
31: *10.6 ↗																										
32: *10.3 ↑																										
33: *10.2 ↘																										
34: 9.7 ←																										
35: 9.8 ↗																										
36: *10.6 ↘																										
37: 9.6 →																										
38: *10.2 ↘																										
39: *10.5 ↘																										
40: *10.2 ↓																										
Serie	97.0																									
Total	390.0																									

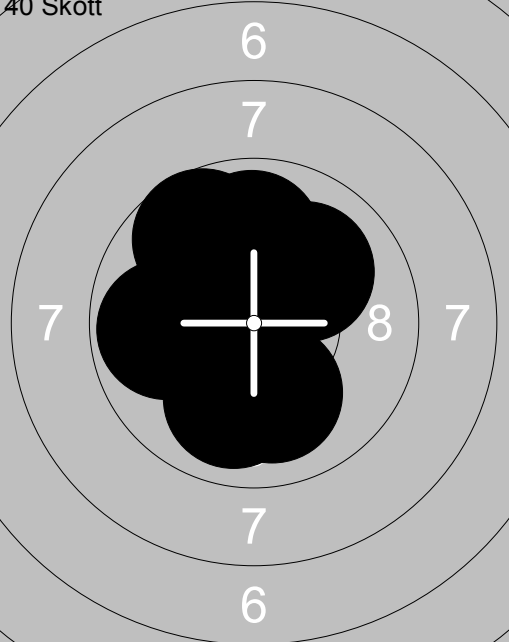
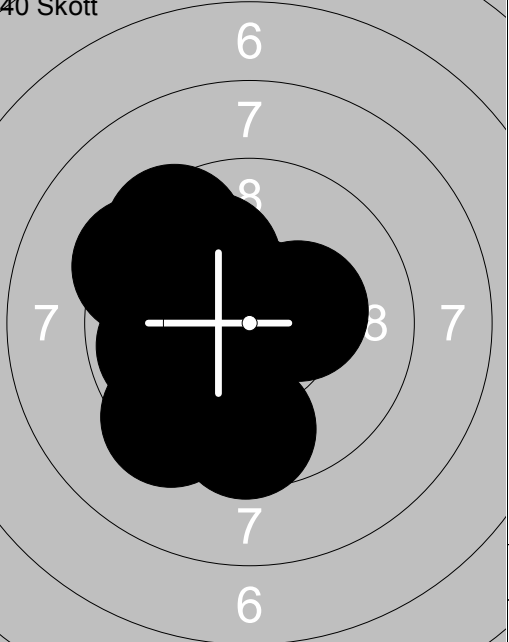
<p>Prov</p> 	<p>1: 9.9 ↙                  2: *10.3 ↗                  3: 10.1 →                  4: *10.5 ↗                  5: 9.8 ↗                  6: *10.8 ↗                  7: *10.2 ↘                  8: 10.1 ↙                  9: *10.6 ↘                  10: 9.6 ↑</p> <p>Serie 97.0 Total 0.0</p>	<p>Prov</p> 	<p>11: 9.3 ↗                  12: 10.0 ↘                  13: 9.5 ↗                  14: 9.6 ↘                  15: *10.2 ↗                  16: *10.5 ↗</p> <p>Serie 57.0 Total 0.0</p>
--	--	--	--

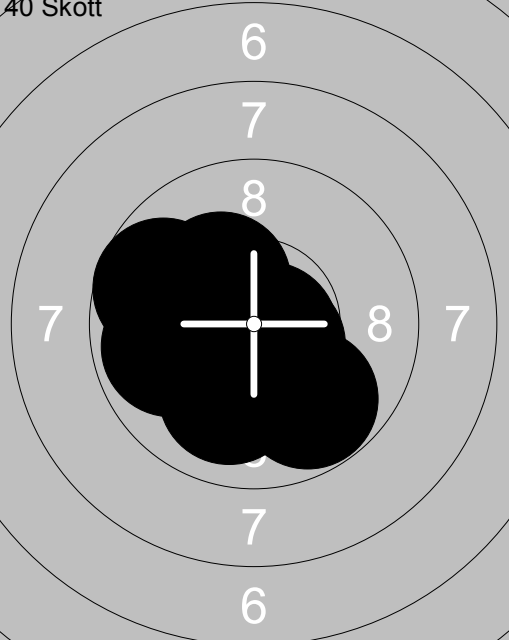
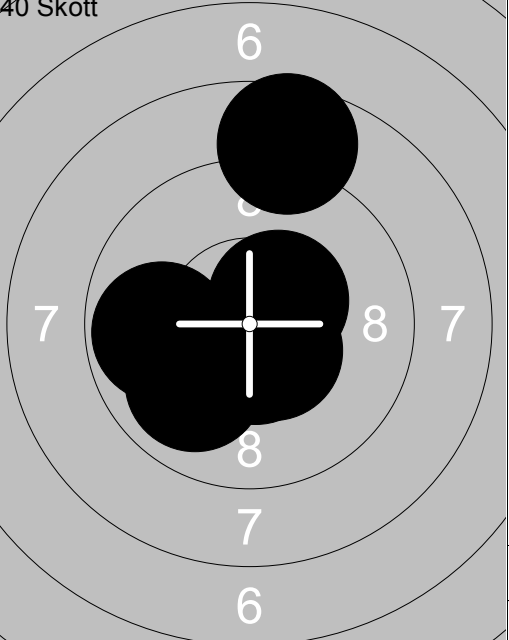
<p>40 Skott</p> 	<p>1: *10.2 ↗                  2: 9.9 ↑                  3: *10.5 ↘                  4: *10.3 ↘                  5: 10.0 ↓                  6: 10.0 ↗                  7: 9.8 ←                  8: 10.0 ↓                  9: 9.7 ↗                  10: *10.4 ↗</p> <p>Serie 97.0 Total 97.0</p>	<p>40 Skott</p> 	<p>11: *10.3 →                  12: *10.6 ↘                  13: 9.6 ↘                  14: 9.5 ↗                  15: 10.0 ↗                  16: 9.4 ↘                  17: 9.4 ↘                  18: 9.9 ←                  19: 9.6 ↓                  20: *10.2 ↘</p> <p>Serie 94.0 Total 191.0</p>
---	--	---	--

<p>40 Skott</p> 	<p>21: *10.7 ↘                  22: *10.3 ↘                  23: 10.0 ↓                  24: 9.9 ←                  25: 9.8 ↓                  26: *10.6 ↘                  27: *10.3 ↘                  28: *10.4 ←                  29: 9.7 ↘                  30: *10.6 ↘</p> <p>Serie 97.0 Total 288.0</p>	<p>40 Skott</p> 	<p>31: 9.9 ↘                  32: *10.4 ↘                  33: *10.3 ↘                  34: 10.1 ←                  35: *10.5 ↘                  36: *10.4 ↘                  37: *10.5 ↗                  38: 9.8 ←                  39: 8.6 ↑                  40: *10.6 ↘</p> <p>Serie 96.0 Total 384.0</p>
--	--	--	--

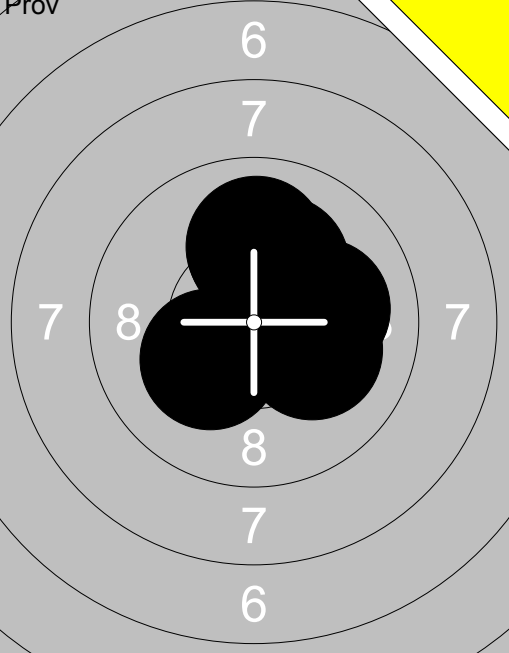
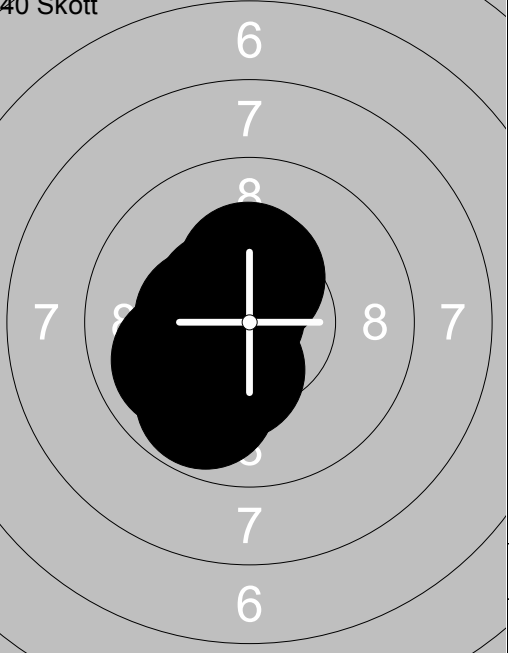

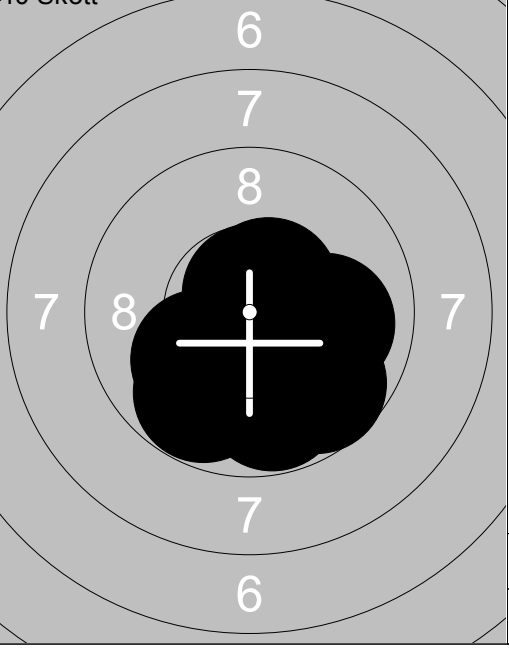
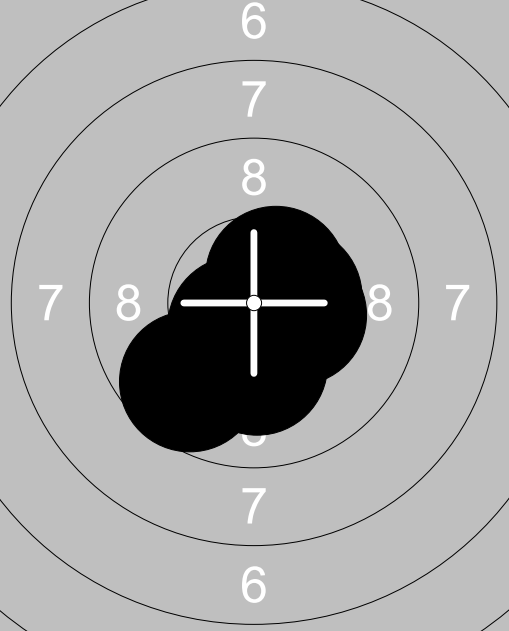
<p>Prov</p> 	<p>40 Skott</p> 	<p>1: 10.1 →</p> <p>2: 10.1 →</p> <p>3: *10.2 ↗</p> <p>4: *10.2 ↘</p> <p>5: *10.6 →</p> <p>6: 10.0 ↑</p> <p>7: *10.4 ↗</p> <p>8: *10.6 ↗</p> <p>9: 10.0 ↑</p> <p>10: *10.7 →</p> <hr/> <p>Serie 100.0</p> <p>Total 0.0</p>	<p>1: *10.4 ←</p> <p>2: *10.4 ↗</p> <p>3: *10.3 ↗</p> <p>4: *10.4 ←</p> <p>5: *10.3 ↘</p> <p>6: *10.7 ↘</p> <p>7: 10.0 ↘</p> <p>8: *10.5 ↘</p> <p>9: *10.4 ←</p> <p>10: 9.8 ↘</p> <hr/> <p>Serie 99.0</p> <p>Total 99.0</p>
<p>40 Skott</p> 	<p>40 Skott</p> 	<p>11: 9.6 ←</p> <p>12: 10.1 ↓</p> <p>13: 9.9 ←</p> <p>14: *10.6 ↘</p> <p>15: 10.1 ↓</p> <p>16: 10.1 ↓</p> <p>17: *10.2 →</p> <p>18: *10.6 ↘</p> <p>19: 9.7 ↗</p> <p>20: *10.7 →</p> <hr/> <p>Serie 97.0</p> <p>Total 196.0</p>	<p>21: *10.7 ↗</p> <p>22: 10.0 →</p> <p>23: *10.4 ↘</p> <p>24: *10.6 ↗</p> <p>25: 10.1 ↘</p> <p>26: 10.0 ↓</p> <p>27: *10.8 ↘</p> <p>28: 9.7 ↘</p> <p>29: 9.8 ↘</p> <p>30: 9.8 ↘</p> <hr/> <p>Serie 97.0</p> <p>Total 293.0</p>
<p>40 Skott</p> 	<p>31: *10.2 ↓</p> <p>32: 9.7 ↘</p> <p>33: *10.4 →</p> <p>34: *10.5 ↗</p> <p>35: *10.6 ↘</p> <p>36: *10.6 →</p> <p>37: *10.5 →</p> <p>38: *10.6 ↓</p> <p>39: *10.3 ↘</p> <p>40: *10.6 ↘</p> <hr/> <p>Serie 99.0</p> <p>Total 392.0</p>		

<p>Prov</p>	<p>Prov</p>
Serie 76.0	Serie 85.0
Total 0.0	Total 0.0

<p>40 Skott</p>	<p>40 Skott</p>
Serie 84.0	Serie 69.0
Total 84.0	Total 153.0

<p>40 Skott</p>	<p>40 Skott</p>
Serie 55.0	Serie 77.0
Total 208.0	Total 285.0

<p>Prov</p>	<p>1: 3.4 ↘ 2: 9.0 ↘ 3: 8.1 ↓ 4: 9.1 ↓ 5: 8.2 ↗ 6: 8.3 → 7: 8.2 → 8: *10.7 ↗ 9: 8.2 ↘ 10: 8.9 ↗</p> <p>Serie 79.0 Total 0.0</p>	<p>Prov</p>	<p>11: 8.0 ↘ 12: *10.2 ↘ 13: 10.0 ↘ 14: 10.1 ↘ 15: 10.0 ↘ 16: 9.7 → 17: 9.7 ← 18: 9.6 ↘ 19: 3.7 ↓ 20: *10.5 ↘</p> <p>Serie 88.0 Total 0.0</p>
-------------	---	-------------	---

<p>40 Skott</p>	<p>1: 10.1 ← 2: 9.6 ↓ 3: 9.4 ← 4: 8.9 ↗ 5: 8.5 → 6: *10.3 ↘ 7: 8.4 ↘ 8: 9.0 → 9: 10.0 ↓ 10: 9.4 ↗</p> <p>Serie 90.0 Total 90.0</p>	<p>40 Skott</p>	<p>11: 7.9 ↘ 12: 9.8 ← 13: 10.1 ← 14: 9.3 ↗ 15: 9.9 ↘ 16: 9.4 ↓ 17: 8.2 ↘ 18: 7.7 ↑ 19: 9.0 ↗ 20: *10.4 ↘</p> <p>Serie 87.0 Total 177.0</p>
-----------------	--	-----------------	---

<p>40 Skott</p>	<p>21: 8.2 ↗ 22: 9.2 ↗ 23: 9.1 → 24: 8.8 ← 25: 10.0 ← 26: 9.5 ↗ 27: 9.2 → 28: 9.1 ← 29: 9.9 ↑ 30: *10.5 ↘</p> <p>Serie 90.0 Total 267.0</p>	<p>40 Skott</p>	<p>31: 9.9 ↑ 32: 8.2 ↗ 33: *10.2 ↘ 34: 9.3 ↑ 35: *10.7 ↗ 36: *10.2 ↗ 37: 0.0 ← 38: 8.9 ↗ 39: 10.0 ↘ 40: 9.9 →</p> <p>Serie 83.0 Total 350.0</p>
-----------------	---	-----------------	---

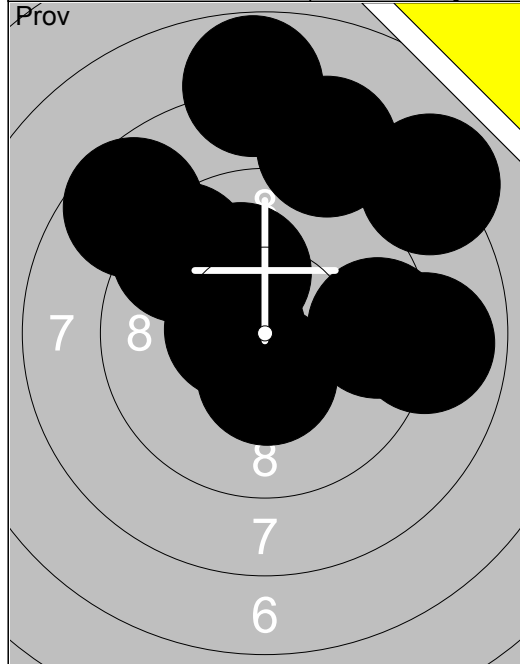

1:	8.1	↗
2:	8.4	↑
3:	7.8	↑
4:	8.9	→
5:	*10.4	↓
6:	9.5	→
7:	8.6	↖
8:	*10.6	←
9:	9.5	↖
10:	10.1	↗
Serie		87.0
Total		0.0

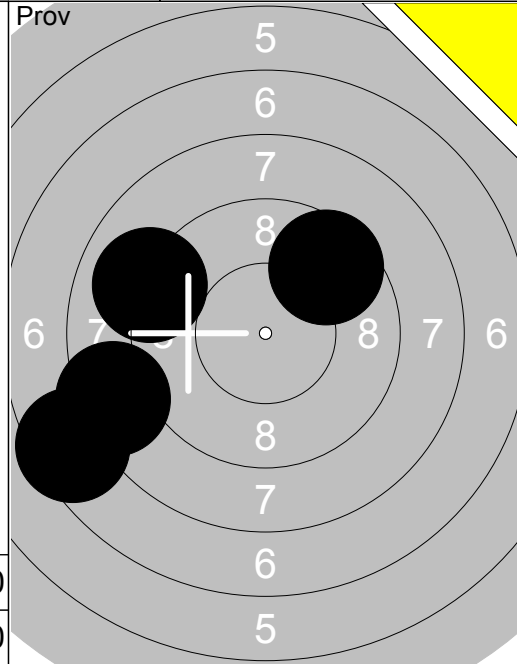

11:	9.6	↗
12:	7.5	↙
13:	8.4	↙
14:	9.0	↙
Serie		33.0
Total		0.0

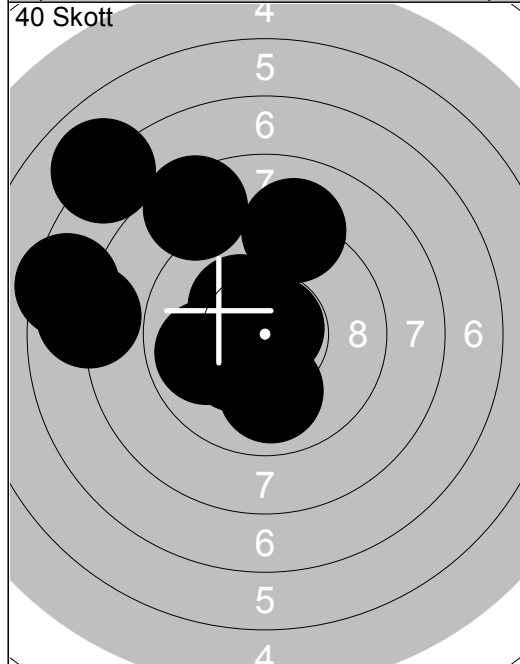

1:	*10.8	↗
2:	9.9	←
3:	7.0	↖
4:	*10.3	↙
5:	8.5	↑
6:	7.4	←
7:	10.0	↓
8:	7.9	←
9:	*10.3	↖
10:	9.1	↑
Serie		87.0
Total		87.0

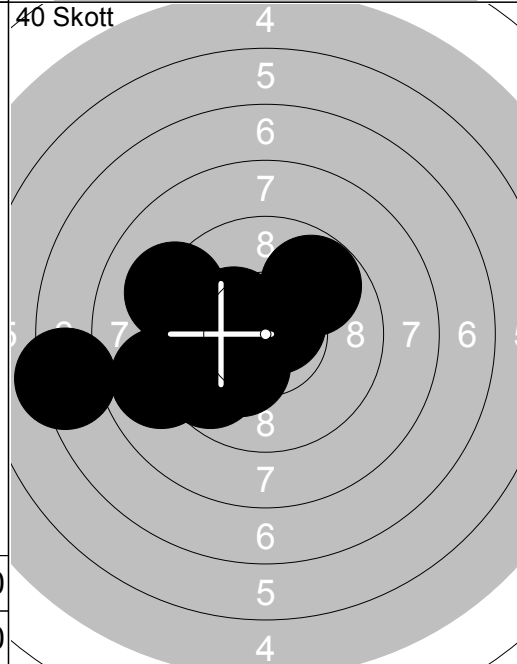

11:	10.1	←
12:	9.8	↗
13:	7.3	←
14:	8.9	←
15:	9.7	←
16:	*10.2	↙
17:	9.2	↖
18:	*10.7	↗
19:	*10.3	↖
20:	9.7	↙
Serie		91.0
Total		178.0

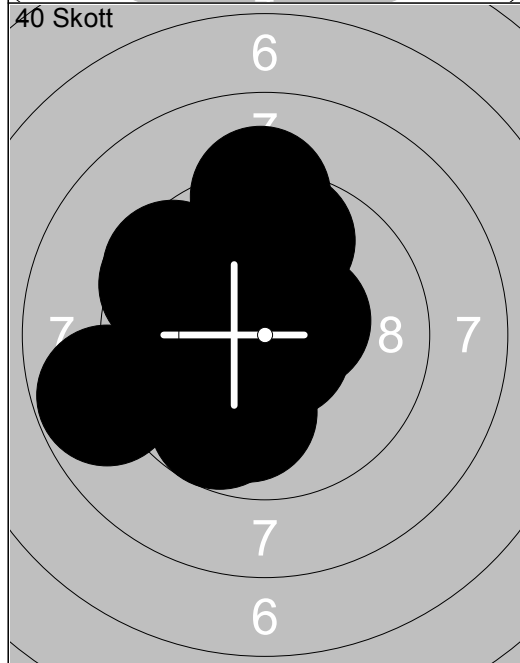

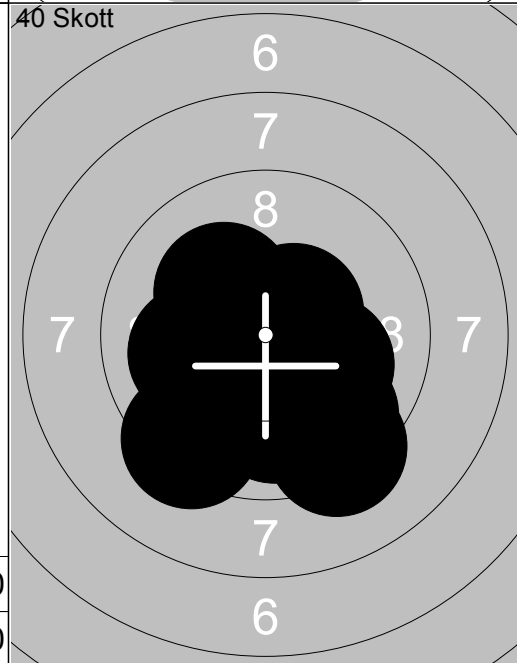

21:	9.7	↙
22:	9.2	↑
23:	9.5	↖
24:	8.8	←
25:	9.9	↓
26:	*10.5	↗
27:	*10.7	↘
28:	9.6	↖
29:	9.9	↙
30:	9.7	↑
Serie		91.0
Total		269.0

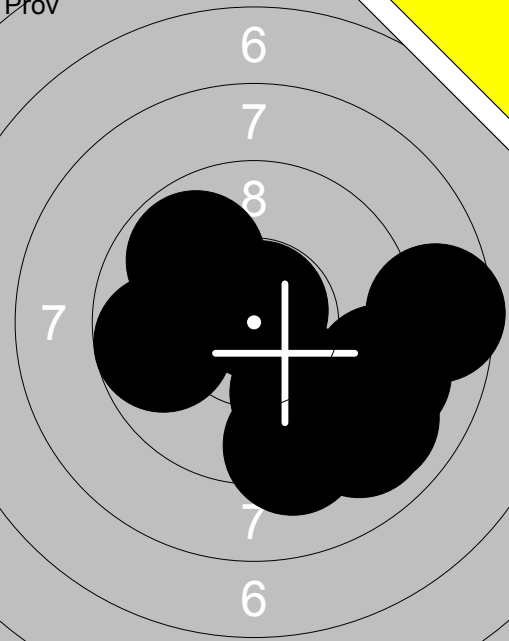
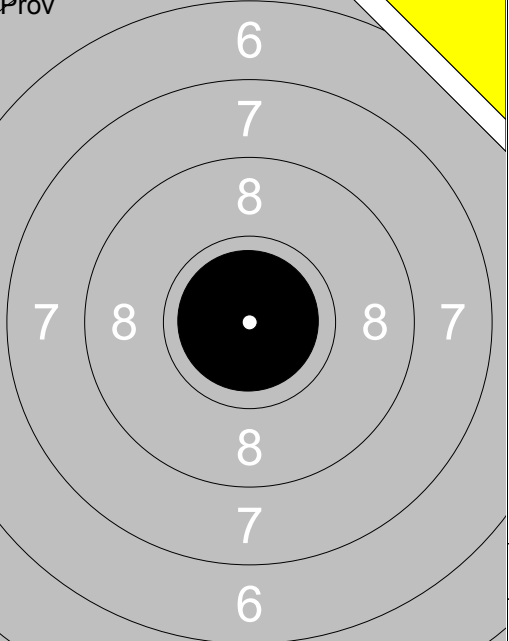

31:	10.0	↓
32:	*10.4	↖
33:	9.3	↓
34:	*10.5	↘
35:	10.1	←
36:	*10.2	↖
37:	10.1	→
38:	9.3	↙
39:	9.6	↓
40:	*10.5	↗
Serie		97.0
Total		366.0

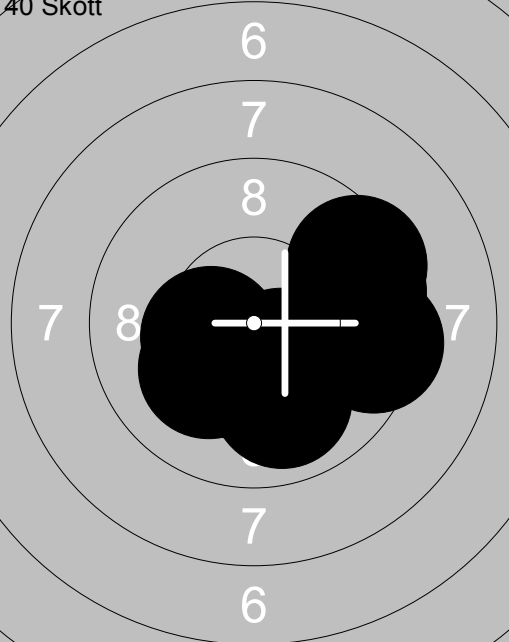
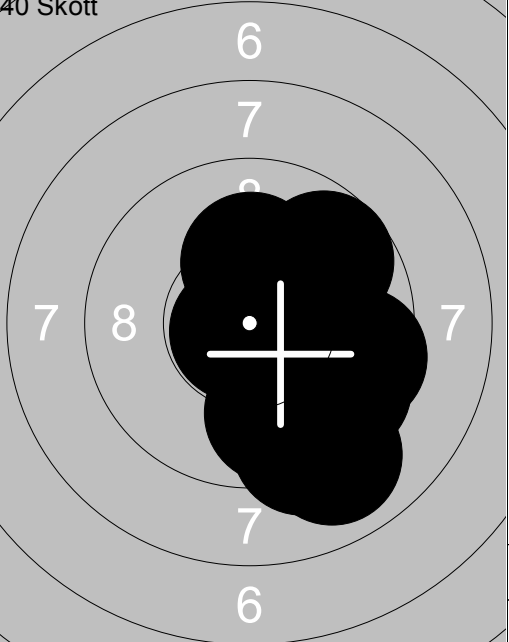
	1: 9.2 →		11: *10.9 ↘
	2: 8.6 →		
	3: 9.3 ↓		
	4: 9.9 ↓		
	5: 9.0 ↓		
	6: 9.0 ↓		
	7: 9.2 ↓		
	8: 9.7 ←		
	9: 9.8 ↗		
	10: *10.8 ↗		
	Serie 90.0		Serie 10.0
	Total 0.0		Total 0.0

	1: 9.4 →		11: 9.8 ↓
	2: 9.6 →		12: 9.8 ↓
	3: *10.4 ↘		13: 9.3 ↓
	4: *10.3 ↓		14: 9.5 →
	5: 10.1 ↘		15: 9.5 ↓
	6: 9.8 →		16: 9.0 ↓
	7: 9.4 ↗		17: 9.7 ↗
	8: 9.9 ↓		18: *10.2 →
	9: *10.3 ↓		19: *10.2 ↗
	10: *10.4 ↓		20: *10.8 ↘
	Serie 95.0		Serie 93.0
	Total 95.0		Total 188.0

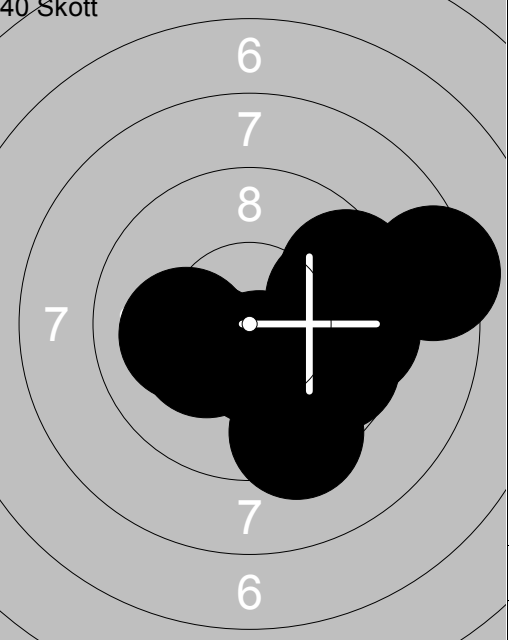
	21: 9.4 →		31: 9.7 →
	22: *10.4 ↓		32: 9.4 ↓
	23: *10.3 ↘		33: 8.4 →
	24: 10.1 →		34: 9.6 →
	25: 9.4 ↓		35: 9.5 ↗
	26: *10.4 ↓		36: *10.3 ↘
	27: 9.7 →		37: 9.5 →
	28: *10.4 ↓		38: 9.8 →
	29: 8.4 →		39: 10.1 ←
	30: 8.8 ↓		40: *10.5 ↓
	Serie 93.0		Serie 92.0
	Total 281.0		Total 373.0

<p>Prov</p>	<p>1: 10.0 →</p> <p>2: 10.0 →</p> <p>3: *10.2 ↑</p> <p>4: 10.0 ↑</p> <p>5: 9.9 ↑</p> <p>6: 9.8 ↓</p> <p>7: *10.7 ↖</p> <p>8: 9.7 ↓</p> <p>9: 9.8 ↓</p> <p>10: 10.0 ↓</p>	<p>Prov</p>	<p>11: *10.4 ↖</p>
Serie	96.0	Serie	10.0
Total	0.0	Total	0.0

<p>40 Skott</p>	<p>1: *10.2 ↓</p> <p>2: *10.7 ↓</p> <p>3: 8.3 ↓</p> <p>4: 9.9 ↑</p> <p>5: 9.8 ↑</p> <p>6: *10.2 ↖</p> <p>7: 9.6 ↑</p> <p>8: *10.3 →</p> <p>9: 9.5 ←</p> <p>10: 9.2 ←</p>	<p>40 Skott</p>	<p>11: 9.4 ←</p> <p>12: 9.8 ←</p> <p>13: 9.5 ↓</p> <p>14: *10.3 ↖</p> <p>15: 9.8 ↖</p> <p>16: 8.7 →</p> <p>17: 8.7 ↗</p> <p>18: 9.9 ↓</p> <p>19: 10.0 ↗</p> <p>20: 9.0 →</p>
Serie	93.0	Serie	90.0
Total	93.0	Total	183.0

<p>40 Skott</p>	<p>21: *10.4 →</p> <p>22: *10.4 ↑</p> <p>23: 10.0 →</p> <p>24: 9.9 ↑</p> <p>25: 8.8 ↑</p> <p>26: 7.1 ↑</p> <p>27: 10.1 ↓</p> <p>28: 10.0 →</p> <p>29: *10.6 ↑</p> <p>30: 10.1 ↑</p>	<p>40 Skott</p>	<p>31: 10.1 ↑</p> <p>32: 9.9 →</p> <p>33: 8.9 →</p> <p>34: 9.8 ↓</p> <p>35: *10.3 ↓</p> <p>36: 9.1 ↓</p> <p>37: *10.4 →</p> <p>38: *10.2 ↖</p> <p>39: 10.1 ↗</p> <p>40: *10.7 ↓</p>
Serie	94.0	Serie	95.0
Total	277.0	Total	372.0



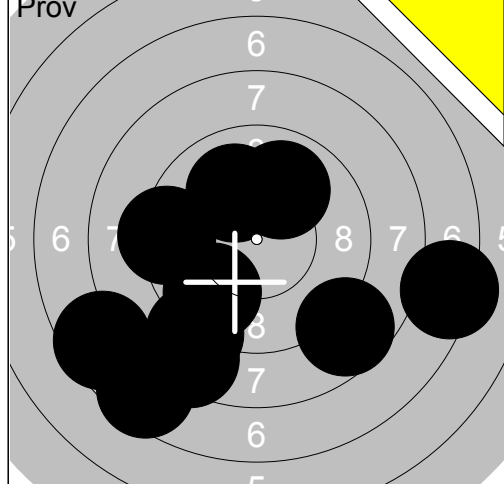

1:	8.7	↘
2:	7.3	→
3:	7.6	↙
4:	7.5	↘
5:	8.9	↘
6:	9.9	↗
7:	9.7	↘
8:	9.3	←
9:	8.4	↘
10:	10.0	↗

Serie	82.0
Total	0.0

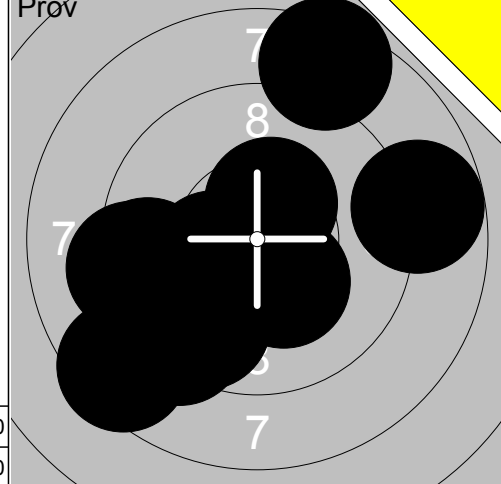

11:	9.6	↘
12:	9.4	←
13:	9.3	↘
14:	8.8	→
15:	*10.4	↗
16:	9.2	←
17:	*10.3	←
18:	8.5	↘
19:	8.4	↗
20:	*10.3	↘

Serie	90.0
Total	0.0

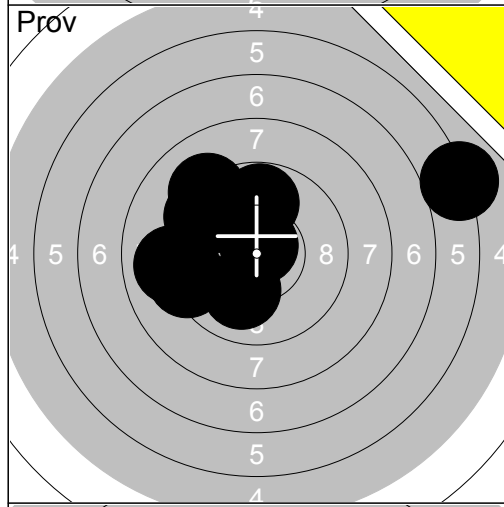

21:	9.8	↗
22:	9.3	←
23:	6.0	→
24:	*10.8	↗
25:	9.5	↗
26:	10.1	↘
27:	9.2	↗
28:	9.0	←

Serie	71.0
Total	0.0

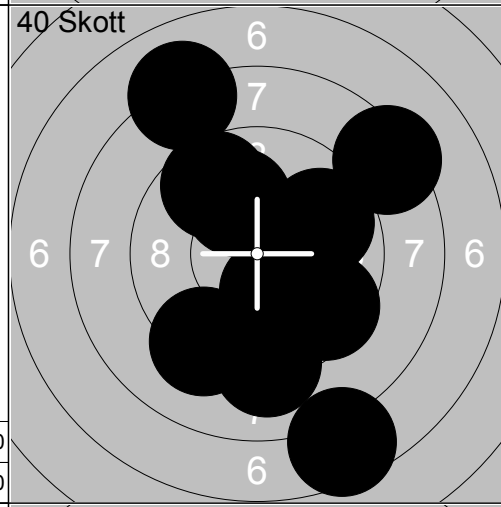

1:	9.1	↘
2:	*10.3	↘
3:	8.3	↗
4:	8.1	↗
5:	9.2	↘
6:	9.6	↗
7:	9.5	↘
8:	10.0	↗
9:	7.5	↘
10:	9.8	↗

Serie	88.0
Total	88.0

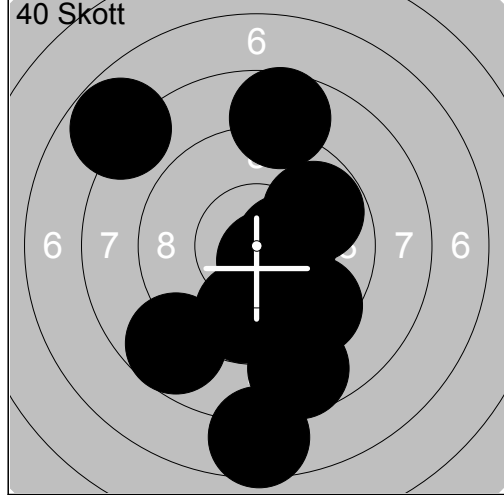

11:	*10.4	→
12:	8.7	↘
13:	9.8	↗
14:	9.5	↘
15:	7.8	↗
16:	9.8	↘
17:	8.7	↗
18:	7.6	↘
19:	8.7	↘
20:	*10.6	↘

Serie	85.0
Total	173.0

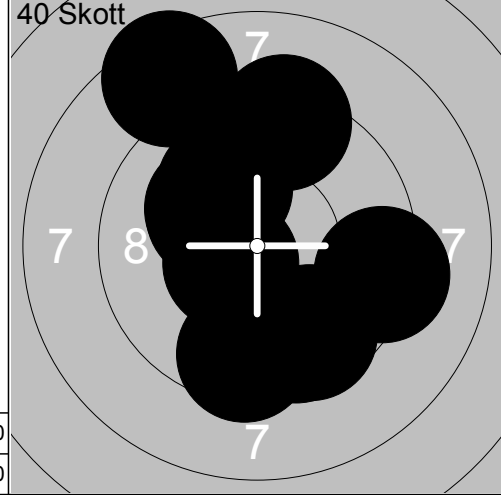

21:	9.6	↘
22:	9.5	↘
23:	9.3	↗
24:	9.3	→
25:	9.7	↘
26:	8.5	↗
27:	*10.2	↗
28:	*10.2	↗
29:	10.1	↗
30:	*10.5	↙

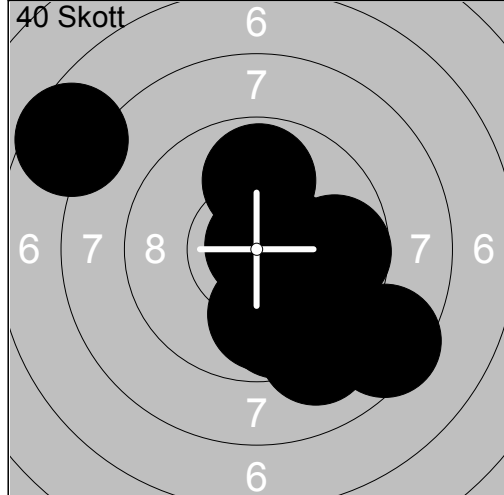

Serie	93.0
Total	266.0



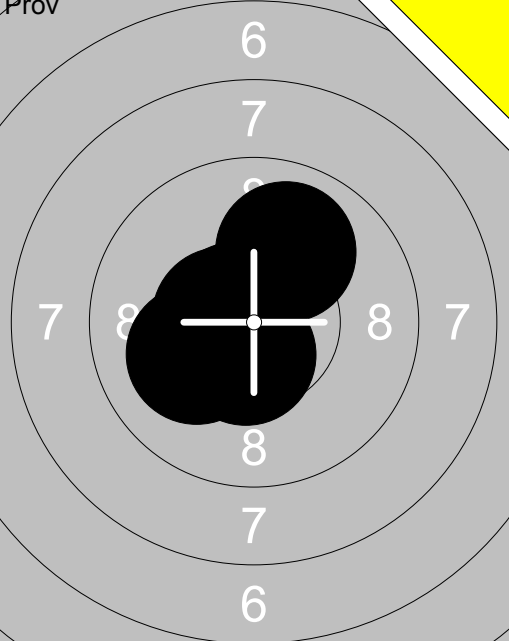
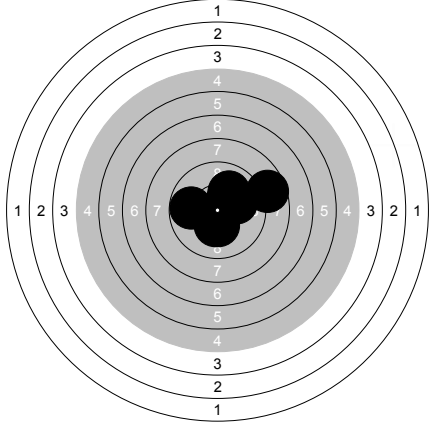

31:	9.7	↘
32:	9.9	↘
33:	*10.5	→
34:	9.7	→
35:	9.9	↗
36:	*10.9	↗
37:	9.1	↘
38:	7.5	↗
39:	8.5	↘
40:	9.7	↘

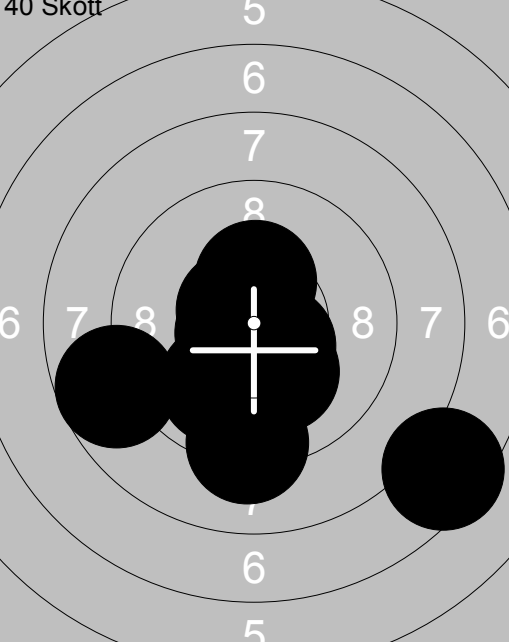
Serie	89.0
Total	355.0

<p>Prov</p> 	<p>40 Skott</p> 	<p>1: *10.7 ↗</p> <p>2: 10.1 ↙</p> <p>3: *10.5 ↖</p> <p>4: 10.0 ↗</p> <p>5: *10.5 ↓</p>	<p>1: *10.3 ↗</p> <p>2: 10.1 →</p> <p>3: *10.9 ↘</p> <p>4: 10.0 ↗</p> <p>5: *10.8 ↓</p> <p>6: *10.3 ↓</p> <p>7: 8.7 →</p> <p>8: 9.8 ←</p> <p>9: *10.3 ↓</p> <p>10: 0.0 →</p>
Serie 50.0		Serie 87.0	
Total 0.0		Total 87.0	

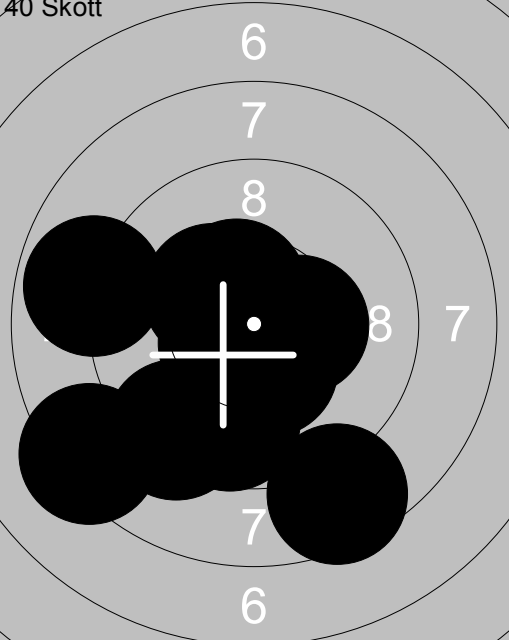
<p>40 Skott</p> 	<p>40 Skott</p> 	<p>11: *10.6 ↖</p> <p>12: 8.7 ↙</p> <p>13: *10.2 ↓</p> <p>14: 7.4 →</p> <p>15: *10.5 ↘</p> <p>16: 9.9 ↓</p> <p>17: *10.5 ↓</p> <p>18: 9.2 ↓</p> <p>19: *10.6 ↖</p> <p>20: *10.3 ↑</p>	<p>21: 9.6 ↓</p> <p>22: 9.7 ↓</p> <p>23: 9.4 →</p> <p>24: *10.3 ↘</p> <p>25: *10.5 ↖</p> <p>26: 8.8 ↓</p> <p>27: 10.0 ←</p> <p>28: *10.7 ↖</p> <p>29: 10.0 →</p> <p>30: 10.0 ←</p>
Serie 93.0		Serie 95.0	
Total 180.0		Total 275.0	

<p>40 Skott</p> 	<p>31: 8.9 ←</p> <p>32: 8.5 ↓</p> <p>33: *10.4 →</p> <p>34: 8.3 ↙</p> <p>35: 9.3 ↙</p> <p>36: *10.3 ↖</p> <p>37: *10.5 ↖</p> <p>38: *10.4 ↓</p> <p>39: *10.5 ↖</p> <p>40: 9.7 ↓</p>		
Serie 92.0			
Total 367.0			

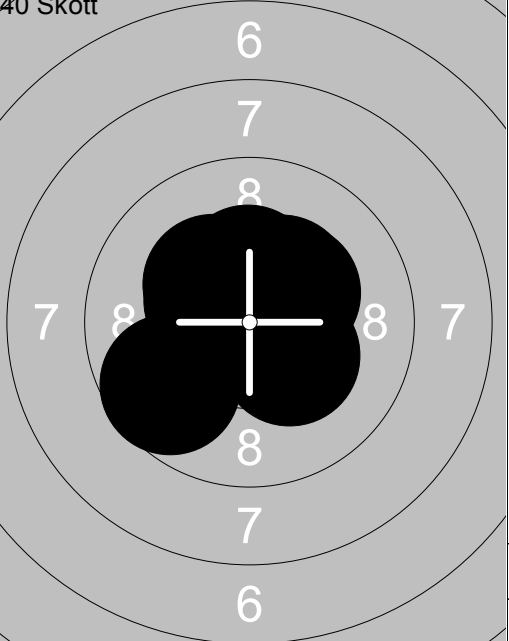

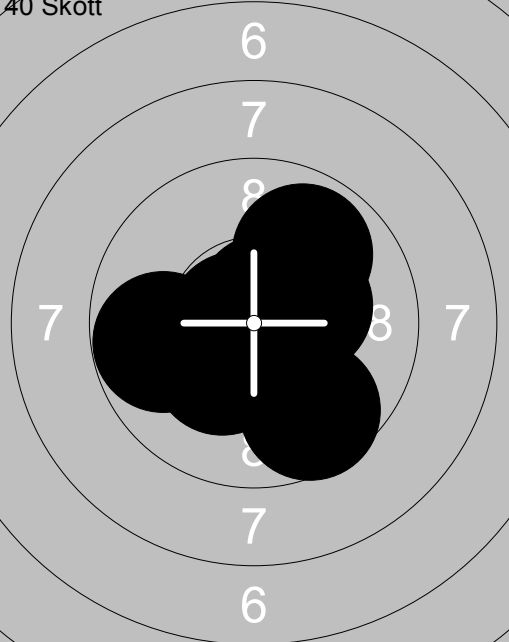
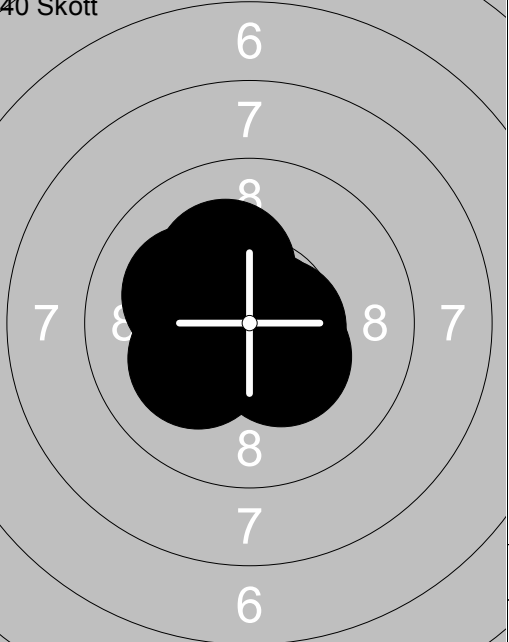
Prov 	1: *10.7 → 2: *10.4 ↑ 3: *10.9 ↘ 4: 10.1 ↑ 5: *10.6 ↘ 6: 10.1 ↗ 7: 9.7 ↖ 8: *10.3 ↓ 9: *10.2 ↖ 10: *10.2 ↗	40 Skott 	1: *10.3 ↖ 2: *10.4 ↖ 3: *10.3 ↗ 4: *10.3 ↗ 5: *10.3 ↘ 6: 9.7 ↖ 7: *10.6 ↑ 8: *10.5 ↗ 9: *10.3 ↑ 10: *10.5 ↖
Serie 99.0		Serie 99.0	
Total 0.0		Total 99.0	

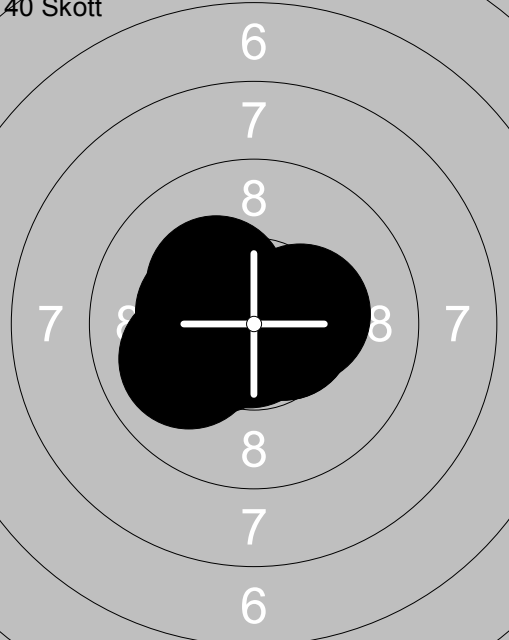
40 Skott 	11: *10.7 ↘ 12: 9.8 ← 13: *10.5 ↘ 14: *10.3 → 15: 9.9 ↗ 16: *10.7 ↖ 17: *10.3 ↘ 18: 9.6 ↓ 19: *10.6 ↘ 20: *10.7 ↗	40 Skott 	21: *10.8 ↘ 22: *10.6 → 23: *10.4 ↘ 24: *10.8 ↓ 25: *10.9 ↑ 26: *10.8 → 27: *10.6 ↖ 28: 10.1 ↖ 29: *10.2 ↗ 30: *10.2 ↘
Serie 97.0		Serie 100.0	
Total 196.0		Total 296.0	

40 Skott 	31: *10.6 → 32: *10.4 ↖ 33: *10.4 ← 34: *10.3 → 35: *10.6 → 36: *10.3 ↖ 37: *10.3 ↖ 38: 10.0 ↖ 39: *10.3 ↖ 40: *10.8 ↓		
Serie 100.0			
Total 396.0			

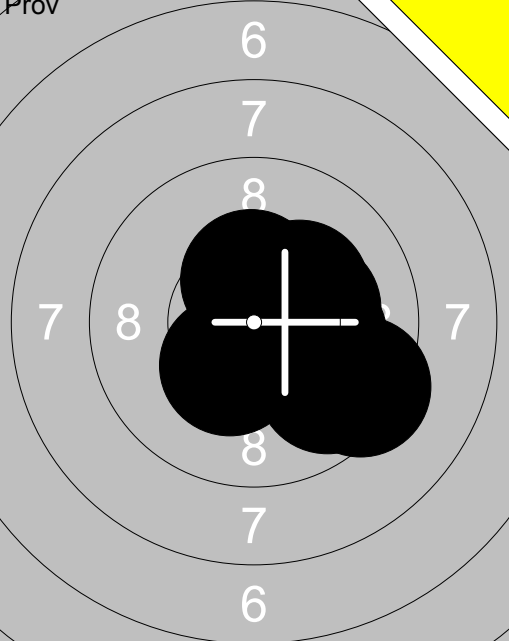
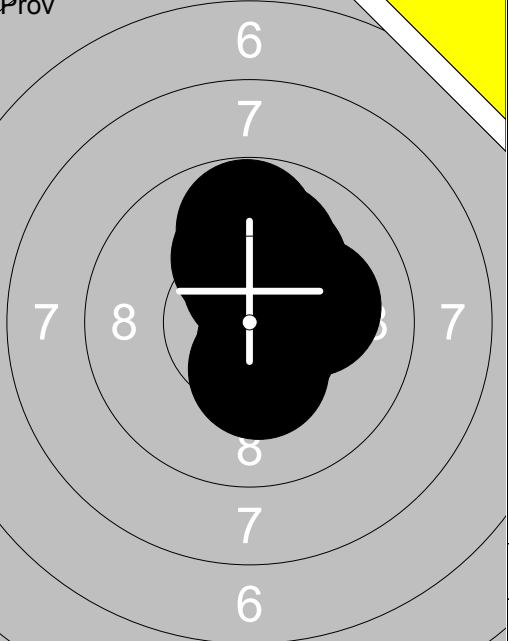
<p>Prov</p>	<p>1: 9.8 ↙                  2: 8.9 ↑                  3: 9.4 ↙                  4: *10.5 →                  5: 10.0 ↑                  6: 9.5 ↑                  7: 10.0 ↙                  8: *10.3 ↙                  9: 9.9 ↙                  10: 9.2 ↗</p> <p>Serie 93.0 Total 0.0</p>	<p>Prov</p>	<p>11: *10.2 ↙                  12: 10.0 ↗                  13: *10.7 ↘</p> <p>Serie 30.0 Total 0.0</p>
<p>40 Skott</p>	<p>1: *10.5 ↘                  2: 9.8 ↓                  3: *10.2 ↓                  4: 9.7 ↙                  5: *10.3 ↘                  6: *10.5 ↘                  7: *10.6 ↘                  8: 10.0 ↓                  9: 9.3 ↓                  10: 10.1 ↑</p> <p>Serie 97.0 Total 97.0</p>	<p>40 Skott</p>	<p>11: 10.1 →                  12: *10.6 ↙                  13: *10.2 ↙                  14: 9.3 ↓                  15: *10.3 →                  16: *10.4 →                  17: *10.2 ↓                  18: 9.6 ↙                  19: 9.6 ↓                  20: *10.2 ↘</p> <p>Serie 97.0 Total 194.0</p>
<p>40 Skott</p>	<p>21: *10.4 ↘                  22: *10.2 ↙                  23: *10.4 ↘                  24: 9.9 ↓                  25: *10.5 ↘                  26: *10.2 →                  27: *10.4 ↓                  28: 8.6 →                  29: 10.0 ↗                  30: *10.3 ↓</p> <p>Serie 97.0 Total 291.0</p>	<p>40 Skott</p>	<p>31: 9.6 ↘                  32: *10.4 ↙                  33: *10.2 ↗                  34: *10.2 ↙                  35: 9.2 ↗                  36: 9.6 ↘                  37: 9.9 ↘                  38: 9.6 ↑                  39: *10.2 ↓                  40: *10.2 ↙</p> <p>Serie 95.0 Total 386.0</p>

<p>Prov</p> 	<p>1: 9.7 ↘                  2: 9.4 ↘                  3: *10.2 →                  4: *10.2 ↗                  5: *10.3 ↙                  6: 10.1 →                  7: *10.7 ↘                  8: *10.2 →                  9: *10.4 ↑                  10: *10.6 →</p> <table border="1" style="width:100%; border-collapse: collapse;"> <tr><td>Serie</td><td>98.0</td></tr> <tr><td>Total</td><td>0.0</td></tr> </table>	Serie	98.0	Total	0.0	<p>Prov</p> 	<p>11: *10.2 ↗                  12: *10.3 ↗                  13: *10.4 ↑                  14: 10.1 →                  15: 10.0 ↑                  16: 10.1 ↑                  17: 9.8 ↑                  18: *10.5 →                  19: *10.3 ↙                  20: *10.6 ↘</p> <table border="1" style="width:100%; border-collapse: collapse;"> <tr><td>Serie</td><td>99.0</td></tr> <tr><td>Total</td><td>0.0</td></tr> </table>	Serie	99.0	Total	0.0
Serie	98.0										
Total	0.0										
Serie	99.0										
Total	0.0										

<p>40 Skott</p> 	<p>1: *10.7 ↘                  2: *10.9 →                  3: *10.8 →                  4: *10.8 →                  5: *10.4 ↘                  6: *10.7 ↙                  7: *10.8 →                  8: 10.1 ↘                  9: 10.1 →                  10: *10.7 ↑</p> <table border="1" style="width:100%; border-collapse: collapse;"> <tr><td>Serie</td><td>100.0</td></tr> <tr><td>Total</td><td>100.0</td></tr> </table>	Serie	100.0	Total	100.0	<p>40 Skott</p> 	<p>11: *10.4 →                  12: 10.1 ↙                  13: *10.5 ↘                  14: *10.7 ↗                  15: *10.6 ↙                  16: *10.3 ↙                  17: *10.6 ↘                  18: *10.4 ↙                  19: *10.2 ↙                  20: *10.9 ↘</p> <table border="1" style="width:100%; border-collapse: collapse;"> <tr><td>Serie</td><td>100.0</td></tr> <tr><td>Total</td><td>200.0</td></tr> </table>	Serie	100.0	Total	200.0
Serie	100.0										
Total	100.0										
Serie	100.0										
Total	200.0										

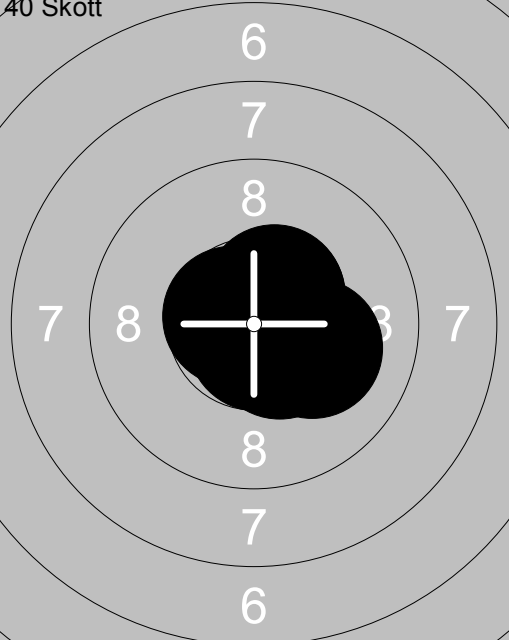
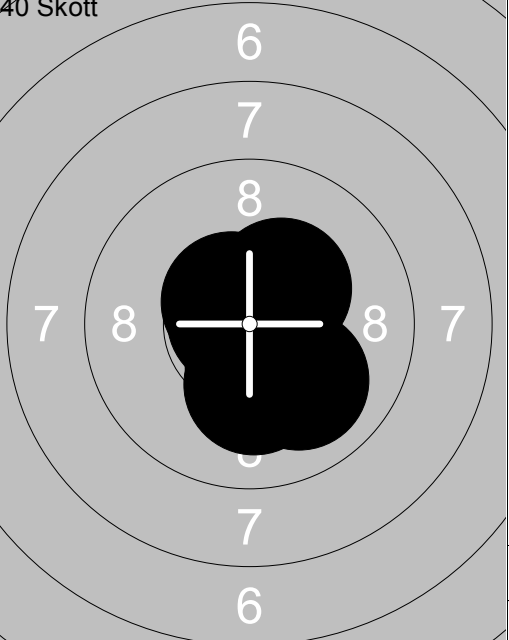
<p>40 Skott</p> 	<p>21: *10.5 ↗                  22: *10.9 ↙                  23: *10.7 ↘                  24: *10.7 →                  25: *10.7 ↘                  26: *10.9 ↘                  27: *10.5 ↗                  28: *10.5 ↘                  29: 10.1 →                  30: *10.6 →</p> <table border="1" style="width:100%; border-collapse: collapse;"> <tr><td>Serie</td><td>100.0</td></tr> <tr><td>Total</td><td>300.0</td></tr> </table>	Serie	100.0	Total	300.0	<p>40 Skott</p> 	<p>31: *10.6 ↗                  32: *10.4 ↘                  33: *10.4 ↘                  34: *10.8 ↘                  35: *10.4 ↘                  36: *10.2 ↘                  37: *10.3 ↗                  38: *10.6 ↘                  39: *10.8 ↘                  40: 10.0 ↘</p> <table border="1" style="width:100%; border-collapse: collapse;"> <tr><td>Serie</td><td>100.0</td></tr> <tr><td>Total</td><td>400.0</td></tr> </table>	Serie	100.0	Total	400.0
Serie	100.0										
Total	300.0										
Serie	100.0										
Total	400.0										

<p>Prov</p>	<p>1: 9.9 ↗                  2: 9.9 ↑                  3: *10.3 ↗                  4: 9.7 ↗                  5: 10.1 ↗                  6: 9.7 ↗                  7: *10.9 ↖                  8: *10.4 ↖                  9: *10.6 ↑                  10: *10.3 ↘</p>	<p>Prov</p>	<p>11: *10.2 ↘</p>
Serie 96.0		Serie 10.0	
Total 0.0		Total 0.0	

<p>40 Skott</p>	<p>1: *10.3 ↘                  2: 10.0 ↘                  3: 10.1 ↗                  4: *10.7 ↗                  5: *10.4 ↗                  6: *10.7 ↗                  7: *10.2 ↗                  8: *10.5 ↘                  9: *10.8 ↘                  10: *10.5 ↖</p>	<p>11: *10.6 ↗                  12: *10.2 ↖                  13: *10.5 ↖                  14: *10.6 ↗                  15: 10.1 ↘                  16: *10.2 ↖                  17: *10.2 ↗                  18: *10.6 ↘                  19: *10.3 ↗                  20: *10.6 ↘</p>	
Serie 100.0		Serie 100.0	
Total 100.0		Total 200.0	

<p>40 Skott</p>	<p>21: 10.1 ↘                  22: *10.6 ↘                  23: *10.3 ↖                  24: 10.0 ↖                  25: *10.4 ↘                  26: 10.1 ↗                  27: *10.6 ↘                  28: *10.7 ↘                  29: *10.6 ↘                  30: *10.7 ↑</p>	<p>31: *10.7 ↘                  32: *10.8 ↖                  33: *10.3 ↗                  34: *10.4 ↘                  35: *10.8 ↗                  36: 10.1 ↘                  37: *10.3 ↖                  38: *10.4 ↖                  39: *10.3 ↖                  40: *10.8 ↘</p>	
Serie 100.0		Serie 100.0	
Total 300.0		Total 400.0	

<p>Prov</p>	<p>1: 9.5 →</p> <p>2: *10.4 ↓</p> <p>3: *10.5 →</p> <p>4: 9.8 ↗</p> <p>5: *10.2 →</p> <p>6: *10.3 ↓</p> <p>7: *10.2 ↘</p> <p>8: *10.5 ↓</p> <p>9: 9.8 ↖</p> <p>10: *10.6 ↘</p> <hr/> <p>Serie 97.0</p> <p>Total 0.0</p>	<p>Prov</p>	<p>11: *10.3 ↑</p> <p>12: *10.6 ↖</p> <p>13: *10.7 →</p> <hr/> <p>Serie 30.0</p> <p>Total 0.0</p>
<p>40 Skott</p>	<p>1: 10.0 ↖</p> <p>2: 10.1 ↓</p> <p>3: 9.9 ↗</p> <p>4: *10.3 ↘</p> <p>5: *10.3 ↑</p> <p>6: *10.6 ↘</p> <p>7: *10.5 ↑</p> <p>8: *10.4 ↑</p> <p>9: *10.8 →</p> <p>10: *10.5 →</p> <hr/> <p>Serie 99.0</p> <p>Total 99.0</p>	<p>40 Skott</p>	<p>11: *10.2 ↖</p> <p>12: *10.8 ↓</p> <p>13: *10.5 ↓</p> <p>14: *10.2 ↖</p> <p>15: *10.4 ↑</p> <p>16: *10.5 ↘</p> <p>17: *10.3 ↗</p> <p>18: *10.5 ↖</p> <p>19: *10.7 ↖</p> <p>20: *10.4 ↑</p> <hr/> <p>Serie 100.0</p> <p>Total 199.0</p>
<p>40 Skott</p>	<p>21: *10.3 ↖</p> <p>22: *10.2 ↖</p> <p>23: *10.4 ↖</p> <p>24: *10.2 ↖</p> <p>25: *10.4 ↖</p> <p>26: *10.7 ↖</p> <p>27: *10.5 ↑</p> <p>28: 9.8 →</p> <p>29: *10.5 ↓</p> <p>30: *10.7 ↑</p> <hr/> <p>Serie 99.0</p> <p>Total 298.0</p>	<p>40 Skott</p>	<p>31: *10.2 ↑</p> <p>32: *10.8 ↖</p> <p>33: *10.9 →</p> <p>34: 9.9 ↗</p> <p>35: *10.4 ↑</p> <p>36: *10.6 ↑</p> <p>37: *10.8 ↖</p> <p>38: *10.3 ↑</p> <p>39: *10.3 ↑</p> <p>40: *10.4 ↗</p> <hr/> <p>Serie 99.0</p> <p>Total 397.0</p>



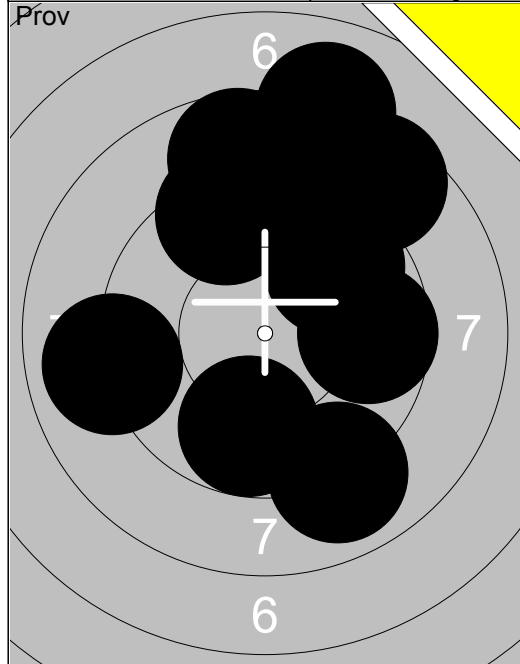

1:	8.7	↑
2:	8.8	↑
3:	9.7	↗
4:	9.6	→
5:	8.0	↑
6:	8.6	↗
7:	8.9	↓
8:	9.0	←
9:	9.7	↓
10:	9.4	↑
Serie		85.0
Total		0.0

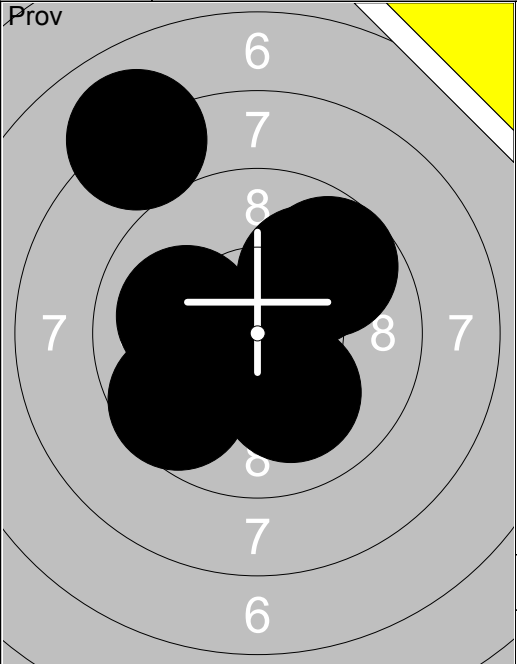

11:	9.6	↙
12:	10.1	↘
13:	9.7	↗
14:	8.0	↖
15:	10.0	↙
16:	10.0	↗
Serie		56.0
Total		0.0

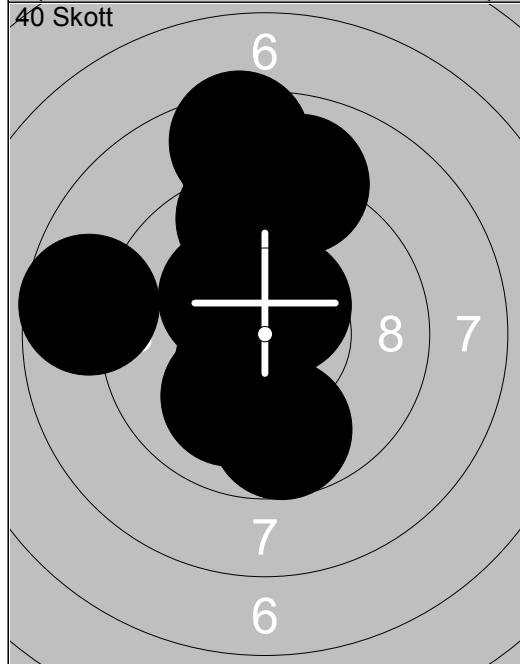

1:	*10.3	↘
2:	9.7	↓
3:	*10.5	↗
4:	9.5	↑
5:	8.7	←
6:	8.8	↑
7:	9.0	↑
8:	8.5	↑
9:	*10.5	↘
10:	10.0	↘
Serie		91.0
Total		91.0

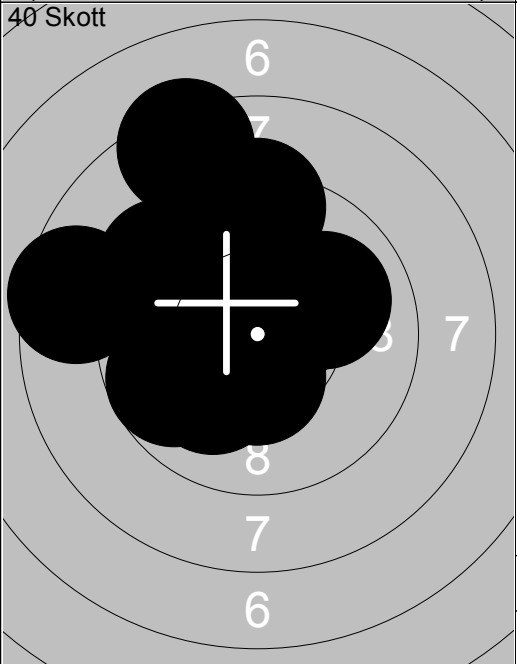

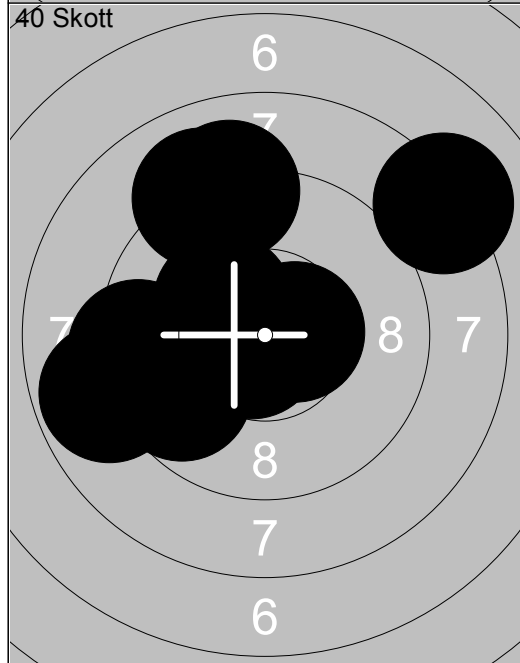

11:	10.0	↗
12:	8.3	↖
13:	10.0	↑
14:	*10.5	↗
15:	8.5	←
16:	*10.4	↘
17:	9.3	↑
18:	9.5	↖
19:	10.1	↘
20:	9.7	↙
Serie		93.0
Total		184.0

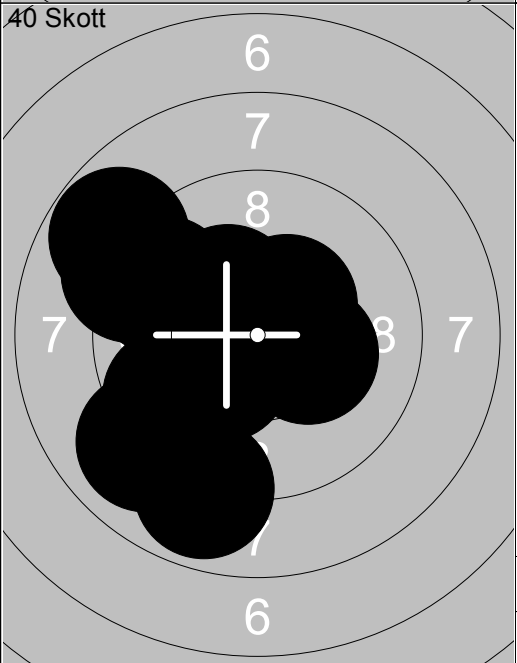

21:	*10.3	↘
22:	8.8	←
23:	*10.6	→
24:	8.1	↗
25:	9.0	↑
26:	9.3	←
27:	*10.7	↘
28:	9.7	↙
29:	9.1	↑
30:	*10.7	↖
Serie		92.0
Total		276.0

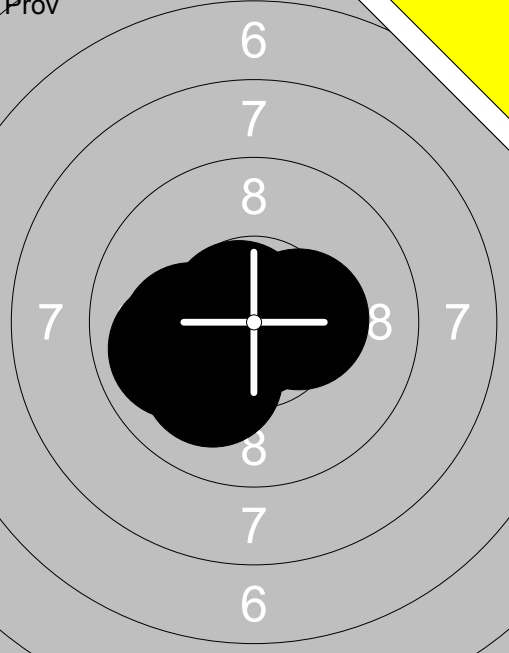
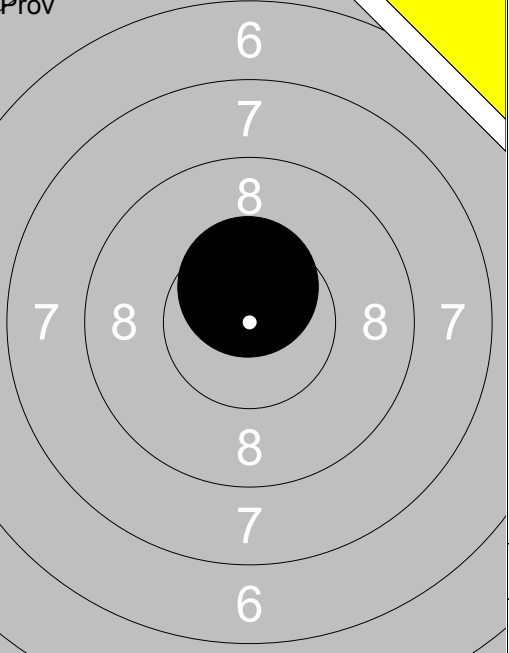
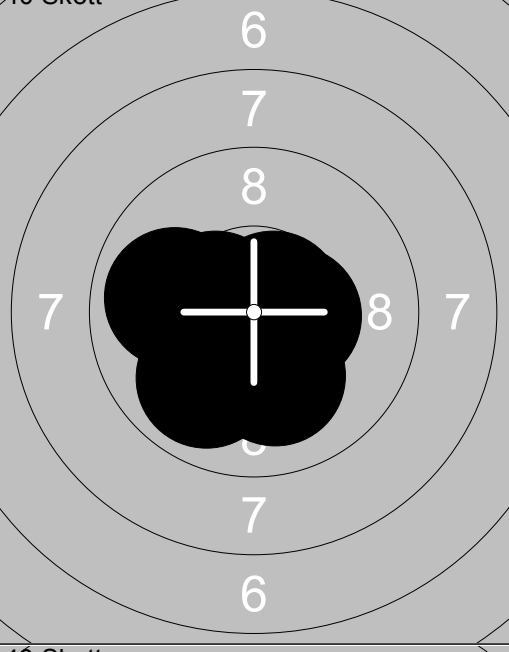
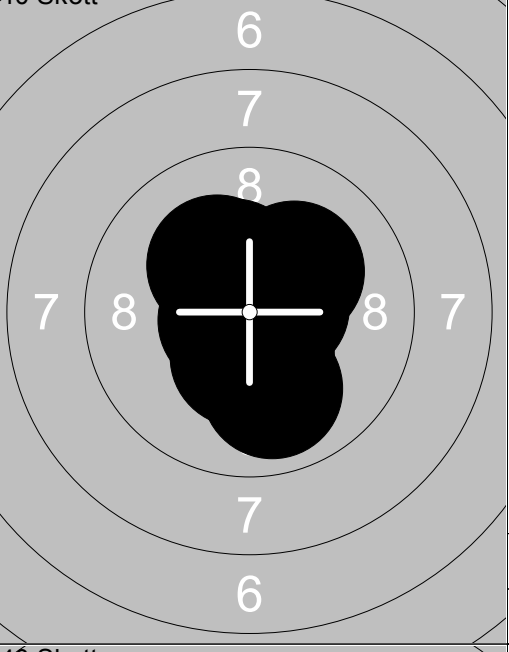

31:	*10.3	↘
32:	9.1	↖
33:	*10.3	→
34:	*10.4	↗
35:	8.8	↖
36:	9.0	↙
37:	9.6	↖
38:	9.6	↙
39:	8.9	↘
40:	*10.3	↘
Serie		92.0
Total		368.0

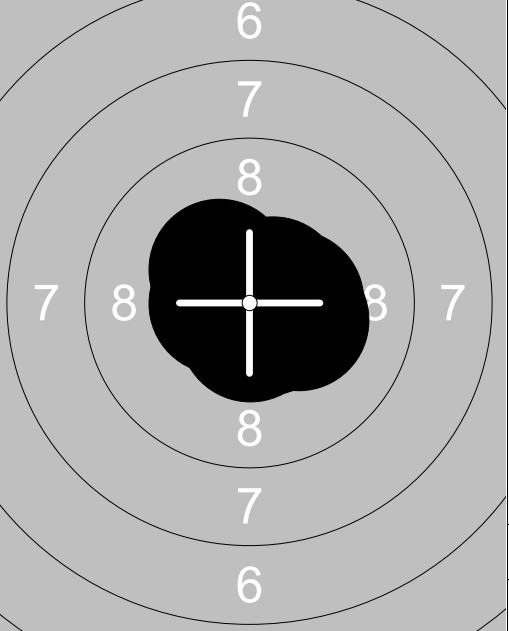
<p>Prov</p> 	<p>1: *10.9↓                  2: *10.9↓                  3: *10.7↘                  4: *10.7↘                  5: 9.9 ←                  6: *10.4↘                  7: *10.9↘                  8: 10.1 ↓                  9: *10.4→                  10: 10.1←</p> <table border="1" style="width:100%; border-collapse: collapse;"> <tr><td>Serie</td><td style="text-align:right;">99.0</td></tr> <tr><td>Total</td><td style="text-align:right;">0.0</td></tr> </table>	Serie	99.0	Total	0.0	<p>Prov</p>  <p>11: *10.5↑</p> <table border="1" style="width:100%; border-collapse: collapse;"> <tr><td>Serie</td><td style="text-align:right;">10.0</td></tr> <tr><td>Total</td><td style="text-align:right;">0.0</td></tr> </table>	Serie	10.0	Total	0.0
Serie	99.0									
Total	0.0									
Serie	10.0									
Total	0.0									
<p>40 Skott</p> 	<p>1: *10.6→                  2: *10.6↓                  3: *10.7↓                  4: 9.9 ↘                  5: *10.5→                  6: *10.5↓                  7: *10.4←                  8: 10.1 ↓                  9: *10.7↗                  10: 9.9 ←</p> <table border="1" style="width:100%; border-collapse: collapse;"> <tr><td>Serie</td><td style="text-align:right;">98.0</td></tr> <tr><td>Total</td><td style="text-align:right;">98.0</td></tr> </table>	Serie	98.0	Total	98.0	<p>40 Skott</p>  <p>11: *10.7↗                  12: *10.4↓                  13: *10.4↓                  14: 9.9 ↓                  15: *10.6→                  16: *10.4↖                  17: *10.7→                  18: *10.2↖                  19: *10.2↗                  20: *10.7↖</p> <table border="1" style="width:100%; border-collapse: collapse;"> <tr><td>Serie</td><td style="text-align:right;">99.0</td></tr> <tr><td>Total</td><td style="text-align:right;">197.0</td></tr> </table>	Serie	99.0	Total	197.0
Serie	98.0									
Total	98.0									
Serie	99.0									
Total	197.0									
<p>40 Skott</p> 	<p>21: *10.4↓                  22: *10.8→                  23: *10.4←                  24: *10.2↖                  25: *10.5↖                  26: *10.8↖                  27: *10.4↘                  28: *10.7↖                  29: 10.0←                  30: 9.9 ↑</p> <table border="1" style="width:100%; border-collapse: collapse;"> <tr><td>Serie</td><td style="text-align:right;">99.0</td></tr> <tr><td>Total</td><td style="text-align:right;">296.0</td></tr> </table>	Serie	99.0	Total	296.0	<p>40 Skott</p>  <p>31: *10.4→                  32: *10.3→                  33: *10.4↖                  34: *10.6↓                  35: *10.7↘                  36: *10.6←                  37: *10.6↗                  38: *10.5→                  39: *10.8↘                  40: *10.6↓</p> <table border="1" style="width:100%; border-collapse: collapse;"> <tr><td>Serie</td><td style="text-align:right;">100.0</td></tr> <tr><td>Total</td><td style="text-align:right;">396.0</td></tr> </table>	Serie	100.0	Total	396.0
Serie	99.0									
Total	296.0									
Serie	100.0									
Total	396.0									

<p>Prov</p>	<p>1: *10.2 ↘                  2: 9.9 →                  3: *10.7 →                  4: *10.2 ↘                  5: 9.8 ←                  6: *10.6 ↘                  7: *10.7 ↓                  8: 9.5 ↓                  9: *10.5 ↘                  10: *10.7 ↘</p>	<p>Prov</p>	<p>11: *10.4 ↓                  12: *10.4 ↓                  13: 10.1 ←</p>
Serie 97.0		Serie 30.0	
Total 0.0		Total 0.0	

<p>40 Skott</p>	<p>1: 9.9 ↖                  2: *10.5 ↑                  3: 9.6 ←                  4: *10.3 ↘                  5: 9.6 ←                  6: *10.3 ↓                  7: 10.0 ↑                  8: *10.2 →                  9: *10.7 ←                  10: *10.3 →</p>	<p>40 Skott</p>	<p>11: *10.5 ↑                  12: 10.0 ←                  13: *10.7 →                  14: *10.3 →                  15: *10.6 ↘                  16: *10.7 →                  17: *10.6 ↓                  18: *10.8 ↗                  19: 10.0 →                  20: *10.4 ↗</p>
Serie 97.0		Serie 100.0	
Total 97.0		Total 197.0	

<p>40 Skott</p>	<p>21: *10.6 ↘                  22: 10.1 ↓                  23: *10.3 ↓                  24: *10.5 ↘                  25: *10.4 ↘                  26: 10.1 ↓                  27: *10.8 ↘                  28: *10.2 ↘                  29: *10.7 ↘                  30: *10.7 ↘</p>	<p>40 Skott</p>	<p>31: *10.8 ↘                  32: *10.4 ↘                  33: *10.3 ↑                  34: 10.1 →                  35: 10.0 ↓                  36: *10.7 ↓                  37: 10.1 ↓                  38: *10.7 ↓                  39: 9.8 ↓                  40: 9.6 ↑</p>
Serie 100.0		Serie 98.0	
Total 297.0		Total 395.0	

<p>Prov</p>	<p>1: 9.9 ↓                  2: *10.7 ↓                  3: *10.5 ↓                  4: *10.5 ↓                  5: *10.3 ↓                  6: 10.1 ↓                  7: 9.7 ↓                  8: *10.4 ↖                  9: *10.2 ←                  10: *10.6 ↖</p> <table border="1" style="width:100%; border-collapse: collapse;"> <tr> <td style="text-align: right;">Serie</td> <td style="text-align: right;">98.0</td> </tr> <tr> <td style="text-align: right;">Total</td> <td style="text-align: right;">0.0</td> </tr> </table>	Serie	98.0	Total	0.0	<p>Prov</p>	<p>11: *10.5 ↗                  12: *10.8 ↘                  13: *10.7 ↖                  14: *10.7 ↖                  15: *10.2 ↗</p> <table border="1" style="width:100%; border-collapse: collapse;"> <tr> <td style="text-align: right;">Serie</td> <td style="text-align: right;">50.0</td> </tr> <tr> <td style="text-align: right;">Total</td> <td style="text-align: right;">0.0</td> </tr> </table>	Serie	50.0	Total	0.0
Serie	98.0										
Total	0.0										
Serie	50.0										
Total	0.0										
<p>40 Skott</p>	<p>1: *10.8 →                  2: *10.2 ↖                  3: *10.3 ↑                  4: 10.0 ↖                  5: *10.3 ↗                  6: *10.5 ↘                  7: *10.6 →                  8: *10.6 ↖                  9: *10.6 ↖                  10: *10.7 ↑</p> <table border="1" style="width:100%; border-collapse: collapse;"> <tr> <td style="text-align: right;">Serie</td> <td style="text-align: right;">100.0</td> </tr> <tr> <td style="text-align: right;">Total</td> <td style="text-align: right;">100.0</td> </tr> </table>	Serie	100.0	Total	100.0	<p>40 Skott</p>	<p>11: *10.5 ↘                  12: *10.8 →                  13: *10.7 ←                  14: 10.0 ↑                  15: *10.6 ↘                  16: *10.4 ↓                  17: *10.2 ↖                  18: *10.5 ↖                  19: *10.5 ↘                  20: *10.8 ↓</p> <table border="1" style="width:100%; border-collapse: collapse;"> <tr> <td style="text-align: right;">Serie</td> <td style="text-align: right;">100.0</td> </tr> <tr> <td style="text-align: right;">Total</td> <td style="text-align: right;">200.0</td> </tr> </table>	Serie	100.0	Total	200.0
Serie	100.0										
Total	100.0										
Serie	100.0										
Total	200.0										
<p>40 Skott</p>	<p>21: 9.7 ←                  22: 10.1 ←                  23: *10.8 ←                  24: *10.5 ↖                  25: *10.4 ↓                  26: *10.8 ↑                  27: *10.5 ↖                  28: 9.6 ←                  29: *10.4 ↓                  30: *10.2 ↓</p> <table border="1" style="width:100%; border-collapse: collapse;"> <tr> <td style="text-align: right;">Serie</td> <td style="text-align: right;">98.0</td> </tr> <tr> <td style="text-align: right;">Total</td> <td style="text-align: right;">298.0</td> </tr> </table>	Serie	98.0	Total	298.0	<p>40 Skott</p>	<p>31: *10.6 ↖                  32: *10.8 ↓                  33: *10.6 ↓                  34: *10.5 ↘                  35: *10.2 ↖                  36: *10.3 ↓                  37: 10.1 ↓                  38: *10.4 ↖                  39: *10.4 →                  40: *10.7 ↘</p> <table border="1" style="width:100%; border-collapse: collapse;"> <tr> <td style="text-align: right;">Serie</td> <td style="text-align: right;">100.0</td> </tr> <tr> <td style="text-align: right;">Total</td> <td style="text-align: right;">398.0</td> </tr> </table>	Serie	100.0	Total	398.0
Serie	98.0										
Total	298.0										
Serie	100.0										
Total	398.0										

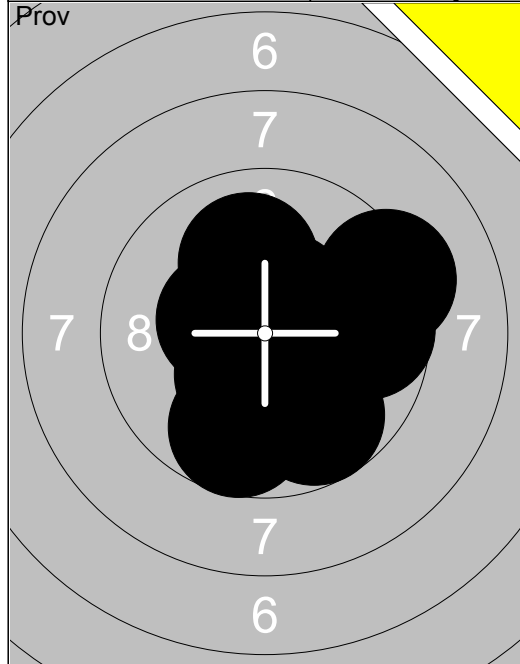

1:	*10.4↙
2:	*10.7↑
3:	9.7 →
4:	10.0 ↑
5:	*10.4↘
6:	*10.5↑
7:	9.3 →
8:	9.7 ↓
9:	*10.2↓
10:	9.7 ↓
Serie 96.0	
Total 0.0	

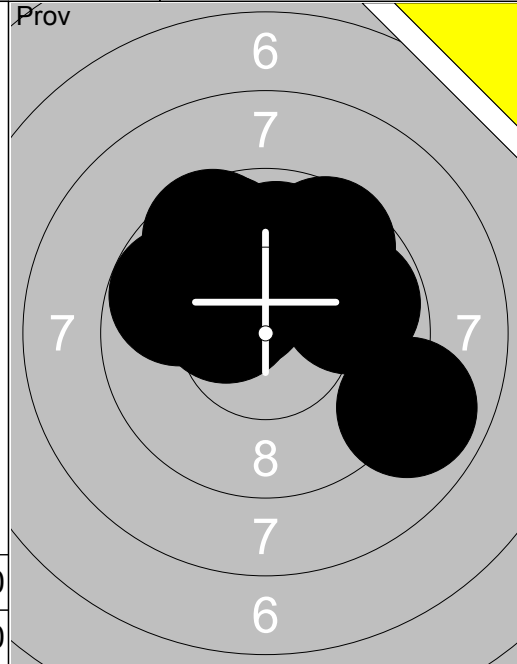

11:	9.6 ↗
12:	*10.4↙
13:	9.7 ↙
14:	*10.4↙
15:	9.8 →
16:	9.6 ↗
17:	9.9 ↑
18:	8.9 →
19:	9.7 ↗
Serie 82.0	
Total 0.0	

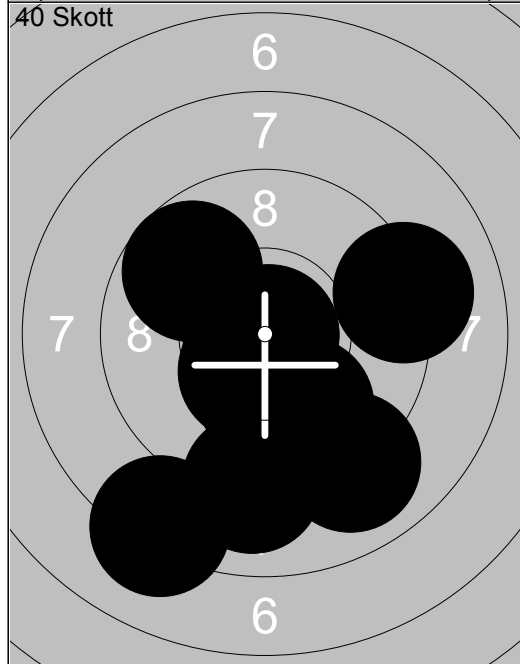

1:	*10.7↘
2:	9.9 ↓
3:	9.0 ↓
4:	*10.9→
5:	9.7 ↗
6:	*10.2↓
7:	*10.4↘
8:	8.2 ↓
9:	9.0 ↓
10:	9.1 →
Serie 93.0	
Total 93.0	

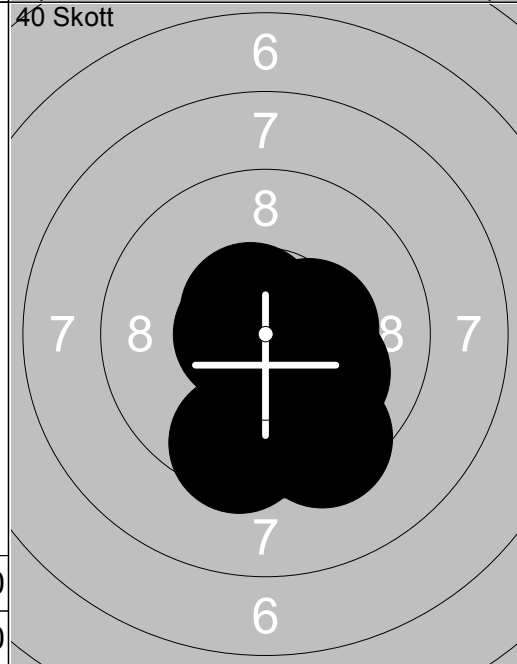

11:	10.1 ↘
12:	*10.6↙
13:	9.5 ↓
14:	10.1 ↓
15:	9.4 ↓
16:	*10.4→
17:	*10.8↙
18:	10.0 ↓
19:	9.7 ↓
20:	*10.7↙
Serie 97.0	
Total 190.0	

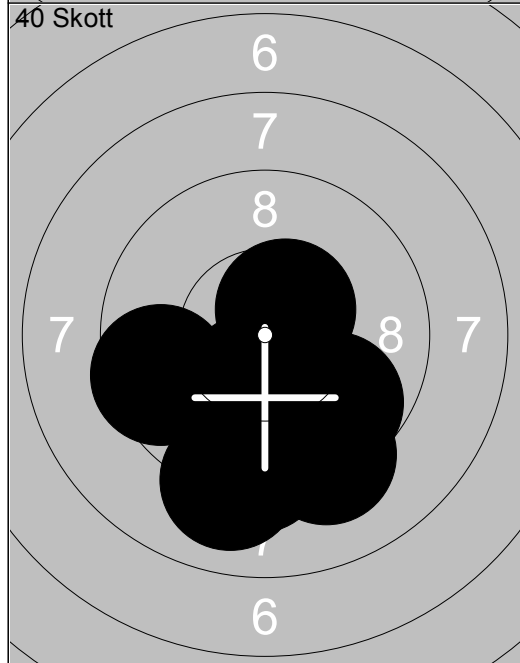

21:	9.4 ↓
22:	9.0 ↓
23:	*10.3↓
24:	9.7 ↘
25:	9.6 ↓
26:	*10.5↑
27:	9.2 ↓
28:	9.7 ↓
29:	9.3 ↓
30:	9.5 ↙
Serie 92.0	
Total 282.0	

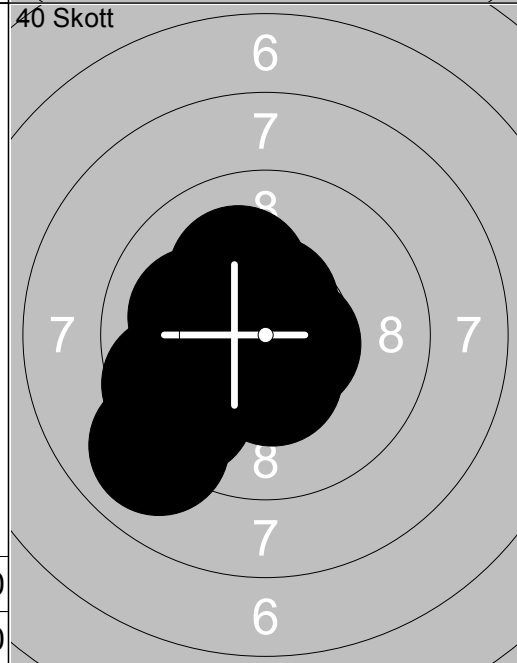

31:	*10.6→
32:	10.1 ↙
33:	*10.4↓
34:	9.0 ↘
35:	9.6 ↘
36:	*10.6↑
37:	9.6 ↙
38:	10.1 ↗
39:	*10.2↙
40:	*10.3↙
Serie 97.0	
Total 379.0	

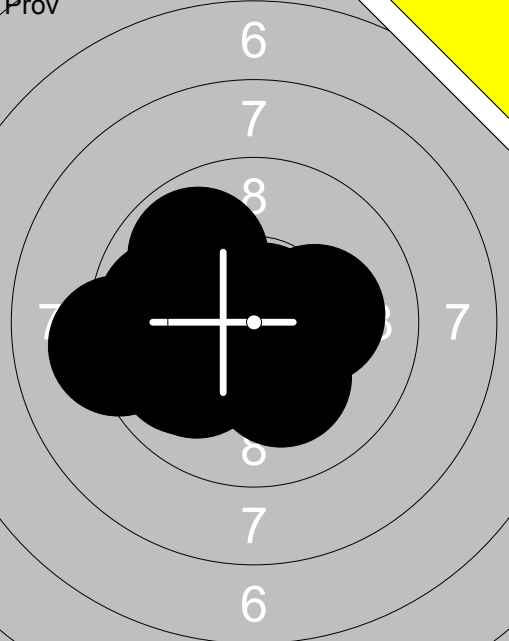
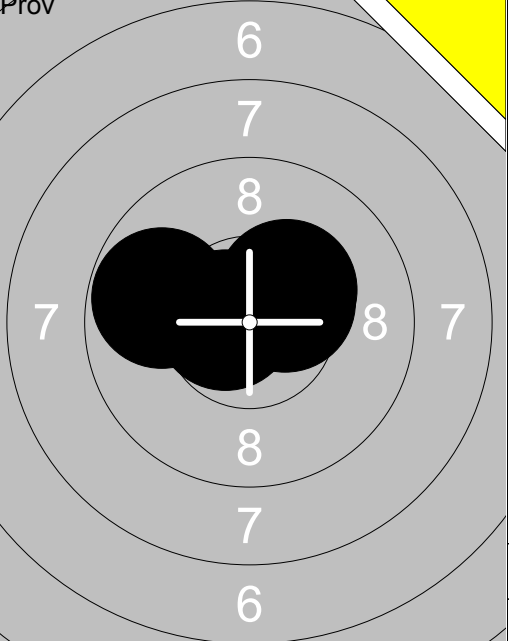
Prov 	1: 9.9 ↙ 2: 9.2 ← 3: 10.0 ← 4: 9.9 ↗ 5: 9.8 ← 6: *10.4 ↘ 7: *10.8 ↗ 8: *10.2 ↘ 9: 10.0 ↙ 10: *10.2 →	Prov 	11: *10.3 ↗ 12: *10.4 ↗ 13: 9.8 ← 14: *10.6 ↙
Serie	96.0	Serie	39.0
Total	0.0	Total	0.0

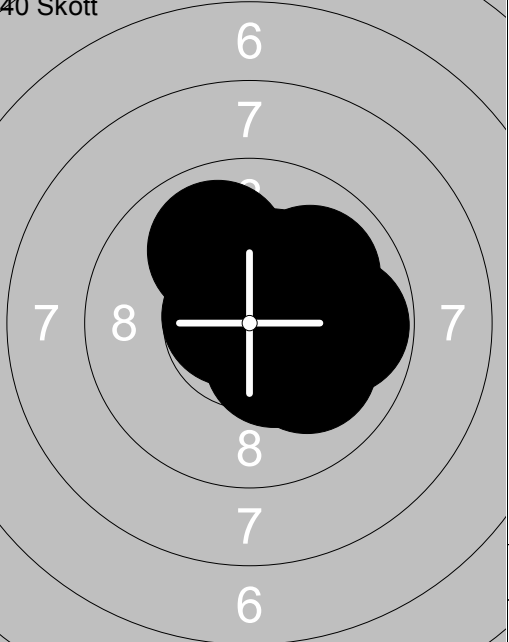
40 Skott 	1: 9.7 ↓ 2: 9.6 → 3: 9.6 ↗ 4: *10.3 ↗ 5: 9.7 ↗ 6: 9.8 ↑ 7: *10.4 ↘ 8: 9.8 → 9: *10.9 ↘ 10: *10.4 ↘	40 Skott 	11: 10.0 ↗ 12: *10.6 ↘ 13: *10.4 ↘ 14: 9.9 ↗ 15: 10.1 → 16: 9.8 → 17: *10.3 ↗ 18: 10.1 ↗ 19: 10.1 ↘ 20: *10.7 ↘
Serie	94.0	Serie	98.0
Total	94.0	Total	192.0

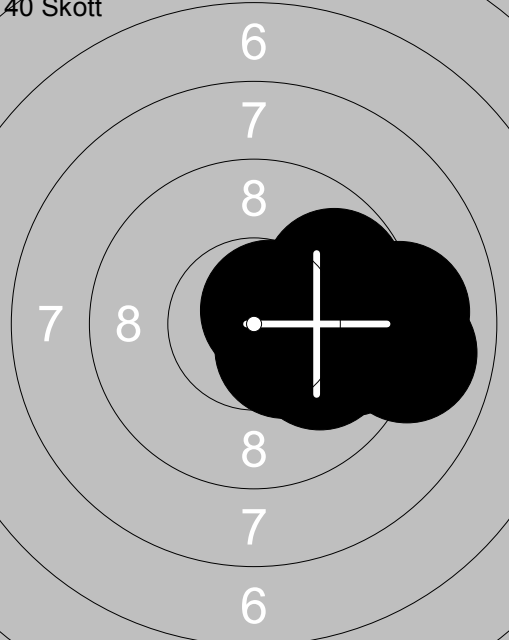
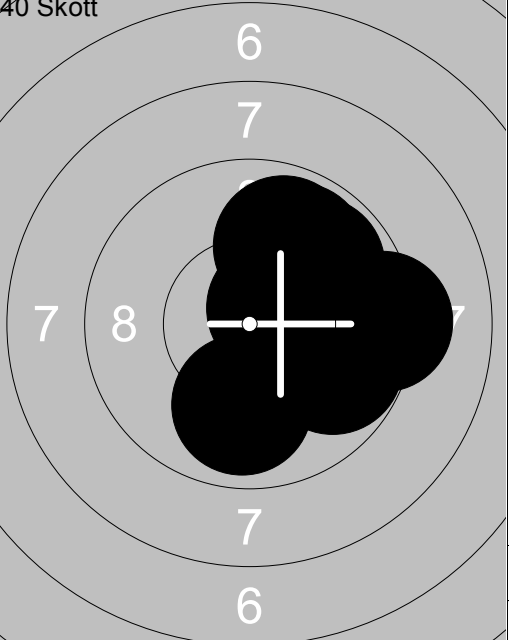
40 Skott 	21: *10.7 ↗ 22: *10.4 ↘ 23: 9.8 ↗ 24: 9.7 → 25: *10.2 → 26: 10.0 ↘ 27: 9.1 → 28: 9.0 → 29: 9.6 → 30: *10.3 →	40 Skott 	31: *10.2 ↗ 32: 9.3 → 33: 9.9 ↗ 34: 9.8 ↗ 35: 9.9 ↗ 36: *10.6 ↗ 37: 9.9 ↓ 38: *10.3 → 39: 9.9 → 40: 9.8 →
Serie	95.0	Serie	93.0
Total	287.0	Total	380.0

<p>Pröv</p>	<table border="1" style="width:100%; border-collapse: collapse;"> <tr><td>1:</td><td>8.9</td><td>↗</td></tr> <tr><td>2:</td><td>9.1</td><td>↑</td></tr> <tr><td>3:</td><td>10.1</td><td>↗</td></tr> <tr><td>4:</td><td>8.5</td><td>↑</td></tr> <tr><td>5:</td><td>*10.3</td><td>↑</td></tr> <tr><td>6:</td><td>9.7</td><td>↑</td></tr> <tr><td>7:</td><td>*10.4</td><td>→</td></tr> <tr><td>8:</td><td>*10.4</td><td>↖</td></tr> <tr><td>9:</td><td>*10.7</td><td>↗</td></tr> <tr><td>10:</td><td>*10.5</td><td>↖</td></tr> <tr><td colspan="2">Serie</td><td>94.0</td></tr> <tr><td colspan="2">Total</td><td>0.0</td></tr> </table>	1:	8.9	↗	2:	9.1	↑	3:	10.1	↗	4:	8.5	↑	5:	*10.3	↑	6:	9.7	↑	7:	*10.4	→	8:	*10.4	↖	9:	*10.7	↗	10:	*10.5	↖	Serie		94.0	Total		0.0	<p>Pröv</p>	<table border="1" style="width:100%; border-collapse: collapse;"> <tr><td>11:</td><td>*10.3</td><td>↓</td></tr> <tr><td>12:</td><td>9.9</td><td>↓</td></tr> <tr><td>13:</td><td>*10.3</td><td>↖</td></tr> <tr><td>14:</td><td>*10.3</td><td>→</td></tr> <tr><td>15:</td><td>10.1</td><td>↗</td></tr> <tr><td>17:</td><td>10.1</td><td>↓</td></tr> <tr><td>18:</td><td>9.7</td><td>↑</td></tr> <tr><td>19:</td><td>9.5</td><td>↑</td></tr> <tr><td>20:</td><td>*10.3</td><td>→</td></tr> <tr><td colspan="2">Serie</td><td>87.0</td></tr> <tr><td colspan="2">Total</td><td>0.0</td></tr> </table>	11:	*10.3	↓	12:	9.9	↓	13:	*10.3	↖	14:	*10.3	→	15:	10.1	↗	17:	10.1	↓	18:	9.7	↑	19:	9.5	↑	20:	*10.3	→	Serie		87.0	Total		0.0
1:	8.9	↗																																																																						
2:	9.1	↑																																																																						
3:	10.1	↗																																																																						
4:	8.5	↑																																																																						
5:	*10.3	↑																																																																						
6:	9.7	↑																																																																						
7:	*10.4	→																																																																						
8:	*10.4	↖																																																																						
9:	*10.7	↗																																																																						
10:	*10.5	↖																																																																						
Serie		94.0																																																																						
Total		0.0																																																																						
11:	*10.3	↓																																																																						
12:	9.9	↓																																																																						
13:	*10.3	↖																																																																						
14:	*10.3	→																																																																						
15:	10.1	↗																																																																						
17:	10.1	↓																																																																						
18:	9.7	↑																																																																						
19:	9.5	↑																																																																						
20:	*10.3	→																																																																						
Serie		87.0																																																																						
Total		0.0																																																																						

<p>Pröv</p>	<table border="1" style="width:100%; border-collapse: collapse;"> <tr><td>21:</td><td>*10.5</td><td>↑</td></tr> <tr><td colspan="2">Serie</td><td>10.0</td></tr> <tr><td colspan="2">Total</td><td>0.0</td></tr> </table>	21:	*10.5	↑	Serie		10.0	Total		0.0	<p>40 Skott</p>	<table border="1" style="width:100%; border-collapse: collapse;"> <tr><td>1:</td><td>*10.4</td><td>→</td></tr> <tr><td>2:</td><td>*10.2</td><td>↑</td></tr> <tr><td>3:</td><td>*10.2</td><td>↑</td></tr> <tr><td>4:</td><td>9.4</td><td>↑</td></tr> <tr><td>5:</td><td>*10.4</td><td>↗</td></tr> <tr><td>6:</td><td>9.5</td><td>↖</td></tr> <tr><td>7:</td><td>*10.6</td><td>→</td></tr> <tr><td>8:</td><td>*10.3</td><td>↗</td></tr> <tr><td>9:</td><td>*10.7</td><td>↑</td></tr> <tr><td>10:</td><td>9.8</td><td>→</td></tr> <tr><td colspan="2">Serie</td><td>97.0</td></tr> <tr><td colspan="2">Total</td><td>97.0</td></tr> </table>	1:	*10.4	→	2:	*10.2	↑	3:	*10.2	↑	4:	9.4	↑	5:	*10.4	↗	6:	9.5	↖	7:	*10.6	→	8:	*10.3	↗	9:	*10.7	↑	10:	9.8	→	Serie		97.0	Total		97.0
21:	*10.5	↑																																														
Serie		10.0																																														
Total		0.0																																														
1:	*10.4	→																																														
2:	*10.2	↑																																														
3:	*10.2	↑																																														
4:	9.4	↑																																														
5:	*10.4	↗																																														
6:	9.5	↖																																														
7:	*10.6	→																																														
8:	*10.3	↗																																														
9:	*10.7	↑																																														
10:	9.8	→																																														
Serie		97.0																																														
Total		97.0																																														

<p>40 Skott</p>	<table border="1" style="width:100%; border-collapse: collapse;"> <tr><td>11:</td><td>9.9</td><td>↖</td></tr> <tr><td>12:</td><td>*10.4</td><td>↗</td></tr> <tr><td>13:</td><td>*10.5</td><td>↑</td></tr> <tr><td>14:</td><td>10.1</td><td>↗</td></tr> <tr><td>15:</td><td>*10.5</td><td>↖</td></tr> <tr><td>16:</td><td>*10.6</td><td>↗</td></tr> <tr><td>17:</td><td>*10.2</td><td>↓</td></tr> <tr><td>18:</td><td>*10.8</td><td>↖</td></tr> <tr><td>19:</td><td>10.0</td><td>→</td></tr> <tr><td>20:</td><td>*10.7</td><td>↑</td></tr> <tr><td colspan="2">Serie</td><td>99.0</td></tr> <tr><td colspan="2">Total</td><td>196.0</td></tr> </table>	11:	9.9	↖	12:	*10.4	↗	13:	*10.5	↑	14:	10.1	↗	15:	*10.5	↖	16:	*10.6	↗	17:	*10.2	↓	18:	*10.8	↖	19:	10.0	→	20:	*10.7	↑	Serie		99.0	Total		196.0	<p>40 Skott</p>	<table border="1" style="width:100%; border-collapse: collapse;"> <tr><td>21:</td><td>*10.4</td><td>↖</td></tr> <tr><td>22:</td><td>*10.8</td><td>↓</td></tr> <tr><td>23:</td><td>*10.6</td><td>↑</td></tr> <tr><td>24:</td><td>*10.5</td><td>→</td></tr> <tr><td>25:</td><td>*10.2</td><td>↑</td></tr> <tr><td>26:</td><td>*10.2</td><td>↗</td></tr> <tr><td>27:</td><td>*10.6</td><td>→</td></tr> <tr><td>28:</td><td>9.6</td><td>↓</td></tr> <tr><td>29:</td><td>*10.2</td><td>↑</td></tr> <tr><td>30:</td><td>*10.4</td><td>↗</td></tr> <tr><td colspan="2">Serie</td><td>99.0</td></tr> <tr><td colspan="2">Total</td><td>295.0</td></tr> </table>	21:	*10.4	↖	22:	*10.8	↓	23:	*10.6	↑	24:	*10.5	→	25:	*10.2	↑	26:	*10.2	↗	27:	*10.6	→	28:	9.6	↓	29:	*10.2	↑	30:	*10.4	↗	Serie		99.0	Total		295.0
11:	9.9	↖																																																																									
12:	*10.4	↗																																																																									
13:	*10.5	↑																																																																									
14:	10.1	↗																																																																									
15:	*10.5	↖																																																																									
16:	*10.6	↗																																																																									
17:	*10.2	↓																																																																									
18:	*10.8	↖																																																																									
19:	10.0	→																																																																									
20:	*10.7	↑																																																																									
Serie		99.0																																																																									
Total		196.0																																																																									
21:	*10.4	↖																																																																									
22:	*10.8	↓																																																																									
23:	*10.6	↑																																																																									
24:	*10.5	→																																																																									
25:	*10.2	↑																																																																									
26:	*10.2	↗																																																																									
27:	*10.6	→																																																																									
28:	9.6	↓																																																																									
29:	*10.2	↑																																																																									
30:	*10.4	↗																																																																									
Serie		99.0																																																																									
Total		295.0																																																																									

<p>40 Skott</p>	<table border="1" style="width:100%; border-collapse: collapse;"> <tr><td>31:</td><td>*10.2</td><td>↓</td></tr> <tr><td>32:</td><td>9.8</td><td>→</td></tr> <tr><td>33:</td><td>9.8</td><td>↑</td></tr> <tr><td>34:</td><td>*10.3</td><td>↗</td></tr> <tr><td>35:</td><td>10.1</td><td>→</td></tr> <tr><td>36:</td><td>9.6</td><td>↑</td></tr> <tr><td>37:</td><td>9.6</td><td>↑</td></tr> <tr><td>38:</td><td>9.9</td><td>↑</td></tr> <tr><td>39:</td><td>9.7</td><td>↗</td></tr> <tr><td>40:</td><td>9.5</td><td>↑</td></tr> <tr><td colspan="2">Serie</td><td>93.0</td></tr> <tr><td colspan="2">Total</td><td>388.0</td></tr> </table>	31:	*10.2	↓	32:	9.8	→	33:	9.8	↑	34:	*10.3	↗	35:	10.1	→	36:	9.6	↑	37:	9.6	↑	38:	9.9	↑	39:	9.7	↗	40:	9.5	↑	Serie		93.0	Total		388.0		
31:	*10.2	↓																																					
32:	9.8	→																																					
33:	9.8	↑																																					
34:	*10.3	↗																																					
35:	10.1	→																																					
36:	9.6	↑																																					
37:	9.6	↑																																					
38:	9.9	↑																																					
39:	9.7	↗																																					
40:	9.5	↑																																					
Serie		93.0																																					
Total		388.0																																					

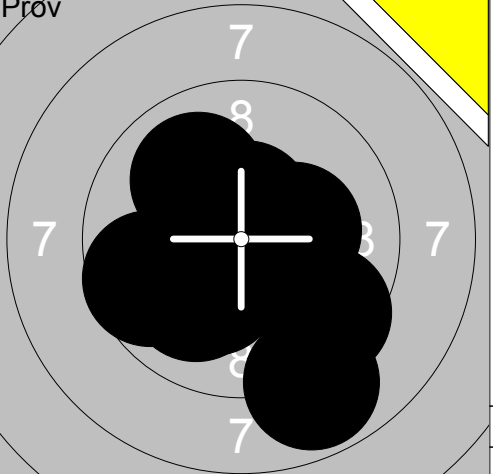

<b>Pröv</b> 	1: 8.5 → 2: *10.4 ↓ 3: 9.7 ↗ 4: *10.4 ↘ 5: *10.8 ↓ 6: 9.7 → 7: 9.9 ↗ 8: 8.7 ↗ 9: 9.9 ↗ 10: 9.8 ↗	<b>Pröv</b> 		11: 9.5 ↘ 12: *10.9 ↗ 13: 10.0 ↗ 14: *10.3 → 15: 10.0 ↘ 16: 9.6 ← 17: *10.2 ↓ 18: 8.8 ↓ 19: *10.5 ↗ 20: *10.6 ↗
	Serie 91.0			Serie 96.0
	Total 0.0			Total 0.0

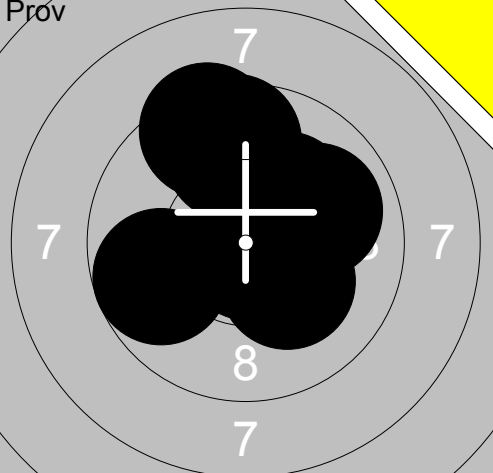
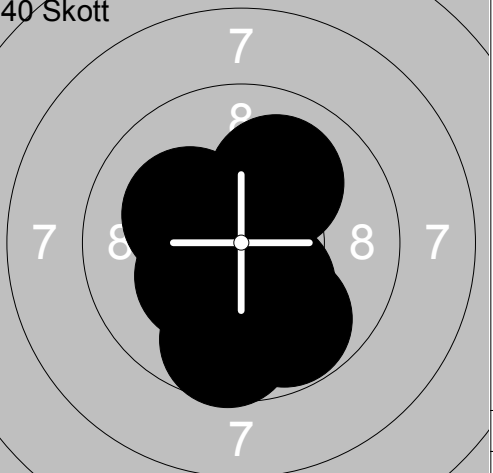
<b>Pröv</b> 	21: 9.7 ← 22: *10.8 ↓ 23: 9.8 ↗ 24: 9.6 ↗ 25: 10.0 → 26: 9.4 ↗ 27: *10.6 → 28: *10.2 ↗ 29: *10.2 ↘	<b>40 Skott</b> 		1: 9.7 ↓ 2: *10.3 ↘ 3: *10.2 ↗ 4: *10.9 ← 5: *10.5 ↗ 6: 10.0 ↗ 7: *10.4 ↘ 8: *10.2 ↓ 9: *10.3 ↓ 10: 9.8 ↓
	Serie 86.0			Serie 98.0
	Total 0.0			Total 98.0

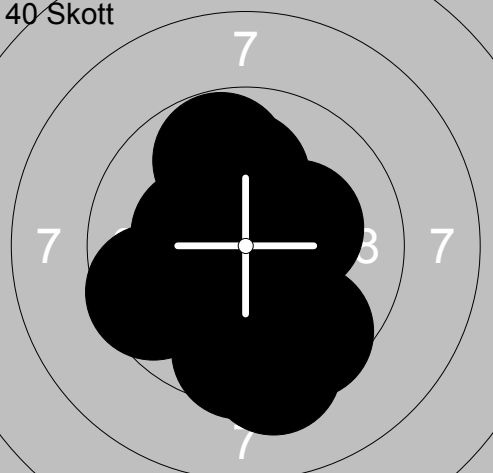
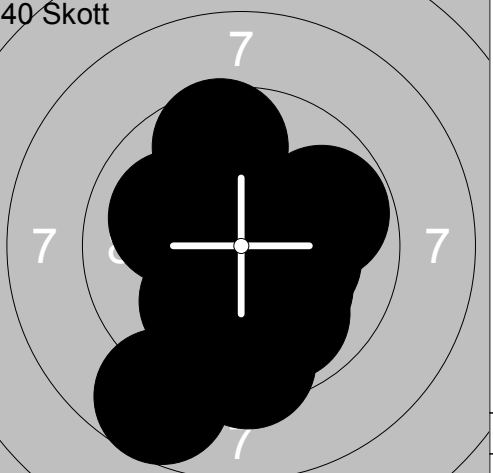
<b>40 Skott</b> 	11: 9.6 ↓ 12: 9.3 ↓ 13: *10.3 → 14: *10.7 ↗ 15: 9.6 ← 16: *10.3 ← 17: 10.1 ↗ 18: 9.8 ↗ 19: 9.6 ↘ 20: 10.1 ↘	<b>40 Skott</b> 		21: 9.8 → 22: 9.6 ↗ 23: *10.2 → 24: 9.9 ↘ 25: *10.6 → 26: 8.7 ↘ 27: 9.4 ↘ 28: *10.2 ↘ 29: 10.0 ↗ 30: 10.1 ↘
	Serie 95.0			Serie 94.0
	Total 193.0			Total 287.0

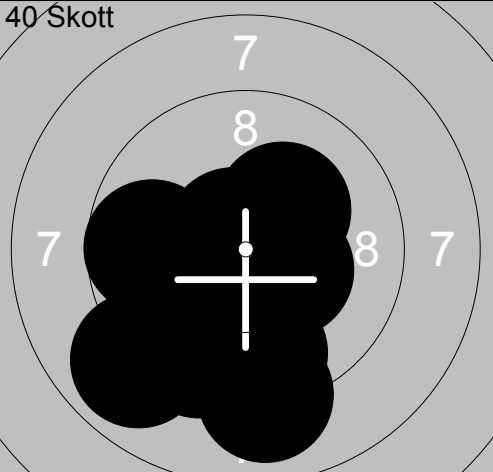
<b>40 Skott</b> 	31: 10.0 ↓ 32: 8.9 ↘ 33: 9.5 ↘ 34: *10.7 ↗ 35: *10.4 ↘ 36: 9.6 ↓ 37: 9.0 ↓ 38: 9.9 ← 39: *10.2 ↗ 40: 9.7 ←			
	Serie 93.0			
	Total 380.0			

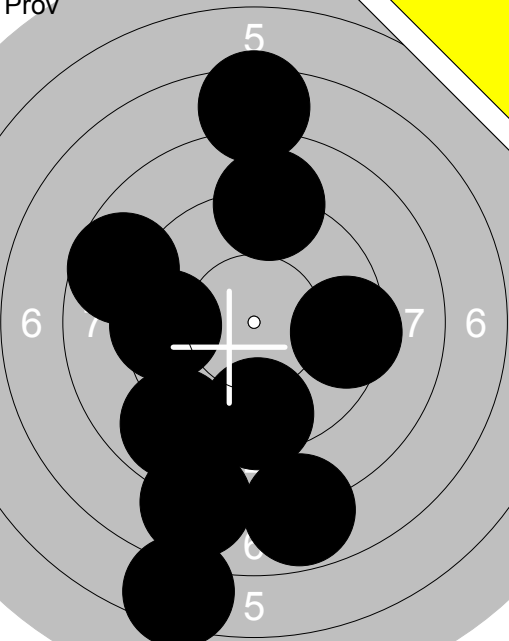
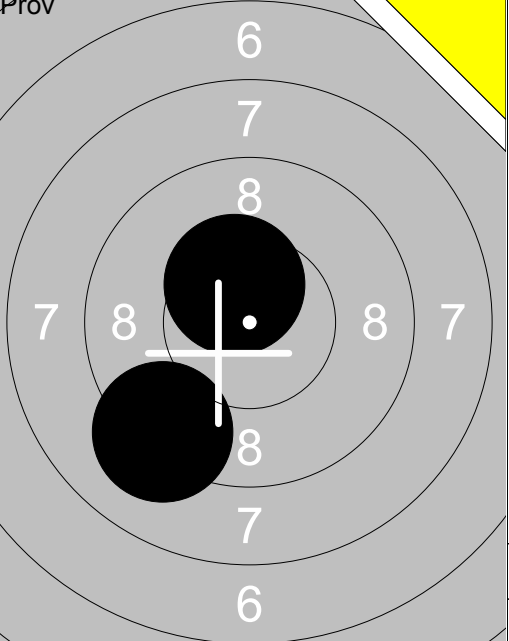
<p>Prov</p> 	<p>1: 8.9 ↙                  2: 7.8 ↓                  3: 9.5 ↓                  4: 9.4 →                  5: 7.9 ↓                  6: 6.4 ↓                  7: 8.7 ↙                  8: 7.5 ↑                  9: 9.5 ←                  10: 9.0 ↑</p> <p>Serie 79.0 Total 0.0</p>	<p>Prov</p> 	<p>11: *10.4 ↗                  12: 9.2 ↙</p> <p>Serie 19.0 Total 0.0</p>
--	--	--	---

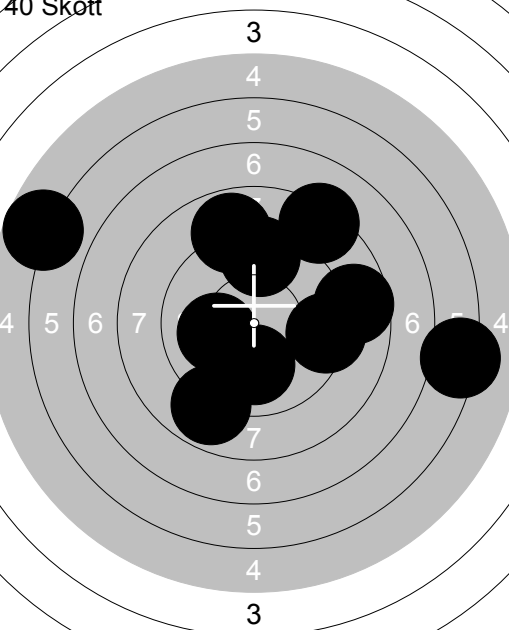
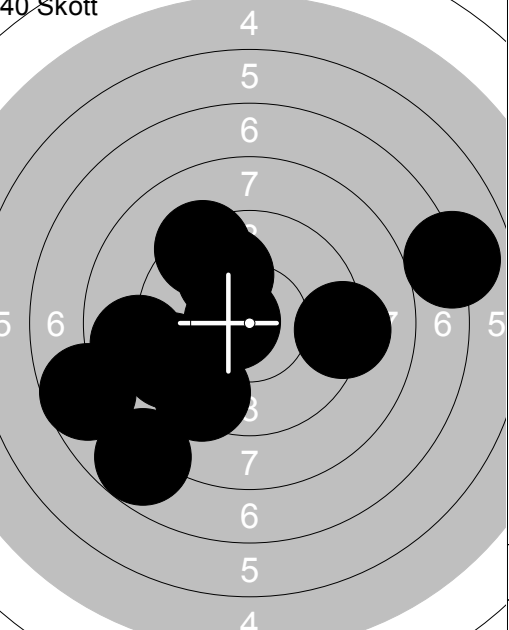
<p>40 Skott</p> 	<p>1: 8.9 ↑                  2: 9.4 ↑                  3: 8.3 ↗                  4: 10.1 ←                  5: 10.0 ↓                  6: 8.6 →                  7: 5.7 ↙                  8: 6.2 →                  9: 8.9 ↓                  10: 9.3 →</p> <p>Serie 81.0 Total 81.0</p>		<p>11: 8.8 ←                  12: 9.3 ←                  13: 9.3 ↗                  14: 7.7 ←                  15: 9.4 ↙                  16: 7.8 ↙                  17: 7.0 →                  18: *10.6 ↙                  19: 9.2 →                  20: 9.9 ↗</p> <p>Serie 84.0 Total 165.0</p>
---	---	---	---

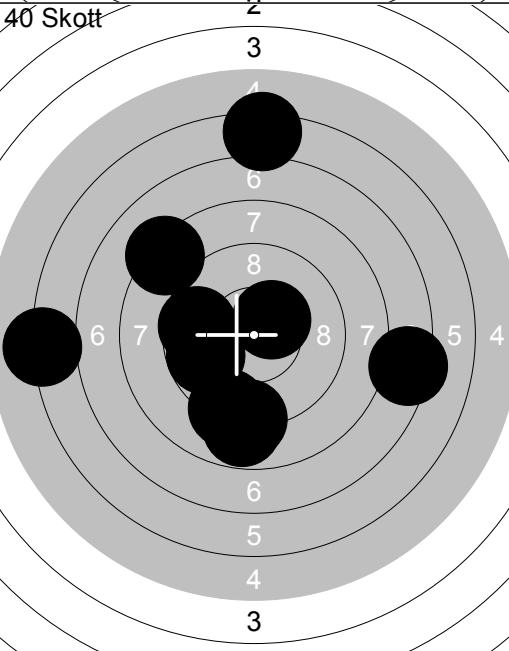
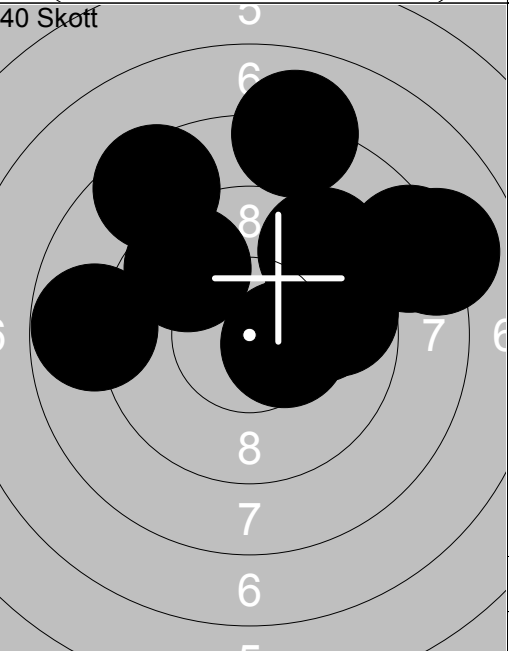
<p>40 Skott</p> 	<p>21: 6.1 ←                  22: 9.0 ↓                  23: *10.4 ↗                  24: 9.6 ←                  25: 8.2 ↙                  26: 9.7 ←                  27: 6.3 ↑                  28: 9.1 ↓                  29: 8.8 ↓                  30: 7.3 →</p> <p>Serie 81.0 Total 246.0</p>	<p>40 Skott</p> 	<p>31: 9.7 →                  32: 8.4 ↗                  33: 8.5 ↙                  34: 8.1 ↑                  35: 9.4 ↗                  36: *10.4 →                  37: 8.1 ↗                  38: 10.0 →                  39: 9.7 ↙                  40: 8.8 ←</p> <p>Serie 87.0 Total 333.0</p>
--	---	--	--

<p>Pröv</p>	<p>1: 9.4 ↗                  2: *10.2 →                  3: 8.5 ↗                  4: 9.4 →                  5: 10.1 ↗                  6: 7.9 ↖                  7: 9.9 ↖                  8: 9.2 ↗                  9: 9.1 ↑                  10: 9.4 ↓</p> <p>Serie 89.0 Total 0.0</p>	<p>Pröv</p>	<p>11: 9.9 ↖                  12: 9.0 ↖                  13: *10.4 ↑                  14: *10.6 ↗                  15: 9.1 ↑                  16: 8.3 →                  17: *10.2 ↗                  18: *10.4 ↑                  19: *10.2 ↓</p> <p>Serie 85.0 Total 0.0</p>
-------------	---	-------------	--

<p>40 Skott</p>	<p>1: 8.8 ↗                  2: *10.5 ↘                  3: *10.3 ↘                  4: *10.2 →                  5: 8.5 ↑                  6: *10.5 ↘                  7: 7.7 ↗                  8: 9.2 ↑                  9: 9.5 →                  10: *10.4 ←</p> <p>Serie 91.0 Total 91.0</p>	<p>40 Skott</p>	<p>11: *10.7 ↑                  12: 9.3 ↗                  13: 9.7 ↑                  14: *10.3 ↓                  15: *10.3 ↘                  16: 8.2 ↑                  17: 9.8 ↑                  18: *10.4 ↖                  19: 9.8 ↘                  20: 9.4 ↘</p> <p>Serie 93.0 Total 184.0</p>
-----------------	---	-----------------	---

<p>40 Skott</p>	<p>21: 9.2 →                  22: 9.3 →                  23: 8.9 ↗                  24: 9.4 →                  25: *10.4 →                  26: 9.1 ↓                  27: 9.3 ↓                  28: 9.0 ↓                  29: 9.8 ←                  30: *10.2 ↗</p> <p>Serie 91.0 Total 275.0</p>	<p>40 Skott</p>	<p>31: 10.0 ↑                  32: 8.6 ↓                  33: *10.8 ↗                  34: *10.9 ↘                  35: 9.8 ←                  36: 9.5 ↖                  37: 9.6 ↘                  38: 8.8 ↖                  39: *10.6 ←                  40: 9.3 ↑</p> <p>Serie 92.0 Total 367.0</p>
-----------------	---	-----------------	--

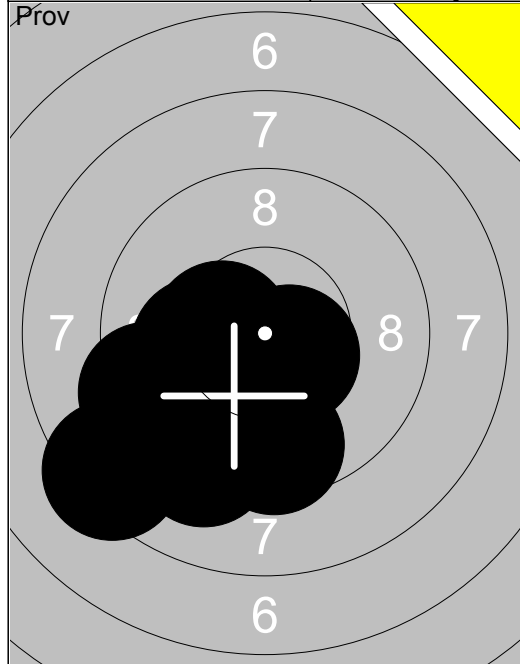

1:	9.6	↓
2:	9.2	↓
3:	8.3	↙
4:	*10.4	←
5:	10.0	↓
6:	9.3	↙
7:	10.1	←
8:	*10.5	↘
9:	10.1	↓
10:	9.5	↓
Serie		94.0
Total		0.0

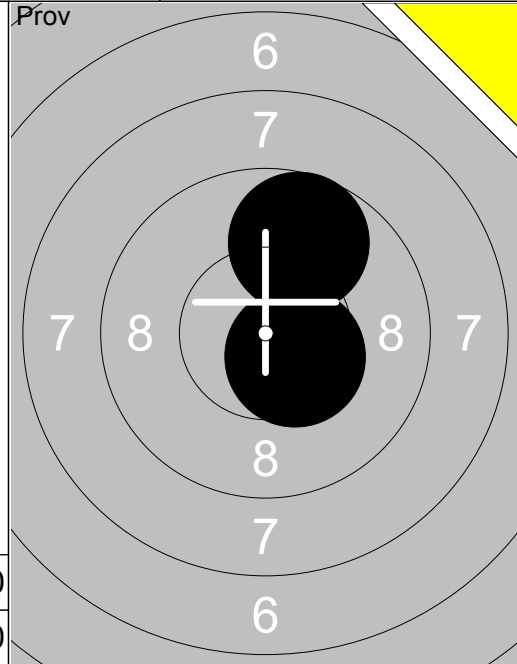

11:	*10.5	↘
12:	9.7	↑
Serie		19.0
Total		0.0

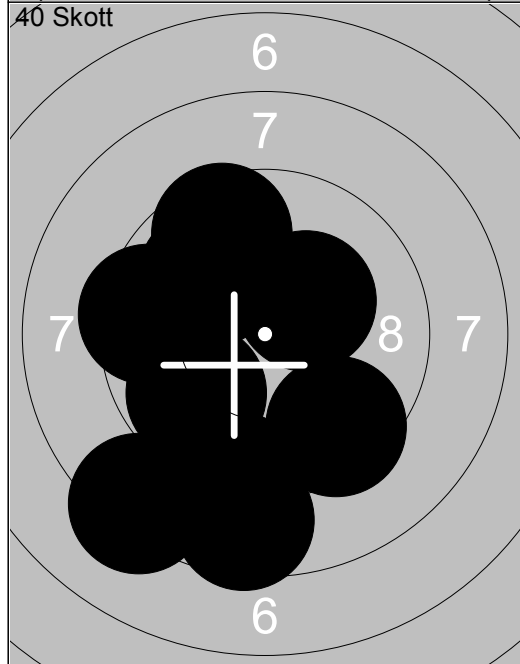

1:	9.6	↑
2:	9.4	←
3:	8.3	↙
4:	9.5	↘
5:	9.1	↓
6:	8.6	↓
7:	9.0	↓
8:	9.8	↙
9:	9.9	↖
10:	*10.3	↗
Serie		89.0
Total		89.0

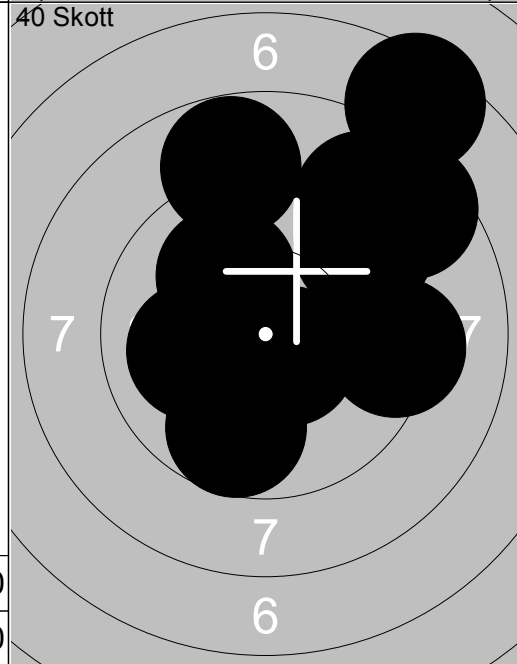

11:	7.4	↗
12:	8.5	↗
13:	10.1	↖
14:	8.8	↑
15:	9.3	↗
16:	9.7	↓
17:	10.0	←
18:	8.8	↗
19:	*10.6	↘
20:	9.3	→
Serie		88.0
Total		177.0

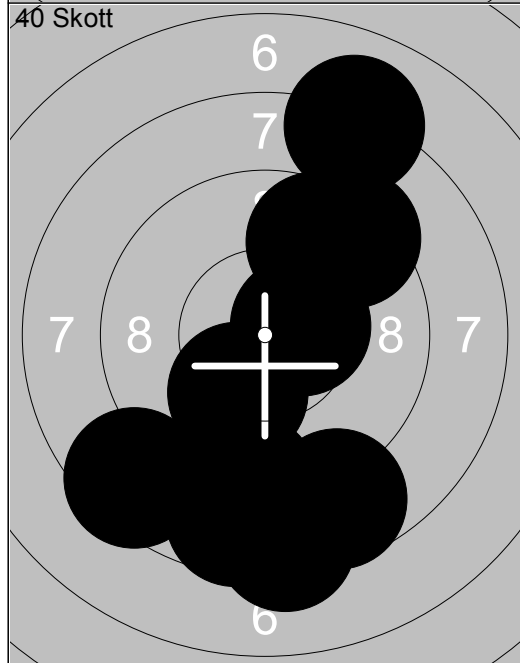

21:	9.3	↗
22:	9.6	↗
23:	10.1	↓
24:	8.0	↗
25:	9.0	↓
26:	*10.5	→
27:	8.5	↙
28:	8.3	↓
29:	8.6	↓
30:	8.7	↓
Serie		87.0
Total		264.0

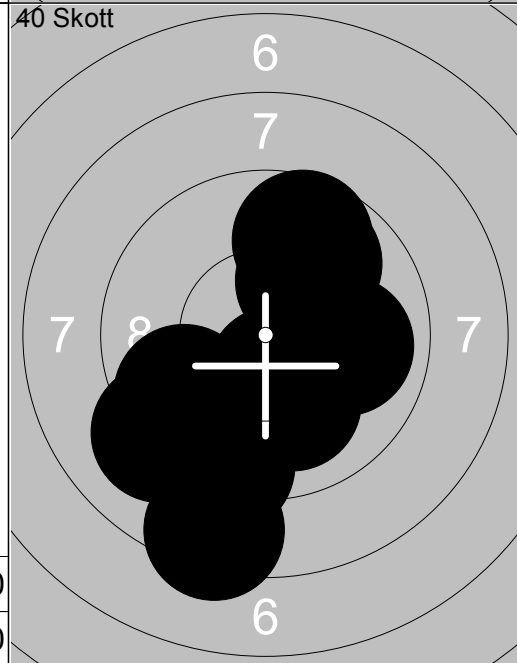

31:	9.7	↙
32:	10.1	↗
33:	9.7	↑
34:	9.9	↗
35:	9.2	↓
36:	10.1	↓
37:	9.9	→
38:	8.4	↓
39:	*10.4	↘
40:	9.1	↙
Serie		92.0
Total		356.0

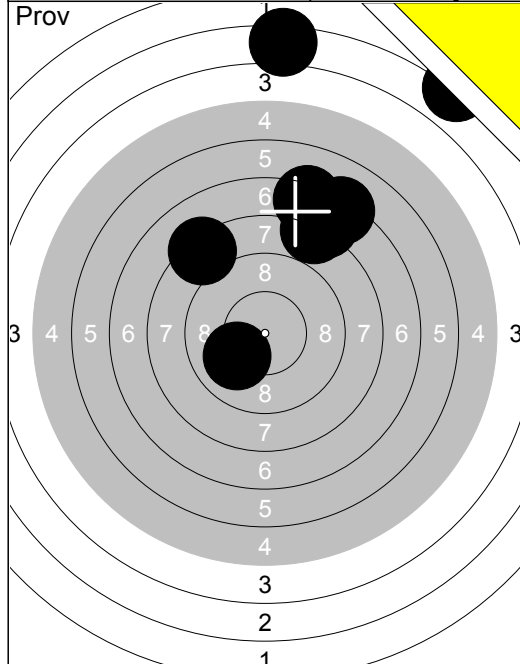

1:	3.3	↑
2:	2.7	↗
3:	7.2	↑
4:	7.7	↗
5:	7.9	↑
6:	10.0	↙
7:	7.2	↗
8:	8.2	↖
Serie		51.0
Total		0.0

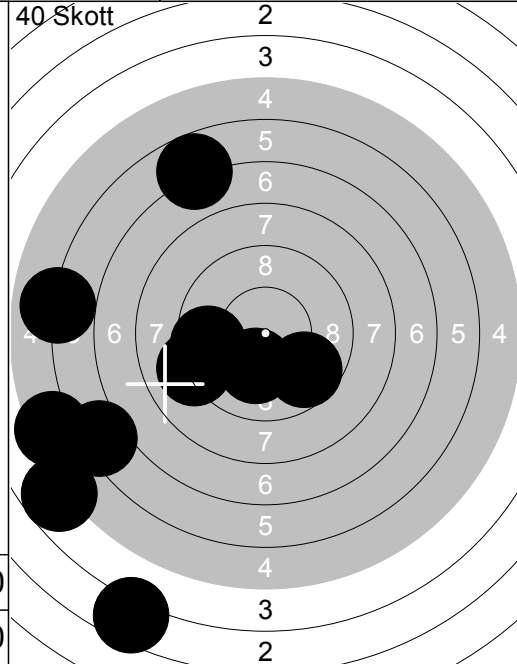

1:	6.7	↖
2:	5.9	↙
3:	9.7	↘
4:	3.5	↘
5:	5.4	↙
6:	6.3	↙
7:	9.1	↙
8:	10.1	↘
9:	4.7	↙
10:	9.6	↙
Serie		66.0
Total		66.0

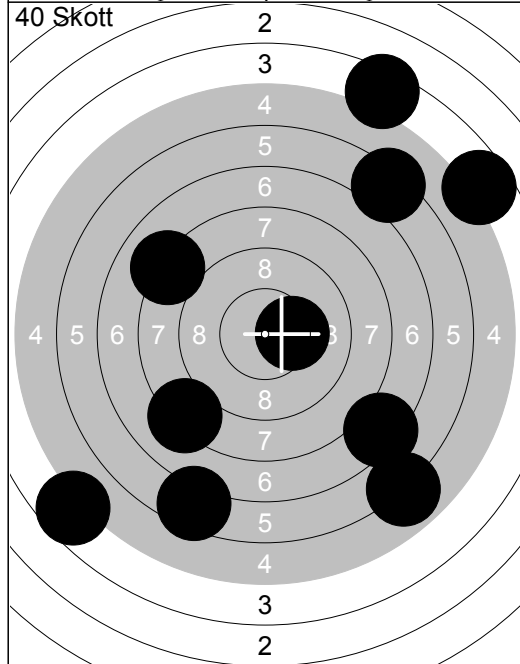

11:	5.9	↘
12:	6.5	↘
13:	4.6	↙
14:	6.2	↗
15:	7.3	↘
16:	4.6	↗
17:	*10.3	→
18:	8.2	↙
19:	8.1	↙
20:	4.4	↗
Serie		62.0
Total		128.0

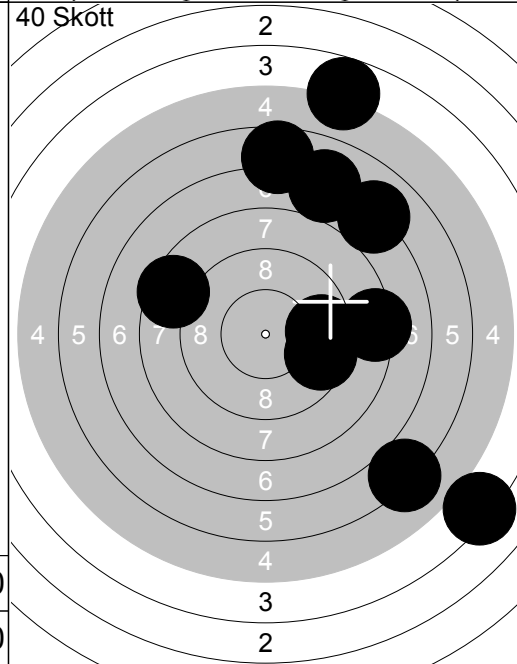

21:	8.2	→
22:	6.1	↘
23:	9.6	→
24:	6.6	↑
25:	9.5	→
26:	4.1	↘
27:	7.0	↗
28:	4.7	↑
29:	7.0	↑
30:	8.4	↙
Serie		68.0
Total		196.0

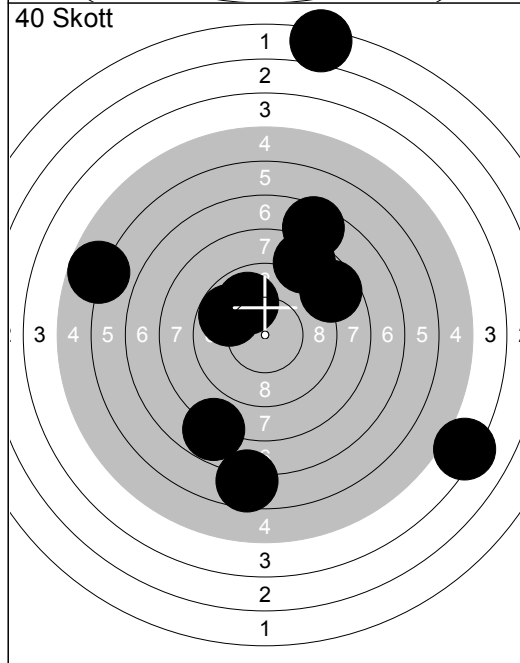

31:	4.2	↘
32:	7.8	↘
33:	6.6	↘
34:	5.7	↙
35:	8.5	↗
36:	7.5	↗
37:	8.6	↗
38:	9.8	↙
39:	2.2	↑
40:	9.9	↖
Serie		65.0
Total		261.0

<p>Prov</p> <p style="text-align: center;">6 7 8 7 8 7 7 6</p>	<p>1: 9.7 →</p> <p>2: 9.7 →</p> <p>3: 9.4 →</p> <p>4: *10.8 ↗</p> <p>5: 9.3 →</p> <p>6: 10.0 ↓</p> <p>7: *10.2 ↘</p> <p>8: 10.1 ↓</p> <p>9: *10.5 ↘</p> <p>10: *10.3 ↘</p> <hr/> <p>Serie 96.0</p> <p>Total 0.0</p>	<p>Prov</p> <p style="text-align: center;">6 7 8 7 8 7 7 6</p>	<p>11: 9.1 →</p> <p>12: *10.4 →</p> <p>13: *10.5 ↗</p> <p>14: *10.7 ↘</p> <hr/> <p>Serie 39.0</p> <p>Total 0.0</p>
<p>40 Skott</p> <p style="text-align: center;">6 7 8 7 8 7 7 6</p>	<p>1: *10.2 ↘</p> <p>2: *10.2 ↗</p> <p>3: *10.2 →</p> <p>4: *10.8 ↘</p> <p>5: 10.1 ↓</p> <p>6: *10.7 ↘</p> <p>7: *10.4 →</p> <p>8: *10.3 ↓</p> <p>9: *10.3 ↘</p> <p>10: *10.8 →</p> <hr/> <p>Serie 100.0</p> <p>Total 100.0</p>	<p>40 Skott</p> <p style="text-align: center;">6 7 8 7 8 7 7 6</p>	<p>11: *10.5 ↘</p> <p>12: 9.3 ↘</p> <p>13: 9.8 ↓</p> <p>14: 8.9 ↘</p> <p>15: *10.2 ↘</p> <p>16: 10.1 ↘</p> <p>17: *10.6 ↘</p> <p>18: *10.4 ↘</p> <p>19: 10.0 ↓</p> <p>20: 9.6 ↓</p> <hr/> <p>Serie 95.0</p> <p>Total 195.0</p>
<p>40 Skott</p> <p style="text-align: center;">6 7 8 7 8 7 7 6</p>	<p>21: *10.2 ↘</p> <p>22: *10.4 ↘</p> <p>23: 9.7 ↘</p> <p>24: 10.0 ↓</p> <p>25: *10.6 ↓</p> <p>26: *10.4 ↓</p> <p>27: 9.8 ↘</p> <p>28: *10.4 ↘</p> <p>29: 9.1 ↘</p> <p>30: 10.0 ↓</p> <hr/> <p>Serie 97.0</p> <p>Total 292.0</p>	<p>40 Skott</p> <p style="text-align: center;">6 7 8 7 8 7 7 6</p>	<p>31: 9.4 ↓</p> <p>32: *10.2 ↘</p> <p>33: *10.8 ↘</p> <p>34: *10.6 ↘</p> <p>35: *10.5 ↓</p> <p>36: *10.5 ↘</p> <p>37: 9.4 →</p> <p>38: *10.2 ↘</p> <p>39: 9.7 ↘</p> <p>40: 10.1 ←</p> <hr/> <p>Serie 97.0</p> <p>Total 389.0</p>



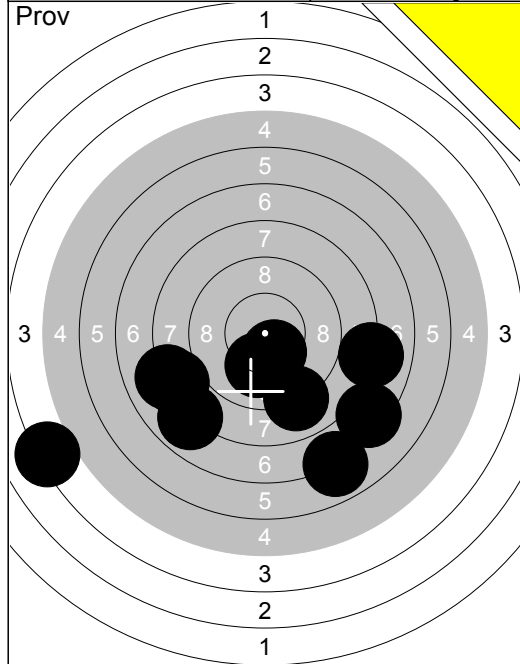

1:	4.1	↙
2:	*10.4	↘
3:	10.1	↘
4:	6.9	↘
5:	7.3	↘
6:	8.0	→
7:	8.0	↙
8:	9.0	↘
9:	8.2	↙
10:	7.9	↘
Serie		79.9
Total		0.0

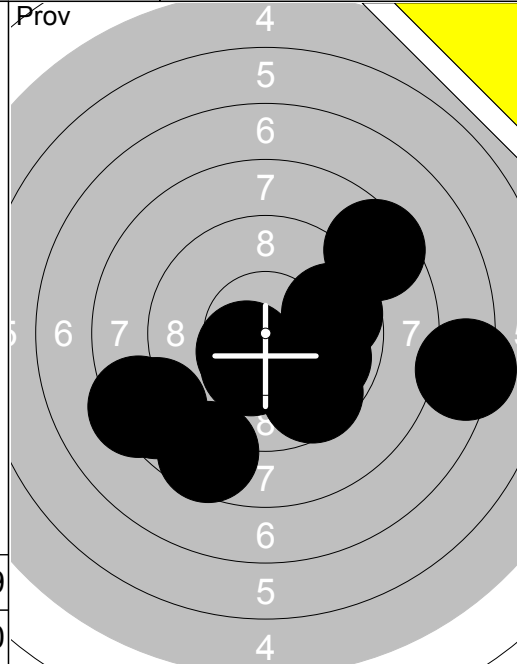

11:	8.5	↗
12:	8.6	↘
13:	*10.3	↘
14:	9.6	↘
15:	7.3	→
16:	9.9	→
17:	8.6	↙
18:	*10.5	↘
19:	8.3	↙
20:	9.7	→
Serie		91.3
Total		0.0

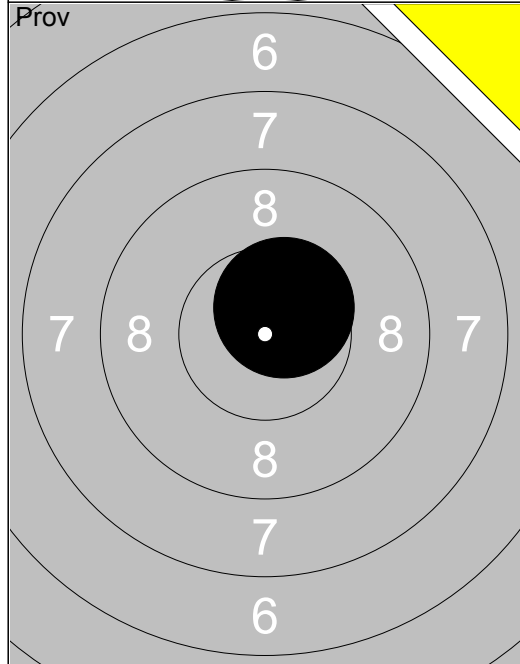

21:	*10.5	↗
Serie		10.5
Total		0.0

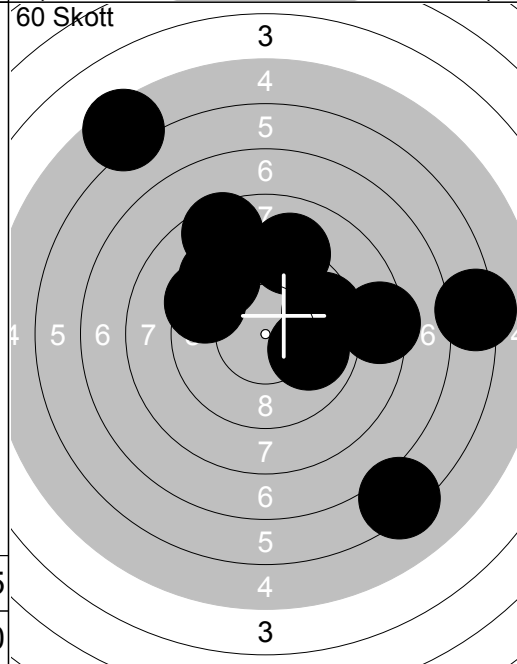

1:	5.4	↖
2:	6.3	↘
3:	8.5	↗
4:	9.1	↗
5:	9.9	→
6:	9.3	↗
7:	9.6	→
8:	9.4	↙
9:	6.3	→
10:	8.4	→
Serie		82.2
Total		82.2

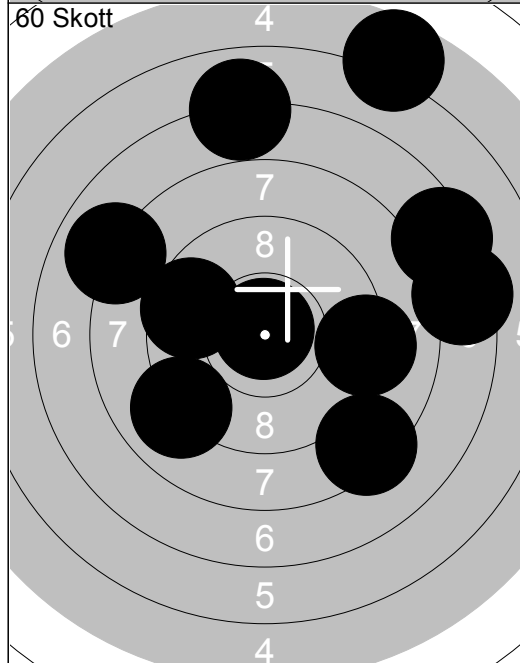

11:	9.6	↙
12:	*10.8	↗
13:	7.9	↙
14:	9.2	→
15:	6.9	↗
16:	9.0	↙
17:	7.4	↗
18:	5.6	↗
19:	7.4	→
20:	8.3	↘
Serie		82.1
Total		164.3

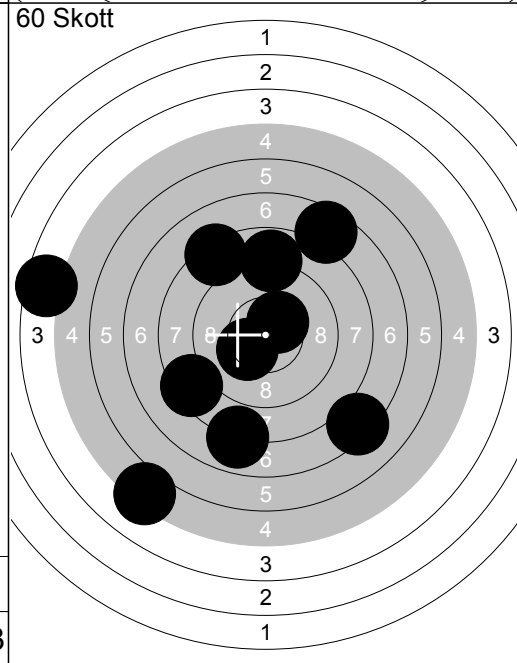

21:	8.2	↖
22:	*10.4	↗
23:	7.2	↘
24:	8.8	↗
25:	5.2	↘
26:	4.4	↙
27:	*10.3	↘
28:	8.4	↙
29:	7.9	↘
30:	7.5	↗
Serie		78.3
Total		242.6



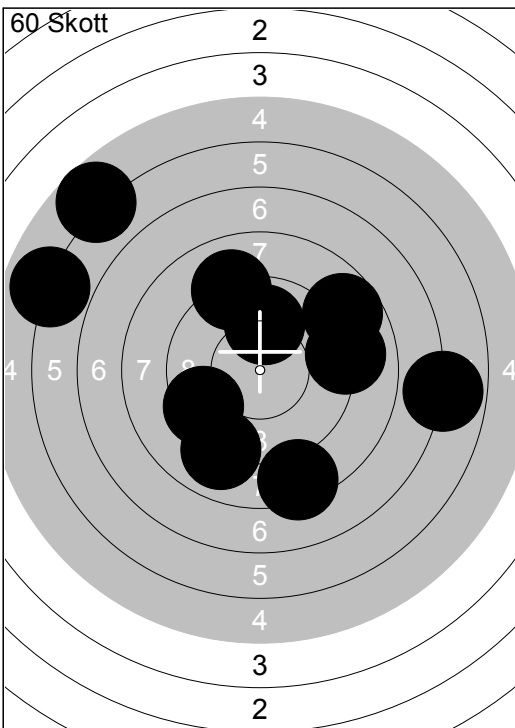

31:	9.1	↗
32:	8.4	↘
33:	9.0	↘
34:	6.8	→
35:	9.9	↑
36:	9.0	→
37:	9.5	↙
38:	5.7	↖
39:	8.7	↗
40:	5.9	↖

Serie	82.0
Total	324.6

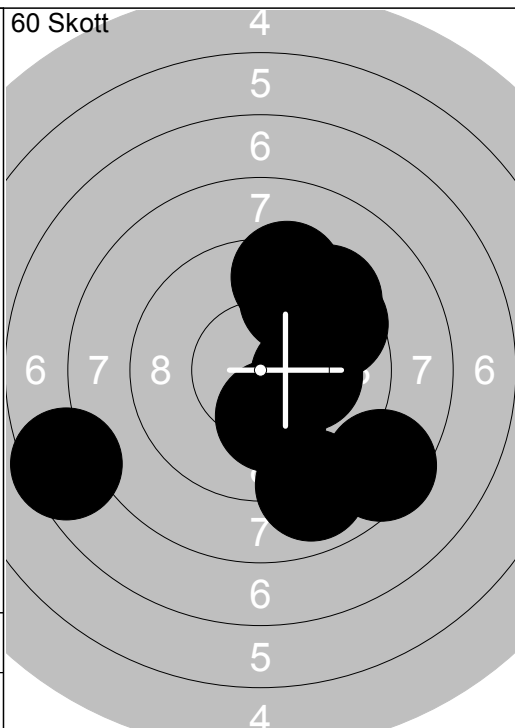

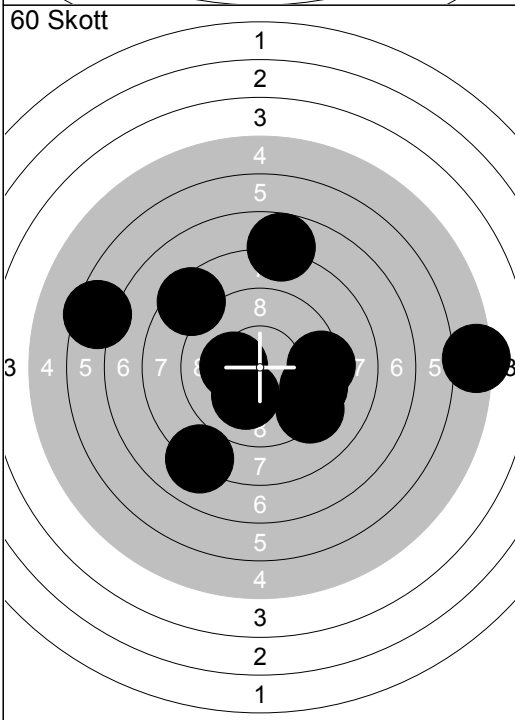

41:	*10.2	→
42:	9.6	↗
43:	7.5	↖
44:	9.4	↗
45:	9.7	↗
46:	9.4	↑
47:	8.9	↘
48:	9.7	↗
49:	8.5	↘
50:	*10.2	↘

Serie	93.1
Total	417.7

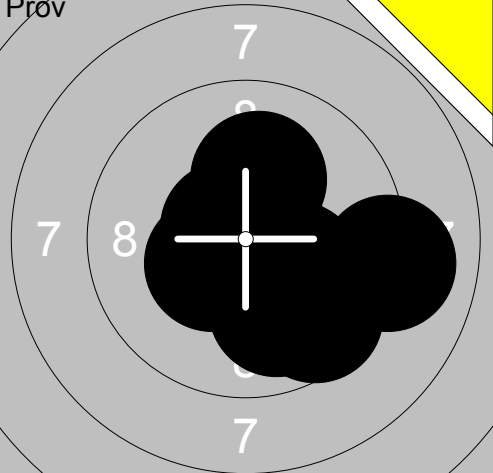
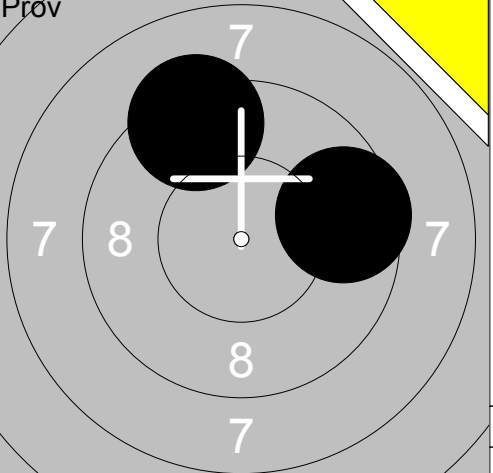
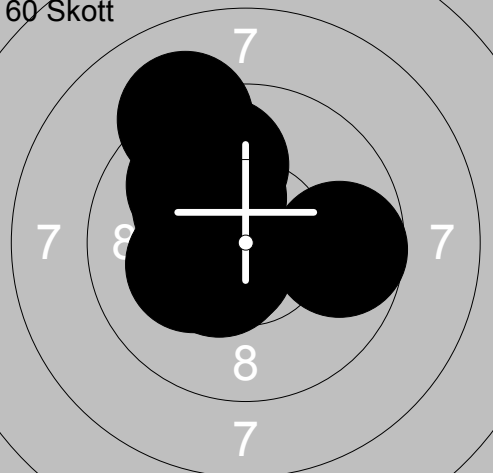
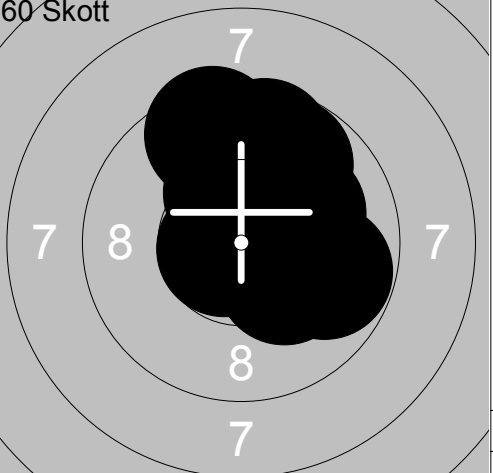

51:	8.4	↖
52:	10.1	↘
53:	9.2	↘
54:	9.3	→
55:	5.2	→
56:	7.7	↑
57:	8.1	↘
58:	6.5	↖
59:	9.5	↘
60:	*10.3	↖

Serie	84.3
Total	502.0

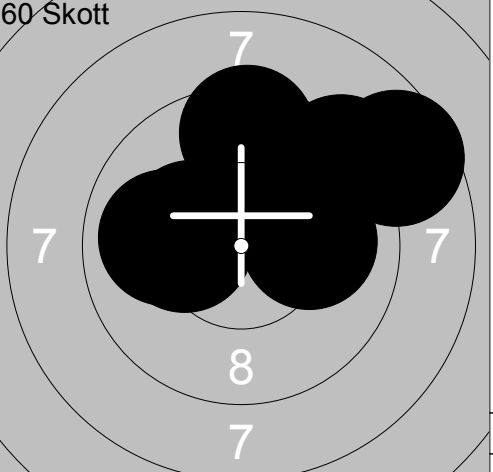
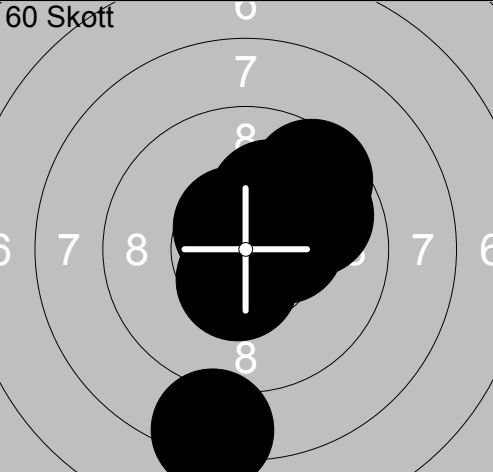
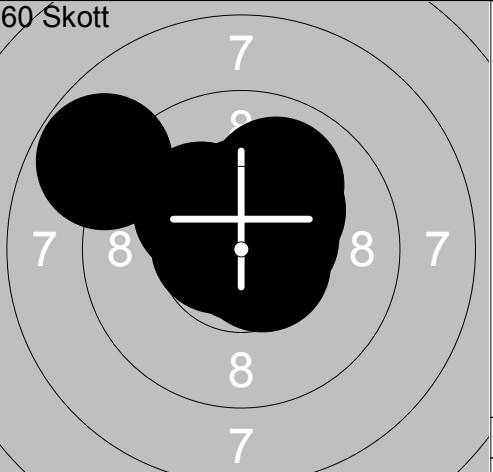
Pröv	Pröv																																																	
		<table border="1" style="width:100%; border-collapse: collapse;"> <tr> <td>1: *10.7</td><td>↘</td> <td>11: 9.6</td><td>→</td> </tr> <tr> <td>2: 9.6</td><td>↘</td> <td>12: 9.3</td><td>↑</td> </tr> <tr> <td>3: *10.4</td><td>↙</td> <td></td><td></td> </tr> <tr> <td>4: *10.2</td><td>↘</td> <td></td><td></td> </tr> <tr> <td>5: *10.9</td><td>→</td> <td></td><td></td> </tr> <tr> <td>6: *10.8</td><td>↑</td> <td></td><td></td> </tr> <tr> <td>7: 9.9</td><td>↘</td> <td></td><td></td> </tr> <tr> <td>8: 10.1</td><td>↑</td> <td></td><td></td> </tr> <tr> <td>9: *10.7</td><td>↗</td> <td></td><td></td> </tr> <tr> <td>10: 9.0</td><td>→</td> <td></td><td></td> </tr> <tr> <td colspan="2">Serie 102.3</td> <td colspan="2">Serie 18.9</td> </tr> <tr> <td colspan="2">Total 0.0</td> <td colspan="2">Total 0.0</td> </tr> </table>	1: *10.7	↘	11: 9.6	→	2: 9.6	↘	12: 9.3	↑	3: *10.4	↙			4: *10.2	↘			5: *10.9	→			6: *10.8	↑			7: 9.9	↘			8: 10.1	↑			9: *10.7	↗			10: 9.0	→			Serie 102.3		Serie 18.9		Total 0.0		Total 0.0	
1: *10.7	↘	11: 9.6	→																																															
2: 9.6	↘	12: 9.3	↑																																															
3: *10.4	↙																																																	
4: *10.2	↘																																																	
5: *10.9	→																																																	
6: *10.8	↑																																																	
7: 9.9	↘																																																	
8: 10.1	↑																																																	
9: *10.7	↗																																																	
10: 9.0	→																																																	
Serie 102.3		Serie 18.9																																																
Total 0.0		Total 0.0																																																
<b>60 Skott</b> 	<b>60 Skott</b> 	<table border="1" style="width:100%; border-collapse: collapse;"> <tr> <td>1: *10.2</td><td>←</td> <td>11: *10.2</td><td>↘</td> </tr> <tr> <td>2: *10.5</td><td>↙</td> <td>12: 9.8</td><td>↑</td> </tr> <tr> <td>3: 9.9</td><td>↗</td> <td>13: *10.3</td><td>↑</td> </tr> <tr> <td>4: 9.9</td><td>↑</td> <td>14: 9.5</td><td>↑</td> </tr> <tr> <td>5: 9.7</td><td>↗</td> <td>15: 9.6</td><td>↑</td> </tr> <tr> <td>6: *10.2</td><td>↗</td> <td>16: *10.7</td><td>←</td> </tr> <tr> <td>7: *10.6</td><td>↙</td> <td>17: *10.3</td><td>↑</td> </tr> <tr> <td>8: *10.3</td><td>↗</td> <td>18: 10.1</td><td>↗</td> </tr> <tr> <td>9: 9.1</td><td>↗</td> <td>19: 9.8</td><td>→</td> </tr> <tr> <td>10: 9.7</td><td>→</td> <td>20: *10.6</td><td>→</td> </tr> <tr> <td colspan="2">Serie 100.1</td> <td colspan="2">Serie 100.9</td> </tr> <tr> <td colspan="2">Total 100.1</td> <td colspan="2">Total 201.0</td> </tr> </table>	1: *10.2	←	11: *10.2	↘	2: *10.5	↙	12: 9.8	↑	3: 9.9	↗	13: *10.3	↑	4: 9.9	↑	14: 9.5	↑	5: 9.7	↗	15: 9.6	↑	6: *10.2	↗	16: *10.7	←	7: *10.6	↙	17: *10.3	↑	8: *10.3	↗	18: 10.1	↗	9: 9.1	↗	19: 9.8	→	10: 9.7	→	20: *10.6	→	Serie 100.1		Serie 100.9		Total 100.1		Total 201.0	
1: *10.2	←	11: *10.2	↘																																															
2: *10.5	↙	12: 9.8	↑																																															
3: 9.9	↗	13: *10.3	↑																																															
4: 9.9	↑	14: 9.5	↑																																															
5: 9.7	↗	15: 9.6	↑																																															
6: *10.2	↗	16: *10.7	←																																															
7: *10.6	↙	17: *10.3	↑																																															
8: *10.3	↗	18: 10.1	↗																																															
9: 9.1	↗	19: 9.8	→																																															
10: 9.7	→	20: *10.6	→																																															
Serie 100.1		Serie 100.9																																																
Total 100.1		Total 201.0																																																
<b>60 Skott</b> 	<b>60 Skott</b> 	<table border="1" style="width:100%; border-collapse: collapse;"> <tr> <td>21: 9.1</td><td>→</td> <td>31: 10.1</td><td>↗</td> </tr> <tr> <td>22: 10.1</td><td>←</td> <td>32: 9.5</td><td>↑</td> </tr> <tr> <td>23: 9.5</td><td>→</td> <td>33: *10.2</td><td>←</td> </tr> <tr> <td>24: *10.7</td><td>↑</td> <td>34: *10.3</td><td>←</td> </tr> <tr> <td>25: 9.4</td><td>←</td> <td>35: *10.2</td><td>↗</td> </tr> <tr> <td>26: *10.5</td><td>↗</td> <td>36: 10.0</td><td>←</td> </tr> <tr> <td>27: *10.2</td><td>←</td> <td>37: 10.1</td><td>→</td> </tr> <tr> <td>28: *10.2</td><td>↑</td> <td>38: *10.2</td><td>↑</td> </tr> <tr> <td>29: 10.1</td><td>↑</td> <td>39: 9.2</td><td>↗</td> </tr> <tr> <td>30: *10.6</td><td>↑</td> <td>40: 8.6</td><td>↗</td> </tr> <tr> <td colspan="2">Serie 100.4</td> <td colspan="2">Serie 98.4</td> </tr> <tr> <td colspan="2">Total 301.4</td> <td colspan="2">Total 399.8</td> </tr> </table>	21: 9.1	→	31: 10.1	↗	22: 10.1	←	32: 9.5	↑	23: 9.5	→	33: *10.2	←	24: *10.7	↑	34: *10.3	←	25: 9.4	←	35: *10.2	↗	26: *10.5	↗	36: 10.0	←	27: *10.2	←	37: 10.1	→	28: *10.2	↑	38: *10.2	↑	29: 10.1	↑	39: 9.2	↗	30: *10.6	↑	40: 8.6	↗	Serie 100.4		Serie 98.4		Total 301.4		Total 399.8	
21: 9.1	→	31: 10.1	↗																																															
22: 10.1	←	32: 9.5	↑																																															
23: 9.5	→	33: *10.2	←																																															
24: *10.7	↑	34: *10.3	←																																															
25: 9.4	←	35: *10.2	↗																																															
26: *10.5	↗	36: 10.0	←																																															
27: *10.2	←	37: 10.1	→																																															
28: *10.2	↑	38: *10.2	↑																																															
29: 10.1	↑	39: 9.2	↗																																															
30: *10.6	↑	40: 8.6	↗																																															
Serie 100.4		Serie 98.4																																																
Total 301.4		Total 399.8																																																
<b>60 Skott</b> 	<b>60 Skott</b> 	<table border="1" style="width:100%; border-collapse: collapse;"> <tr> <td>41: 9.9</td><td>↗</td> <td>51: 10.0</td><td>↑</td> </tr> <tr> <td>42: *10.4</td><td>→</td> <td>52: 8.8</td><td>↙</td> </tr> <tr> <td>43: *10.2</td><td>↑</td> <td>53: *10.4</td><td>↑</td> </tr> <tr> <td>44: 8.3</td><td>↘</td> <td>54: *10.7</td><td>←</td> </tr> <tr> <td>45: *10.6</td><td>→</td> <td>55: *10.9</td><td>↘</td> </tr> <tr> <td>46: 9.6</td><td>↗</td> <td>56: *10.2</td><td>↗</td> </tr> <tr> <td>47: *10.5</td><td>↘</td> <td>57: *10.2</td><td>↗</td> </tr> <tr> <td>48: *10.5</td><td>↑</td> <td>58: *10.2</td><td>↑</td> </tr> <tr> <td>49: *10.6</td><td>↗</td> <td>59: *10.6</td><td>↘</td> </tr> <tr> <td>50: *10.6</td><td>↑</td> <td>60: *10.5</td><td>→</td> </tr> <tr> <td colspan="2">Serie 101.2</td> <td colspan="2">Serie 102.5</td> </tr> <tr> <td colspan="2">Total 501.0</td> <td colspan="2">Total 603.5</td> </tr> </table>	41: 9.9	↗	51: 10.0	↑	42: *10.4	→	52: 8.8	↙	43: *10.2	↑	53: *10.4	↑	44: 8.3	↘	54: *10.7	←	45: *10.6	→	55: *10.9	↘	46: 9.6	↗	56: *10.2	↗	47: *10.5	↘	57: *10.2	↗	48: *10.5	↑	58: *10.2	↑	49: *10.6	↗	59: *10.6	↘	50: *10.6	↑	60: *10.5	→	Serie 101.2		Serie 102.5		Total 501.0		Total 603.5	
41: 9.9	↗	51: 10.0	↑																																															
42: *10.4	→	52: 8.8	↙																																															
43: *10.2	↑	53: *10.4	↑																																															
44: 8.3	↘	54: *10.7	←																																															
45: *10.6	→	55: *10.9	↘																																															
46: 9.6	↗	56: *10.2	↗																																															
47: *10.5	↘	57: *10.2	↗																																															
48: *10.5	↑	58: *10.2	↑																																															
49: *10.6	↗	59: *10.6	↘																																															
50: *10.6	↑	60: *10.5	→																																															
Serie 101.2		Serie 102.5																																																
Total 501.0		Total 603.5																																																

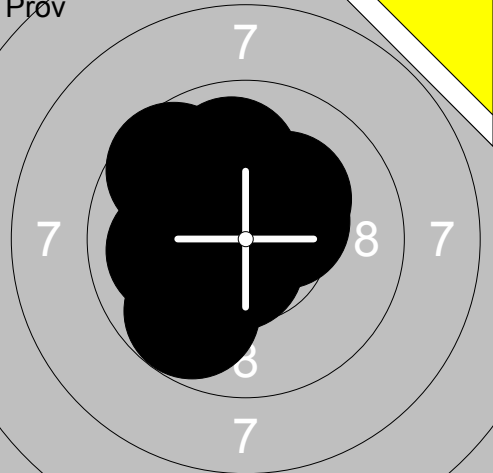
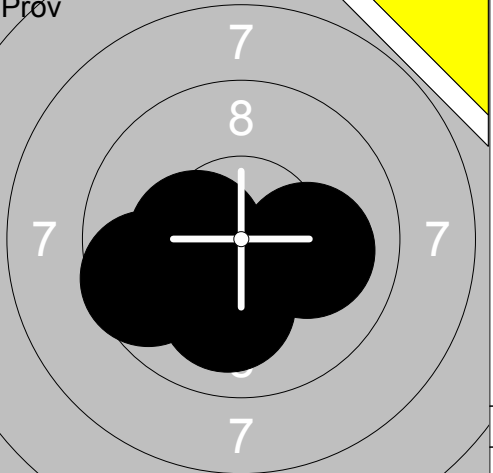
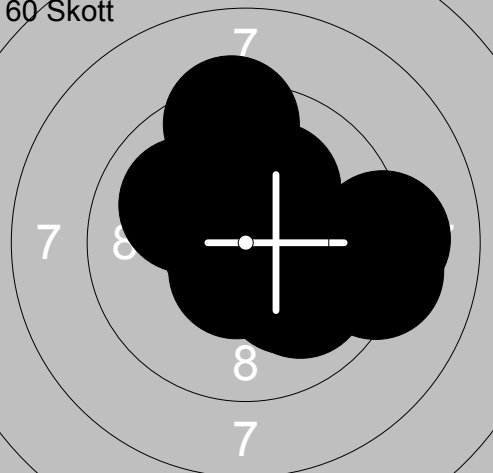
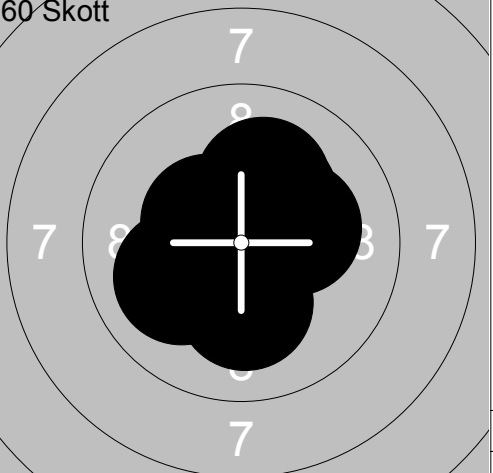
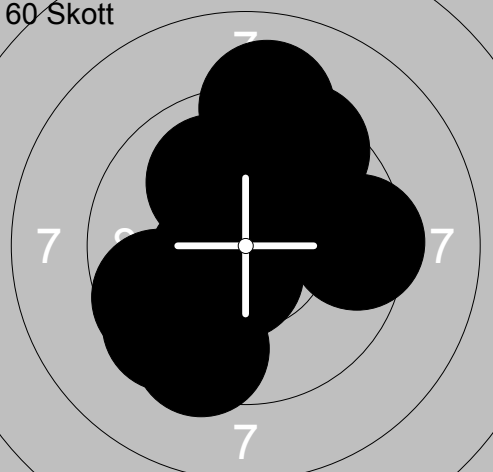
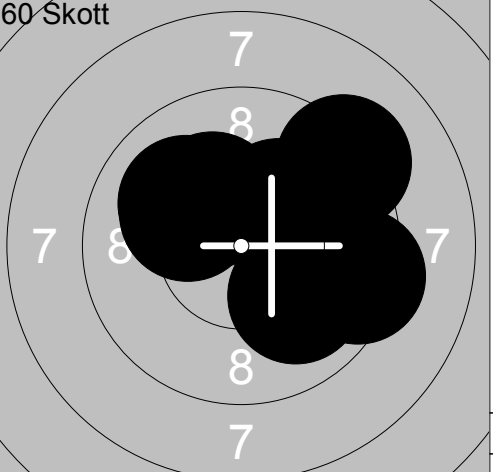
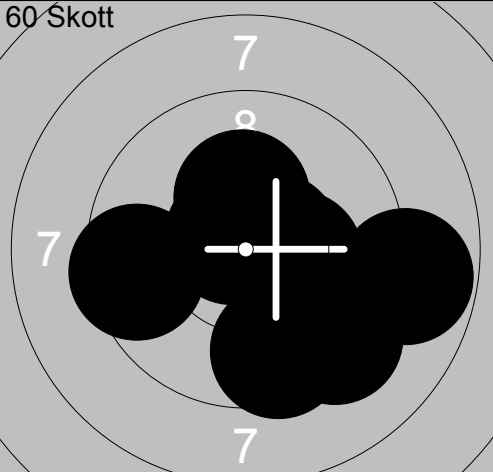
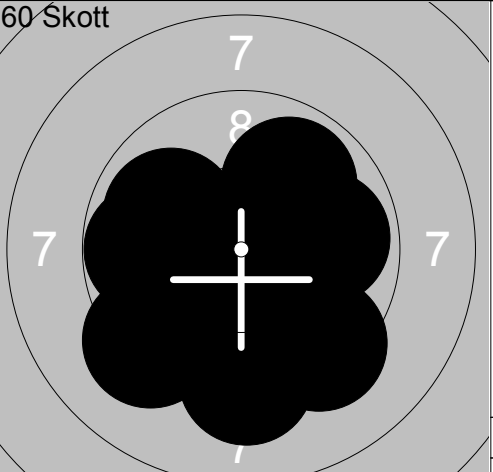
Pröv		Pröv																																																	
	<table border="1" style="width:100%; border-collapse: collapse;"> <tr><td>1: *10.4</td><td>↗</td></tr> <tr><td>2: *10.2</td><td>↗</td></tr> <tr><td>3: *10.6</td><td>↓</td></tr> <tr><td>4: 10.0</td><td>↑</td></tr> <tr><td>5: *10.3</td><td>←</td></tr> <tr><td>6: *10.2</td><td>←</td></tr> <tr><td>7: 10.0</td><td>←</td></tr> <tr><td>8: 9.6</td><td>↗</td></tr> <tr><td>9: *10.2</td><td>↗</td></tr> <tr><td>10: 9.8</td><td>↓</td></tr> <tr><td colspan="2"><b>Serie</b> 101.3</td></tr> <tr><td colspan="2"><b>Total</b> 0.0</td></tr> </table>	1: *10.4	↗	2: *10.2	↗	3: *10.6	↓	4: 10.0	↑	5: *10.3	←	6: *10.2	←	7: 10.0	←	8: 9.6	↗	9: *10.2	↗	10: 9.8	↓	<b>Serie</b> 101.3		<b>Total</b> 0.0			<table border="1" style="width:100%; border-collapse: collapse;"> <tr><td>11: 9.6</td><td>←</td></tr> <tr><td>12: 10.1</td><td>↓</td></tr> <tr><td>13: 10.1</td><td>←</td></tr> <tr><td>14: *10.4</td><td>←</td></tr> <tr><td>15: 10.1</td><td>→</td></tr> <tr><td colspan="2"><b>Serie</b> 50.3</td></tr> <tr><td colspan="2"><b>Total</b> 0.0</td></tr> </table>	11: 9.6	←	12: 10.1	↓	13: 10.1	←	14: *10.4	←	15: 10.1	→	<b>Serie</b> 50.3		<b>Total</b> 0.0											
1: *10.4	↗																																																		
2: *10.2	↗																																																		
3: *10.6	↓																																																		
4: 10.0	↑																																																		
5: *10.3	←																																																		
6: *10.2	←																																																		
7: 10.0	←																																																		
8: 9.6	↗																																																		
9: *10.2	↗																																																		
10: 9.8	↓																																																		
<b>Serie</b> 101.3																																																			
<b>Total</b> 0.0																																																			
11: 9.6	←																																																		
12: 10.1	↓																																																		
13: 10.1	←																																																		
14: *10.4	←																																																		
15: 10.1	→																																																		
<b>Serie</b> 50.3																																																			
<b>Total</b> 0.0																																																			
<b>60 Skott</b> 	<table border="1" style="width:100%; border-collapse: collapse;"> <tr><td>1: *10.4</td><td>↗</td></tr> <tr><td>2: 9.4</td><td>↑</td></tr> <tr><td>3: *10.6</td><td>↓</td></tr> <tr><td>4: 9.1</td><td>→</td></tr> <tr><td>5: 10.0</td><td>↓</td></tr> <tr><td>6: *10.7</td><td>↓</td></tr> <tr><td>7: 10.1</td><td>↓</td></tr> <tr><td>8: 10.0</td><td>↗</td></tr> <tr><td>9: *10.2</td><td>↗</td></tr> <tr><td>10: 9.2</td><td>→</td></tr> <tr><td colspan="2"><b>Serie</b> 99.7</td></tr> <tr><td colspan="2"><b>Total</b> 99.7</td></tr> </table>	1: *10.4	↗	2: 9.4	↑	3: *10.6	↓	4: 9.1	→	5: 10.0	↓	6: *10.7	↓	7: 10.1	↓	8: 10.0	↗	9: *10.2	↗	10: 9.2	→	<b>Serie</b> 99.7		<b>Total</b> 99.7		<b>60 Skott</b> 	<table border="1" style="width:100%; border-collapse: collapse;"> <tr><td>11: *10.2</td><td>↓</td></tr> <tr><td>12: *10.7</td><td>←</td></tr> <tr><td>13: 10.0</td><td>←</td></tr> <tr><td>14: *10.5</td><td>←</td></tr> <tr><td>15: *10.3</td><td>↗</td></tr> <tr><td>16: *10.4</td><td>↖</td></tr> <tr><td>17: *10.8</td><td>↓</td></tr> <tr><td>18: 10.1</td><td>↗</td></tr> <tr><td>19: *10.2</td><td>→</td></tr> <tr><td>20: *10.6</td><td>↗</td></tr> <tr><td colspan="2"><b>Serie</b> 103.8</td></tr> <tr><td colspan="2"><b>Total</b> 203.5</td></tr> </table>	11: *10.2	↓	12: *10.7	←	13: 10.0	←	14: *10.5	←	15: *10.3	↗	16: *10.4	↖	17: *10.8	↓	18: 10.1	↗	19: *10.2	→	20: *10.6	↗	<b>Serie</b> 103.8		<b>Total</b> 203.5	
1: *10.4	↗																																																		
2: 9.4	↑																																																		
3: *10.6	↓																																																		
4: 9.1	→																																																		
5: 10.0	↓																																																		
6: *10.7	↓																																																		
7: 10.1	↓																																																		
8: 10.0	↗																																																		
9: *10.2	↗																																																		
10: 9.2	→																																																		
<b>Serie</b> 99.7																																																			
<b>Total</b> 99.7																																																			
11: *10.2	↓																																																		
12: *10.7	←																																																		
13: 10.0	←																																																		
14: *10.5	←																																																		
15: *10.3	↗																																																		
16: *10.4	↖																																																		
17: *10.8	↓																																																		
18: 10.1	↗																																																		
19: *10.2	→																																																		
20: *10.6	↗																																																		
<b>Serie</b> 103.8																																																			
<b>Total</b> 203.5																																																			
<b>60 Skott</b> 	<table border="1" style="width:100%; border-collapse: collapse;"> <tr><td>21: 9.5</td><td>↗</td></tr> <tr><td>22: *10.6</td><td>↓</td></tr> <tr><td>23: 9.5</td><td>↓</td></tr> <tr><td>24: 9.6</td><td>←</td></tr> <tr><td>25: 9.5</td><td>→</td></tr> <tr><td>26: *10.9</td><td>↑</td></tr> <tr><td>27: 10.0</td><td>↗</td></tr> <tr><td>28: 9.1</td><td>↑</td></tr> <tr><td>29: *10.5</td><td>←</td></tr> <tr><td>30: 9.5</td><td>↓</td></tr> <tr><td colspan="2"><b>Serie</b> 98.7</td></tr> <tr><td colspan="2"><b>Total</b> 302.2</td></tr> </table>	21: 9.5	↗	22: *10.6	↓	23: 9.5	↓	24: 9.6	←	25: 9.5	→	26: *10.9	↑	27: 10.0	↗	28: 9.1	↑	29: *10.5	←	30: 9.5	↓	<b>Serie</b> 98.7		<b>Total</b> 302.2		<b>60 Skott</b> 	<table border="1" style="width:100%; border-collapse: collapse;"> <tr><td>31: 9.8</td><td>→</td></tr> <tr><td>32: 9.4</td><td>→</td></tr> <tr><td>33: 10.0</td><td>↗</td></tr> <tr><td>34: 9.2</td><td>↗</td></tr> <tr><td>35: *10.2</td><td>↗</td></tr> <tr><td>36: 10.0</td><td>→</td></tr> <tr><td>37: 10.1</td><td>←</td></tr> <tr><td>38: 10.0</td><td>→</td></tr> <tr><td>39: *10.2</td><td>↗</td></tr> <tr><td>40: 10.0</td><td>↓</td></tr> <tr><td colspan="2"><b>Serie</b> 98.9</td></tr> <tr><td colspan="2"><b>Total</b> 401.1</td></tr> </table>	31: 9.8	→	32: 9.4	→	33: 10.0	↗	34: 9.2	↗	35: *10.2	↗	36: 10.0	→	37: 10.1	←	38: 10.0	→	39: *10.2	↗	40: 10.0	↓	<b>Serie</b> 98.9		<b>Total</b> 401.1	
21: 9.5	↗																																																		
22: *10.6	↓																																																		
23: 9.5	↓																																																		
24: 9.6	←																																																		
25: 9.5	→																																																		
26: *10.9	↑																																																		
27: 10.0	↗																																																		
28: 9.1	↑																																																		
29: *10.5	←																																																		
30: 9.5	↓																																																		
<b>Serie</b> 98.7																																																			
<b>Total</b> 302.2																																																			
31: 9.8	→																																																		
32: 9.4	→																																																		
33: 10.0	↗																																																		
34: 9.2	↗																																																		
35: *10.2	↗																																																		
36: 10.0	→																																																		
37: 10.1	←																																																		
38: 10.0	→																																																		
39: *10.2	↗																																																		
40: 10.0	↓																																																		
<b>Serie</b> 98.9																																																			
<b>Total</b> 401.1																																																			
<b>60 Skott</b> 	<table border="1" style="width:100%; border-collapse: collapse;"> <tr><td>41: *10.7</td><td>↗</td></tr> <tr><td>42: *10.3</td><td>→</td></tr> <tr><td>43: *10.7</td><td>↗</td></tr> <tr><td>44: 9.5</td><td>↓</td></tr> <tr><td>45: 9.5</td><td>←</td></tr> <tr><td>46: *10.6</td><td>→</td></tr> <tr><td>47: 8.8</td><td>→</td></tr> <tr><td>48: 9.3</td><td>↓</td></tr> <tr><td>49: 9.5</td><td>↓</td></tr> <tr><td>50: *10.3</td><td>↑</td></tr> <tr><td colspan="2"><b>Serie</b> 99.2</td></tr> <tr><td colspan="2"><b>Total</b> 500.3</td></tr> </table>	41: *10.7	↗	42: *10.3	→	43: *10.7	↗	44: 9.5	↓	45: 9.5	←	46: *10.6	→	47: 8.8	→	48: 9.3	↓	49: 9.5	↓	50: *10.3	↑	<b>Serie</b> 99.2		<b>Total</b> 500.3		<b>60 Skott</b> 	<table border="1" style="width:100%; border-collapse: collapse;"> <tr><td>51: 9.8</td><td>↓</td></tr> <tr><td>52: 9.9</td><td>→</td></tr> <tr><td>53: 9.3</td><td>←</td></tr> <tr><td>54: 9.3</td><td>↓</td></tr> <tr><td>55: 9.3</td><td>↓</td></tr> <tr><td>56: 9.9</td><td>↗</td></tr> <tr><td>57: *10.7</td><td>↓</td></tr> <tr><td>58: 9.9</td><td>←</td></tr> <tr><td>59: *10.7</td><td>←</td></tr> <tr><td>60: 9.8</td><td>←</td></tr> <tr><td colspan="2"><b>Serie</b> 98.6</td></tr> <tr><td colspan="2"><b>Total</b> 598.9</td></tr> </table>	51: 9.8	↓	52: 9.9	→	53: 9.3	←	54: 9.3	↓	55: 9.3	↓	56: 9.9	↗	57: *10.7	↓	58: 9.9	←	59: *10.7	←	60: 9.8	←	<b>Serie</b> 98.6		<b>Total</b> 598.9	
41: *10.7	↗																																																		
42: *10.3	→																																																		
43: *10.7	↗																																																		
44: 9.5	↓																																																		
45: 9.5	←																																																		
46: *10.6	→																																																		
47: 8.8	→																																																		
48: 9.3	↓																																																		
49: 9.5	↓																																																		
50: *10.3	↑																																																		
<b>Serie</b> 99.2																																																			
<b>Total</b> 500.3																																																			
51: 9.8	↓																																																		
52: 9.9	→																																																		
53: 9.3	←																																																		
54: 9.3	↓																																																		
55: 9.3	↓																																																		
56: 9.9	↗																																																		
57: *10.7	↓																																																		
58: 9.9	←																																																		
59: *10.7	←																																																		
60: 9.8	←																																																		
<b>Serie</b> 98.6																																																			
<b>Total</b> 598.9																																																			

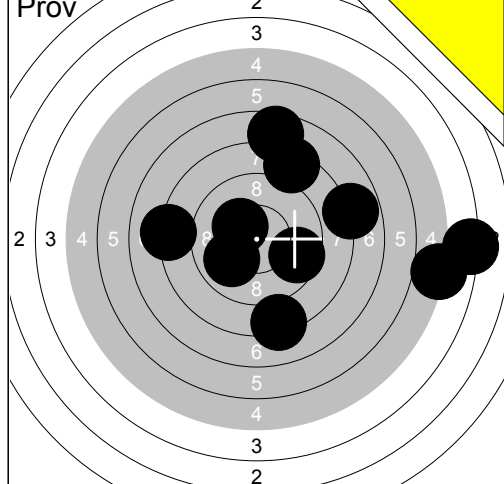

1:	9.9	↙
2:	8.3	↗
3:	7.8	→
4:	8.2	↓
5:	7.5	↑
6:	8.1	←
7:	9.6	→
8:	5.0	→
9:	*10.3	↗
10:	4.1	→

Serie	78.8
Total	0.0

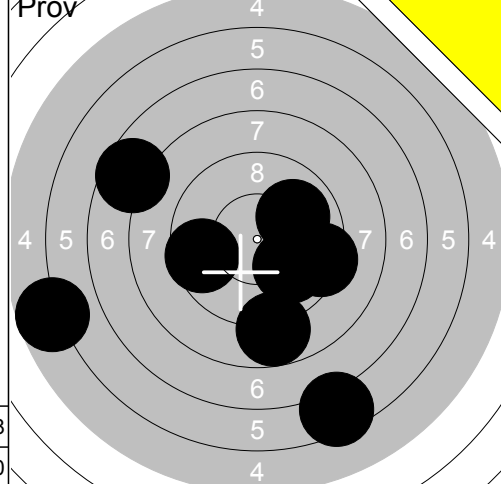

11:	6.4	↘
12:	9.3	→
13:	8.7	↓
14:	7.6	↖
15:	9.9	↗
16:	9.6	←
17:	9.9	↘
18:	5.7	←

Serie	67.1
Total	0.0

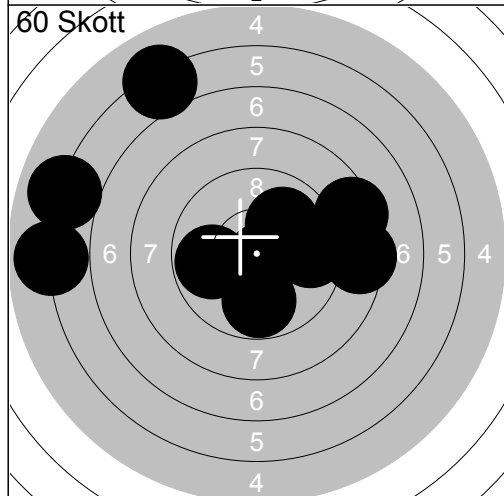

1:	8.4	→
2:	9.6	→
3:	9.8	↓
4:	8.4	→
5:	*10.7	↘
6:	9.8	←
7:	5.9	←
8:	6.0	←
9:	10.0	↗
10:	6.1	↗

Serie	84.7
Total	84.7

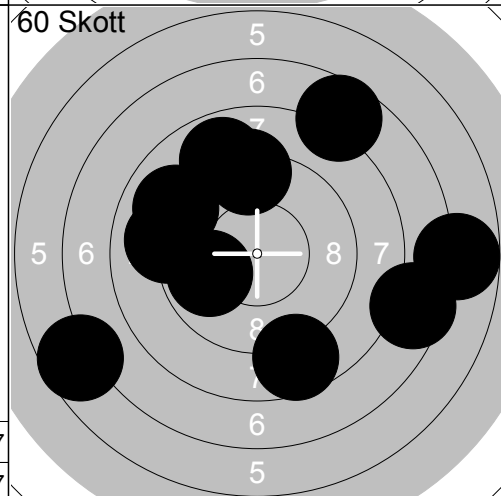

11:	6.8	→
12:	8.6	↓
13:	7.6	↗
14:	9.0	↖
15:	9.9	←
16:	9.2	↑
17:	8.9	↗
18:	7.5	→
19:	6.6	↙
20:	9.0	←

Serie	83.1
Total	167.8

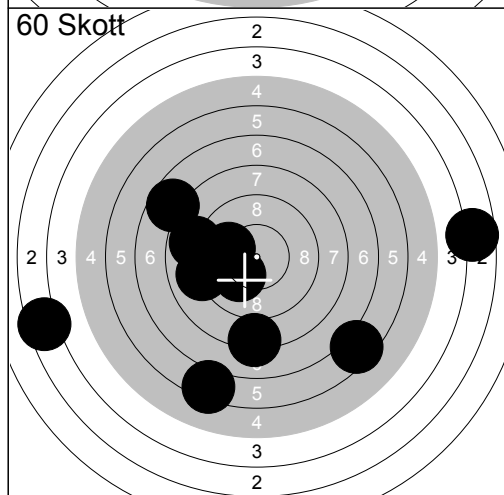

21:	3.4	←
22:	8.1	↓
23:	3.6	→
24:	9.0	←
25:	6.4	↘
26:	8.8	←
27:	7.6	↖
28:	6.3	↓
29:	10.0	←
30:	10.1	↘

Serie	73.3
Total	241.1

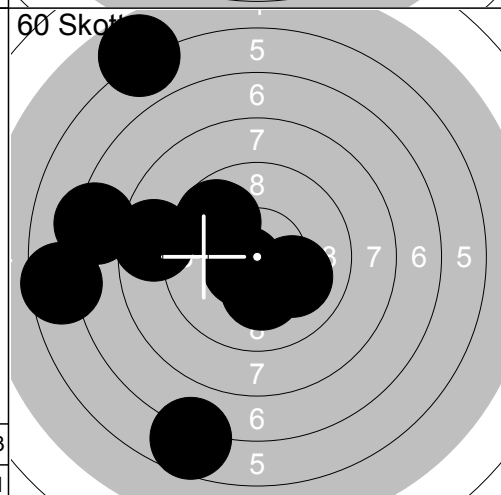

31:	6.6	←
32:	*10.2	↓
33:	6.6	↘
34:	8.6	←
35:	5.8	↗
36:	9.8	↗
37:	10.1	↘
38:	9.7	↗
39:	*10.6	↙
40:	7.3	←

Serie	85.3
Total	326.4

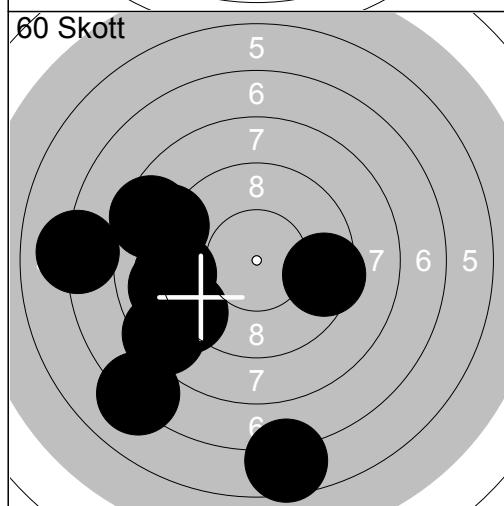

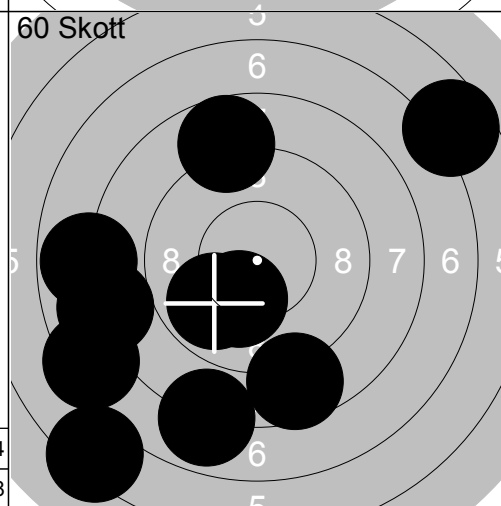

41:	9.2	←
42:	7.1	↙
43:	7.1	←
44:	9.0	←
45:	8.5	↖
46:	6.6	↓
47:	8.4	←
48:	9.5	→
49:	8.9	←
50:	9.1	↙

Serie	83.4
Total	409.8

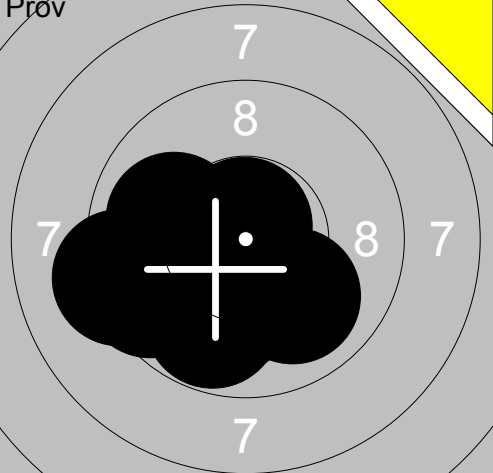
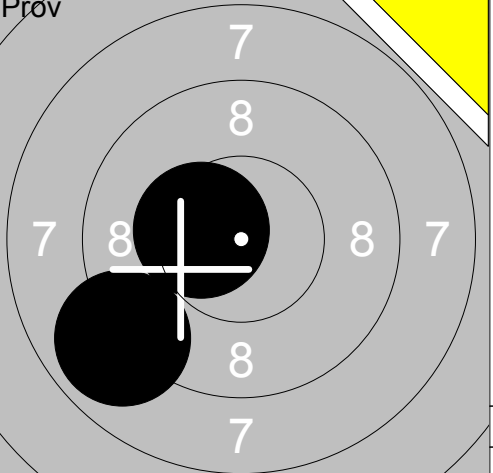
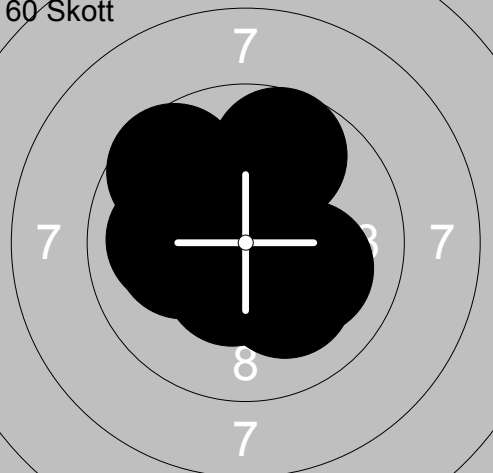
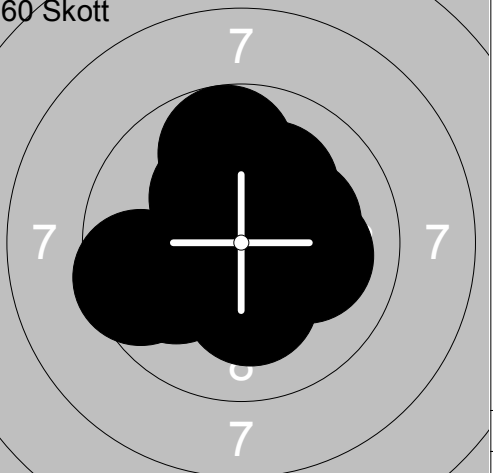

51:	6.6	↗
52:	9.9	↙
53:	7.8	←
54:	*10.2	↓
55:	6.2	↙
56:	7.9	↓
57:	8.7	↑
58:	8.0	←
59:	7.3	↙
60:	8.6	↓

Serie	81.2
Total	491.0

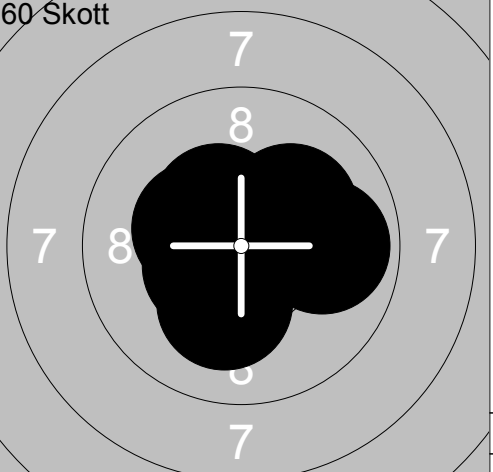
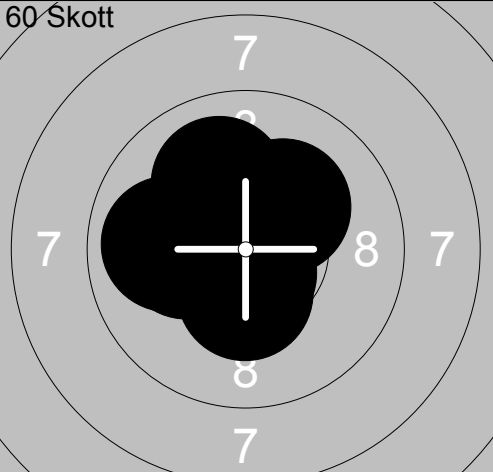
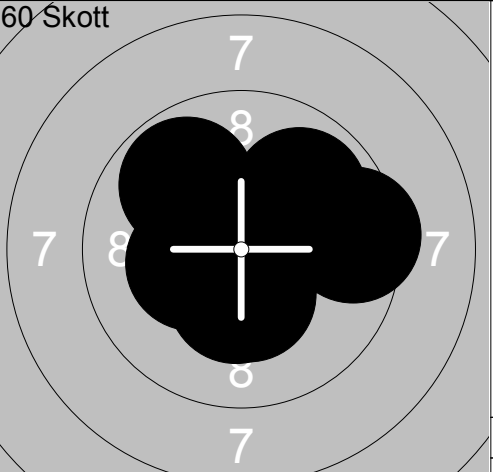
Pröv	Pröv	
		11: 8.9 ↙ 12: *10.4 ←
1: 9.8 ↓ 2: 9.5 ← 3: 9.2 ← 4: 10.0 ↓ 5: *10.8 ↑ 6: 10.0 ← 7: 9.5 ← 8: 10.0 ↓ 9: *10.7 ← 10: *10.5 ←		Serie 100.0 Total 0.0
60 Skott 	60 Skott 	11: 10.1 → 12: *10.2 ↓ 13: 9.5 ← 14: *10.4 → 15: *10.8 → 16: *10.3 ↗ 17: *10.2 → 18: 10.0 ← 19: 10.1 ↗ 20: 9.8 ↑
1: 9.6 ↗ 2: 10.0 ← 3: *10.4 ↓ 4: 10.1 ← 5: 10.1 → 6: *10.6 ← 7: 10.1 ↓ 8: *10.5 ← 9: 9.9 ↗ 10: 9.7 ↑		Serie 101.0 Total 101.0
60 Skott 	60 Skott 	31: *10.5 ↗ 32: *10.5 ← 33: *10.7 ← 34: *10.4 ↗ 35: *10.2 ↓ 36: *10.4 ↗ 37: *10.6 ← 38: *10.4 ← 39: *10.2 ↗ 40: 9.9 →
21: 9.9 → 22: *10.4 → 23: *10.9 → 24: *10.2 ← 25: *10.5 ↓ 26: *10.6 → 27: 10.1 → 28: *10.6 ↑ 29: *10.2 ↓ 30: *10.7 ←		Serie 104.1 Total 306.5
60 Skott 	60 Skott 	51: *10.4 ↓ 52: *10.3 ↓ 53: *10.8 ↗ 54: 9.8 ↗ 55: *10.6 ↓ 56: *10.6 ↗ 57: *10.8 ↗ 58: *10.3 ← 59: 9.9 ↗ 60: 9.5 →
41: *10.8 ↓ 42: *10.8 ↓ 43: 10.0 ↗ 44: *10.4 ↓ 45: 9.9 ← 46: *10.2 ← 47: *10.4 ↗ 48: *10.6 ↓ 49: *10.4 ↗ 50: *10.2 ↗		Serie 103.7 Total 514.0

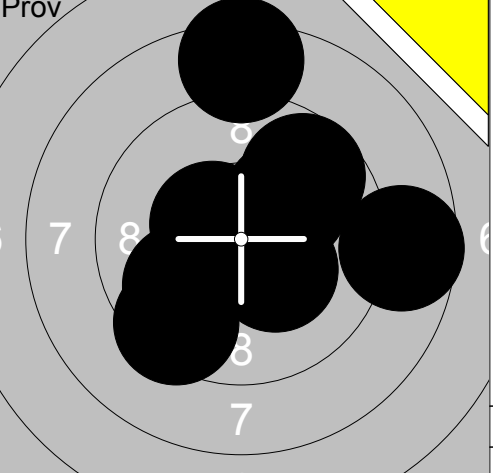
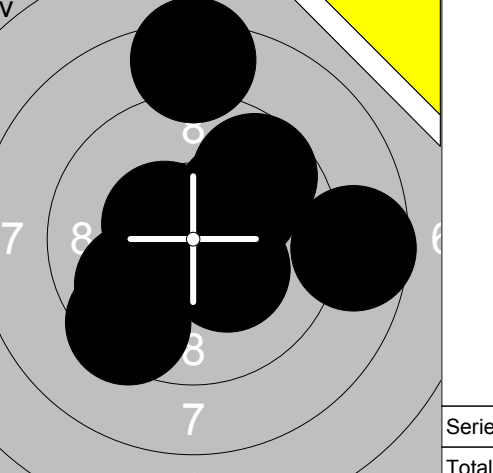
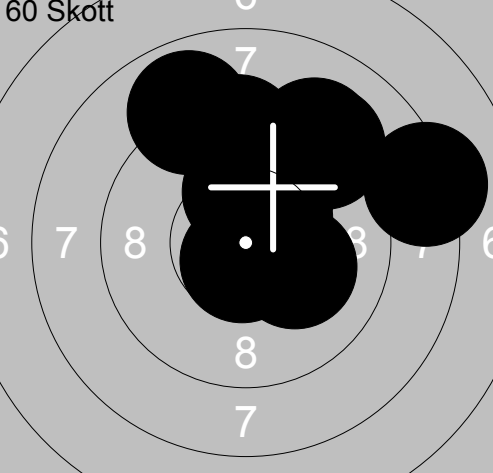
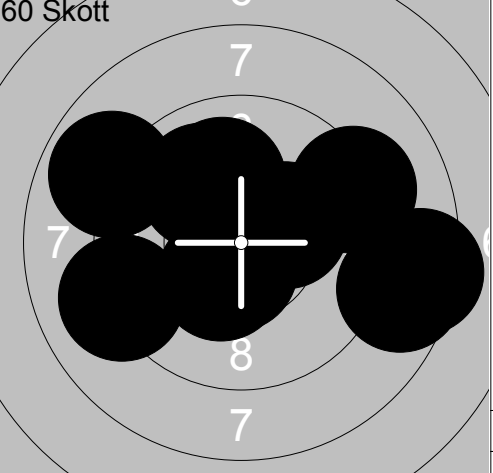
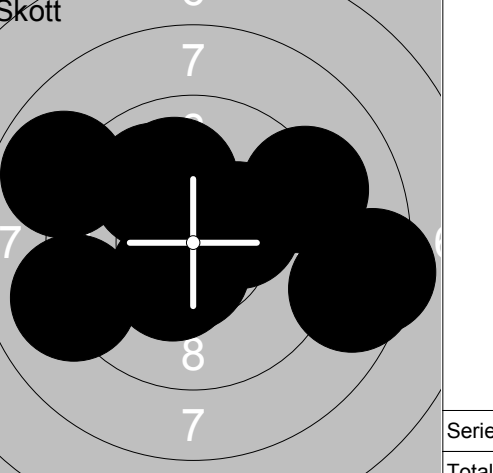
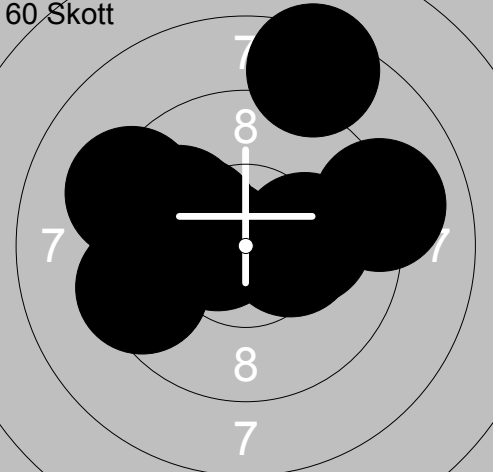
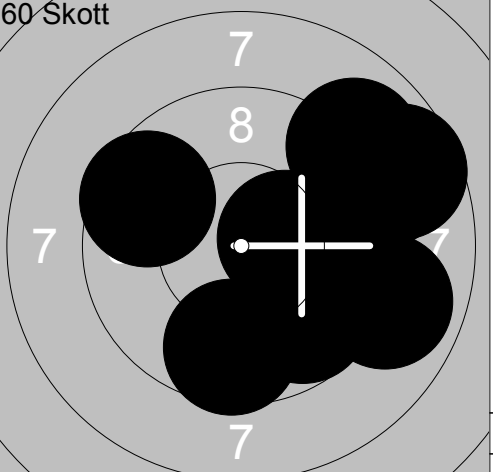
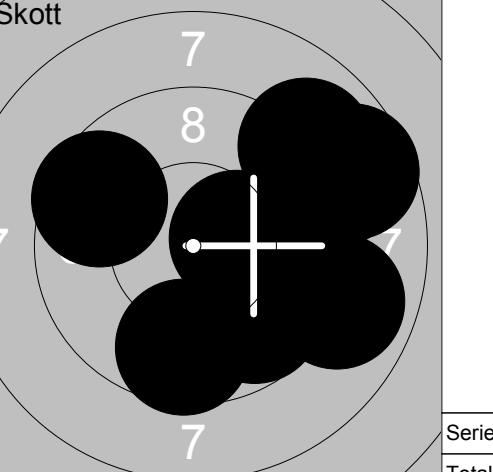
Pröv	Pröv	Pröv																																																																								
																																																																										
<table border="1" style="width:100%; border-collapse: collapse;"> <tr><td>1: 9.5</td><td style="text-align:right;">↓</td></tr> <tr><td>2: 8.8</td><td style="text-align:right;">↗</td></tr> <tr><td>3: *10.8</td><td style="text-align:right;">→</td></tr> <tr><td>4: 9.0</td><td style="text-align:right;">↖</td></tr> <tr><td>5: 8.8</td><td style="text-align:right;">↗</td></tr> <tr><td>6: 9.7</td><td style="text-align:right;">↓</td></tr> <tr><td>7: 8.7</td><td style="text-align:right;">↑</td></tr> <tr><td>8: 9.3</td><td style="text-align:right;">↖</td></tr> <tr><td>9: 9.2</td><td style="text-align:right;">↑</td></tr> <tr><td>10: 9.2</td><td style="text-align:right;">↗</td></tr> <tr><td colspan="2"><b>Serie</b> 93.0</td></tr> <tr><td colspan="2"><b>Total</b> 0.0</td></tr> </table>	1: 9.5	↓	2: 8.8	↗	3: *10.8	→	4: 9.0	↖	5: 8.8	↗	6: 9.7	↓	7: 8.7	↑	8: 9.3	↖	9: 9.2	↑	10: 9.2	↗	<b>Serie</b> 93.0		<b>Total</b> 0.0		<table border="1" style="width:100%; border-collapse: collapse;"> <tr><td>11: 8.4</td><td style="text-align:right;">↑</td></tr> <tr><td>12: *10.8</td><td style="text-align:right;">←</td></tr> <tr><td>13: 8.6</td><td style="text-align:right;">→</td></tr> <tr><td>14: *10.5</td><td style="text-align:right;">→</td></tr> <tr><td>15: 9.9</td><td style="text-align:right;">↙</td></tr> <tr><td>16: 9.4</td><td style="text-align:right;">↙</td></tr> <tr><td>17: *10.3</td><td style="text-align:right;">↘</td></tr> <tr><td>18: *10.5</td><td style="text-align:right;">↖</td></tr> <tr><td>19: 9.7</td><td style="text-align:right;">↗</td></tr> <tr><td>20: 10.1</td><td style="text-align:right;">↗</td></tr> <tr><td colspan="2"><b>Serie</b> 98.2</td></tr> <tr><td colspan="2"><b>Total</b> 0.0</td></tr> </table>	11: 8.4	↑	12: *10.8	←	13: 8.6	→	14: *10.5	→	15: 9.9	↙	16: 9.4	↙	17: *10.3	↘	18: *10.5	↖	19: 9.7	↗	20: 10.1	↗	<b>Serie</b> 98.2		<b>Total</b> 0.0		<table border="1" style="width:100%; border-collapse: collapse;"> <tr><td>21: 9.5</td><td style="text-align:right;">↖</td></tr> <tr><td>22: *10.3</td><td style="text-align:right;">→</td></tr> <tr><td>23: 8.4</td><td style="text-align:right;">↑</td></tr> <tr><td>24: *10.2</td><td style="text-align:right;">↖</td></tr> <tr><td>25: *10.6</td><td style="text-align:right;">←</td></tr> <tr><td>26: 9.2</td><td style="text-align:right;">↖</td></tr> <tr><td>27: 9.1</td><td style="text-align:right;">→</td></tr> <tr><td>28: 9.4</td><td style="text-align:right;">↖</td></tr> <tr><td>29: *10.2</td><td style="text-align:right;">→</td></tr> <tr><td>30: 9.9</td><td style="text-align:right;">↖</td></tr> <tr><td colspan="2"><b>Serie</b> 96.8</td></tr> <tr><td colspan="2"><b>Total</b> 288.8</td></tr> </table>	21: 9.5	↖	22: *10.3	→	23: 8.4	↑	24: *10.2	↖	25: *10.6	←	26: 9.2	↖	27: 9.1	→	28: 9.4	↖	29: *10.2	→	30: 9.9	↖	<b>Serie</b> 96.8		<b>Total</b> 288.8	
1: 9.5	↓																																																																									
2: 8.8	↗																																																																									
3: *10.8	→																																																																									
4: 9.0	↖																																																																									
5: 8.8	↗																																																																									
6: 9.7	↓																																																																									
7: 8.7	↑																																																																									
8: 9.3	↖																																																																									
9: 9.2	↑																																																																									
10: 9.2	↗																																																																									
<b>Serie</b> 93.0																																																																										
<b>Total</b> 0.0																																																																										
11: 8.4	↑																																																																									
12: *10.8	←																																																																									
13: 8.6	→																																																																									
14: *10.5	→																																																																									
15: 9.9	↙																																																																									
16: 9.4	↙																																																																									
17: *10.3	↘																																																																									
18: *10.5	↖																																																																									
19: 9.7	↗																																																																									
20: 10.1	↗																																																																									
<b>Serie</b> 98.2																																																																										
<b>Total</b> 0.0																																																																										
21: 9.5	↖																																																																									
22: *10.3	→																																																																									
23: 8.4	↑																																																																									
24: *10.2	↖																																																																									
25: *10.6	←																																																																									
26: 9.2	↖																																																																									
27: 9.1	→																																																																									
28: 9.4	↖																																																																									
29: *10.2	→																																																																									
30: 9.9	↖																																																																									
<b>Serie</b> 96.8																																																																										
<b>Total</b> 288.8																																																																										
																																																																										
<table border="1" style="width:100%; border-collapse: collapse;"> <tr><td>1: 8.2</td><td style="text-align:right;">→</td></tr> <tr><td>2: 8.9</td><td style="text-align:right;">↑</td></tr> <tr><td>3: 9.2</td><td style="text-align:right;">↗</td></tr> <tr><td>4: 9.4</td><td style="text-align:right;">↑</td></tr> <tr><td>5: *10.2</td><td style="text-align:right;">↘</td></tr> <tr><td>6: *10.7</td><td style="text-align:right;">↓</td></tr> <tr><td>7: 9.2</td><td style="text-align:right;">↗</td></tr> <tr><td>8: 10.1</td><td style="text-align:right;">↗</td></tr> <tr><td>9: *10.2</td><td style="text-align:right;">↑</td></tr> <tr><td>10: *10.4</td><td style="text-align:right;">↗</td></tr> <tr><td colspan="2"><b>Serie</b> 96.5</td></tr> <tr><td colspan="2"><b>Total</b> 96.5</td></tr> </table>	1: 8.2	→	2: 8.9	↑	3: 9.2	↗	4: 9.4	↑	5: *10.2	↘	6: *10.7	↓	7: 9.2	↗	8: 10.1	↗	9: *10.2	↑	10: *10.4	↗	<b>Serie</b> 96.5		<b>Total</b> 96.5		<table border="1" style="width:100%; border-collapse: collapse;"> <tr><td>11: 10.0</td><td style="text-align:right;">↑</td></tr> <tr><td>12: 8.4</td><td style="text-align:right;">→</td></tr> <tr><td>13: *10.6</td><td style="text-align:right;">↓</td></tr> <tr><td>14: 9.2</td><td style="text-align:right;">↗</td></tr> <tr><td>15: 9.1</td><td style="text-align:right;">↖</td></tr> <tr><td>16: 8.6</td><td style="text-align:right;">→</td></tr> <tr><td>17: *10.4</td><td style="text-align:right;">↓</td></tr> <tr><td>18: 8.9</td><td style="text-align:right;">↖</td></tr> <tr><td>19: 10.0</td><td style="text-align:right;">↑</td></tr> <tr><td>20: *10.3</td><td style="text-align:right;">↗</td></tr> <tr><td colspan="2"><b>Serie</b> 95.5</td></tr> <tr><td colspan="2"><b>Total</b> 192.0</td></tr> </table>	11: 10.0	↑	12: 8.4	→	13: *10.6	↓	14: 9.2	↗	15: 9.1	↖	16: 8.6	→	17: *10.4	↓	18: 8.9	↖	19: 10.0	↑	20: *10.3	↗	<b>Serie</b> 95.5		<b>Total</b> 192.0		<table border="1" style="width:100%; border-collapse: collapse;"> <tr><td>31: *10.4</td><td style="text-align:right;">→</td></tr> <tr><td>32: 8.6</td><td style="text-align:right;">↗</td></tr> <tr><td>33: 9.6</td><td style="text-align:right;">↖</td></tr> <tr><td>34: 9.7</td><td style="text-align:right;">↘</td></tr> <tr><td>35: 9.6</td><td style="text-align:right;">↓</td></tr> <tr><td>36: 10.1</td><td style="text-align:right;">↘</td></tr> <tr><td>37: 8.9</td><td style="text-align:right;">↗</td></tr> <tr><td>38: 9.0</td><td style="text-align:right;">↗</td></tr> <tr><td>39: 9.6</td><td style="text-align:right;">→</td></tr> <tr><td>40: 8.9</td><td style="text-align:right;">↘</td></tr> <tr><td colspan="2"><b>Serie</b> 94.4</td></tr> <tr><td colspan="2"><b>Total</b> 383.2</td></tr> </table>	31: *10.4	→	32: 8.6	↗	33: 9.6	↖	34: 9.7	↘	35: 9.6	↓	36: 10.1	↘	37: 8.9	↗	38: 9.0	↗	39: 9.6	→	40: 8.9	↘	<b>Serie</b> 94.4		<b>Total</b> 383.2	
1: 8.2	→																																																																									
2: 8.9	↑																																																																									
3: 9.2	↗																																																																									
4: 9.4	↑																																																																									
5: *10.2	↘																																																																									
6: *10.7	↓																																																																									
7: 9.2	↗																																																																									
8: 10.1	↗																																																																									
9: *10.2	↑																																																																									
10: *10.4	↗																																																																									
<b>Serie</b> 96.5																																																																										
<b>Total</b> 96.5																																																																										
11: 10.0	↑																																																																									
12: 8.4	→																																																																									
13: *10.6	↓																																																																									
14: 9.2	↗																																																																									
15: 9.1	↖																																																																									
16: 8.6	→																																																																									
17: *10.4	↓																																																																									
18: 8.9	↖																																																																									
19: 10.0	↑																																																																									
20: *10.3	↗																																																																									
<b>Serie</b> 95.5																																																																										
<b>Total</b> 192.0																																																																										
31: *10.4	→																																																																									
32: 8.6	↗																																																																									
33: 9.6	↖																																																																									
34: 9.7	↘																																																																									
35: 9.6	↓																																																																									
36: 10.1	↘																																																																									
37: 8.9	↗																																																																									
38: 9.0	↗																																																																									
39: 9.6	→																																																																									
40: 8.9	↘																																																																									
<b>Serie</b> 94.4																																																																										
<b>Total</b> 383.2																																																																										
																																																																										
<table border="1" style="width:100%; border-collapse: collapse;"> <tr><td>41: 9.8</td><td style="text-align:right;">→</td></tr> <tr><td>42: 9.2</td><td style="text-align:right;">↙</td></tr> <tr><td>43: 8.6</td><td style="text-align:right;">↖</td></tr> <tr><td>44: 9.5</td><td style="text-align:right;">↗</td></tr> <tr><td>45: 9.9</td><td style="text-align:right;">↑</td></tr> <tr><td>46: 10.0</td><td style="text-align:right;">↘</td></tr> <tr><td>47: *10.2</td><td style="text-align:right;">↗</td></tr> <tr><td>48: 8.9</td><td style="text-align:right;">↘</td></tr> <tr><td>49: 8.2</td><td style="text-align:right;">↘</td></tr> <tr><td>50: *10.4</td><td style="text-align:right;">↓</td></tr> <tr><td colspan="2"><b>Serie</b> 94.7</td></tr> <tr><td colspan="2"><b>Total</b> 477.9</td></tr> </table>	41: 9.8	→	42: 9.2	↙	43: 8.6	↖	44: 9.5	↗	45: 9.9	↑	46: 10.0	↘	47: *10.2	↗	48: 8.9	↘	49: 8.2	↘	50: *10.4	↓	<b>Serie</b> 94.7		<b>Total</b> 477.9		<table border="1" style="width:100%; border-collapse: collapse;"> <tr><td>51: *10.2</td><td style="text-align:right;">↙</td></tr> <tr><td>52: *10.5</td><td style="text-align:right;">←</td></tr> <tr><td>53: *10.2</td><td style="text-align:right;">↗</td></tr> <tr><td>54: 9.1</td><td style="text-align:right;">↘</td></tr> <tr><td>55: 9.6</td><td style="text-align:right;">→</td></tr> <tr><td>56: 9.4</td><td style="text-align:right;">↑</td></tr> <tr><td>57: *10.4</td><td style="text-align:right;">↑</td></tr> <tr><td>58: 8.2</td><td style="text-align:right;">↙</td></tr> <tr><td>59: 9.2</td><td style="text-align:right;">→</td></tr> <tr><td>60: *10.3</td><td style="text-align:right;">↖</td></tr> <tr><td colspan="2"><b>Serie</b> 97.1</td></tr> <tr><td colspan="2"><b>Total</b> 575.0</td></tr> </table>	51: *10.2	↙	52: *10.5	←	53: *10.2	↗	54: 9.1	↘	55: 9.6	→	56: 9.4	↑	57: *10.4	↑	58: 8.2	↙	59: 9.2	→	60: *10.3	↖	<b>Serie</b> 97.1		<b>Total</b> 575.0																										
41: 9.8	→																																																																									
42: 9.2	↙																																																																									
43: 8.6	↖																																																																									
44: 9.5	↗																																																																									
45: 9.9	↑																																																																									
46: 10.0	↘																																																																									
47: *10.2	↗																																																																									
48: 8.9	↘																																																																									
49: 8.2	↘																																																																									
50: *10.4	↓																																																																									
<b>Serie</b> 94.7																																																																										
<b>Total</b> 477.9																																																																										
51: *10.2	↙																																																																									
52: *10.5	←																																																																									
53: *10.2	↗																																																																									
54: 9.1	↘																																																																									
55: 9.6	→																																																																									
56: 9.4	↑																																																																									
57: *10.4	↑																																																																									
58: 8.2	↙																																																																									
59: 9.2	→																																																																									
60: *10.3	↖																																																																									
<b>Serie</b> 97.1																																																																										
<b>Total</b> 575.0																																																																										

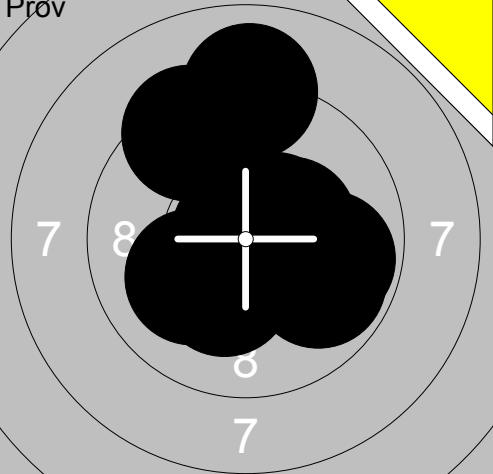
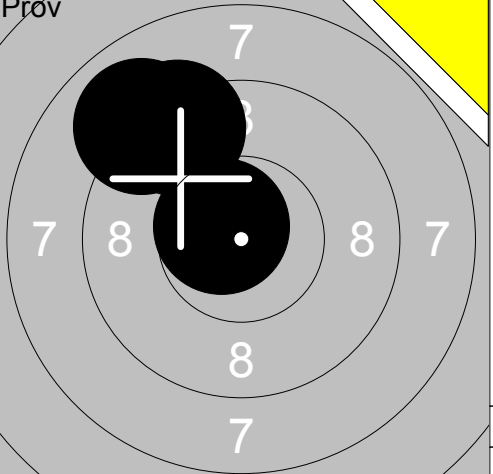
<p>Prøv</p> 	<p>1: *10.5 →</p> <p>2: 10.1 →</p> <p>3: 10.1 ←</p> <p>4: 9.9 →</p> <p>5: *10.4 →</p> <p>6: *10.2 ↓</p> <p>7: *10.8 ↗</p> <p>8: 9.4 ↗</p> <p>9: 9.8 →</p> <p>10: 9.0 ↑</p>	<p>Prøv</p> 	<p>11: 9.0 ↗</p> <p>12: *10.6 ↗</p> <p>13: 9.3 ↗</p>
Serie	100.2	Serie	28.9
Total	0.0	Total	0.0

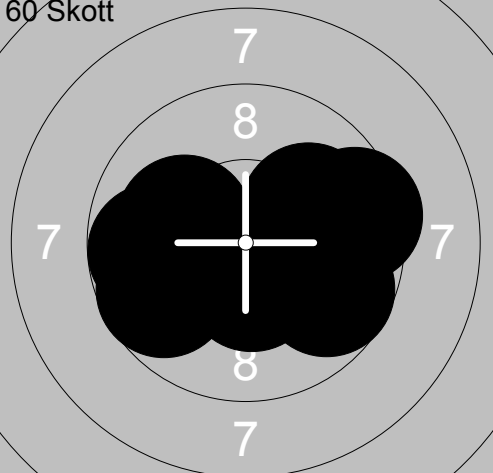
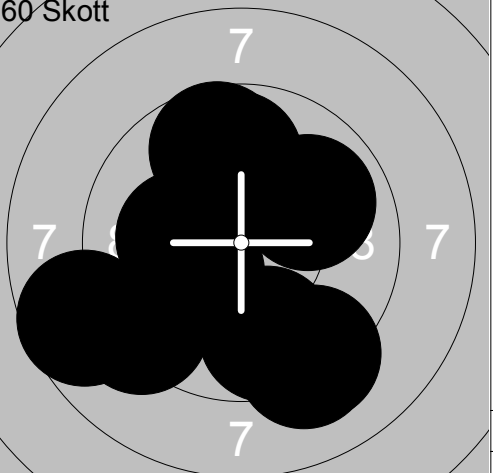
<p>60 Skott</p> 	<p>1: *10.2 →</p> <p>2: 10.0 ↗</p> <p>3: 9.7 →</p> <p>4: *10.4 ↓</p> <p>5: 10.0 ←</p> <p>6: 9.8 ←</p> <p>7: *10.3 →</p> <p>8: 9.5 →</p> <p>9: 9.7 ←</p> <p>10: 10.1 ←</p>	<p>60 Skott</p> 	<p>11: 9.2 ↓</p> <p>12: *10.2 ←</p> <p>13: 9.8 ↑</p> <p>14: 9.2 ←</p> <p>15: 9.7 ↑</p> <p>16: 8.7 ←</p> <p>17: *10.2 ←</p> <p>18: 9.9 ↗</p> <p>19: 9.2 ↓</p> <p>20: 9.7 ↓</p>
Serie	99.7	Serie	95.8
Total	99.7	Total	195.5

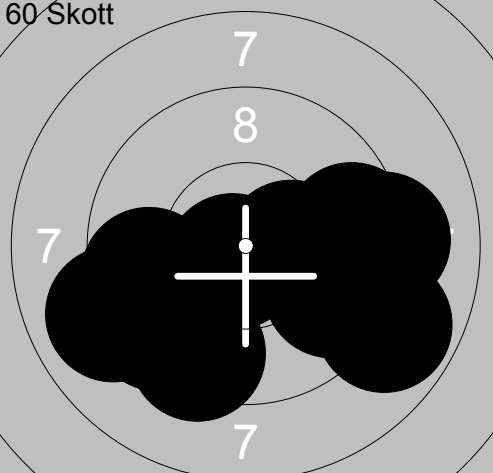
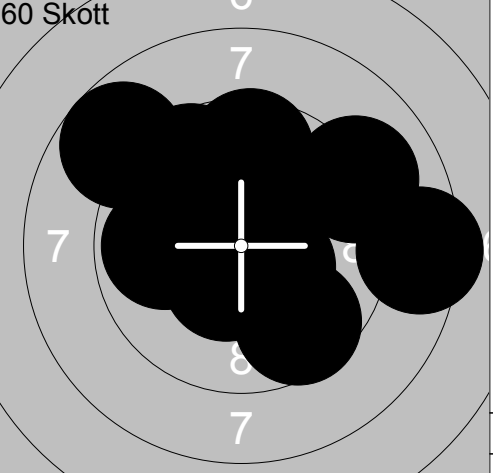
<p>60 Skott</p> 	<p>21: 9.5 →</p> <p>22: *10.3 →</p> <p>23: 9.0 ←</p> <p>24: 9.4 ←</p> <p>25: 9.7 →</p> <p>26: 9.4 ↓</p> <p>27: 9.6 ←</p> <p>28: 8.8 →</p> <p>29: *10.7 ↓</p> <p>30: 9.1 →</p>	<p>60 Skott</p> 	<p>31: 8.7 ↗</p> <p>32: 8.4 →</p> <p>33: *10.4 ↓</p> <p>34: 9.6 ↓</p> <p>35: *10.4 ↓</p> <p>36: 9.6 ↗</p> <p>37: *10.3 ↗</p> <p>38: 9.6 ↑</p> <p>39: 9.1 ↗</p> <p>40: 9.9 ←</p>
Serie	95.5	Serie	96.0
Total	291.0	Total	387.0

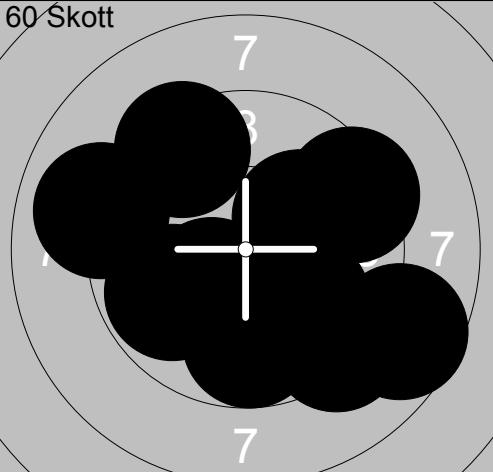
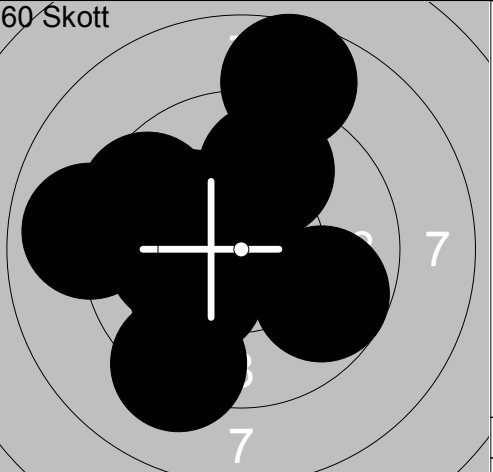
<p>60 Skott</p> 	<p>41: 8.6 →</p> <p>42: 9.8 ←</p> <p>43: *10.3 ↓</p> <p>44: 10.1 ↗</p> <p>45: 9.4 ↗</p> <p>46: 9.2 ↓</p> <p>47: 9.4 ↗</p> <p>48: 9.9 ↓</p> <p>49: 9.7 ↓</p> <p>50: 9.0 ←</p>	<p>60 Skott</p> 	<p>51: 8.9 ←</p> <p>52: *10.2 ↓</p> <p>53: 9.2 ↓</p> <p>54: 9.9 ↑</p> <p>55: 9.6 ←</p> <p>56: 8.7 ↑</p> <p>57: *10.2 ↗</p> <p>58: 10.1 ←</p> <p>59: *10.8 ←</p> <p>60: 9.7 ↓</p>
Serie	95.4	Serie	97.3
Total	482.4	Total	579.7

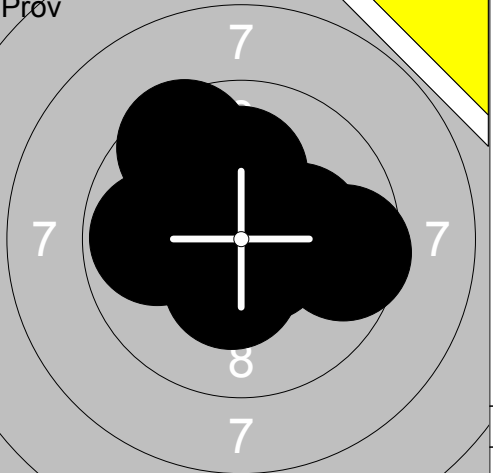

Pröv	Pröv	
		
1: 9.4 → 2: *10.7 ↗ 3: 9.6 → 4: 9.4 ↗ 5: 8.6 ↗ 6: *10.2 ↑ 7: *10.4 → 8: *10.3 ← 9: *10.8 ↘ 10: 9.5 ↘	11: *10.8 ← 12: *10.2 → 13: 9.5 ↗ 14: 9.6 → 15: 10.1 ↑ 16: *10.4 ↓ 17: 9.8 ← 18: *10.6 ↘	
Serie 98.9	Serie 81.0	
Total 0.0	Total 0.0	
60 Skott	60 Skott	
1: 10.1 ↗ 2: *10.4 ↗ 3: 10.1 ← 4: 9.9 ↗ 5: 9.5 ← 6: 9.6 ↑ 7: 9.2 ↗ 8: *10.5 ↗ 9: *10.8 ↘ 10: *10.5 ←	11: 10.0 ← 12: 9.5 → 13: *10.8 ↘ 14: 9.6 ↘ 15: 9.0 ↑ 16: 10.0 → 17: 9.8 ↑ 18: 9.8 → 19: *10.5 ↙ 20: *10.3 ↗	
Serie 100.6	Serie 99.3	
Total 100.6	Total 199.9	
60 Skott	60 Skott	
21: 9.6 ↑ 22: 9.8 ↑ 23: *10.4 ↘ 24: 10.1 ↖ 25: *10.6 ↗ 26: 9.6 ↗ 27: 9.3 ↗ 28: 9.7 ↗ 29: *10.5 ↑ 30: 10.0 ↑	31: *10.2 ↘ 32: 9.7 → 33: *10.7 ↑ 34: *10.3 ← 35: 8.8 → 36: *10.3 → 37: *10.6 ↑ 38: 9.8 ← 39: *10.2 ↖ 40: 9.5 →	
Serie 99.6	Serie 100.1	
Total 299.5	Total 399.6	
60 Skott	60 Skott	
41: 10.1 ↓ 42: 9.2 ↙ 43: *10.7 ↗ 44: 9.9 ↓ 45: 9.8 ← 46: *10.4 ↘ 47: 10.0 ↖ 48: 9.3 → 49: 10.0 ↘ 50: *10.5 ←	51: *10.2 ← 52: 9.7 → 53: 10.1 ↗ 54: 10.1 ← 55: *10.7 ↖ 56: *10.4 → 57: *10.6 ↓ 58: 9.8 → 59: 9.5 ← 60: *10.3 ↘	
Serie 99.9	Serie 101.4	
Total 499.5	Total 600.9	

<p>Pröv</p>	<p>1: *10.7 ↙ 2: 7.7 → 3: 10.1 ↑ 4: *10.3 ↖ 5: 9.1 → 6: 8.7 → 7: *10.3 ↑ 8: *10.7 ↗ 9: 9.5 ← 10: *10.4 ↑</p> <p>Serie 97.5 Total 0.0</p>	<p>Pröv</p>	<p>11: 9.3 → 12: 9.7 ↗ 13: 9.7 ← 14: *10.6 ↓ 15: 9.6 → 16: *10.5 → 17: *10.7 ↓ 18: *10.3 ↑ 19: 10.0 ↑ 20: *10.2 →</p> <p>Serie 100.6 Total 0.0</p>
<p>60 Skott</p>	<p>1: 9.6 ↘ 2: 10.0 ← 3: 9.1 → 4: *10.4 ↑ 5: 8.7 → 6: 9.0 → 7: *10.8 ↓ 8: *10.6 ↗ 9: 10.0 ↑ 10: 9.0 →</p> <p>Serie 97.2 Total 97.2</p>	<p>60 Skott</p>	<p>11: 9.7 → 12: 9.8 ↙ 13: *10.4 → 14: 9.4 ↓ 15: 9.7 ← 16: 10.1 → 17: *10.6 ↓ 18: 8.8 ↖ 19: 9.1 ← 20: *10.7 →</p> <p>Serie 98.3 Total 195.5</p>
<p>60 Skott</p>	<p>21: 10.1 ↘ 22: 9.5 ← 23: 10.0 ↖ 24: 9.8 ↙ 25: *10.2 ↑ 26: 10.1 → 27: 9.1 → 28: *10.3 → 29: 9.0 ↑ 30: 9.4 ↘</p> <p>Serie 97.5 Total 293.0</p>	<p>60 Skott</p>	<p>31: *10.3 ← 32: *10.2 ← 33: *10.3 ↓ 34: 9.0 → 35: *10.7 ↗ 36: 9.9 ↑ 37: 9.4 → 38: 9.1 ↗ 39: 8.9 → 40: *10.3 ↗</p> <p>Serie 98.1 Total 391.1</p>
<p>60 Skott</p>	<p>41: 10.0 → 42: *10.4 → 43: 10.0 → 44: *10.2 ↓ 45: *10.2 ↓ 46: 9.2 ← 47: 9.7 ← 48: 10.1 ↙ 49: *10.2 ↖ 50: 9.9 ↓</p> <p>Serie 99.9 Total 491.0</p>	<p>60 Skott</p>	<p>51: *10.5 ↓ 52: *10.6 ↓ 53: 9.0 ↖ 54: *10.2 ↗ 55: 8.8 ↖ 56: 9.1 ↙ 57: *10.9 ← 58: 9.6 → 59: 9.2 ← 60: *10.5 ↑</p> <p>Serie 98.4 Total 589.4</p>

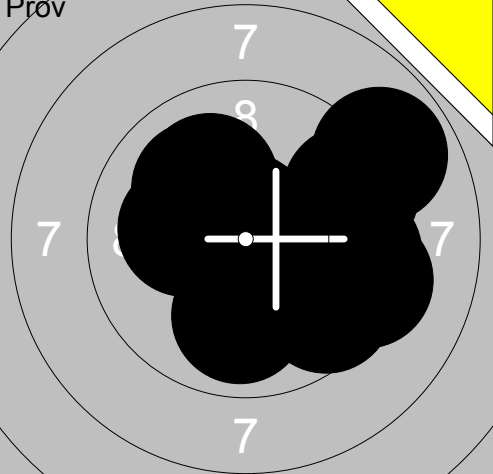
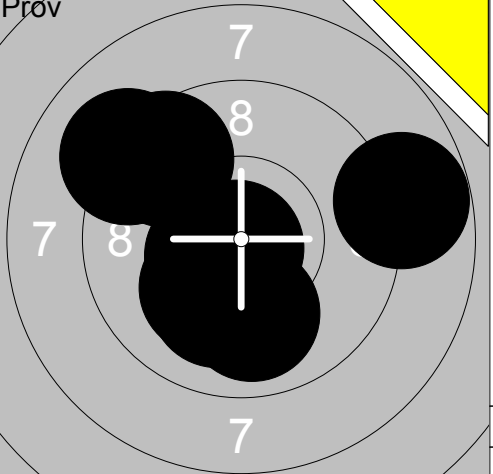
<p>Prøv</p> 	<table border="1" style="width:100%; border-collapse: collapse;"> <tr><td>1:</td><td>10.1</td><td>←</td></tr> <tr><td>2:</td><td>9.3</td><td>→</td></tr> <tr><td>3:</td><td>9.4</td><td>→</td></tr> <tr><td>4:</td><td>9.9</td><td>↓</td></tr> <tr><td>5:</td><td>9.6</td><td>↓</td></tr> <tr><td>6:</td><td>10.1</td><td>↗</td></tr> <tr><td>7:</td><td>9.5</td><td>→</td></tr> <tr><td>8:</td><td>8.9</td><td>↗</td></tr> <tr><td>9:</td><td>*10.7</td><td>↑</td></tr> <tr><td>10:</td><td>10.0</td><td>↗</td></tr> <tr><td colspan="2">Serie</td><td>97.5</td></tr> <tr><td colspan="2">Total</td><td>0.0</td></tr> </table>	1:	10.1	←	2:	9.3	→	3:	9.4	→	4:	9.9	↓	5:	9.6	↓	6:	10.1	↗	7:	9.5	→	8:	8.9	↗	9:	*10.7	↑	10:	10.0	↗	Serie		97.5	Total		0.0	<p>Prøv</p> 	<table border="1" style="width:100%; border-collapse: collapse;"> <tr><td>11:</td><td>9.5</td><td>↖</td></tr> <tr><td>12:</td><td>*10.5</td><td>←</td></tr> <tr><td>13:</td><td>9.1</td><td>↖</td></tr> <tr><td>14:</td><td>*10.2</td><td>↓</td></tr> <tr><td>15:</td><td>8.8</td><td>→</td></tr> <tr><td>16:</td><td>10.1</td><td>↓</td></tr> <tr><td>17:</td><td>*10.8</td><td>↓</td></tr> <tr><td>18:</td><td>10.0</td><td>↓</td></tr> <tr><td colspan="2">Serie</td><td>79.0</td></tr> <tr><td colspan="2">Total</td><td>0.0</td></tr> </table>	11:	9.5	↖	12:	*10.5	←	13:	9.1	↖	14:	*10.2	↓	15:	8.8	→	16:	10.1	↓	17:	*10.8	↓	18:	10.0	↓	Serie		79.0	Total		0.0
1:	10.1	←																																																																			
2:	9.3	→																																																																			
3:	9.4	→																																																																			
4:	9.9	↓																																																																			
5:	9.6	↓																																																																			
6:	10.1	↗																																																																			
7:	9.5	→																																																																			
8:	8.9	↗																																																																			
9:	*10.7	↑																																																																			
10:	10.0	↗																																																																			
Serie		97.5																																																																			
Total		0.0																																																																			
11:	9.5	↖																																																																			
12:	*10.5	←																																																																			
13:	9.1	↖																																																																			
14:	*10.2	↓																																																																			
15:	8.8	→																																																																			
16:	10.1	↓																																																																			
17:	*10.8	↓																																																																			
18:	10.0	↓																																																																			
Serie		79.0																																																																			
Total		0.0																																																																			

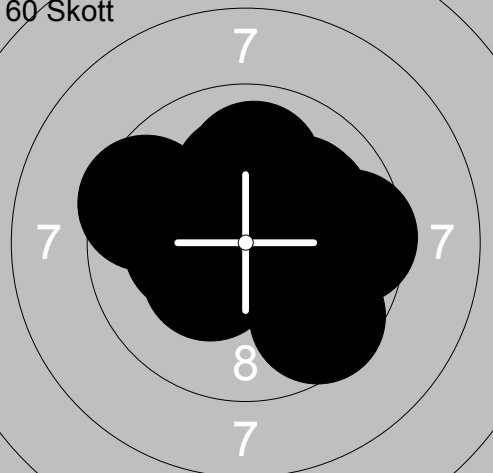
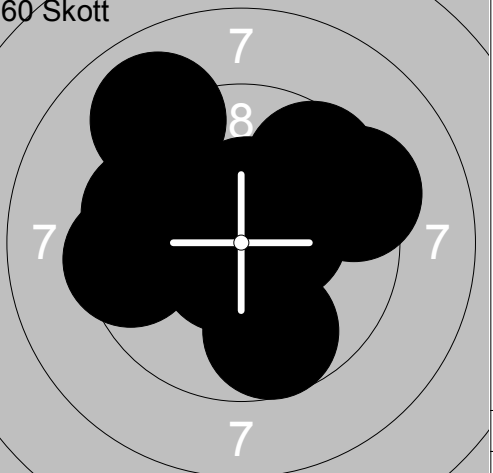
<p>60 Skott</p> 	<table border="1" style="width:100%; border-collapse: collapse;"> <tr><td>1:</td><td>9.6</td><td>→</td></tr> <tr><td>2:</td><td>9.6</td><td>↓</td></tr> <tr><td>3:</td><td>10.0</td><td>↑</td></tr> <tr><td>4:</td><td>*10.2</td><td>↑</td></tr> <tr><td>5:</td><td>*10.2</td><td>←</td></tr> <tr><td>6:</td><td>*10.3</td><td>↖</td></tr> <tr><td>7:</td><td>10.1</td><td>↗</td></tr> <tr><td>8:</td><td>9.5</td><td>↖</td></tr> <tr><td>9:</td><td>*10.3</td><td>↙</td></tr> <tr><td>10:</td><td>10.1</td><td>↗</td></tr> <tr><td colspan="2">Serie</td><td>99.9</td></tr> <tr><td colspan="2">Total</td><td>99.9</td></tr> </table>	1:	9.6	→	2:	9.6	↓	3:	10.0	↑	4:	*10.2	↑	5:	*10.2	←	6:	*10.3	↖	7:	10.1	↗	8:	9.5	↖	9:	*10.3	↙	10:	10.1	↗	Serie		99.9	Total		99.9	<p>60 Skott</p> 	<table border="1" style="width:100%; border-collapse: collapse;"> <tr><td>11:</td><td>*10.4</td><td>→</td></tr> <tr><td>12:</td><td>*10.6</td><td>↗</td></tr> <tr><td>13:</td><td>9.7</td><td>↓</td></tr> <tr><td>14:</td><td>*10.4</td><td>↑</td></tr> <tr><td>15:</td><td>*10.6</td><td>↓</td></tr> <tr><td>16:</td><td>9.3</td><td>↗</td></tr> <tr><td>17:</td><td>9.5</td><td>←</td></tr> <tr><td>18:</td><td>9.0</td><td>↗</td></tr> <tr><td>19:</td><td>9.7</td><td>←</td></tr> <tr><td>20:</td><td>9.6</td><td>↗</td></tr> <tr><td colspan="2">Serie</td><td>98.8</td></tr> <tr><td colspan="2">Total</td><td>198.7</td></tr> </table>	11:	*10.4	→	12:	*10.6	↗	13:	9.7	↓	14:	*10.4	↑	15:	*10.6	↓	16:	9.3	↗	17:	9.5	←	18:	9.0	↗	19:	9.7	←	20:	9.6	↗	Serie		98.8	Total		198.7
1:	9.6	→																																																																									
2:	9.6	↓																																																																									
3:	10.0	↑																																																																									
4:	*10.2	↑																																																																									
5:	*10.2	←																																																																									
6:	*10.3	↖																																																																									
7:	10.1	↗																																																																									
8:	9.5	↖																																																																									
9:	*10.3	↙																																																																									
10:	10.1	↗																																																																									
Serie		99.9																																																																									
Total		99.9																																																																									
11:	*10.4	→																																																																									
12:	*10.6	↗																																																																									
13:	9.7	↓																																																																									
14:	*10.4	↑																																																																									
15:	*10.6	↓																																																																									
16:	9.3	↗																																																																									
17:	9.5	←																																																																									
18:	9.0	↗																																																																									
19:	9.7	←																																																																									
20:	9.6	↗																																																																									
Serie		98.8																																																																									
Total		198.7																																																																									

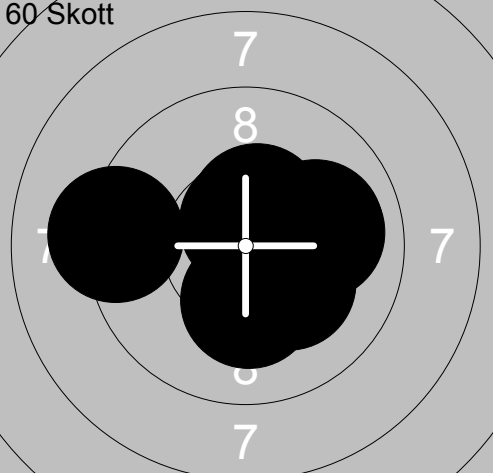
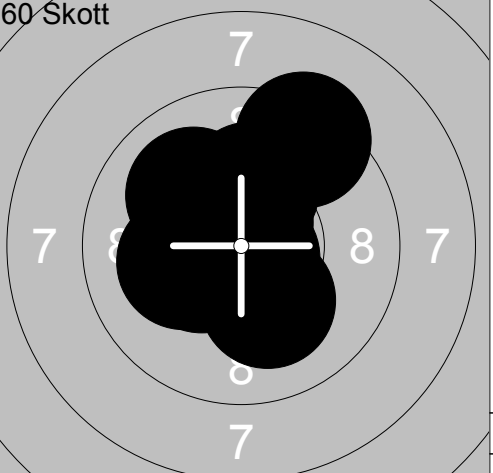
<p>60 Skott</p> 	<table border="1" style="width:100%; border-collapse: collapse;"> <tr><td>21:</td><td>10.0</td><td>→</td></tr> <tr><td>22:</td><td>*10.5</td><td>↑</td></tr> <tr><td>23:</td><td>*10.6</td><td>↑</td></tr> <tr><td>24:</td><td>*10.7</td><td>↑</td></tr> <tr><td>25:</td><td>*10.2</td><td>↓</td></tr> <tr><td>26:</td><td>10.0</td><td>→</td></tr> <tr><td>27:</td><td>*10.6</td><td>→</td></tr> <tr><td>28:</td><td>*10.2</td><td>↓</td></tr> <tr><td>29:</td><td>9.2</td><td>←</td></tr> <tr><td>30:</td><td>*10.7</td><td>↑</td></tr> <tr><td colspan="2">Serie</td><td>102.7</td></tr> <tr><td colspan="2">Total</td><td>301.4</td></tr> </table>	21:	10.0	→	22:	*10.5	↑	23:	*10.6	↑	24:	*10.7	↑	25:	*10.2	↓	26:	10.0	→	27:	*10.6	→	28:	*10.2	↓	29:	9.2	←	30:	*10.7	↑	Serie		102.7	Total		301.4	<p>60 Skott</p> 	<table border="1" style="width:100%; border-collapse: collapse;"> <tr><td>31:</td><td>*10.3</td><td>←</td></tr> <tr><td>32:</td><td>10.1</td><td>↓</td></tr> <tr><td>33:</td><td>10.0</td><td>↗</td></tr> <tr><td>34:</td><td>*10.7</td><td>↓</td></tr> <tr><td>35:</td><td>9.3</td><td>↗</td></tr> <tr><td>36:</td><td>*10.2</td><td>←</td></tr> <tr><td>37:</td><td>*10.2</td><td>↑</td></tr> <tr><td>38:</td><td>*10.6</td><td>↑</td></tr> <tr><td>39:</td><td>*10.4</td><td>←</td></tr> <tr><td>40:</td><td>*10.4</td><td>↖</td></tr> <tr><td colspan="2">Serie</td><td>102.2</td></tr> <tr><td colspan="2">Total</td><td>403.6</td></tr> </table>	31:	*10.3	←	32:	10.1	↓	33:	10.0	↗	34:	*10.7	↓	35:	9.3	↗	36:	*10.2	←	37:	*10.2	↑	38:	*10.6	↑	39:	*10.4	←	40:	*10.4	↖	Serie		102.2	Total		403.6
21:	10.0	→																																																																									
22:	*10.5	↑																																																																									
23:	*10.6	↑																																																																									
24:	*10.7	↑																																																																									
25:	*10.2	↓																																																																									
26:	10.0	→																																																																									
27:	*10.6	→																																																																									
28:	*10.2	↓																																																																									
29:	9.2	←																																																																									
30:	*10.7	↑																																																																									
Serie		102.7																																																																									
Total		301.4																																																																									
31:	*10.3	←																																																																									
32:	10.1	↓																																																																									
33:	10.0	↗																																																																									
34:	*10.7	↓																																																																									
35:	9.3	↗																																																																									
36:	*10.2	←																																																																									
37:	*10.2	↑																																																																									
38:	*10.6	↑																																																																									
39:	*10.4	←																																																																									
40:	*10.4	↖																																																																									
Serie		102.2																																																																									
Total		403.6																																																																									

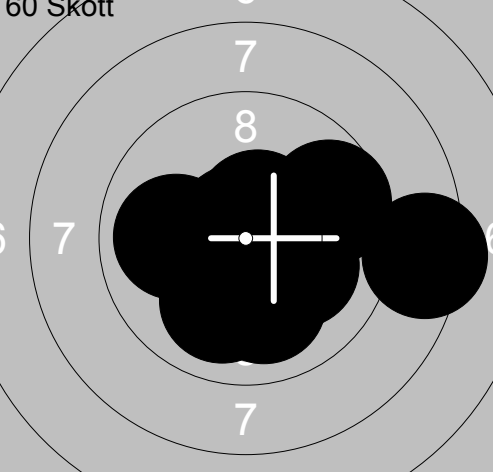
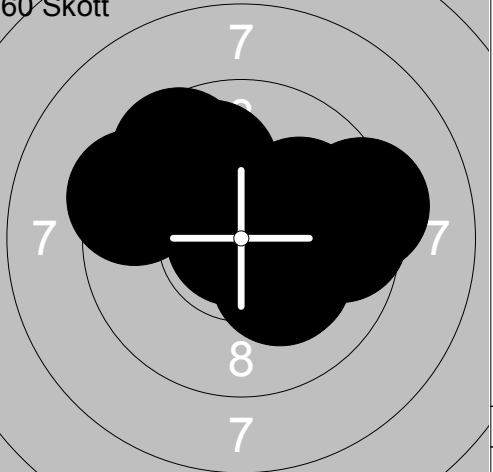
<p>60 Skott</p> 	<table border="1" style="width:100%; border-collapse: collapse;"> <tr><td>41:</td><td>*10.8</td><td>↖</td></tr> <tr><td>42:</td><td>10.0</td><td>↓</td></tr> <tr><td>43:</td><td>9.7</td><td>→</td></tr> <tr><td>44:</td><td>*10.5</td><td>↑</td></tr> <tr><td>45:</td><td>8.4</td><td>→</td></tr> <tr><td>46:</td><td>*10.7</td><td>→</td></tr> <tr><td>47:</td><td>*10.5</td><td>↗</td></tr> <tr><td>48:</td><td>10.1</td><td>↘</td></tr> <tr><td>49:</td><td>10.0</td><td>↓</td></tr> <tr><td>50:</td><td>9.9</td><td>←</td></tr> <tr><td colspan="2">Serie</td><td>100.6</td></tr> <tr><td colspan="2">Total</td><td>504.2</td></tr> </table>	41:	*10.8	↖	42:	10.0	↓	43:	9.7	→	44:	*10.5	↑	45:	8.4	→	46:	*10.7	→	47:	*10.5	↗	48:	10.1	↘	49:	10.0	↓	50:	9.9	←	Serie		100.6	Total		504.2	<p>60 Skott</p> 	<table border="1" style="width:100%; border-collapse: collapse;"> <tr><td>51:</td><td>9.9</td><td>↗</td></tr> <tr><td>52:</td><td>9.4</td><td>←</td></tr> <tr><td>53:</td><td>10.1</td><td>↗</td></tr> <tr><td>54:</td><td>9.3</td><td>→</td></tr> <tr><td>55:</td><td>*10.9</td><td>←</td></tr> <tr><td>56:</td><td>9.6</td><td>↗</td></tr> <tr><td>57:</td><td>9.7</td><td>→</td></tr> <tr><td>58:</td><td>*10.2</td><td>↓</td></tr> <tr><td>59:</td><td>*10.2</td><td>↓</td></tr> <tr><td>60:</td><td>10.1</td><td>↗</td></tr> <tr><td colspan="2">Serie</td><td>99.4</td></tr> <tr><td colspan="2">Total</td><td>603.6</td></tr> </table>	51:	9.9	↗	52:	9.4	←	53:	10.1	↗	54:	9.3	→	55:	*10.9	←	56:	9.6	↗	57:	9.7	→	58:	*10.2	↓	59:	*10.2	↓	60:	10.1	↗	Serie		99.4	Total		603.6
41:	*10.8	↖																																																																									
42:	10.0	↓																																																																									
43:	9.7	→																																																																									
44:	*10.5	↑																																																																									
45:	8.4	→																																																																									
46:	*10.7	→																																																																									
47:	*10.5	↗																																																																									
48:	10.1	↘																																																																									
49:	10.0	↓																																																																									
50:	9.9	←																																																																									
Serie		100.6																																																																									
Total		504.2																																																																									
51:	9.9	↗																																																																									
52:	9.4	←																																																																									
53:	10.1	↗																																																																									
54:	9.3	→																																																																									
55:	*10.9	←																																																																									
56:	9.6	↗																																																																									
57:	9.7	→																																																																									
58:	*10.2	↓																																																																									
59:	*10.2	↓																																																																									
60:	10.1	↗																																																																									
Serie		99.4																																																																									
Total		603.6																																																																									

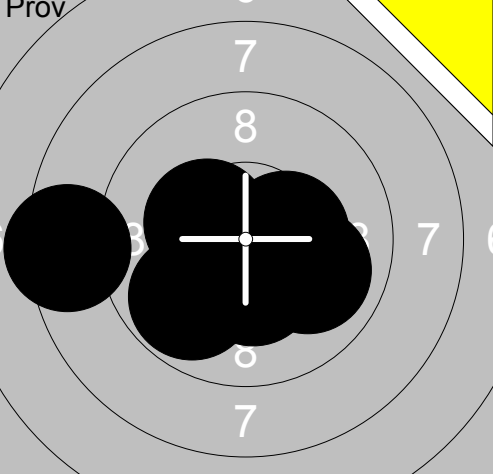
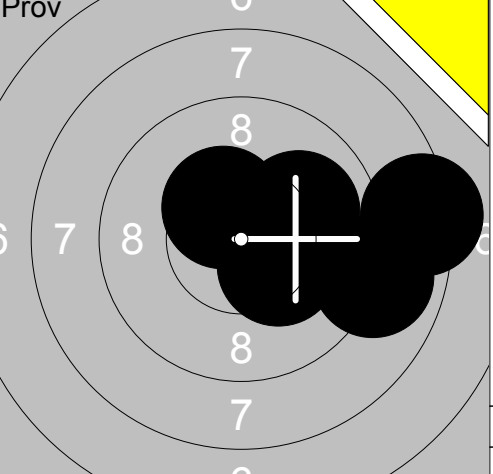
	<table border="1" style="width:100%; border-collapse: collapse;"> <tr><td>1:</td><td>10.0</td><td>↘</td></tr> <tr><td>2:</td><td>*10.6</td><td>↓</td></tr> <tr><td>3:</td><td>*10.3</td><td>↗</td></tr> <tr><td>4:</td><td>*10.4</td><td>→</td></tr> <tr><td>5:</td><td>*10.3</td><td>↓</td></tr> <tr><td>6:</td><td>8.4</td><td>←</td></tr> <tr><td>7:</td><td>*10.4</td><td>↓</td></tr> <tr><td>8:</td><td>9.8</td><td>↙</td></tr> <tr><td>9:</td><td>*10.6</td><td>↓</td></tr> <tr><td>10:</td><td>*10.4</td><td>↘</td></tr> <tr><td colspan="2">Serie</td><td>101.2</td></tr> <tr><td colspan="2">Total</td><td>0.0</td></tr> </table>	1:	10.0	↘	2:	*10.6	↓	3:	*10.3	↗	4:	*10.4	→	5:	*10.3	↓	6:	8.4	←	7:	*10.4	↓	8:	9.8	↙	9:	*10.6	↓	10:	*10.4	↘	Serie		101.2	Total		0.0	 <table border="1" style="width:100%; border-collapse: collapse;"> <tr><td>11:</td><td>8.3</td><td>→</td></tr> <tr><td>12:</td><td>8.9</td><td>↘</td></tr> <tr><td>13:</td><td>10.0</td><td>↗</td></tr> <tr><td>14:</td><td>*10.3</td><td>↓</td></tr> <tr><td>15:</td><td>*10.4</td><td>↗</td></tr> <tr><td colspan="2">Serie</td><td>47.9</td></tr> <tr><td colspan="2">Total</td><td>0.0</td></tr> </table>	11:	8.3	→	12:	8.9	↘	13:	10.0	↗	14:	*10.3	↓	15:	*10.4	↗	Serie		47.9	Total		0.0
1:	10.0	↘																																																									
2:	*10.6	↓																																																									
3:	*10.3	↗																																																									
4:	*10.4	→																																																									
5:	*10.3	↓																																																									
6:	8.4	←																																																									
7:	*10.4	↓																																																									
8:	9.8	↙																																																									
9:	*10.6	↓																																																									
10:	*10.4	↘																																																									
Serie		101.2																																																									
Total		0.0																																																									
11:	8.3	→																																																									
12:	8.9	↘																																																									
13:	10.0	↗																																																									
14:	*10.3	↓																																																									
15:	*10.4	↗																																																									
Serie		47.9																																																									
Total		0.0																																																									

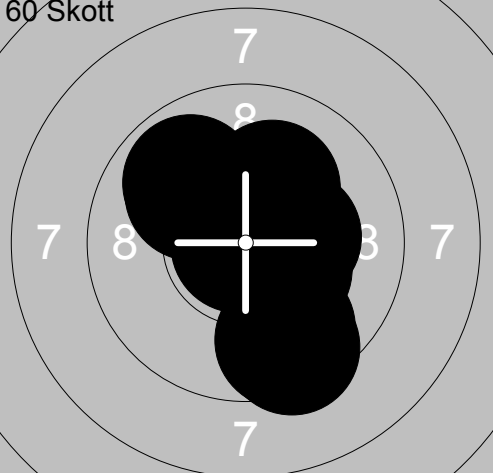
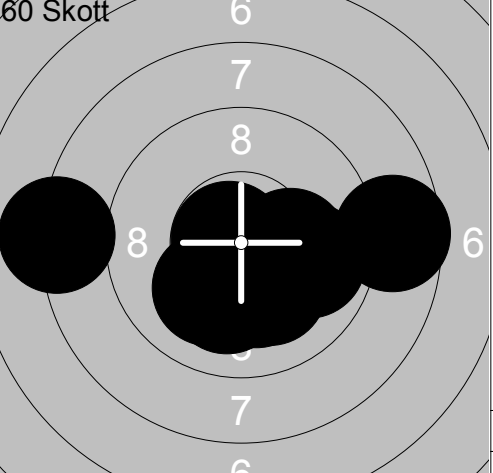
<p>60 Skott</p> 	<table border="1" style="width:100%; border-collapse: collapse;"> <tr><td>1:</td><td>9.6</td><td>↓</td></tr> <tr><td>2:</td><td>*10.9</td><td>←</td></tr> <tr><td>3:</td><td>*10.2</td><td>↗</td></tr> <tr><td>4:</td><td>9.4</td><td>↓</td></tr> <tr><td>5:</td><td>*10.3</td><td>↓</td></tr> <tr><td>6:</td><td>10.0</td><td>↗</td></tr> <tr><td>7:</td><td>*10.3</td><td>→</td></tr> <tr><td>8:</td><td>9.7</td><td>↓</td></tr> <tr><td>9:</td><td>9.9</td><td>↗</td></tr> <tr><td>10:</td><td>*10.9</td><td>←</td></tr> <tr><td colspan="2">Serie</td><td>101.2</td></tr> <tr><td colspan="2">Total</td><td>101.2</td></tr> </table>	1:	9.6	↓	2:	*10.9	←	3:	*10.2	↗	4:	9.4	↓	5:	*10.3	↓	6:	10.0	↗	7:	*10.3	→	8:	9.7	↓	9:	9.9	↗	10:	*10.9	←	Serie		101.2	Total		101.2	<p>60 Skott</p>  <table border="1" style="width:100%; border-collapse: collapse;"> <tr><td>11:</td><td>*10.8</td><td>←</td></tr> <tr><td>12:</td><td>*10.2</td><td>↓</td></tr> <tr><td>13:</td><td>10.1</td><td>↙</td></tr> <tr><td>14:</td><td>8.1</td><td>←</td></tr> <tr><td>15:</td><td>10.1</td><td>↓</td></tr> <tr><td>16:</td><td>8.6</td><td>→</td></tr> <tr><td>17:</td><td>9.9</td><td>→</td></tr> <tr><td>18:</td><td>10.1</td><td>↓</td></tr> <tr><td>19:</td><td>*10.2</td><td>→</td></tr> <tr><td>20:</td><td>*10.2</td><td>↘</td></tr> <tr><td colspan="2">Serie</td><td>98.3</td></tr> <tr><td colspan="2">Total</td><td>199.5</td></tr> </table>	11:	*10.8	←	12:	*10.2	↓	13:	10.1	↙	14:	8.1	←	15:	10.1	↓	16:	8.6	→	17:	9.9	→	18:	10.1	↓	19:	*10.2	→	20:	*10.2	↘	Serie		98.3	Total		199.5
1:	9.6	↓																																																																								
2:	*10.9	←																																																																								
3:	*10.2	↗																																																																								
4:	9.4	↓																																																																								
5:	*10.3	↓																																																																								
6:	10.0	↗																																																																								
7:	*10.3	→																																																																								
8:	9.7	↓																																																																								
9:	9.9	↗																																																																								
10:	*10.9	←																																																																								
Serie		101.2																																																																								
Total		101.2																																																																								
11:	*10.8	←																																																																								
12:	*10.2	↓																																																																								
13:	10.1	↙																																																																								
14:	8.1	←																																																																								
15:	10.1	↓																																																																								
16:	8.6	→																																																																								
17:	9.9	→																																																																								
18:	10.1	↓																																																																								
19:	*10.2	→																																																																								
20:	*10.2	↘																																																																								
Serie		98.3																																																																								
Total		199.5																																																																								

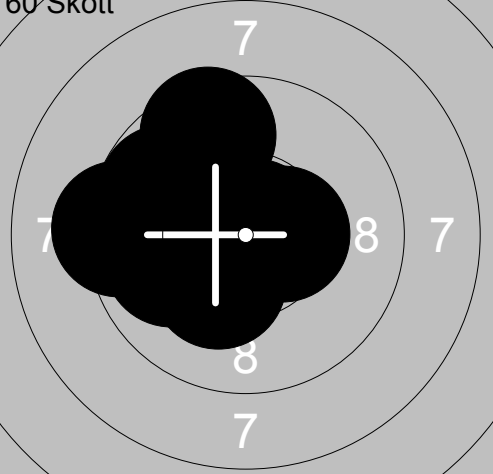
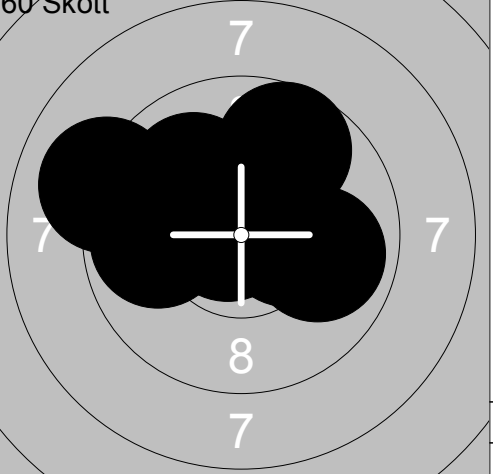
<p>60 Skott</p> 	<table border="1" style="width:100%; border-collapse: collapse;"> <tr><td>21:</td><td>*10.5</td><td>→</td></tr> <tr><td>22:</td><td>9.9</td><td>←</td></tr> <tr><td>23:</td><td>*10.8</td><td>↗</td></tr> <tr><td>24:</td><td>9.5</td><td>↗</td></tr> <tr><td>25:</td><td>9.3</td><td>←</td></tr> <tr><td>26:</td><td>*10.7</td><td>↓</td></tr> <tr><td>27:</td><td>9.8</td><td>↗</td></tr> <tr><td>28:</td><td>*10.6</td><td>→</td></tr> <tr><td>29:</td><td>*10.3</td><td>←</td></tr> <tr><td>30:</td><td>*10.2</td><td>↓</td></tr> <tr><td colspan="2">Serie</td><td>101.6</td></tr> <tr><td colspan="2">Total</td><td>301.1</td></tr> </table>	21:	*10.5	→	22:	9.9	←	23:	*10.8	↗	24:	9.5	↗	25:	9.3	←	26:	*10.7	↓	27:	9.8	↗	28:	*10.6	→	29:	*10.3	←	30:	*10.2	↓	Serie		101.6	Total		301.1	<p>60 Skott</p>  <table border="1" style="width:100%; border-collapse: collapse;"> <tr><td>31:</td><td>*10.8</td><td>←</td></tr> <tr><td>32:</td><td>9.9</td><td>→</td></tr> <tr><td>33:</td><td>9.9</td><td>←</td></tr> <tr><td>34:</td><td>*10.5</td><td>↗</td></tr> <tr><td>35:</td><td>9.7</td><td>↗</td></tr> <tr><td>36:</td><td>*10.5</td><td>↖</td></tr> <tr><td>37:</td><td>9.9</td><td>←</td></tr> <tr><td>38:</td><td>9.1</td><td>↖</td></tr> <tr><td>39:</td><td>10.0</td><td>↗</td></tr> <tr><td>40:</td><td>*10.3</td><td>→</td></tr> <tr><td colspan="2">Serie</td><td>100.6</td></tr> <tr><td colspan="2">Total</td><td>401.7</td></tr> </table>	31:	*10.8	←	32:	9.9	→	33:	9.9	←	34:	*10.5	↗	35:	9.7	↗	36:	*10.5	↖	37:	9.9	←	38:	9.1	↖	39:	10.0	↗	40:	*10.3	→	Serie		100.6	Total		401.7
21:	*10.5	→																																																																								
22:	9.9	←																																																																								
23:	*10.8	↗																																																																								
24:	9.5	↗																																																																								
25:	9.3	←																																																																								
26:	*10.7	↓																																																																								
27:	9.8	↗																																																																								
28:	*10.6	→																																																																								
29:	*10.3	←																																																																								
30:	*10.2	↓																																																																								
Serie		101.6																																																																								
Total		301.1																																																																								
31:	*10.8	←																																																																								
32:	9.9	→																																																																								
33:	9.9	←																																																																								
34:	*10.5	↗																																																																								
35:	9.7	↗																																																																								
36:	*10.5	↖																																																																								
37:	9.9	←																																																																								
38:	9.1	↖																																																																								
39:	10.0	↗																																																																								
40:	*10.3	→																																																																								
Serie		100.6																																																																								
Total		401.7																																																																								

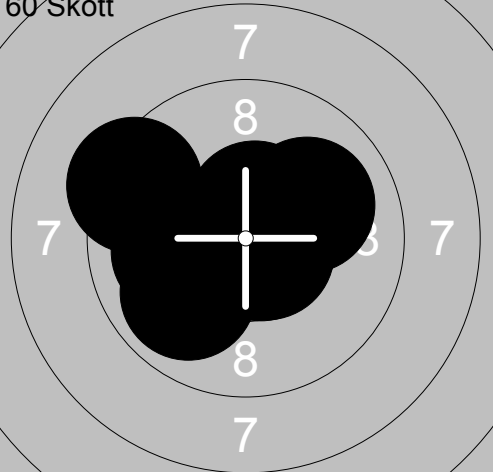
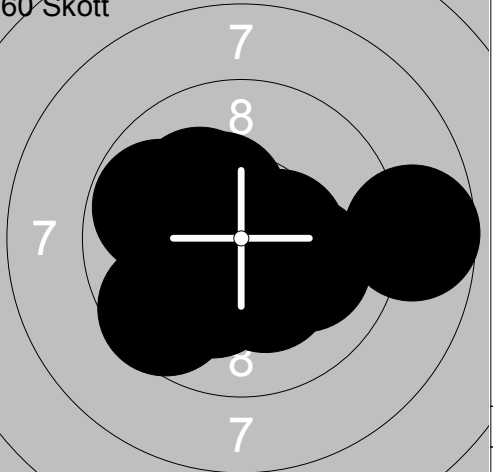
<p>60 Skott</p> 	<table border="1" style="width:100%; border-collapse: collapse;"> <tr><td>41:</td><td>10.0</td><td>↗</td></tr> <tr><td>42:</td><td>*10.6</td><td>↙</td></tr> <tr><td>43:</td><td>10.1</td><td>←</td></tr> <tr><td>44:</td><td>*10.5</td><td>↗</td></tr> <tr><td>45:</td><td>9.9</td><td>↙</td></tr> <tr><td>46:</td><td>*10.7</td><td>↘</td></tr> <tr><td>47:</td><td>*10.6</td><td>→</td></tr> <tr><td>48:</td><td>*10.6</td><td>↘</td></tr> <tr><td>49:</td><td>*10.5</td><td>↗</td></tr> <tr><td>50:</td><td>9.3</td><td>↖</td></tr> <tr><td colspan="2">Serie</td><td>102.8</td></tr> <tr><td colspan="2">Total</td><td>504.5</td></tr> </table>	41:	10.0	↗	42:	*10.6	↙	43:	10.1	←	44:	*10.5	↗	45:	9.9	↙	46:	*10.7	↘	47:	*10.6	→	48:	*10.6	↘	49:	*10.5	↗	50:	9.3	↖	Serie		102.8	Total		504.5	<p>60 Skott</p>  <table border="1" style="width:100%; border-collapse: collapse;"> <tr><td>51:</td><td>*10.4</td><td>↗</td></tr> <tr><td>52:</td><td>*10.9</td><td>↓</td></tr> <tr><td>53:</td><td>*10.5</td><td>→</td></tr> <tr><td>54:</td><td>*10.2</td><td>↗</td></tr> <tr><td>55:</td><td>*10.3</td><td>↓</td></tr> <tr><td>56:</td><td>9.6</td><td>↙</td></tr> <tr><td>57:</td><td>9.8</td><td>↖</td></tr> <tr><td>58:</td><td>*10.2</td><td>↓</td></tr> <tr><td>59:</td><td>10.1</td><td>↘</td></tr> <tr><td>60:</td><td>8.7</td><td>→</td></tr> <tr><td colspan="2">Serie</td><td>100.7</td></tr> <tr><td colspan="2">Total</td><td>605.2</td></tr> </table>	51:	*10.4	↗	52:	*10.9	↓	53:	*10.5	→	54:	*10.2	↗	55:	*10.3	↓	56:	9.6	↙	57:	9.8	↖	58:	*10.2	↓	59:	10.1	↘	60:	8.7	→	Serie		100.7	Total		605.2
41:	10.0	↗																																																																								
42:	*10.6	↙																																																																								
43:	10.1	←																																																																								
44:	*10.5	↗																																																																								
45:	9.9	↙																																																																								
46:	*10.7	↘																																																																								
47:	*10.6	→																																																																								
48:	*10.6	↘																																																																								
49:	*10.5	↗																																																																								
50:	9.3	↖																																																																								
Serie		102.8																																																																								
Total		504.5																																																																								
51:	*10.4	↗																																																																								
52:	*10.9	↓																																																																								
53:	*10.5	→																																																																								
54:	*10.2	↗																																																																								
55:	*10.3	↓																																																																								
56:	9.6	↙																																																																								
57:	9.8	↖																																																																								
58:	*10.2	↓																																																																								
59:	10.1	↘																																																																								
60:	8.7	→																																																																								
Serie		100.7																																																																								
Total		605.2																																																																								

<p>Prov</p>	<p>1: *10.9 ↘                  2: *10.4 ↘                  3: *10.4 →                  4: *10.7 ↘                  5: 9.9 ↘                  6: *10.5 ↘                  7: *10.6 →                  8: *10.5 ↗                  9: 9.6 →                  10: *10.2 ↘</p> <p>Serie 103.7 Total 0.0</p>	<p>Prov</p>	<p>11: 10.1 →                  12: *10.4 ↘                  13: 10.1 →</p> <p>Serie 30.6 Total 0.0</p>
<p>40 Skott</p>	<p>1: 9.3 →                  2: *10.3 →                  3: *10.8 ↘                  4: *10.3 ↘                  5: 10.1 ←                  6: *10.8 ↘                  7: *10.5 ↘                  8: *10.2 →                  9: 10.0 ↓                  10: *10.5 ↘</p> <p>Serie 102.8 Total 102.8</p>	<p>40 Skott</p>	<p>11: *10.8 ↘                  12: 10.0 ↘                  13: 9.5 →                  14: 9.7 ↓                  15: 9.4 ←                  16: *10.8 ↗                  17: *10.3 ↘                  18: *10.6 ↘                  19: *10.5 ↗                  20: 10.0 ↘</p> <p>Serie 101.6 Total 204.4</p>
<p>40 Skott</p>	<p>21: *10.2 →                  22: 10.1 →                  23: *10.7 ↘                  24: *10.8 ↗                  25: *10.3 ↘                  26: *10.2 ↘                  27: 9.8 ←                  28: 8.8 →                  29: 10.1 ↓                  30: *10.6 ↘</p> <p>Serie 101.6 Total 306.0</p>	<p>40 Skott</p>	<p>31: *10.6 ↘                  32: *10.5 ↘                  33: *10.4 →                  34: 10.0 ←                  35: *10.6 →                  36: 9.9 ↘                  37: 9.6 →                  38: 9.9 ←                  39: 9.6 ↘                  40: 9.9 →</p> <p>Serie 101.0 Total 407.0</p>

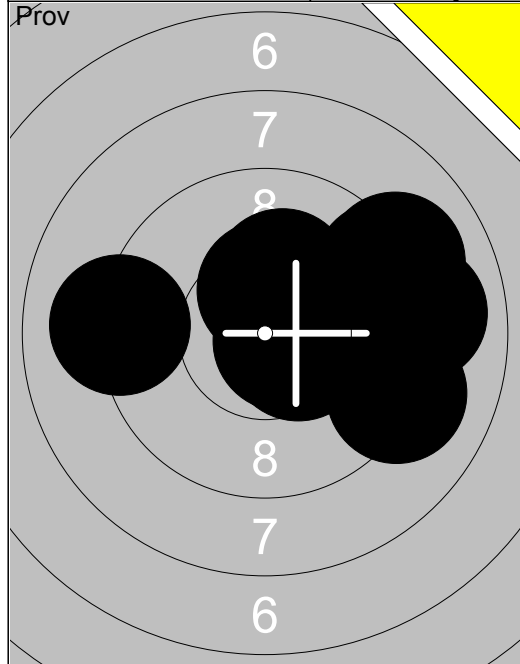

1: *10.4	↑
2: *10.2	↑
3: 9.2	→
4: *10.5	↘
5: 9.1	→
6: 9.0	→
7: 9.1	←
8: *10.7	↘
9: 9.1	↗
10: *10.2	↗
Serie 97.5	
Total 0.0	

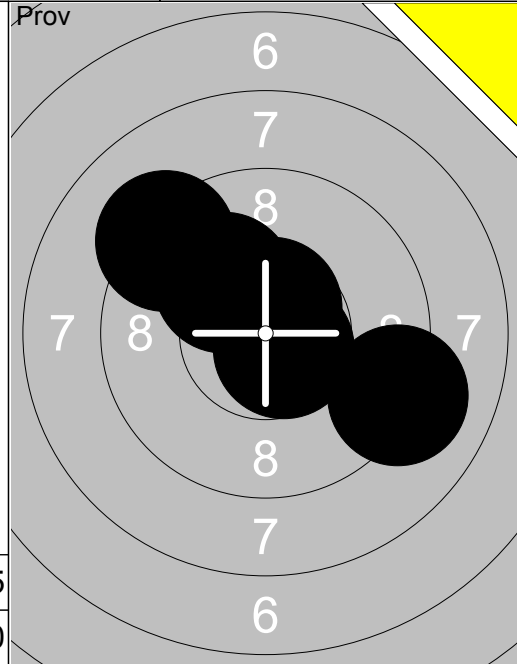

11: *10.6	↘
12: 10.1	↖
13: 9.2	↖
14: 9.1	→
15: *10.6	↑
Serie 49.6	
Total 0.0	

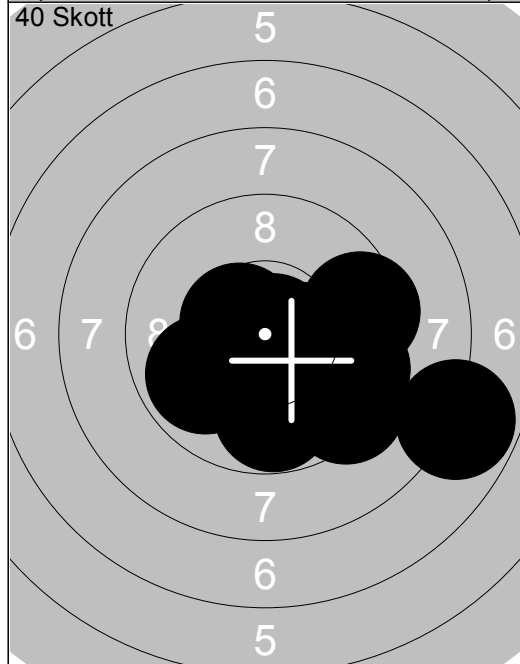

1: *10.3	↘
2: *10.8	→
3: 9.9	↖
4: 10.1	↓
5: 9.5	→
6: 7.8	→
7: 9.6	→
8: *10.5	↖
9: 9.8	↓
10: 9.3	↘
Serie 97.6	
Total 97.6	

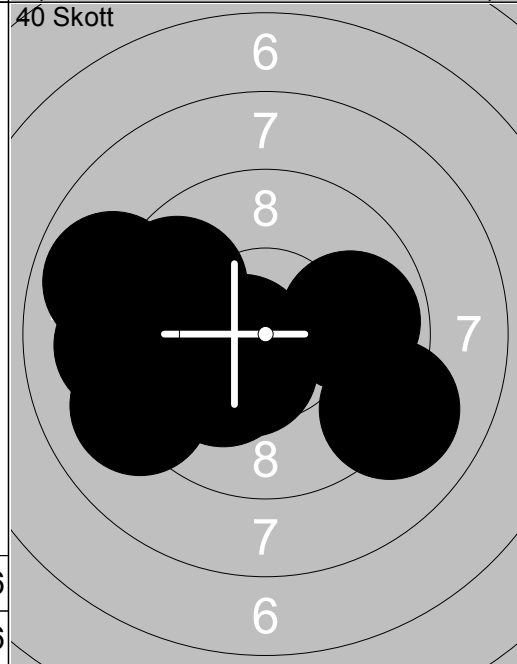

11: *10.6	↖
12: 9.1	←
13: 9.1	↘
14: 9.1	↖
15: *10.2	↖
16: *10.5	↖
17: *10.5	↖
18: 9.9	→
19: 8.9	↖
20: 9.7	↖
Serie 97.6	
Total 195.2	

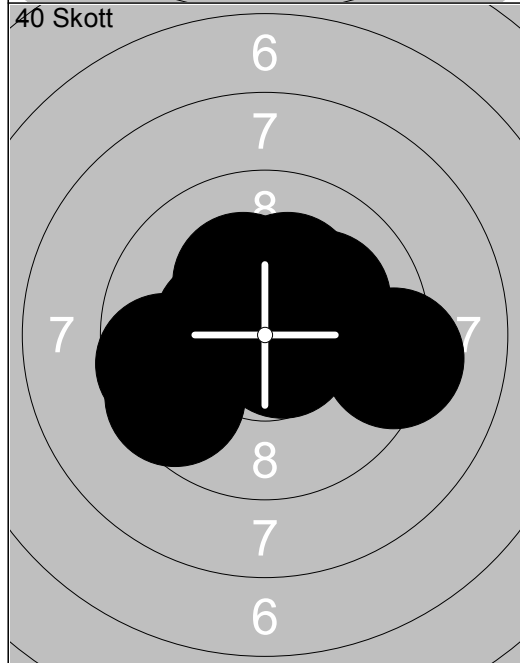

21: *10.9	↖
22: *10.7	↘
23: *10.2	↖
24: 9.6	↖
25: 10.1	↗
26: *10.2	↑
27: 9.6	←
28: *10.8	↑
29: 9.3	→
30: *10.4	↖
Serie 101.8	
Total 297.0	

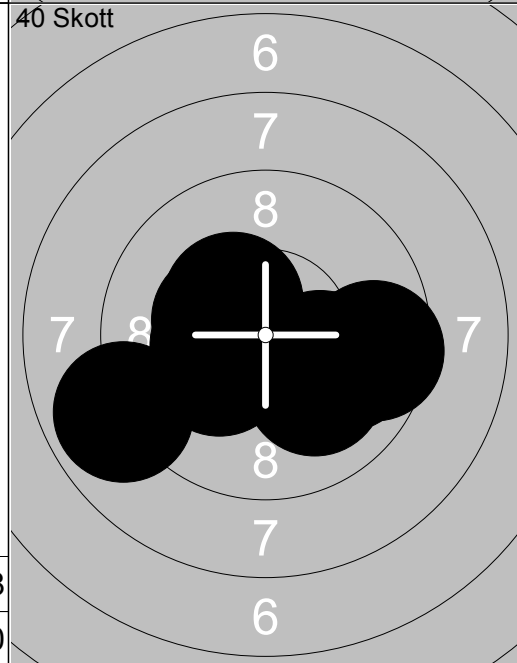

31: *10.7	↖
32: 8.9	↖
33: *10.2	↖
34: *10.4	↖
35: 10.0	↘
36: *10.2	↘
37: 9.9	→
38: *10.4	↖
39: *10.4	↖
40: 9.6	→
Serie 100.7	
Total 397.7	



<p>Prov</p> <p style="text-align: center;">6 7 7 8 7 7 6</p>	<p>1: 9.7 ↑ 2: 10.1 ↑ 3: 9.1 ← 4: *10.3 ↑ 5: 9.8 ↓ 6: 9.5 ↓ 7: 9.6 ↑ 8: *10.3 ↑ 9: *10.2 ↘ 10: 9.8 ↘</p> <p style="text-align: right;">Serie 98.4 Total 0.0</p>	<p>Prov</p> <p style="text-align: center;">6 7 8 8 7 7 6</p>	<p>11: 9.0 ← 12: *10.7 ↖ 13: 9.6 ↖ 14: *10.2 ↘ 15: *10.2 ↘ 16: *10.3 ↗</p> <p style="text-align: right;">Serie 60.0 Total 0.0</p>
<p>40 Skott</p> <p style="text-align: center;">6 7 7 8 7 7 6</p>	<p>1: 10.1 ↑ 2: 9.9 ↖ 3: 9.3 ← 4: 9.8 ↑ 5: 8.6 → 6: *10.4 ↘ 7: 9.1 ↖ 8: *10.2 ↘ 9: *10.5 ↖ 10: 9.2 ↘</p> <p style="text-align: right;">Serie 97.1 Total 97.1</p>	<p>40 Skott</p> <p style="text-align: center;">6 7 8 8 7 7 6</p>	<p>11: 9.7 ↖ 12: *10.3 ↖ 13: 9.7 → 14: 9.6 ↗ 15: 9.9 ← 16: *10.3 ↓ 17: 9.6 ↖ 18: 9.8 ↓ 19: 9.9 ↓ 20: 10.1 ←</p> <p style="text-align: right;">Serie 98.9 Total 196.0</p>
<p>40 Skott</p> <p style="text-align: center;">6 7 7 7 7 7 6</p>	<p>21: 10.0 → 22: 9.1 ↓ 23: *10.2 ↓ 24: 9.0 → 25: 9.3 ↘ 26: 8.8 ← 27: 9.7 ↗ 28: *10.2 ↑ 29: 9.8 ↑ 30: 9.5 ←</p> <p style="text-align: right;">Serie 95.6 Total 291.6</p>	<p>40 Skott</p> <p style="text-align: center;">6 7 8 8 7 7 6</p>	<p>31: 9.6 ← 32: *10.8 → 33: 9.8 → 34: *10.4 → 35: 9.8 ↖ 36: 9.9 ← 37: 9.5 → 38: 9.3 ↑ 39: *10.3 ↓ 40: *10.4 ↖</p> <p style="text-align: right;">Serie 99.8 Total 391.4</p>



Prov 	1: *10.6 → 2: *10.4 ↙ 3: *10.8 ↘ 4: *10.4 ↗ 5: 9.6 → 6: *10.6 ↘ 7: *10.6 ↗ 8: *10.6 ↘ 9: 9.4 → 10: *10.4 ↙ <hr/> Serie 103.4 Total 0.0	Prov 	11: *10.4 ↙ 12: *10.5 ↘ 13: 10.1 ↘ <hr/> Serie 31.0 Total 0.0
----------	---	----------	---

40 Skott 	1: *10.2 → 2: 9.8 → 3: 9.8 ↘ 4: 10.1 ↙ 5: *10.5 ↘ 6: *10.4 ↗ 7: *10.9 → 8: 10.0 ↗ 9: *10.3 ↘ 10: 10.1 ↗ <hr/> Serie 102.1 Total 102.1	40 Skott 	11: *10.4 ↘ 12: 9.4 ↙ 13: 10.1 → 14: *10.4 ↘ 15: *10.4 ↗ 16: *10.4 ↘ 17: 10.1 → 18: *10.3 ↙ 19: *10.4 ↘ 20: *10.4 ↗ <hr/> Serie 102.3 Total 204.4
--------------	--	--------------	--

40 Skott 	21: *10.5 ↘ 22: *10.5 ↘ 23: *10.3 → 24: *10.3 ↗ 25: *10.9 ↘ 26: 9.7 ↗ 27: *10.8 ↗ 28: *10.6 ↘ 29: *10.8 ↘ 30: 9.5 ← <hr/> Serie 103.9 Total 308.3	40 Skott 	31: 10.0 → 32: *10.4 ↗ 33: *10.7 ↗ 34: *10.8 ↘ 35: *10.2 ↘ 36: *10.3 ↘ 37: *10.7 ↙ 38: *10.3 ↘ 39: *10.2 ↘ 40: *10.3 ↘ <hr/> Serie 103.9 Total 412.2
--------------	--	--------------	---

<p>Prov</p>	<p>1: *10.2↑</p> <p>2: 9.7 ↑</p> <p>3: 9.7 →</p> <p>4: 10.0→</p> <p>5: 10.0↗</p> <p>6: 10.1 ↑</p> <p>7: 8.6 ↘</p> <p>8: *10.4↗</p> <p>9: 10.0↗</p> <p>10: *10.2↗</p>	<p>Prov</p>	<p>11: 9.6 →</p> <p>12: *10.2↖</p> <p>13: *10.6↖</p> <p>14: *10.4↗</p> <p>15: 9.3 ↘</p>
Serie 98.9		Serie 50.1	
Total 0.0		Total 0.0	

<p>40 Skott</p>	<p>1: *10.3↖</p> <p>2: 9.8 ↘</p> <p>3: *10.4↑</p> <p>4: 10.0 ↘</p> <p>5: 9.6 →</p> <p>6: 9.7 →</p> <p>7: 9.9 →</p> <p>8: 10.0↗</p> <p>9: *10.3↘</p> <p>10: *10.3↘</p>	<p>40 Skott</p>	<p>11: 10.1 ↘</p> <p>12: *10.3↗</p> <p>13: *10.4↘</p> <p>14: *10.6↘</p> <p>15: 9.8 ↖</p> <p>16: 10.1↖</p> <p>17: 9.6 ↖</p> <p>18: 10.1↖</p> <p>19: 9.9 ↘</p> <p>20: 9.9 ↖</p>
Serie 100.3		Serie 100.8	
Total 100.3		Total 201.1	

<p>40 Skott</p>	<p>21: *10.2↘</p> <p>22: 10.1↖</p> <p>23: *10.2↖</p> <p>24: *10.8↑</p> <p>25: 10.0→</p> <p>26: 9.5 ←</p> <p>27: *10.5↘</p> <p>28: 9.3 →</p> <p>29: 9.3 →</p> <p>30: *10.2↖</p>	<p>40 Skott</p>	<p>31: *10.5↖</p> <p>32: *10.5↖</p> <p>33: 9.4 ↖</p> <p>34: *10.4↘</p> <p>35: 10.0→</p> <p>36: 8.8 ↘</p> <p>37: *10.2↘</p> <p>38: 9.3 ↖</p> <p>39: *10.6↖</p> <p>40: 9.8 ↘</p>
Serie 100.1		Serie 99.5	
Total 301.2		Total 400.7	

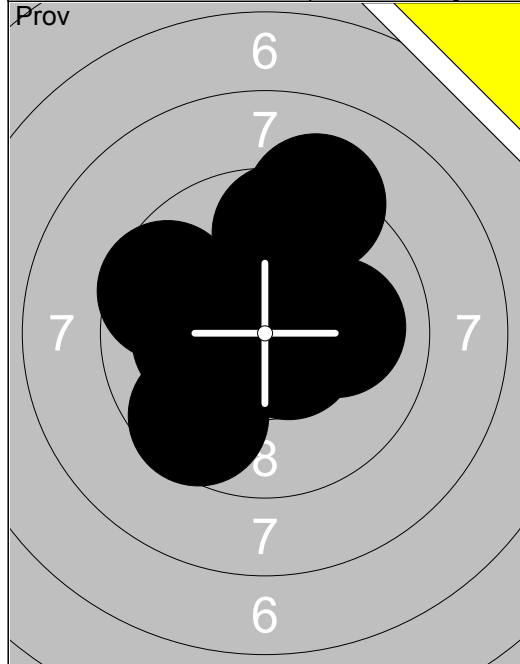

1: 9.7 ↑
2: 9.2 ↑
3: 9.6 ↙
4: 10.1 →
5: *10.4 ↗
6: *10.6 ↘
7: 9.6 ↘
8: 10.1 ←
9: *10.5 ↗
10: *10.6 ↘
Serie 100.4
Total 0.0

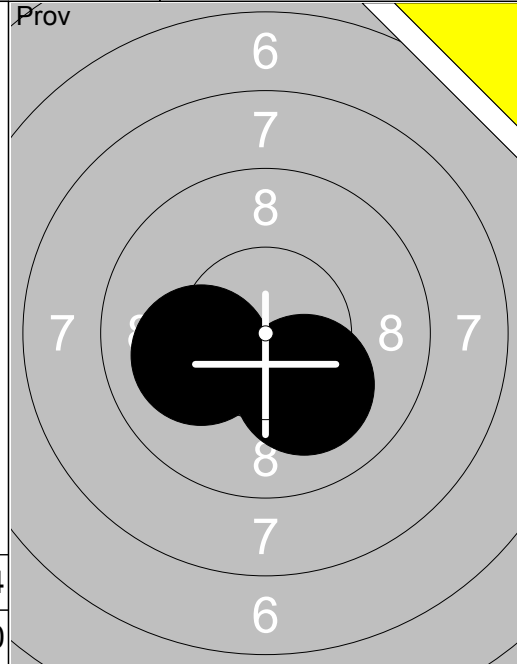

11: 10.1 ↘
12: 10.1 ↙
Serie 20.2
Total 0.0

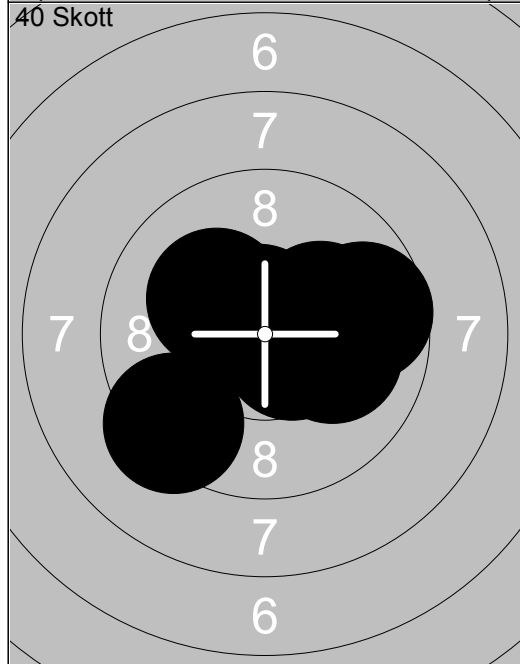

1: 9.3 ↘
2: 10.1 →
3: 9.7 →
4: *10.7 ↗
5: *10.5 ↘
6: *10.6 →
7: *10.7 ↗
8: *10.2 ↘
9: 10.1 →
10: *10.2 →
Serie 102.1
Total 102.1

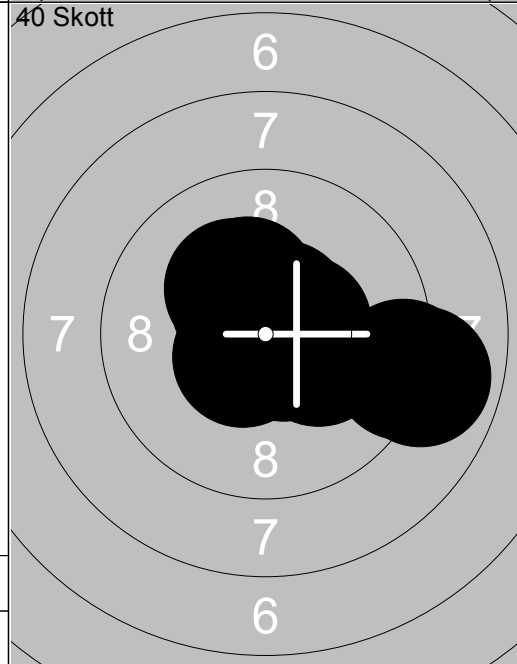

11: *10.5 →
12: *10.5 ↘
13: *10.2 →
14: *10.2 ↗
15: *10.6 ↗
16: *10.5 ↘
17: 8.9 →
18: 9.1 →
19: *10.3 ↗
20: *10.6 ↘
Serie 101.4
Total 203.5

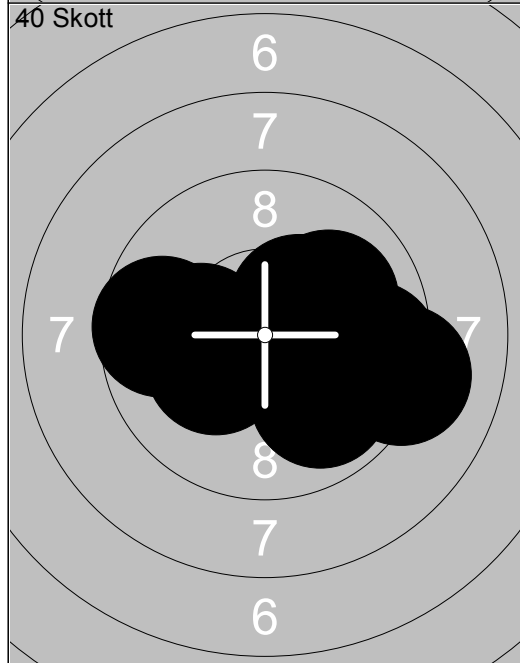

21: *10.7 ↘
22: 9.1 →
23: 9.9 →
24: 10.0 ↗
25: 9.6 →
26: 9.9 ↘
27: 10.1 ←
28: *10.2 ↘
29: 9.6 ←
30: *10.4 ↗
Serie 99.5
Total 303.0

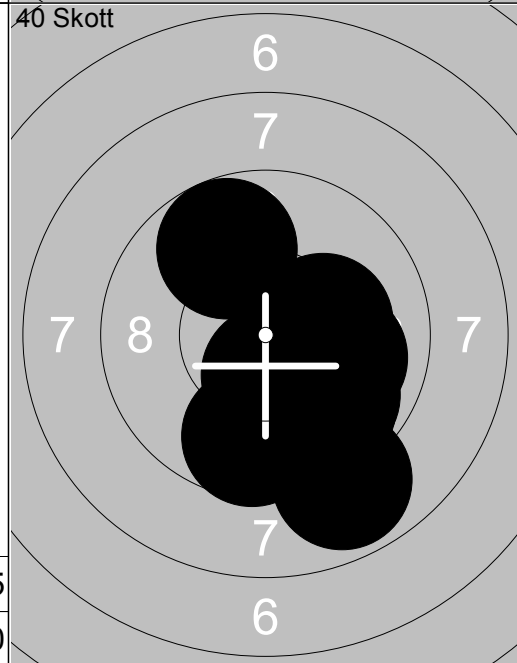

31: *10.4 ↘
32: 10.0 →
33: 9.6 ↘
34: 9.8 ↘
35: 9.8 ↘
36: 10.1 ↘
37: *10.3 ↘
38: *10.2 →
39: 9.7 ↗
40: 8.9 ↘
Serie 98.8
Total 401.8

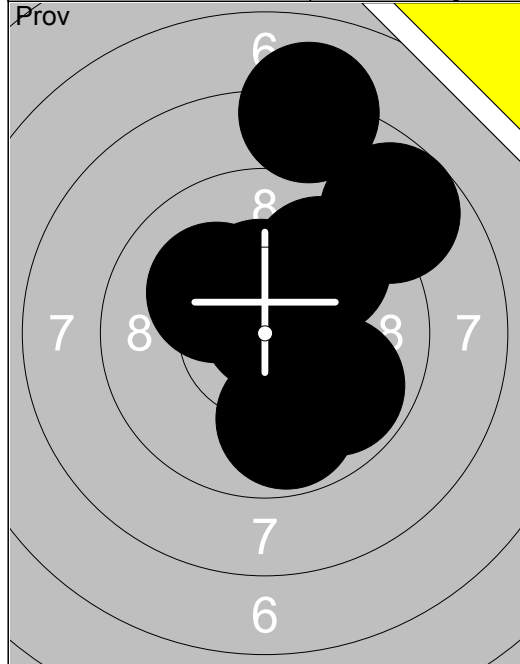

1:	10.1 ↖
2:	8.1 ↑
3:	8.7 ↗
4:	*10.2 ↗
5:	*10.4 ↑
6:	*10.8 ↗
7:	9.8 ↓
8:	*10.4 ↖
9:	9.8 ↘
10:	9.8 ↗
<b>Serie 98.1</b>	
<b>Total 0.0</b>	

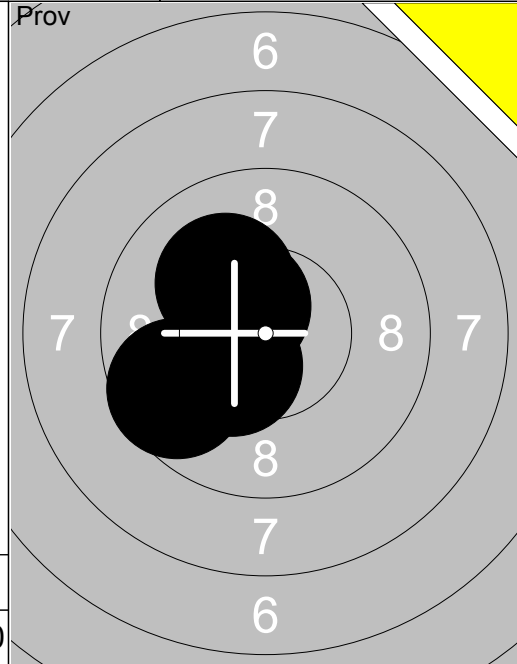

11:	9.6 ↖
12:	*10.5 ↖
13:	10.1 ↖
14:	*10.4 ↖
<b>Serie 40.6</b>	
<b>Total 0.0</b>	

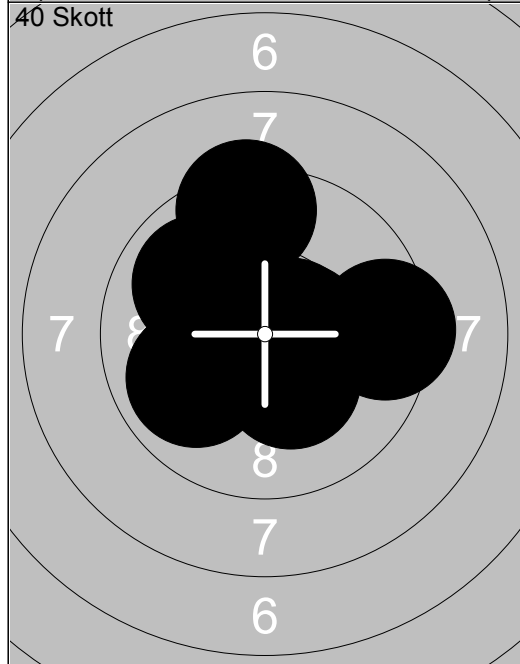

1:	*10.3 ↖
2:	9.9 ↖
3:	9.4 →
4:	9.9 ↖
5:	*10.6 →
6:	*10.5 →
7:	*10.7 ↖
8:	*10.4 ↖
9:	9.4 ↑
10:	*10.3 ↖
<b>Serie 101.4</b>	
<b>Total 101.4</b>	

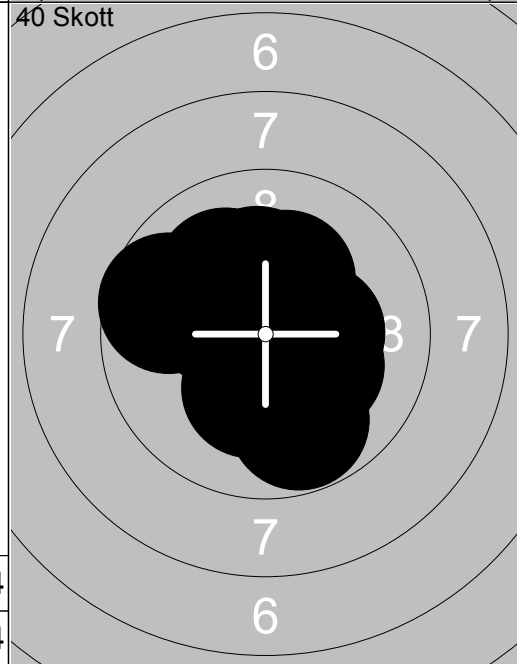

11:	*10.2 ↑
12:	*10.2 ↘
13:	9.8 ↓
14:	*10.5 ↘
15:	10.1 ↖
16:	9.6 ↖
17:	*10.3 →
18:	*10.2 ↖
19:	*10.2 ↑
20:	*10.4 ↖
<b>Serie 101.5</b>	
<b>Total 202.9</b>	

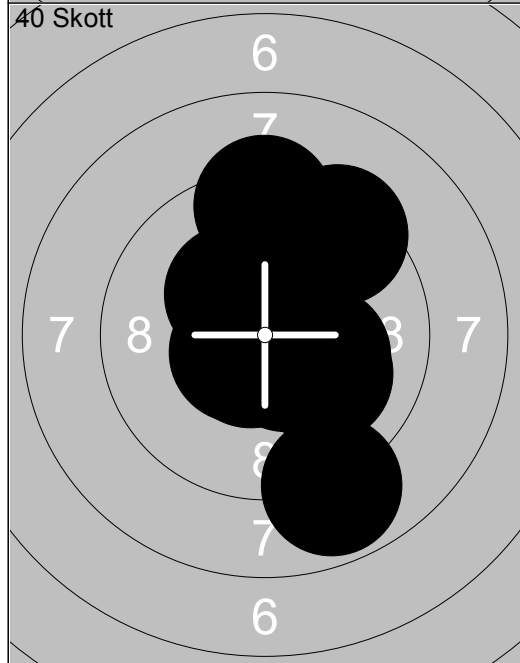

21:	*10.5 ↘
22:	10.0 ↑
23:	10.1 ↘
24:	*10.2 ↘
25:	*10.6 ↖
26:	9.4 ↗
27:	*10.6 ↖
28:	9.3 ↑
29:	*10.3 ↖
30:	8.8 ↓
<b>Serie 99.8</b>	
<b>Total 302.7</b>	

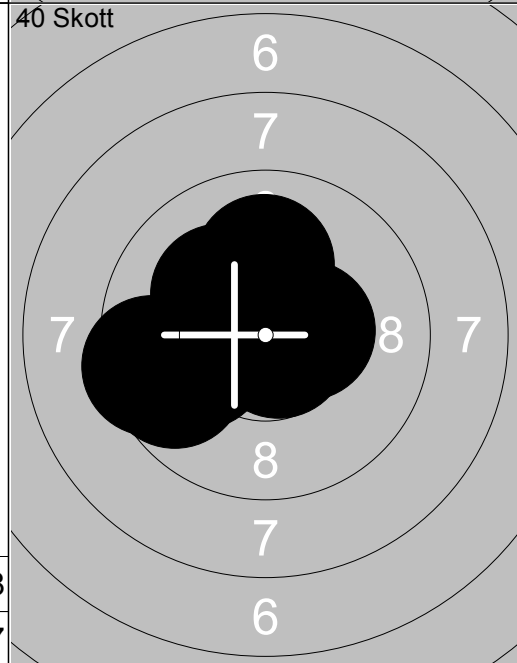

31:	*10.4 ↖
32:	*10.8 ↖
33:	*10.7 ↘
34:	9.7 ↖
35:	*10.6 ↖
36:	*10.4 →
37:	9.5 ↖
38:	10.0 ↖
39:	*10.2 ↖
40:	10.1 ↑
<b>Serie 102.4</b>	
<b>Total 405.1</b>	

<p>Prov</p>	<p>1: *10.6 ←</p> <p>2: *10.2 ↗</p> <p>3: *10.7 ↘</p> <p>4: 9.9 ←</p> <p>5: *10.6 →</p> <p>6: *10.7 ↗</p> <p>7: 9.8 ←</p> <p>8: *10.7 ↘</p> <p>9: 9.9 ←</p> <p>10: *10.6 ↘</p>	<p>Prov</p>	<p>11: 9.9 ↑</p> <p>12: *10.8 ↘</p> <p>13: 10.1 →</p> <p>14: *10.5 ↘</p> <p>15: *10.7 ↘</p> <p>16: *10.7 ←</p> <p>17: *10.7 ↗</p>
Serie 103.7		Serie 73.4	
Total 0.0		Total 0.0	

<p>40 Skott</p>	<p>1: *10.2 ↗</p> <p>2: *10.4 ↘</p> <p>3: *10.5 ↘</p> <p>4: *10.4 ←</p> <p>5: *10.5 ←</p> <p>6: 10.1 ↗</p> <p>7: *10.4 →</p> <p>8: *10.5 ↗</p> <p>9: *10.2 →</p> <p>10: 10.1 ↘</p>	<p>40 Skott</p>	<p>11: *10.6 →</p> <p>12: 9.9 ↓</p> <p>13: *10.4 ↘</p> <p>14: 9.5 ↓</p> <p>15: *10.5 ↗</p> <p>16: 9.5 →</p> <p>17: 9.9 →</p> <p>18: 9.9 →</p> <p>19: *10.8 ↗</p> <p>20: 9.8 ↓</p>
Serie 103.3		Serie 100.8	
Total 103.3		Total 204.1	

<p>40 Skott</p>	<p>21: *10.8 ↓</p> <p>22: *10.4 ↓</p> <p>23: *10.8 →</p> <p>24: *10.5 ↘</p> <p>25: *10.9 ↗</p> <p>26: *10.3 →</p> <p>27: 10.1 ←</p> <p>28: *10.3 →</p> <p>29: 9.9 ←</p> <p>30: 10.1 ↗</p>	<p>40 Skott</p>	<p>31: *10.4 ↗</p> <p>32: *10.8 ↘</p> <p>33: *10.8 →</p> <p>34: *10.2 ↗</p> <p>35: *10.4 ↗</p> <p>36: 9.9 ←</p> <p>37: *10.6 ↘</p> <p>38: 9.7 ←</p> <p>39: *10.4 ↗</p> <p>40: 10.1 ↘</p>
Serie 104.1		Serie 103.3	
Total 308.2		Total 411.5	

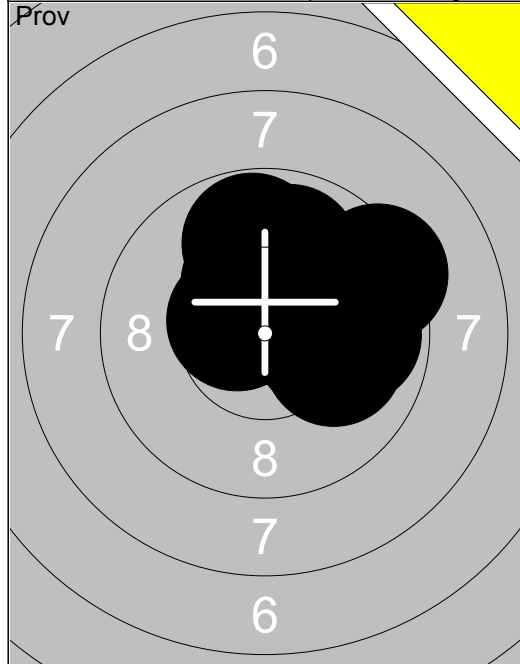

1:	10.0 →
2:	9.8 →
3:	10.0 ↑
4:	9.9 ↑
5:	*10.2 →
6:	*10.5 ↑
7:	*10.6 ↘
8:	*10.3 ↑
9:	9.3 →
10:	9.8 ↑
Serie 100.4	
Total 0.0	

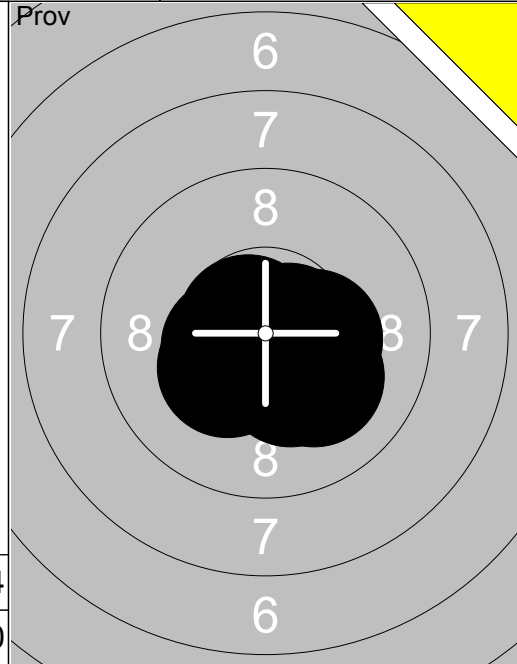

11:	*10.3 →
12:	*10.4 →
13:	*10.6 ↓
14:	10.1 ↘
15:	*10.7 →
16:	*10.7 ↘
17:	*10.5 ↘
18:	*10.3 ↓
19:	*10.3 ↘
Serie 93.9	
Total 0.0	

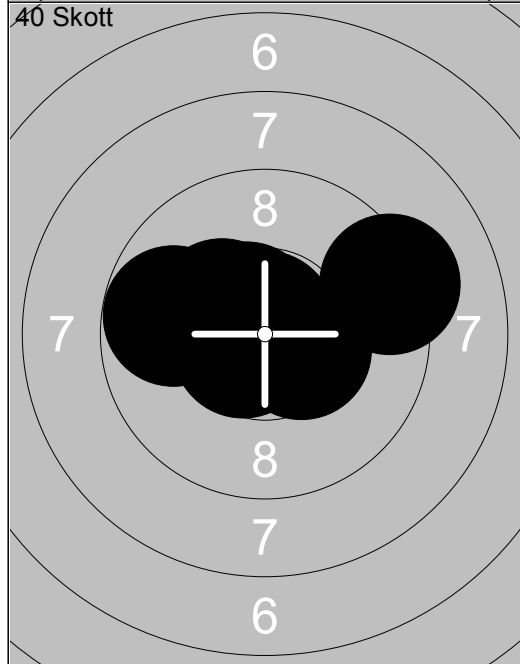

1:	*10.8 ↗
2:	*10.6 ↘
3:	*10.7 ↘
4:	*10.3 ↘
5:	*10.6 ↘
6:	*10.6 ↘
7:	*10.8 ↑
8:	9.8 ←
9:	*10.4 →
10:	9.2 →
Serie 103.8	
Total 103.8	

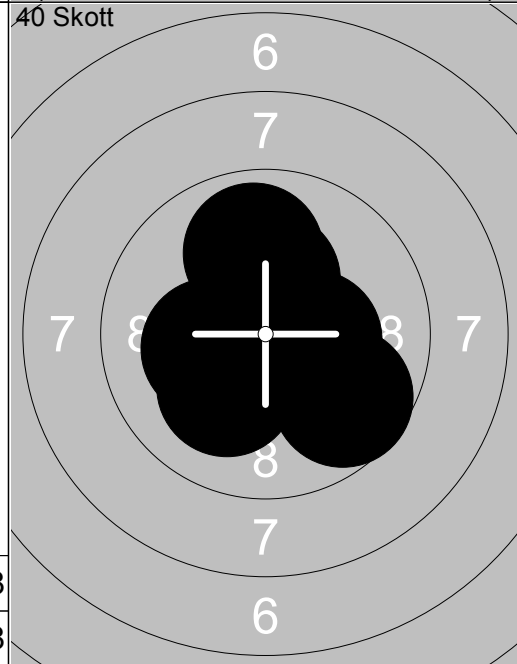

11:	*10.8 ↘
12:	*10.3 ↑
13:	*10.6 →
14:	*10.9 ↓
15:	*10.4 →
16:	*10.7 ↘
17:	9.7 ↘
18:	*10.2 ↘
19:	10.1 ↘
20:	9.9 ↑
Serie 103.6	
Total 207.4	

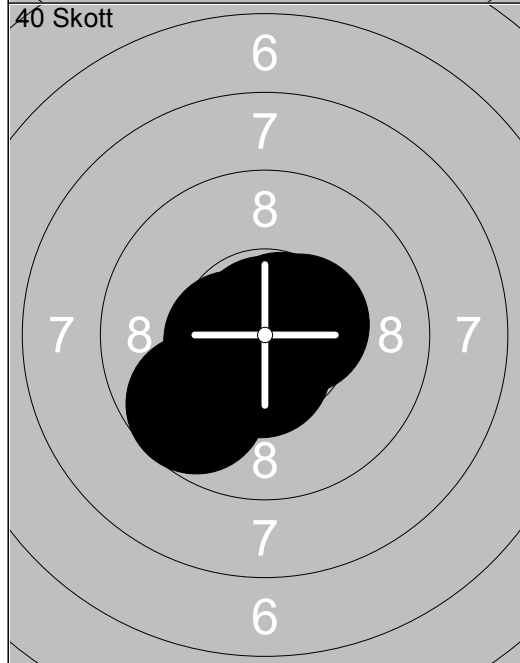

21:	*10.8 ↑
22:	*10.7 →
23:	*10.5 ↘
24:	*10.8 →
25:	*10.7 ↗
26:	*10.6 →
27:	*10.5 →
28:	*10.5 ↘
29:	9.7 ↘
30:	*10.5 ↓
Serie 105.3	
Total 312.7	

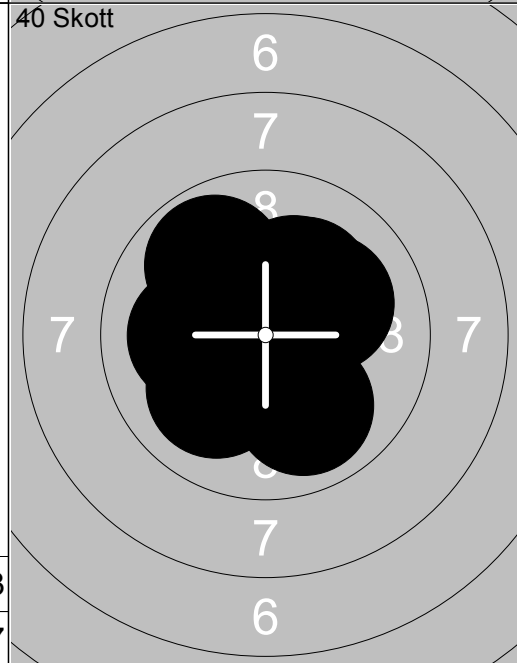

31:	*10.3 ↘
32:	10.0 ↘
33:	10.1 ←
34:	9.8 ↗
35:	*10.2 ↑
36:	*10.2 ↗
37:	10.1 →
38:	9.9 ↘
39:	*10.3 ↘
40:	*10.8 ↘
Serie 101.7	
Total 414.4	



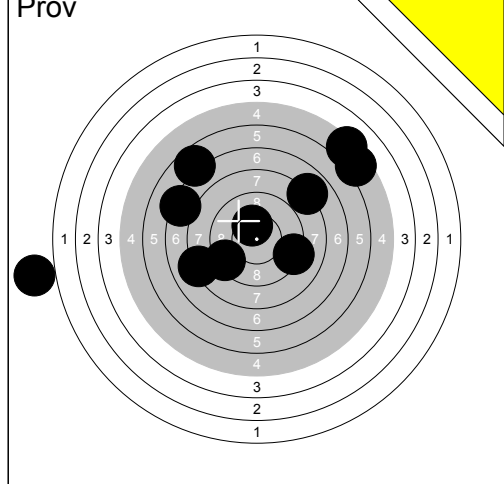

1:	5.5	↗
2:	9.2	↖
3:	7.9	↗
4:	0.0	←
5:	7.2	↖
6:	5.2	↗
7:	*10.3	↗
8:	6.6	↗
9:	9.2	→
10:	8.1	←
Serie		69.2
Total		0.0

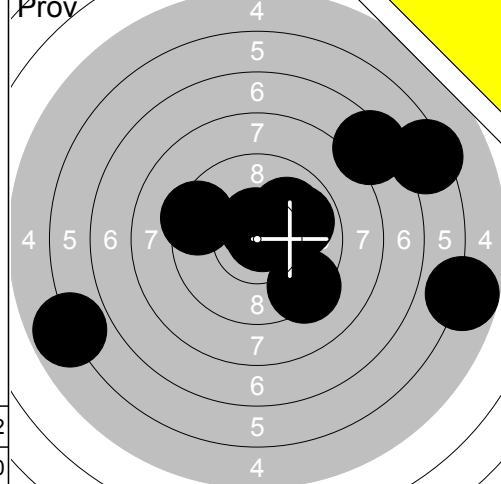

11:	9.9	↗
12:	*10.8	↗
13:	9.3	↘
14:	6.4	↗
15:	*10.6	↑
16:	9.4	↖
17:	10.0	↗
18:	5.7	→
19:	5.8	↖
20:	7.4	↗
Serie		85.3
Total		0.0

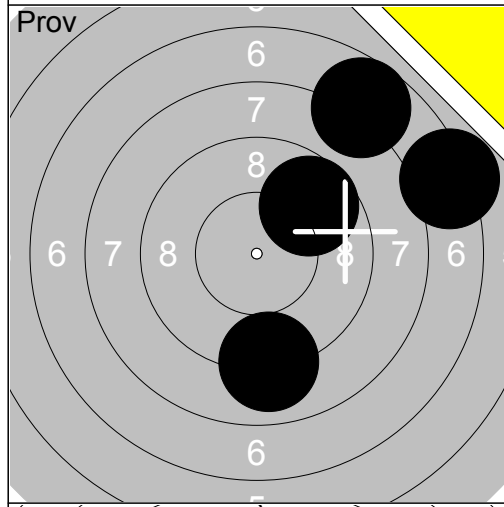

21:	7.7	↗
22:	7.2	→
23:	9.0	↘
24:	9.7	↗
Serie		33.6
Total		0.0

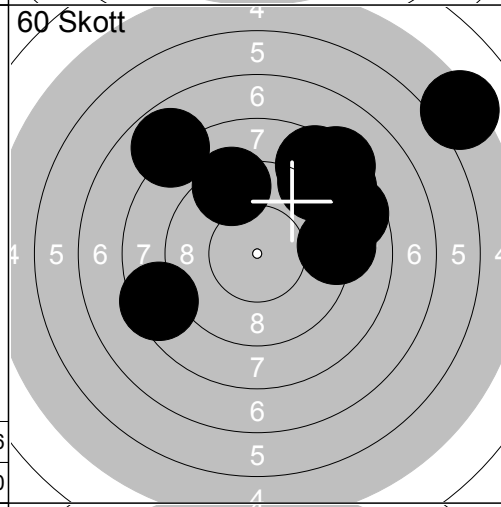

1:	8.6	↗
2:	9.1	→
3:	8.5	↗
4:	8.6	↗
5:	9.3	↑
6:	5.3	↗
7:	8.3	↗
8:	7.8	↖
9:	8.4	↖
10:	8.8	↗
Serie		82.7
Total		82.7

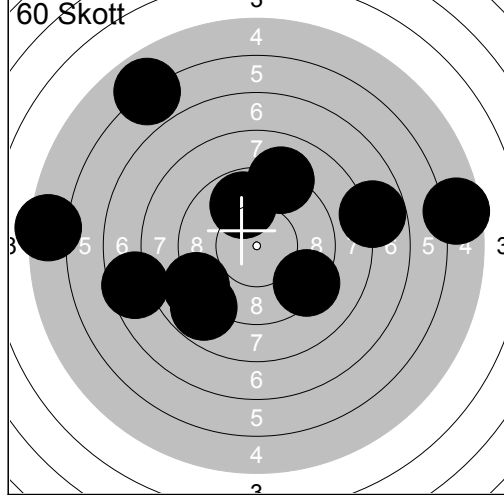

11:	7.7	→
12:	9.0	↖
13:	7.5	←
14:	8.8	↖
15:	9.8	↑
16:	5.5	→
17:	9.1	↗
18:	5.9	↗
19:	9.3	↘
20:	5.4	←
Serie		78.0
Total		160.7

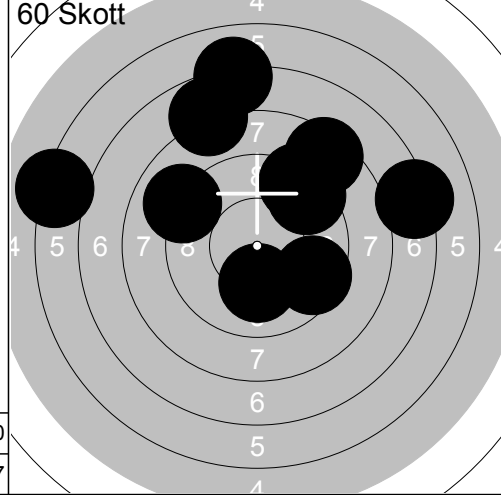

21:	8.4	↗
22:	9.5	↘
23:	9.2	↗
24:	7.2	→
25:	7.8	↑
26:	9.0	↖
27:	9.3	↗
28:	6.1	←
29:	7.0	↑
30:	10.1	↓
Serie		83.6
Total		244.3

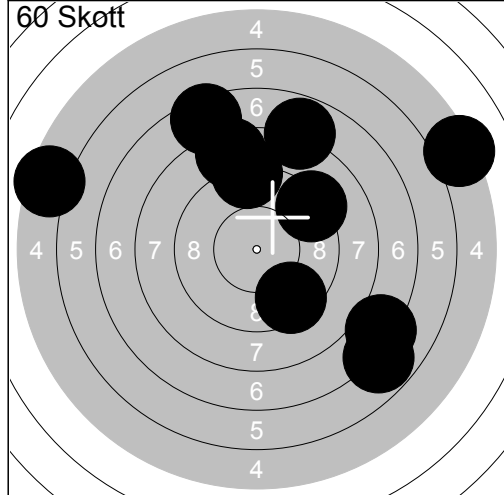

31:	5.4	←
32:	7.2	↘
33:	9.4	↘
34:	9.2	↗
35:	7.8	↗
36:	8.4	↑
37:	9.0	↑
38:	7.4	↗
39:	6.8	↘
40:	5.2	↗
Serie		75.8
Total		320.1



<p>Prov</p>	<p>1: 9.2 ↙                  2: 9.5 ↗                  3: 9.7 ↓                  4: *10.8 ↘                  5: *10.2 →                  6: 9.1 ↙                  7: *10.6 ↑                  8: *10.4 ↘                  9: 9.2 ↙                  10: 9.2 ↘</p> <p>Serie 97.9 Total 0.0</p>	<p>Prov</p>	<p>11: 7.9 ↙                  12: 10.0 ↓                  13: *10.3 ↗                  14: 9.2 ↙                  15: 10.1 ←                  16: 9.1 ↗                  17: 10.0 ↑                  18: *10.6 ↘</p> <p>Serie 77.2 Total 0.0</p>
-------------	--	-------------	--

<p>40 Skott</p>	<p>1: 8.7 ↙                  2: *10.4 ↓                  3: 10.1 ↓                  4: 10.1 ↓                  5: 9.5 ↑                  6: 8.7 →                  7: 7.1 ←                  8: *10.2 ↗                  9: 8.2 ←                  10: 9.3 ←</p> <p>Serie 92.3 Total 92.3</p>	<p>40 Skott</p>	<p>11: 9.4 ←                  12: *10.3 ↓                  13: 9.4 →                  14: 9.2 ↙                  15: *10.4 ↗                  16: *10.2 ↓                  17: 9.5 ↑                  18: 10.0 ↙                  19: 9.3 →                  20: *10.3 ↘</p> <p>Serie 98.0 Total 190.3</p>
-----------------	---	-----------------	--

<p>40 Skott</p>	<p>21: *10.5 ↘                  22: 8.9 ↙                  23: *10.2 ↘                  24: *10.3 →                  25: 9.8 ↗                  26: 9.3 →                  27: 8.1 ↓                  28: 8.8 ←                  29: 9.2 ↗                  30: 8.6 ←</p> <p>Serie 93.7 Total 284.0</p>	<p>40 Skott</p>	<p>31: 9.7 ↙                  32: 6.5 ↘                  33: 9.5 ↙                  34: 9.4 ↙                  35: 9.1 ↑                  36: *10.5 →                  37: *10.2 ↗                  38: 9.2 →                  39: *10.6 ↘                  40: 9.6 ↙</p> <p>Serie 94.3 Total 378.3</p>
-----------------	---	-----------------	---

Proov 	1: *10.8 ↘ 2: 10.1 ↗ 3: 9.7 ↘ 4: 10.0 ↖ 5: *10.3 ↘ 6: *10.5 ↘ 7: *10.5 ↘ 8: 10.1 ↘ 9: 9.3 ↖ 10: 9.7 →	Proov 	11: 10.0 ← 12: *10.5 ↗ 13: *10.4 ↗ 14: 10.1 ↑ 15: 10.0 → 16: *10.2 ↗ 17: 8.5 →
Serie	101.0	Serie	69.7
Total	0.0	Total	0.0



40 Skott 	1: *10.5 ↑ 2: *10.3 ↗ 3: 10.0 ↖ 4: *10.3 ↗ 5: 9.7 ↑ 6: *10.6 → 7: *10.2 ↘ 8: *10.5 ← 9: 10.0 ↘ 10: *10.7 ↑	40 Skott 	11: *10.6 ↘ 12: 9.9 ↖ 13: *10.6 ↘ 14: *10.4 ↘ 15: *10.6 ↘ 16: *10.6 ↘ 17: 10.1 ↑ 18: 10.0 ↑ 19: 9.8 ↗ 20: *10.4 ←
Serie	102.8	Serie	103.0
Total	102.8	Total	205.8

40 Skott 	21: *10.5 ← 22: 9.6 ↗ 23: *10.4 ↘ 24: *10.3 → 25: *10.4 ↗ 26: 10.1 ↗ 27: 10.1 ↗ 28: 9.8 → 29: 9.5 → 30: 9.6 ↗	40 Skott 	31: 9.2 → 32: 9.8 → 33: *10.3 ↘ 34: 10.0 ← 35: 9.7 ↖ 36: *10.2 ↘ 37: *10.4 ↗ 38: 9.3 → 39: *10.3 ↗ 40: 9.2 →
Serie	100.3	Serie	98.4
Total	306.1	Total	404.5

<p>Prov</p>	<p>Prov</p>
-------------	-------------

<p>40 Skott</p>	<p>40 Skott</p>
-----------------	-----------------

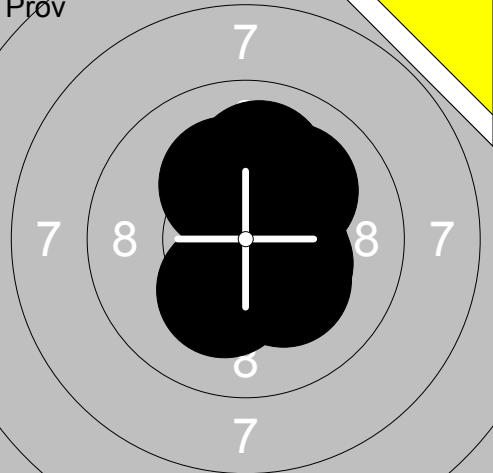
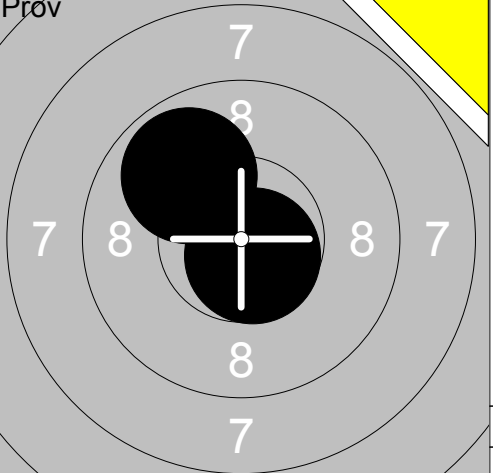
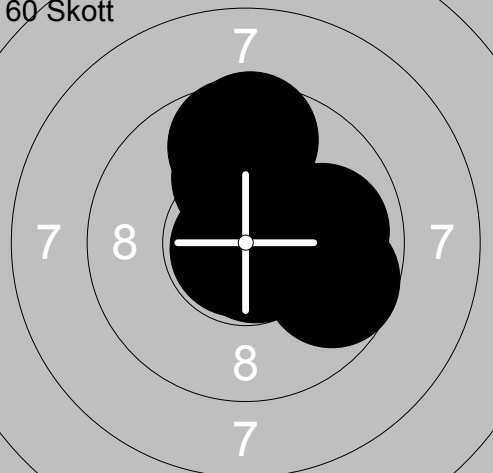
<p>40 Skott</p>	<p>40 Skott</p>
-----------------	-----------------

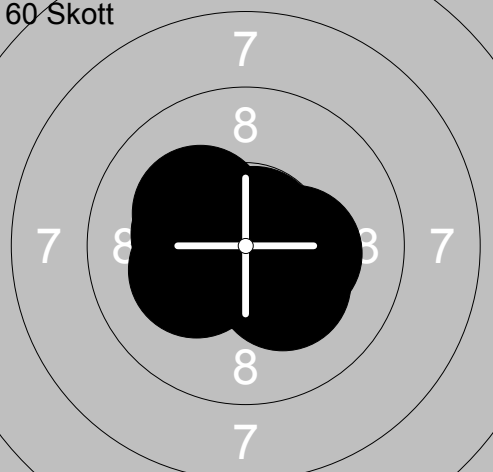
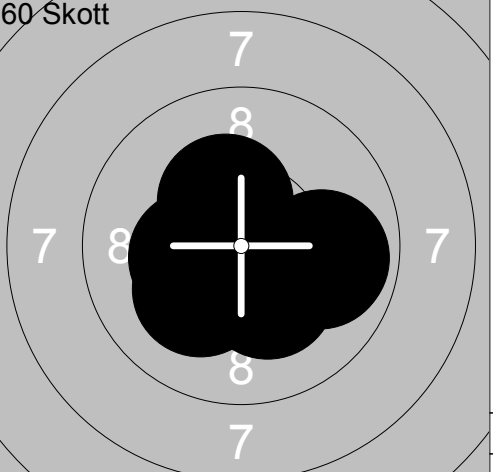
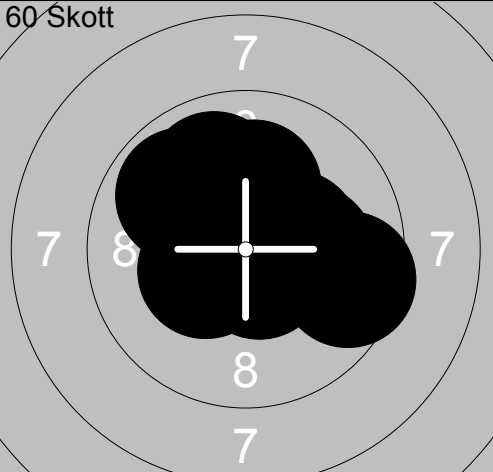
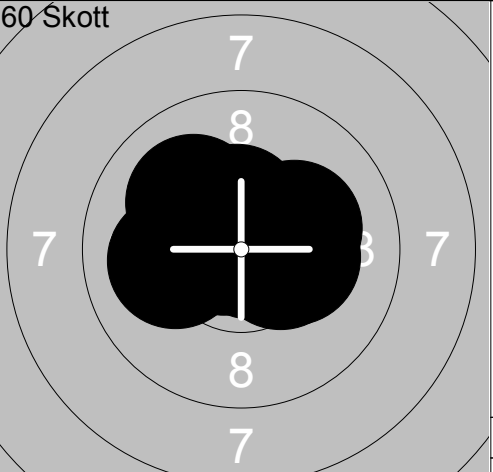
Pröv	Pröv	Pröv																								
	<table border="1" style="width:100%; border-collapse: collapse;"> <tr><td>1: *10.3</td><td>↘</td></tr> <tr><td>2: 10.1</td><td>↗</td></tr> <tr><td>3: *10.4</td><td>↗</td></tr> <tr><td>4: *10.4</td><td>↘</td></tr> <tr><td>5: *10.2</td><td>↘</td></tr> <tr><td>6: *10.2</td><td>↘</td></tr> <tr><td>7: *10.4</td><td>→</td></tr> <tr><td>8: 10.0</td><td>↑</td></tr> <tr><td>9: *10.4</td><td>↗</td></tr> <tr><td>10: *10.2</td><td>↗</td></tr> <tr><td colspan="2" style="text-align: right;">Serie 102.6</td></tr> <tr><td colspan="2" style="text-align: right;">Total 0.0</td></tr> </table>	1: *10.3	↘	2: 10.1	↗	3: *10.4	↗	4: *10.4	↘	5: *10.2	↘	6: *10.2	↘	7: *10.4	→	8: 10.0	↑	9: *10.4	↗	10: *10.2	↗	Serie 102.6		Total 0.0		
1: *10.3	↘																									
2: 10.1	↗																									
3: *10.4	↗																									
4: *10.4	↘																									
5: *10.2	↘																									
6: *10.2	↘																									
7: *10.4	→																									
8: 10.0	↑																									
9: *10.4	↗																									
10: *10.2	↗																									
Serie 102.6																										
Total 0.0																										
	<table border="1" style="width:100%; border-collapse: collapse;"> <tr><td>11: *10.7</td><td>↘</td></tr> <tr><td>12: 9.9</td><td>↗</td></tr> <tr><td colspan="2" style="text-align: right;">Serie 20.6</td></tr> <tr><td colspan="2" style="text-align: right;">Total 0.0</td></tr> </table>	11: *10.7	↘	12: 9.9	↗	Serie 20.6		Total 0.0																		
11: *10.7	↘																									
12: 9.9	↗																									
Serie 20.6																										
Total 0.0																										
<b>60 Skott</b> 	<table border="1" style="width:100%; border-collapse: collapse;"> <tr><td>1: *10.7</td><td>↘</td></tr> <tr><td>2: *10.6</td><td>↗</td></tr> <tr><td>3: *10.6</td><td>↗</td></tr> <tr><td>4: *10.8</td><td>↖</td></tr> <tr><td>5: 9.9</td><td>→</td></tr> <tr><td>6: 9.7</td><td>↑</td></tr> <tr><td>7: *10.7</td><td>↗</td></tr> <tr><td>8: 9.7</td><td>→</td></tr> <tr><td>9: 9.6</td><td>↑</td></tr> <tr><td>10: 10.1</td><td>↑</td></tr> <tr><td colspan="2" style="text-align: right;">Serie 102.4</td></tr> <tr><td colspan="2" style="text-align: right;">Total 102.4</td></tr> </table>	1: *10.7	↘	2: *10.6	↗	3: *10.6	↗	4: *10.8	↖	5: 9.9	→	6: 9.7	↑	7: *10.7	↗	8: 9.7	→	9: 9.6	↑	10: 10.1	↑	Serie 102.4		Total 102.4		<b>60 Skott</b> 
1: *10.7	↘																									
2: *10.6	↗																									
3: *10.6	↗																									
4: *10.8	↖																									
5: 9.9	→																									
6: 9.7	↑																									
7: *10.7	↗																									
8: 9.7	→																									
9: 9.6	↑																									
10: 10.1	↑																									
Serie 102.4																										
Total 102.4																										
	<table border="1" style="width:100%; border-collapse: collapse;"> <tr><td>11: 10.0</td><td>→</td></tr> <tr><td>12: 10.1</td><td>↖</td></tr> <tr><td>13: *10.3</td><td>↗</td></tr> <tr><td>14: 9.7</td><td>↑</td></tr> <tr><td>15: *10.2</td><td>↗</td></tr> <tr><td>16: 10.0</td><td>↑</td></tr> <tr><td>17: *10.8</td><td>↑</td></tr> <tr><td>18: *10.7</td><td>→</td></tr> <tr><td>19: 10.1</td><td>→</td></tr> <tr><td>20: 10.1</td><td>↖</td></tr> <tr><td colspan="2" style="text-align: right;">Serie 102.0</td></tr> <tr><td colspan="2" style="text-align: right;">Total 204.4</td></tr> </table>	11: 10.0	→	12: 10.1	↖	13: *10.3	↗	14: 9.7	↑	15: *10.2	↗	16: 10.0	↑	17: *10.8	↑	18: *10.7	→	19: 10.1	→	20: 10.1	↖	Serie 102.0		Total 204.4		
11: 10.0	→																									
12: 10.1	↖																									
13: *10.3	↗																									
14: 9.7	↑																									
15: *10.2	↗																									
16: 10.0	↑																									
17: *10.8	↑																									
18: *10.7	→																									
19: 10.1	→																									
20: 10.1	↖																									
Serie 102.0																										
Total 204.4																										
<b>60 Skott</b> 	<table border="1" style="width:100%; border-collapse: collapse;"> <tr><td>21: *10.3</td><td>↘</td></tr> <tr><td>22: *10.3</td><td>→</td></tr> <tr><td>23: *10.8</td><td>↑</td></tr> <tr><td>24: *10.3</td><td>↖</td></tr> <tr><td>25: *10.7</td><td>→</td></tr> <tr><td>26: *10.4</td><td>↗</td></tr> <tr><td>27: *10.3</td><td>↘</td></tr> <tr><td>28: *10.2</td><td>↗</td></tr> <tr><td>29: *10.2</td><td>↖</td></tr> <tr><td>30: *10.8</td><td>↗</td></tr> <tr><td colspan="2" style="text-align: right;">Serie 104.3</td></tr> <tr><td colspan="2" style="text-align: right;">Total 308.7</td></tr> </table>	21: *10.3	↘	22: *10.3	→	23: *10.8	↑	24: *10.3	↖	25: *10.7	→	26: *10.4	↗	27: *10.3	↘	28: *10.2	↗	29: *10.2	↖	30: *10.8	↗	Serie 104.3		Total 308.7		<b>60 Skott</b> 
21: *10.3	↘																									
22: *10.3	→																									
23: *10.8	↑																									
24: *10.3	↖																									
25: *10.7	→																									
26: *10.4	↗																									
27: *10.3	↘																									
28: *10.2	↗																									
29: *10.2	↖																									
30: *10.8	↗																									
Serie 104.3																										
Total 308.7																										
	<table border="1" style="width:100%; border-collapse: collapse;"> <tr><td>31: 9.9</td><td>→</td></tr> <tr><td>32: *10.3</td><td>↖</td></tr> <tr><td>33: *10.8</td><td>↖</td></tr> <tr><td>34: *10.7</td><td>↘</td></tr> <tr><td>35: *10.3</td><td>↑</td></tr> <tr><td>36: 9.9</td><td>→</td></tr> <tr><td>37: *10.5</td><td>↘</td></tr> <tr><td>38: *10.3</td><td>↘</td></tr> <tr><td>39: *10.2</td><td>↘</td></tr> <tr><td>40: *10.8</td><td>↗</td></tr> <tr><td colspan="2" style="text-align: right;">Serie 103.7</td></tr> <tr><td colspan="2" style="text-align: right;">Total 412.4</td></tr> </table>	31: 9.9	→	32: *10.3	↖	33: *10.8	↖	34: *10.7	↘	35: *10.3	↑	36: 9.9	→	37: *10.5	↘	38: *10.3	↘	39: *10.2	↘	40: *10.8	↗	Serie 103.7		Total 412.4		
31: 9.9	→																									
32: *10.3	↖																									
33: *10.8	↖																									
34: *10.7	↘																									
35: *10.3	↑																									
36: 9.9	→																									
37: *10.5	↘																									
38: *10.3	↘																									
39: *10.2	↘																									
40: *10.8	↗																									
Serie 103.7																										
Total 412.4																										
<b>60 Skott</b> 	<table border="1" style="width:100%; border-collapse: collapse;"> <tr><td>41: *10.7</td><td>↗</td></tr> <tr><td>42: 9.9</td><td>↗</td></tr> <tr><td>43: 9.5</td><td>→</td></tr> <tr><td>44: 10.1</td><td>→</td></tr> <tr><td>45: 10.1</td><td>↑</td></tr> <tr><td>46: *10.6</td><td>↘</td></tr> <tr><td>47: *10.3</td><td>→</td></tr> <tr><td>48: 9.9</td><td>↗</td></tr> <tr><td>49: *10.5</td><td>↑</td></tr> <tr><td>50: *10.4</td><td>↖</td></tr> <tr><td colspan="2" style="text-align: right;">Serie 102.0</td></tr> <tr><td colspan="2" style="text-align: right;">Total 514.4</td></tr> </table>	41: *10.7	↗	42: 9.9	↗	43: 9.5	→	44: 10.1	→	45: 10.1	↑	46: *10.6	↘	47: *10.3	→	48: 9.9	↗	49: *10.5	↑	50: *10.4	↖	Serie 102.0		Total 514.4		<b>60 Skott</b> 
41: *10.7	↗																									
42: 9.9	↗																									
43: 9.5	→																									
44: 10.1	→																									
45: 10.1	↑																									
46: *10.6	↘																									
47: *10.3	→																									
48: 9.9	↗																									
49: *10.5	↑																									
50: *10.4	↖																									
Serie 102.0																										
Total 514.4																										
	<table border="1" style="width:100%; border-collapse: collapse;"> <tr><td>51: *10.4</td><td>→</td></tr> <tr><td>52: *10.3</td><td>→</td></tr> <tr><td>53: 10.1</td><td>↖</td></tr> <tr><td>54: *10.6</td><td>↖</td></tr> <tr><td>55: *10.6</td><td>↗</td></tr> <tr><td>56: *10.8</td><td>→</td></tr> <tr><td>57: *10.5</td><td>↑</td></tr> <tr><td>58: 10.1</td><td>↗</td></tr> <tr><td>59: *10.7</td><td>↖</td></tr> <tr><td>60: *10.2</td><td>→</td></tr> <tr><td colspan="2" style="text-align: right;">Serie 104.3</td></tr> <tr><td colspan="2" style="text-align: right;">Total 618.7</td></tr> </table>	51: *10.4	→	52: *10.3	→	53: 10.1	↖	54: *10.6	↖	55: *10.6	↗	56: *10.8	→	57: *10.5	↑	58: 10.1	↗	59: *10.7	↖	60: *10.2	→	Serie 104.3		Total 618.7		
51: *10.4	→																									
52: *10.3	→																									
53: 10.1	↖																									
54: *10.6	↖																									
55: *10.6	↗																									
56: *10.8	→																									
57: *10.5	↑																									
58: 10.1	↗																									
59: *10.7	↖																									
60: *10.2	→																									
Serie 104.3																										
Total 618.7																										

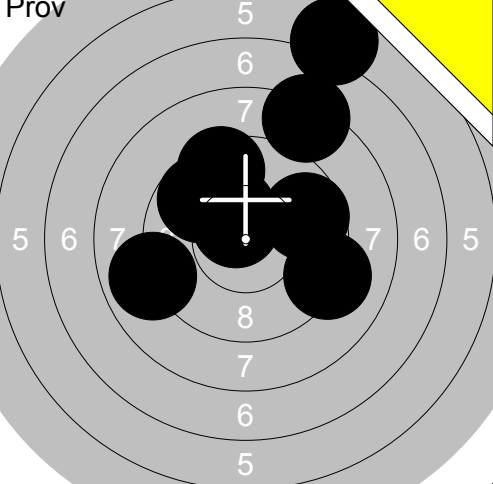
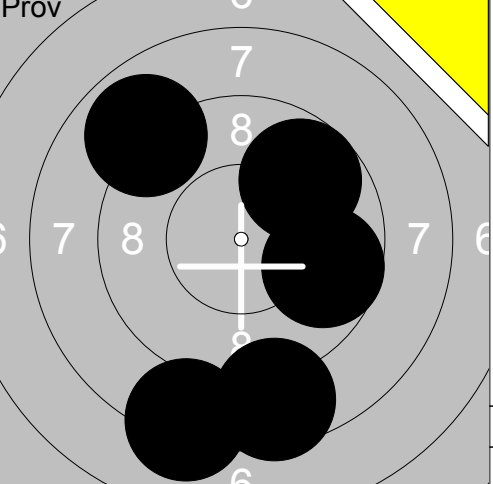
	<table border="1" style="width:100%; border-collapse: collapse;"> <tr><td>1:</td><td>8.9</td><td>←</td></tr> <tr><td>2:</td><td>9.6</td><td>→</td></tr> <tr><td>3:</td><td>9.1</td><td>→</td></tr> <tr><td>4:</td><td>*10.6</td><td>↗</td></tr> <tr><td>5:</td><td>9.7</td><td>↗</td></tr> <tr><td>6:</td><td>8.2</td><td>↗</td></tr> <tr><td>7:</td><td>9.5</td><td>↗</td></tr> <tr><td>8:</td><td>6.5</td><td>↗</td></tr> <tr><td>9:</td><td>*10.5</td><td>↗</td></tr> <tr><td>10:</td><td>*10.3</td><td>↗</td></tr> <tr><td colspan="2"><b>Serie</b></td><td><b>92.9</b></td></tr> <tr><td colspan="2"><b>Total</b></td><td><b>0.0</b></td></tr> </table>	1:	8.9	←	2:	9.6	→	3:	9.1	→	4:	*10.6	↗	5:	9.7	↗	6:	8.2	↗	7:	9.5	↗	8:	6.5	↗	9:	*10.5	↗	10:	*10.3	↗	<b>Serie</b>		<b>92.9</b>	<b>Total</b>		<b>0.0</b>		<table border="1" style="width:100%; border-collapse: collapse;"> <tr><td>11:</td><td>9.7</td><td>→</td></tr> <tr><td>12:</td><td>8.9</td><td>↗</td></tr> <tr><td>13:</td><td>8.6</td><td>↓</td></tr> <tr><td>14:</td><td>8.2</td><td>↓</td></tr> <tr><td>15:</td><td>9.7</td><td>↗</td></tr> <tr><td colspan="2"><b>Serie</b></td><td><b>45.1</b></td></tr> <tr><td colspan="2"><b>Total</b></td><td><b>0.0</b></td></tr> </table>	11:	9.7	→	12:	8.9	↗	13:	8.6	↓	14:	8.2	↓	15:	9.7	↗	<b>Serie</b>		<b>45.1</b>	<b>Total</b>		<b>0.0</b>
1:	8.9	←																																																										
2:	9.6	→																																																										
3:	9.1	→																																																										
4:	*10.6	↗																																																										
5:	9.7	↗																																																										
6:	8.2	↗																																																										
7:	9.5	↗																																																										
8:	6.5	↗																																																										
9:	*10.5	↗																																																										
10:	*10.3	↗																																																										
<b>Serie</b>		<b>92.9</b>																																																										
<b>Total</b>		<b>0.0</b>																																																										
11:	9.7	→																																																										
12:	8.9	↗																																																										
13:	8.6	↓																																																										
14:	8.2	↓																																																										
15:	9.7	↗																																																										
<b>Serie</b>		<b>45.1</b>																																																										
<b>Total</b>		<b>0.0</b>																																																										

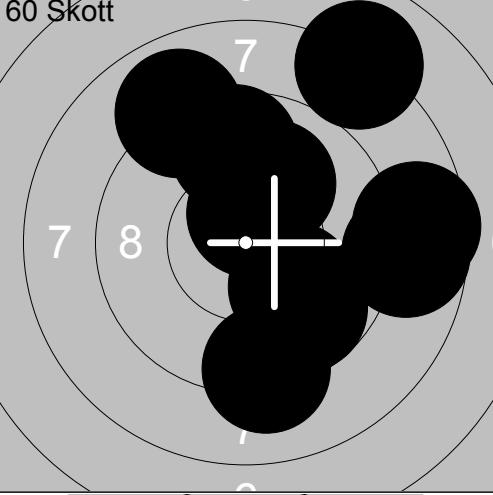
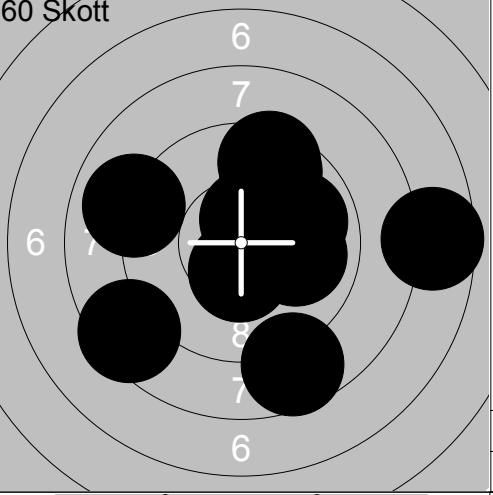
	<table border="1" style="width:100%; border-collapse: collapse;"> <tr><td>1:</td><td>9.2</td><td>↓</td></tr> <tr><td>2:</td><td>10.1</td><td>↗</td></tr> <tr><td>3:</td><td>8.6</td><td>→</td></tr> <tr><td>4:</td><td>9.6</td><td>↑</td></tr> <tr><td>5:</td><td>10.1</td><td>↘</td></tr> <tr><td>6:</td><td>8.9</td><td>↗</td></tr> <tr><td>7:</td><td>8.0</td><td>↗</td></tr> <tr><td>8:</td><td>9.7</td><td>↘</td></tr> <tr><td>9:</td><td>*10.5</td><td>↑</td></tr> <tr><td>10:</td><td>8.7</td><td>→</td></tr> <tr><td colspan="2"><b>Serie</b></td><td><b>93.4</b></td></tr> <tr><td colspan="2"><b>Total</b></td><td><b>93.4</b></td></tr> </table>	1:	9.2	↓	2:	10.1	↗	3:	8.6	→	4:	9.6	↑	5:	10.1	↘	6:	8.9	↗	7:	8.0	↗	8:	9.7	↘	9:	*10.5	↑	10:	8.7	→	<b>Serie</b>		<b>93.4</b>	<b>Total</b>		<b>93.4</b>		<table border="1" style="width:100%; border-collapse: collapse;"> <tr><td>11:</td><td>10.0</td><td>→</td></tr> <tr><td>12:</td><td>8.4</td><td>↙</td></tr> <tr><td>13:</td><td>9.6</td><td>↗</td></tr> <tr><td>14:</td><td>9.5</td><td>↗</td></tr> <tr><td>15:</td><td>9.0</td><td>↙</td></tr> <tr><td>16:</td><td>*10.5</td><td>↗</td></tr> <tr><td>17:</td><td>9.9</td><td>→</td></tr> <tr><td>18:</td><td>8.6</td><td>↓</td></tr> <tr><td>19:</td><td>*10.5</td><td>↓</td></tr> <tr><td>20:</td><td>7.6</td><td>→</td></tr> <tr><td colspan="2"><b>Serie</b></td><td><b>93.6</b></td></tr> <tr><td colspan="2"><b>Total</b></td><td><b>187.0</b></td></tr> </table>	11:	10.0	→	12:	8.4	↙	13:	9.6	↗	14:	9.5	↗	15:	9.0	↙	16:	*10.5	↗	17:	9.9	→	18:	8.6	↓	19:	*10.5	↓	20:	7.6	→	<b>Serie</b>		<b>93.6</b>	<b>Total</b>		<b>187.0</b>
1:	9.2	↓																																																																									
2:	10.1	↗																																																																									
3:	8.6	→																																																																									
4:	9.6	↑																																																																									
5:	10.1	↘																																																																									
6:	8.9	↗																																																																									
7:	8.0	↗																																																																									
8:	9.7	↘																																																																									
9:	*10.5	↑																																																																									
10:	8.7	→																																																																									
<b>Serie</b>		<b>93.4</b>																																																																									
<b>Total</b>		<b>93.4</b>																																																																									
11:	10.0	→																																																																									
12:	8.4	↙																																																																									
13:	9.6	↗																																																																									
14:	9.5	↗																																																																									
15:	9.0	↙																																																																									
16:	*10.5	↗																																																																									
17:	9.9	→																																																																									
18:	8.6	↓																																																																									
19:	*10.5	↓																																																																									
20:	7.6	→																																																																									
<b>Serie</b>		<b>93.6</b>																																																																									
<b>Total</b>		<b>187.0</b>																																																																									

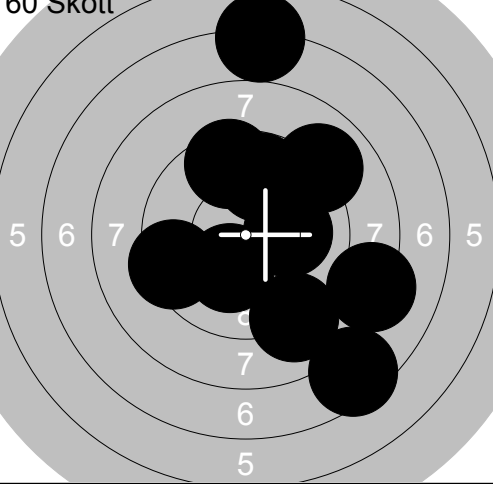
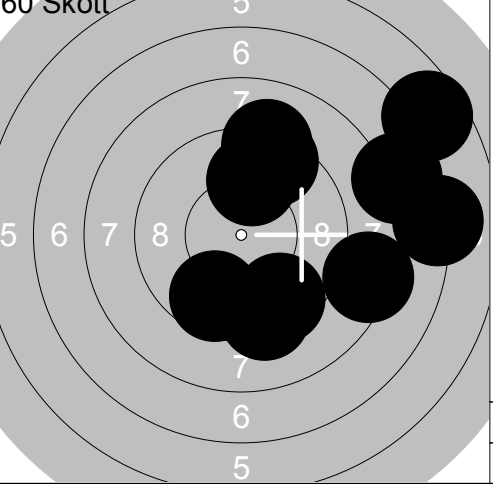
	<table border="1" style="width:100%; border-collapse: collapse;"> <tr><td>21:</td><td>8.2</td><td>→</td></tr> <tr><td>22:</td><td>9.0</td><td>↓</td></tr> <tr><td>23:</td><td>7.4</td><td>↘</td></tr> <tr><td>24:</td><td>7.0</td><td>↑</td></tr> <tr><td>25:</td><td>10.1</td><td>→</td></tr> <tr><td>26:</td><td>9.0</td><td>↗</td></tr> <tr><td>27:</td><td>9.5</td><td>↑</td></tr> <tr><td>28:</td><td>*10.2</td><td>↓</td></tr> <tr><td>29:</td><td>9.4</td><td>↙</td></tr> <tr><td>30:</td><td>9.8</td><td>↑</td></tr> <tr><td colspan="2"><b>Serie</b></td><td><b>89.6</b></td></tr> <tr><td colspan="2"><b>Total</b></td><td><b>276.6</b></td></tr> </table>	21:	8.2	→	22:	9.0	↓	23:	7.4	↘	24:	7.0	↑	25:	10.1	→	26:	9.0	↗	27:	9.5	↑	28:	*10.2	↓	29:	9.4	↙	30:	9.8	↑	<b>Serie</b>		<b>89.6</b>	<b>Total</b>		<b>276.6</b>		<table border="1" style="width:100%; border-collapse: collapse;"> <tr><td>31:</td><td>9.6</td><td>↘</td></tr> <tr><td>32:</td><td>9.3</td><td>↓</td></tr> <tr><td>33:</td><td>9.4</td><td>↗</td></tr> <tr><td>34:</td><td>9.5</td><td>↘</td></tr> <tr><td>35:</td><td>6.6</td><td>↗</td></tr> <tr><td>36:</td><td>7.7</td><td>→</td></tr> <tr><td>37:</td><td>9.9</td><td>↑</td></tr> <tr><td>38:</td><td>8.3</td><td>→</td></tr> <tr><td>39:</td><td>9.1</td><td>↑</td></tr> <tr><td>40:</td><td>7.1</td><td>→</td></tr> <tr><td colspan="2"><b>Serie</b></td><td><b>86.5</b></td></tr> <tr><td colspan="2"><b>Total</b></td><td><b>363.1</b></td></tr> </table>	31:	9.6	↘	32:	9.3	↓	33:	9.4	↗	34:	9.5	↘	35:	6.6	↗	36:	7.7	→	37:	9.9	↑	38:	8.3	→	39:	9.1	↑	40:	7.1	→	<b>Serie</b>		<b>86.5</b>	<b>Total</b>		<b>363.1</b>
21:	8.2	→																																																																									
22:	9.0	↓																																																																									
23:	7.4	↘																																																																									
24:	7.0	↑																																																																									
25:	10.1	→																																																																									
26:	9.0	↗																																																																									
27:	9.5	↑																																																																									
28:	*10.2	↓																																																																									
29:	9.4	↙																																																																									
30:	9.8	↑																																																																									
<b>Serie</b>		<b>89.6</b>																																																																									
<b>Total</b>		<b>276.6</b>																																																																									
31:	9.6	↘																																																																									
32:	9.3	↓																																																																									
33:	9.4	↗																																																																									
34:	9.5	↘																																																																									
35:	6.6	↗																																																																									
36:	7.7	→																																																																									
37:	9.9	↑																																																																									
38:	8.3	→																																																																									
39:	9.1	↑																																																																									
40:	7.1	→																																																																									
<b>Serie</b>		<b>86.5</b>																																																																									
<b>Total</b>		<b>363.1</b>																																																																									

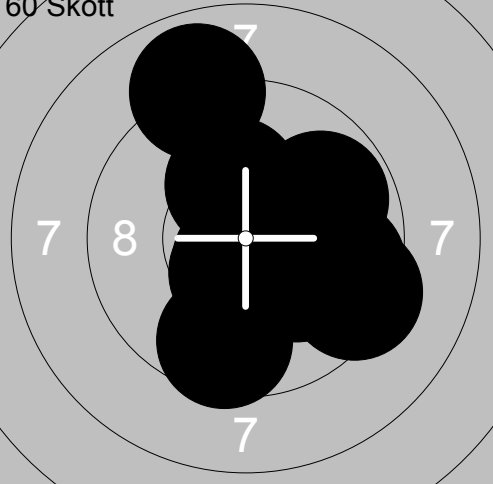
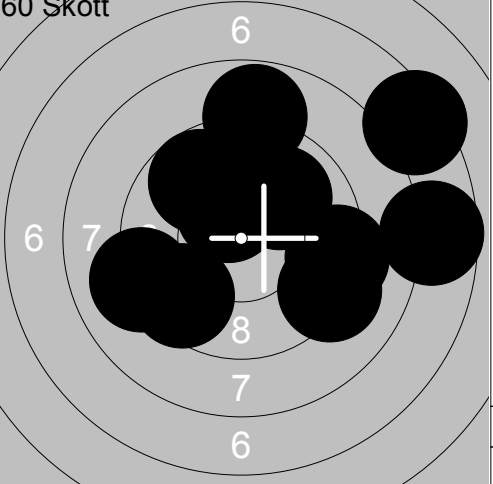
	<table border="1" style="width:100%; border-collapse: collapse;"> <tr><td>41:</td><td>*10.6</td><td>↓</td></tr> <tr><td>42:</td><td>*10.5</td><td>↓</td></tr> <tr><td>43:</td><td>*10.7</td><td>→</td></tr> <tr><td>44:</td><td>10.1</td><td>↘</td></tr> <tr><td>45:</td><td>8.9</td><td>↗</td></tr> <tr><td>46:</td><td>9.8</td><td>↗</td></tr> <tr><td>47:</td><td>9.7</td><td>→</td></tr> <tr><td>48:</td><td>*10.2</td><td>↑</td></tr> <tr><td>49:</td><td>9.3</td><td>↘</td></tr> <tr><td>50:</td><td>9.6</td><td>↓</td></tr> <tr><td colspan="2"><b>Serie</b></td><td><b>99.4</b></td></tr> <tr><td colspan="2"><b>Total</b></td><td><b>462.5</b></td></tr> </table>	41:	*10.6	↓	42:	*10.5	↓	43:	*10.7	→	44:	10.1	↘	45:	8.9	↗	46:	9.8	↗	47:	9.7	→	48:	*10.2	↑	49:	9.3	↘	50:	9.6	↓	<b>Serie</b>		<b>99.4</b>	<b>Total</b>		<b>462.5</b>		<table border="1" style="width:100%; border-collapse: collapse;"> <tr><td>51:</td><td>9.2</td><td>↘</td></tr> <tr><td>52:</td><td>9.3</td><td>→</td></tr> <tr><td>53:</td><td>7.3</td><td>↗</td></tr> <tr><td>54:</td><td>9.1</td><td>↙</td></tr> <tr><td>55:</td><td>8.8</td><td>↑</td></tr> <tr><td>56:</td><td>9.7</td><td>↗</td></tr> <tr><td>57:</td><td>7.6</td><td>→</td></tr> <tr><td>58:</td><td>10.0</td><td>↗</td></tr> <tr><td>59:</td><td>9.5</td><td>↙</td></tr> <tr><td>60:</td><td>*10.4</td><td>↗</td></tr> <tr><td colspan="2"><b>Serie</b></td><td><b>90.9</b></td></tr> <tr><td colspan="2"><b>Total</b></td><td><b>553.4</b></td></tr> </table>	51:	9.2	↘	52:	9.3	→	53:	7.3	↗	54:	9.1	↙	55:	8.8	↑	56:	9.7	↗	57:	7.6	→	58:	10.0	↗	59:	9.5	↙	60:	*10.4	↗	<b>Serie</b>		<b>90.9</b>	<b>Total</b>		<b>553.4</b>
41:	*10.6	↓																																																																									
42:	*10.5	↓																																																																									
43:	*10.7	→																																																																									
44:	10.1	↘																																																																									
45:	8.9	↗																																																																									
46:	9.8	↗																																																																									
47:	9.7	→																																																																									
48:	*10.2	↑																																																																									
49:	9.3	↘																																																																									
50:	9.6	↓																																																																									
<b>Serie</b>		<b>99.4</b>																																																																									
<b>Total</b>		<b>462.5</b>																																																																									
51:	9.2	↘																																																																									
52:	9.3	→																																																																									
53:	7.3	↗																																																																									
54:	9.1	↙																																																																									
55:	8.8	↑																																																																									
56:	9.7	↗																																																																									
57:	7.6	→																																																																									
58:	10.0	↗																																																																									
59:	9.5	↙																																																																									
60:	*10.4	↗																																																																									
<b>Serie</b>		<b>90.9</b>																																																																									
<b>Total</b>		<b>553.4</b>																																																																									

<p>Pröv</p>	<table border="1" style="width:100%; border-collapse: collapse;"> <tr><td>1:</td><td>8.5</td><td>↖</td></tr> <tr><td>2:</td><td>6.4</td><td>←</td></tr> <tr><td>3:</td><td>9.2</td><td>←</td></tr> <tr><td>4:</td><td>7.9</td><td>←</td></tr> <tr><td>5:</td><td>9.5</td><td>↗</td></tr> <tr><td>6:</td><td>9.8</td><td>↑</td></tr> <tr><td>7:</td><td>9.2</td><td>↓</td></tr> <tr><td>8:</td><td>8.5</td><td>←</td></tr> <tr><td>9:</td><td>9.8</td><td>↓</td></tr> <tr><td>10:</td><td>9.1</td><td>↓</td></tr> <tr><td colspan="2">Serie</td><td>87.9</td></tr> <tr><td colspan="2">Total</td><td>0.0</td></tr> </table>	1:	8.5	↖	2:	6.4	←	3:	9.2	←	4:	7.9	←	5:	9.5	↗	6:	9.8	↑	7:	9.2	↓	8:	8.5	←	9:	9.8	↓	10:	9.1	↓	Serie		87.9	Total		0.0	<p>Pröv</p>	<table border="1" style="width:100%; border-collapse: collapse;"> <tr><td>11:</td><td>9.8</td><td>→</td></tr> <tr><td colspan="2">Serie</td><td>9.8</td></tr> <tr><td colspan="2">Total</td><td>0.0</td></tr> </table>	11:	9.8	→	Serie		9.8	Total		0.0
1:	8.5	↖																																														
2:	6.4	←																																														
3:	9.2	←																																														
4:	7.9	←																																														
5:	9.5	↗																																														
6:	9.8	↑																																														
7:	9.2	↓																																														
8:	8.5	←																																														
9:	9.8	↓																																														
10:	9.1	↓																																														
Serie		87.9																																														
Total		0.0																																														
11:	9.8	→																																														
Serie		9.8																																														
Total		0.0																																														

<p>60 Skott</p>	<table border="1" style="width:100%; border-collapse: collapse;"> <tr><td>1:</td><td>9.6</td><td>→</td></tr> <tr><td>2:</td><td>10.0</td><td>↓</td></tr> <tr><td>3:</td><td>8.6</td><td>↖</td></tr> <tr><td>4:</td><td>9.9</td><td>↓</td></tr> <tr><td>5:</td><td>8.0</td><td>←</td></tr> <tr><td>6:</td><td>9.3</td><td>↖</td></tr> <tr><td>7:</td><td>9.6</td><td>↓</td></tr> <tr><td>8:</td><td>9.0</td><td>↓</td></tr> <tr><td>9:</td><td>8.2</td><td>←</td></tr> <tr><td>10:</td><td>9.7</td><td>↓</td></tr> <tr><td colspan="2">Serie</td><td>91.9</td></tr> <tr><td colspan="2">Total</td><td>91.9</td></tr> </table>	1:	9.6	→	2:	10.0	↓	3:	8.6	↖	4:	9.9	↓	5:	8.0	←	6:	9.3	↖	7:	9.6	↓	8:	9.0	↓	9:	8.2	←	10:	9.7	↓	Serie		91.9	Total		91.9	<p>60 Skott</p>	<table border="1" style="width:100%; border-collapse: collapse;"> <tr><td>11:</td><td>*10.8</td><td>←</td></tr> <tr><td>12:</td><td>8.6</td><td>↗</td></tr> <tr><td>13:</td><td>9.9</td><td>↓</td></tr> <tr><td>14:</td><td>8.4</td><td>↖</td></tr> <tr><td>15:</td><td>8.5</td><td>↖</td></tr> <tr><td>16:</td><td>*10.6</td><td>↓</td></tr> <tr><td>17:</td><td>9.9</td><td>←</td></tr> <tr><td>18:</td><td>*10.8</td><td>↗</td></tr> <tr><td>19:</td><td>10.0</td><td>←</td></tr> <tr><td>20:</td><td>9.8</td><td>↓</td></tr> <tr><td colspan="2">Serie</td><td>97.3</td></tr> <tr><td colspan="2">Total</td><td>189.2</td></tr> </table>	11:	*10.8	←	12:	8.6	↗	13:	9.9	↓	14:	8.4	↖	15:	8.5	↖	16:	*10.6	↓	17:	9.9	←	18:	*10.8	↗	19:	10.0	←	20:	9.8	↓	Serie		97.3	Total		189.2
1:	9.6	→																																																																									
2:	10.0	↓																																																																									
3:	8.6	↖																																																																									
4:	9.9	↓																																																																									
5:	8.0	←																																																																									
6:	9.3	↖																																																																									
7:	9.6	↓																																																																									
8:	9.0	↓																																																																									
9:	8.2	←																																																																									
10:	9.7	↓																																																																									
Serie		91.9																																																																									
Total		91.9																																																																									
11:	*10.8	←																																																																									
12:	8.6	↗																																																																									
13:	9.9	↓																																																																									
14:	8.4	↖																																																																									
15:	8.5	↖																																																																									
16:	*10.6	↓																																																																									
17:	9.9	←																																																																									
18:	*10.8	↗																																																																									
19:	10.0	←																																																																									
20:	9.8	↓																																																																									
Serie		97.3																																																																									
Total		189.2																																																																									

<p>60 Skott</p>	<table border="1" style="width:100%; border-collapse: collapse;"> <tr><td>21:</td><td>9.9</td><td>→</td></tr> <tr><td>22:</td><td>8.2</td><td>←</td></tr> <tr><td>23:</td><td>7.9</td><td>←</td></tr> <tr><td>24:</td><td>9.8</td><td>↗</td></tr> <tr><td>25:</td><td>7.4</td><td>←</td></tr> <tr><td>26:</td><td>7.9</td><td>→</td></tr> <tr><td>27:</td><td>9.2</td><td>↓</td></tr> <tr><td>28:</td><td>10.0</td><td>↓</td></tr> <tr><td>29:</td><td>9.8</td><td>↗</td></tr> <tr><td>30:</td><td>8.5</td><td>←</td></tr> <tr><td colspan="2">Serie</td><td>88.6</td></tr> <tr><td colspan="2">Total</td><td>277.8</td></tr> </table>	21:	9.9	→	22:	8.2	←	23:	7.9	←	24:	9.8	↗	25:	7.4	←	26:	7.9	→	27:	9.2	↓	28:	10.0	↓	29:	9.8	↗	30:	8.5	←	Serie		88.6	Total		277.8	<p>60 Skott</p>	<table border="1" style="width:100%; border-collapse: collapse;"> <tr><td>31:</td><td>7.6</td><td>↓</td></tr> <tr><td>32:</td><td>9.1</td><td>↓</td></tr> <tr><td>33:</td><td>*10.4</td><td>→</td></tr> <tr><td>34:</td><td>9.1</td><td>←</td></tr> <tr><td>35:</td><td>9.9</td><td>↓</td></tr> <tr><td>36:</td><td>*10.2</td><td>↓</td></tr> <tr><td>37:</td><td>9.5</td><td>←</td></tr> <tr><td>38:</td><td>7.5</td><td>←</td></tr> <tr><td>39:</td><td>9.5</td><td>↓</td></tr> <tr><td>40:</td><td>8.9</td><td>↘</td></tr> <tr><td colspan="2">Serie</td><td>91.7</td></tr> <tr><td colspan="2">Total</td><td>369.5</td></tr> </table>	31:	7.6	↓	32:	9.1	↓	33:	*10.4	→	34:	9.1	←	35:	9.9	↓	36:	*10.2	↓	37:	9.5	←	38:	7.5	←	39:	9.5	↓	40:	8.9	↘	Serie		91.7	Total		369.5
21:	9.9	→																																																																									
22:	8.2	←																																																																									
23:	7.9	←																																																																									
24:	9.8	↗																																																																									
25:	7.4	←																																																																									
26:	7.9	→																																																																									
27:	9.2	↓																																																																									
28:	10.0	↓																																																																									
29:	9.8	↗																																																																									
30:	8.5	←																																																																									
Serie		88.6																																																																									
Total		277.8																																																																									
31:	7.6	↓																																																																									
32:	9.1	↓																																																																									
33:	*10.4	→																																																																									
34:	9.1	←																																																																									
35:	9.9	↓																																																																									
36:	*10.2	↓																																																																									
37:	9.5	←																																																																									
38:	7.5	←																																																																									
39:	9.5	↓																																																																									
40:	8.9	↘																																																																									
Serie		91.7																																																																									
Total		369.5																																																																									

<p>60 Skott</p>	<table border="1" style="width:100%; border-collapse: collapse;"> <tr><td>41:</td><td>9.7</td><td>↖</td></tr> <tr><td>42:</td><td>10.1</td><td>↓</td></tr> <tr><td>43:</td><td>8.0</td><td>←</td></tr> <tr><td>44:</td><td>9.8</td><td>←</td></tr> <tr><td>45:</td><td>9.3</td><td>↓</td></tr> <tr><td>46:</td><td>*10.2</td><td>↓</td></tr> <tr><td>47:</td><td>9.6</td><td>↓</td></tr> <tr><td>48:</td><td>10.0</td><td>←</td></tr> <tr><td>49:</td><td>9.3</td><td>←</td></tr> <tr><td>50:</td><td>9.3</td><td>←</td></tr> <tr><td colspan="2">Serie</td><td>95.3</td></tr> <tr><td colspan="2">Total</td><td>464.8</td></tr> </table>	41:	9.7	↖	42:	10.1	↓	43:	8.0	←	44:	9.8	←	45:	9.3	↓	46:	*10.2	↓	47:	9.6	↓	48:	10.0	←	49:	9.3	←	50:	9.3	←	Serie		95.3	Total		464.8	<p>60 Skott</p>	<table border="1" style="width:100%; border-collapse: collapse;"> <tr><td>51:</td><td>9.6</td><td>↖</td></tr> <tr><td>52:</td><td>9.5</td><td>↖</td></tr> <tr><td>53:</td><td>9.2</td><td>↗</td></tr> <tr><td>54:</td><td>9.6</td><td>↓</td></tr> <tr><td>55:</td><td>*10.8</td><td>↗</td></tr> <tr><td>56:</td><td>9.0</td><td>↓</td></tr> <tr><td>57:</td><td>8.9</td><td>→</td></tr> <tr><td>58:</td><td>9.6</td><td>↓</td></tr> <tr><td>59:</td><td>9.0</td><td>↓</td></tr> <tr><td>60:</td><td>8.7</td><td>↗</td></tr> <tr><td colspan="2">Serie</td><td>93.9</td></tr> <tr><td colspan="2">Total</td><td>558.7</td></tr> </table>	51:	9.6	↖	52:	9.5	↖	53:	9.2	↗	54:	9.6	↓	55:	*10.8	↗	56:	9.0	↓	57:	8.9	→	58:	9.6	↓	59:	9.0	↓	60:	8.7	↗	Serie		93.9	Total		558.7
41:	9.7	↖																																																																									
42:	10.1	↓																																																																									
43:	8.0	←																																																																									
44:	9.8	←																																																																									
45:	9.3	↓																																																																									
46:	*10.2	↓																																																																									
47:	9.6	↓																																																																									
48:	10.0	←																																																																									
49:	9.3	←																																																																									
50:	9.3	←																																																																									
Serie		95.3																																																																									
Total		464.8																																																																									
51:	9.6	↖																																																																									
52:	9.5	↖																																																																									
53:	9.2	↗																																																																									
54:	9.6	↓																																																																									
55:	*10.8	↗																																																																									
56:	9.0	↓																																																																									
57:	8.9	→																																																																									
58:	9.6	↓																																																																									
59:	9.0	↓																																																																									
60:	8.7	↗																																																																									
Serie		93.9																																																																									
Total		558.7																																																																									



<p>Pröv</p>	<table border="1" style="width:100%; border-collapse: collapse;"> <tr><td>1:</td><td>9.6</td><td>↗</td></tr> <tr><td>2:</td><td>9.8</td><td>↘</td></tr> <tr><td>3:</td><td>9.6</td><td>→</td></tr> <tr><td>4:</td><td>9.8</td><td>↗</td></tr> <tr><td>5:</td><td>*10.9</td><td>→</td></tr> <tr><td>6:</td><td>9.3</td><td>→</td></tr> <tr><td>7:</td><td>9.0</td><td>↗</td></tr> <tr><td>8:</td><td>9.7</td><td>↑</td></tr> <tr><td>9:</td><td>8.6</td><td>→</td></tr> <tr><td>10:</td><td>9.4</td><td>↑</td></tr> <tr><td colspan="2">Serie</td><td>95.7</td></tr> <tr><td colspan="2">Total</td><td>0.0</td></tr> </table>	1:	9.6	↗	2:	9.8	↘	3:	9.6	→	4:	9.8	↗	5:	*10.9	→	6:	9.3	→	7:	9.0	↗	8:	9.7	↑	9:	8.6	→	10:	9.4	↑	Serie		95.7	Total		0.0	<p>Pröv</p>	<table border="1" style="width:100%; border-collapse: collapse;"> <tr><td>11:</td><td>8.1</td><td>↗</td></tr> <tr><td>12:</td><td>*10.5</td><td>↑</td></tr> <tr><td>13:</td><td>9.3</td><td>→</td></tr> <tr><td>14:</td><td>9.9</td><td>↗</td></tr> <tr><td>15:</td><td>*10.5</td><td>↘</td></tr> <tr><td>16:</td><td>9.7</td><td>↗</td></tr> <tr><td>17:</td><td>*10.5</td><td>↘</td></tr> <tr><td>18:</td><td>8.4</td><td>↗</td></tr> <tr><td>19:</td><td>7.5</td><td>↘</td></tr> <tr><td>20:</td><td>10.1</td><td>↗</td></tr> <tr><td colspan="2">Serie</td><td>94.5</td></tr> <tr><td colspan="2">Total</td><td>0.0</td></tr> </table>	11:	8.1	↗	12:	*10.5	↑	13:	9.3	→	14:	9.9	↗	15:	*10.5	↘	16:	9.7	↗	17:	*10.5	↘	18:	8.4	↗	19:	7.5	↘	20:	10.1	↗	Serie		94.5	Total		0.0
1:	9.6	↗																																																																									
2:	9.8	↘																																																																									
3:	9.6	→																																																																									
4:	9.8	↗																																																																									
5:	*10.9	→																																																																									
6:	9.3	→																																																																									
7:	9.0	↗																																																																									
8:	9.7	↑																																																																									
9:	8.6	→																																																																									
10:	9.4	↑																																																																									
Serie		95.7																																																																									
Total		0.0																																																																									
11:	8.1	↗																																																																									
12:	*10.5	↑																																																																									
13:	9.3	→																																																																									
14:	9.9	↗																																																																									
15:	*10.5	↘																																																																									
16:	9.7	↗																																																																									
17:	*10.5	↘																																																																									
18:	8.4	↗																																																																									
19:	7.5	↘																																																																									
20:	10.1	↗																																																																									
Serie		94.5																																																																									
Total		0.0																																																																									

<p>Pröv</p>	<table border="1" style="width:100%; border-collapse: collapse;"> <tr><td>21:</td><td>9.5</td><td>↖</td></tr> <tr><td>22:</td><td>10.1</td><td>↖</td></tr> <tr><td colspan="2">Serie</td><td>19.6</td></tr> <tr><td colspan="2">Total</td><td>0.0</td></tr> </table>	21:	9.5	↖	22:	10.1	↖	Serie		19.6	Total		0.0	<p>40 Skott</p>	<table border="1" style="width:100%; border-collapse: collapse;"> <tr><td>1:</td><td>*10.5</td><td>↘</td></tr> <tr><td>2:</td><td>9.1</td><td>→</td></tr> <tr><td>3:</td><td>8.0</td><td>↘</td></tr> <tr><td>4:</td><td>9.7</td><td>→</td></tr> <tr><td>5:</td><td>10.1</td><td>↘</td></tr> <tr><td>6:</td><td>9.1</td><td>↘</td></tr> <tr><td>7:</td><td>9.5</td><td>↖</td></tr> <tr><td>8:</td><td>9.0</td><td>↘</td></tr> <tr><td>9:</td><td>9.0</td><td>↖</td></tr> <tr><td>10:</td><td>8.7</td><td>↘</td></tr> <tr><td colspan="2">Serie</td><td>92.7</td></tr> <tr><td colspan="2">Total</td><td>92.7</td></tr> </table>	1:	*10.5	↘	2:	9.1	→	3:	8.0	↘	4:	9.7	→	5:	10.1	↘	6:	9.1	↘	7:	9.5	↖	8:	9.0	↘	9:	9.0	↖	10:	8.7	↘	Serie		92.7	Total		92.7
21:	9.5	↖																																																	
22:	10.1	↖																																																	
Serie		19.6																																																	
Total		0.0																																																	
1:	*10.5	↘																																																	
2:	9.1	→																																																	
3:	8.0	↘																																																	
4:	9.7	→																																																	
5:	10.1	↘																																																	
6:	9.1	↘																																																	
7:	9.5	↖																																																	
8:	9.0	↘																																																	
9:	9.0	↖																																																	
10:	8.7	↘																																																	
Serie		92.7																																																	
Total		92.7																																																	

<p>40 Skott</p>	<table border="1" style="width:100%; border-collapse: collapse;"> <tr><td>11:</td><td>9.2</td><td>→</td></tr> <tr><td>12:</td><td>9.3</td><td>↗</td></tr> <tr><td>13:</td><td>7.1</td><td>↖</td></tr> <tr><td>14:</td><td>9.9</td><td>↘</td></tr> <tr><td>15:</td><td>9.9</td><td>↘</td></tr> <tr><td>16:</td><td>*10.5</td><td>↘</td></tr> <tr><td>17:</td><td>9.3</td><td>↗</td></tr> <tr><td>18:</td><td>*10.3</td><td>↑</td></tr> <tr><td>19:</td><td>10.1</td><td>↖</td></tr> <tr><td>20:</td><td>9.3</td><td>→</td></tr> <tr><td colspan="2">Serie</td><td>94.9</td></tr> <tr><td colspan="2">Total</td><td>187.6</td></tr> </table>	11:	9.2	→	12:	9.3	↗	13:	7.1	↖	14:	9.9	↘	15:	9.9	↘	16:	*10.5	↘	17:	9.3	↗	18:	*10.3	↑	19:	10.1	↖	20:	9.3	→	Serie		94.9	Total		187.6	<p>40 Skott</p>	<table border="1" style="width:100%; border-collapse: collapse;"> <tr><td>21:</td><td>*10.2</td><td>↗</td></tr> <tr><td>22:</td><td>*10.5</td><td>→</td></tr> <tr><td>23:</td><td>9.5</td><td>↖</td></tr> <tr><td>24:</td><td>9.8</td><td>↖</td></tr> <tr><td>25:</td><td>8.6</td><td>↘</td></tr> <tr><td>26:</td><td>*10.3</td><td>↖</td></tr> <tr><td>27:</td><td>9.6</td><td>↖</td></tr> <tr><td>28:</td><td>9.8</td><td>↘</td></tr> <tr><td>29:</td><td>7.3</td><td>↖</td></tr> <tr><td>30:</td><td>9.0</td><td>↖</td></tr> <tr><td colspan="2">Serie</td><td>94.6</td></tr> <tr><td colspan="2">Total</td><td>282.2</td></tr> </table>	21:	*10.2	↗	22:	*10.5	→	23:	9.5	↖	24:	9.8	↖	25:	8.6	↘	26:	*10.3	↖	27:	9.6	↖	28:	9.8	↘	29:	7.3	↖	30:	9.0	↖	Serie		94.6	Total		282.2
11:	9.2	→																																																																									
12:	9.3	↗																																																																									
13:	7.1	↖																																																																									
14:	9.9	↘																																																																									
15:	9.9	↘																																																																									
16:	*10.5	↘																																																																									
17:	9.3	↗																																																																									
18:	*10.3	↑																																																																									
19:	10.1	↖																																																																									
20:	9.3	→																																																																									
Serie		94.9																																																																									
Total		187.6																																																																									
21:	*10.2	↗																																																																									
22:	*10.5	→																																																																									
23:	9.5	↖																																																																									
24:	9.8	↖																																																																									
25:	8.6	↘																																																																									
26:	*10.3	↖																																																																									
27:	9.6	↖																																																																									
28:	9.8	↘																																																																									
29:	7.3	↖																																																																									
30:	9.0	↖																																																																									
Serie		94.6																																																																									
Total		282.2																																																																									

<p>40 Skott</p>	<table border="1" style="width:100%; border-collapse: collapse;"> <tr><td>31:</td><td>*10.2</td><td>↘</td></tr> <tr><td>32:</td><td>9.4</td><td>↗</td></tr> <tr><td>33:</td><td>*10.2</td><td>↖</td></tr> <tr><td>34:</td><td>10.0</td><td>↗</td></tr> <tr><td>35:</td><td>*10.3</td><td>↖</td></tr> <tr><td>36:</td><td>8.9</td><td>↘</td></tr> <tr><td>37:</td><td>9.0</td><td>↖</td></tr> <tr><td>38:</td><td>*10.4</td><td>↖</td></tr> <tr><td>39:</td><td>9.3</td><td>↖</td></tr> <tr><td>40:</td><td>10.1</td><td>↘</td></tr> <tr><td colspan="2">Serie</td><td>97.8</td></tr> <tr><td colspan="2">Total</td><td>380.0</td></tr> </table>	31:	*10.2	↘	32:	9.4	↗	33:	*10.2	↖	34:	10.0	↗	35:	*10.3	↖	36:	8.9	↘	37:	9.0	↖	38:	*10.4	↖	39:	9.3	↖	40:	10.1	↘	Serie		97.8	Total		380.0		
31:	*10.2	↘																																					
32:	9.4	↗																																					
33:	*10.2	↖																																					
34:	10.0	↗																																					
35:	*10.3	↖																																					
36:	8.9	↘																																					
37:	9.0	↖																																					
38:	*10.4	↖																																					
39:	9.3	↖																																					
40:	10.1	↘																																					
Serie		97.8																																					
Total		380.0																																					

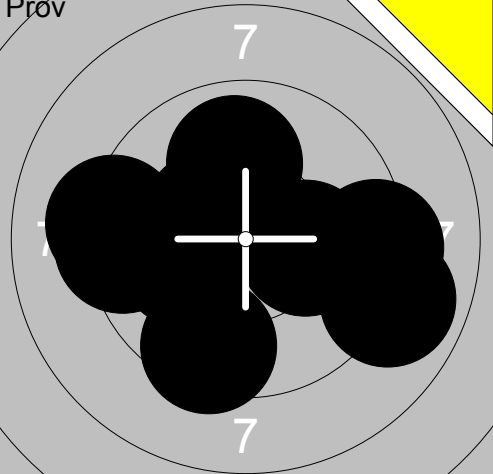
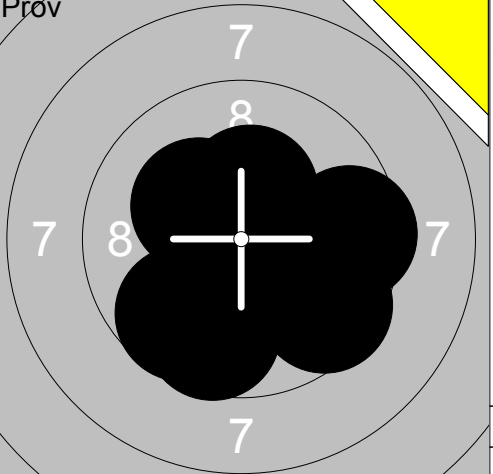

<p><b>Pröv</b></p> 	<p>1: 9.2 → 2: 8.9 → 3: 9.5 ↓ 4: 9.2 ← 5: *10.4 ↑ 6: 9.3 ← 7: *10.4 ↗ 8: *10.2 → 9: 9.9 ↑ 10: 10.1 ←</p> <p>Serie 97.1 Total 0.0</p>	<p><b>Pröv</b></p> 	<p>11: *10.2 ↓ 12: *10.3 ↑ 13: 9.6 ↓ 14: 9.5 → 15: 9.7 ↓ 16: *10.7 → 17: *10.2 ↗ 18: 9.8 ↓ 19: 9.7 ↓</p> <p>Serie 89.7 Total 0.0</p>
---	--	---	--

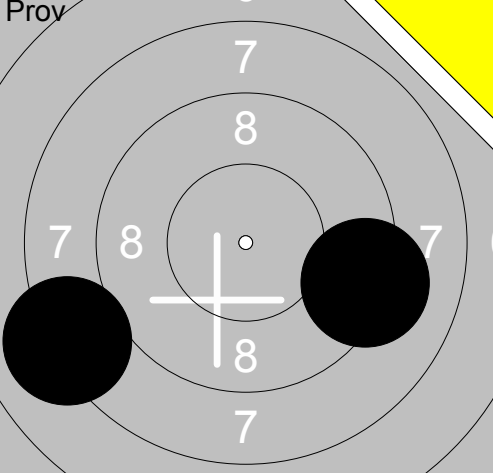
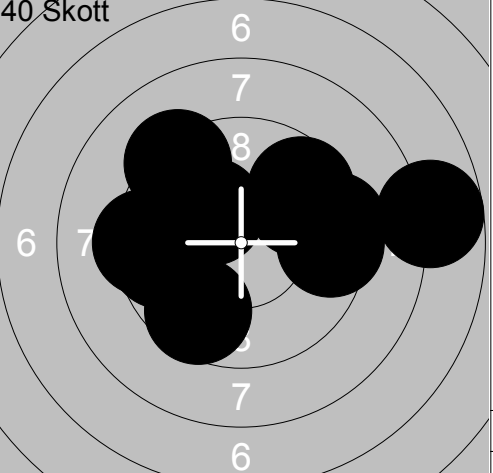
<p><b>Pröv</b></p> 	<p>21: 8.1 ← 22: 9.2 →</p> <p>Serie 17.3 Total 0.0</p>	<p><b>40 Skott</b></p> 	<p>1: 9.4 ← 2: *10.2 ↗ 3: 9.4 → 4: 9.5 → 5: 9.6 ↓ 6: 9.6 ← 7: 9.6 ↗ 8: 7.7 → 9: 9.8 ↗ 10: 9.2 ↗</p> <p>Serie 94.0 Total 94.0</p>
--	--	--	--

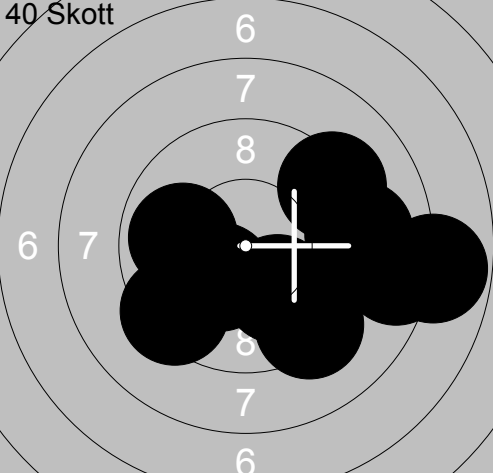
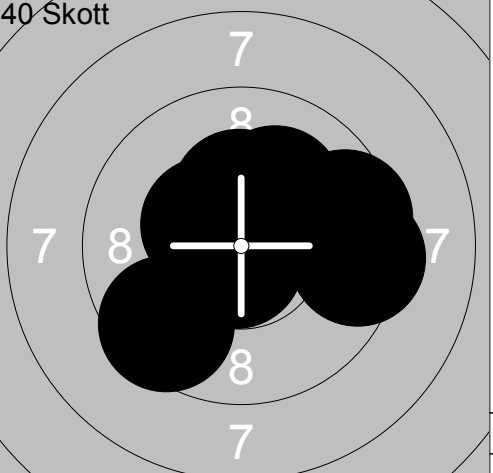
<p><b>40 Skott</b></p> 	<p>11: 9.2 ↗ 12: 9.9 ← 13: 8.4 → 14: *10.3 ↓ 15: 9.3 ↓ 16: 9.4 ← 17: 10.1 ↓ 18: 9.1 → 19: 7.8 → 20: 9.1 →</p> <p>Serie 92.6 Total 186.6</p>	<p><b>40 Skott</b></p> 	<p>21: 9.5 ↓ 22: 9.4 → 23: *10.7 ↓ 24: *10.6 ↗ 25: 10.1 ↗ 26: 9.5 → 27: *10.3 ↑ 28: *10.4 ↗ 29: *10.7 ↗ 30: *10.8 ↗</p> <p>Serie 102.0 Total 288.6</p>
---	---	---	--

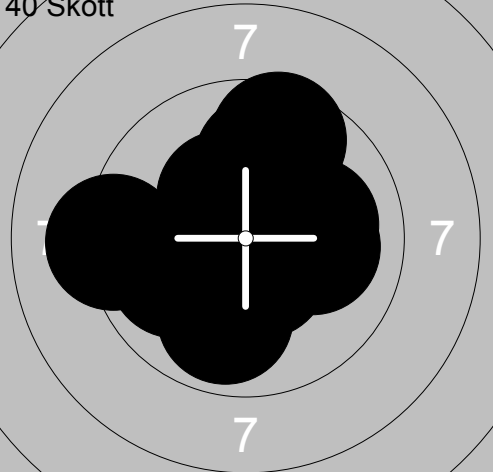
<p><b>40 Skott</b></p> 	<p>31: *10.5 ↓ 32: 9.9 ↓ 33: 9.9 ← 34: 10.1 → 35: 9.2 ← 36: *10.4 ↗ 37: *10.9 ↗ 38: 9.9 ↑ 39: 9.6 ↑ 40: 10.1 →</p> <p>Serie 100.5 Total 389.1</p>		
---	---	--	--

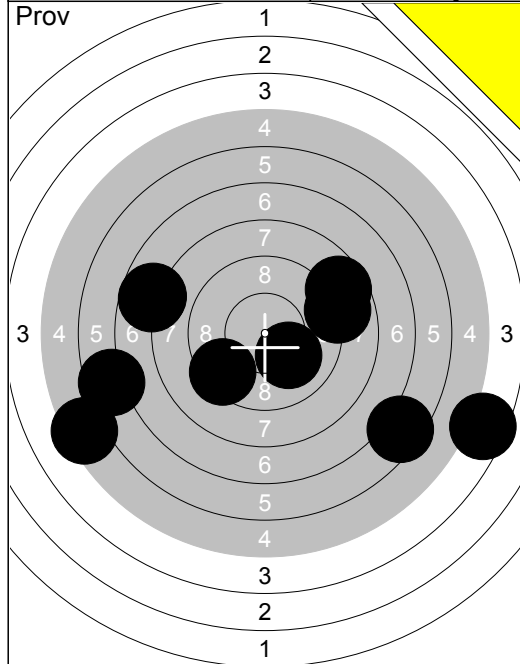

1: 6.6	←
2: 10.1	↘
3: 7.7	←
4: 9.4	↙
5: 4.5	↘
6: 8.9	→
7: 6.4	↘
8: 5.3	←
9: 7.7	←
10: 8.6	↗
<b>Serie 75.2</b>	
<b>Total 0.0</b>	

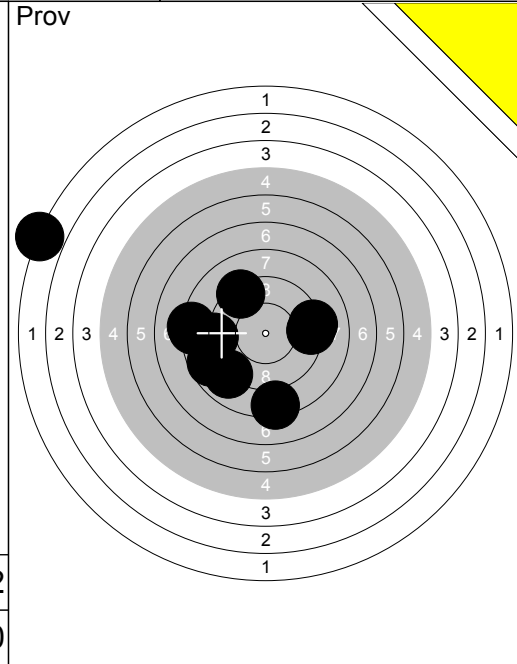

11: 8.2	←
12: 9.1	←
13: 9.2	→
14: 8.7	↙
15: 9.3	→
16: 8.9	↙
17: 8.3	↓
18: 8.3	←
19: 1.9	↖
20: 9.2	↗
<b>Serie 81.1</b>	
<b>Total 0.0</b>	

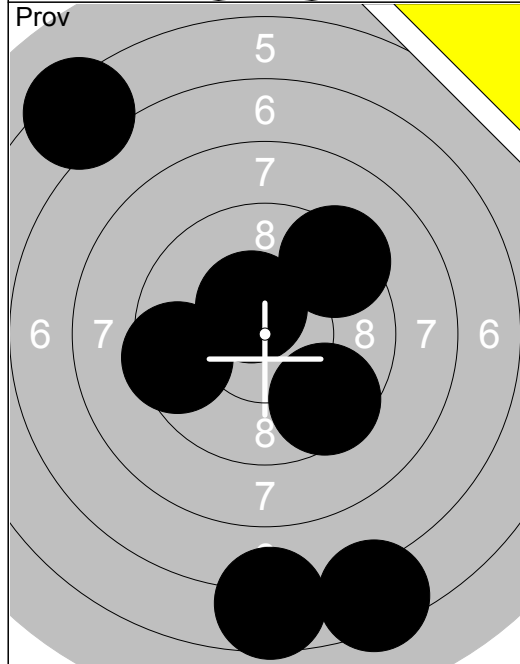

21: 9.3	↗
22: 9.5	↘
23: 6.6	↓
24: 9.5	←
25: 6.3	↗
26: 6.4	↘
27: *10.5	↘
<b>Serie 58.1</b>	
<b>Total 0.0</b>	

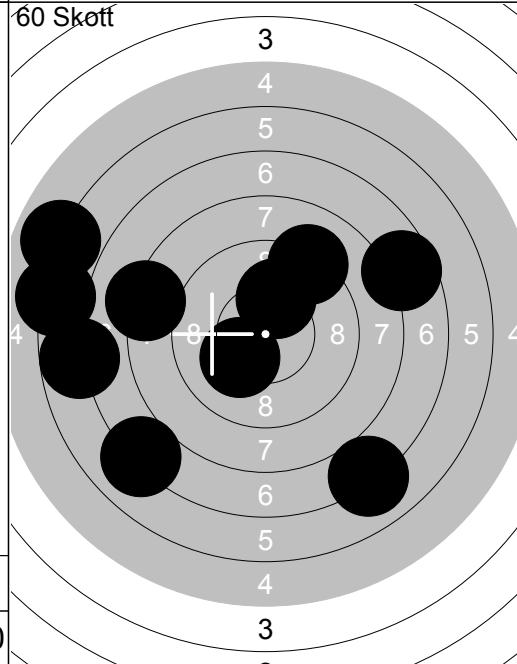

1: 5.9	←
2: 6.2	←
3: 7.0	↙
4: 10.1	↑
5: 9.1	↗
6: *10.2	↘
7: 7.0	↘
8: 6.8	←
9: 7.6	→
10: 8.2	←
<b>Serie 78.1</b>	
<b>Total 78.1</b>	

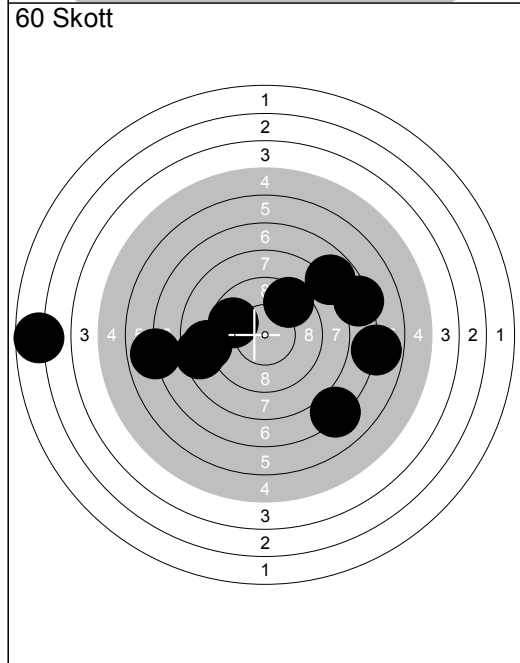

11: 9.7	←
12: 7.3	→
13: 9.5	↗
14: 6.8	→
15: 7.8	↗
16: 6.9	←
17: 2.7	←
18: 7.1	↘
19: 8.5	←
20: 8.8	←
<b>Serie 75.1</b>	
<b>Total 153.2</b>	

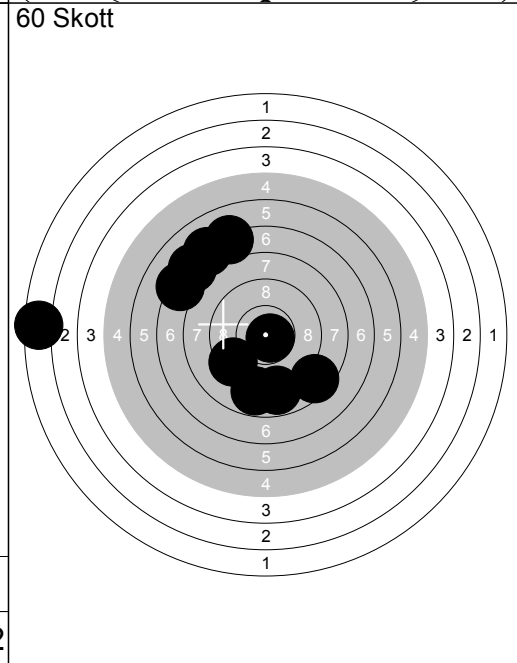

21: 7.1	↖
22: 7.2	↖
23: 8.8	↓
24: 2.4	←
25: 9.3	↙
26: 7.2	↗
27: 7.1	↗
28: 8.5	↘
29: *10.8	↘
30: 8.8	↓
<b>Serie 77.2</b>	
<b>Total 230.4</b>	

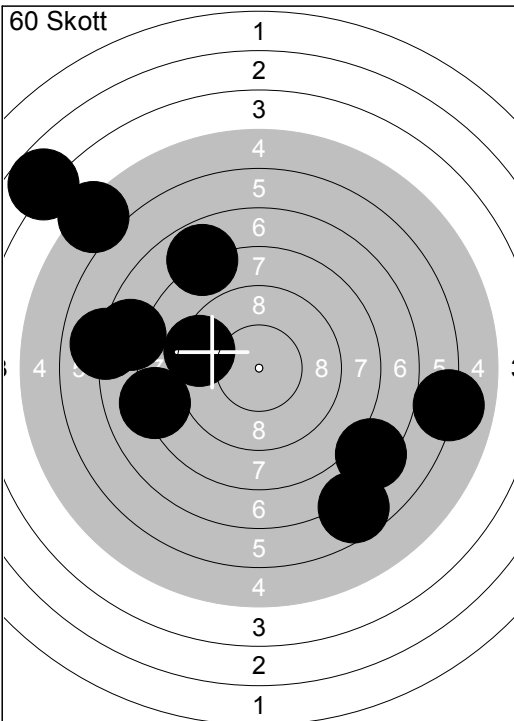

- 31: 7.0 ←
- 32: 7.6 ←
- 33: 7.3 ↘
- 34: 5.2 ↗
- 35: 7.8 ↗
- 36: 6.0 →
- 37: 8.1 ←
- 38: 9.4 ←
- 39: 3.7 ↗
- 40: 6.7 ↘

Serie	68.8
Total	299.2

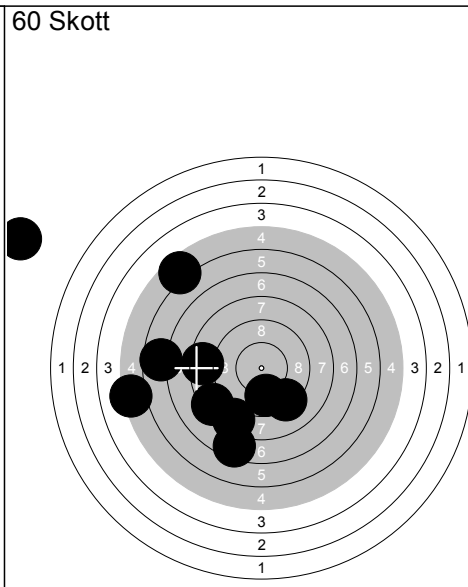

- 41: 8.4 ←
- 42: 8.4 ↘
- 43: 9.2 ↘
- 44: 0.0 ←
- 45: 6.6 ←
- 46: 8.3 ←
- 47: 5.2 ←
- 48: 7.4 ↘
- 49: 5.5 ↗
- 50: 9.8 ↘

Serie	68.8
Total	368.0

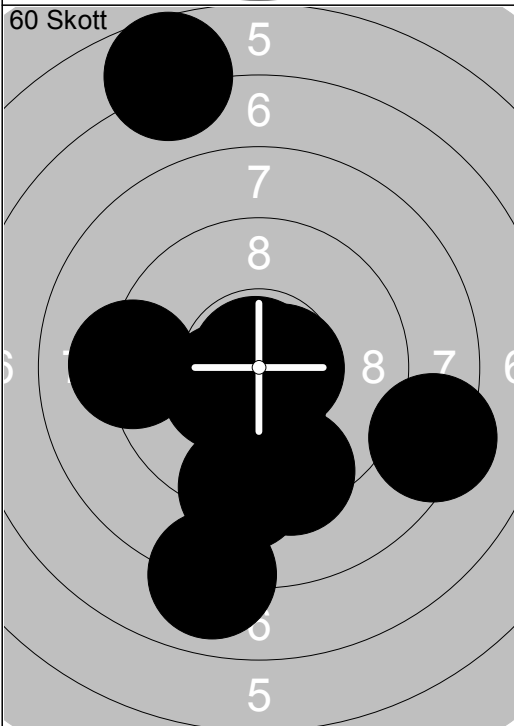

- 51: 9.2 ←
- 52: \*10.4 ↓
- 53: 6.7 ↗
- 54: \*10.7 →
- 55: 9.3 ↓
- 56: 8.0 ↓
- 57: 8.3 →
- 58: 9.4 ↘
- 59: \*10.8 ↘
- 60: \*10.4 ↘

Serie	93.2
Total	461.2

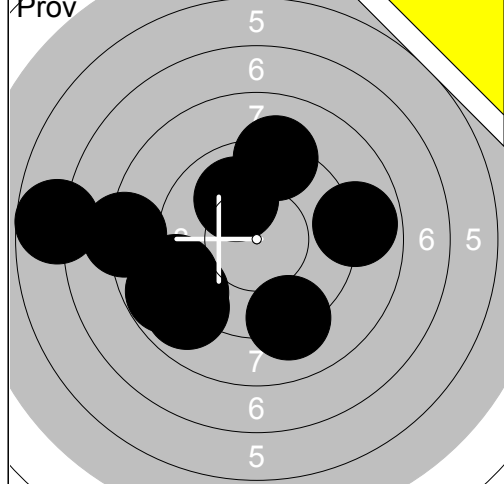

1:	9.2	↑
2:	9.1	←
3:	8.9	↘
4:	9.1	↘
5:	8.1	←
6:	6.7	←
7:	9.2	↘
8:	8.8	→
9:	10.0	↗
10:	8.8	←
Serie		87.9
Total		0.0

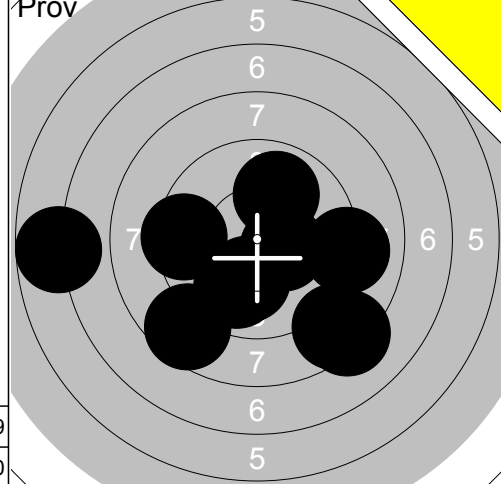

11:	9.9	↘
12:	*10.4	→
13:	8.5	↘
14:	10.1	↘
15:	8.6	↘
16:	6.8	←
17:	9.4	←
18:	9.9	↗
19:	9.1	→
20:	8.2	↘
Serie		90.9
Total		0.0

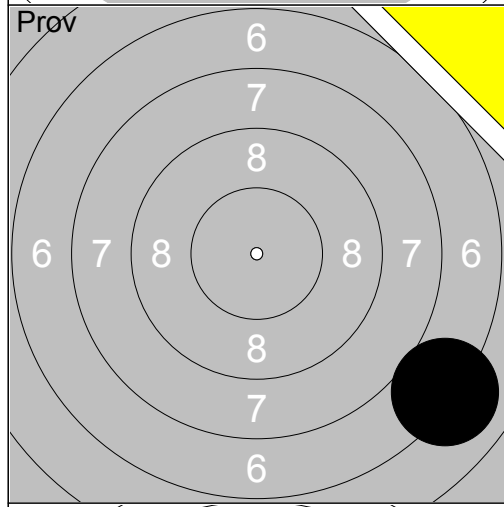

21:	7.0	↘
Serie		7.0
Total		0.0

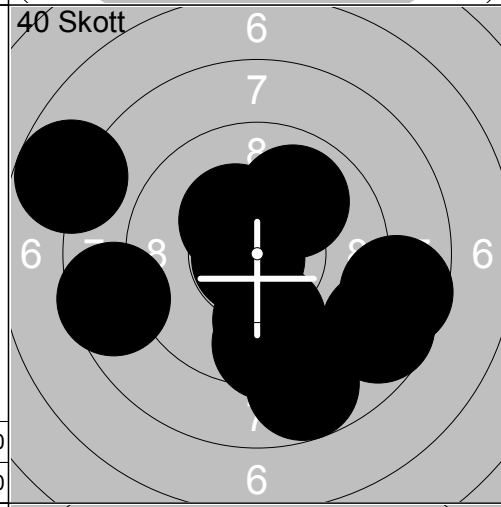

1:	9.9	↘
2:	*10.8	←
3:	9.5	↘
4:	8.8	↘
5:	7.7	↖
6:	*10.3	↗
7:	8.6	←
8:	8.7	→
9:	9.9	↗
10:	8.7	↘
Serie		92.9
Total		92.9

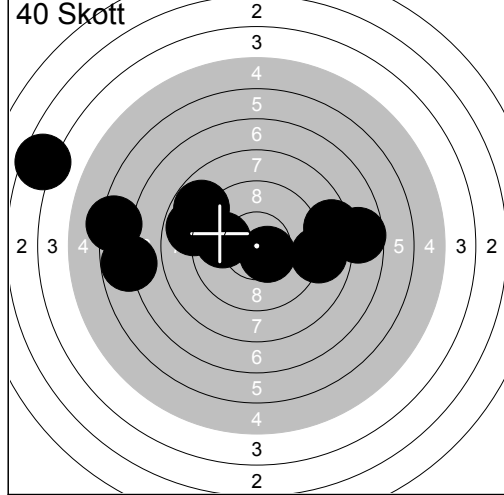

11:	8.5	→
12:	8.8	←
13:	6.3	←
14:	8.9	→
15:	7.7	→
16:	8.8	↗
17:	9.8	←
18:	6.8	←
19:	3.5	↖
20:	*10.5	↘
Serie		79.6
Total		172.5

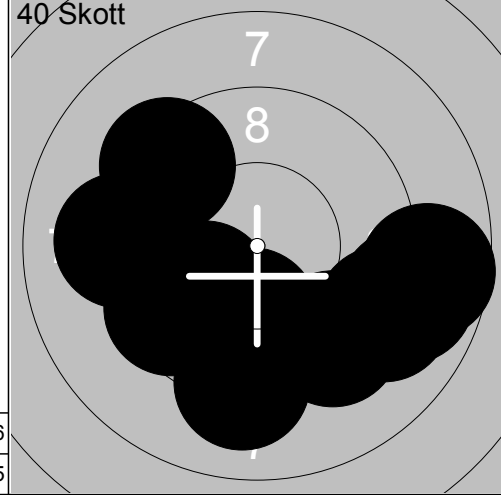

21:	10.0	↘
22:	9.1	→
23:	9.2	←
24:	9.4	↘
25:	9.1	↘
26:	8.7	→
27:	8.9	→
28:	9.6	↖
29:	10.0	↖
30:	9.4	↗
Serie		93.4
Total		265.9

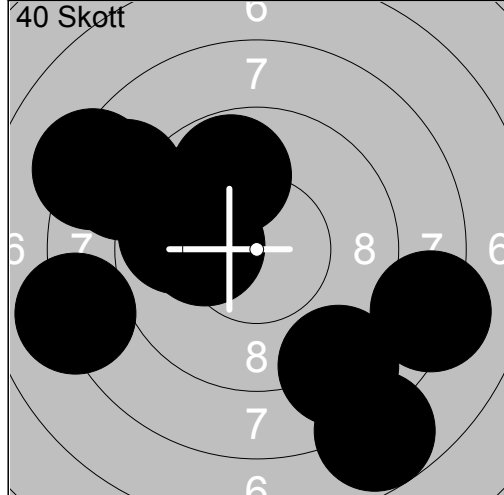

31:	8.8	↘
32:	8.2	→
33:	9.9	↗
34:	9.8	↗
35:	8.1	←
36:	*10.2	←
37:	7.7	↘
38:	9.8	←
39:	8.7	↗
40:	8.2	↗
Serie		89.4
Total		355.3

Prov 	1: 8.7 ↓ 2: 10.0 ↑ 3: 8.0 ↓ 4: 9.1 ↓ 5: 9.6 ↑ 6: *10.3 ↗ 7: 9.8 ↑ 8: 7.7 ← 9: 7.1 ← 10: *10.6 → Serie 90.9 Total 0.0	Prov 	11: 9.9 ↓ 12: 8.9 ↖ 13: 9.0 ↖ 14: 8.5 ↖ 15: *10.6 ↗ 16: 9.3 ↓ 17: *10.6 ↗ 18: 7.2 → 19: *10.4 ↓ 20: 9.2 ↑ Serie 93.6 Total 0.0
----------	---	----------	---

40 Skott 	1: 9.5 ↖ 2: 7.4 ← 3: *10.4 ↖ 4: *10.5 ↗ 5: 10.1 ↓ 6: 9.9 ↑ 7: 9.0 ↑ 8: *10.5 → 9: *10.8 ↓ 10: 9.1 ← Serie 97.2 Total 97.2	40 Skott 	11: 9.7 ↖ 12: *10.4 ↗ 13: 9.9 ↓ 14: 9.8 ↖ 15: 9.7 ↓ 16: *10.3 ↓ 17: 9.7 ↑ 18: 9.4 ← 19: *10.4 ↓ 20: 8.9 ← Serie 98.2 Total 195.4
--------------	--	--------------	---

40 Skott 	21: 7.9 ← 22: *10.5 ↑ 23: 9.6 ↓ 24: 9.7 ← 25: *10.4 ↖ 26: 9.3 ↑ 27: 8.0 ← 28: 8.7 → 29: 9.8 ↑ 30: 8.6 ← Serie 92.5 Total 287.9	40 Skott 	31: 9.2 ↑ 32: 7.5 → 33: 8.7 ↓ 34: 9.0 ↓ 35: 8.1 ← 36: 9.0 ↑ 37: 7.6 ← 38: 9.1 ↖ 39: 8.4 ↗ 40: *10.4 ↖ Serie 87.0 Total 374.9
--------------	---	--------------	---

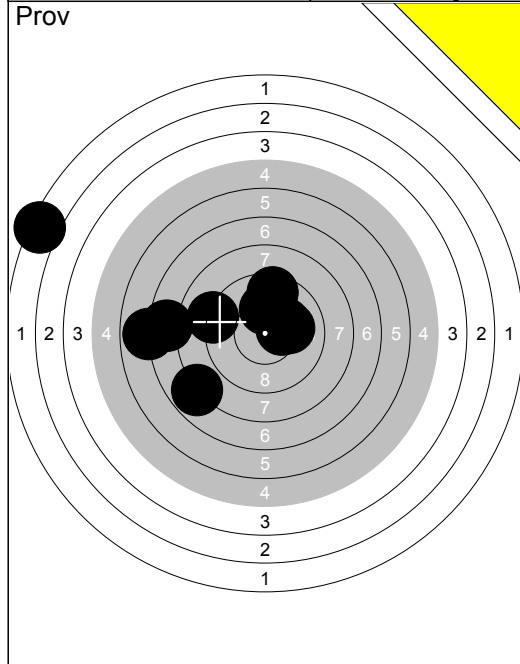

1:	*10.3 →
2:	7.5 ←
3:	6.8 ←
4:	7.8 ↙
5:	9.0 ←
6:	10.1 ↑
7:	*10.2 →
8:	10.1 →
9:	9.5 ↑
10:	2.2 ↙
<b>Serie 83.5</b>	
<b>Total 0.0</b>	

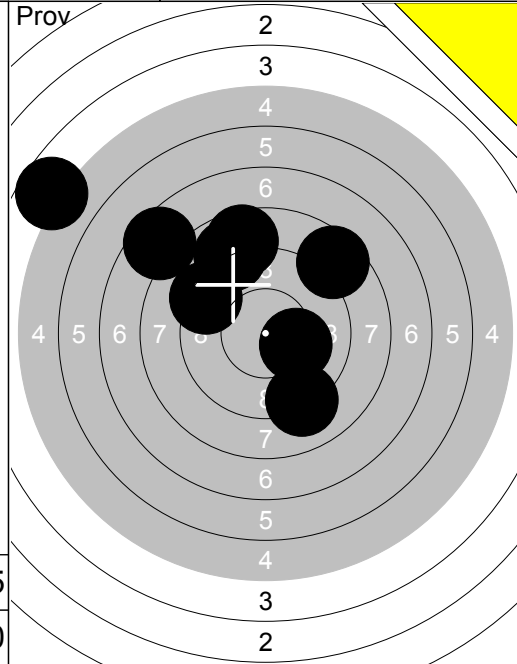

11:	8.6 ↑
12:	8.8 ↑
13:	*10.2 →
14:	9.2 ↙
15:	7.5 ↙
16:	8.5 ↗
17:	4.6 ↙
18:	9.1 ↓
<b>Serie 66.5</b>	
<b>Total 0.0</b>	

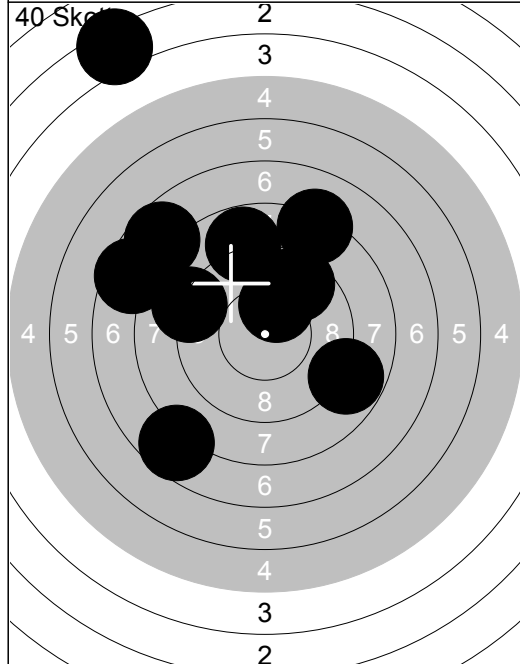

1:	3.3 ↖
2:	*10.2 ↑
3:	8.1 ↑
4:	9.0 ↙
5:	8.8 ↑
6:	9.5 ↗
7:	7.5 ↙
8:	7.7 ↖
9:	8.8 →
10:	7.6 ↙
<b>Serie 80.5</b>	
<b>Total 80.5</b>	

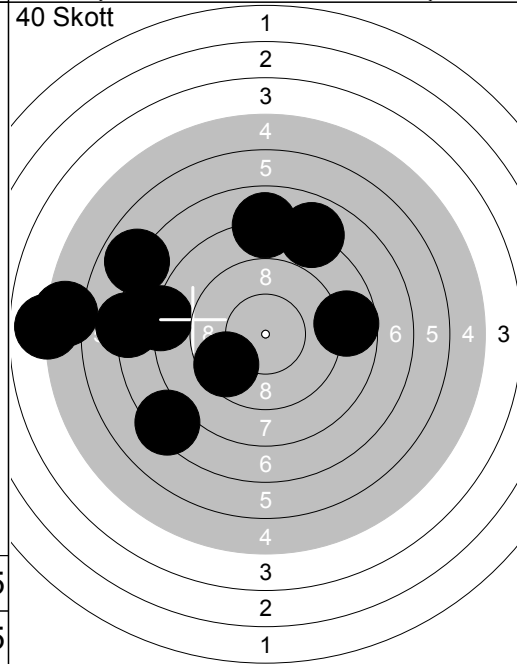

11:	4.9 ←
12:	6.9 ↙
13:	9.6 ↙
14:	7.1 ←
15:	7.9 ↑
16:	8.7 →
17:	5.4 ←
18:	8.0 ←
19:	7.9 ↑
20:	7.3 ↙
<b>Serie 73.7</b>	
<b>Total 154.2</b>	

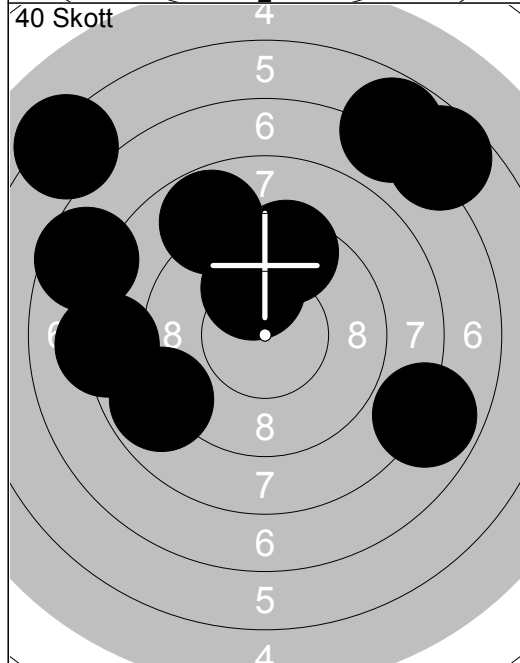

21:	8.8 ↙
22:	8.2 ←
23:	10.1 ↑
24:	9.5 ↑
25:	7.6 ↙
26:	6.8 ↗
27:	8.8 ↑
28:	6.2 ↖
29:	6.6 ↗
30:	7.9 →
<b>Serie 80.5</b>	
<b>Total 234.7</b>	

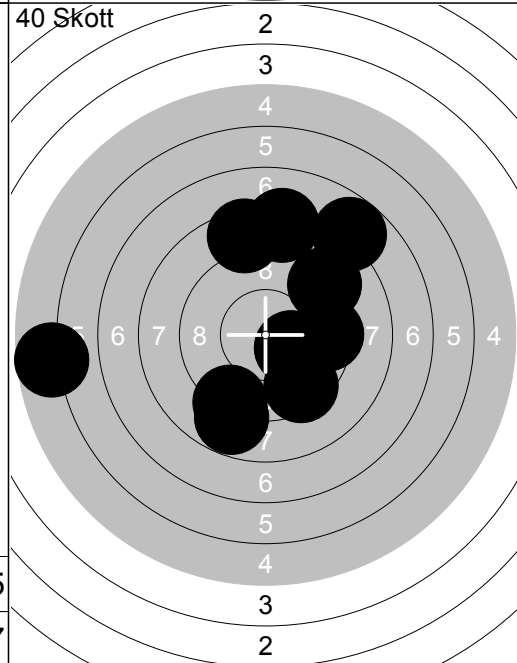

31:	*10.2 →
32:	9.1 ↓
33:	8.2 ↑
34:	7.8 ↗
35:	5.7 ←
36:	9.0 ↗
37:	9.4 ↓
38:	9.5 →
39:	8.5 ↑
40:	8.8 ↓
<b>Serie 86.2</b>	
<b>Total 320.9</b>	



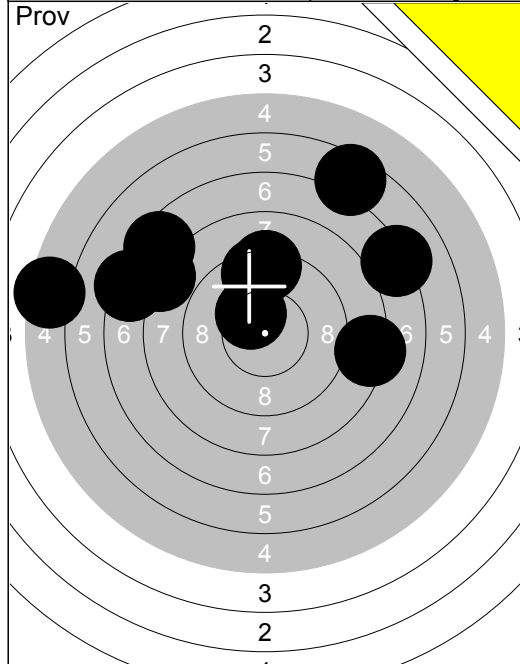

11:	9.6	↗
12:	9.2	↗
13:	9.3	↗
14:	9.9	↖
15:	9.4	↖
16:	7.0	↖
17:	*10.2	↘
Serie		64.6
Total		0.0

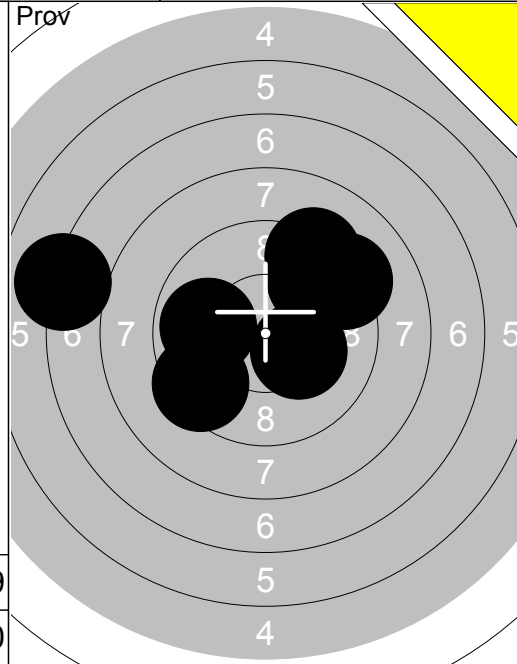

11:	9.6	↗
12:	9.2	↗
13:	9.3	↗
14:	9.9	↖
15:	9.4	↖
16:	7.0	↖
17:	*10.2	↘
Serie		64.6
Total		0.0

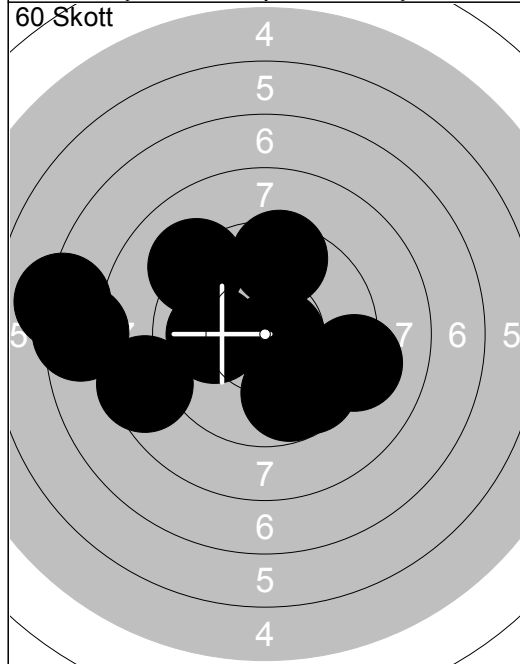

11:	*10.5	↗
12:	*10.5	↘
13:	8.4	↖
14:	9.6	↖
15:	10.0	↗
16:	9.0	↖
17:	*10.7	↘
18:	9.2	↖
19:	7.2	↖
20:	8.3	→
Serie		93.4
Total		184.6

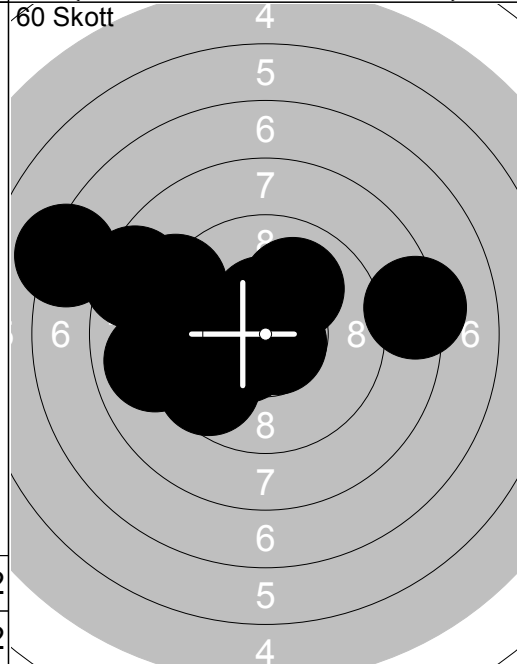

11:	*10.5	↗
12:	*10.5	↘
13:	8.4	↖
14:	9.6	↖
15:	10.0	↗
16:	9.0	↖
17:	*10.7	↘
18:	9.2	↖
19:	7.2	↖
20:	8.3	→
Serie		93.4
Total		184.6

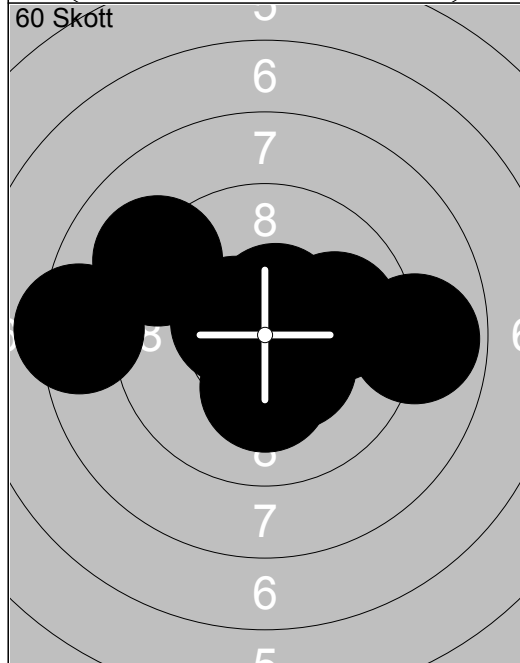

31:	9.2	↖
32:	9.5	→
33:	10.0	↗
34:	9.5	→
35:	*10.5	↘
36:	9.7	↖
37:	8.8	↖
38:	9.5	↓
39:	10.0	↓
40:	8.7	→
Serie		95.4
Total		379.2

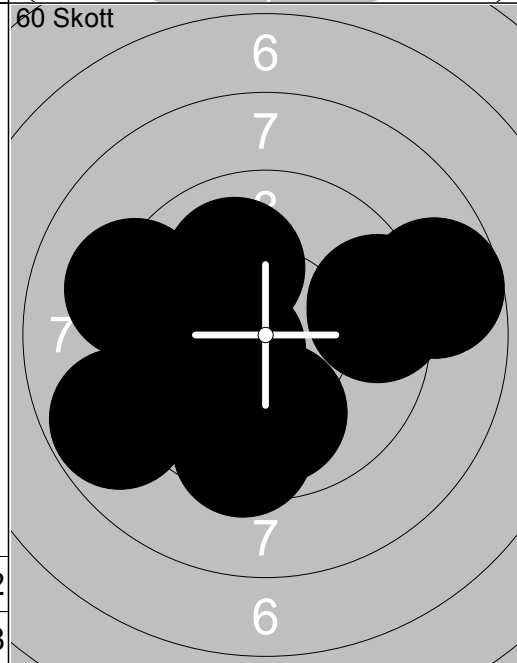

31:	9.2	↖
32:	9.5	→
33:	10.0	↗
34:	9.5	→
35:	*10.5	↘
36:	9.7	↖
37:	8.8	↖
38:	9.5	↓
39:	10.0	↓
40:	8.7	→
Serie		95.4
Total		379.2



<p>Prov</p>	<p>1: 8.4 ↖ 2: *10.4↑ 3: 9.8 ↗ 4: 10.0↑ 5: 9.9 ↖ 6: *10.8↑ 7: *10.2→ 8: 9.6 ↗ 9: *10.3↓ 10: 10.1↑</p> <p>Serie 99.5 Total 0.0</p>	<p>Prov</p>	<p>11: *10.5↖</p> <p>Serie 10.5 Total 0.0</p>
-------------	---	-------------	---

<p>40 Skott</p>	<p>1: 9.7↑ 2: 9.2↖ 3: *10.3→ 4: 9.4↗ 5: 9.5↗ 6: 10.0→ 7: *10.2↑ 8: *10.3→ 9: 9.8↖ 10: *10.5→</p> <p>Serie 98.9 Total 98.9</p>	<p>40 Skott</p>	<p>11: 8.9↖ 12: 9.9↓ 13: *10.4↑ 14: *10.2→ 15: 10.1→ 16: *10.7→ 17: 10.0↓ 18: 9.3→ 19: *10.8↖ 20: 8.8↘</p> <p>Serie 99.1 Total 198.0</p>
-----------------	---	-----------------	--

<p>40 Skott</p>	<p>21: 8.9→ 22: *10.5↓ 23: 9.5↖ 24: 9.9↘ 25: 9.3↗ 26: *10.3↓ 27: 8.0→ 28: *10.2→ 29: 9.9↘ 30: *10.4↓</p> <p>Serie 96.9 Total 294.9</p>	<p>40 Skott</p>	<p>31: 9.8↗ 32: 9.4↘ 33: 9.7↗ 34: 10.0→ 35: *10.5→ 36: 10.0↓ 37: 9.9→ 38: 9.8↖ 39: 9.4→ 40: 10.0↗</p> <p>Serie 98.5 Total 393.4</p>
-----------------	--	-----------------	---

Prov 	1: 9.9 ↘ 2: 9.7 → 3: 9.8 ↑ 4: *10.3→ 5: *10.3↘ 6: 9.5 ↖ 7: *10.3↘ 8: *10.3↗ 9: 9.7 ↗ 10: 9.5 ↘ <hr/> Serie 99.3 Total 0.0	Prov 	11: 9.7 → 12: 7.1 ↖ 13: 8.3 ↗ 14: *10.4↖ 15: 9.3 ↖ 16: 9.7 ↗ 17: 9.7 ↗ 18: 9.8 → 19: *10.6↘ <hr/> Serie 84.6 Total 0.0
----------	--	----------	--

60 Skott 	1: 10.1→ 2: 9.8 ↖ 3: 9.3 ↘ 4: 10.1↗ 5: *10.2↑ 6: *10.2↘ 7: *10.9↖ 8: *10.3↖ 9: *10.2↖ 10: *10.5↗ <hr/> Serie 101.6 Total 101.6	60 Skott 	11: 9.7 ← 12: 9.6 → 13: 9.7 ↖ 14: 9.7 ↑ 15: *10.5↖ 16: 10.0↖ 17: 8.0 ↖ 18: 9.8 → 19: *10.3↑ 20: 9.8 ↖ <hr/> Serie 97.1 Total 198.7
--------------	---	--------------	---

60 Skott 	21: 10.1 ↘ 22: 9.9 ↘ 23: *10.4→ 24: 9.5 ↖ 25: *10.4↑ 26: *10.8↑ 27: 8.9 ↑ 28: 9.5 ↖ 29: 10.0↗ 30: 9.8 ↖ <hr/> Serie 99.3 Total 298.0	60 Skott 	31: *10.5↖ 32: 10.0 ↖ 33: *10.3↘ 34: *10.2↑ 35: *10.2↖ 36: *10.2↗ 37: *10.5↘ 38: 10.0 ↑ 39: 8.8 ↑ 40: *10.6↘ <hr/> Serie 101.3 Total 399.3
--------------	---	--------------	---

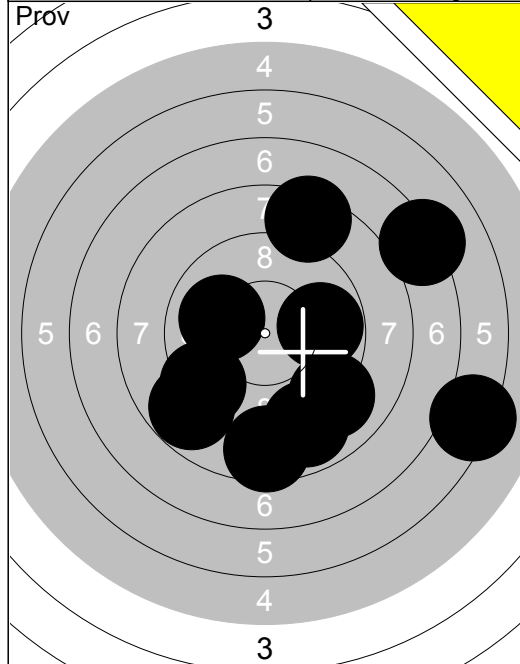

1:	9.3	↙
2:	8.9	↓
3:	8.8	↙
4:	9.8	→
5:	8.4	↑
6:	6.3	→
7:	9.0	↘
8:	8.5	↓
9:	7.1	↗
10:	10.0	←
Serie		82.0
Total		0.0

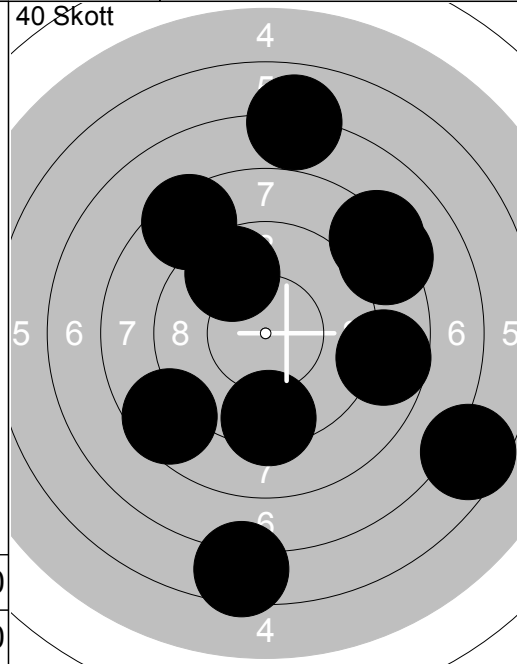

1:	8.4	↖
2:	8.3	↗
3:	8.7	→
4:	9.7	↖
5:	8.2	↗
6:	6.5	↓
7:	9.4	↓
8:	7.0	↑
9:	8.6	↙
10:	6.5	↘
Serie		77.0
Total		77.0

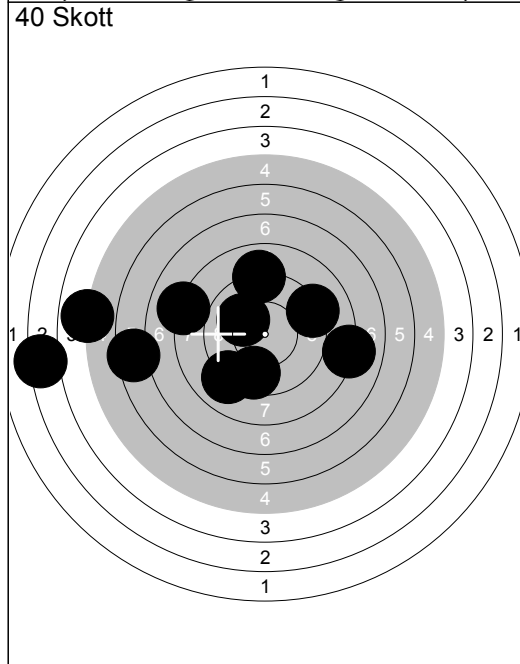

11:	9.6	↓
12:	4.9	←
13:	3.2	←
14:	9.0	↑
15:	6.4	←
16:	8.0	←
17:	9.2	↗
18:	8.0	→
19:	10.1	↖
20:	9.0	↘
Serie		75.0
Total		152.0

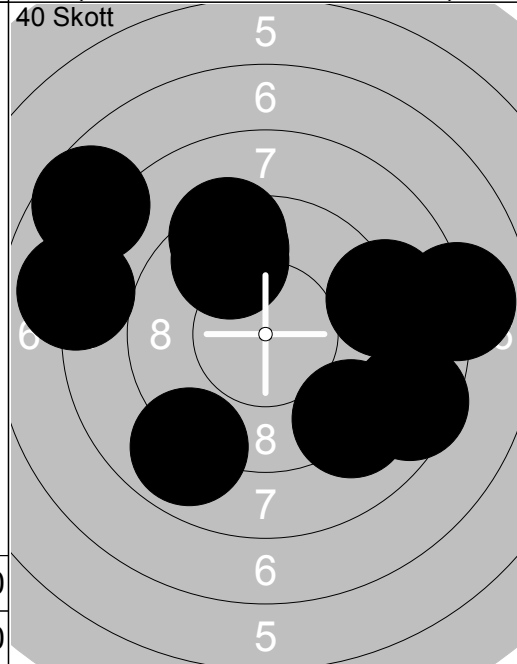

21:	8.0	←
22:	9.1	→
23:	9.1	↘
24:	9.7	↖
25:	9.4	↑
26:	8.9	↙
27:	7.6	↖
28:	9.5	↑
29:	8.0	→
30:	8.5	↘
Serie		84.0
Total		236.0

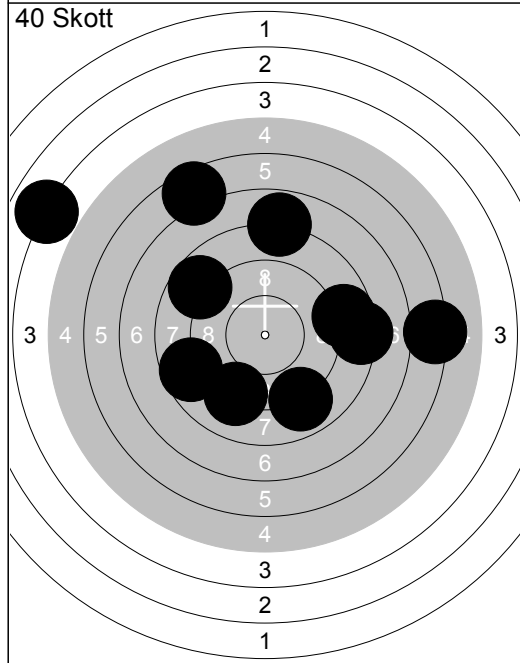

31:	8.7	→
32:	8.7	←
33:	3.9	↖
34:	8.7	↖
35:	7.8	↑
36:	9.1	↙
37:	6.2	→
38:	6.5	↖
39:	8.9	↓
40:	8.3	→
Serie		71.0
Total		307.0

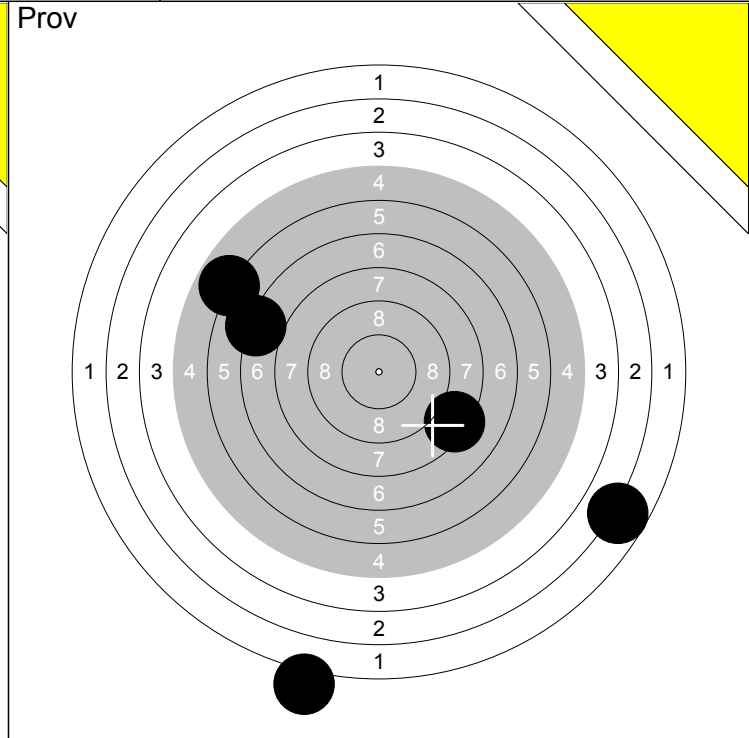
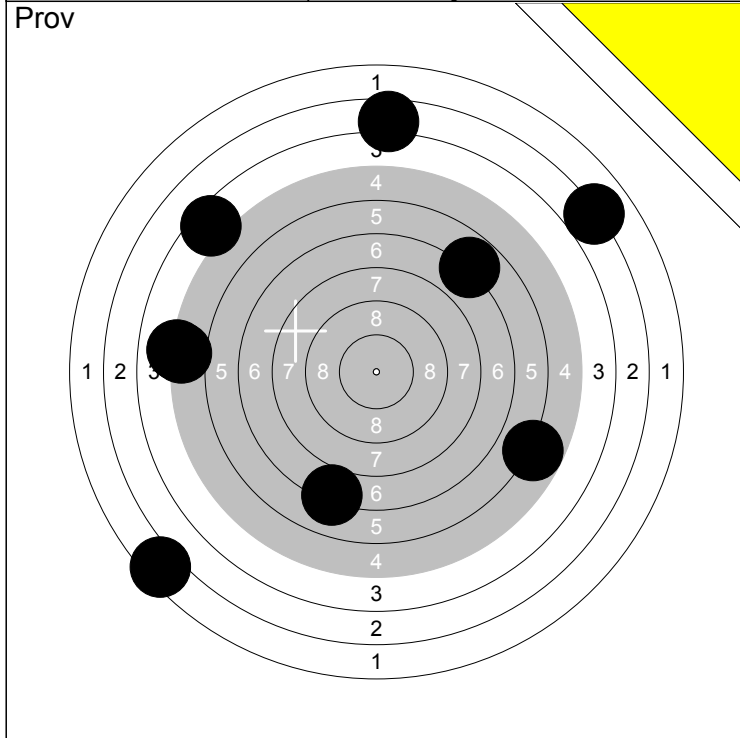

1: 0.0 ↖	6: 3.5 ↑	Serie	40.0
2: 4.4 ↗	7: 5.1 ←		
3: 5.0 ←	8: 3.0 ↗	Total	0.0
4: 6.8 ↗	9: 2.3 ↖		
5: 7.1 ↘	10: 5.7 ↘		

11: 1.4 ↘	16: 7.0 ↖	Serie	23.0
12: 0.0 →			
13: 2.7 ↘		Total	0.0
14: 8.3 ↘			
15: 5.8 ↖			

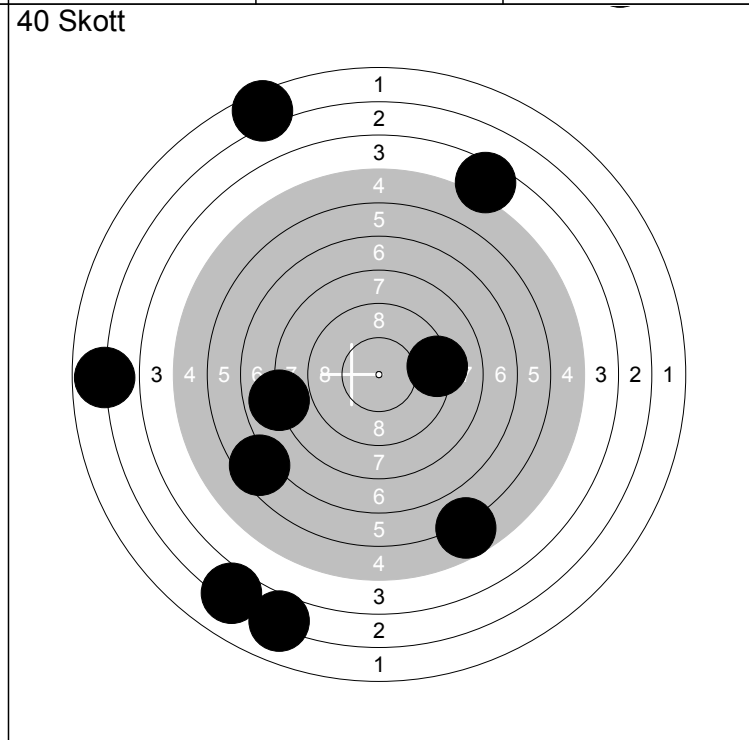
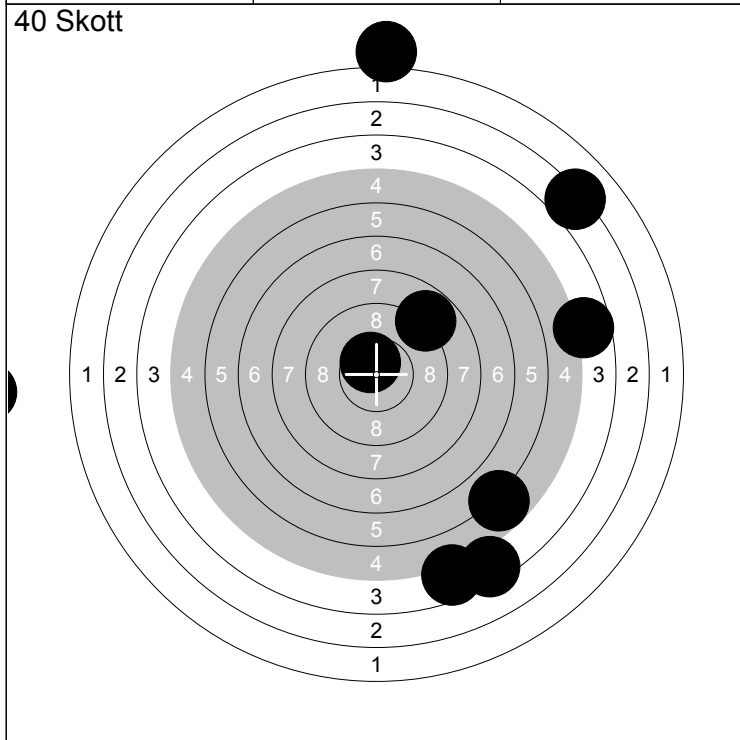

1: 3.1 ↗	6: 0.0 ←	Serie	39.0
2: 4.6 ↘	7: 4.6 →		
3: 8.8 ↗	8: *10.5 ↗	Total	39.0
4: 1.4 ↑	9: 4.3 ↘		
5: 0.0 ←	10: 5.7 ↘		

11: 4.4 ↗	16: 9.2 →	Serie	41.0
12: 6.5 ↖	17: 2.8 ←		
13: 7.9 ←	18: 3.1 ↘	Total	80.0
14: 0.0 ↗	19: 3.1 ↘		
15: 2.4 ↖	20: 5.7 ↘		

Prov 	1: 9.8 → 2: 7.0 ← 3: 9.2 ↘ 4: 4.5 → 5: 9.5 ← 6: 10.0 ↙	40 Skott 	1: 9.0 ↑ 2: 9.3 ↗ 3: 9.7 ↘ 4: 6.1 ↗ 5: 6.7 ← 6: 2.7 ↑ 7: 7.7 ↗ 8: 6.8 ← 9: 3.2 → 10: 4.7 ↗
Serie 50.0		Serie 65.9	
Total 0.0		Total 65.9	

40 Skott 	11: 8.9 ↗ 12: 7.6 → 13: 7.7 ↓ 14: 8.3 ← 15: 7.9 ↘ 16: 7.3 ↗ 17: 6.3 ← 18: 9.0 ↘ 19: 9.9 ↑ 20: 7.9 ↑	40 Skott 	21: 8.0 ↗ 22: 6.5 ↓ 23: 9.6 ↑ 24: 8.1 ↘ 25: 6.7 ↑ 26: *10.2 ↘ 27: 9.9 ← 28: 6.8 ↑ 29: 5.9 ← 30: *10.5 ↘
Serie 80.8		Serie 82.2	
Total 146.7		Total 228.9	

40 Skott 	31: *10.8 → 32: *10.4 → 33: 8.1 ↑ 34: 7.9 ↑ 35: 7.6 → 36: 8.8 ↗ 37: 9.3 ↓ 38: 5.7 ↗ 39: 9.5 ← 40: 8.7 ↗		
Serie 86.8			
Total 315.7			