



Skjutlag <b>4</b>	Tavla <b>21</b>	<b>Hugo Nyberg</b>		
----------------------	--------------------	--------------------	--	--

10m	Drängsmark	Sitt	Vb
-----	------------	------	----

02.11.2014	Vindelnskyttet 2014	Ramselefors SKF
------------	---------------------	-----------------

<b>Prov</b> 	1:	*10.5	→
	2:	*10.4	↙
	3:	10.1	↓
	4:	*10.2	↙
	5:	*10.6	↗
	6:	*10.4	↓
	7:	10.0	↓
	8:	10.0	↓
	9:	*10.5	↓
	10:	*10.3	↓
	<b>Serie</b>		<b>103.0</b>
<b>Total</b>		<b>0.0</b>	

<b>Prov</b> 	11:	*10.6	↓
	12:	*10.4	→
	13:	*10.4	↙
	14:	*10.7	↙
	15:	*10.2	↙
	16:	9.9	↓
	17:	*10.3	↘
	18:	*10.4	↓
	<b>Serie</b>		<b>82.9</b>
<b>Total</b>		<b>0.0</b>	

<b>40 Skott</b> 	1:	*10.8	↘
	2:	9.8	↘
	3:	*10.4	↑
	4:	*10.2	↘
	5:	9.7	↘
	6:	10.1	↗
	7:	10.0	↓
	8:	*10.3	↘
	9:	9.9	↙
	10:	9.7	↓
	<b>Serie</b>		<b>100.9</b>
<b>Total</b>		<b>100.9</b>	

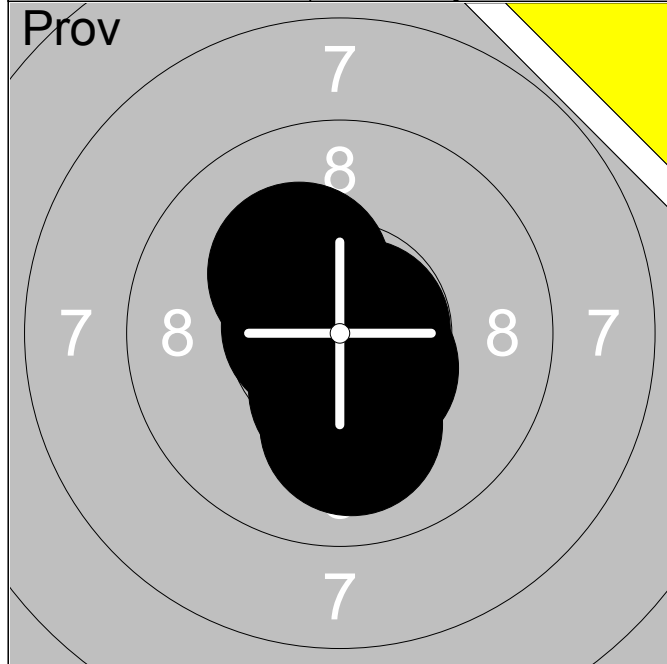

1:	*10.8	→
2:	*10.2	↗
3:	*10.8	←
4:	*10.6	↓
5:	*10.7	↖
6:	*10.2	↓
7:	*10.8	↗
8:	10.0	↓
9:	*10.4	↓
10:	*10.5	↓

Serie	105.0
-------	-------

Total	0.0
-------	-----

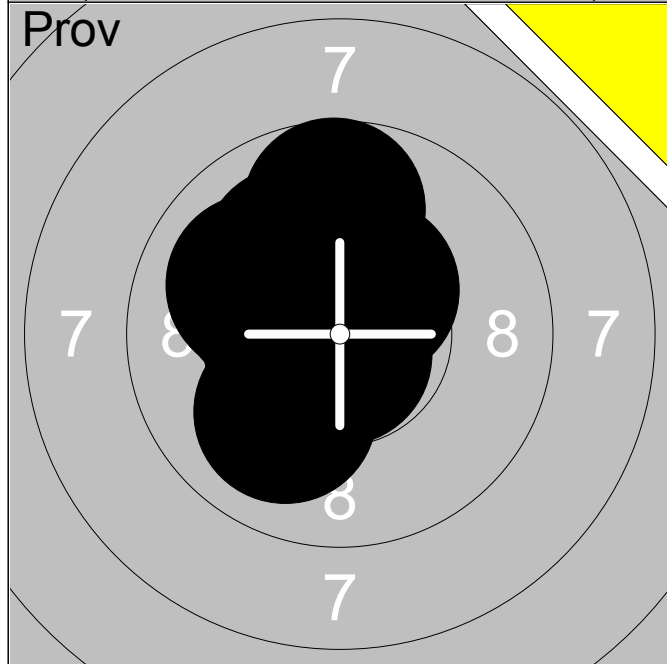

11:	*10.8	↓
12:	*10.2	↗
13:	*10.4	↗
14:	*10.3	↗
15:	10.1	↗
16:	*10.5	←
17:	10.0	↙
18:	9.7	↑
19:	10.0	↗

Serie	92.0
-------	------

Total	0.0
-------	-----

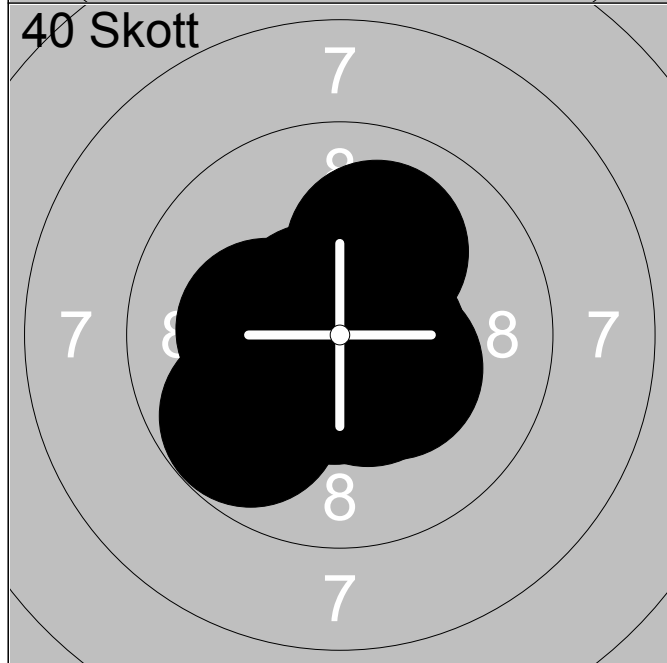

1:	*10.3	↘
2:	*10.6	↗
3:	10.1	↗
4:	*10.6	→
5:	*10.6	↓
6:	*10.7	↓
7:	*10.2	←
8:	*10.5	↓
9:	9.8	↙
10:	*10.9	↓

Serie	104.3
-------	-------

Total	104.3
-------	-------

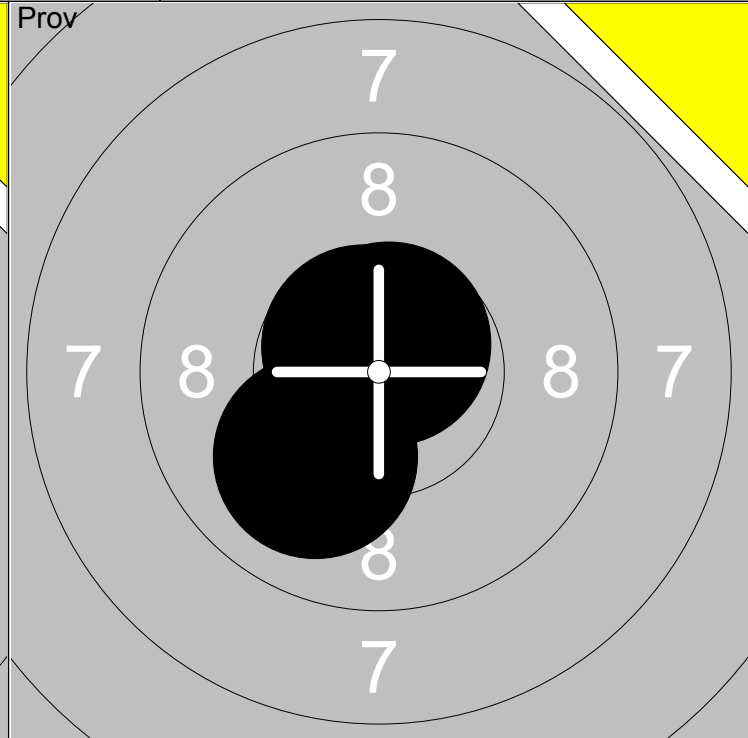
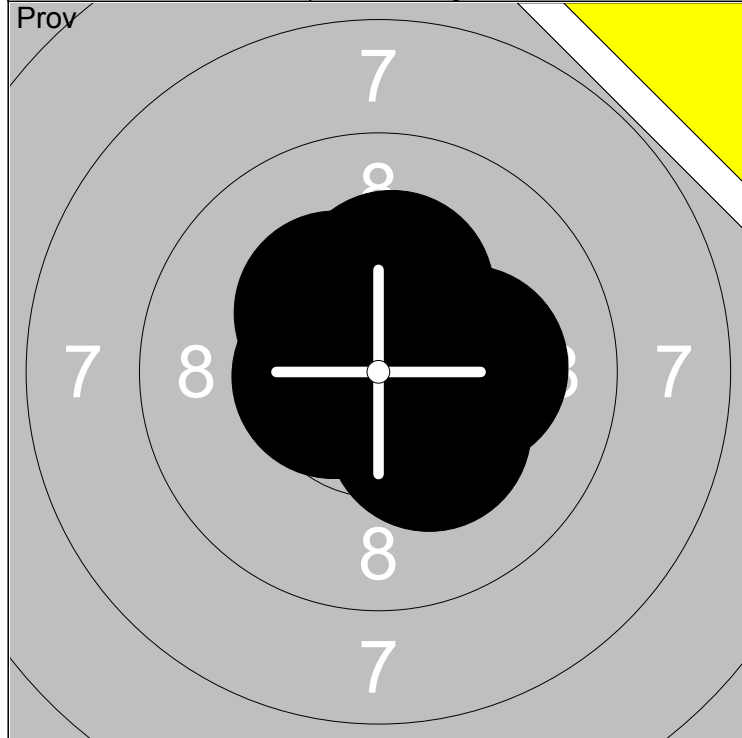

1: *10.3 ↘	6: *10.2 →	Serie	105.4
2: *10.6 →	7: *10.7 ↙		
3: *10.3 ↖	8: *10.9 ↙	Total	0.0
4: *10.9 ↑	9: *10.2 ↑		
5: *10.7 ↗	10: *10.6 ↙		

11: 10.0 ↙	Serie	31.4
12: *10.7 ↖		
13: *10.7 ↗	Total	0.0

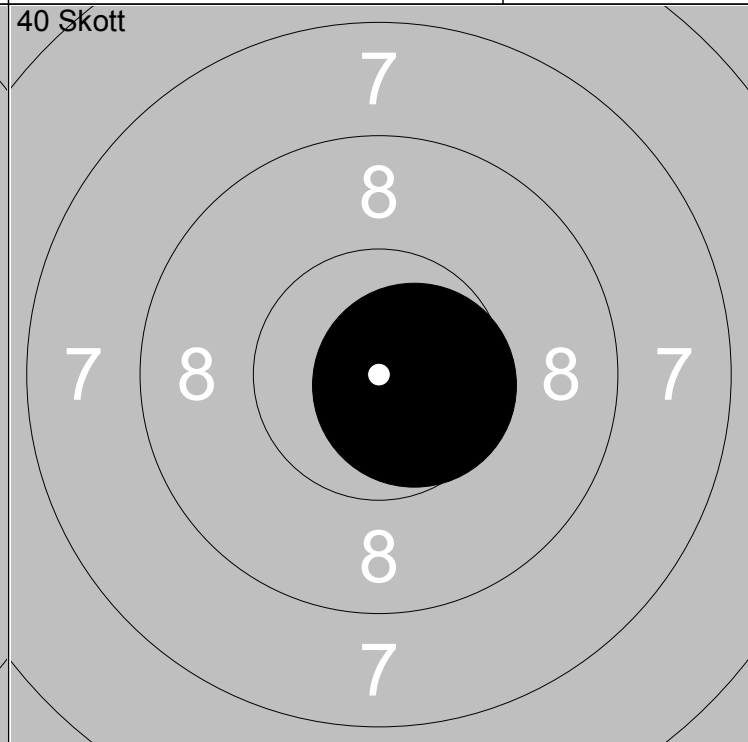
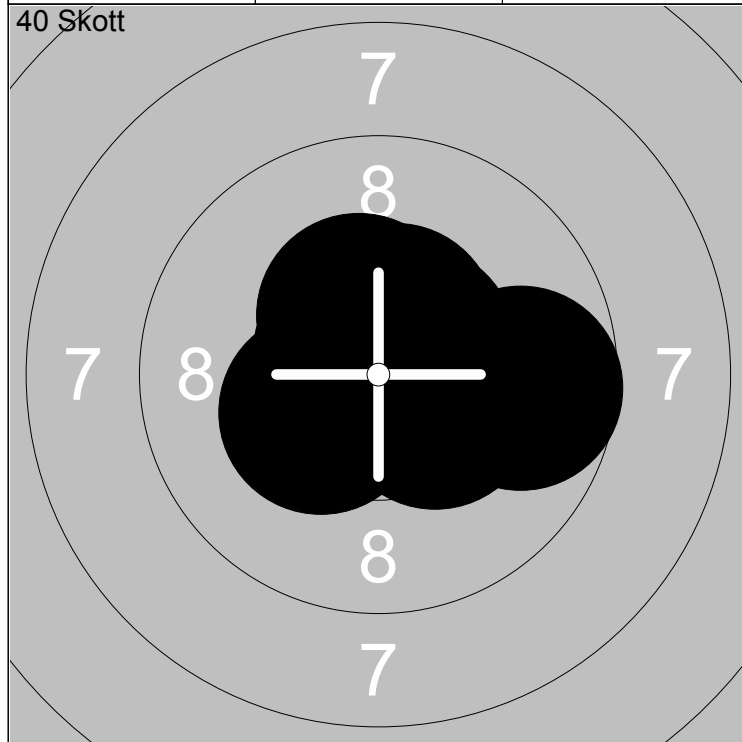

1: *10.3 ↘	6: 9.7 →	Serie	104.4
2: *10.7 ↙	7: *10.7 ↖		
3: *10.4 ↑	8: *10.4 →	Total	104.4
4: *10.6 →	9: *10.5 ↑		
5: *10.5 →	10: *10.6 ↗		

11: *10.6 →	Serie	10.6
	Total	115.0

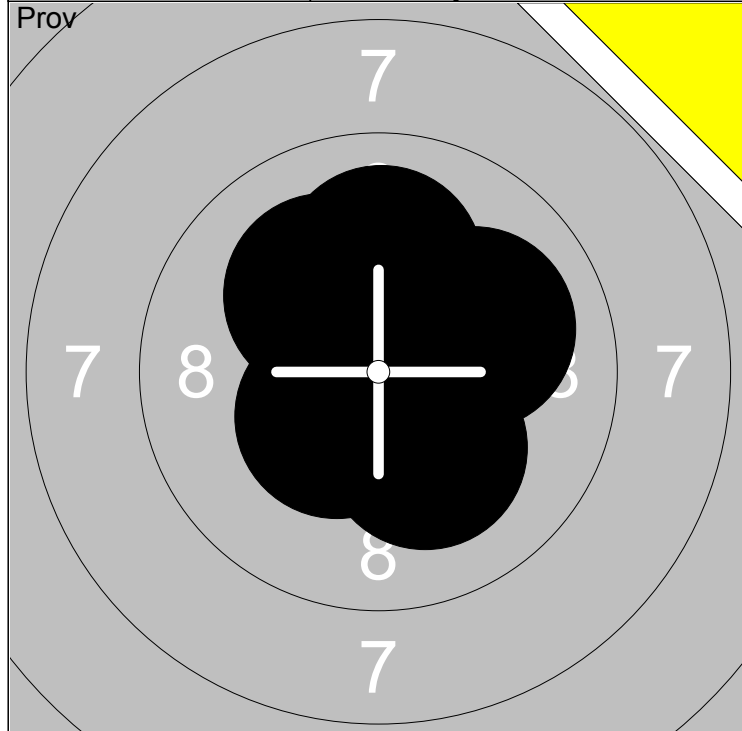

1: *10.9 ↗	6: *10.7 →	Serie	103.8
2: 10.1 ↘	7: *10.6 ↗		
3: *10.4 ↗	8: *10.2 ↘	Total	0.0
4: 10.0 ↑	9: *10.5 ↑		
5: *10.4 ↙	10: 10.0 →		

11: *10.5 ↗	Serie	31.7
12: *10.5 ↘		
13: *10.7 →	Total	0.0

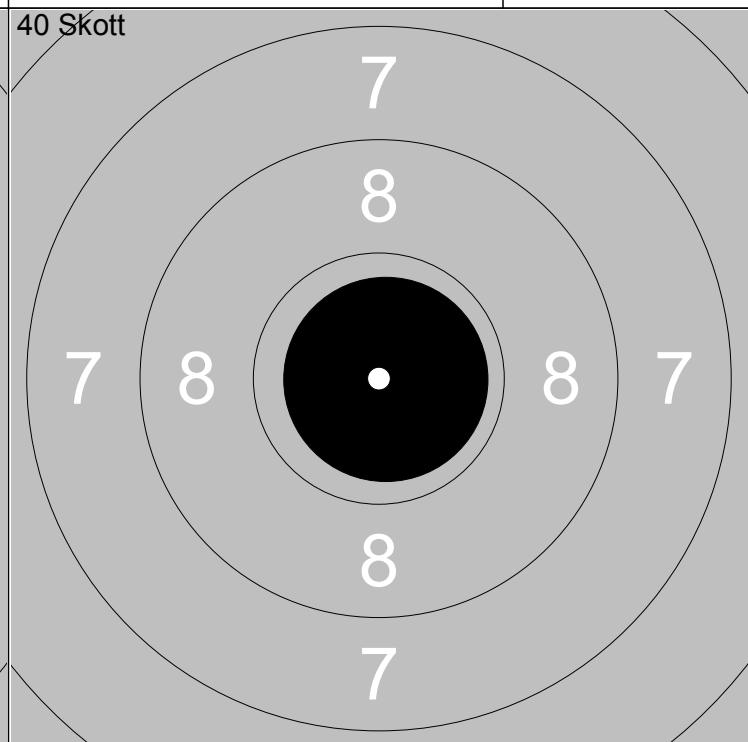
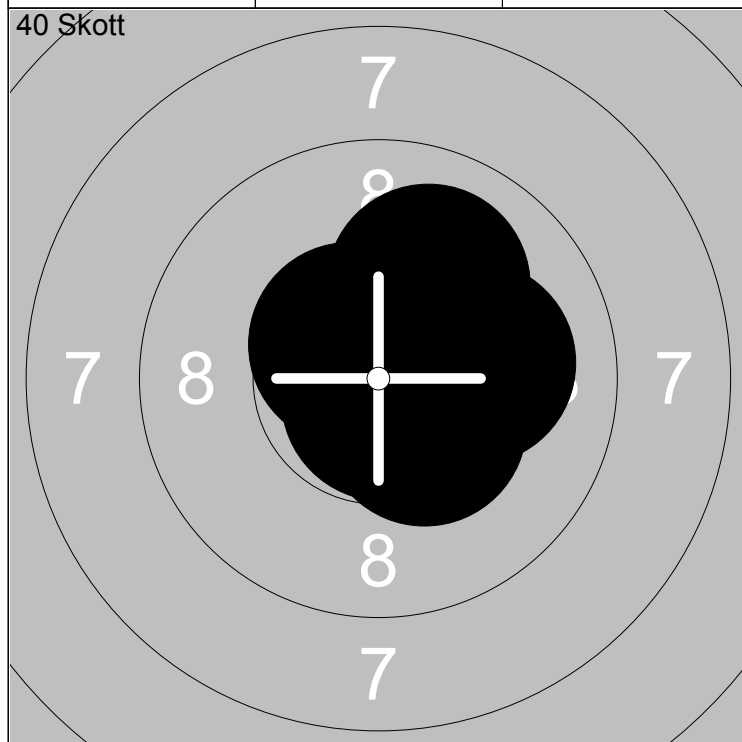

1: 10.1 →	6: *10.8 ↘	Serie	104.4
2: *10.8 →	7: *10.6 ↘		
3: *10.5 ↑	8: *10.5 ↑	Total	104.4
4: *10.3 ↗	9: 10.0 ↗		
5: *10.4 ↘	10: *10.4 ↗		

11: *10.9 →	Serie	10.9
	Total	115.3

Skjutlag <b>4</b>	Tavla <b>25</b>	<b>Leo Asplund</b>
----------------------	--------------------	--------------------

10m	I 19	Sitt	No
-----	------	------	----

02.11.2014	Vindelnskyttet 2014	Ramselefors SKF
------------	---------------------	-----------------

<b>Prov</b> 	1:	*10.6	→
	2:	*10.3	→
	3:	10.0	↓
	4:	*10.4	↓
	5:	*10.2	↓
	6:	*10.4	←
	7:	*10.4	↙
	8:	*10.4	↗
	9:	9.8	↙
	10:	*10.7	←
	Serie		103.2
Total		0.0	

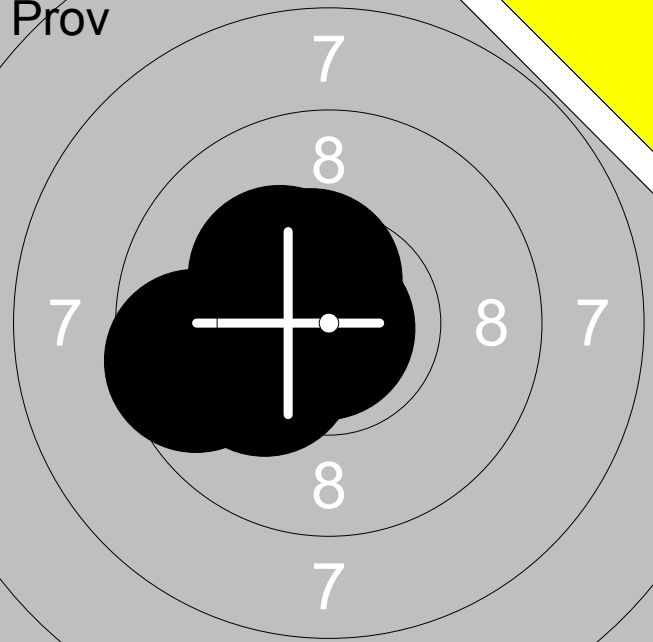
<b>Prov</b> 	11:	*10.9	↙
	12:	9.6	←
	13:	*10.8	↙
	14:	*10.6	←
	15:	*10.4	←
	16:	*10.2	↙
	17:	*10.5	←
	18:	*10.4	←
	19:	*10.5	↑
	20:	*10.3	↗
	Serie		104.2
Total		0.0	

<b>40 Skott</b> 	1:	10.1	↑
	2:	*10.3	←
	3:	*10.3	←
	4:	10.1	←
	5:	*10.4	→
	6:	*10.5	↘
	7:	*10.3	↑
	8:	*10.8	↑
	9:	*10.6	↑
	10:	*10.3	↑
	Serie		103.7
Total		103.7	

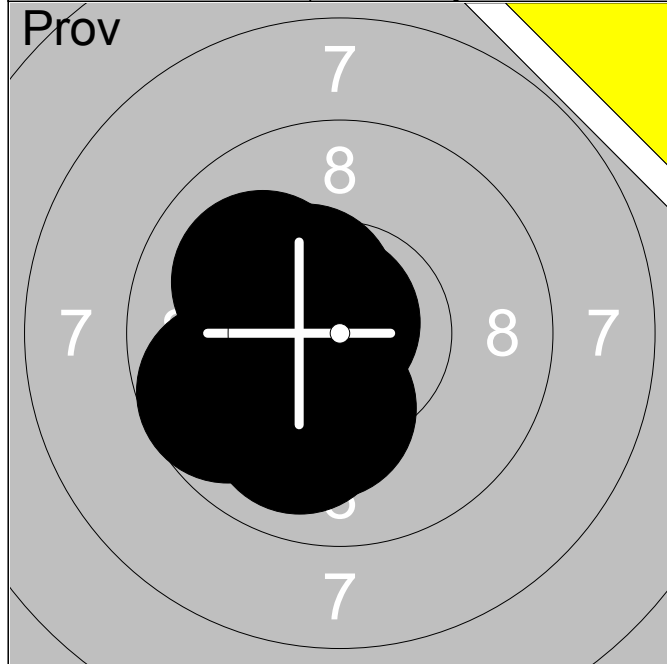

1:	*10.4	↙
2:	10.0	↗
3:	*10.4	↗
4:	*10.3	↖
5:	*10.2	↘
6:	10.0	↘
7:	*10.3	↙
8:	*10.2	↘
9:	9.7	↖
10:	*10.8	↗

Serie	102.3
-------	-------

Total	0.0
-------	-----

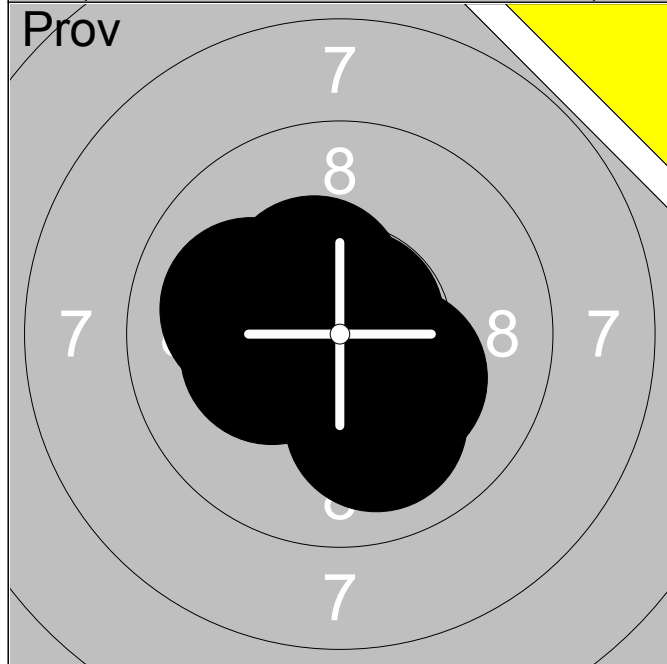

11:	*10.5	↖
12:	*10.7	↘
13:	*10.4	↖
14:	*10.2	↘
15:	10.0	↘
16:	*10.8	↗
17:	10.0	↖
18:	*10.3	↖
19:	*10.4	↗

Serie	93.3
-------	------

Total	0.0
-------	-----

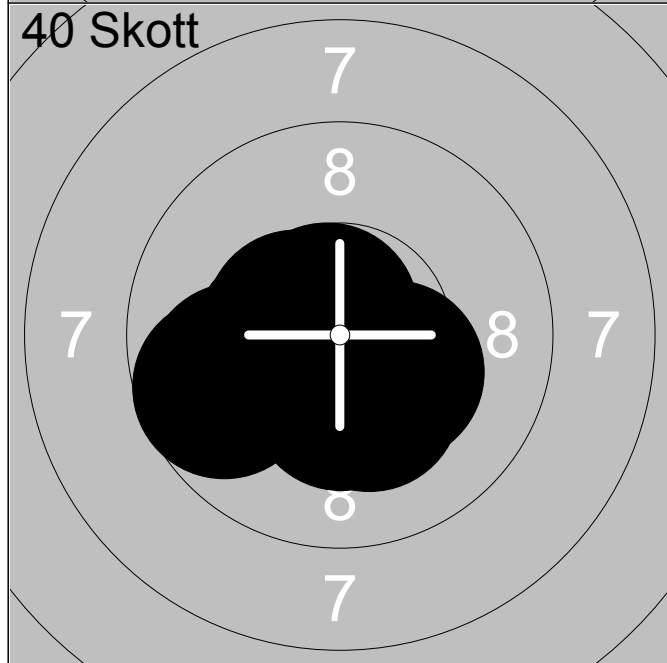

1:	*10.3	↘
2:	*10.7	↗
3:	9.9	↖
4:	*10.3	↘
5:	*10.4	↘
6:	*10.9	↘
7:	*10.5	↖
8:	*10.3	↘
9:	*10.4	↖
10:	9.7	↖

Serie	103.4
-------	-------

Total	103.4
-------	-------

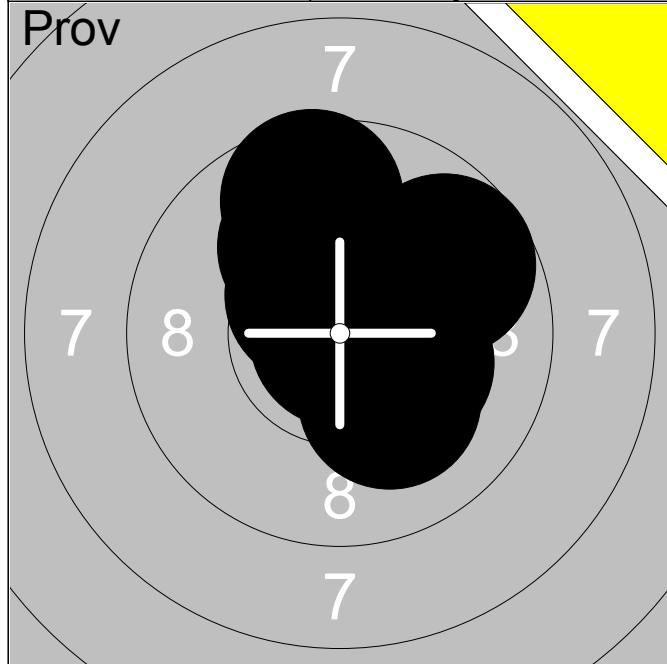

1:	9.7	↗
2:	*10.6	↗
3:	*10.3	→
4:	*10.3	↘
5:	10.1	↘
6:	10.0	↗
7:	*10.5	↗
8:	*10.8	↘
9:	9.6	↗
10:	*10.9	↘

Serie	102.8
-------	-------

Total	0.0
-------	-----

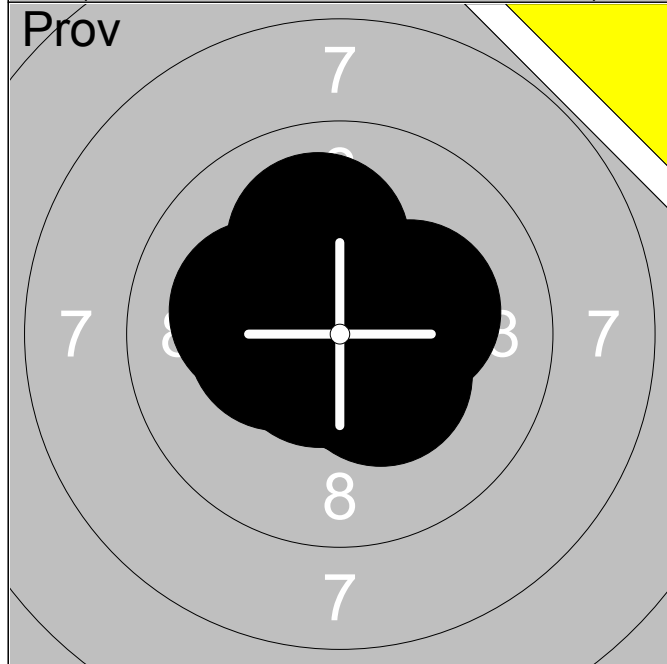

11:	*10.4	↘
12:	*10.7	↘
13:	*10.4	←
14:	10.0	↗
15:	10.1	←
16:	*10.6	↘
17:	*10.7	←
18:	*10.2	→

Serie	83.1
-------	------

Total	0.0
-------	-----

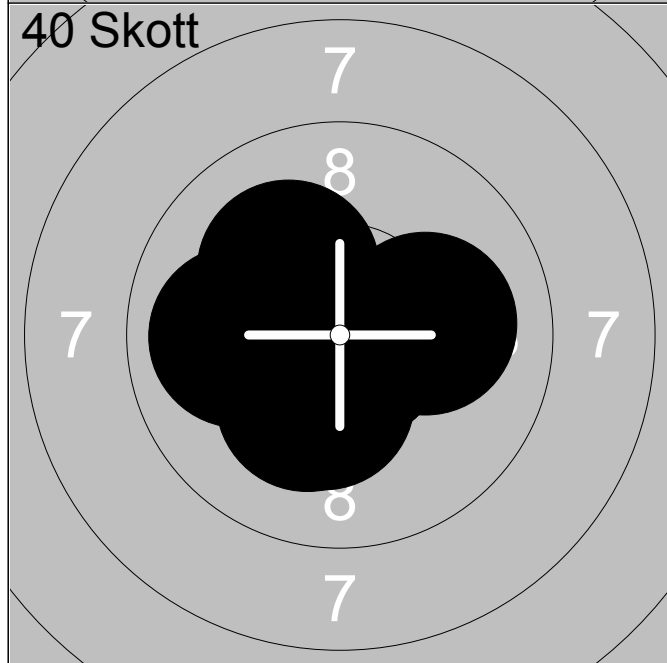

1:	10.1	↗
2:	*10.5	↗
3:	*10.7	↘
4:	10.1	→
5:	*10.2	↘
6:	*10.8	←
7:	10.0	←
8:	*10.3	↘
9:	*10.7	↘
10:	*10.3	↘

Serie	103.7
-------	-------

Total	103.7
-------	-------

Skjutlag <b>4</b>	Tavla <b>28</b>	<b>Carl Bergling</b>
----------------------	--------------------	----------------------

10m	Umeå	Sitt	Vb
-----	------	------	----

02.11.2014	Vindelnskyttet 2014	Ramselefors SKF
------------	---------------------	-----------------

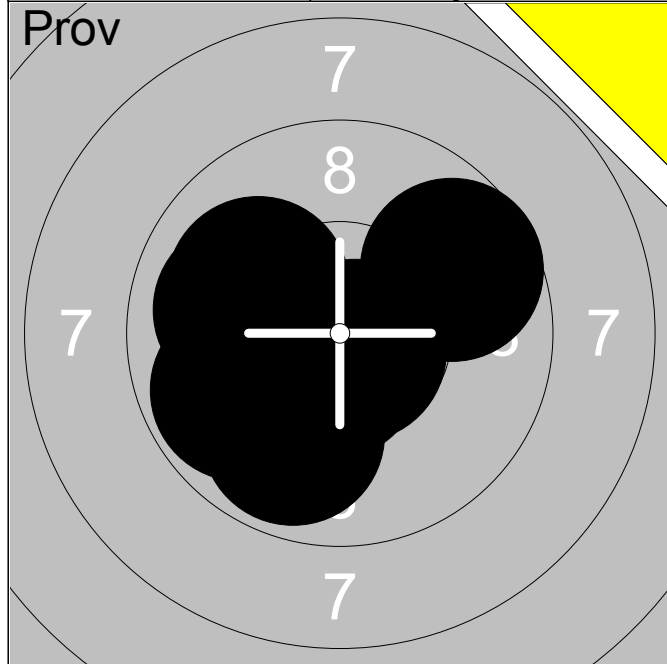

1:	9.9	↙
2:	*10.7	↘
3:	9.8	↙
4:	10.0	↙
5:	10.0	↗
6:	*10.6	↘
7:	9.7	↗
8:	10.0	↙
9:	10.0	↙
10:	*10.6	↙
Serie		101.3
Total		0.0

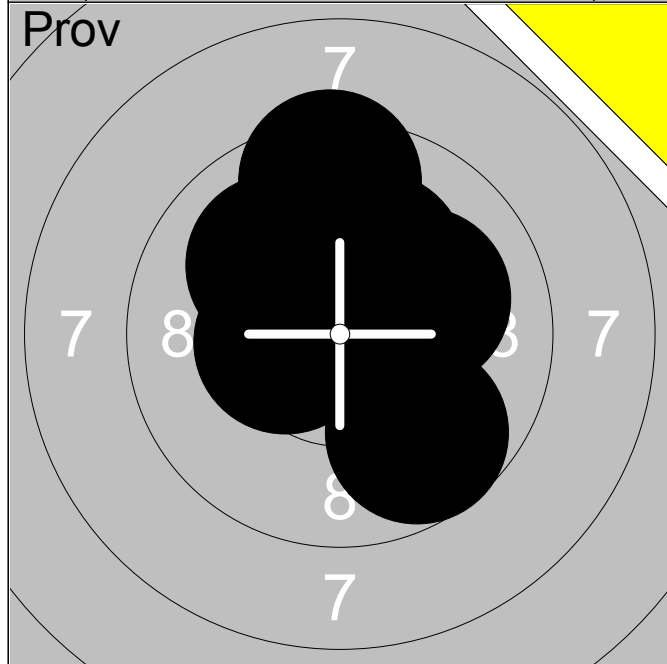

11:	*10.5	↗
12:	*10.6	→
13:	10.0	↗
14:	*10.4	↙
15:	10.1	↗
16:	9.4	↑
17:	*10.4	↗
18:	*10.2	↗
19:	9.7	↘
Serie		91.3
Total		0.0

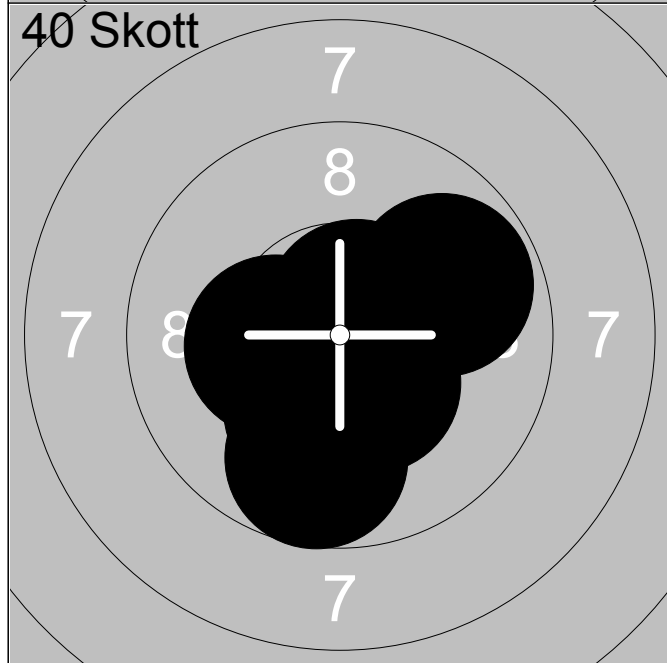

1:	*10.7	↗
2:	*10.2	↘
3:	*10.4	↘
4:	*10.7	↘
5:	*10.9	↗
6:	*10.3	↙
7:	*10.4	↘
8:	*10.5	↙
9:	9.8	↗
10:	9.7	↘
Serie		103.6
Total		103.6





1:	*10.3	←
2:	10.0	↗
3:	*10.4	↖
4:	*10.4	↗
5:	10.1	↗
6:	*10.6	↖
7:	*10.4	→
8:	*10.3	↘
9:	*10.2	←
10:	10.0	↘



Serie	102.7
Total	0.0



1:	*10.4	↙
2:	*10.4	↙
3:	*10.2	↘
4:	9.9	↗
5:	*10.2	↖
6:	9.4	↑
7:	*10.6	↖
8:	10.1	↖
9:	*10.5	↘
10:	*10.7	↗

Serie	102.4
Total	102.4

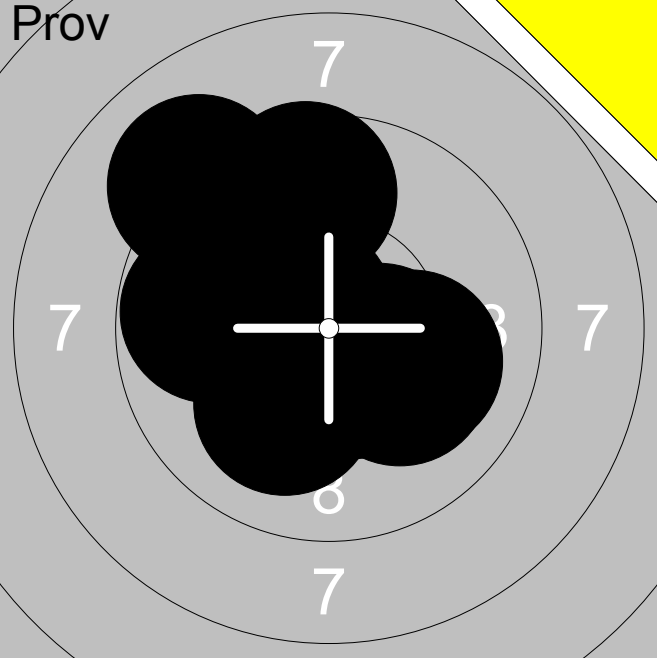

Skjutlag	Tavla	Pea Smeets		
5	21	S.V. De Grensstreek		NED
10m				
02.11.2014	Vindelnskyttet 2014	Ramselefors SKF		
<b>Prov</b> 	1:	*10.5	↙	
	2:	10.1	↙	
	3:	*10.6	↗	
	4:	10.1	↘	
	5:	*10.5	↙	
	6:	10.1	↘	
	7:	9.6	↗	
	8:	9.8	↖	
	9:	*10.4	↘	
	10:	9.1	↗	
	Serie			100.8
Total			0.0	
<b>40 Skott</b> 	1:	*10.3	↘	
	2:	9.6	↗	
	3:	*10.4	↗	
	4:	*10.2	↖	
	5:	9.8	↗	
	6:	*10.6	↖	
	7:	9.6	↗	
	8:	*10.5	↘	
	9:	10.0	↖	
	10:	*10.9	↗	
	Serie			101.9
Total			101.9	
<b>40 Skott</b> 	11:	*10.4	↗	
	12:	9.6	↙	
	13:	9.9	↖	
	14:	*10.8	↘	
	15:	*10.5	↘	
	16:	*10.6	↙	
	17:	*10.8	↘	
	18:	*10.8	↘	
	19:	*10.2	↗	
	20:	9.8	↗	
	Serie			103.4
Total			205.3	



1:	*10.2	↘
2:	*10.4	↙
3:	9.5	↘
4:	*10.6	↗
5:	*10.5	↗
6:	*10.4	↗
7:	*10.4	→
8:	*10.7	↘

Serie	82.7
Total	0.0

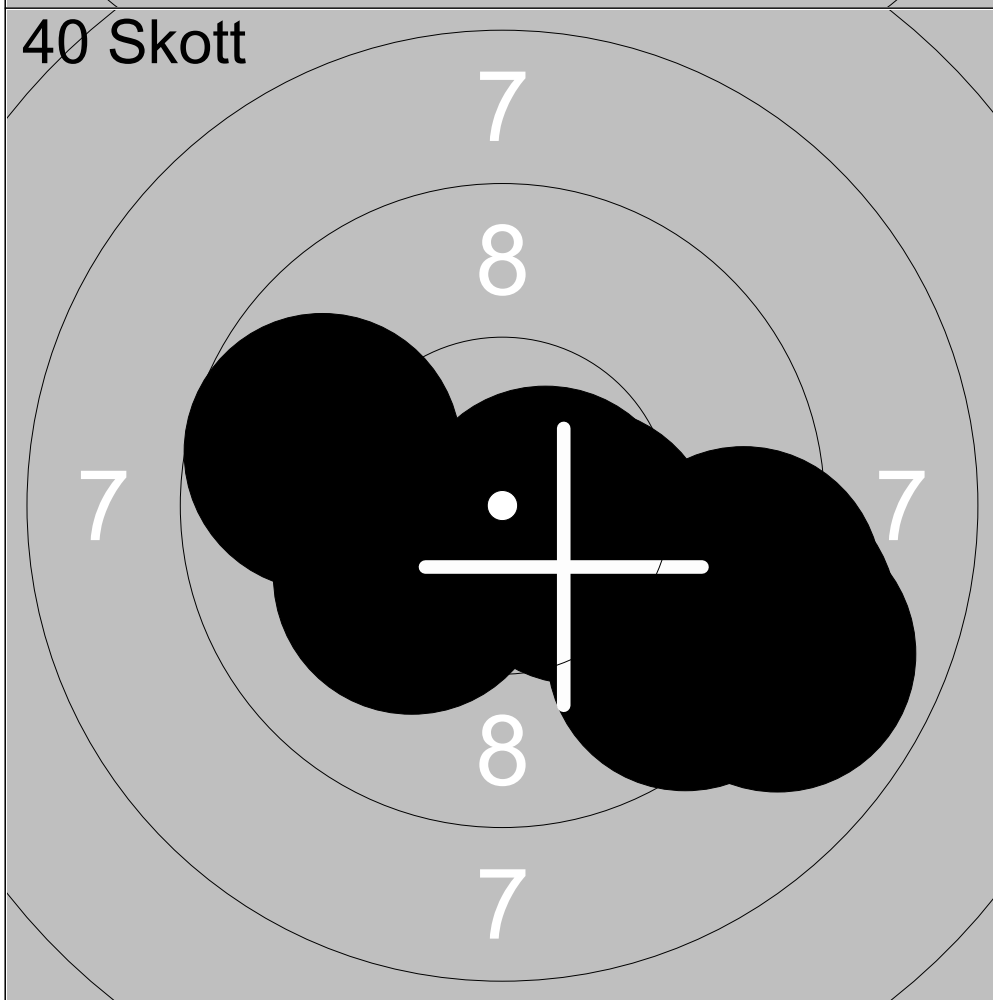

1:	8.9	↘
2:	*10.2	↙
3:	9.4	↘
4:	9.3	↘
5:	9.1	↘
6:	*10.6	↘
7:	9.7	↖
8:	*10.4	↘

Serie	77.6
Total	77.6

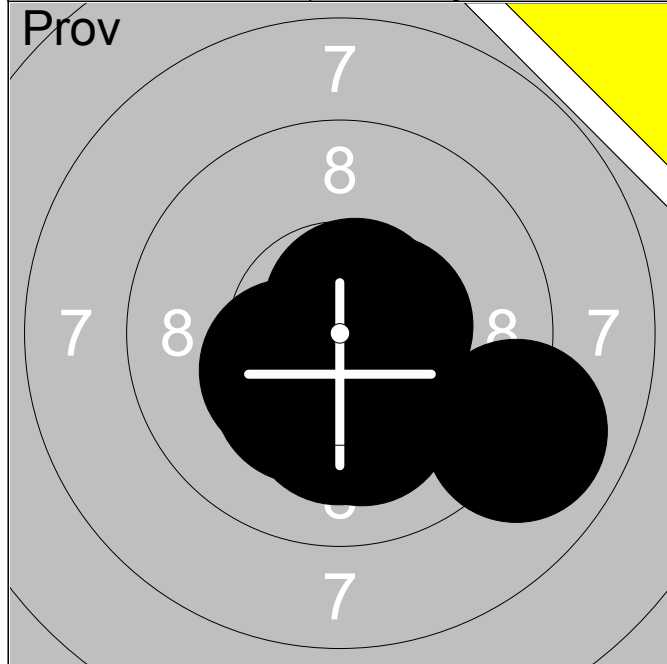

1:	*10.3	↓
2:	9.0	→
3:	*10.3	↙
4:	10.1	↓
5:	*10.2	↓
6:	*10.3	↙
7:	*10.7	↗
8:	*10.5	→
9:	*10.7	↘

Serie	92.1
Total	0.0

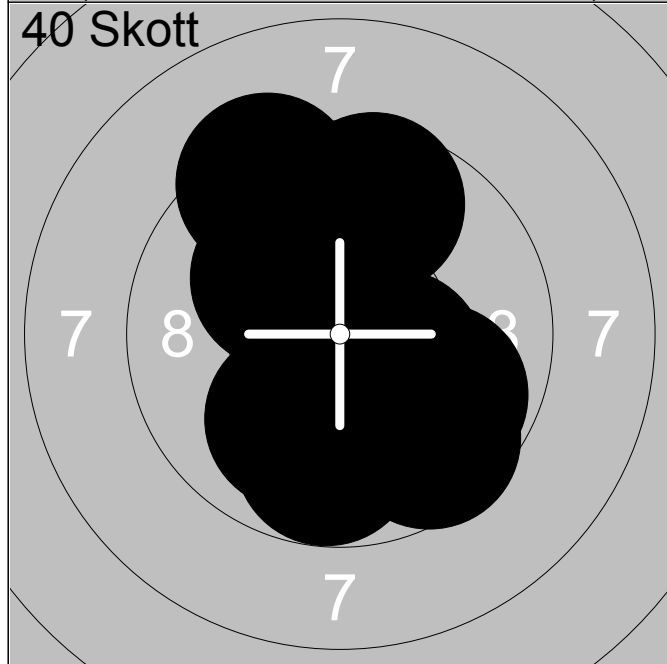

1:	*10.2	↗
2:	*10.4	→
3:	*10.4	↓
4:	9.6	↑
5:	9.6	↓
6:	9.3	↗
7:	10.0	↙
8:	*10.4	↗
9:	9.8	↓
10:	9.8	↘

Serie	99.5
Total	99.5

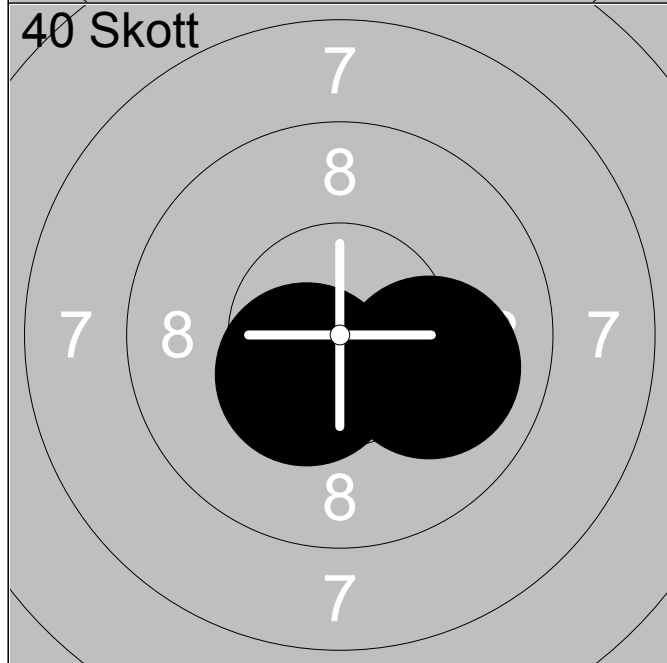

11:	*10.4	↙
12:	10.0	→

Serie	20.4
Total	119.9

<b>Prov</b> 	1:	*10.8	↓
	2:	*10.3	↙
	3:	*10.5	↘
	4:	*10.2	↘
	5:	*10.4	→
	6:	9.8	→
	7:	9.7	↓
	Serie		71.7
Total		0.0	

<b>40 Skott</b> 	1:	9.2	→
	2:	*10.3	↗
	3:	*10.8	←
	4:	9.7	→
	5:	10.0	→
	6:	*10.6	↗
	7:	*10.5	←
	8:	*10.7	↓
	9:	*10.8	↘
	10:	9.7	↘
Serie		102.3	
Total		102.3	

<b>40 Skott</b> 	11:	*10.4	↗
	12:	*10.4	↗
	13:	*10.7	↘
	14:	*10.5	↗
	15:	9.7	→
	16:	10.1	↓
	17:	*10.2	↗
	18:	*10.2	↗
	19:	*10.2	←
	20:	*10.4	↖
Serie		102.8	
Total		205.1	

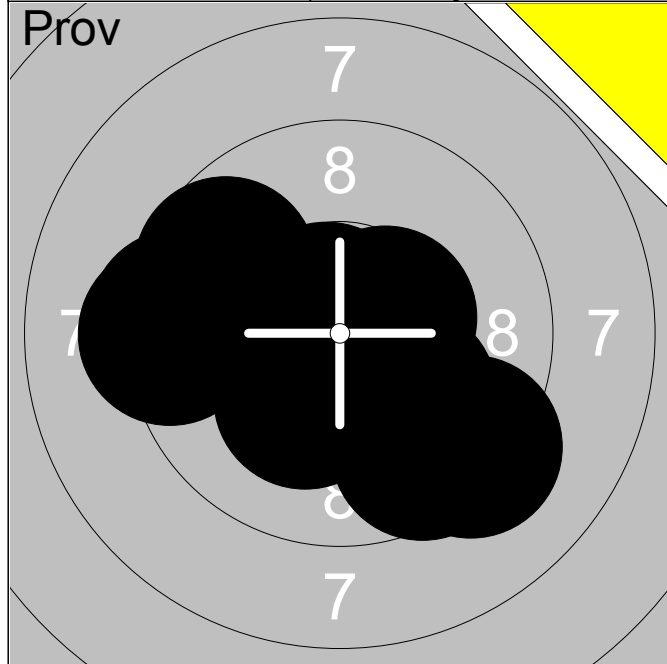

1:	9.3	←
2:	*10.7	↗
3:	9.8	↗
4:	9.4	←
5:	*10.2	↘
6:	10.1	↘
7:	9.7	↗
8:	*10.5	→
9:	9.5	↘
10:	9.2	↘
<b>Serie</b>		<b>98.4</b>
<b>Total</b>		<b>0.0</b>

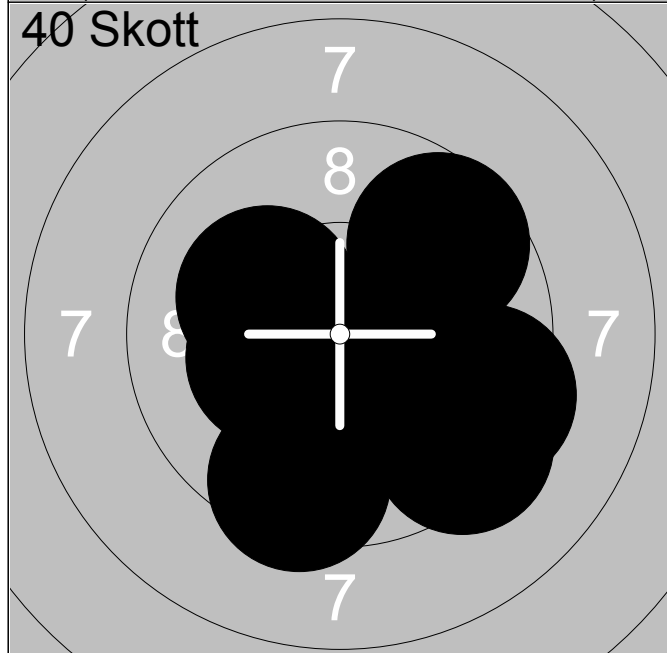

1:	*10.3	→
2:	9.5	↘
3:	*10.3	←
4:	10.1	↗
5:	9.6	↗
6:	9.3	↘
7:	*10.5	↘
8:	*10.6	↘
9:	9.4	→
10:	*10.8	↘
<b>Serie</b>		<b>100.4</b>
<b>Total</b>		<b>100.4</b>

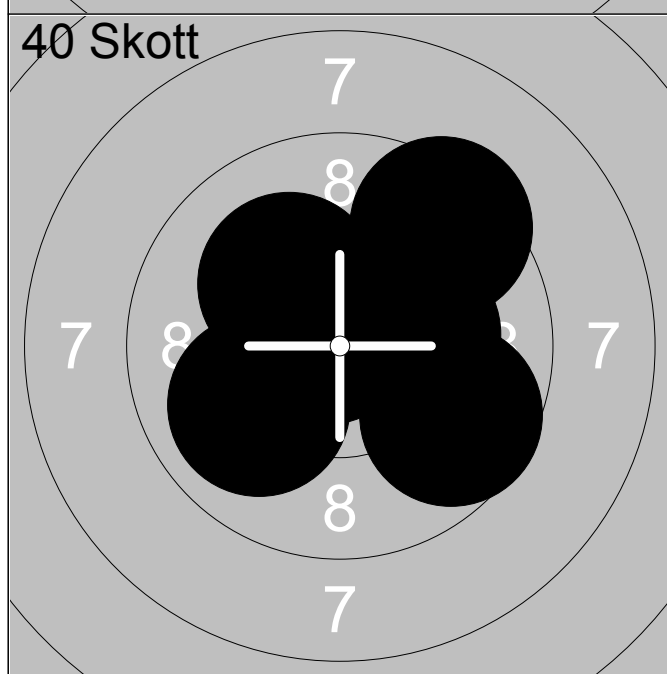

11:	*10.8	↗
12:	*10.2	↗
13:	*10.3	→
14:	9.7	↘
15:	9.4	↗
16:	10.0	↘
<b>Serie</b>		<b>60.4</b>
<b>Total</b>		<b>160.8</b>

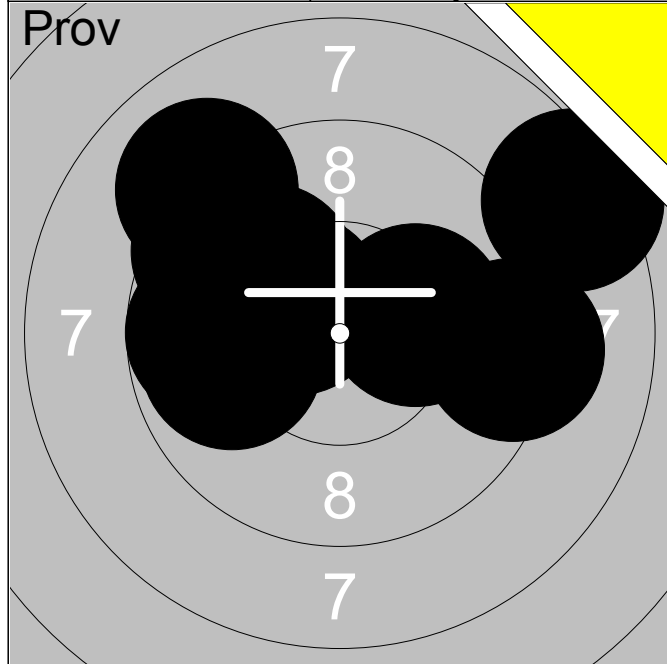

1:	9.2	→
2:	*10.4	↗
3:	9.5	↗
4:	9.7	←
5:	9.0	↗
6:	8.3	↗
7:	9.9	←
8:	*10.2	→
9:	10.0	↗
10:	*10.2	↗
<b>Serie</b>		<b>96.4</b>
<b>Total</b>		<b>0.0</b>

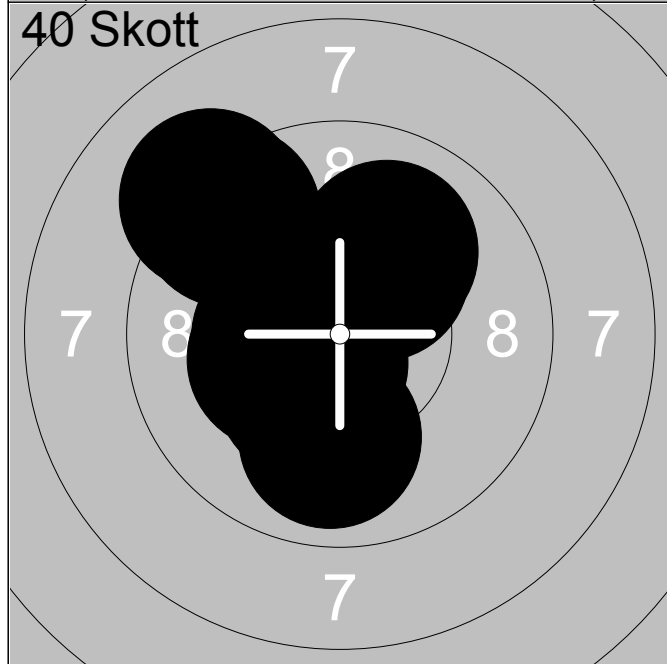

1:	*10.6	↙
2:	9.9	↓
3:	*10.3	↙
4:	*10.4	←
5:	*10.3	←
6:	*10.2	↗
7:	9.4	↗
8:	9.1	↗
9:	10.0	↗
10:	*10.4	←
<b>Serie</b>		<b>100.6</b>
<b>Total</b>		<b>100.6</b>

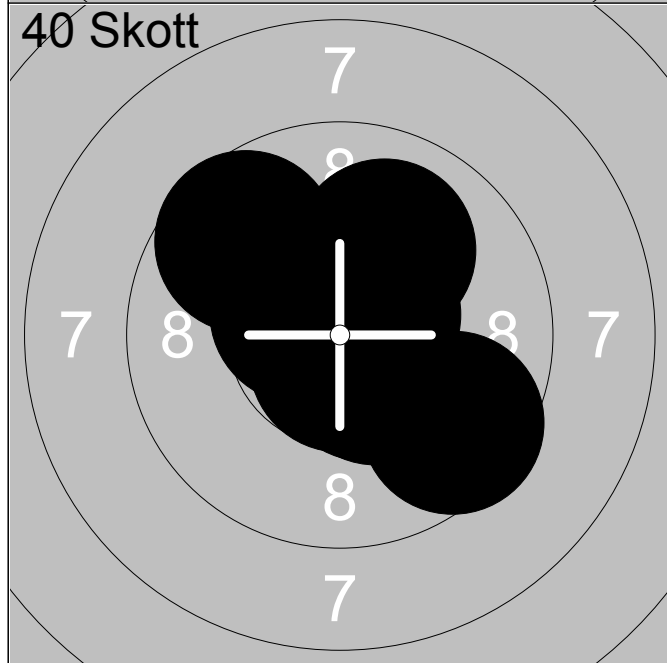

11:	*10.7	↓
12:	9.5	↘
13:	*10.5	↘
14:	9.7	↗
15:	*10.6	↗
16:	10.0	↗
17:	*10.4	↘
18:	*10.5	↗
<b>Serie</b>		<b>81.9</b>
<b>Total</b>		<b>182.5</b>



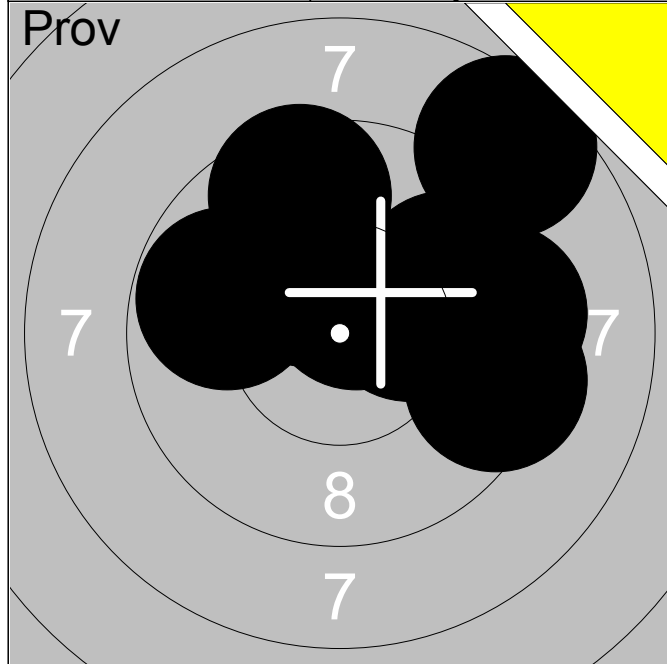

1:	9.4	→
2:	9.8	→
3:	*10.2	→
4:	9.5	↑
5:	8.5	↗
6:	*10.3	↑
7:	9.4	→
8:	9.8	←
9:	*10.6	↗
<b>Serie</b>		<b>87.5</b>
<b>Total</b>		<b>0.0</b>

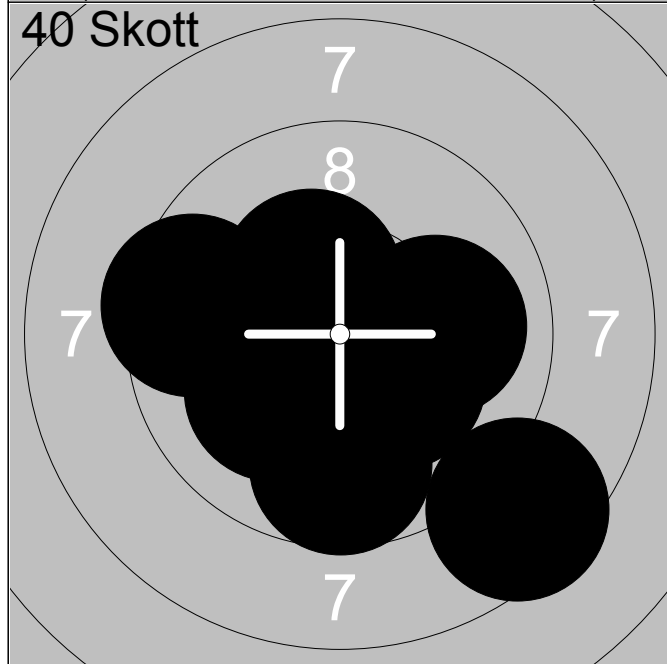

1:	10.0	→
2:	*10.2	↘
3:	*10.8	→
4:	10.1	↙
5:	9.7	↓
6:	*10.4	←
7:	8.5	↘
8:	*10.4	↘
9:	9.5	←
10:	*10.4	↗
<b>Serie</b>		<b>100.0</b>
<b>Total</b>		<b>100.0</b>

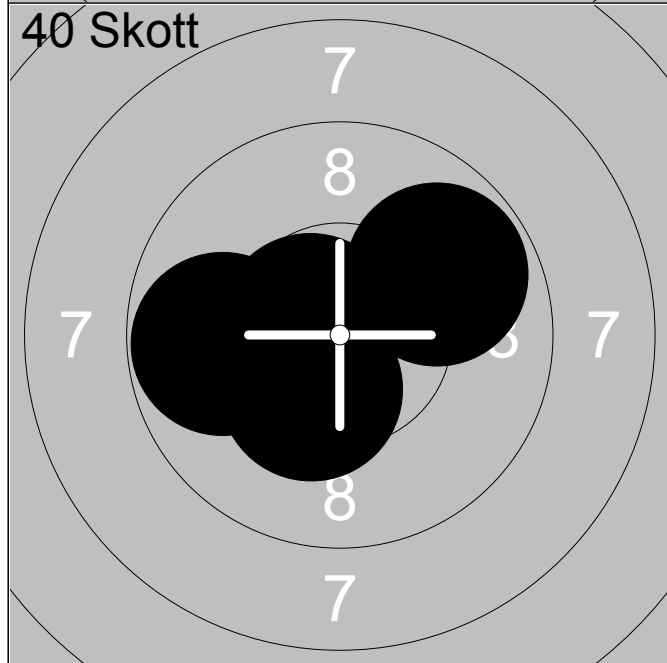

11:	9.8	←
12:	*10.3	↙
13:	*10.6	←
14:	9.8	↗
<b>Serie</b>		<b>40.5</b>
<b>Total</b>		<b>140.5</b>

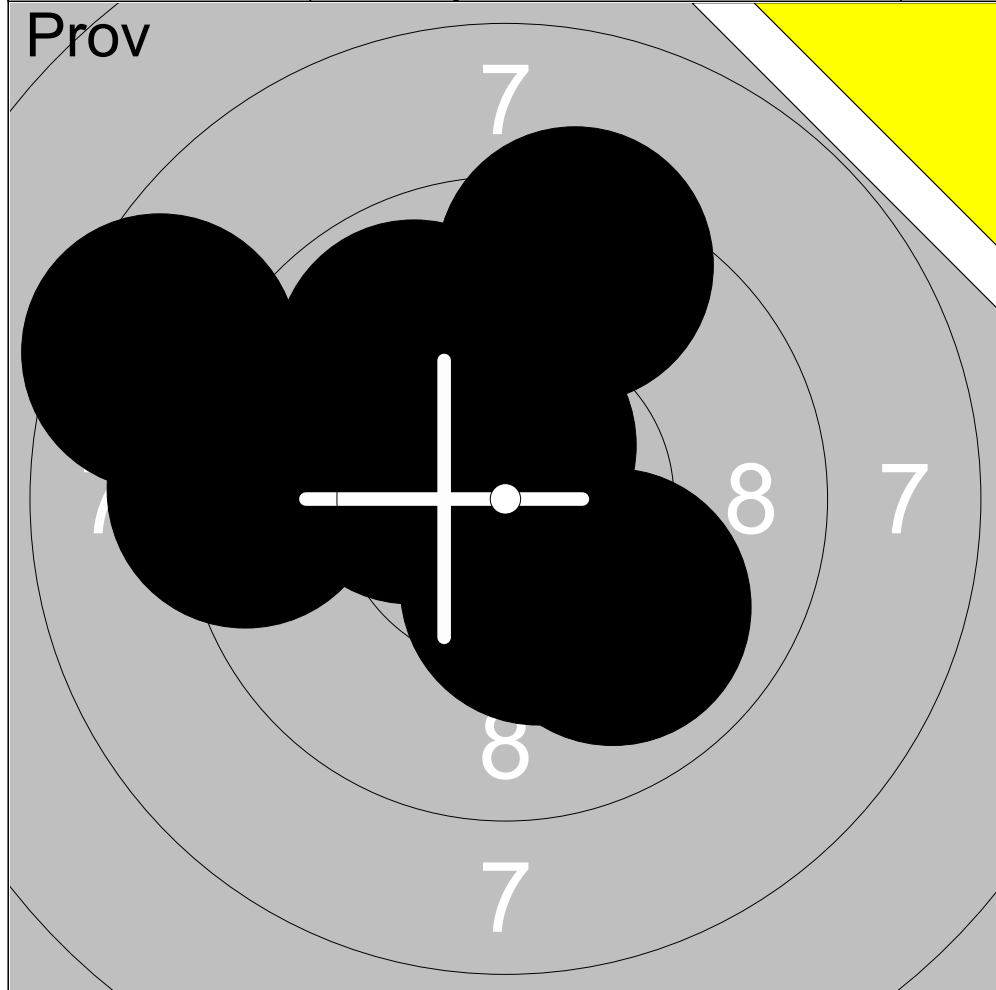

1:	9.3	←
2:	*10.6	↑
3:	8.5	↖
4:	9.9	↗
5:	*10.5	↗
6:	9.4	↗
7:	*10.3	←
8:	10.0	↘
9:	*10.3	↘

Serie	88.8
Total	0.0

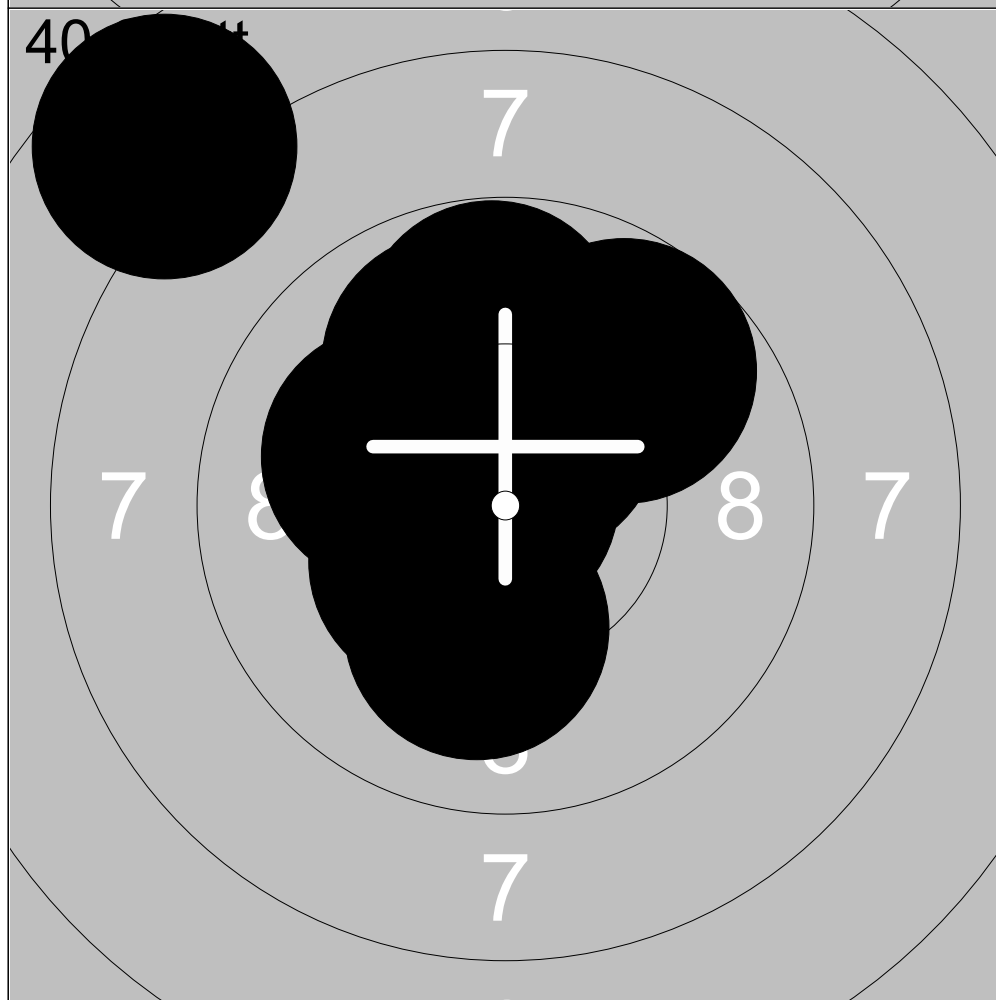

1:	10.1	↘
2:	*10.4	↑
3:	9.7	↗
4:	9.9	↗
5:	9.8	↗
6:	*10.8	←
7:	*10.5	←
8:	7.6	↗
9:	10.1	←
10:	*10.4	↘

Serie	99.3
Total	99.3