

5 Skott Prov

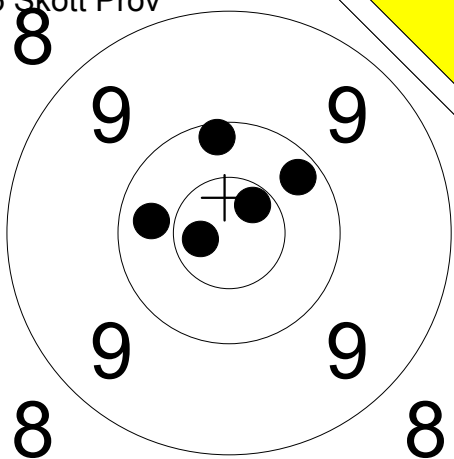

- 1: *10.6 ↗
- 2: 10.2 ↗
- 3: 10.1 ↑
- 4: *10.7 ←
- 5: 10.3 ←

Serie 50.0
Total 0.0

1. Serie 5 Skott

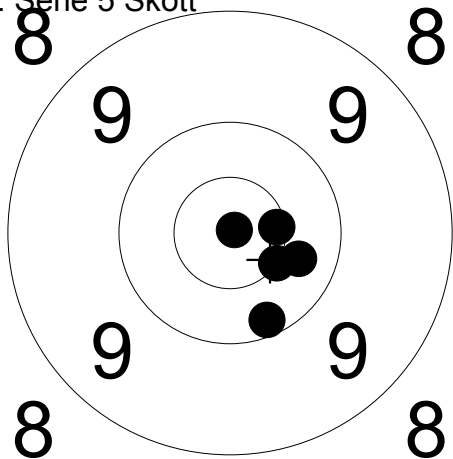

- 1: *10.9 ↗
- 2: *10.5 ↘
- 3: 10.3 →
- 4: 10.2 ↓
- 5: *10.6 →

Serie 50.0
Total 50.0

2. Serie 5 Skott

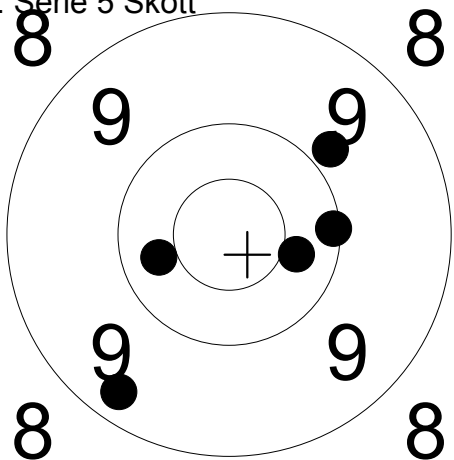

- 1: 10.3 ←
- 2: 10.4 →
- 3: 10.1 →
- 4: 9.8 ↗
- 5: 9.3 ↓

Serie 48.0
Total 98.0

3. Serie 5 Skott

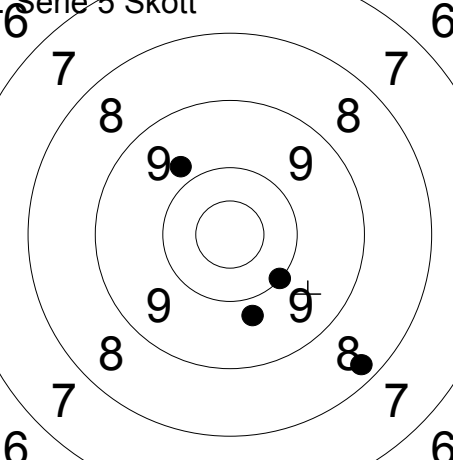

- 1: 10.0 ↘
- 2: 8.3 ↘
- 3: 9.8 ↘
- 4: 9.8 ↗
- 5: 7.1 ↓

Serie 43.0
Total 141.0

Prov

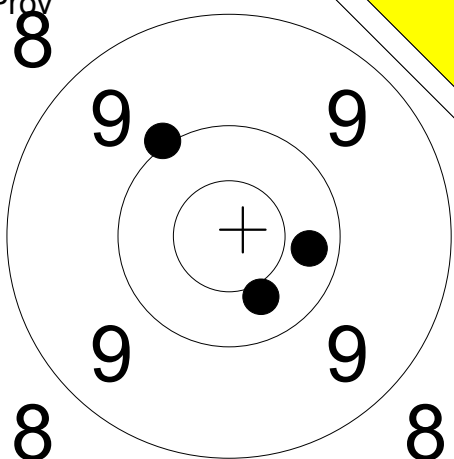

- 1: 10.0 ↗
- 2: 10.3 →
- 3: 10.4 ↓

Serie 30.0
Total 141.0

1. Serie 5 Skott

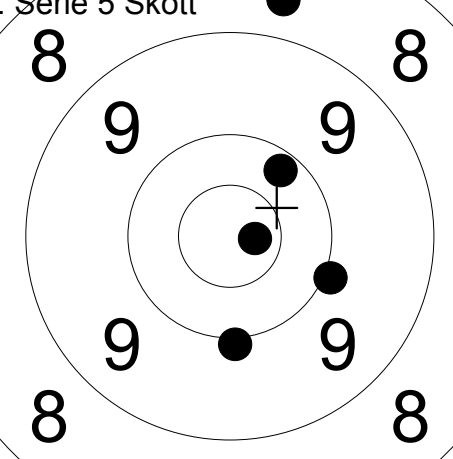

- 1: 8.7 ↑
- 2: *10.7 →
- 3: 10.2 ↗
- 4: 10.0 ↓
- 5: 10.0 ↘

Serie 48.0
Total 189.0

2. Serie 5 Skott

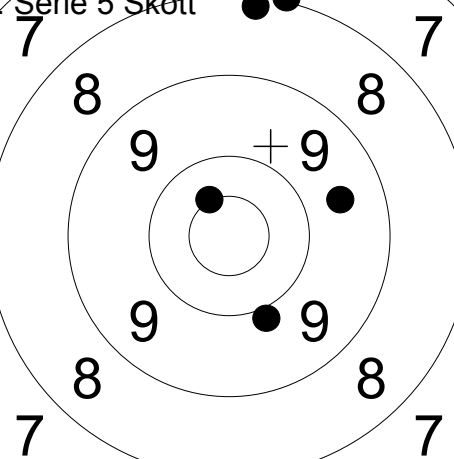

- 1: 9.6 →
- 2: *10.5 ↗
- 3: 9.9 ↘
- 4: 8.2 ↑
- 5: 8.0 ↑

Serie 44.0
Total 233.0

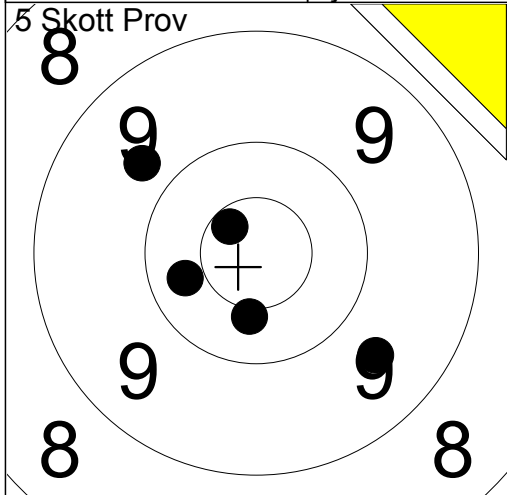

1:	*10.4	↓
2:	9.7	↗
3:	10.3	↖
4:	*10.6	↗
5:	9.6	↓
Serie		48.0
Total		0.0

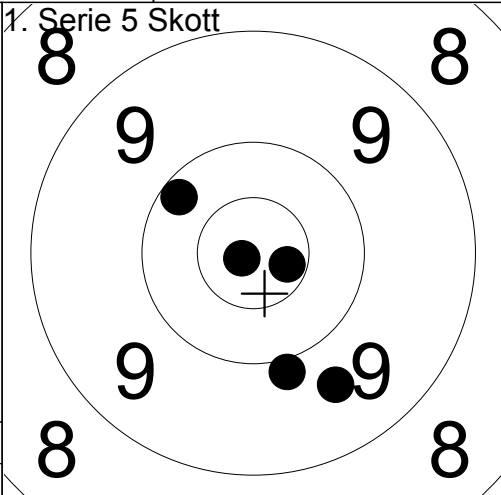

1:	9.9	↓
2:	9.6	↓
3:	*10.8	↖
4:	10.2	↗
5:	*10.7	↘
Serie		48.0
Total		48.0

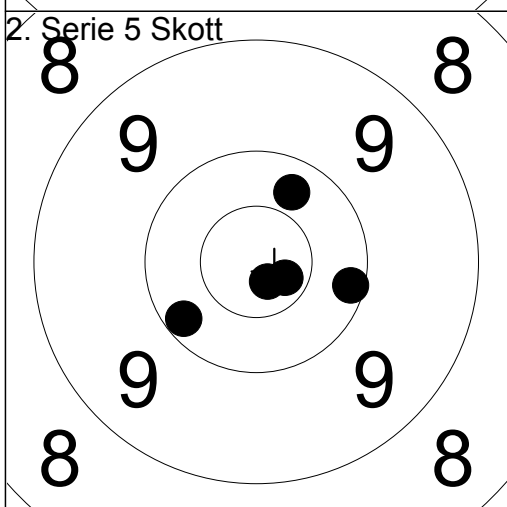

1:	*10.7	↘
2:	10.2	↖
3:	10.3	↗
4:	10.1	→
5:	*10.8	↓
Serie		50.0
Total		98.0

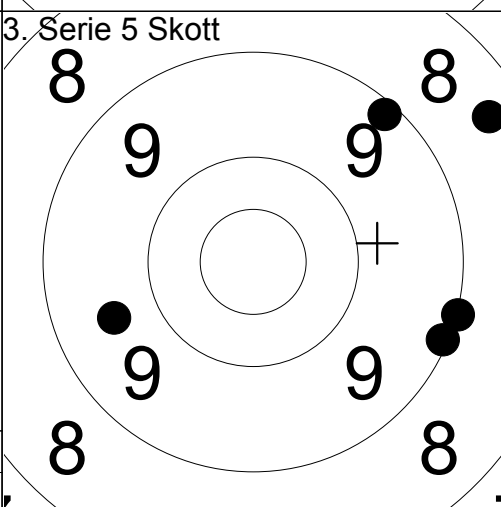

1:	9.1	→
2:	9.2	↗
3:	9.6	↖
4:	8.4	↗
5:	9.0	→
Serie		44.0
Total		142.0

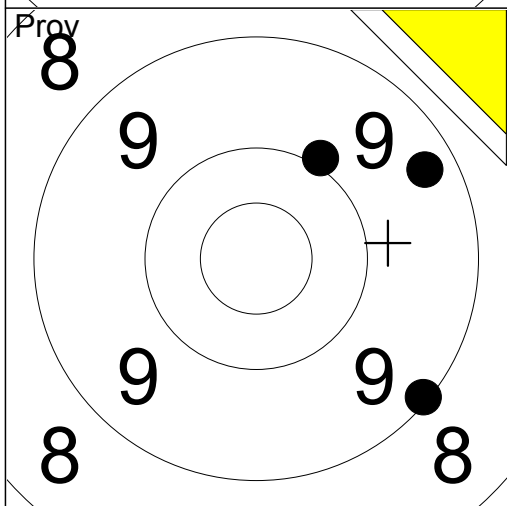

1:	10.0	↗
2:	9.3	↗
3:	9.1	↘
Serie		28.0
Total		142.0

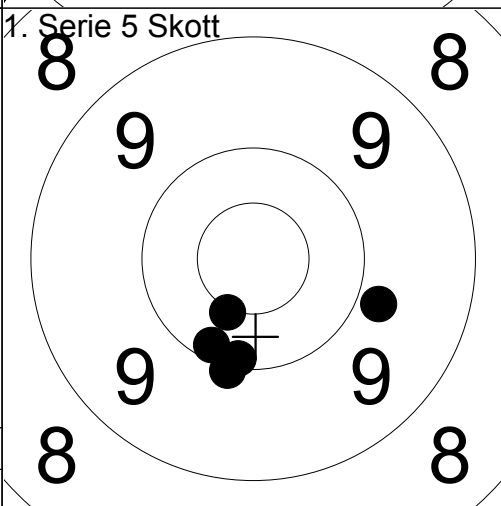

1:	10.0	↓
2:	10.2	↓
3:	*10.5	↓
4:	10.1	↓
5:	9.8	→
Serie		49.0
Total		191.0

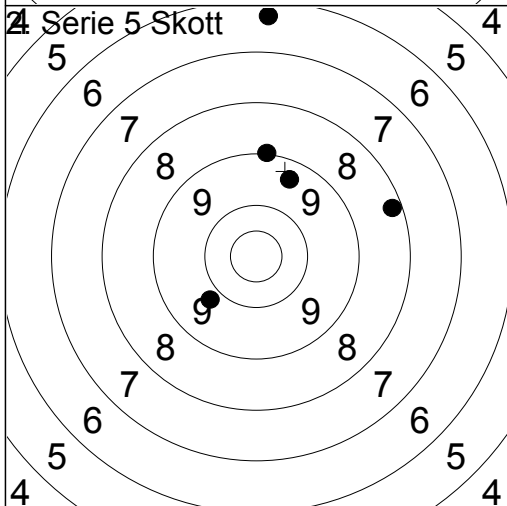

1:	8.2	→
2:	9.4	↗
3:	9.8	↖
4:	6.3	↑
5:	9.0	↑
Serie		41.0
Total		232.0

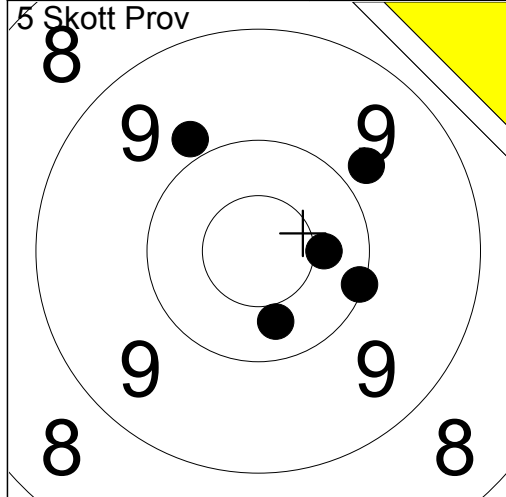

1:	10.3	↘
2:	9.9	↗
3:	9.8	↗
4:	10.4	→
5:	10.1	↘

Serie	48.0
Total	0.0

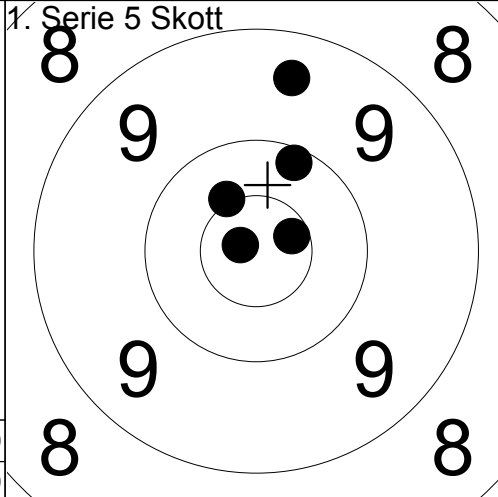

1:	*10.4	↗
2:	9.4	↑
3:	*10.8	↖
4:	*10.6	→
5:	10.2	↑

Serie	49.0
Total	49.0

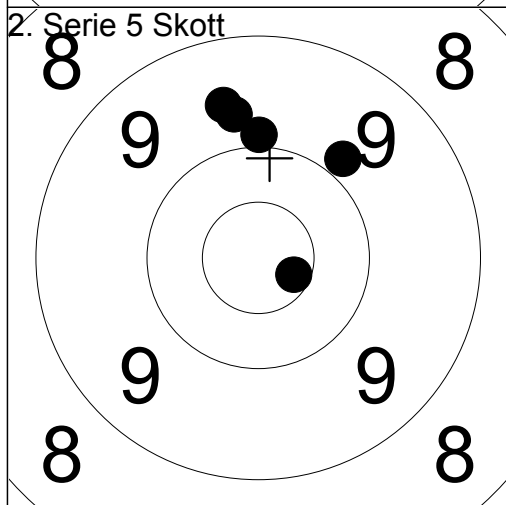

1:	9.7	↑
2:	9.9	↗
3:	*10.6	↘
4:	9.6	↑
5:	9.9	↑

Serie	46.0
Total	95.0

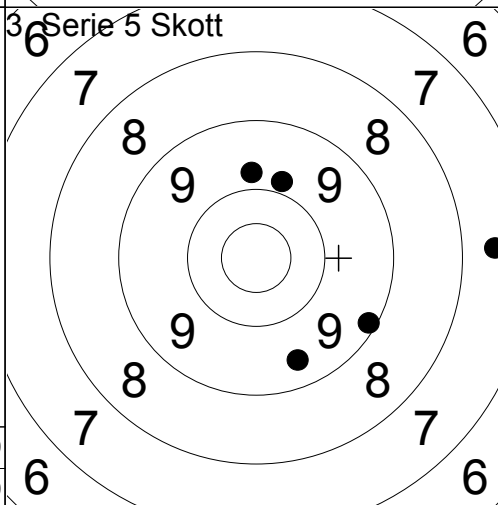

1:	9.1	⇒
2:	9.4	↘
3:	9.9	↑
4:	9.8	↑
5:	7.6	→

Serie	43.0
Total	138.0

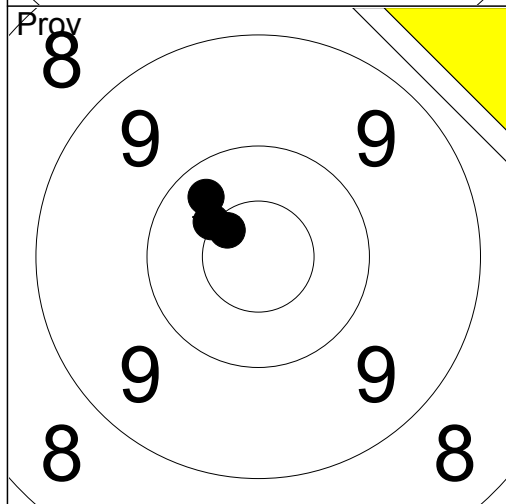

1:	*10.5	↗
2:	10.3	↗
3:	*10.6	↗

Serie	30.0
Total	138.0

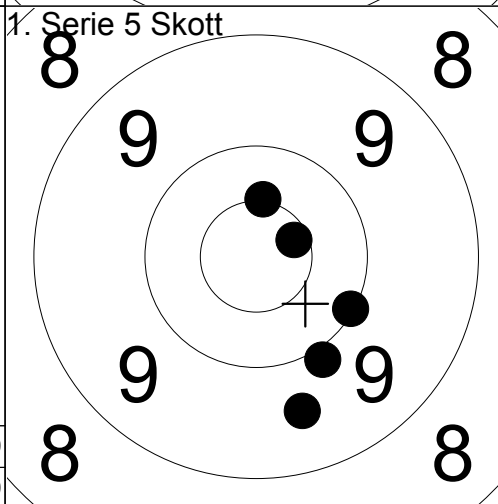

1:	*10.5	↑
2:	9.6	↘
3:	10.0	⇒
4:	9.9	↘
5:	*10.6	→

Serie	48.0
Total	186.0

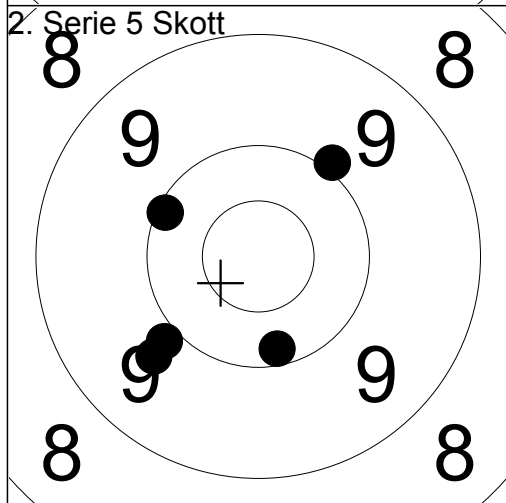

1:	9.9	↖
2:	10.2	↘
3:	9.7	↖
4:	10.1	↖
5:	10.0	↗

Serie	48.0
Total	234.0

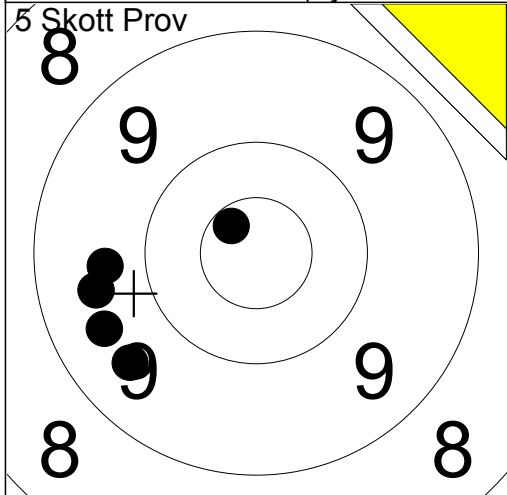

1:	9.6	←
2:	9.5	↙
3:	9.5	↙
4:	*10.6	↗
5:	9.7	←
Serie		46.0
Total		0.0

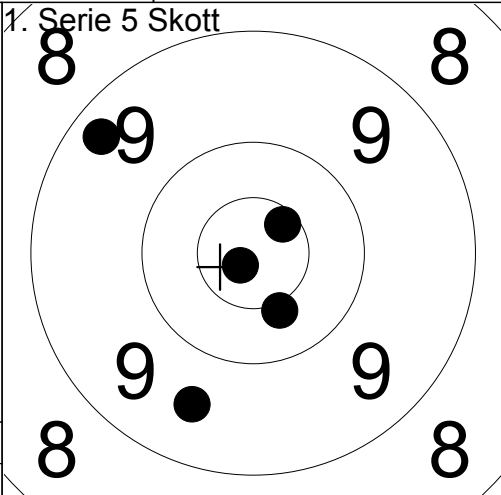

1:	9.6	↘
2:	*10.4	↘
3:	*10.8	↙
4:	9.3	↗
5:	*10.6	↗
Serie		48.0
Total		48.0

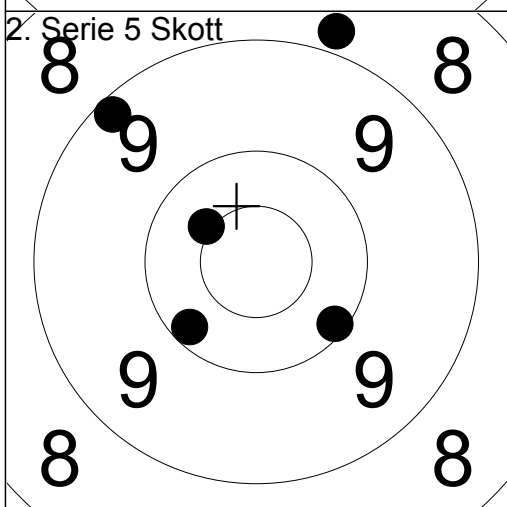

1:	10.2	↙
2:	9.2	↗
3:	10.1	↘
4:	8.8	↗
5:	*10.4	↗
Serie		47.0
Total		95.0

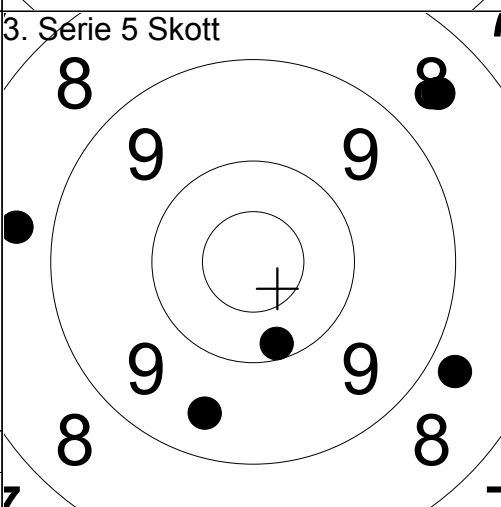

1:	8.7	←
2:	10.2	↘
3:	9.5	↘
4:	8.8	↗
5:	8.6	↗
Serie		43.0
Total		138.0

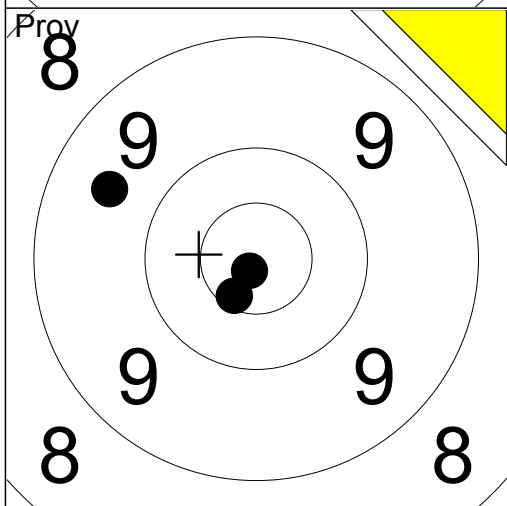

1:	9.6	↙
2:	*10.8	↘
3:	*10.6	↘
Serie		29.0
Total		138.0

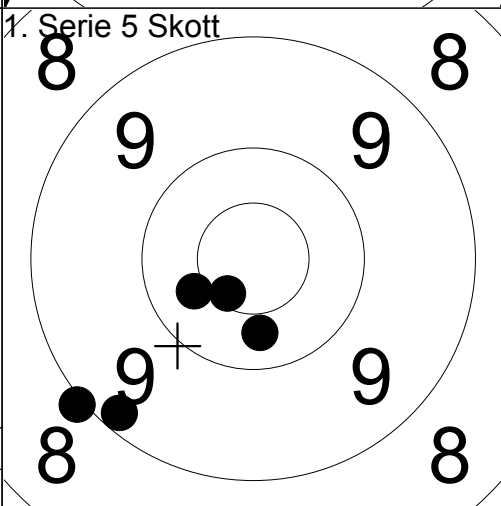

1:	10.3	↘
2:	9.0	↙
3:	10.4	↙
4:	*10.6	↘
5:	9.2	↘
Serie		48.0
Total		186.0

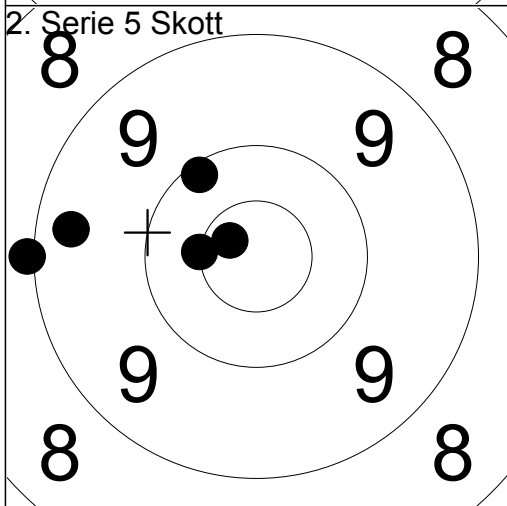

1:	9.0	←
2:	*10.5	←
3:	*10.7	↗
4:	9.3	←
5:	10.1	↗
Serie		48.0
Total		234.0

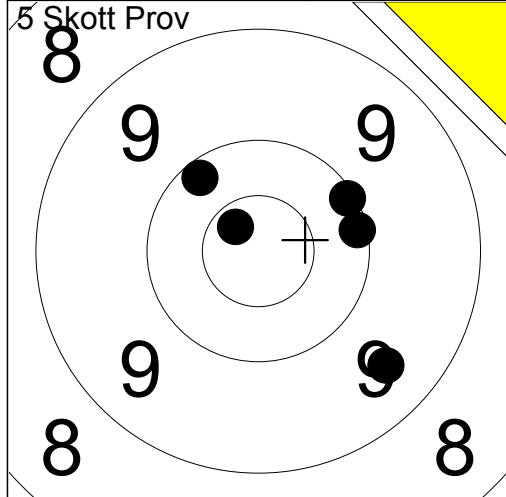

1:	10.1	↗
2:	*10.7	↗
3:	10.2	↗
4:	10.1	→
5:	9.5	↘
Serie		49.0
Total		0.0

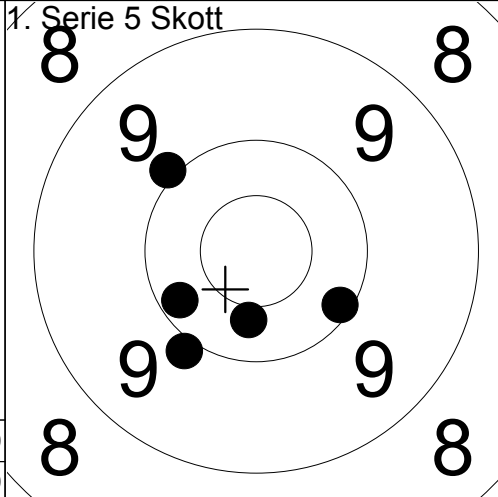

1:	10.0	↗
2:	9.9	↘
3:	10.1	↘
4:	10.2	↘
5:	10.4	↘
Serie		49.0
Total		49.0

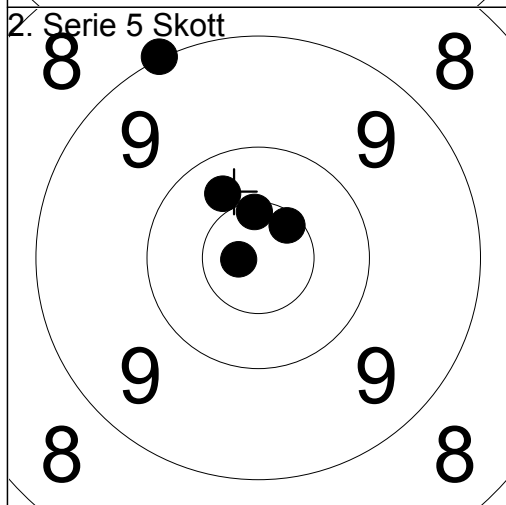

1:	9.0	↖
2:	*10.8	←
3:	*10.6	↑
4:	*10.6	↗
5:	10.3	↗
Serie		49.0
Total		98.0

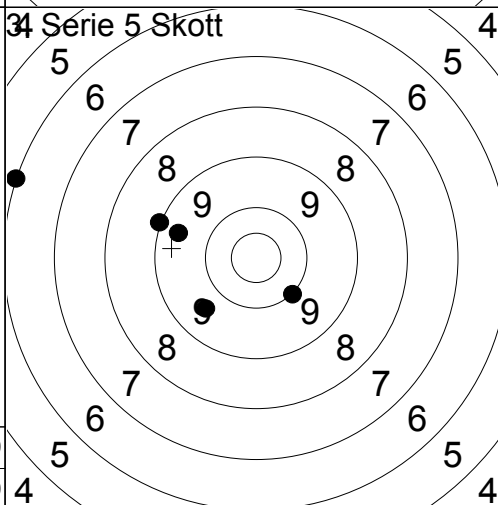

1:	9.0	↖
2:	9.6	↘
3:	10.0	↘
4:	6.0	↖
5:	9.4	↖
Serie		43.0
Total		141.0

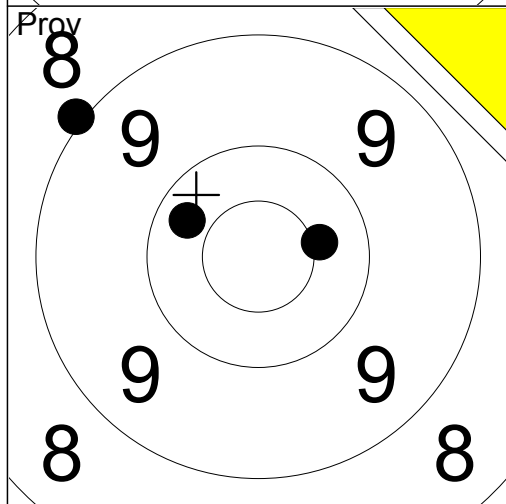

1:	9.0	↖
2:	*10.4	→
3:	10.3	↖
Serie		29.0
Total		141.0

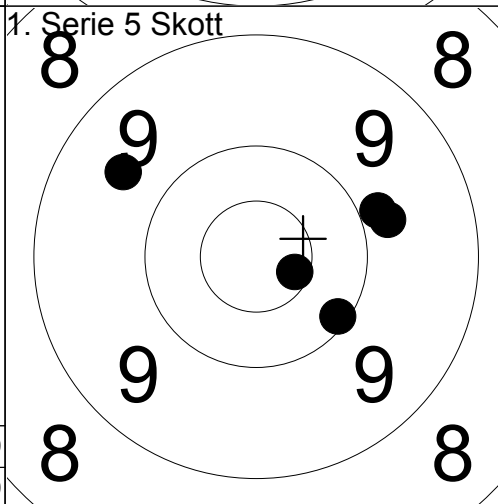

1:	*10.6	↗
2:	9.8	→
3:	10.1	↘
4:	9.6	↖
5:	9.9	↗
Serie		47.0
Total		188.0

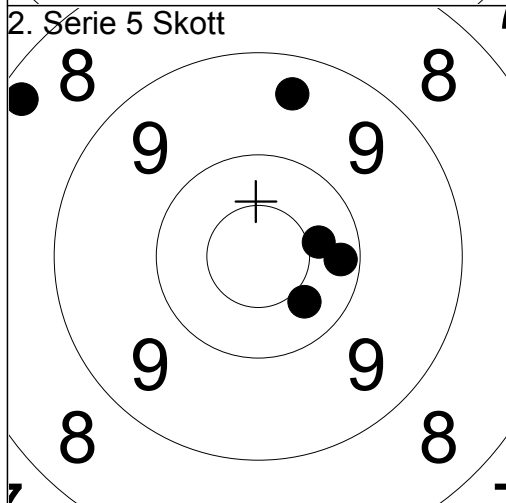

1:	9.4	↑
2:	10.2	→
3:	10.4	↘
4:	10.4	→
5:	8.3	↖
Serie		47.0
Total		235.0

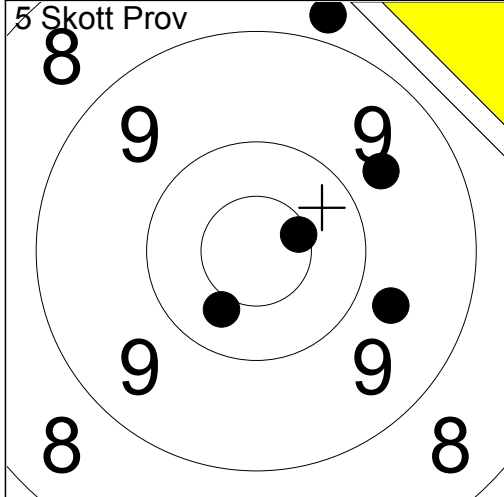

1:	10.4	↙
2:	8.8	↑
3:	*10.6	→
4:	9.7	↗
5:	9.7	↘

Serie	46.0
Total	0.0

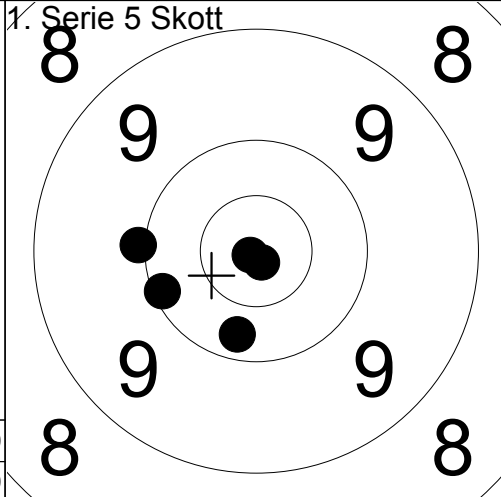

1:	10.1	↙
2:	10.0	←
3:	*10.9	↙
4:	*10.8	↘
5:	10.2	↘

Serie	50.0
Total	50.0

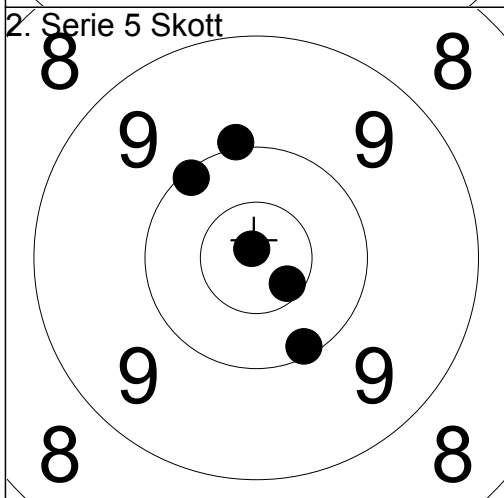

1:	10.0	↑
2:	10.1	↘
3:	10.1	↗
4:	*10.6	↘
5:	*10.9	↗

Serie	50.0
Total	100.0

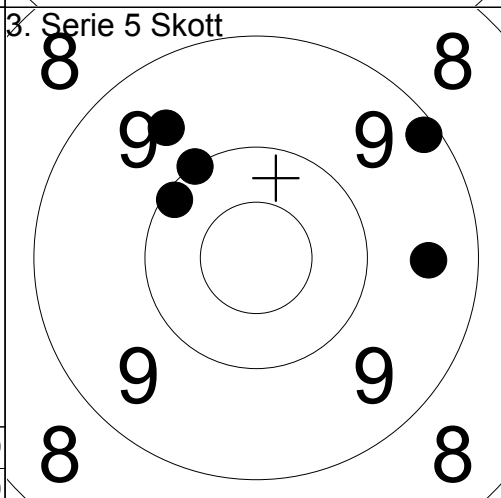

1:	10.0	↗
2:	10.1	↗
3:	9.2	↗
4:	9.5	→
5:	9.6	↗

Serie	47.0
Total	147.0

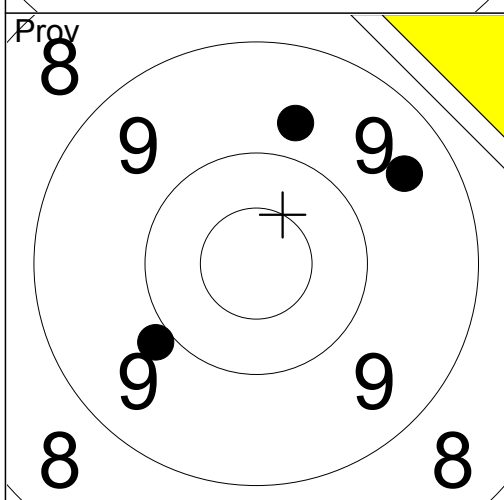

1:	9.9	↙
2:	9.5	↗
3:	9.7	↑

Serie	27.0
Total	147.0

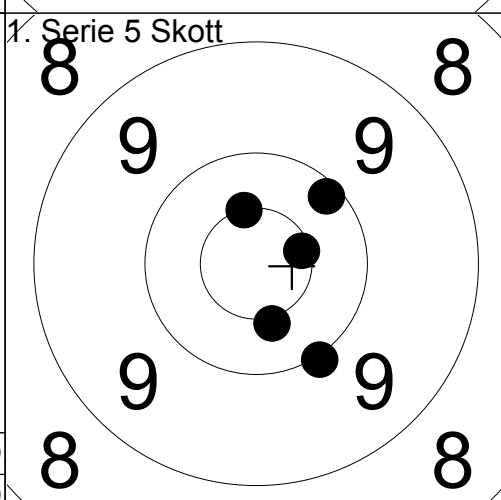

1:	*10.5	↑
2:	*10.4	↘
3:	10.1	↗
4:	*10.6	→
5:	10.0	↘

Serie	50.0
Total	197.0

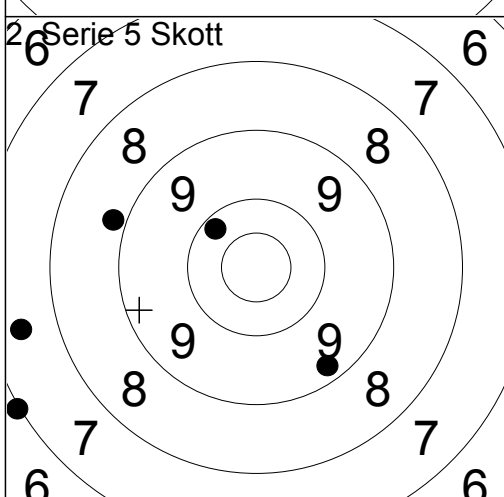

1:	9.3	↘
2:	10.2	↗
3:	8.8	↖
4:	7.5	←
5:	7.0	↙

Serie	41.0
Total	238.0

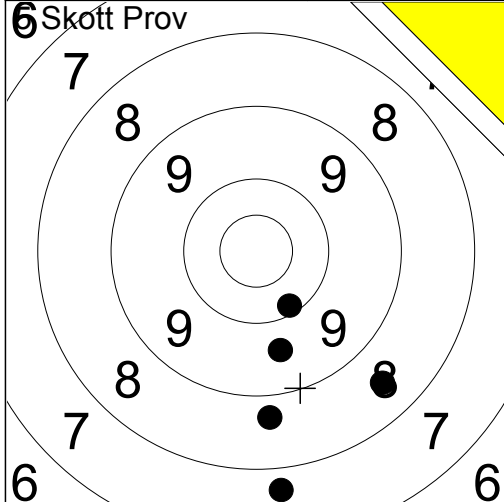

1:	7.7	↓
2:	9.6	↓
3:	8.7	↓
4:	10.1	↓
5:	8.5	↓

Serie	42.0
Total	0.0

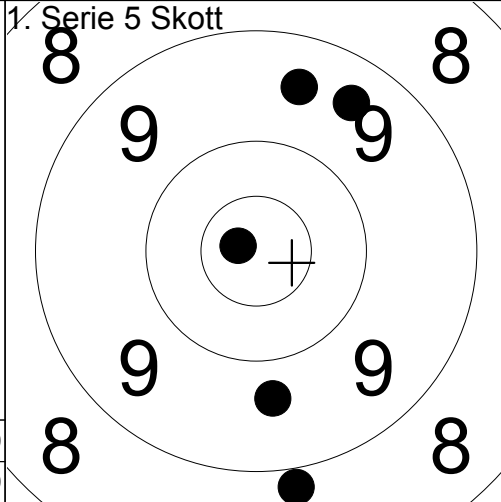

1:	9.7	↓
2:	8.9	↓
3:	*10.8	←
4:	9.5	↑
5:	9.4	↗

Serie	45.0
Total	45.0

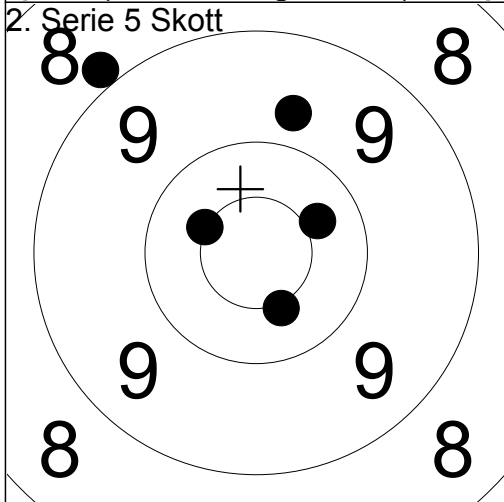

1:	*10.5	←
2:	9.7	↑
3:	8.9	↗
4:	*10.4	↓
5:	10.4	↗

Serie	47.0
Total	92.0

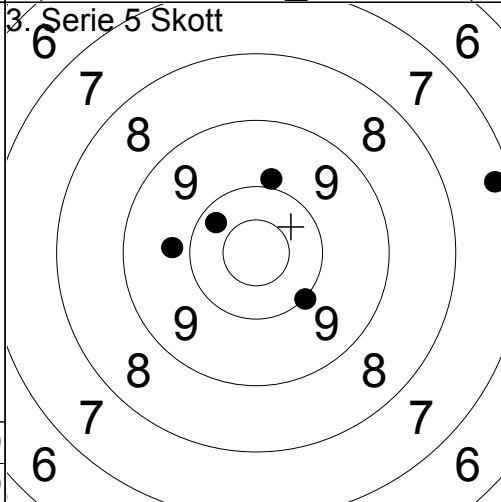

1:	7.3	→
2:	9.9	↑
3:	10.0	↘
4:	9.8	←
5:	10.3	↖

Serie	45.0
Total	137.0

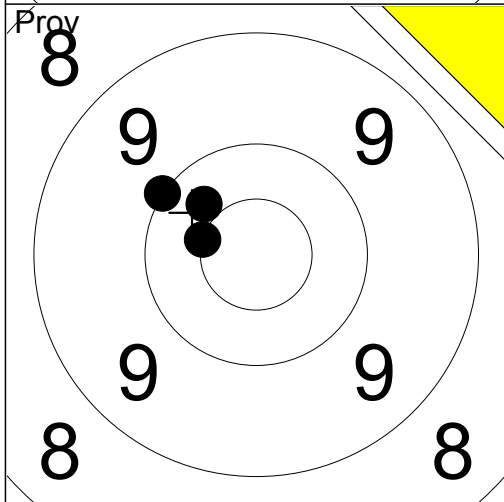

1:	10.3	↗
2:	*10.5	←
3:	10.0	↗

Serie	30.0
Total	137.0

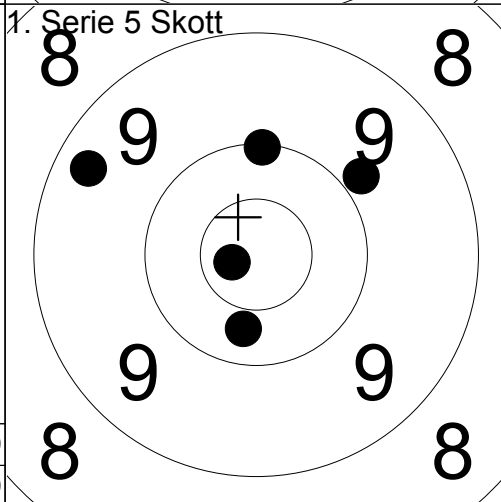

1:	*10.7	←
2:	10.1	↑
3:	10.3	↓
4:	9.3	↖
5:	9.9	↗

Serie	48.0
Total	185.0

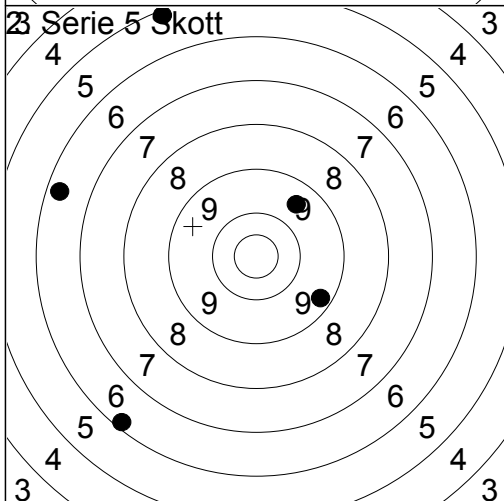

1:	9.5	↗
2:	9.3	↘
3:	6.2	↘
4:	5.2	↑
5:	6.3	←

Serie	35.0
Total	220.0

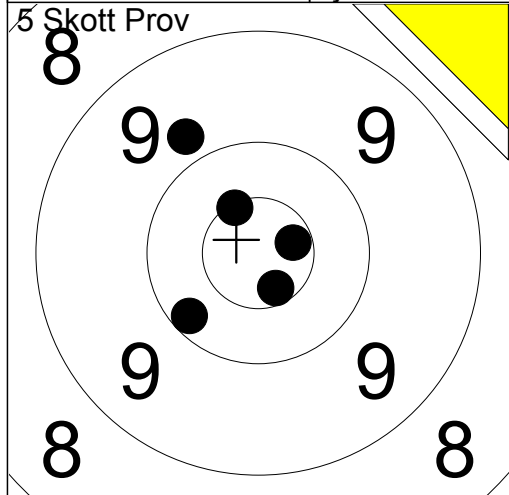

1:	10.2	↙
2:	9.8	↗
3:	*10.5	↗
4:	*10.6	→
5:	*10.6	↘
Serie		49.0
Total		0.0

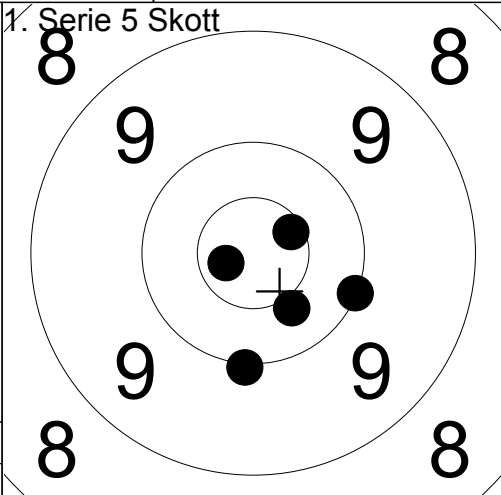

1:	10.0	↓
2:	*10.7	←
3:	10.4	↘
4:	10.0	↘
5:	*10.6	↗
Serie		50.0
Total		50.0

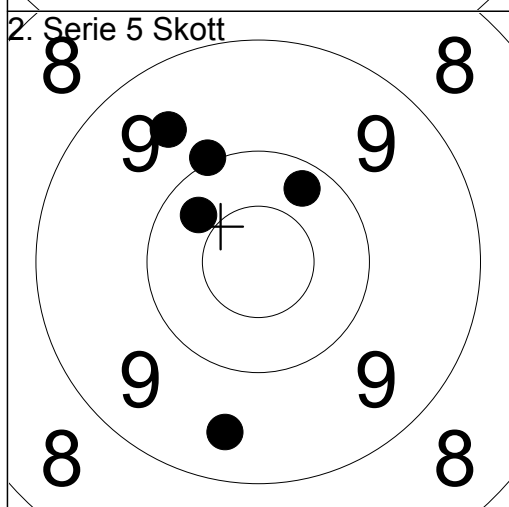

1:	9.6	↗
2:	10.0	↗
3:	10.2	↗
4:	9.5	↘
5:	10.3	↗
Serie		48.0
Total		98.0

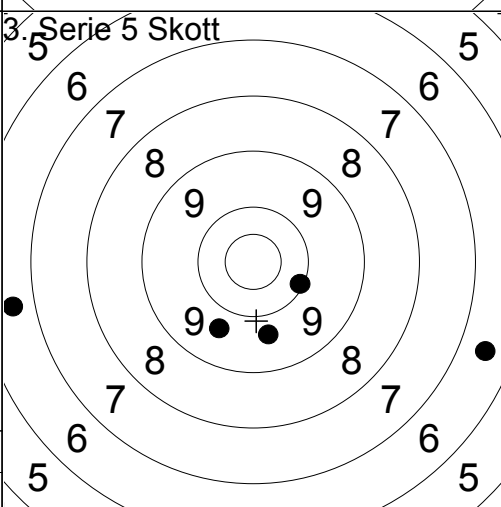

1:	9.7	↘
2:	9.7	↘
3:	10.1	↘
4:	6.6	←
5:	6.6	↘
Serie		40.0
Total		138.0

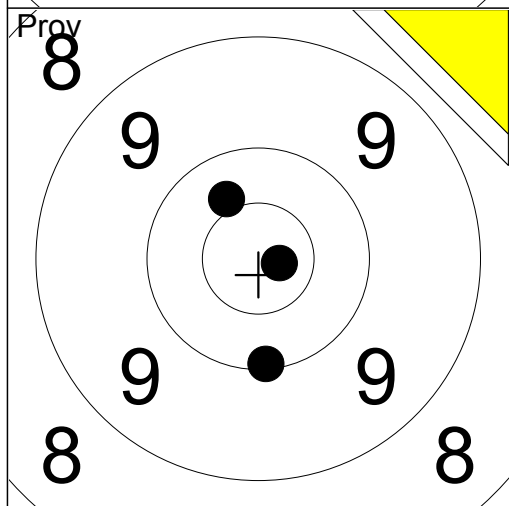

1:	10.1	↘
2:	10.4	↗
3:	*10.8	→
Serie		30.0
Total		138.0

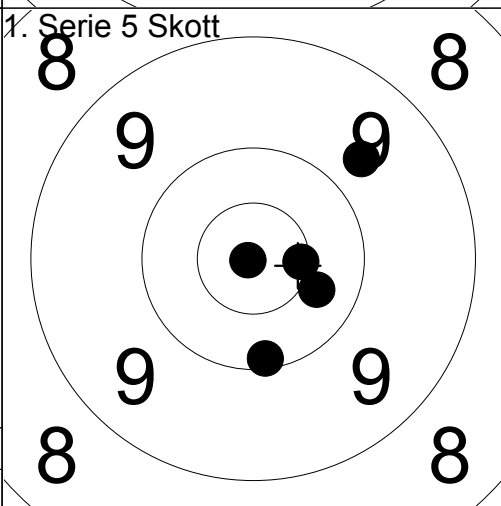

1:	10.1	↘
2:	10.4	→
3:	9.7	↗
4:	*10.9	←
5:	*10.6	→
Serie		49.0
Total		187.0

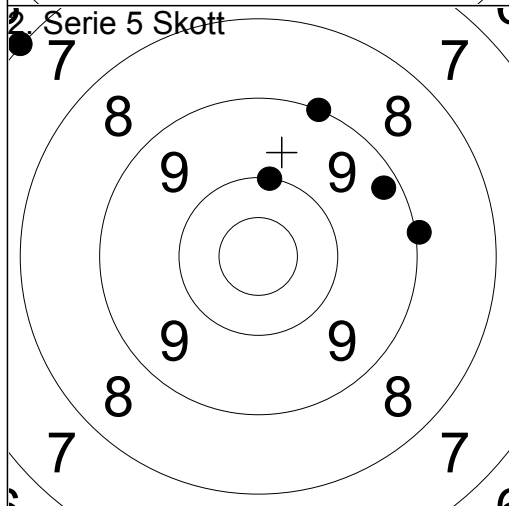

1:	9.0	→
2:	9.2	↗
3:	10.0	↑
4:	7.0	↖
5:	9.0	↗
Serie		44.0
Total		231.0

Skjutlag 1 Tavla 9 **Casper Fredriksson**

300m Ramselefors Jun Vb

15.07.2015 Björskottet 2015 Ramselefors SKF

5 Skott Prov

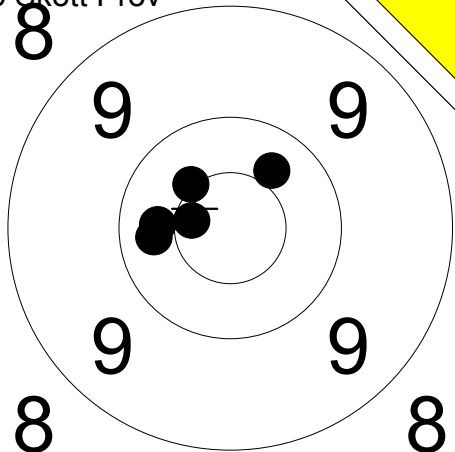

- 1: *10.6 ←
- 2: 10.3 ←
- 3: 10.3 ←
- 4: 10.4 ↗
- 5: *10.5 ↗

Serie 50.0
Total 0.0

1. Serie 5 Skott

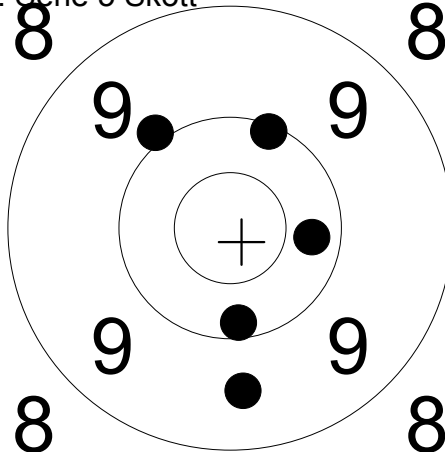

- 1: 10.1 ↗
- 2: 9.9 ↗
- 3: 10.2 ↓
- 4: 9.6 ↓
- 5: 10.3 →

Serie 48.0
Total 48.0

2. Serie 5 Skott

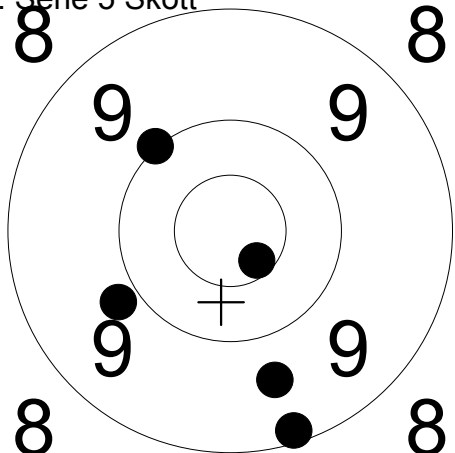

- 1: 9.8 ↙
- 2: 10.0 ↗
- 3: *10.6 ↓
- 4: 9.6 ↓
- 5: 9.1 ↓

Serie 47.0
Total 95.0

3. Serie 5 Skott

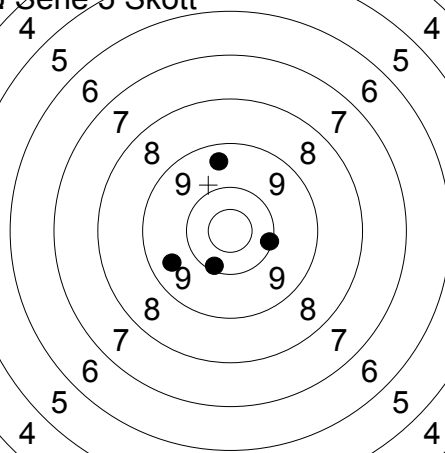

- 1: 9.4 ↑
- 2: 10.1 →
- 3: 9.5 ↙
- 4: 10.1 ↓
- 5: 5.4 ↑

Serie 43.0
Total 138.0

Prov

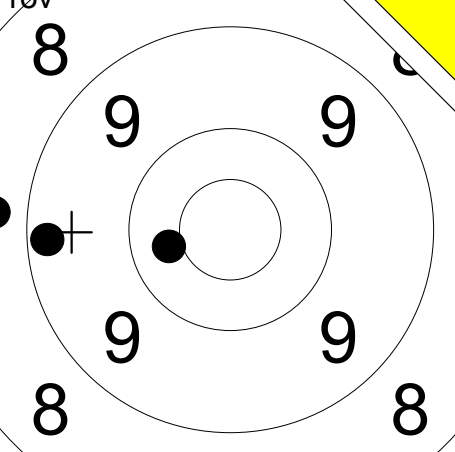

- 1: 8.7 ←
- 2: 10.4 ←
- 3: 9.2 ←

Serie 27.0
Total 138.0

1. Serie 5 Skott

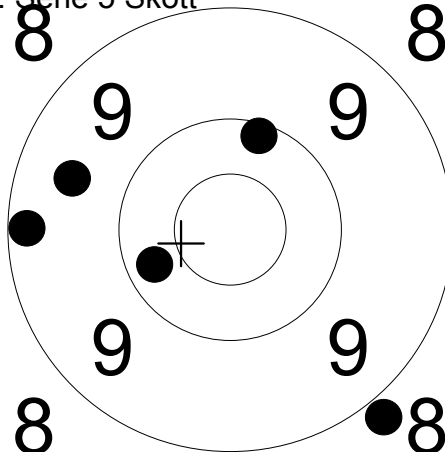

- 1: 9.5 ←
- 2: 10.1 ↑
- 3: 9.2 ←
- 4: 10.3 ↙
- 5: 8.8 ↓

Serie 46.0
Total 184.0

2. Serie 5 Skott

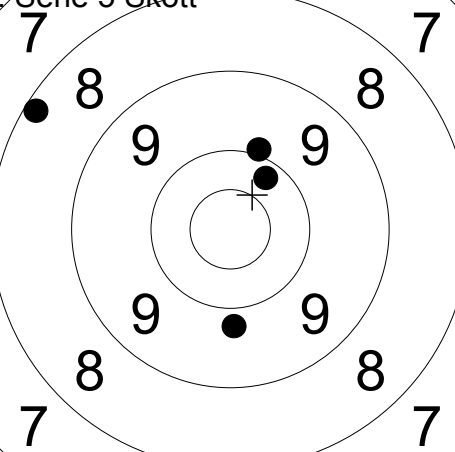

- 1: 10.2 ↗
- 2: 9.8 ↓
- 3: 10.0 ↗
- 4: 8.0 →
- 5: 8.2 ↖

Serie 45.0
Total 229.0

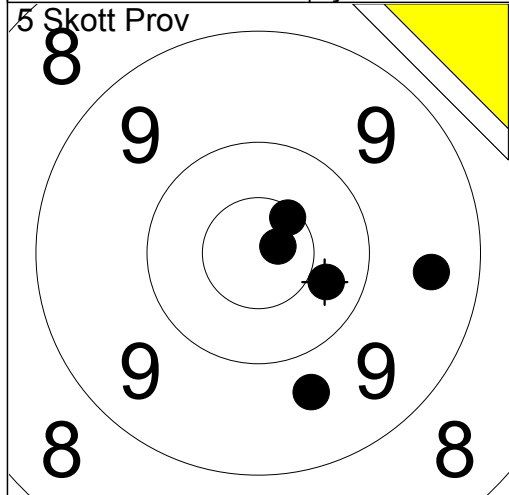

1:	9.7	↘
2:	*10.8	→
3:	10.3	↗
4:	*10.6	↗
5:	9.5	→

Serie	48.0
Total	0.0

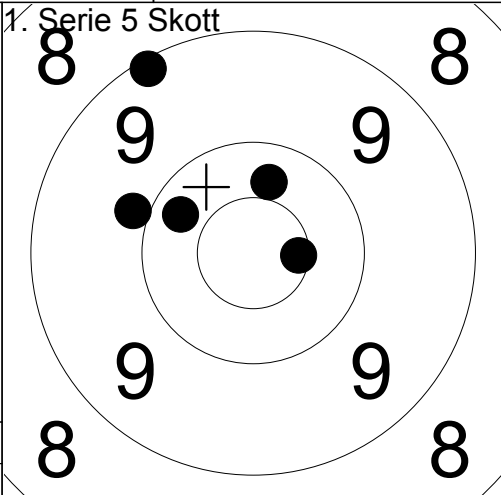

1:	9.1	↗
2:	9.9	↖
3:	10.3	↑
4:	10.3	↖
5:	*10.6	→

Serie	48.0
Total	48.0

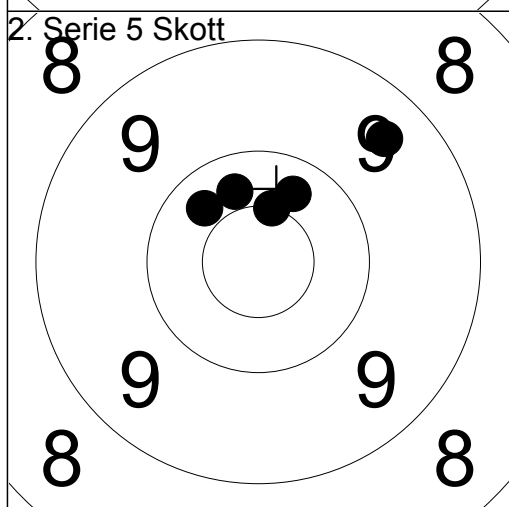

1:	*10.5	↑
2:	10.3	↑
3:	10.3	↖
4:	9.4	↗
5:	10.3	↑

Serie	49.0
Total	97.0

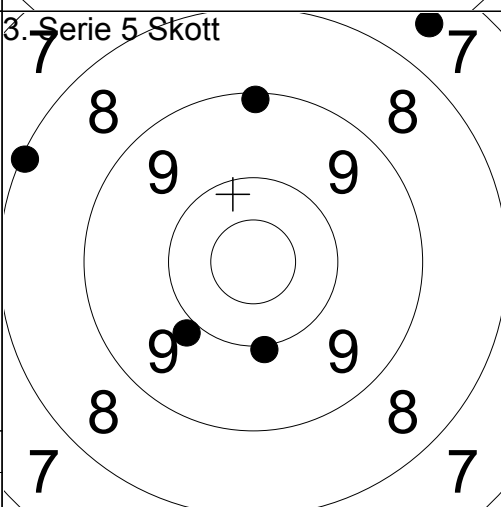

1:	9.1	↑
2:	10.0	↓
3:	9.9	↙
4:	7.5	↗
5:	8.1	↖

Serie	43.0
Total	140.0

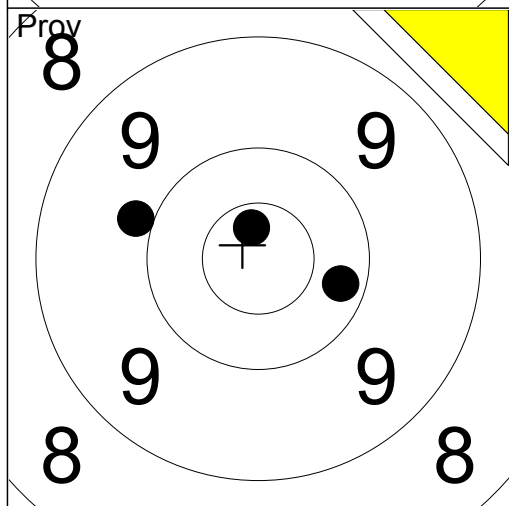

1:	9.9	↖
2:	*10.7	↑
3:	10.2	↘

Serie	29.0
Total	140.0

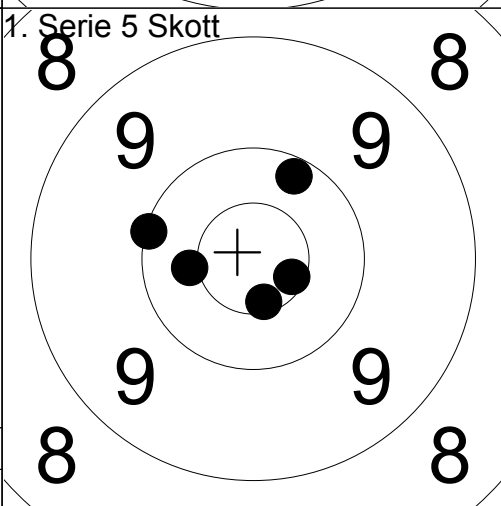

1:	10.2	↗
2:	*10.4	←
3:	10.1	←
4:	*10.6	↘
5:	*10.6	↓

Serie	50.0
Total	190.0

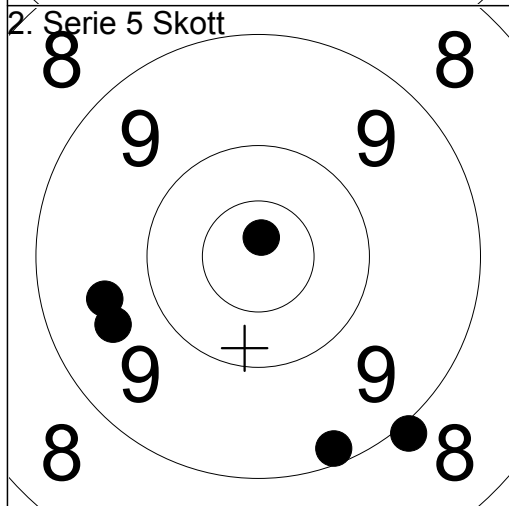

1:	9.2	↘
2:	9.6	↖
3:	*10.8	↑
4:	8.9	↘
5:	9.6	←

Serie	45.0
Total	235.0

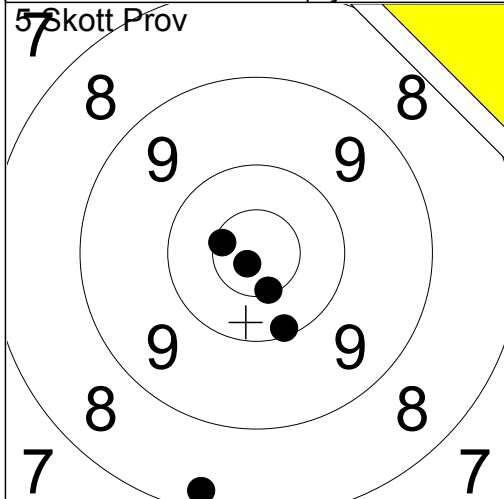

1. Serie 5 Skott

1:	*10.8	↙
2:	10.1	↓
3:	*10.5	↓
4:	*10.6	↙
5:	8.3	↓
Serie	48.0	
Total	0.0	

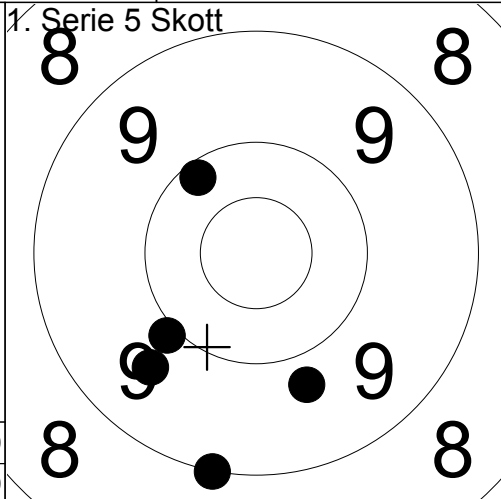

1:	10.2	↖
2:	9.8	↓
3:	9.9	↙
4:	9.0	↓
5:	9.6	↙
Serie	46.0	
Total	46.0	

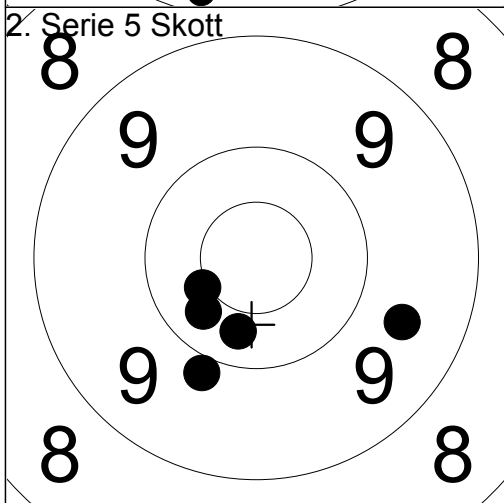

1:	10.3	↓
2:	*10.4	↙
3:	9.9	↓
4:	10.3	↙
5:	9.6	↘
Serie	48.0	
Total	94.0	

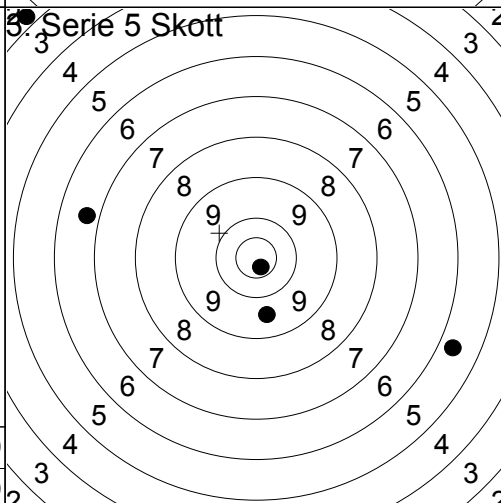

1:	6.7	↙
2:	9.6	↓
3:	*10.7	↙
4:	2.8	↗
5:	5.7	↘
Serie	32.0	
Total	126.0	

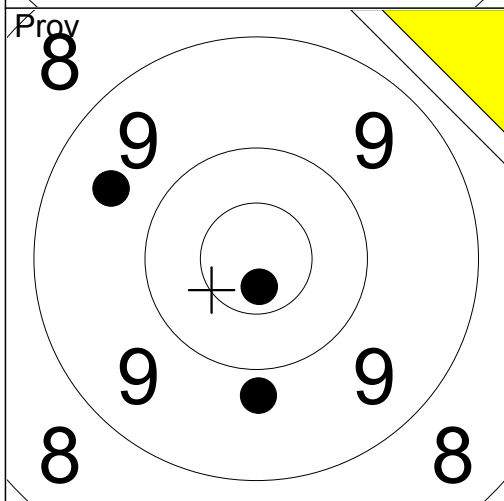

1:	9.6	↙
2:	9.8	↓
3:	*10.7	↓
Serie	28.0	
Total	126.0	

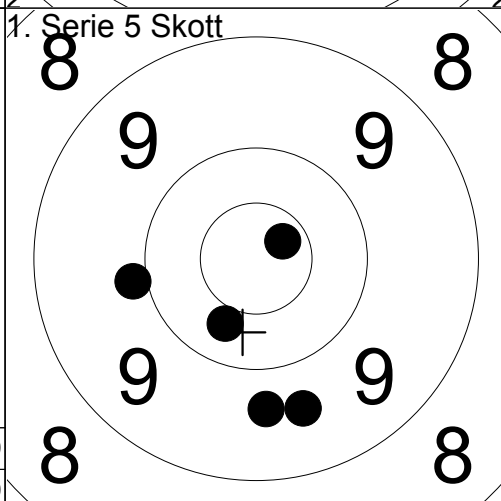

1:	9.9	↙
2:	9.7	↓
3:	10.4	↙
4:	9.6	↓
5:	*10.7	↗
Serie	47.0	
Total	173.0	

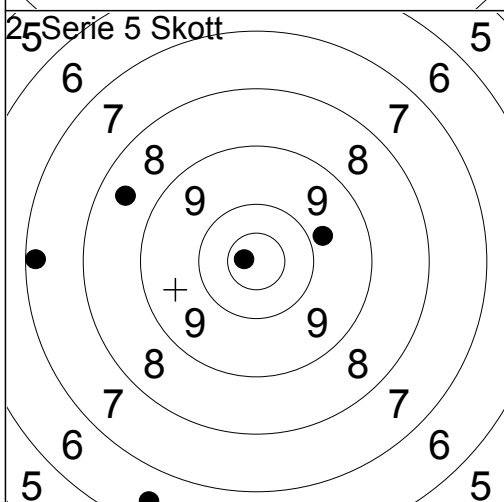

1:	*10.8	↙
2:	9.8	↘
3:	8.5	↙
4:	6.5	↓
5:	7.2	↙
Serie	40.0	
Total	213.0	

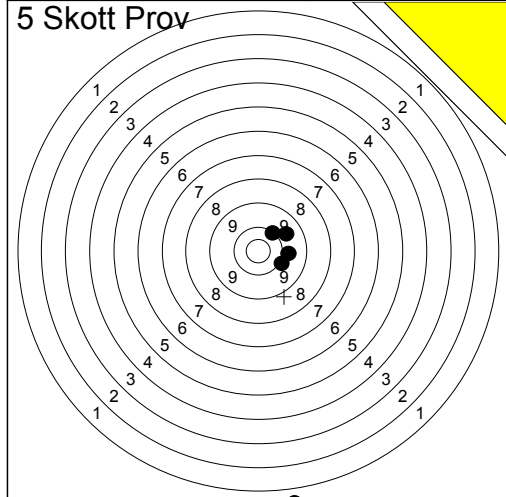

1:	0.0	↓
2:	10.0	↘
3:	10.1	↗
4:	9.8	→
5:	9.7	↗
Serie		38.0
Total		0.0

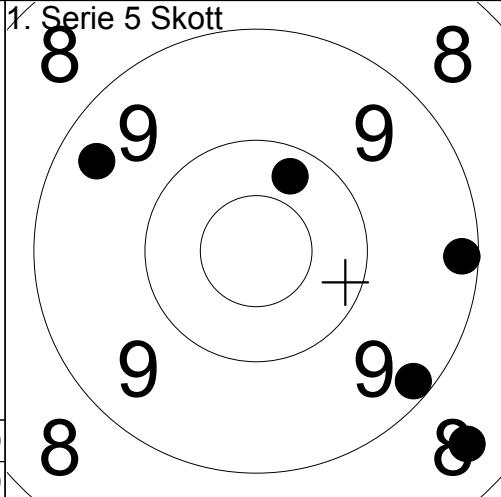

1:	9.4	↗
2:	9.2	→
3:	8.5	↘
4:	9.2	↘
5:	10.3	↗
Serie		45.0
Total		45.0

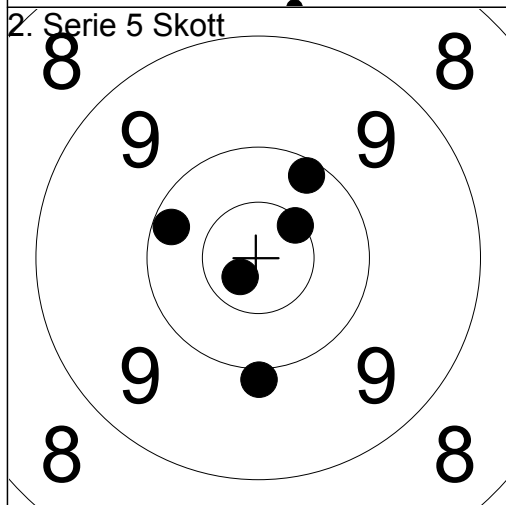

1:	10.2	↗
2:	*10.7	↘
3:	10.2	←
4:	*10.5	↗
5:	9.9	↓
Serie		49.0
Total		94.0

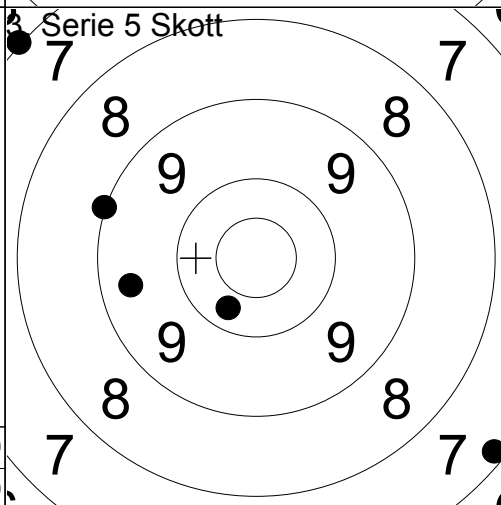

1:	10.3	↘
2:	9.0	←
3:	9.4	←
4:	7.2	↘
5:	7.0	↗
Serie		42.0
Total		136.0

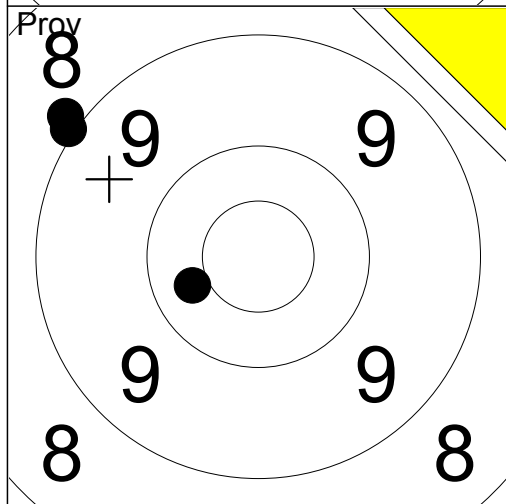

1:	10.4	←
2:	8.9	↗
3:	9.0	↗
Serie		27.0
Total		136.0

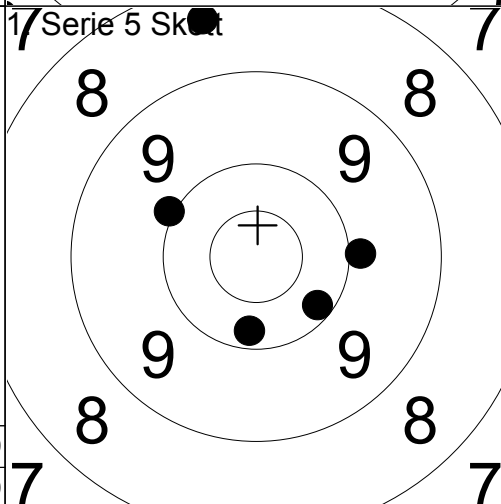

1:	8.4	↗
2:	10.2	↘
3:	10.2	↘
4:	9.9	→
5:	10.0	↗
Serie		47.0
Total		183.0

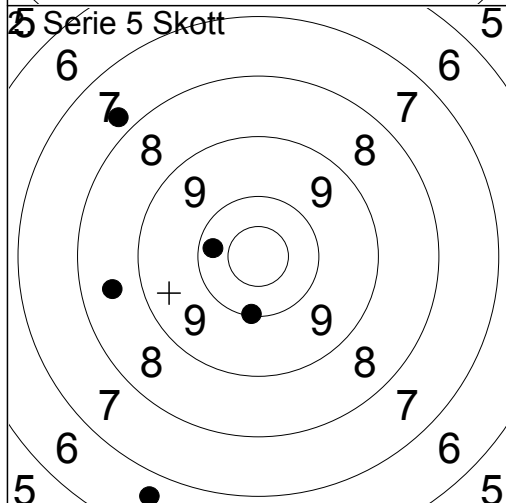

1:	10.1	↓
2:	8.5	←
3:	10.2	←
4:	7.8	↗
5:	6.7	↘
Serie		41.0
Total		224.0

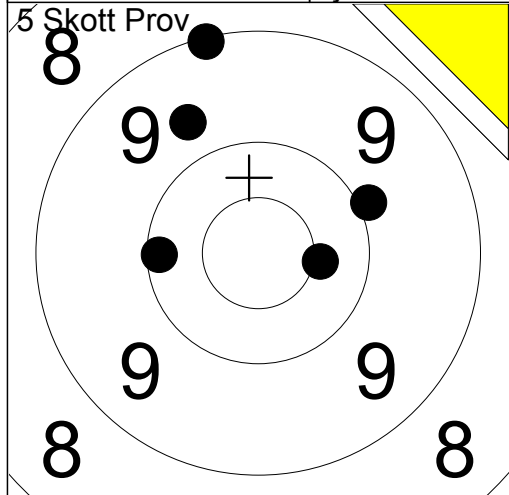

1:	9.7	↗
2:	9.1	↑
3:	*10.4	→
4:	10.1	←
5:	9.9	↘

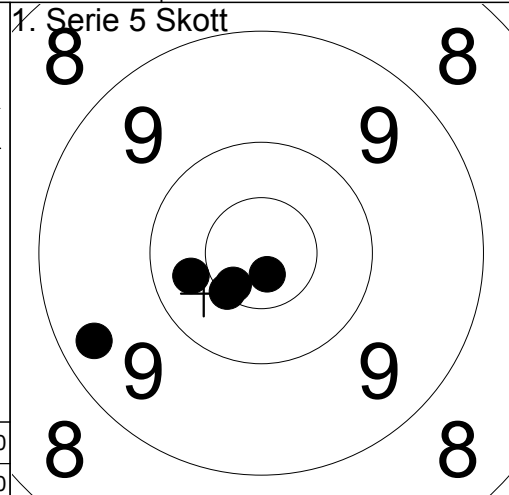

1:	*10.5	↙
2:	*10.6	↙
3:	10.3	←
4:	*10.8	↘
5:	9.3	↙

Serie	47.0
Total	0.0

Serie	49.0
Total	49.0

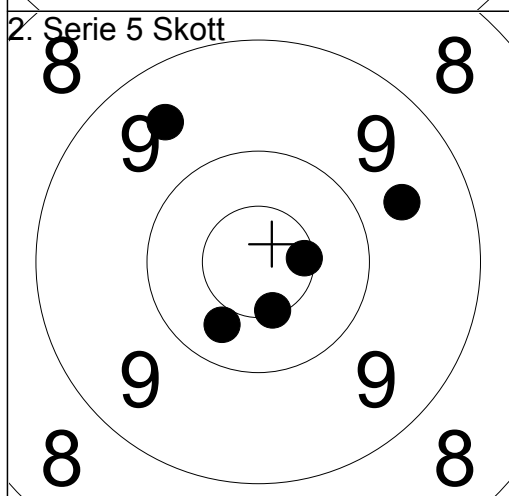

1:	9.6	↘
2:	*10.6	→
3:	10.3	↙
4:	9.5	↗
5:	*10.5	↘

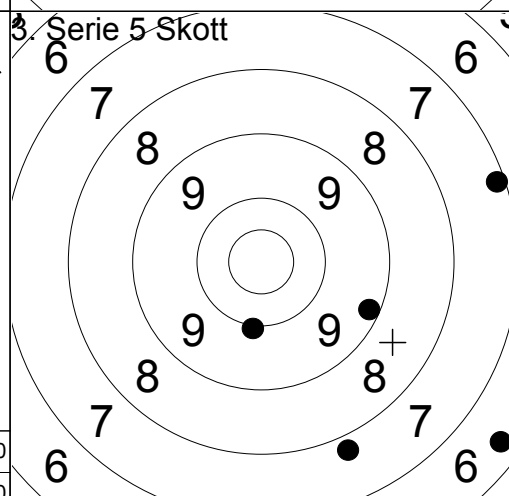

1:	7.8	↘
2:	9.2	↘
3:	10.0	↘
4:	6.4	↘
5:	7.2	→

Serie	48.0
Total	97.0

Serie	39.0
Total	136.0

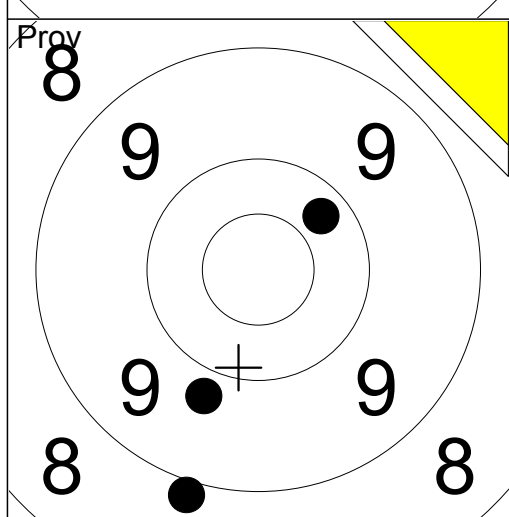

1:	9.8	↘
2:	10.3	↗
3:	8.9	↘

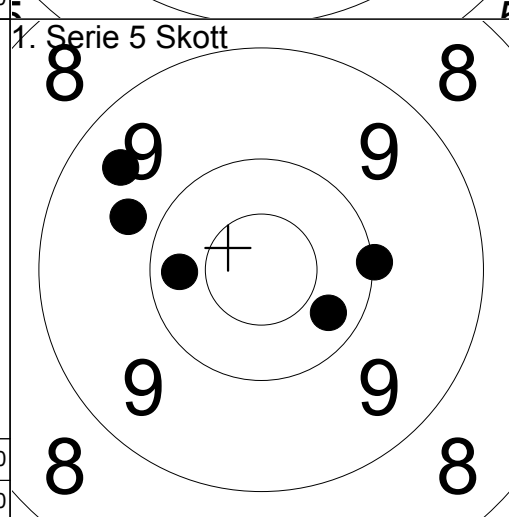

1:	10.3	←
2:	10.3	↘
3:	9.5	↗
4:	9.7	↗
5:	10.0	→

Serie	27.0
Total	136.0

Serie	48.0
Total	184.0

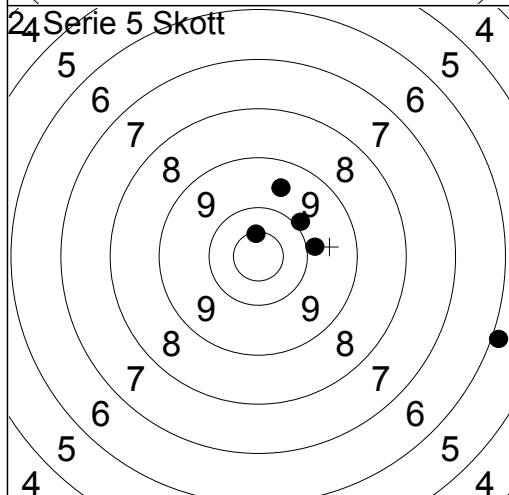

1:	9.9	→
2:	*10.5	↑
3:	9.6	↗
4:	9.9	↗
5:	5.9	↘

Serie	42.0
Total	226.0

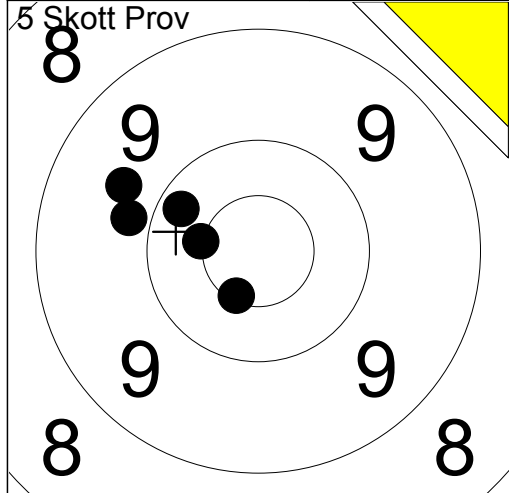

1:	9.8	←
2:	*10.5	↓
3:	10.2	↗
4:	9.7	↖
5:	*10.5	←

Serie	48.0
Total	0.0

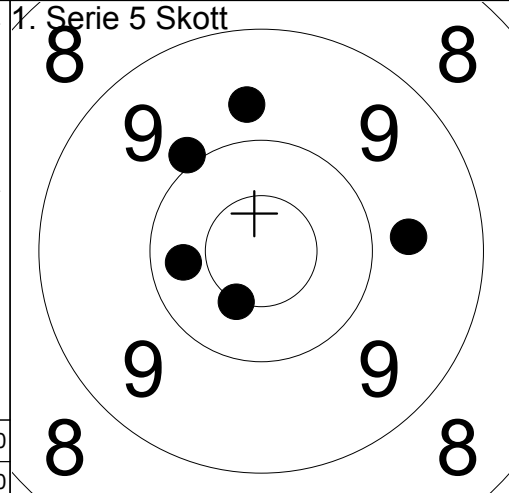

1:	9.7	→
2:	9.9	↖
3:	10.3	←
4:	*10.5	↓
5:	9.7	↑

Serie	47.0
Total	47.0

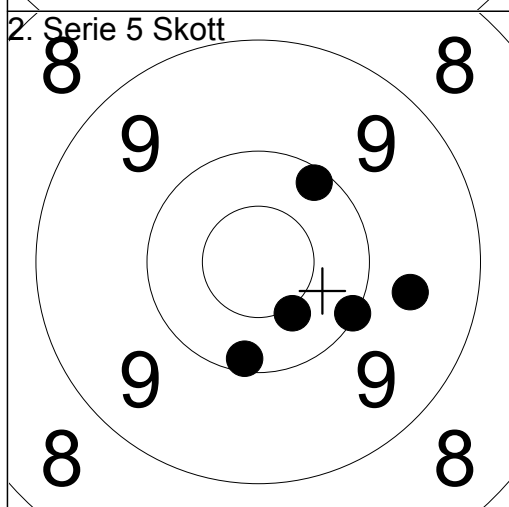

1:	9.6	→
2:	*10.4	↓
3:	10.1	↓
4:	10.1	↘
5:	10.1	↗

Serie	49.0
Total	96.0

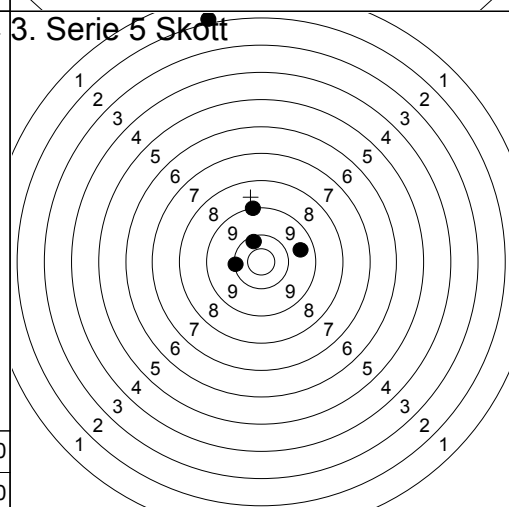

1:	10.1	←
2:	9.5	→
3:	10.2	↖
4:	9.0	↑
5:	1.9	↑

Serie	39.0
Total	135.0

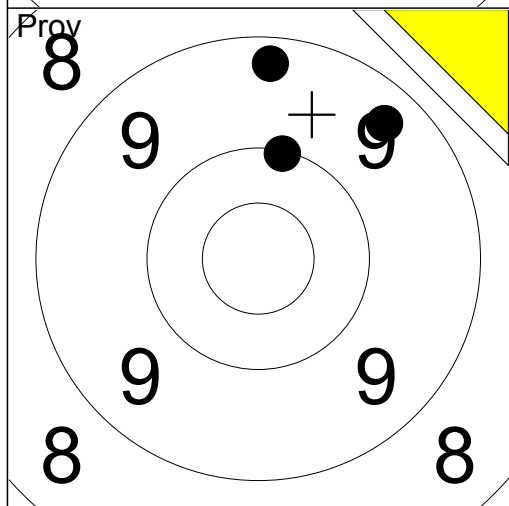

1:	9.3	↑
2:	10.0	↑
3:	9.4	↗

Serie	28.0
Total	135.0

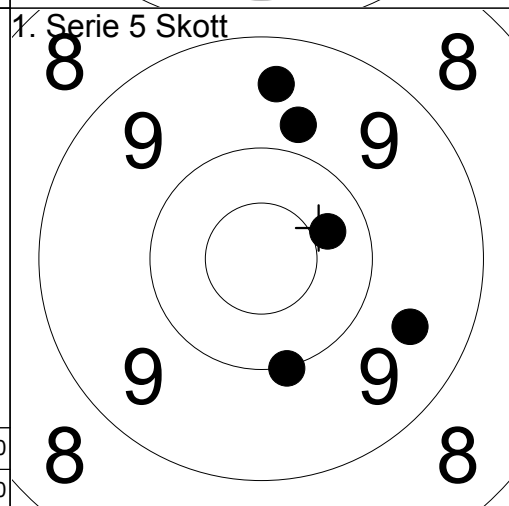

1:	9.6	↘
2:	10.0	↓
3:	10.4	→
4:	9.5	↑
5:	9.8	↑

Serie	47.0
Total	182.0

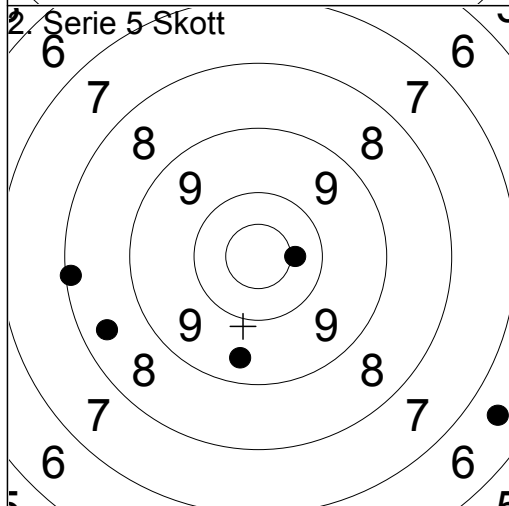

1:	8.1	←
2:	*10.4	→
3:	9.4	↓
4:	8.4	←
5:	6.6	↘

Serie	41.0
Total	223.0

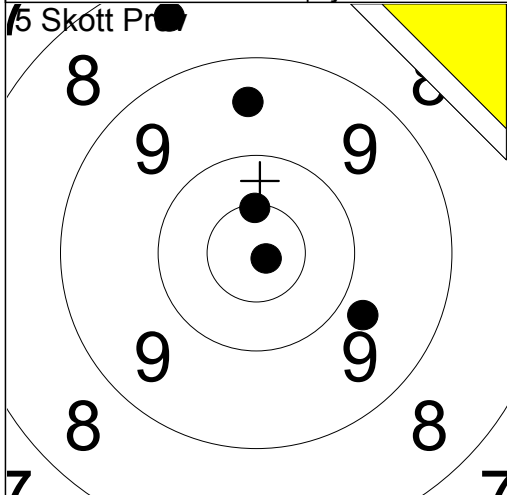

1:	9.5	↑
2:	8.5	↑
3:	*10.8	↘
4:	9.8	↘
5:	*10.5	↑

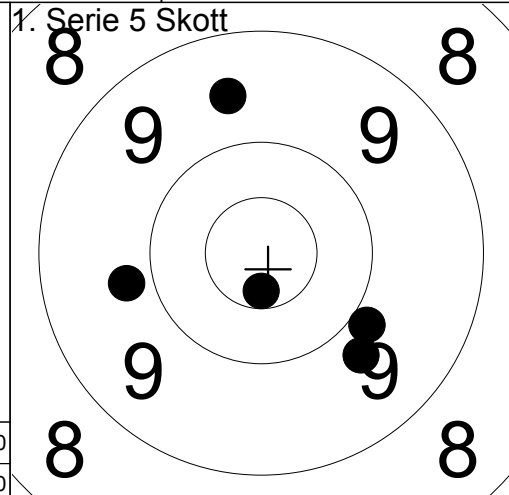

1:	9.9	↘
2:	9.8	←
3:	*10.6	↓
4:	9.6	↑
5:	9.7	↘

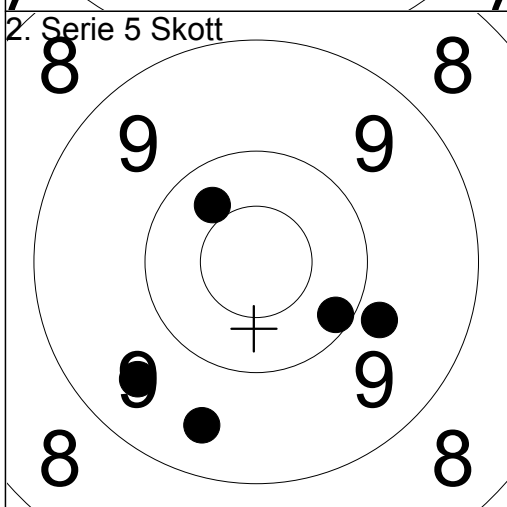

1:	9.5	↙
2:	10.2	↘
3:	9.8	↘
4:	9.5	↘
5:	10.4	↗

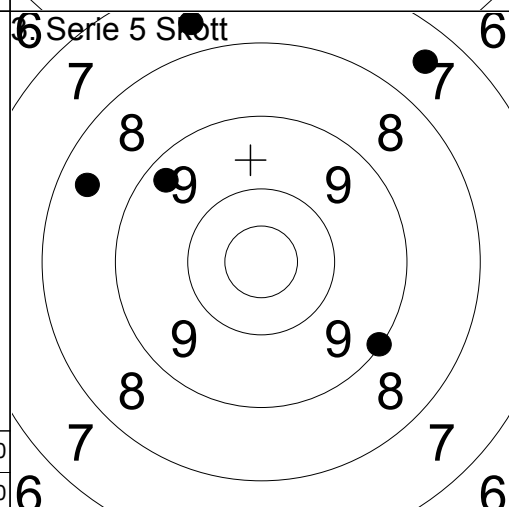

1:	9.1	↘
2:	8.4	↗
3:	9.3	↗
4:	7.5	↗
5:	7.6	↑

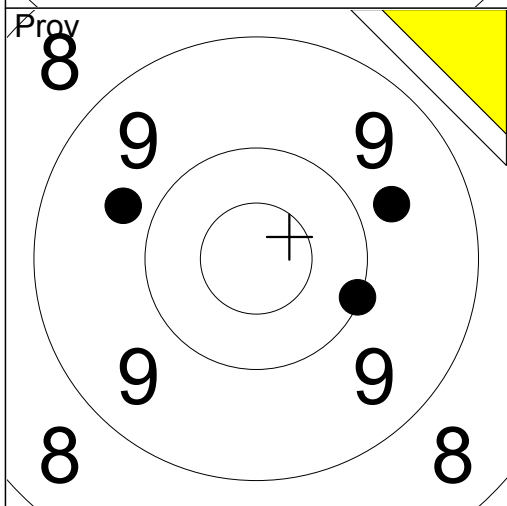

1:	9.7	→
2:	10.0	→
3:	9.7	↑

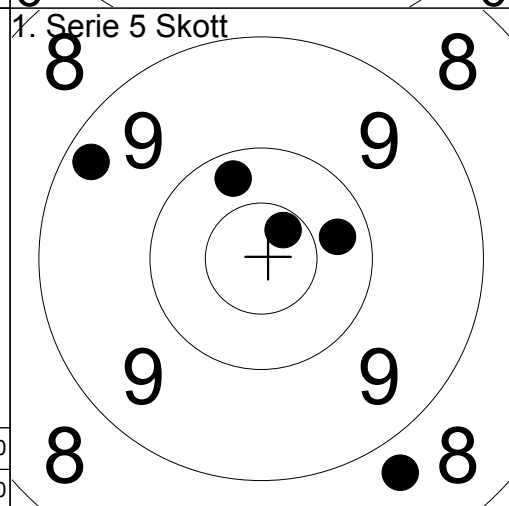

1:	9.3	↙
2:	10.3	→
3:	10.2	↑
4:	*10.6	↗
5:	8.7	↘

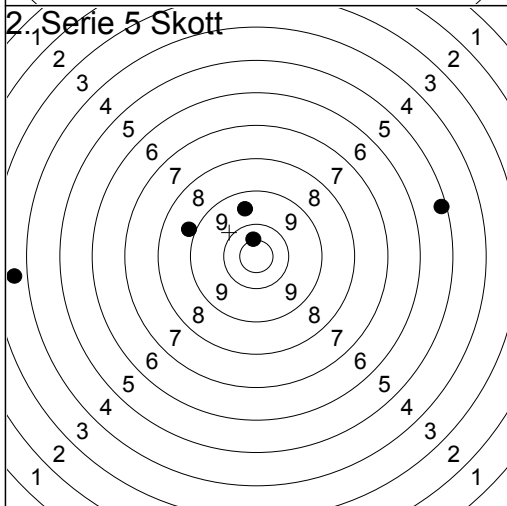

1:	*10.4	↑
2:	9.5	↑
3:	8.8	↙
4:	5.2	→
5:	3.6	←

Serie	46.0
Total	0.0
Serie	47.0
Total	93.0
Serie	28.0
Total	133.0
Serie	35.0
Total	215.0

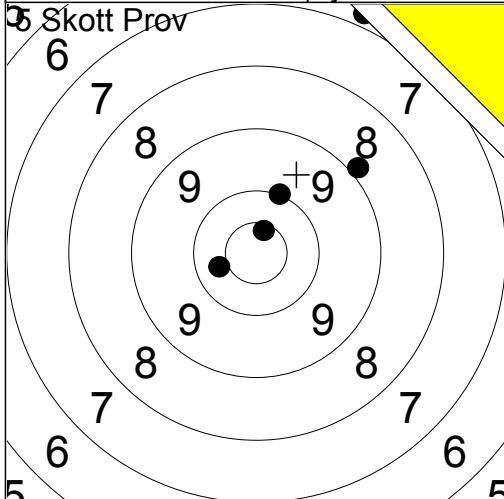

1:	6.8	↗
2:	8.9	↗
3:	10.0	↗
4:	*10.6	↗
5:	10.4	←

Serie	44.0
Total	0.0

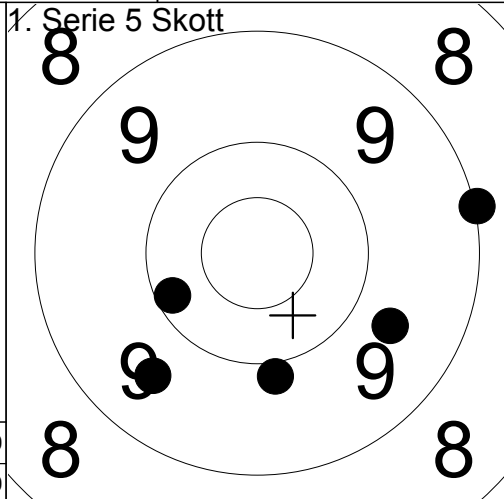

1:	9.0	→
2:	9.7	↘
3:	10.2	↙
4:	9.9	↓
5:	9.6	↙

Serie	46.0
Total	46.0

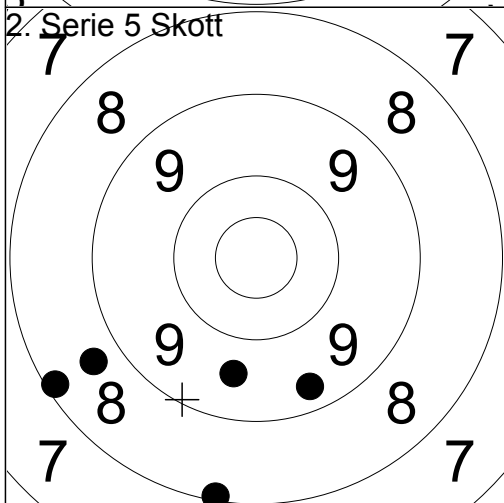

1:	8.1	↙
2:	9.3	↓
3:	9.6	↓
4:	8.7	↙
5:	8.1	↓

Serie	42.0
Total	88.0

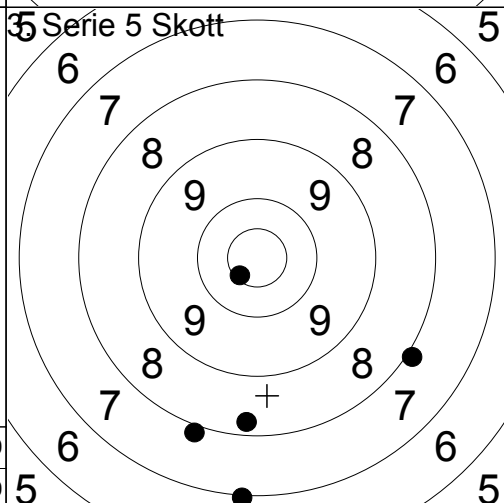

1:	8.3	↓
2:	7.0	↓
3:	7.9	↘
4:	7.9	↓
5:	*10.6	↙

Serie	39.0
Total	127.0

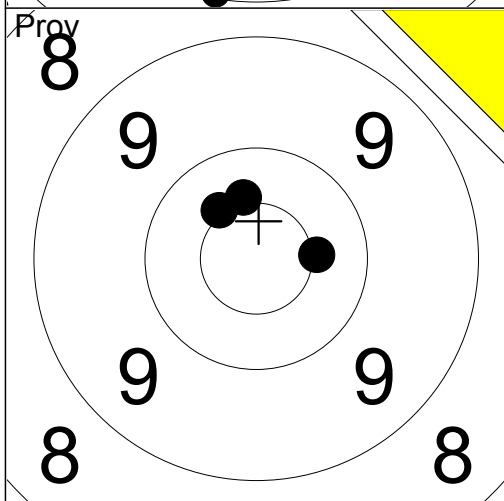

1:	*10.4	→
2:	*10.4	↗
3:	*10.4	↗

Serie	30.0
Total	127.0

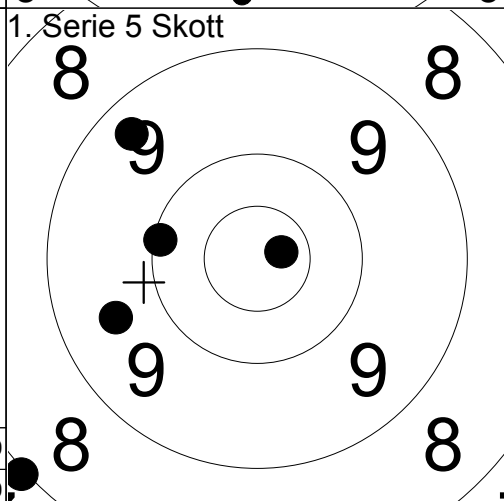

1:	9.3	↗
2:	10.1	←
3:	8.0	↙
4:	9.6	↙
5:	*10.7	→

Serie	46.0
Total	173.0

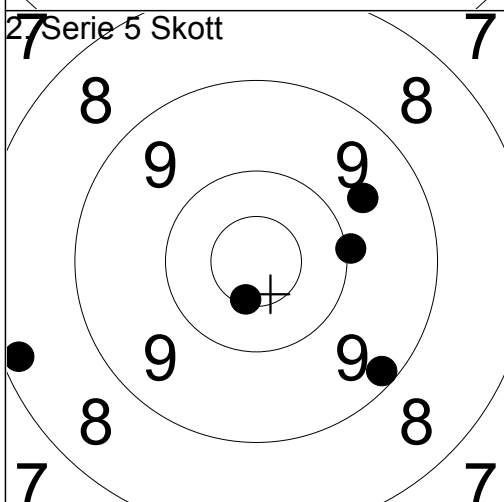

1:	9.7	↗
2:	8.2	↙
3:	9.2	↘
4:	*10.5	↓
5:	10.0	→

Serie	46.0
Total	219.0

Skjutlag 1 Tavla 18 Torvald Andersson

300m Bälunge-Jumkil Vet Up

15.07.2015 Björkskottet 2015 Ramselefors SKF

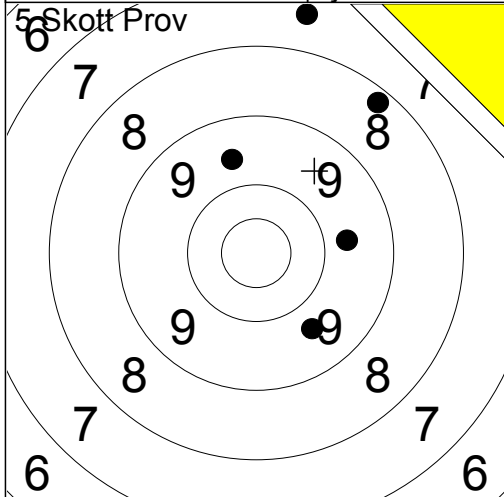

1:	8.2	↗
2:	9.7	↘
3:	9.6	↑
4:	7.5	↑
5:	9.7	→
Serie	42.0	
Total	0.0	

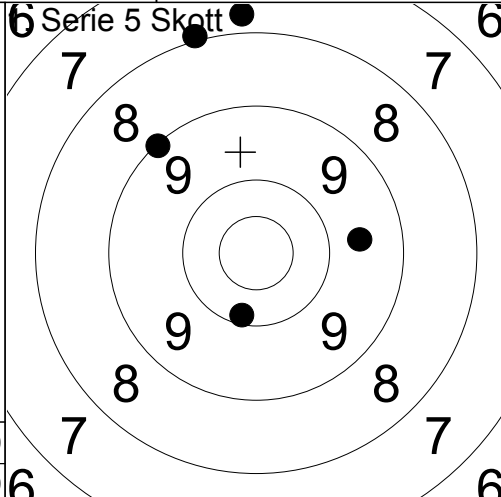

1:	7.8	↑
2:	8.0	↑
3:	10.2	↘
4:	9.6	→
5:	9.1	↗
Serie	43.0	
Total	43.0	

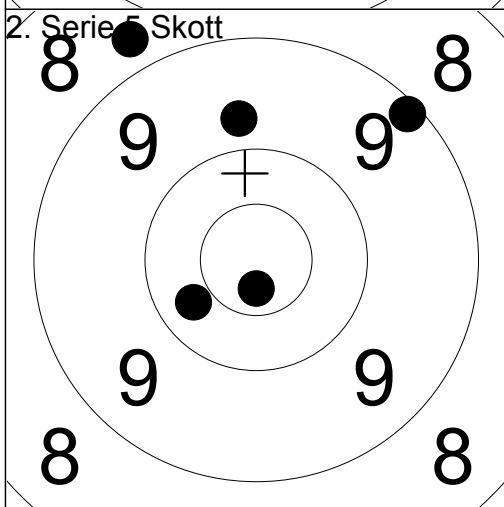

1:	9.7	↑
2:	10.3	↙
3:	*10.7	↘
4:	8.7	↗
5:	9.1	↗
Serie	46.0	
Total	89.0	

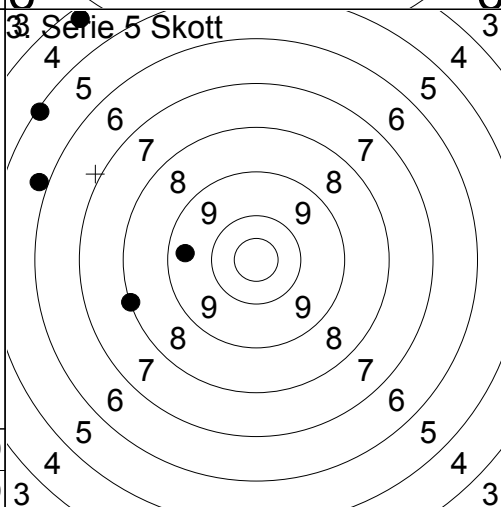

1:	5.8	↙
2:	4.3	↗
3:	8.0	↙
4:	9.4	↙
5:	5.1	↗
Serie	31.0	
Total	120.0	

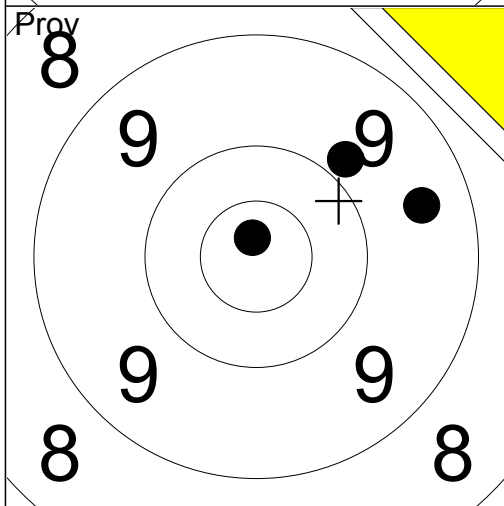

1:	9.5	→
2:	*10.8	↑
3:	9.8	↗
Serie	28.0	
Total	120.0	

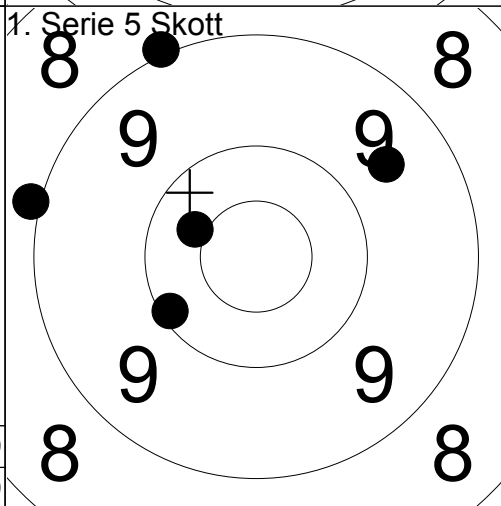

1:	9.6	↗
2:	10.1	↙
3:	8.9	↙
4:	9.0	↗
5:	10.4	↗
Serie	46.0	
Total	166.0	

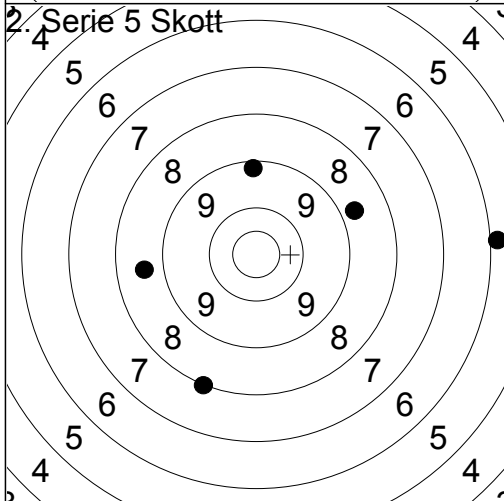

1:	8.6	↙
2:	5.9	→
3:	9.2	↑
4:	8.0	↘
5:	8.7	↗
Serie	38.0	
Total	204.0	

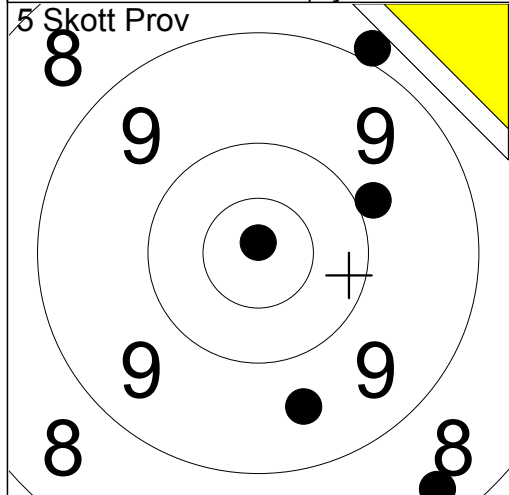

1:	9.9	➔
2:	*10.9	↑
3:	9.6	↓
4:	8.9	↗
5:	8.3	↓
Serie		44.0
Total		0.0

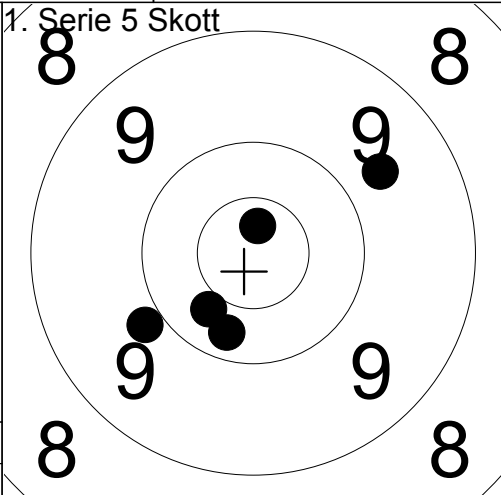

1:	9.7	➔
2:	10.4	↘
3:	*10.7	↑
4:	10.2	↓
5:	9.9	↘
Serie		48.0
Total		48.0

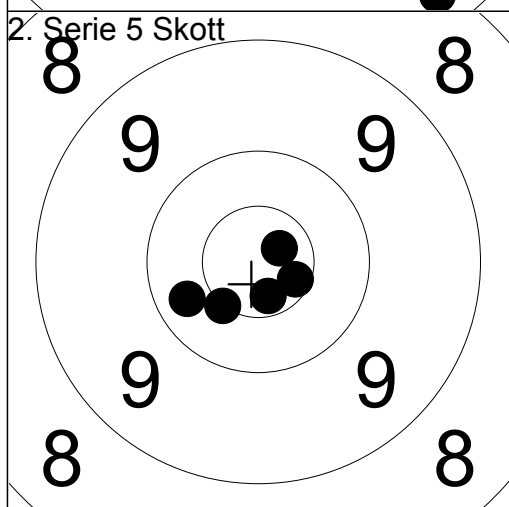

1:	*10.7	➔
2:	*10.6	➔
3:	*10.5	↘
4:	10.3	↙
5:	*10.7	↓
Serie		50.0
Total		98.0

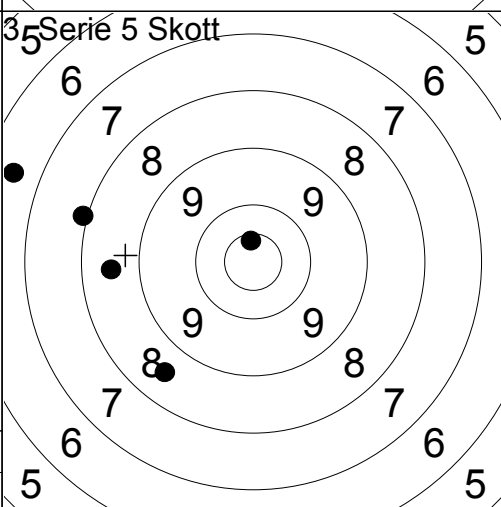

1:	*10.6	↑
2:	8.5	↙
3:	8.0	↙
4:	6.5	↙
5:	8.6	↘
Serie		40.0
Total		138.0

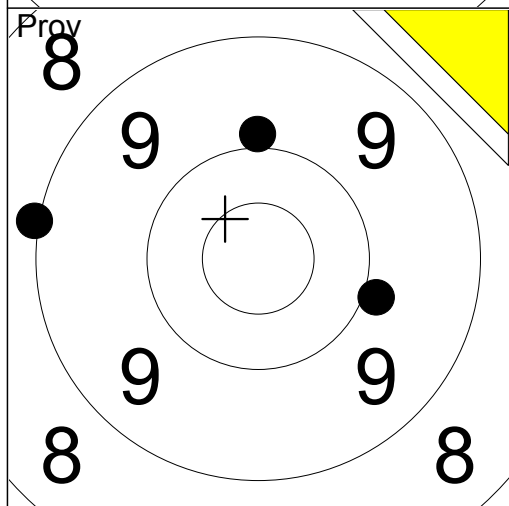

1:	9.9	↑
2:	9.0	↙
3:	9.9	➔
Serie		27.0
Total		138.0

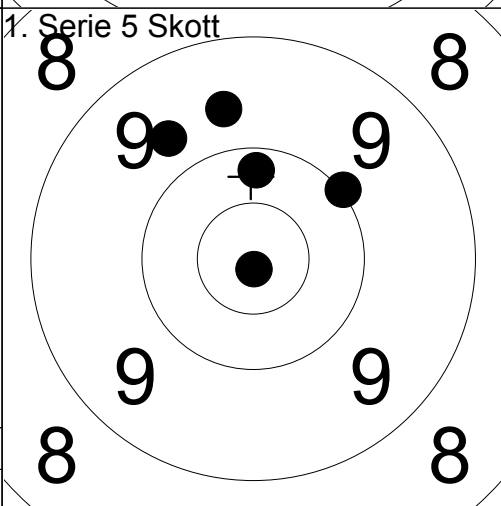

1:	10.0	➔
2:	*10.9	↓
3:	10.2	↑
4:	9.7	↗
5:	9.7	↑
Serie		48.0
Total		186.0

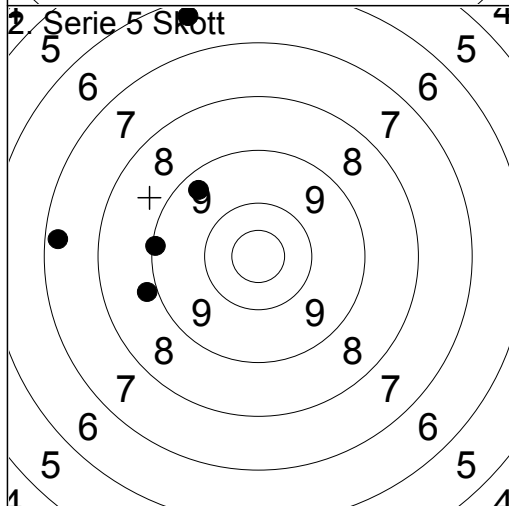

1:	8.8	↙
2:	7.3	↙
3:	9.4	↗
4:	9.1	↙
5:	6.3	↑
Serie		39.0
Total		225.0

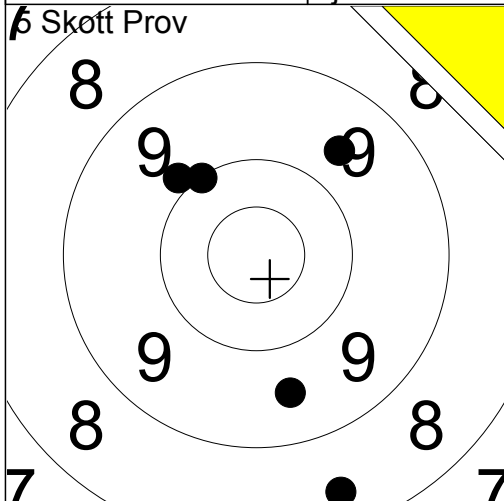

1:	8.4	↓
2:	9.6	↗
3:	9.9	↗
4:	9.6	↓
5:	10.0	↗
Serie	45.0	
Total	0.0	

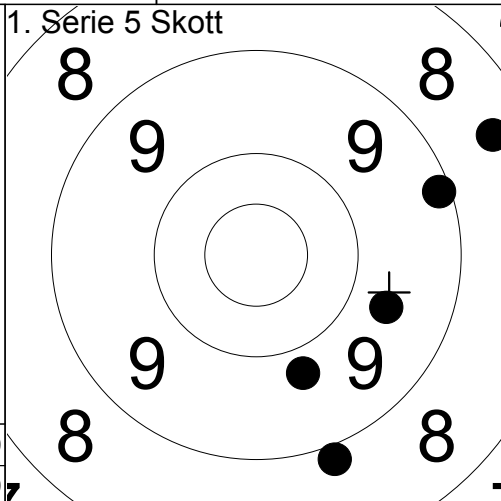

1:	8.9	↓
2:	9.7	↘
3:	8.4	↗
4:	9.1	→
5:	9.8	↓
Serie	43.0	
Total	43.0	

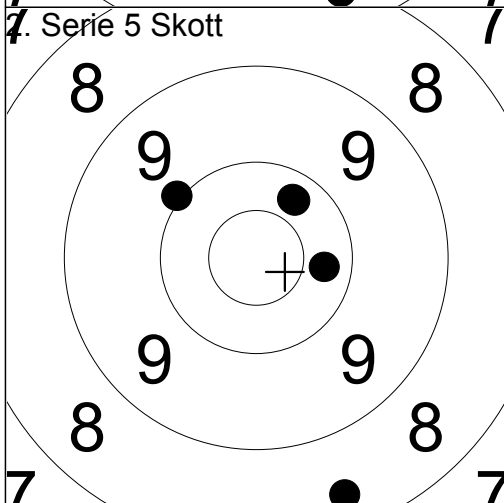

1:	8.4	↓
2:	10.0	↗
3:	10.3	→
4:	10.3	↗
5:	10.3	↗
Serie	48.0	
Total	91.0	

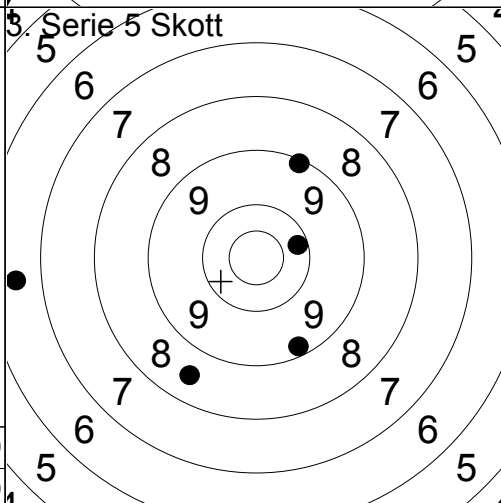

1:	9.2	↓
2:	8.5	↓
3:	10.2	→
4:	9.1	↗
5:	6.6	←
Serie	42.0	
Total	133.0	

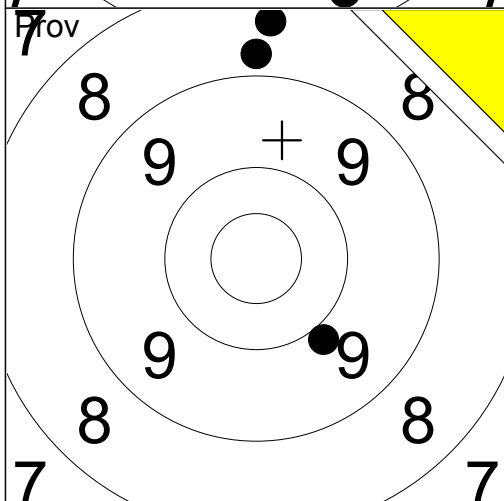

1:	8.4	↑
2:	9.9	↓
3:	8.8	↑
Serie	25.0	
Total	133.0	

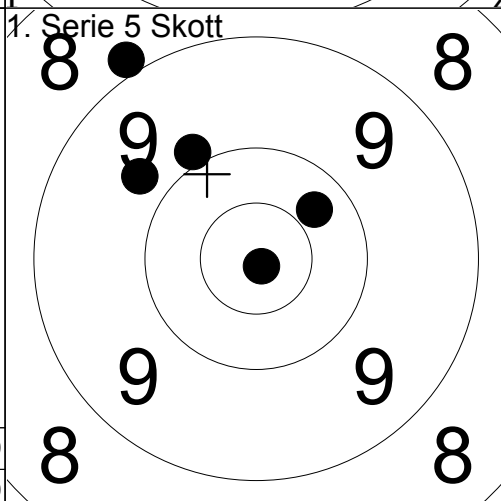

1:	10.3	↗
2:	*10.9	↓
3:	9.7	↗
4:	8.9	↗
5:	9.9	↗
Serie	46.0	
Total	179.0	

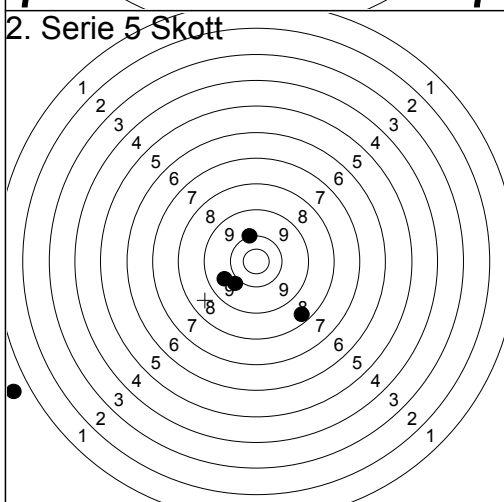

1:	9.8	↘
2:	9.6	↘
3:	8.3	↓
4:	0.0	↘
5:	10.0	↑
Serie	36.0	
Total	215.0	

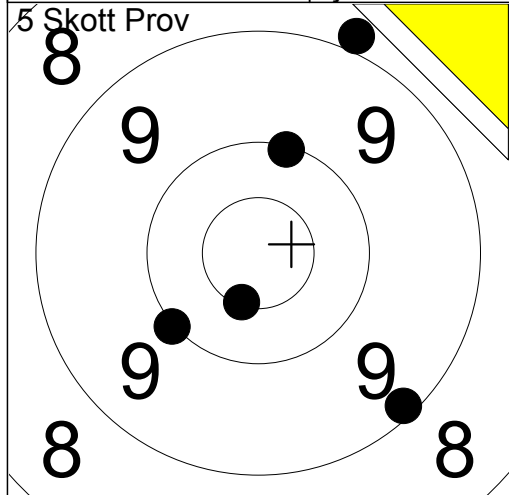

1:	10.1	↗
2:	*10.5	↘
3:	9.1	↘
4:	10.0	↙
5:	8.9	↗
Serie	47.0	
Total	0.0	

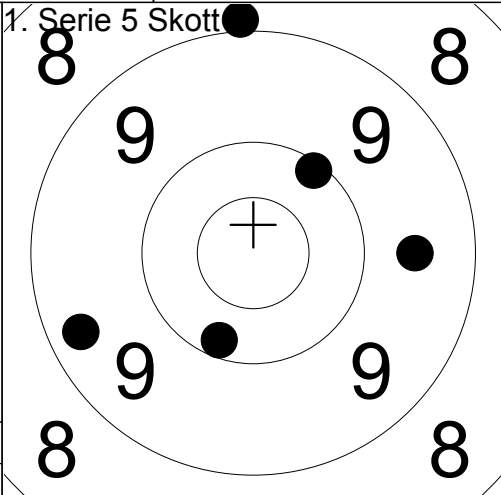

1:	8.9	↗
2:	10.1	↗
3:	9.6	→
4:	9.3	↙
5:	10.2	↘
Serie	46.0	
Total	46.0	

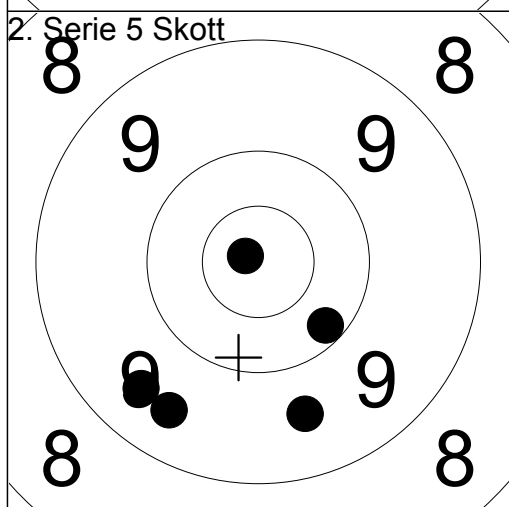

1:	*10.8	↖
2:	9.5	↘
3:	10.2	↘
4:	9.6	↘
5:	9.5	↘
Serie	47.0	
Total	93.0	

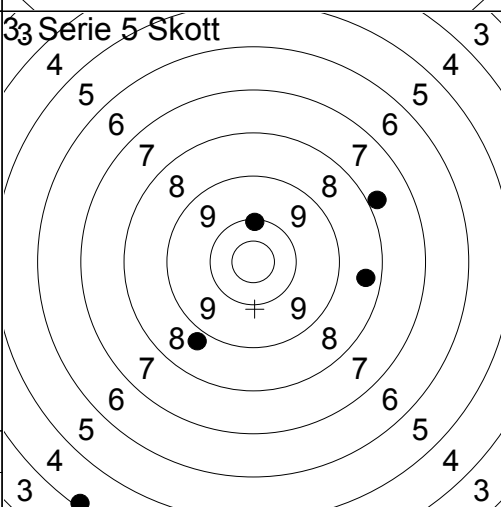

1:	8.8	↘
2:	10.1	↗
3:	4.1	↘
4:	7.8	→
5:	8.4	→
Serie	37.0	
Total	130.0	

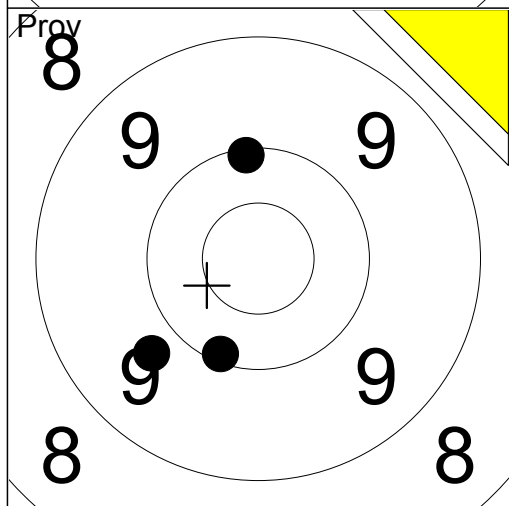

1:	10.1	↗
2:	10.1	↘
3:	9.7	↙
Serie	29.0	
Total	130.0	

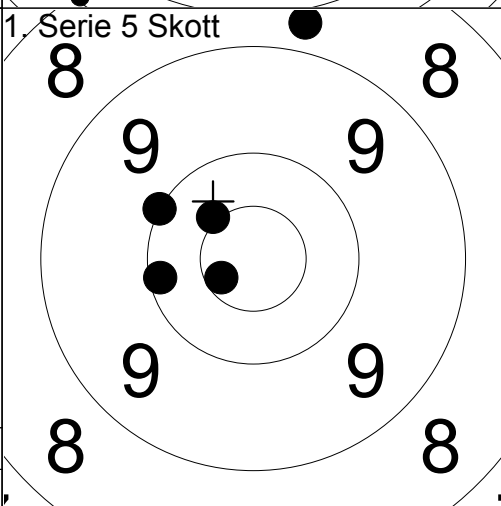

1:	*10.4	↖
2:	10.0	↖
3:	*10.6	↙
4:	10.1	←
5:	8.8	↗
Serie	48.0	
Total	178.0	

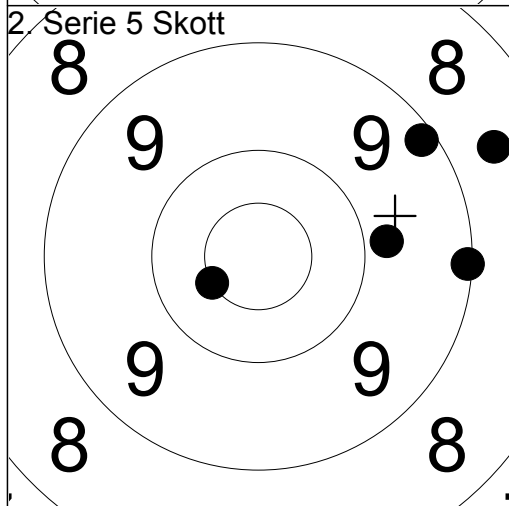

1:	9.2	↗
2:	9.8	→
3:	*10.5	↙
4:	9.1	→
5:	8.6	→
Serie	45.0	
Total	223.0	

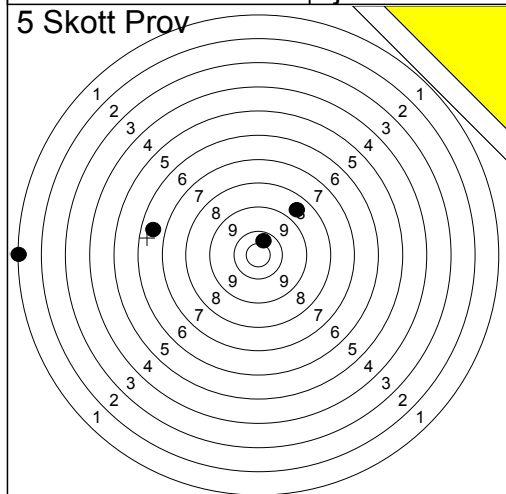

1:	1.1	←
2:	0.0	←
3:	6.5	←
4:	10.4	↗
5:	8.5	↗
Serie	25.0	
Total	0.0	

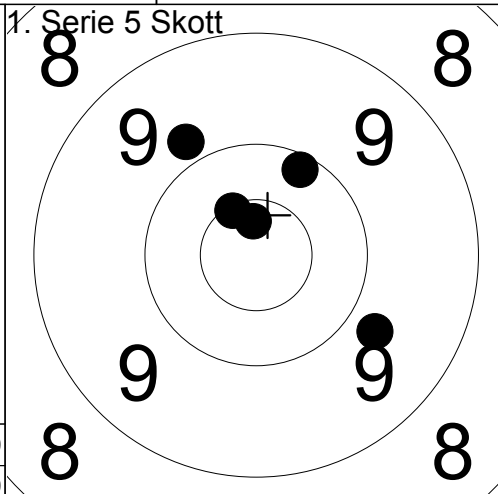

1:	10.2	↗
2:	*10.7	↑
3:	9.8	↗
4:	*10.5	↗
5:	9.8	↘
Serie	48.0	
Total	48.0	

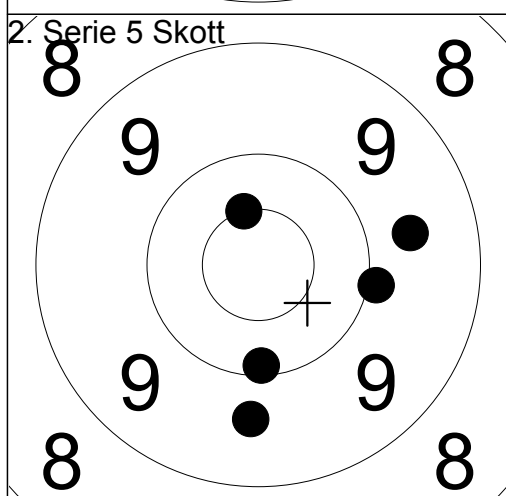

1:	9.6	↓
2:	*10.5	↑
3:	9.6	→
4:	10.1	↓
5:	10.0	→
Serie	48.0	
Total	96.0	

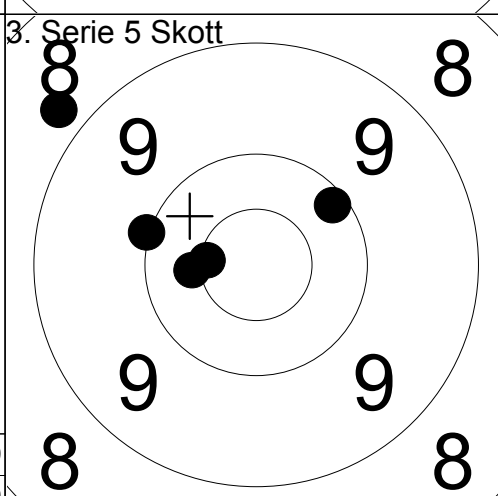

1:	10.0	←
2:	*10.4	←
3:	*10.5	←
4:	8.8	↗
5:	10.1	↗
Serie	48.0	
Total	144.0	

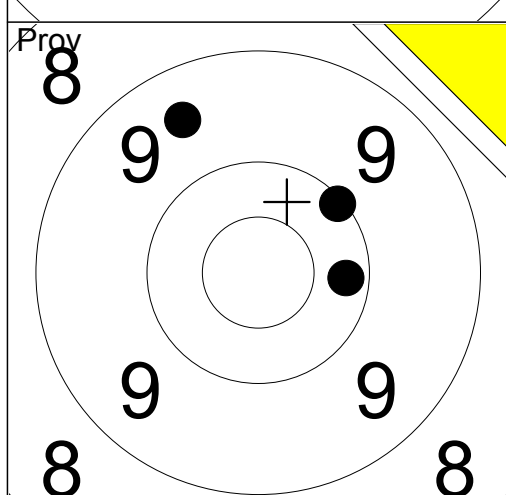

1:	9.5	↗
2:	10.1	↗
3:	10.2	→
Serie	29.0	
Total	144.0	

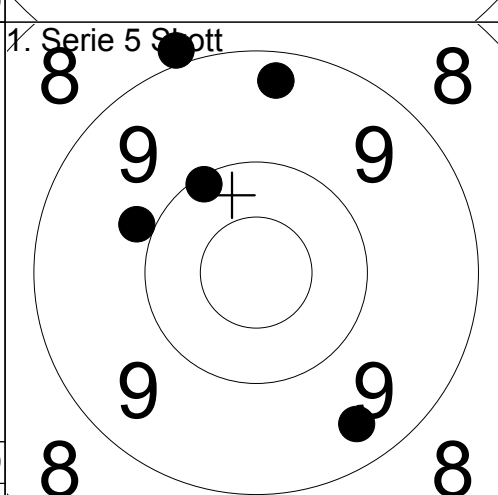

1:	8.9	↗
2:	9.3	↑
3:	9.9	↗
4:	9.4	↘
5:	10.1	↗
Serie	45.0	
Total	189.0	

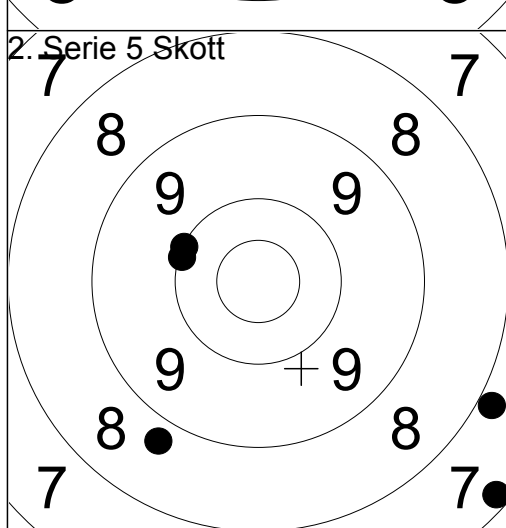

1:	10.1	↗
2:	8.8	↘
3:	7.9	↘
4:	7.2	↘
5:	10.0	↗
Serie	42.0	
Total	231.0	

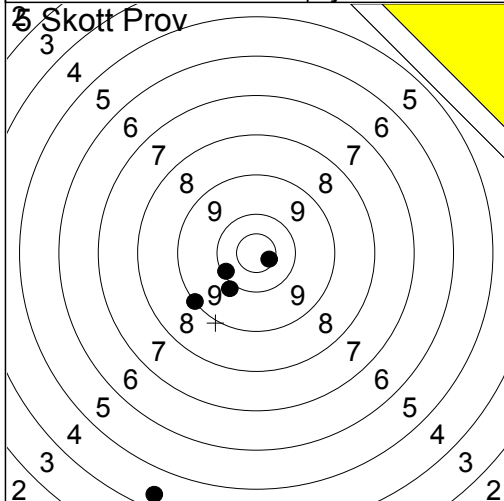

1:	4.4	↘
2:	9.1	↙
3:	10.1	↙
4:	9.9	↘
5:	*10.6	↘
Serie		42.0
Total		0.0

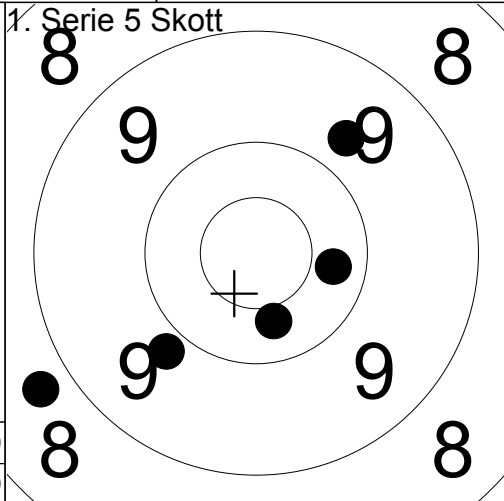

1:	10.3	→
2:	9.7	↗
3:	9.8	↙
4:	8.7	↙
5:	10.4	↓
Serie		46.0
Total		46.0

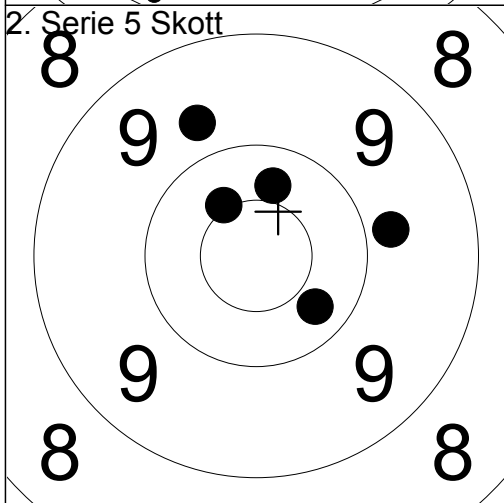

1:	*10.4	↗
2:	9.7	↗
3:	10.3	↗
4:	9.8	→
5:	10.3	↘
Serie		48.0
Total		94.0

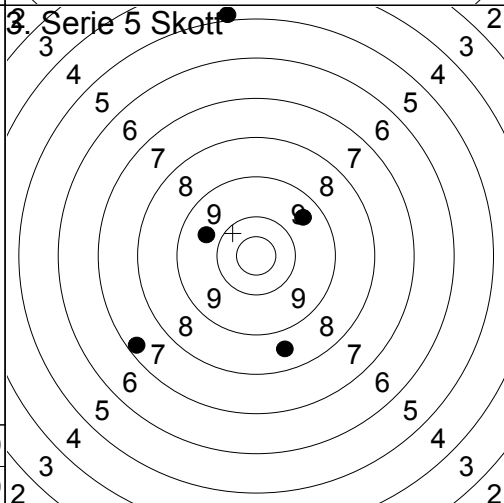

1:	7.3	↙
2:	9.5	↗
3:	9.7	↙
4:	4.9	↑
5:	8.6	↓
Serie		37.0
Total		131.0

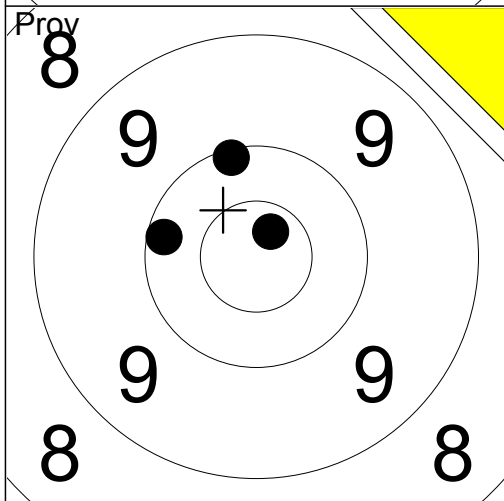

1:	10.2	←
2:	10.1	↑
3:	*10.7	↗
Serie		30.0
Total		131.0

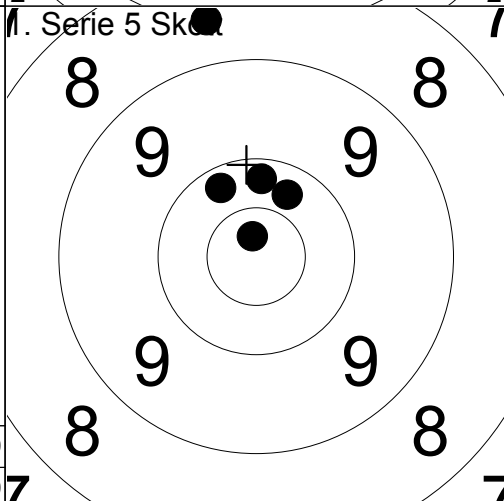

1:	8.6	↑
2:	10.2	↗
3:	10.2	↑
4:	*10.8	↑
5:	10.3	↗
Serie		48.0
Total		179.0

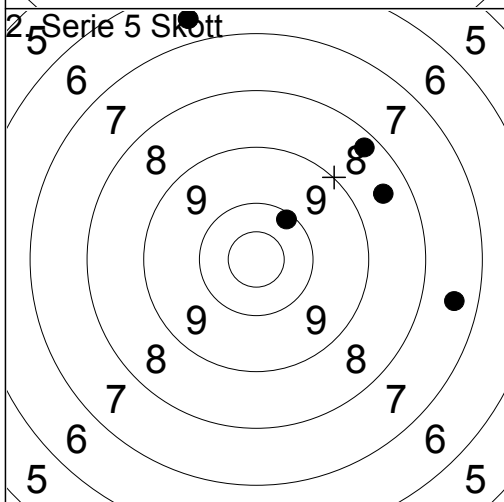

1:	8.3	↗
2:	10.1	↗
3:	8.5	↗
4:	7.5	→
5:	6.6	↑
Serie		39.0
Total		218.0

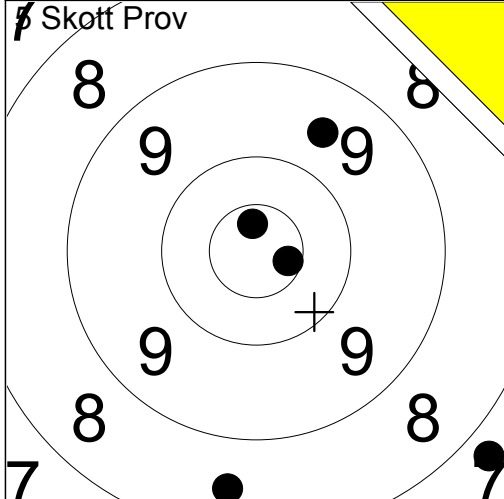

1:	*10.7	↑
2:	8.5	↓
3:	*10.6	→
4:	7.7	↘
5:	9.6	↑
Serie		44.0
Total		0.0

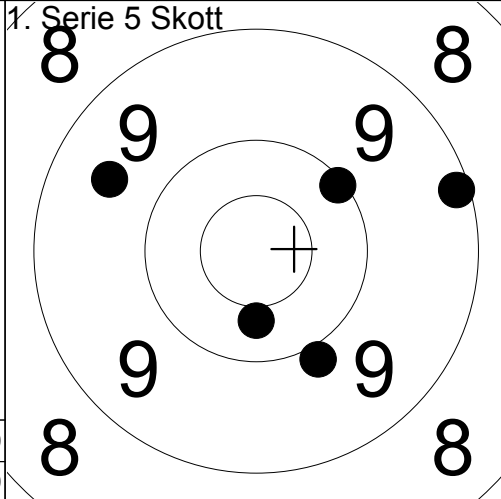

1:	10.1	↗
2:	9.9	↓
3:	9.1	→
4:	9.6	↖
5:	10.4	↓
Serie		47.0
Total		47.0

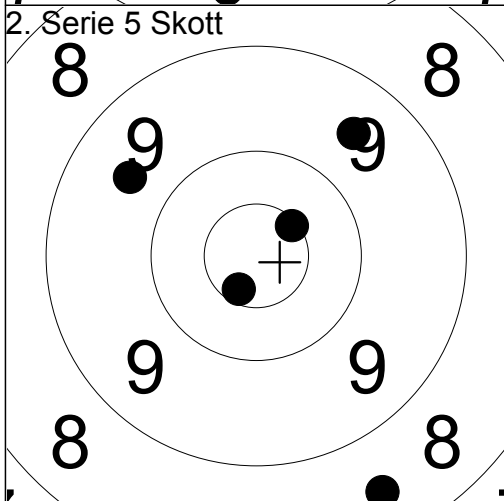

1:	*10.5	↗
2:	9.6	↖
3:	9.5	↗
4:	8.5	↓
5:	*10.6	↓
Serie		46.0
Total		93.0

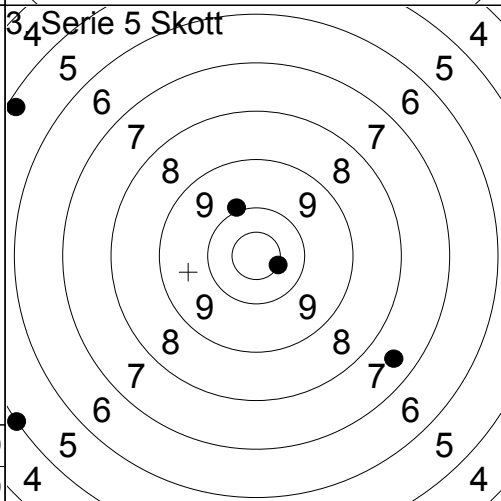

1:	5.2	↖
2:	5.0	↙
3:	*10.5	→
4:	7.5	↘
5:	9.9	↑
Serie		36.0
Total		129.0

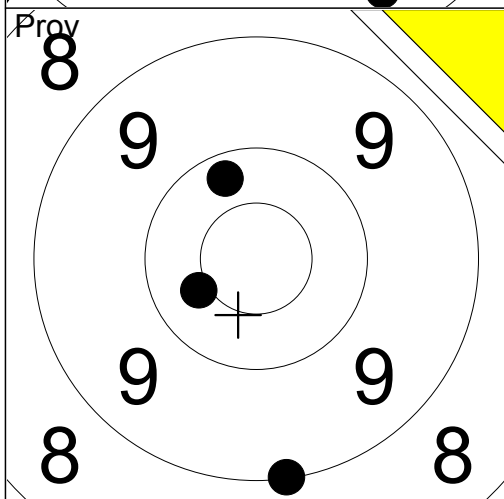

1:	10.2	↑
2:	9.0	↓
3:	10.4	↖
Serie		29.0
Total		129.0

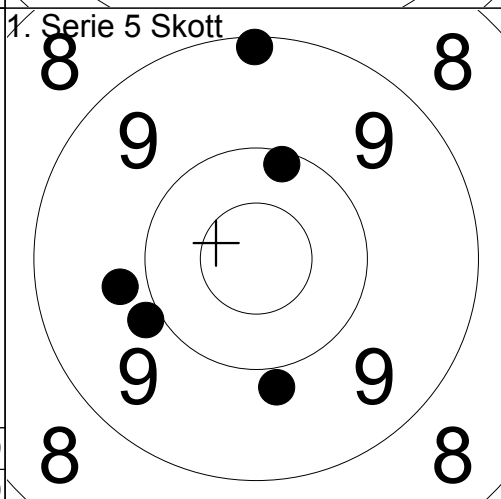

1:	9.1	↑
2:	9.8	←
3:	9.9	↓
4:	9.9	↙
5:	10.1	↑
Serie		46.0
Total		175.0

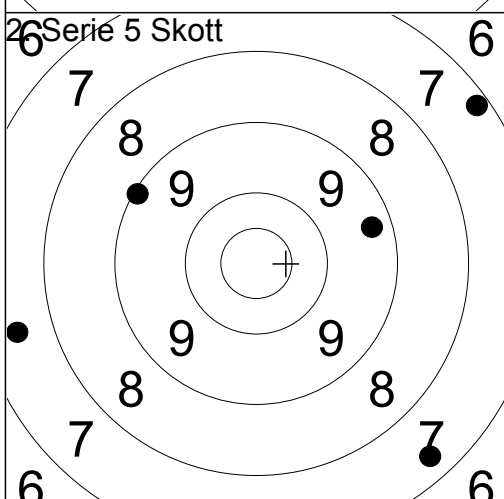

1:	7.2	↗
2:	9.1	↖
3:	9.3	→
4:	7.5	←
5:	7.4	↘
Serie		39.0
Total		214.0

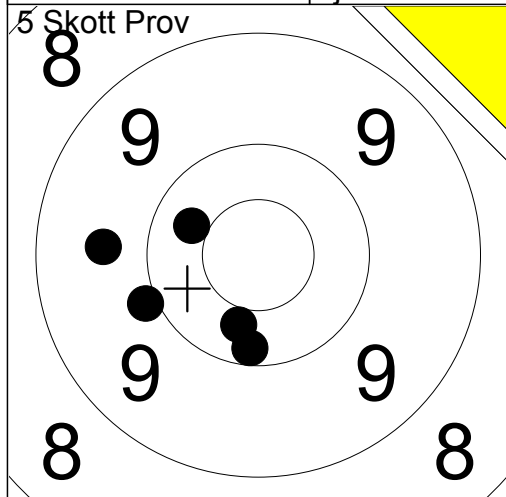

- 1: 10.3 ↖
- 2: 9.6 ←
- 3: 10.3 ↓
- 4: 9.9 ←
- 5: 10.2 ↓

Serie	48.0
Total	0.0

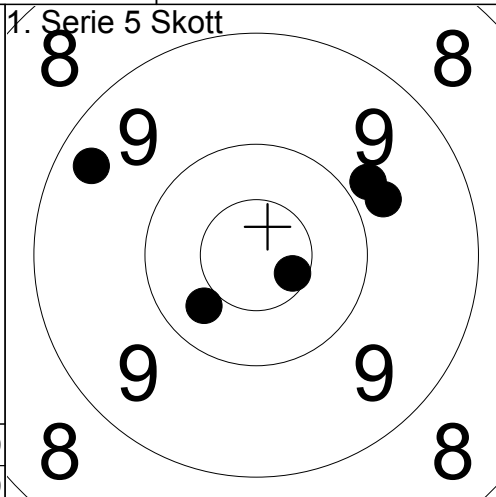

- 1: 9.3 ↗
- 2: 9.8 ↗
- 3: 9.8 ↗
- 4: 10.3 ↘
- 5: *10.6 ↘

Serie	47.0
Total	47.0

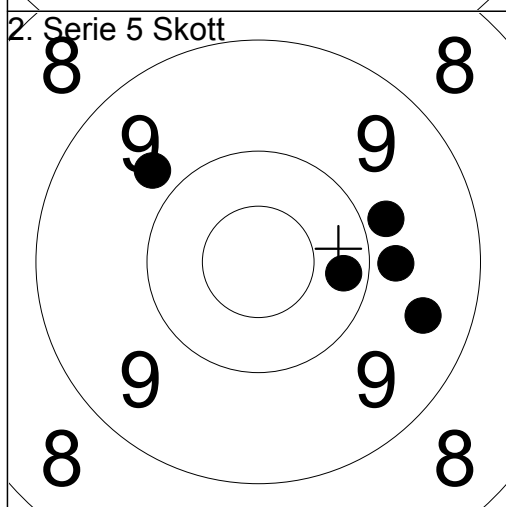

- 1: 9.8 ↗
- 2: 9.8 →
- 3: 9.5 →
- 4: 10.2 →
- 5: 9.8 →

Serie	46.0
Total	93.0

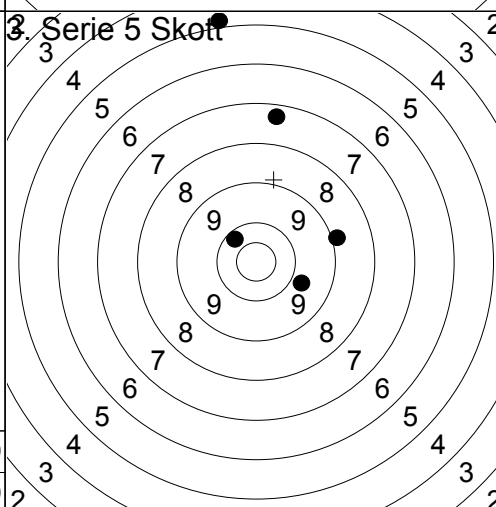

- 1: 10.2 ↗
- 2: 9.8 →
- 3: 8.9 →
- 4: 4.9 ↑
- 5: 7.3 ↑

Serie	38.0
Total	131.0

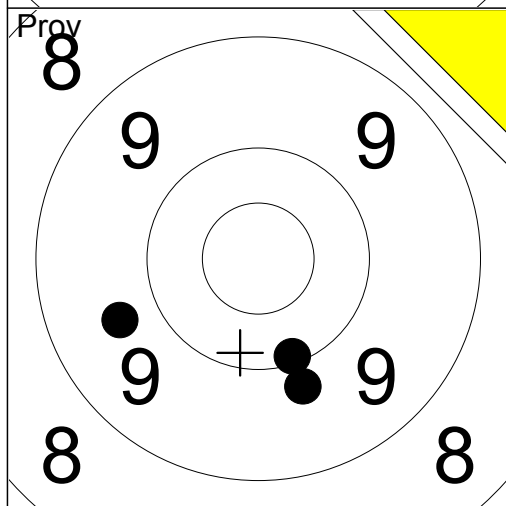

- 1: 10.1 ↓
- 2: 9.8 ↓
- 3: 9.7 ←

Serie	28.0
Total	131.0

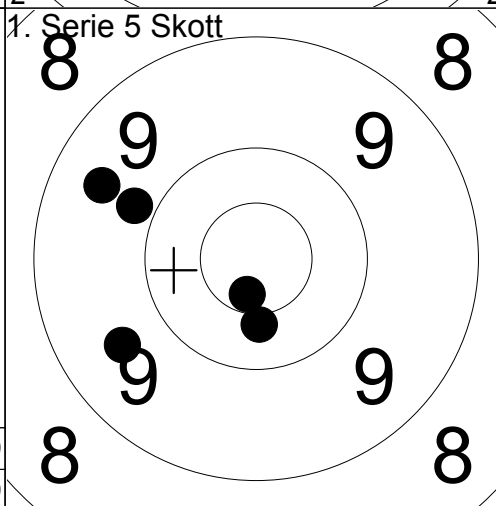

- 1: 9.5 ↖
- 2: 9.6 ↖
- 3: *10.6 ↓
- 4: 9.8 ↖
- 5: 10.4 ↓

Serie	47.0
Total	178.0

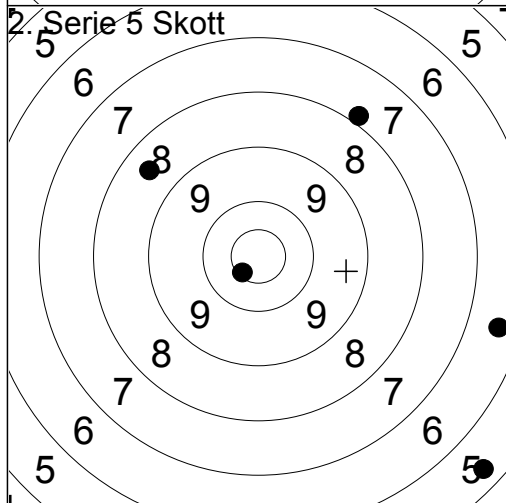

- 1: 7.9 ↗
- 2: *10.6 ↖
- 3: 8.5 ↗
- 4: 6.5 →
- 5: 5.4 ↘

Serie	36.0
Total	214.0

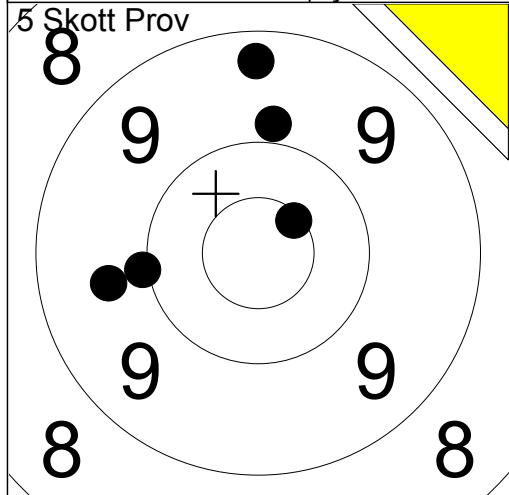

1:	9.3	↑
2:	*10.5	↗
3:	9.9	↑
4:	9.7	←
5:	10.0	←

Serie	47.0
Total	0.0

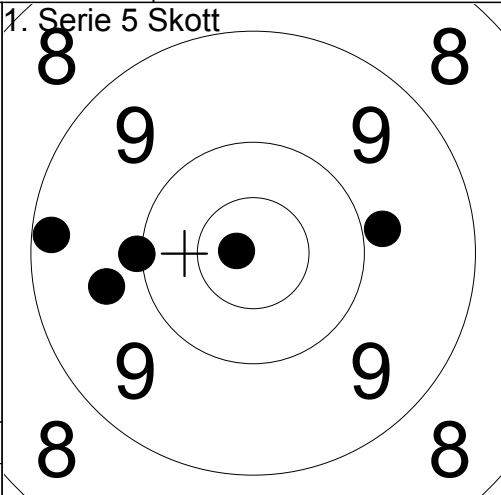

1:	9.2	←
2:	*10.8	←
3:	9.8	→
4:	9.7	←
5:	10.0	←

Serie	47.0
Total	47.0

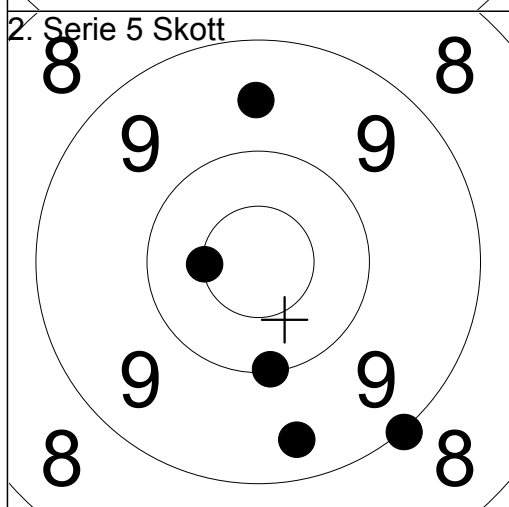

1:	9.6	↑
2:	*10.5	←
3:	10.0	↓
4:	9.4	↓
5:	9.0	↓

Serie	47.0
Total	94.0

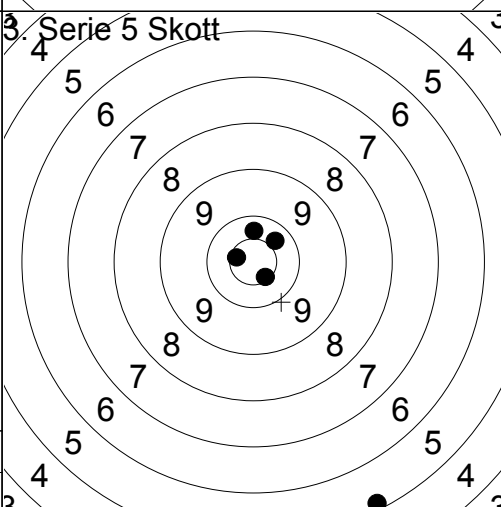

1:	*10.6	↘
2:	*10.6	←
3:	10.3	↗
4:	10.3	↑
5:	5.2	↓

Serie	45.0
Total	139.0

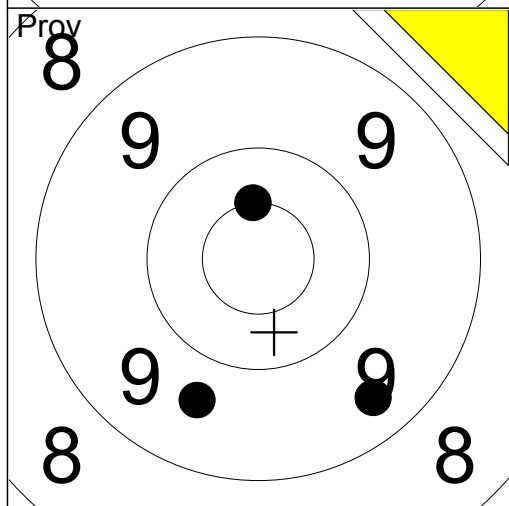

1:	*10.5	↑
2:	9.4	↘
3:	9.6	↓

Serie	28.0
Total	139.0

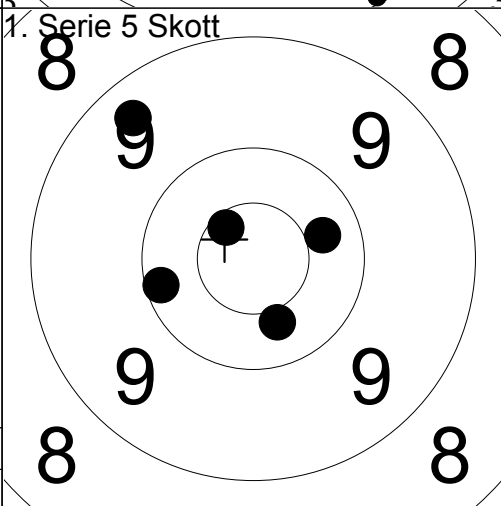

1:	9.4	↗
2:	10.4	↓
3:	10.3	→
4:	10.2	←
5:	*10.6	↗

Serie	49.0
Total	188.0

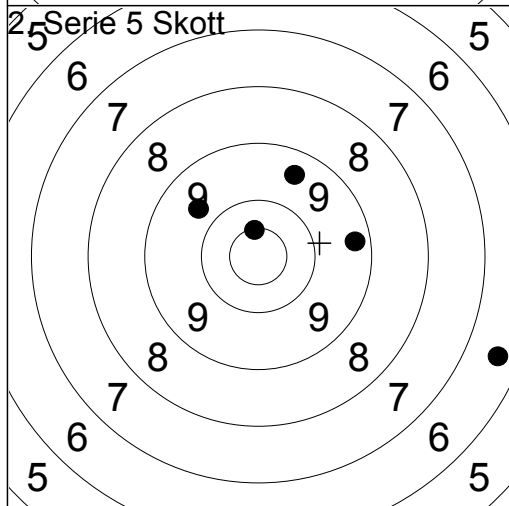

1:	9.5	↗
2:	9.7	↖
3:	*10.5	↑
4:	9.3	→
5:	6.4	↘

Serie	43.0
Total	231.0

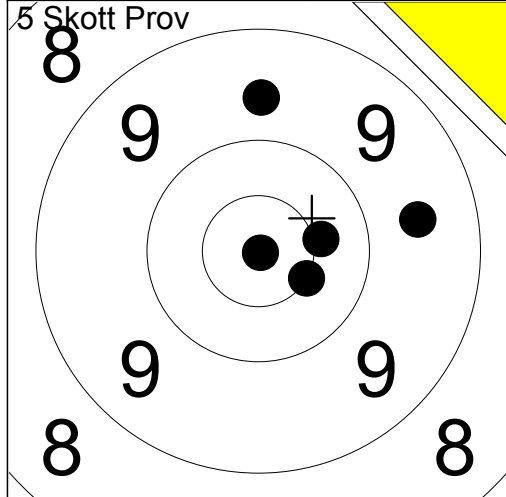

1:	9.6	→
2:	*10.9	↘
3:	9.7	↑
4:	*10.4	→
5:	*10.5	↘

Serie	48.0
Total	0.0

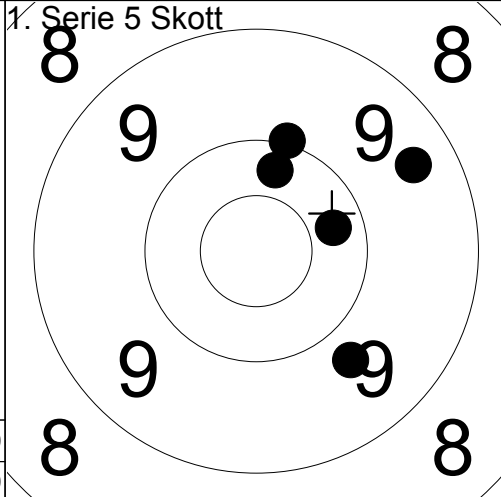

1:	9.4	↗
2:	10.0	↑
3:	10.3	→
4:	10.3	↑
5:	9.7	↘

Serie	48.0
Total	48.0

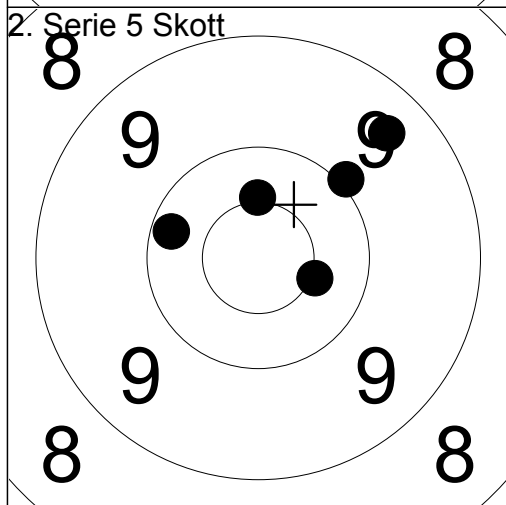

1:	10.0	↗
2:	*10.4	↑
3:	10.2	←
4:	*10.4	→
5:	9.4	↗

Serie	49.0
Total	97.0

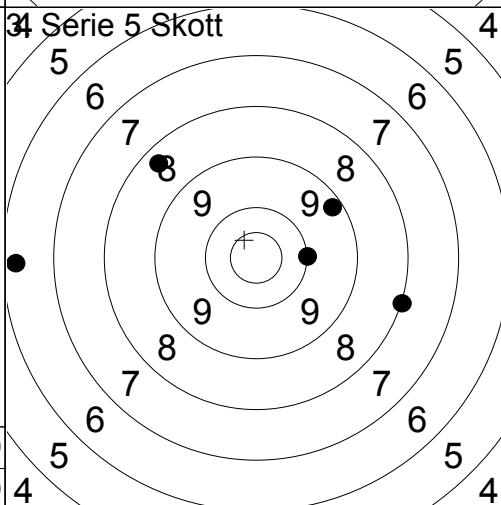

1:	6.3	←
2:	8.0	→
3:	10.0	→
4:	9.2	↗
5:	8.3	↗

Serie	41.0
Total	138.0

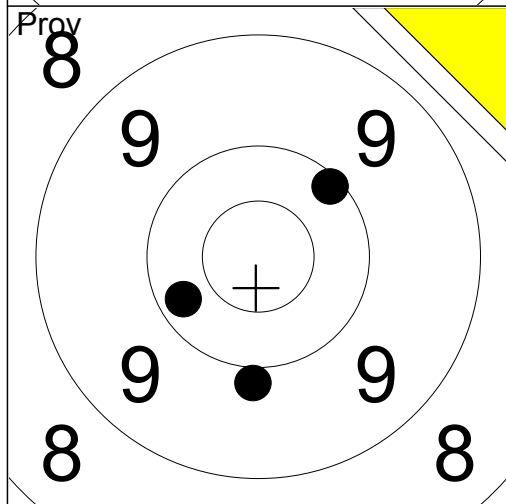

1:	10.1	↗
2:	10.2	←
3:	9.9	↓

Serie	29.0
Total	138.0

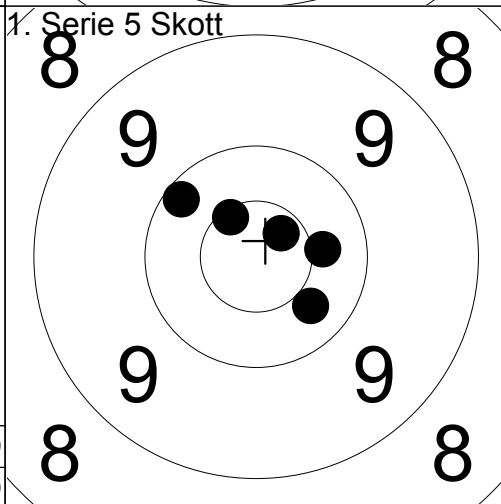

1:	10.2	↗
2:	10.3	↘
3:	*10.6	↗
4:	10.4	→
5:	*10.7	↗

Serie	50.0
Total	188.0

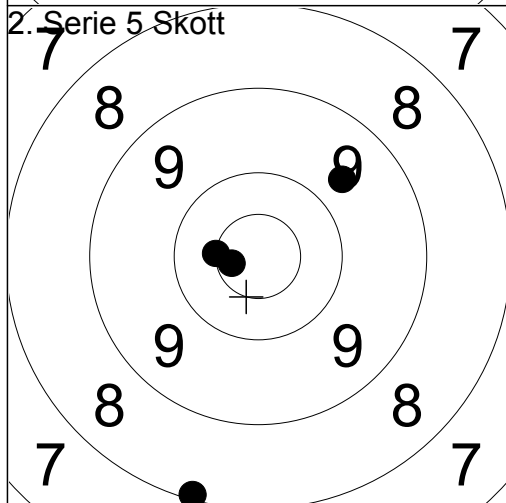

1:	*10.6	←
2:	9.7	↗
3:	*10.5	←
4:	8.1	↓
5:	0.0	

Serie	37.0
Total	225.0

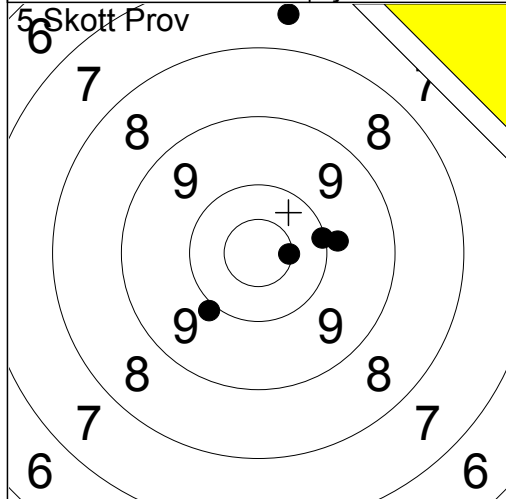

1:	7.5	↑
2:	9.9	→
3:	*10.5	→
4:	10.1	→
5:	9.9	↙
Serie	45.0	
Total	0.0	

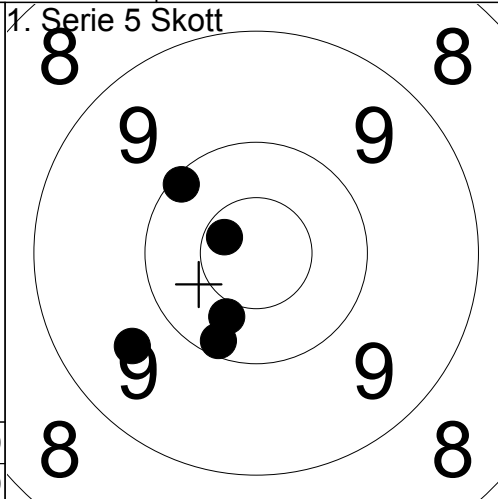

1:	10.4	↘
2:	9.6	↙
3:	10.1	↗
4:	*10.7	↖
5:	10.2	↘
Serie	49.0	
Total	49.0	

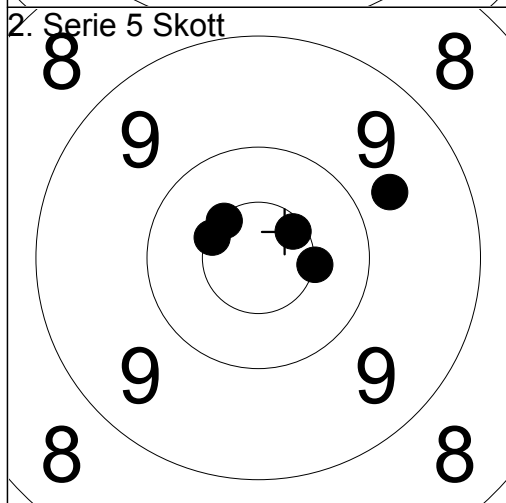

1:	*10.6	↗
2:	*10.5	↗
3:	*10.5	↖
4:	*10.5	→
5:	9.7	↗
Serie	49.0	
Total	98.0	

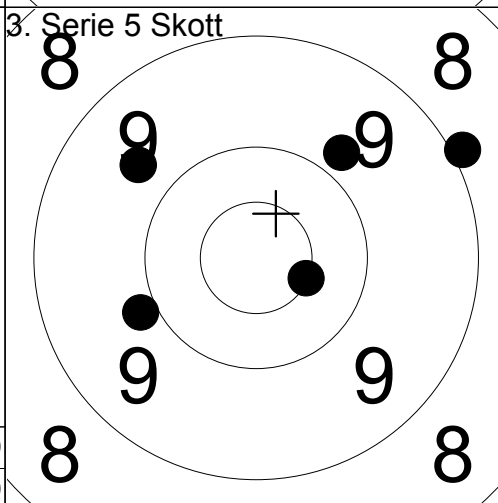

1:	9.7	↖
2:	9.8	↗
3:	9.9	↖
4:	*10.5	→
5:	8.9	↗
Serie	45.0	
Total	143.0	

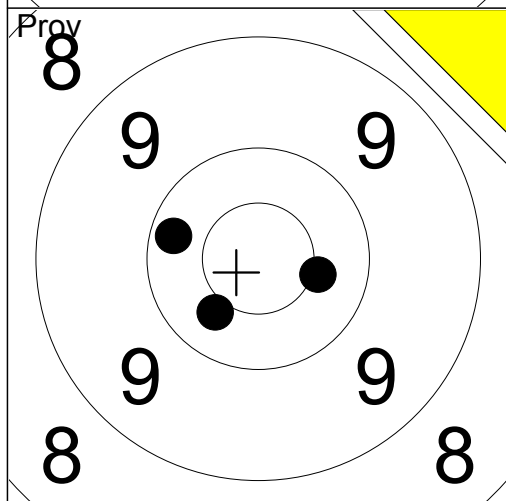

1:	10.2	↖
2:	10.4	↘
3:	*10.4	→
Serie	30.0	
Total	143.0	

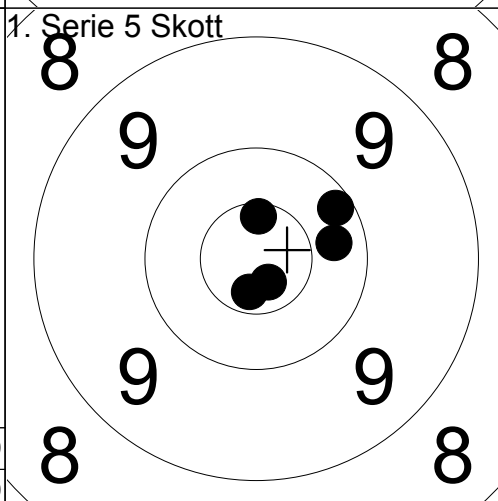

1:	*10.7	↘
2:	10.3	→
3:	*10.6	↑
4:	*10.7	↘
5:	10.2	↗
Serie	50.0	
Total	193.0	

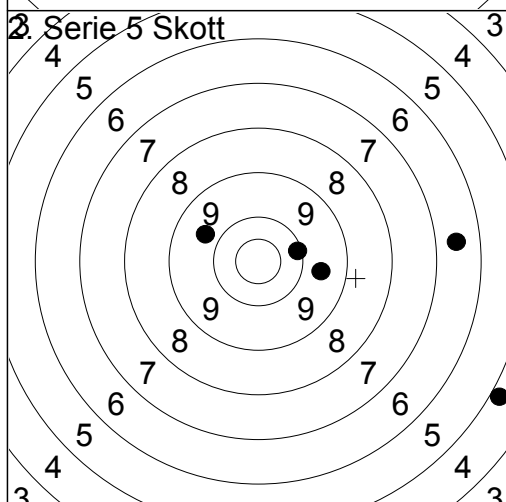

1:	9.7	↗
2:	10.1	→
3:	9.6	→
4:	4.8	↘
5:	6.6	→
Serie	38.0	
Total	231.0	

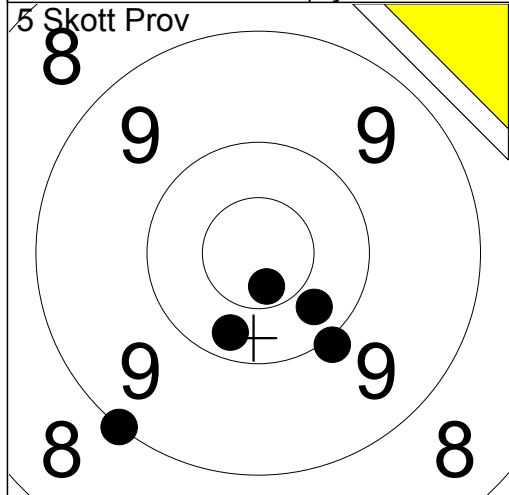

1:	10.0	↘
2:	10.3	↘
3:	*10.7	↘
4:	9.0	↘
5:	10.2	↘
Serie		49.0
Total		0.0

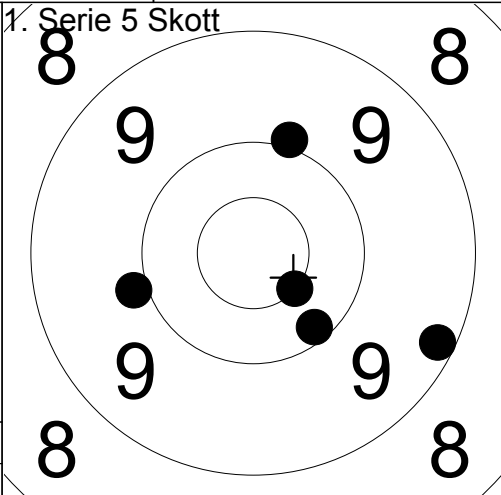

1:	10.0	↑
2:	10.1	↘
3:	9.9	←
4:	9.2	↘
5:	*10.5	↘
Serie		48.0
Total		48.0

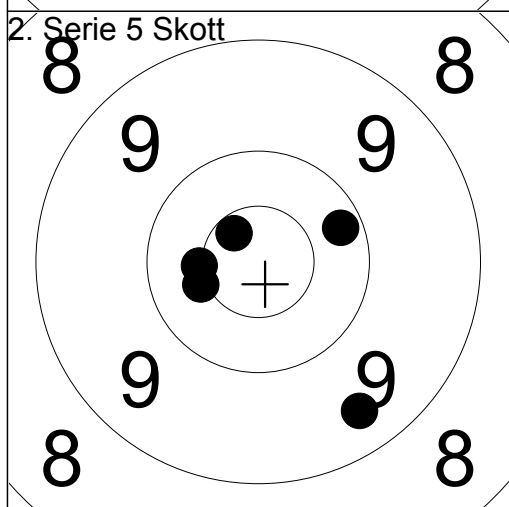

1:	10.2	→
2:	*10.6	↗
3:	9.4	↘
4:	*10.4	←
5:	*10.5	←
Serie		49.0
Total		97.0

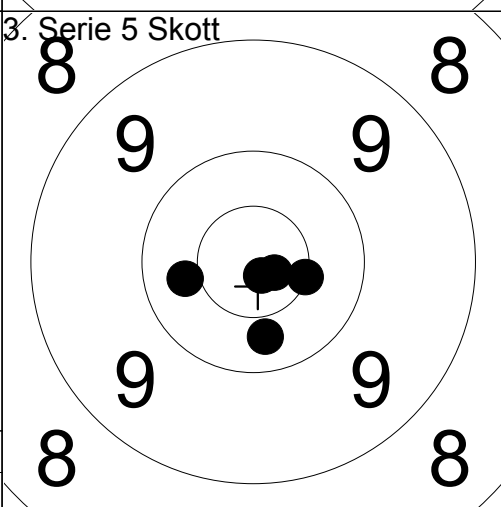

1:	*10.5	→
2:	10.4	←
3:	*10.8	↘
4:	*10.8	↘
5:	10.3	↘
Serie		50.0
Total		147.0

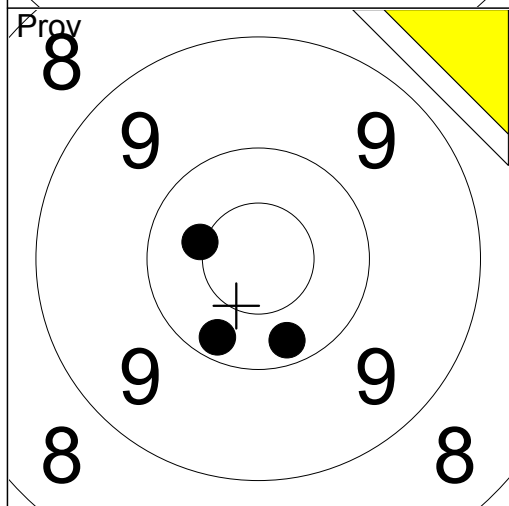

1:	*10.4	←
2:	10.2	↘
3:	10.2	↘
Serie		30.0
Total		147.0

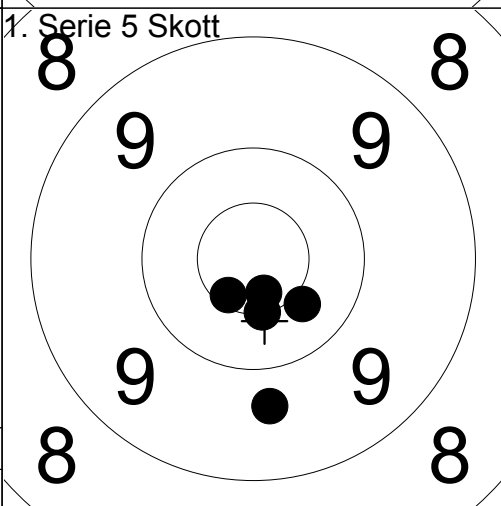

1:	*10.5	↘
2:	*10.6	↘
3:	*10.7	↘
4:	10.4	↘
5:	9.7	↘
Serie		49.0
Total		196.0

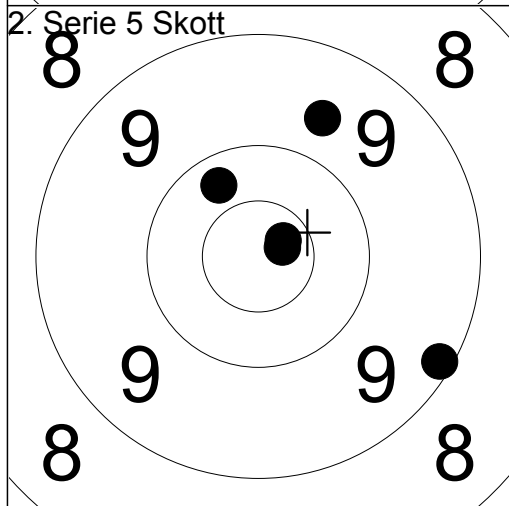

1:	9.7	↗
2:	10.3	↗
3:	*10.7	→
4:	*10.7	↗
5:	9.1	↘
Serie		48.0
Total		244.0

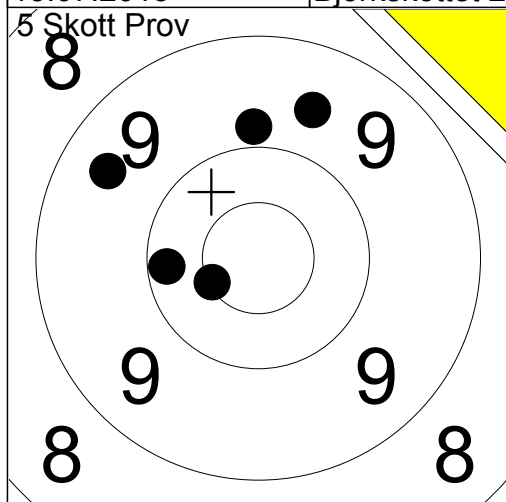

1:	9.8	↑
2:	9.6	↑
3:	*10.5	↙
4:	9.5	↖
5:	10.2	←

Serie	47.0
Total	0.0

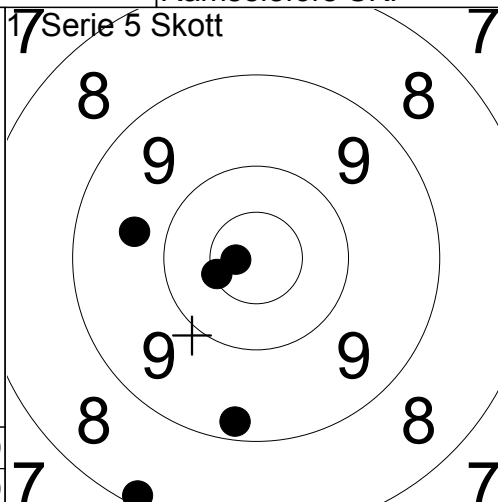

1:	*10.5	↙
2:	*10.7	←
3:	8.1	↘
4:	9.7	↖
5:	9.2	↘

Serie	46.0
Total	46.0

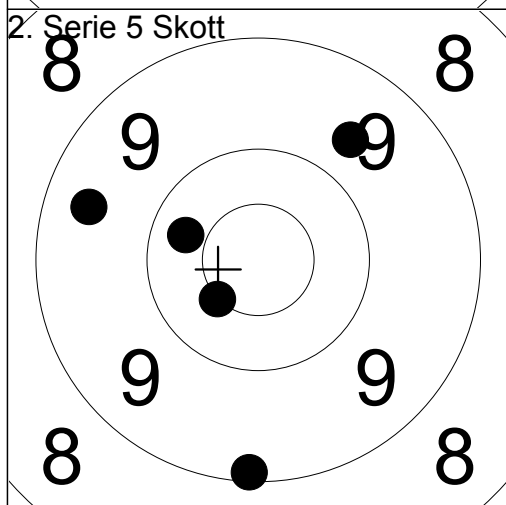

1:	9.1	↘
2:	9.4	↖
3:	9.7	↗
4:	10.3	↖
5:	*10.5	↘

Serie	47.0
Total	93.0

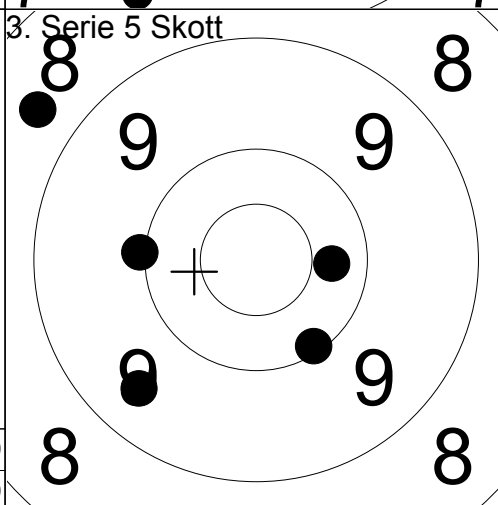

1:	9.5	↘
2:	10.0	←
3:	10.1	↘
4:	10.3	→
5:	8.6	↗

Serie	47.0
Total	140.0

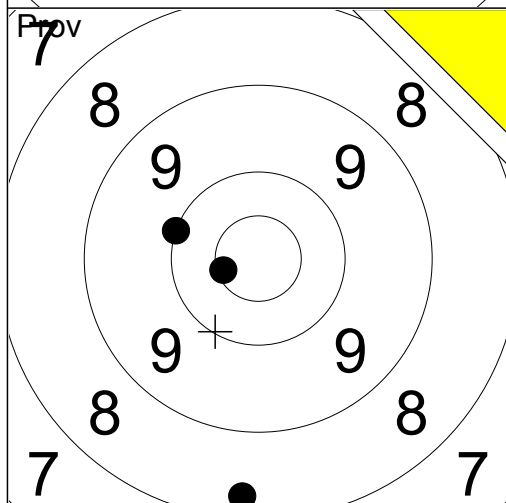

1:	10.0	↖
2:	*10.6	←
3:	8.3	↘

Serie	28.0
Total	140.0

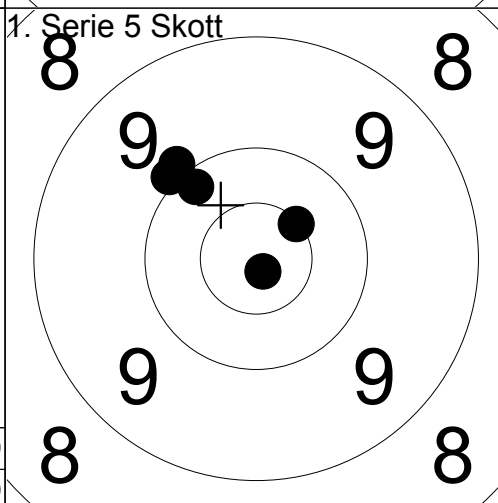

1:	10.2	↗
2:	*10.8	↘
3:	10.0	↗
4:	*10.5	↗
5:	9.9	↗

Serie	49.0
Total	189.0

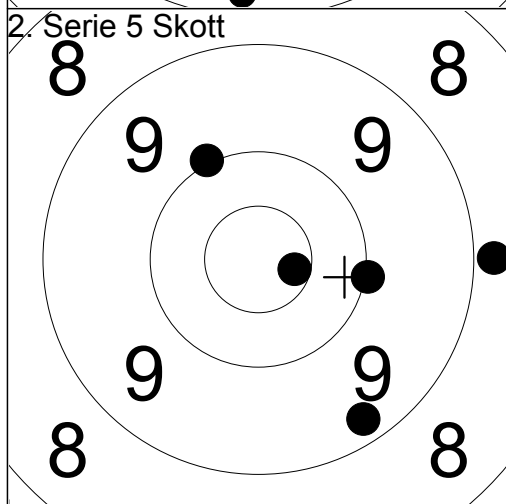

1:	*10.6	→
2:	8.8	→
3:	10.0	→
4:	9.3	↘
5:	10.0	↗

Serie	47.0
Total	236.0

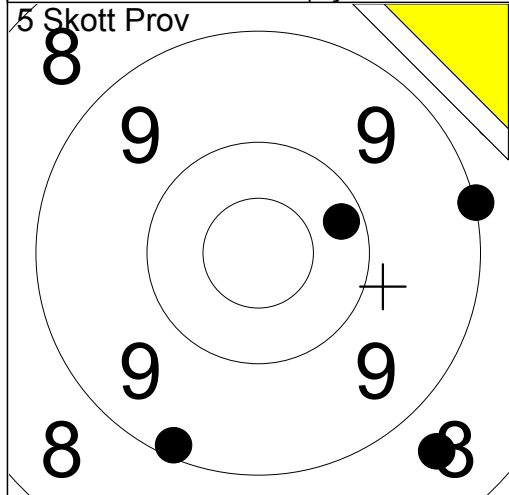

1:	9.0	→
2:	8.6	↗
3:	8.6	↘
4:	10.2	→
5:	9.1	↘
Serie		44.0
Total		0.0

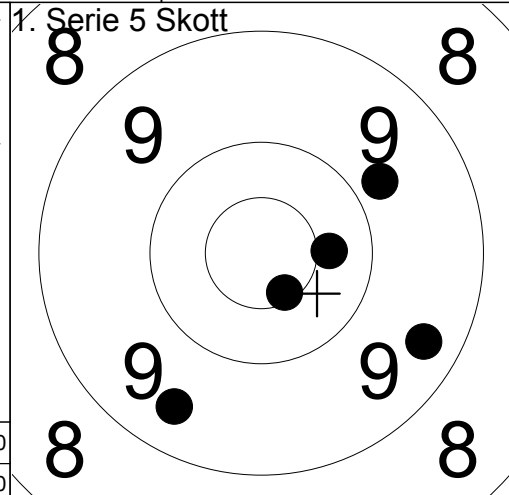

1:	9.4	↘
2:	9.4	↘
3:	10.4	→
4:	9.8	↗
5:	*10.6	↘
Serie		47.0
Total		47.0

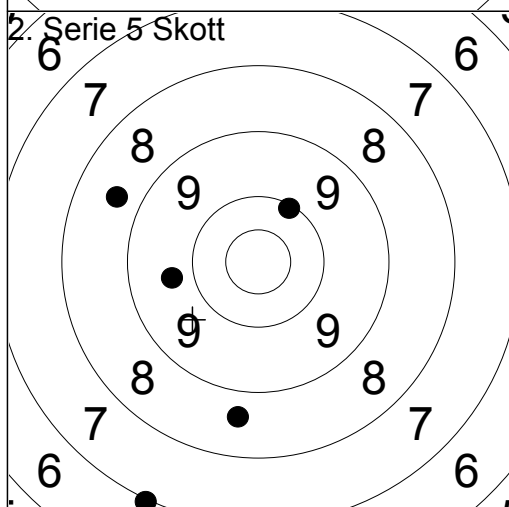

1:	8.6	↘
2:	8.7	↖
3:	10.1	↗
4:	7.0	↘
5:	9.7	←
Serie		42.0
Total		89.0

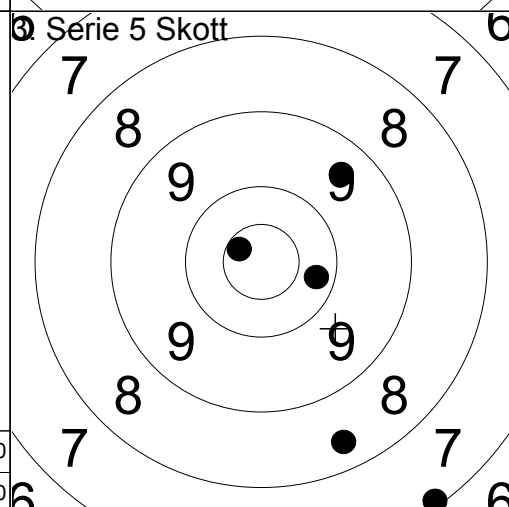

1:	10.2	→
2:	*10.6	↗
3:	8.4	↘
4:	7.1	↘
5:	9.5	↗
Serie		44.0
Total		133.0

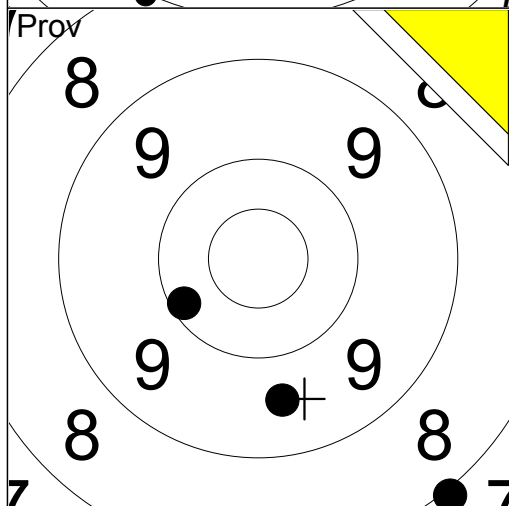

1:	9.6	↘
2:	10.1	↖
3:	8.0	↘
Serie		27.0
Total		133.0

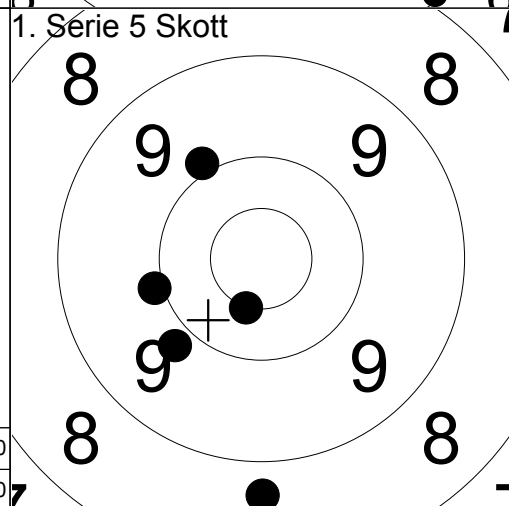

1:	8.7	↘
2:	*10.5	↘
3:	9.9	↗
4:	9.8	↘
5:	9.9	←
Serie		45.0
Total		178.0

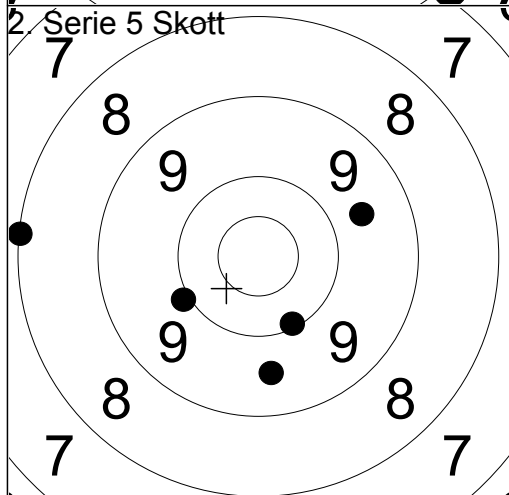

1:	9.6	↗
2:	10.0	↖
3:	8.0	←
4:	9.6	↘
5:	10.1	↘
Serie		46.0
Total		224.0

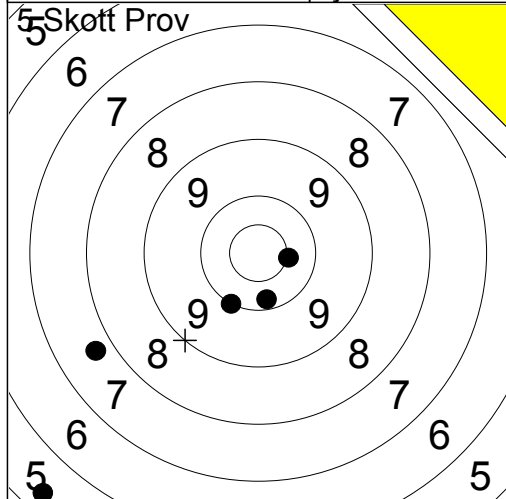

1:	5.4	↙
2:	10.2	↓
3:	*10.5	→
4:	7.7	↙
5:	10.0	↓

Serie	42.0
Total	0.0

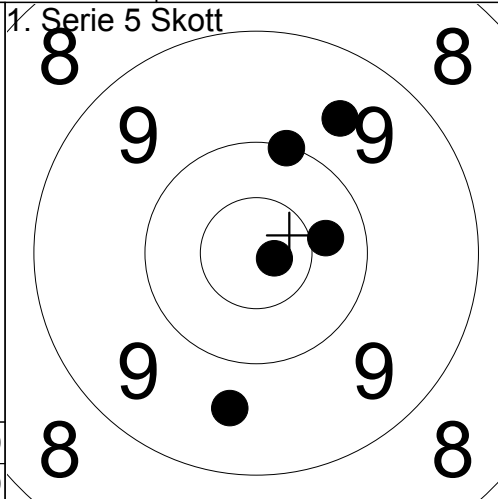

1:	9.6	↓
2:	10.4	→
3:	9.6	↗
4:	10.0	↑
5:	*10.8	→

Serie	48.0
Total	48.0

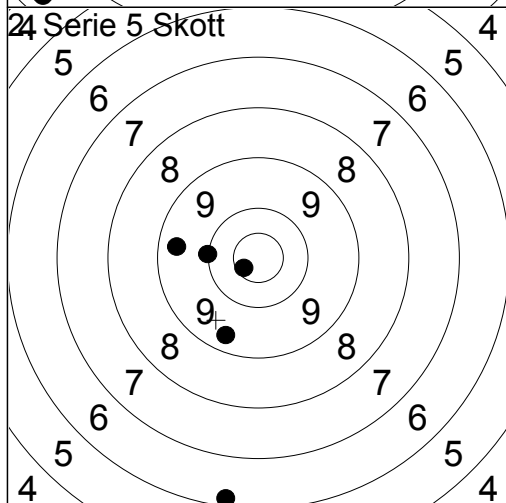

1:	9.4	←
2:	*10.6	↙
3:	10.0	←
4:	6.2	↓
5:	9.4	↓

Serie	44.0
Total	92.0

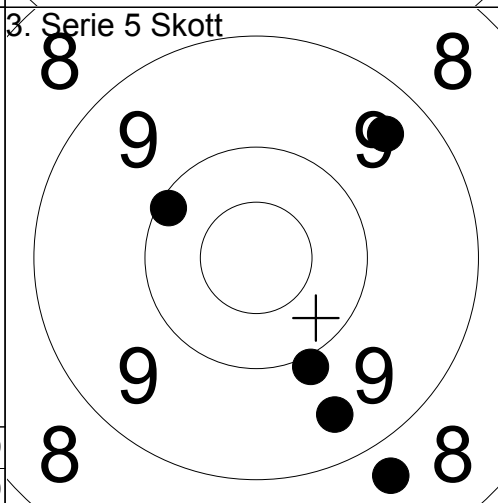

1:	8.7	↘
2:	9.4	↗
3:	10.1	↖
4:	9.5	↓
5:	9.9	↓

Serie	45.0
Total	137.0

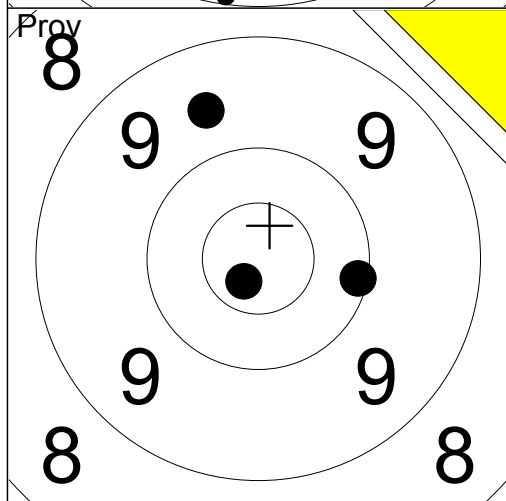

1:	9.6	↑
2:	*10.7	↓
3:	10.1	→

Serie	29.0
Total	137.0

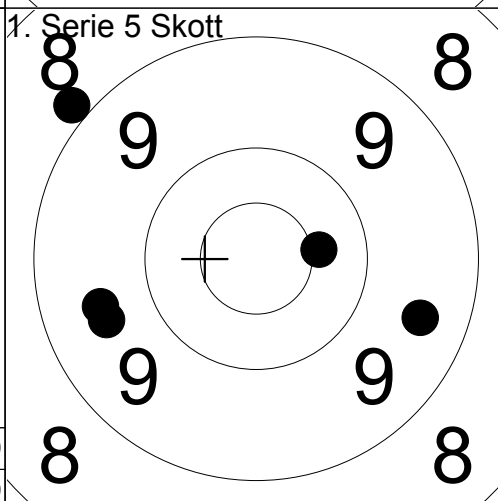

1:	8.9	↖
2:	9.6	←
3:	9.6	←
4:	*10.4	→
5:	9.5	↘

Serie	45.0
Total	182.0

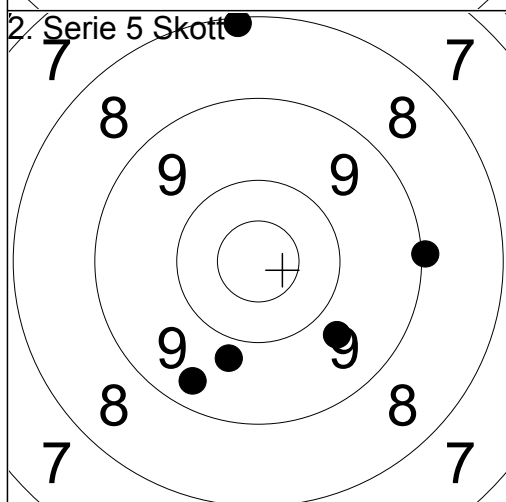

1:	9.0	→
2:	8.1	↑
3:	9.4	↙
4:	9.8	↓
5:	9.7	↘

Serie	44.0
Total	226.0

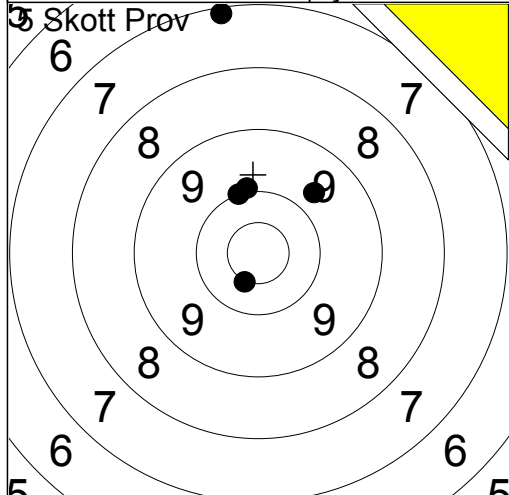

1:	7.1	↑
2:	*10.5	↓
3:	10.0	↑
4:	10.0	↑
5:	9.7	↗
Serie	46.0	
Total	0.0	

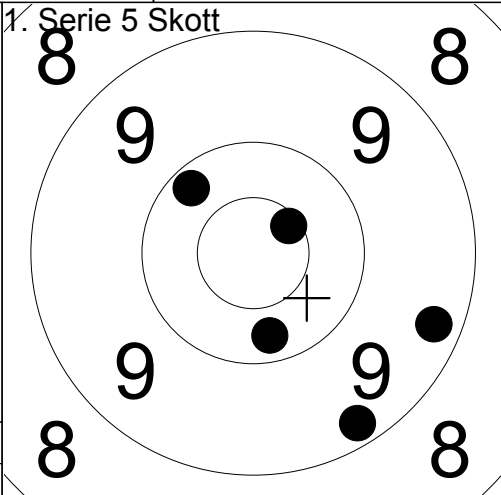

1:	9.3	→
2:	10.2	↗
3:	*10.6	↗
4:	10.3	↓
5:	9.2	↓
Serie	48.0	
Total	48.0	

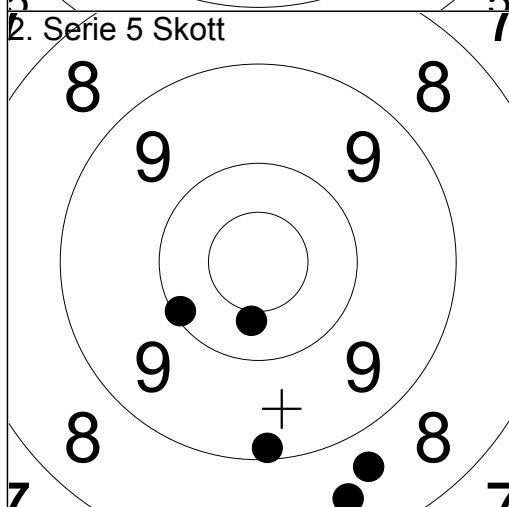

1:	8.7	↓
2:	8.5	↓
3:	9.2	↓
4:	10.4	↓
5:	10.1	↙
Serie	45.0	
Total	93.0	

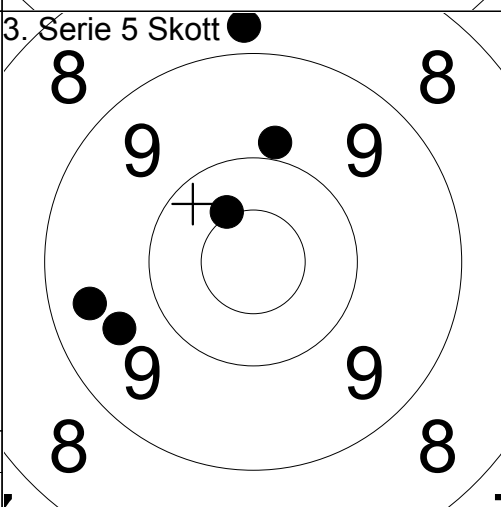

1:	8.8	↑
2:	9.4	←
3:	*10.4	↖
4:	9.6	←
5:	9.9	↑
Serie	45.0	
Total	138.0	

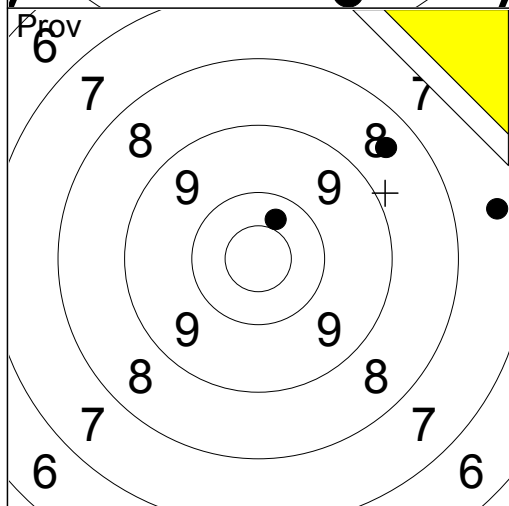

1:	7.4	→
2:	10.4	↑
3:	8.5	↗
Serie	25.0	
Total	138.0	

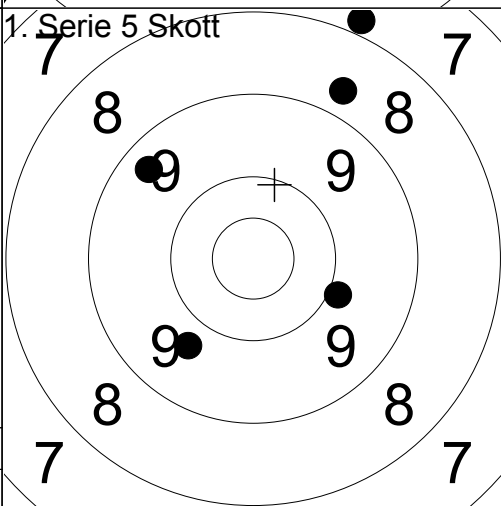

1:	9.7	↙
2:	8.7	↑
3:	9.9	→
4:	9.4	↗
5:	7.9	↑
Serie	42.0	
Total	180.0	

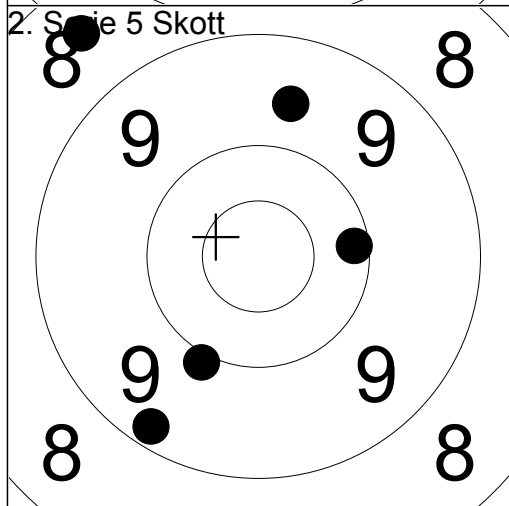

1:	9.6	↑
2:	8.5	↖
3:	10.0	↓
4:	10.1	→
5:	9.2	↓
Serie	46.0	
Total	226.0	

5 Skott Prov

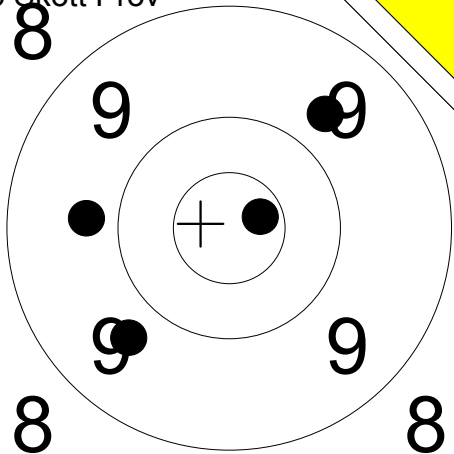

- 1: 9.7 ↙
- 2: 9.7 ←
- 3: 9.7 ↗
- 4: *10.7 →

Serie	37.0
Total	0.0

1. Serie 5 Skott

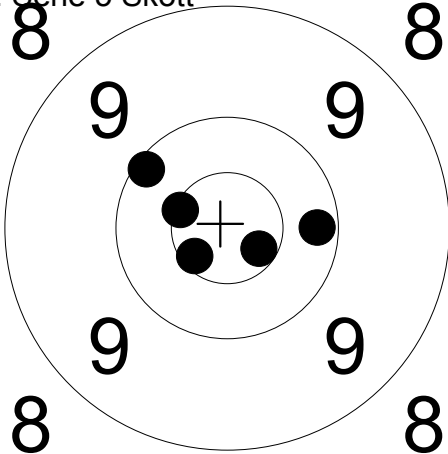

- 1: *10.6 ↘
- 2: *10.6 ↙
- 3: 10.2 →
- 4: 10.1 ↗
- 5: *10.5 ↖

Serie	50.0
Total	50.0

2. Serie 5 Skott

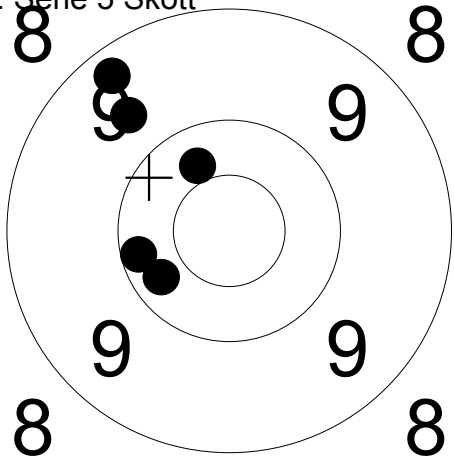

- 1: 10.2 ←
- 2: 9.6 ↗
- 3: 9.3 ↗
- 4: 10.3 ↙
- 5: 10.3 ↗

Serie	48.0
Total	98.0

3. Serie 5 Skott

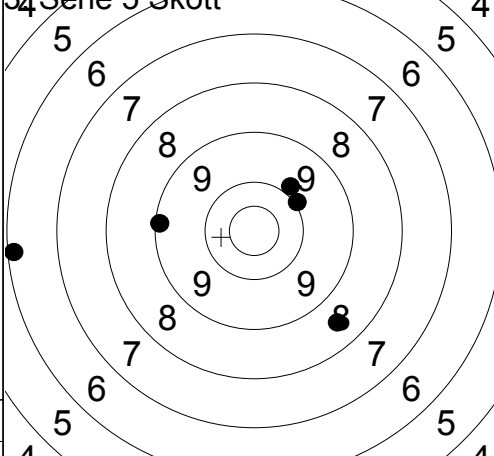

- 1: 10.0 ↗
- 2: 9.9 ↗
- 3: 9.1 ←
- 4: 8.5 ↘
- 5: 6.1 ←

Serie	42.0
Total	140.0

Prov

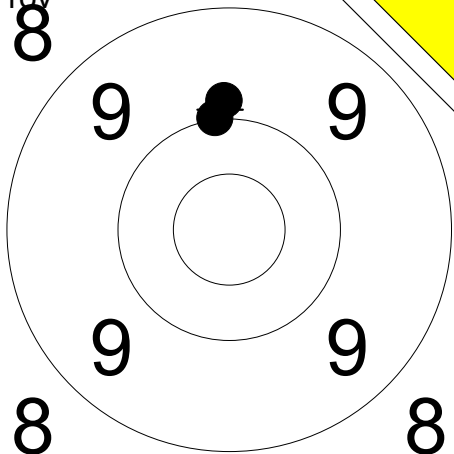

- 1: 9.9 ↑
- 2: 10.0 ↑

Serie	19.0
Total	140.0

1. Serie 5 Skott

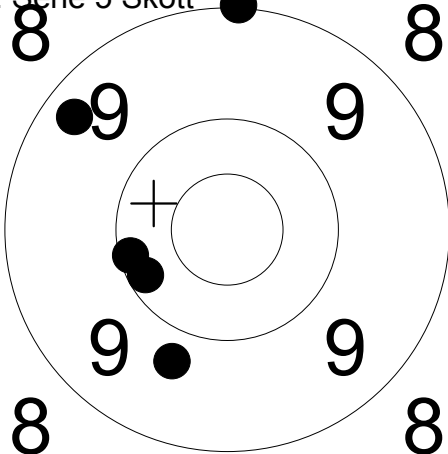

- 1: 10.2 ↙
- 2: 9.7 ↘
- 3: 10.1 ←
- 4: 9.3 ↗
- 5: 9.0 ↑

Serie	47.0
Total	187.0

2. Serie 5 Skott

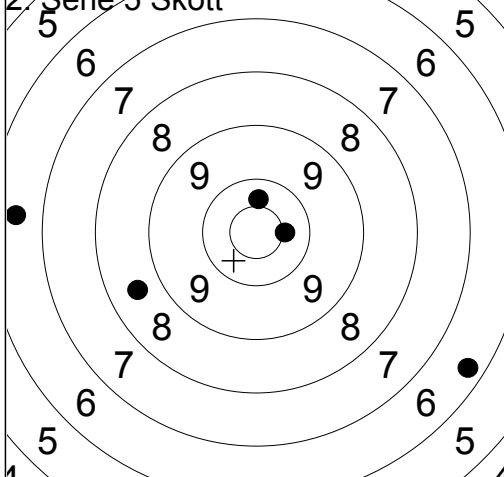

- 1: *10.5 →
- 2: 8.6 ↙
- 3: 10.4 ↑
- 4: 6.5 ←
- 5: 6.3 ↘

Serie	40.0
Total	227.0

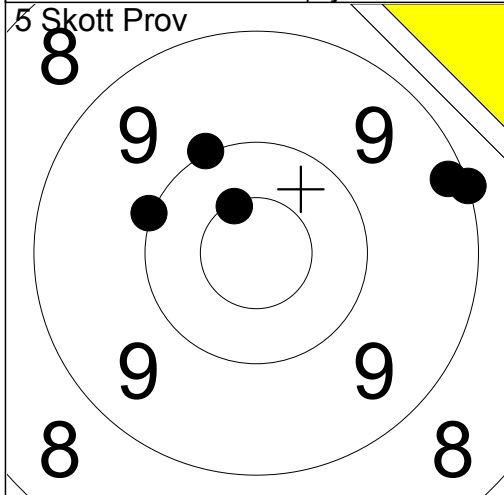

1:	9.0	→
2:	*10.5	↗
3:	9.2	→
4:	10.0	↗
5:	10.0	↖

Serie	48.0
Total	0.0

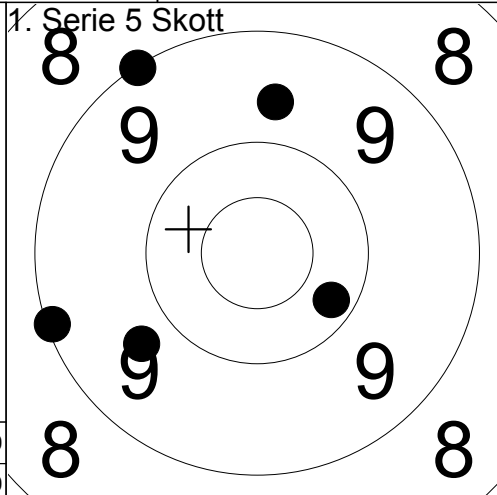

1:	9.0	↖
2:	10.2	↘
3:	9.7	↑
4:	9.1	←
5:	9.7	↙

Serie	46.0
Total	46.0

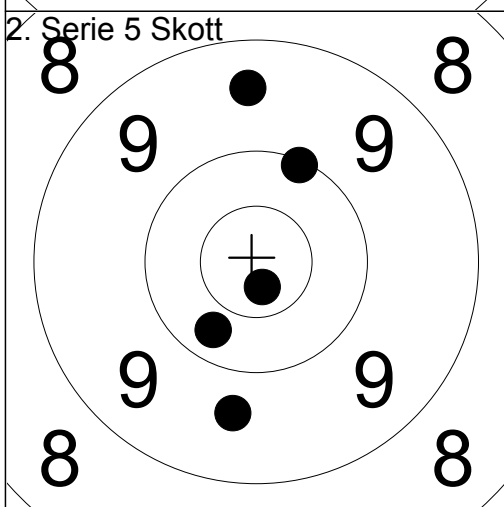

1:	9.5	↑
2:	10.1	↗
3:	10.3	↘
4:	*10.7	↘
5:	9.7	↘

Serie	48.0
Total	94.0

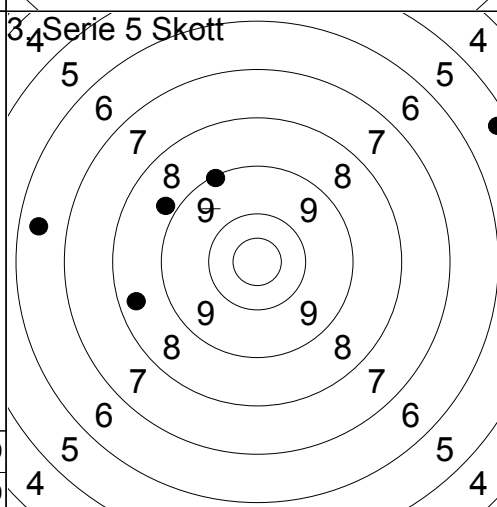

1:	6.4	←
2:	9.1	↗
3:	8.8	↗
4:	8.4	←
5:	5.3	↗

Serie	36.0
Total	130.0

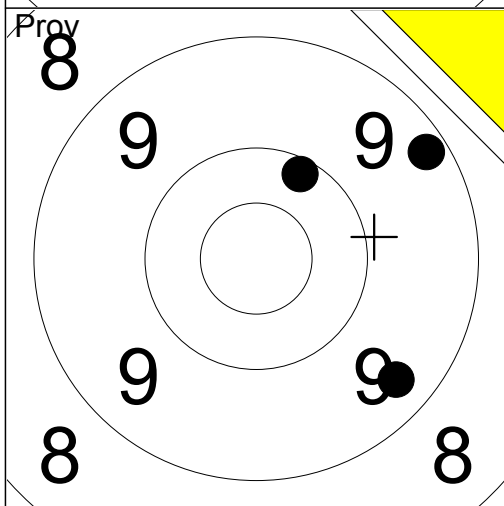

1:	9.4	↘
2:	10.2	↗
3:	9.2	↗

Serie	28.0
Total	130.0

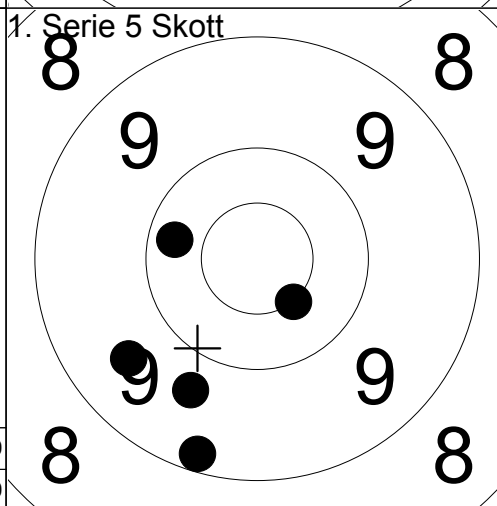

1:	9.2	↘
2:	9.7	↘
3:	9.6	↙
4:	10.2	←
5:	*10.5	↘

Serie	47.0
Total	177.0

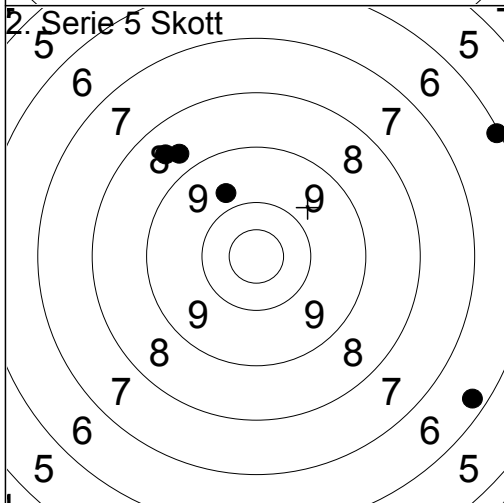

1:	8.5	↗
2:	8.7	↗
3:	9.7	↗
4:	6.1	↗
5:	6.3	↘

Serie	37.0
Total	214.0

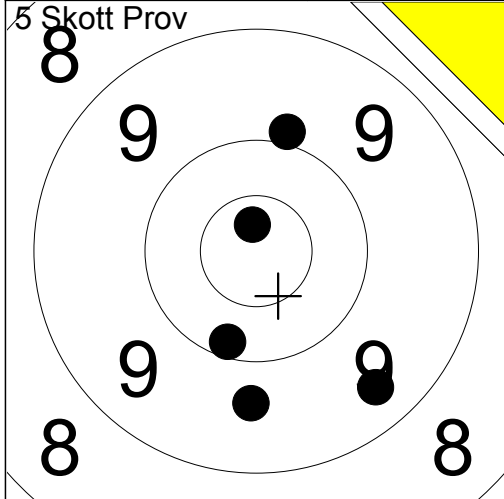

1:	9.9	↑
2:	10.2	↓
3:	9.4	↘
4:	*10.7	↑
5:	9.7	↓
Serie	47.0	
Total	0.0	

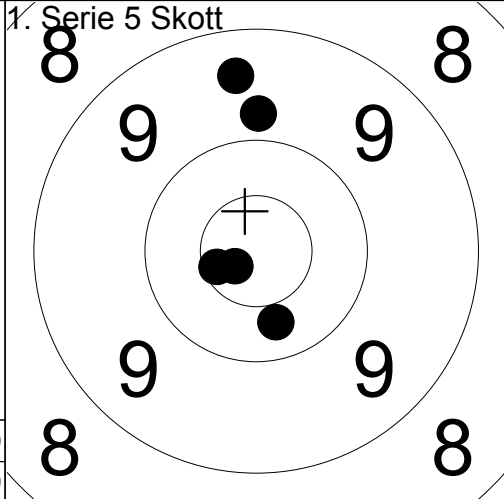

1:	9.8	↑
2:	*10.7	↙
3:	9.4	↑
4:	10.3	↓
5:	*10.6	↙
Serie	48.0	
Total	48.0	

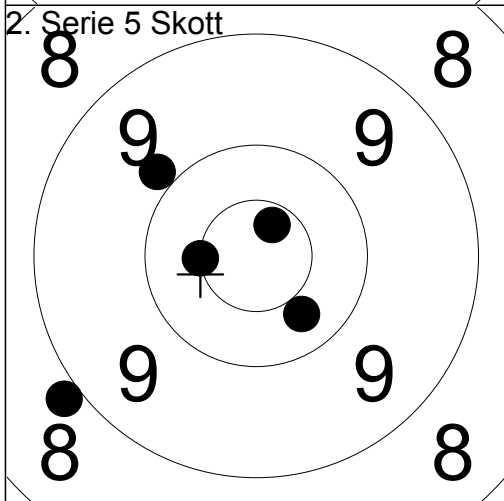

1:	*10.5	←
2:	*10.7	↑
3:	9.9	↗
4:	10.3	↓
5:	8.9	↙
Serie	47.0	
Total	95.0	

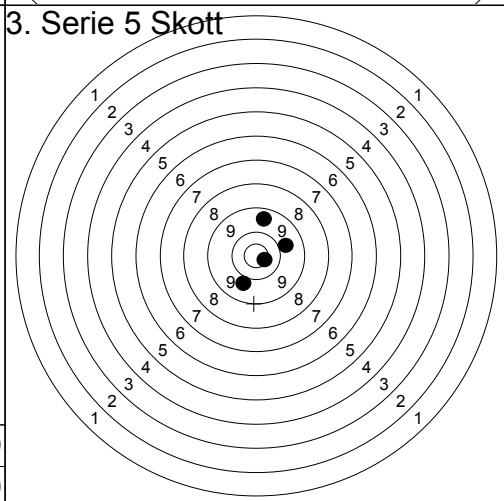

1:	9.5	↑
2:	9.7	→
3:	*10.6	↘
4:	9.8	↓
5:	0.0	↓
Serie	37.0	
Total	132.0	

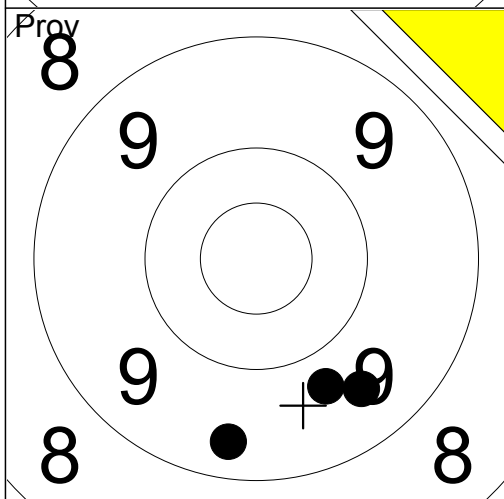

1:	9.7	↓
2:	9.4	↓
3:	9.5	↓
Serie	27.0	
Total	132.0	

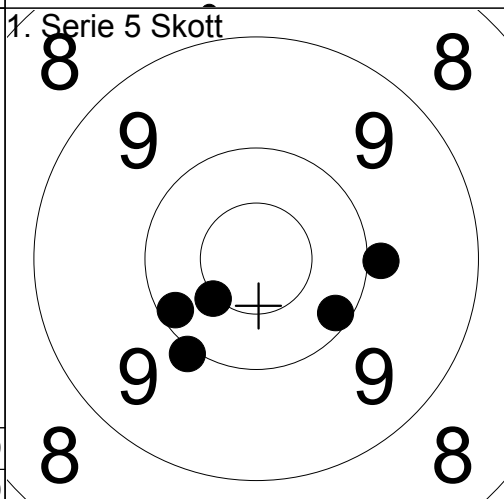

1:	9.9	→
2:	*10.5	↙
3:	10.0	↙
4:	10.1	↘
5:	10.2	↙
Serie	49.0	
Total	181.0	

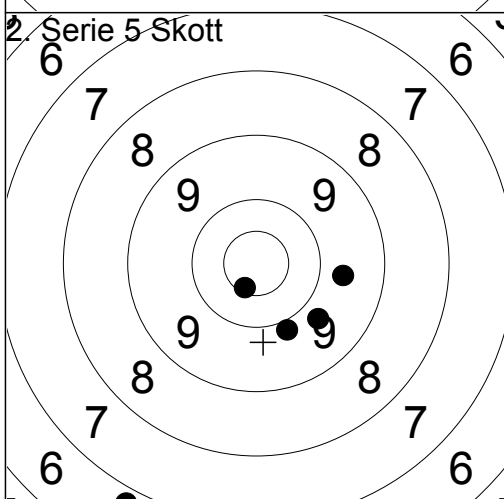

1:	9.7	↓
2:	9.9	↓
3:	*10.6	↓
4:	9.7	→
5:	6.8	↓
Serie	43.0	
Total	224.0	

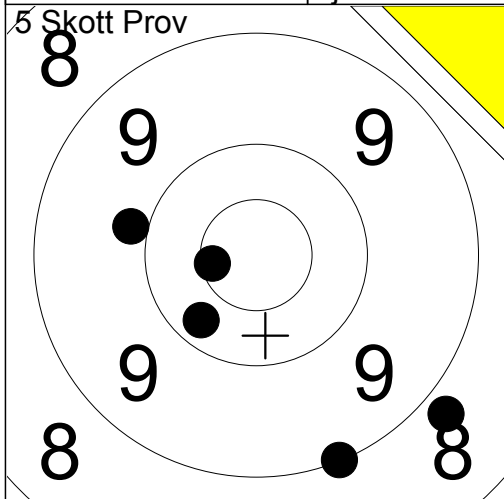

1:	10.2	↙
2:	9.9	←
3:	*10.6	←
4:	8.8	↘
5:	9.0	↘

Serie	46.0
Total	0.0

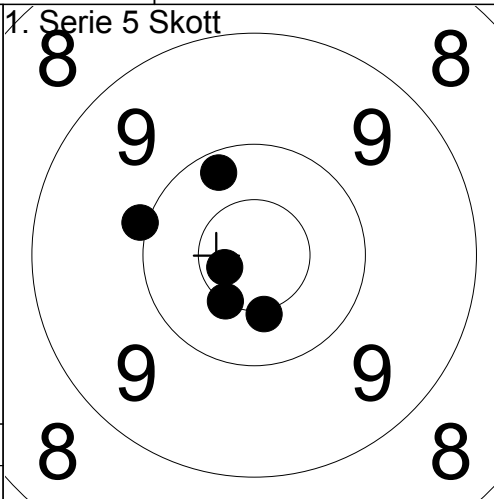

1:	10.2	↗
2:	10.0	←
3:	*10.5	↘
4:	*10.5	↘
5:	*10.7	←

Serie	50.0
Total	50.0

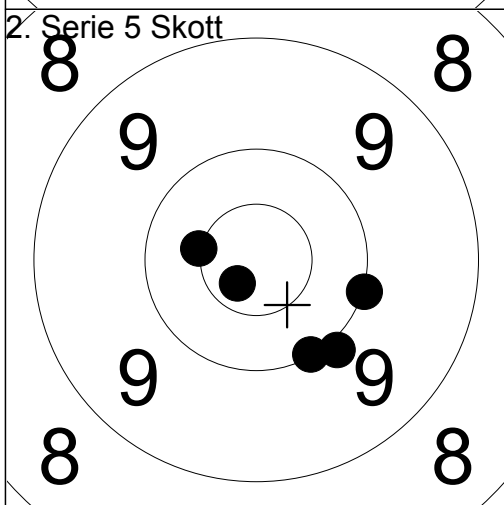

1:	*10.5	←
2:	9.9	↘
3:	*10.7	↘
4:	10.0	→
5:	10.0	↘

Serie	49.0
Total	99.0

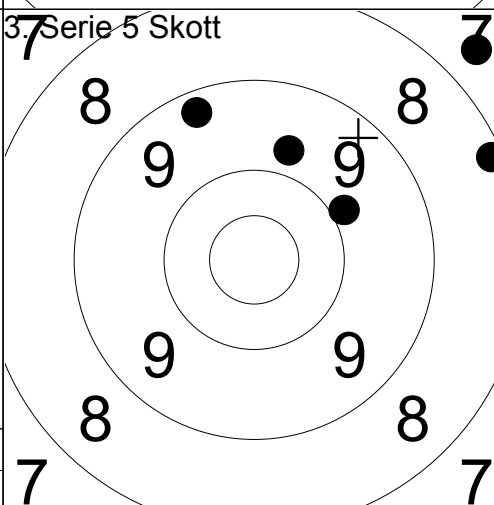

1:	8.2	→
2:	9.9	→
3:	9.8	↑
4:	7.6	↗
5:	9.3	↖

Serie	42.0
Total	141.0

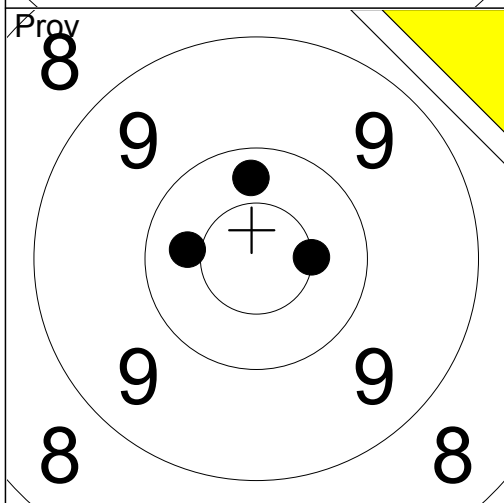

1:	*10.5	→
2:	10.3	↑
3:	10.4	←

Serie	30.0
Total	141.0

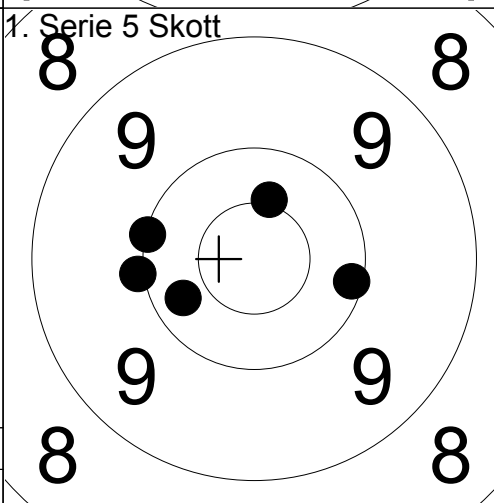

1:	*10.4	↑
2:	10.0	←
3:	10.1	→
4:	10.3	↙
5:	10.0	←

Serie	50.0
Total	191.0

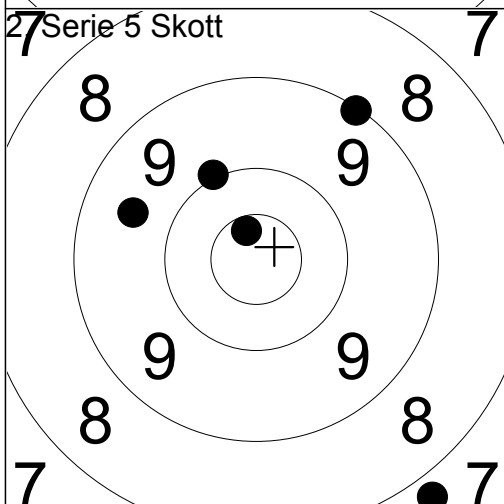

1:	*10.6	↑
2:	9.6	↖
3:	10.0	↗
4:	7.8	↘
5:	9.1	↗

Serie	45.0
Total	236.0

5 Skott Prov

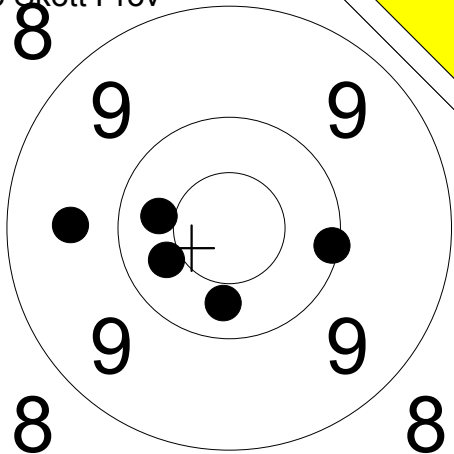

- 1: 10.4 ←
- 2: 9.6 ←
- 3: 10.1 →
- 4: 10.3 ↓
- 5: 10.4 ←

Serie 49.0
Total 0.0

1. Serie 5 Skott

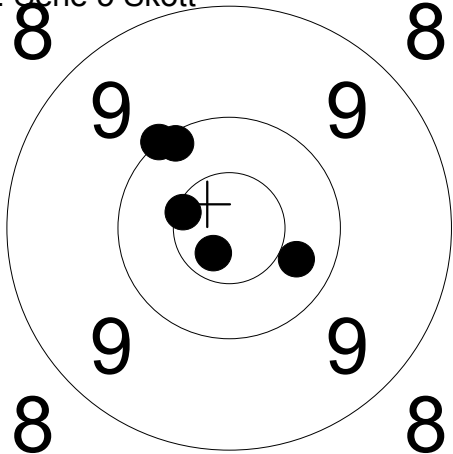

- 1: 10.3 →
- 2: *10.7 ↓
- 3: 10.1 ↗
- 4: 10.0 ↗
- 5: *10.5 ↖

Serie 50.0
Total 50.0

2. Serie 5 Skott

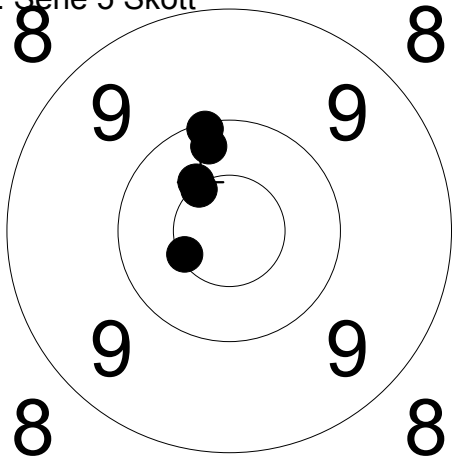

- 1: *10.5 ↗
- 2: 10.1 ↗
- 3: 10.2 ↗
- 4: *10.5 ↗
- 5: *10.5 ↖

Serie 50.0
Total 100.0

3. Serie 5 Skott

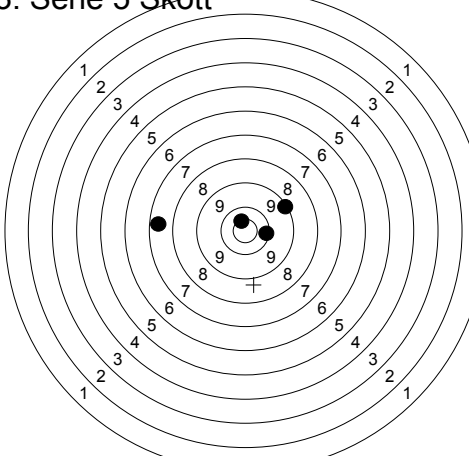

- 1: 9.1 ↗
- 2: 10.1 →
- 3: *10.6 ↗
- 4: 0.0 ↓
- 5: 7.4 ←

Serie 36.0
Total 136.0

Prov

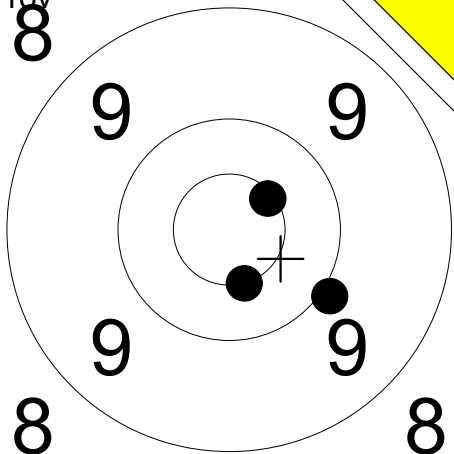

- 1: 9.9 ↘
- 2: *10.5 ↗
- 3: *10.5 ↓

Serie 29.0
Total 136.0

1. Serie 5 Skott

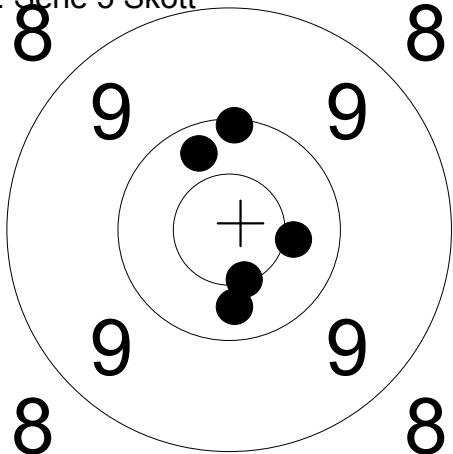

- 1: 10.1 ↑
- 2: 10.4 →
- 3: 10.3 ↓
- 4: *10.5 ↓
- 5: 10.3 ↗

Serie 50.0
Total 186.0

2. Serie 5 Skott

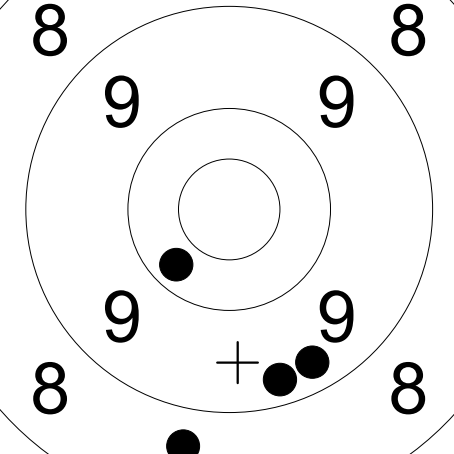

- 1: 8.7 ↓
- 2: 9.3 ↓
- 3: 9.3 ↓
- 4: 10.3 ↘
- 5: 0.0

Serie 36.0
Total 222.0

5 Skott Prov

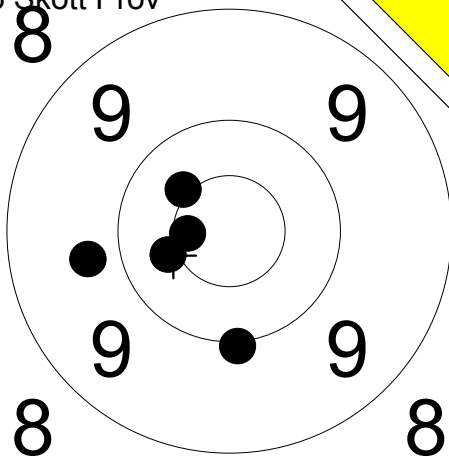

- 1: 9.7 ←
- 2: 10.4 ←
- 3: *10.4 ↗
- 4: *10.6 ←
- 5: 10.0 ↓

Serie 49.0
Total 0.0

1. Serie 5 Skott

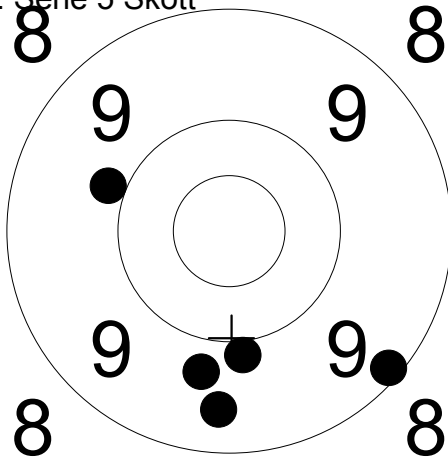

- 1: 9.9 ↖
- 2: 9.1 ↘
- 3: 9.7 ↓
- 4: 9.9 ↓
- 5: 9.4 ↓

Serie 45.0
Total 45.0

2. Serie 5 Skott

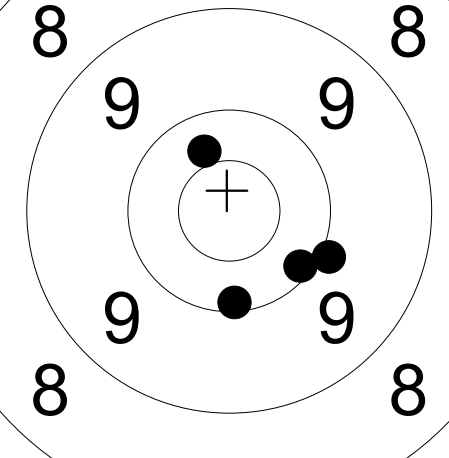

- 1: 8.2 ↗
- 2: 10.1 ↓
- 3: 9.9 ↘
- 4: 10.4 ↗
- 5: 10.1 ↓

Serie 47.0
Total 92.0

6. Serie 5 Skott

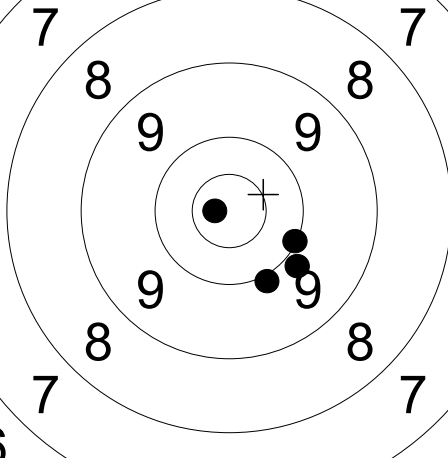

- 1: 7.8 ↑
- 2: 10.0 ↓
- 3: 10.0 ↘
- 4: 9.8 ↘
- 5: *10.8 ←

Serie 46.0
Total 138.0

7. Skott Prov

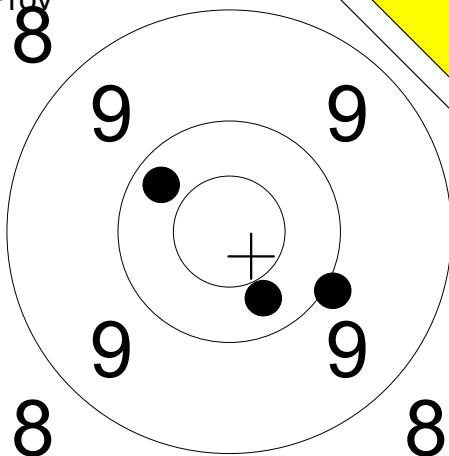

- 1: 10.3 ↖
- 2: 10.3 ↓
- 3: 10.0 ↘

Serie 30.0
Total 138.0

1. Serie 5 Skott

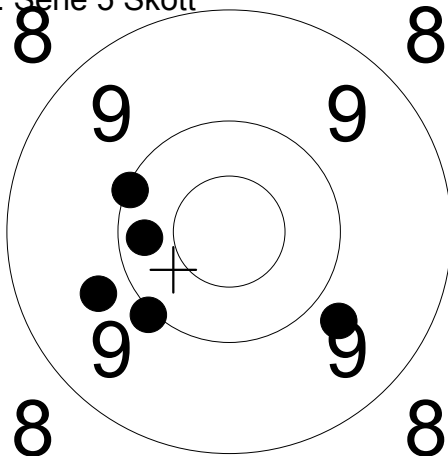

- 1: 10.1 ↖
- 2: 10.0 ↘
- 3: 9.7 ↖
- 4: 10.2 ←
- 5: 9.8 ↘

Serie 48.0
Total 186.0

2. Serie 5 Skott

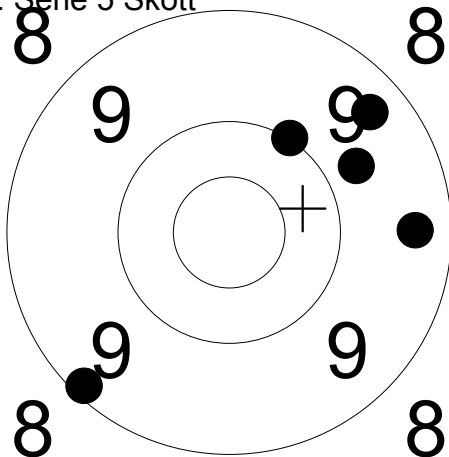

- 1: 10.0 ↗
- 2: 9.4 →
- 3: 9.7 ↗
- 4: 9.4 ↗
- 5: 9.1 ↘

Serie 46.0
Total 232.0

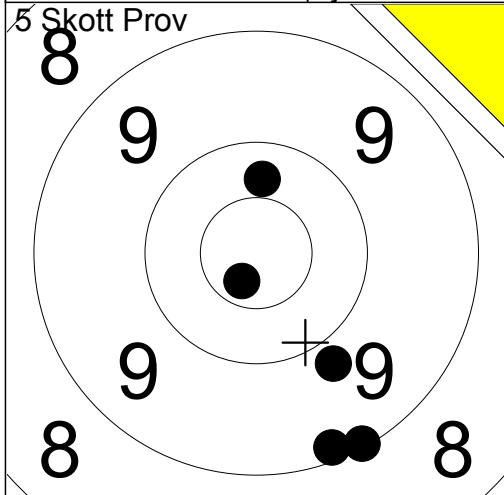

1:	*10.7	↘
2:	9.1	↘
3:	9.2	↘
4:	9.8	↘
5:	10.3	↑
Serie		47.0
Total		0.0

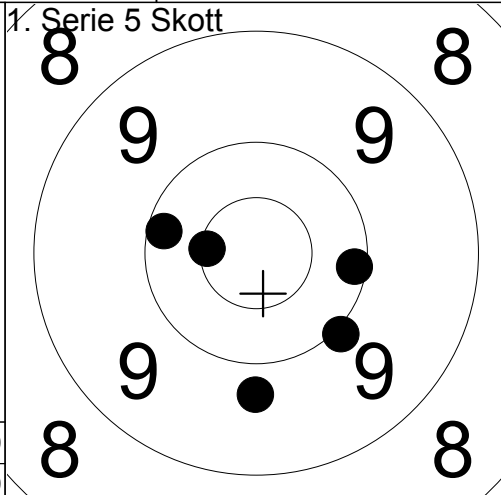

1:	10.2	↖
2:	*10.5	↖
3:	9.8	↘
4:	10.1	→
5:	10.0	↘
Serie		49.0
Total		49.0

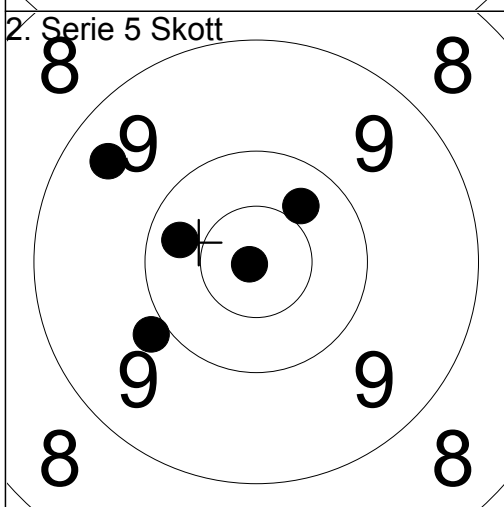

1:	9.4	↖
2:	10.3	↖
3:	*10.9	↖
4:	10.4	↗
5:	9.9	↖
Serie		48.0
Total		97.0

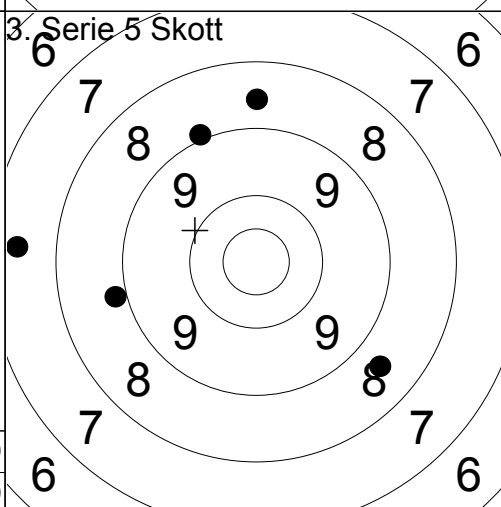

1:	8.9	↗
2:	8.6	↑
3:	8.6	↘
4:	7.4	↖
5:	8.9	↖
Serie		39.0
Total		136.0

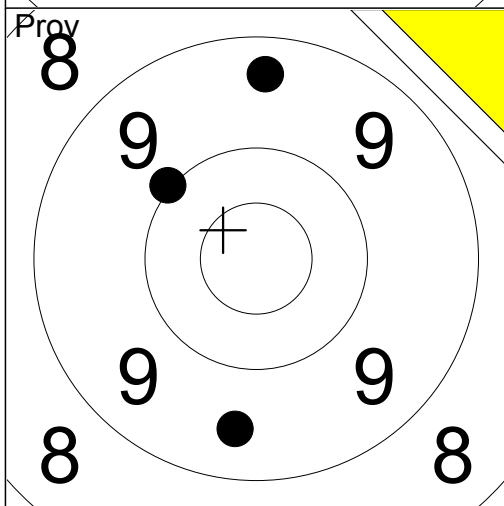

1:	9.4	↑
2:	10.0	↗
3:	9.5	↘
Serie		28.0
Total		136.0

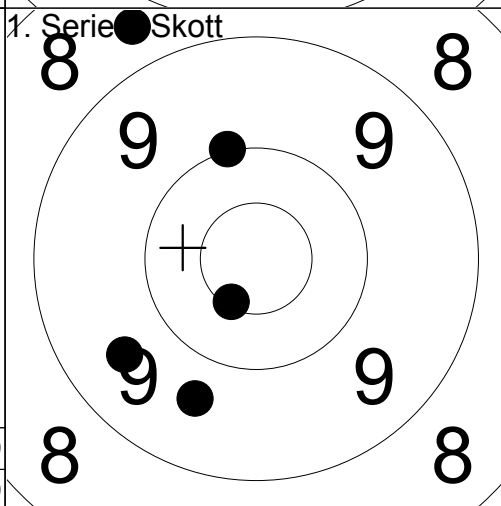

1:	8.7	↖
2:	9.6	↖
3:	*10.5	↘
4:	10.0	↗
5:	9.7	↘
Serie		46.0
Total		182.0

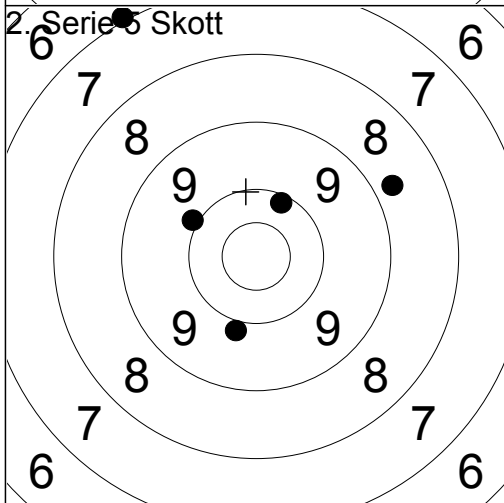

1:	10.1	↗
2:	9.9	↖
3:	9.9	↘
4:	7.0	↗
5:	8.8	↗
Serie		43.0
Total		225.0

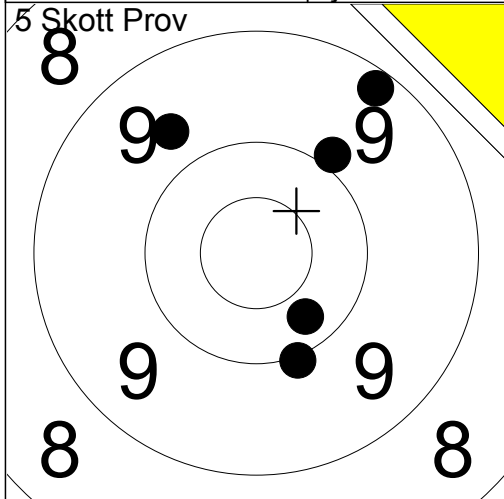

1:	9.2	↗
2:	10.3	↘
3:	10.0	↘
4:	9.9	↗
5:	9.7	↗
Serie	47.0	
Total	0.0	

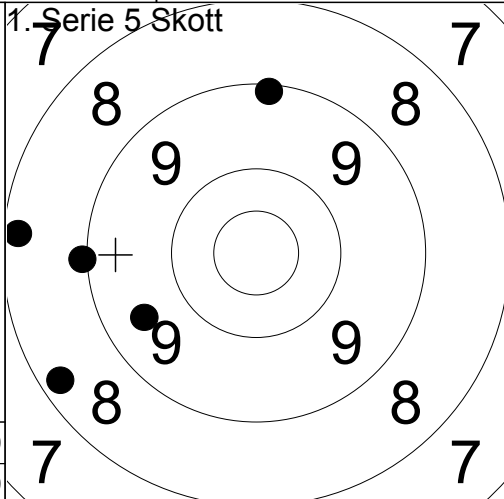

1:	9.1	↑
2:	9.5	↙
3:	8.2	←
4:	8.3	↙
5:	9.0	←
Serie	43.0	
Total	43.0	

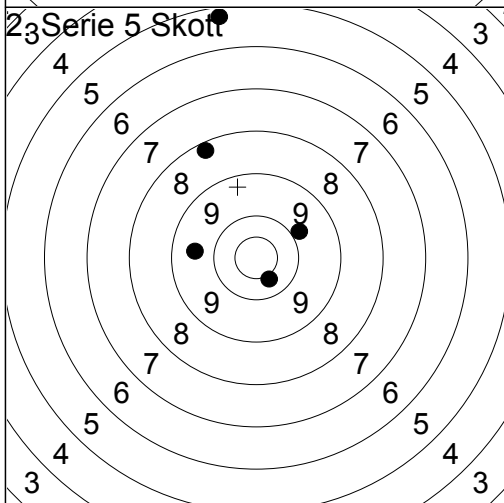

1:	8.2	↗
2:	9.6	←
3:	10.4	↘
4:	9.8	↗
5:	5.3	↑
Serie	41.0	
Total	84.0	

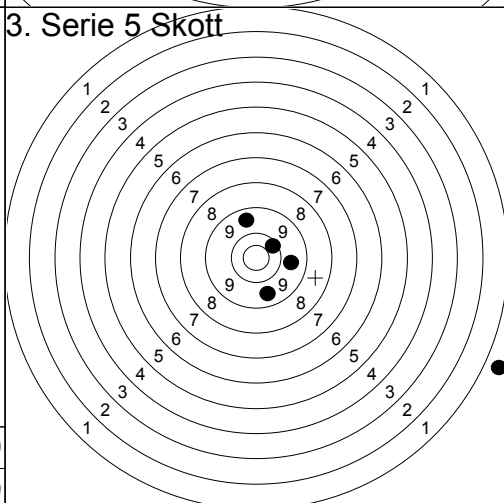

1:	9.6	→
2:	9.5	↘
3:	10.2	↗
4:	0.0	→
5:	9.5	↑
Serie	37.0	
Total	121.0	

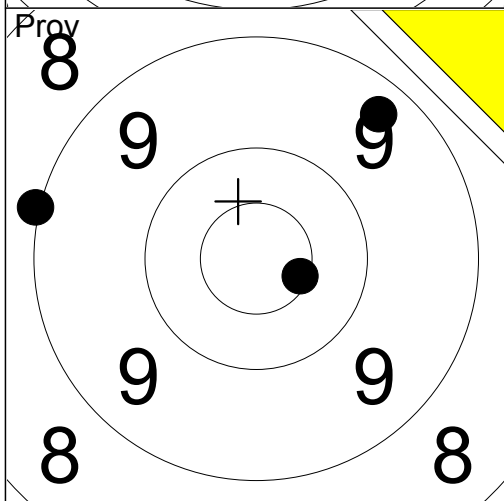

1:	9.3	↗
2:	*10.6	→
3:	9.0	←
Serie	28.0	
Total	121.0	

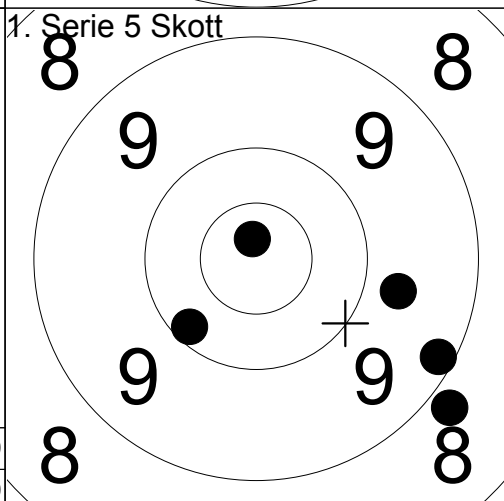

1:	8.8	↘
2:	9.7	→
3:	9.2	↘
4:	*10.8	↑
5:	10.2	↙
Serie	46.0	
Total	167.0	

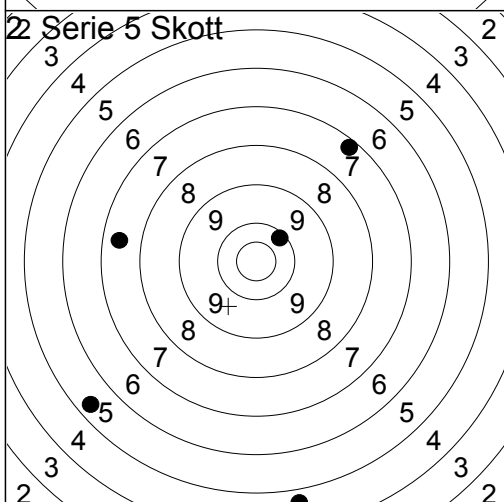

1:	7.2	↗
2:	7.4	←
3:	4.7	↘
4:	10.2	↗
5:	5.4	↙
Serie	33.0	
Total	200.0	

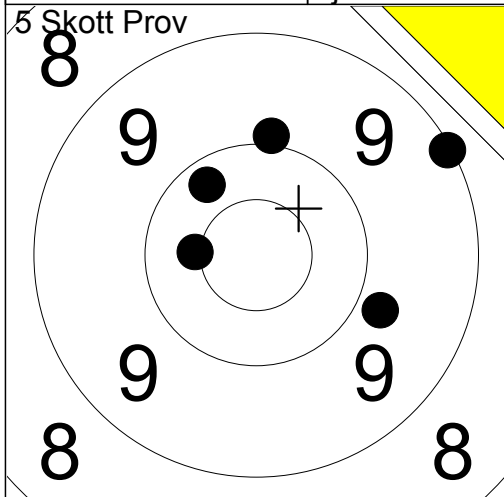

1:	9.9	↑
2:	*10.4	←
3:	10.2	↑
4:	9.1	↗
5:	9.8	↘
Serie	47.0	
Total	0.0	

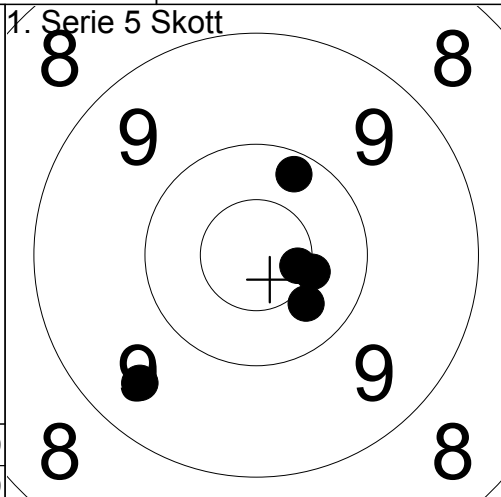

1:	9.5	↙
2:	*10.5	→
3:	*10.6	→
4:	10.4	↘
5:	10.2	↑
Serie	49.0	
Total	49.0	

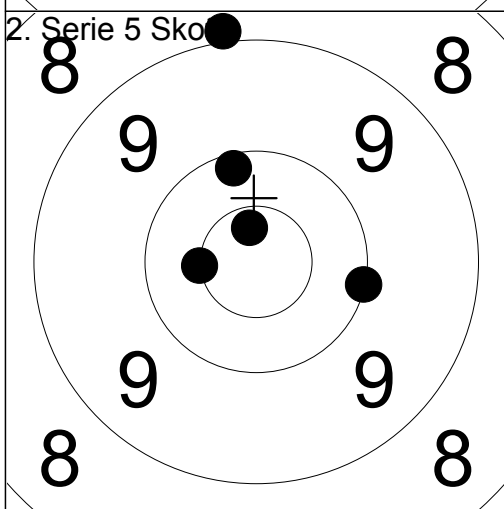

1:	8.9	↑
2:	*10.5	←
3:	10.0	→
4:	*10.7	↑
5:	10.1	↑
Serie	48.0	
Total	97.0	

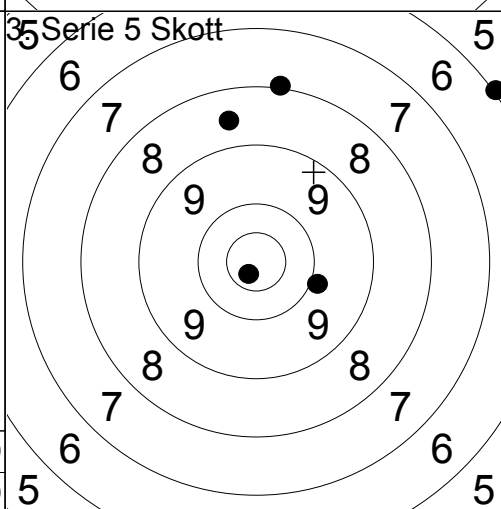

1:	8.0	↑
2:	8.6	↑
3:	9.9	→
4:	*10.7	↙
5:	6.0	↗
Serie	41.0	
Total	138.0	

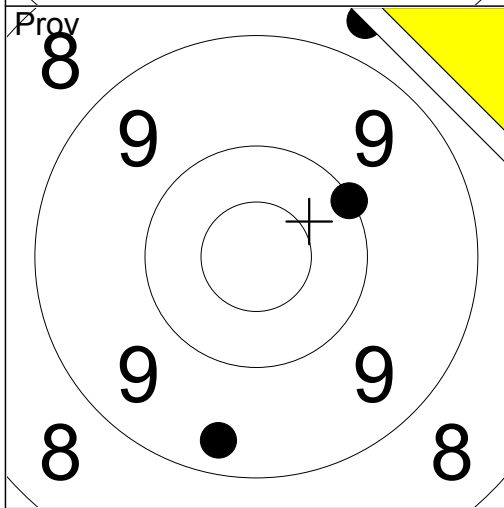

1:	8.7	↑
2:	10.0	↗
3:	9.3	↓
Serie	27.0	
Total	138.0	

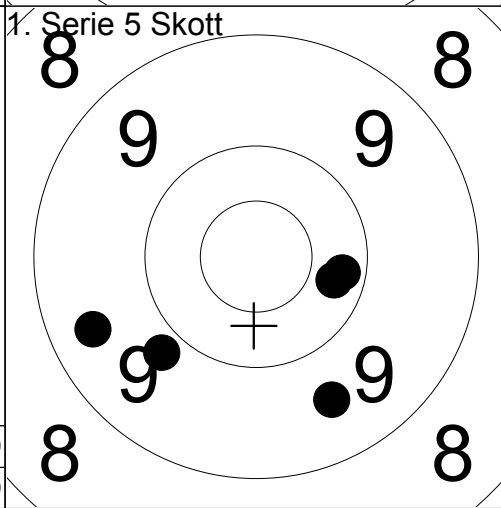

1:	10.2	→
2:	9.8	↙
3:	9.6	↘
4:	10.3	→
5:	9.4	↙
Serie	47.0	
Total	185.0	

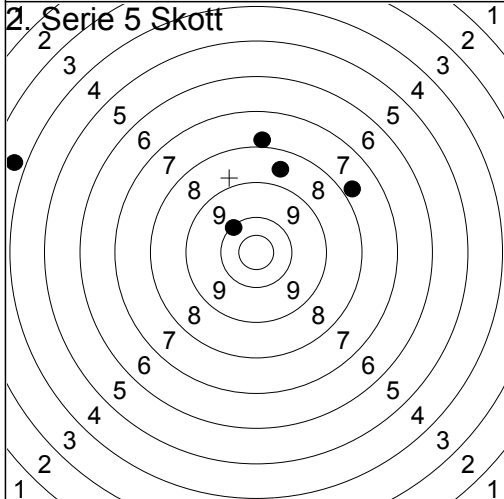

1:	7.8	↑
2:	8.6	↑
3:	10.1	↑
4:	3.7	←
5:	7.8	↗
Serie	35.0	
Total	220.0	

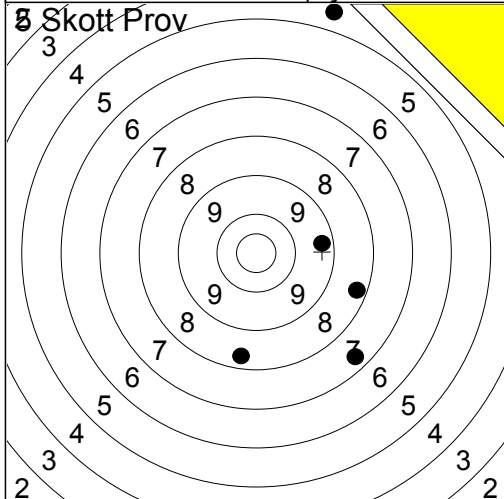

1:	4.5	↗
2:	8.4	↘
3:	7.4	↘
4:	8.3	↘
5:	9.3	→

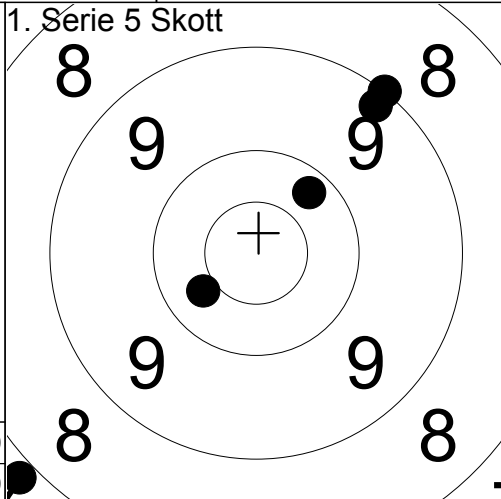

1:	9.0	↗
2:	9.2	↗
3:	10.2	↗
4:	10.4	↖
5:	7.9	↖

Serie	36.0
Total	0.0

Serie	45.0
Total	45.0

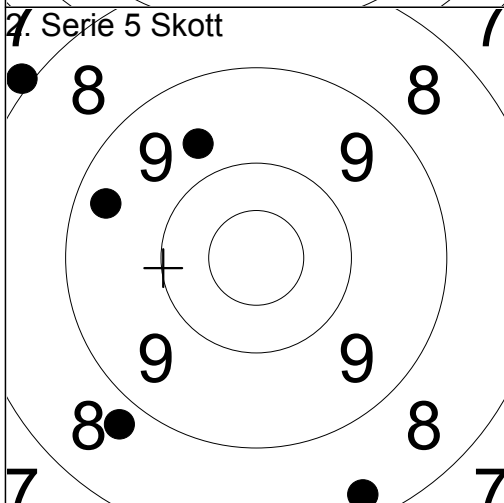

1:	7.9	↗
2:	9.3	↗
3:	9.7	↗
4:	8.8	↘
5:	8.3	↘

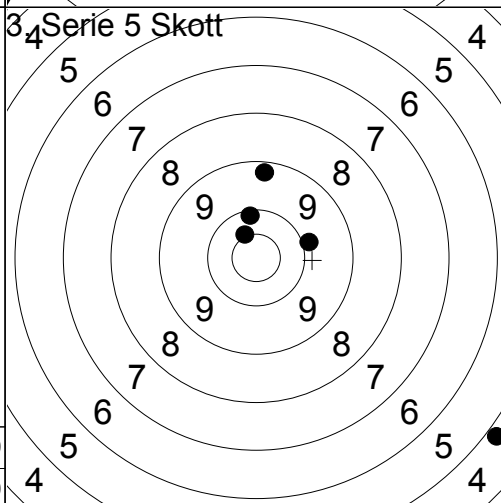

1:	*10.5	↗
2:	9.2	↑
3:	9.9	→
4:	10.1	↑
5:	4.8	↘

Serie	41.0
Total	86.0

Serie	42.0
Total	128.0

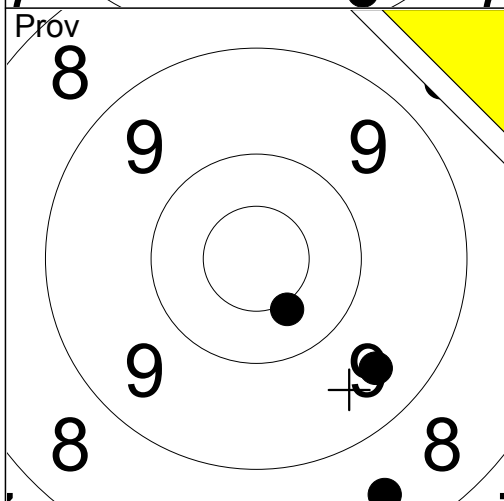

1:	*10.4	↘
2:	8.5	↘
3:	9.5	↘

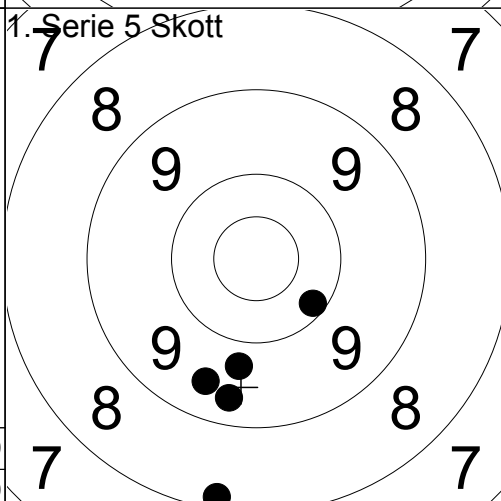

1:	10.2	↘
2:	9.7	↘
3:	9.5	↘
4:	8.2	↘
5:	9.4	↘

Serie	27.0
Total	128.0

Serie	45.0
Total	173.0

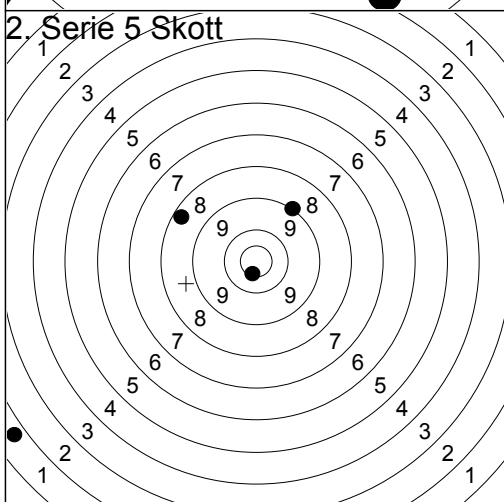

1:	8.3	↖
2:	*10.6	↘
3:	9.0	↗
4:	1.7	↖
5:	0.0	

Serie	28.0
Total	201.0

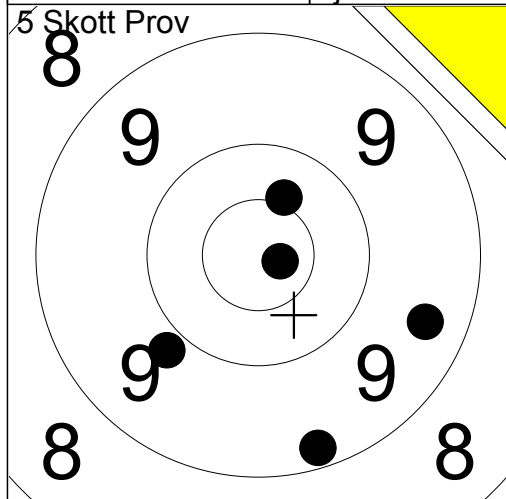

1:	*10.8	→
2:	9.8	↙
3:	*10.4	↗
4:	9.2	↘
5:	9.4	→
Serie		47.0
Total		0.0

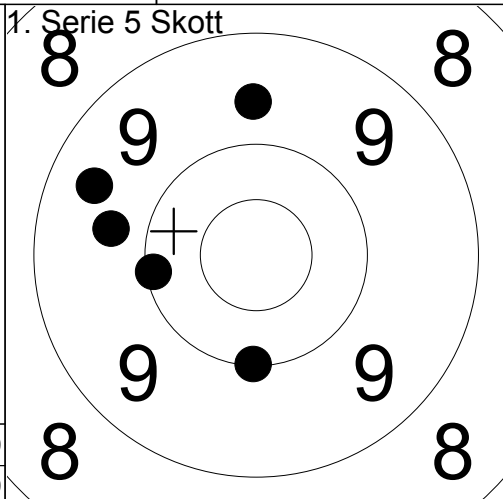

1:	10.1	←
2:	9.7	↑
3:	9.4	↙
4:	9.7	↖
5:	10.0	↓
Serie		47.0
Total		47.0

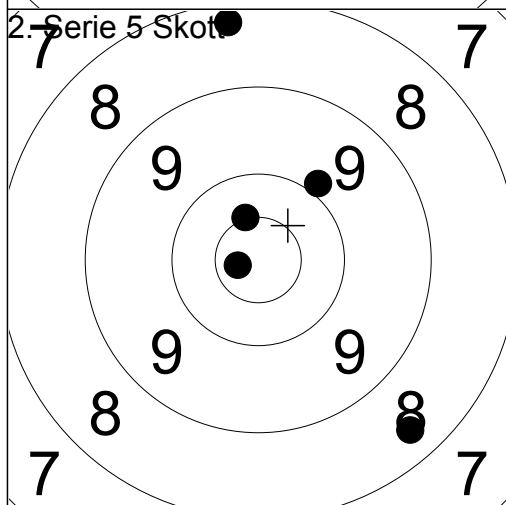

1:	9.9	↗
2:	*10.7	←
3:	8.3	↑
4:	*10.5	↗
5:	8.4	↘
Serie		45.0
Total		92.0

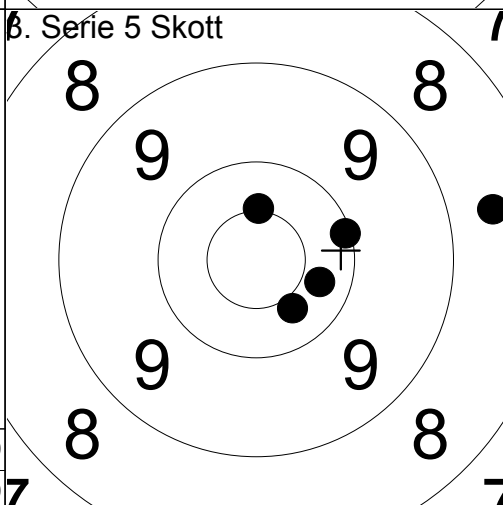

1:	10.1	→
2:	10.3	→
3:	*10.5	↑
4:	10.4	↘
5:	8.6	→
Serie		48.0
Total		140.0

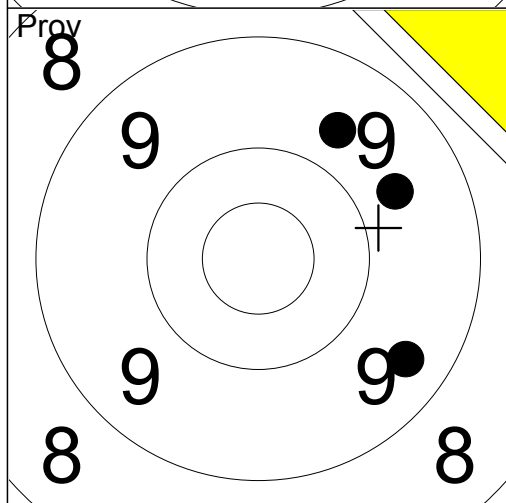

1:	9.7	↗
2:	9.7	→
3:	9.4	↘
Serie		27.0
Total		140.0

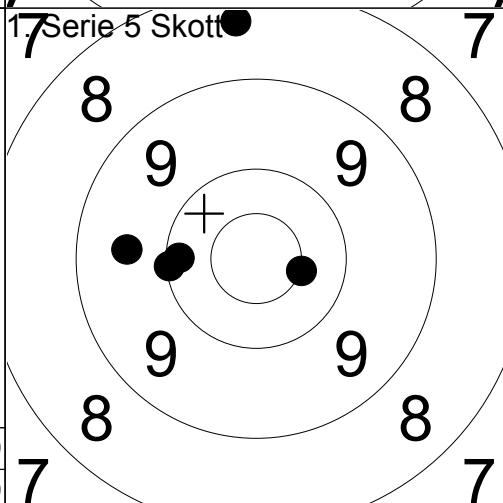

1:	10.1	←
2:	9.6	←
3:	10.2	←
4:	8.4	↑
5:	*10.5	→
Serie		47.0
Total		187.0

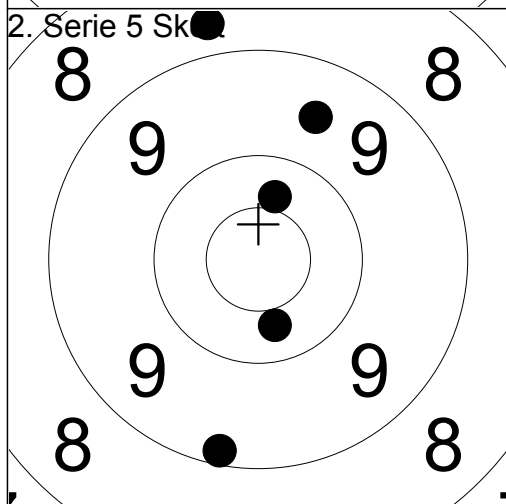

1:	10.4	↑
2:	10.4	↓
3:	9.6	↗
4:	8.7	↑
5:	9.2	↓
Serie		46.0
Total		233.0

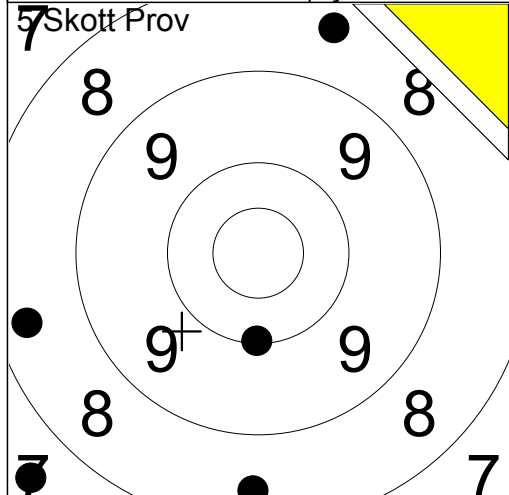

1:	8.4	←
2:	7.5	↙
3:	8.4	↓
4:	10.1	↓
5:	8.4	↑
Serie	41.0	
Total	0.0	

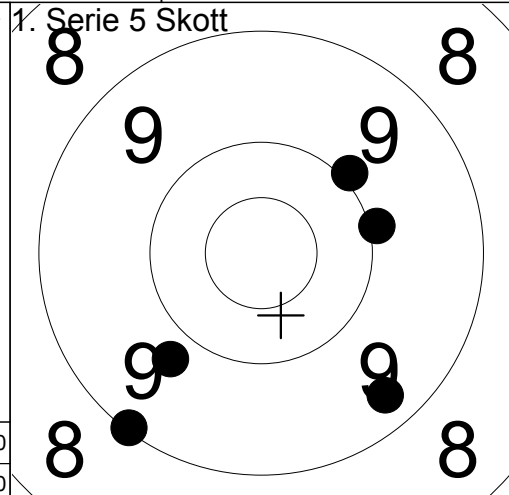

1:	9.8	↘
2:	10.0	↗
3:	9.3	↘
4:	10.0	→
5:	9.1	↘
Serie	47.0	
Total	47.0	

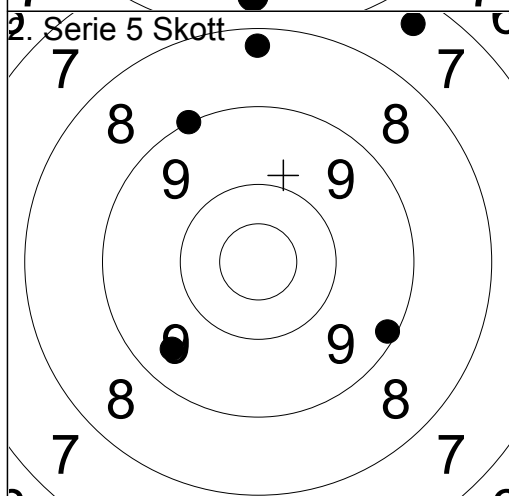

1:	7.4	↗
2:	9.0	↗
3:	8.2	↑
4:	9.1	↘
5:	9.5	↘
Serie	42.0	
Total	89.0	

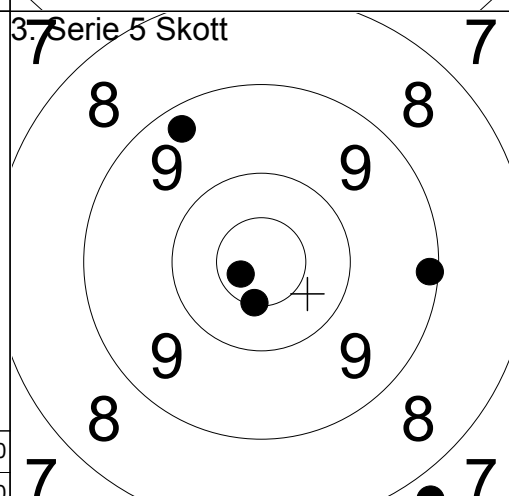

1:	7.7	↘
2:	9.1	→
3:	9.3	↗
4:	*10.7	↙
5:	*10.5	↘
Serie	45.0	
Total	134.0	

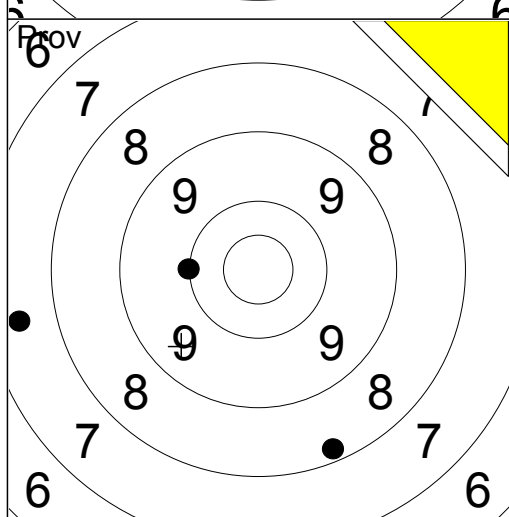

1:	7.5	←
2:	8.2	↘
3:	10.0	←
Serie	25.0	
Total	134.0	

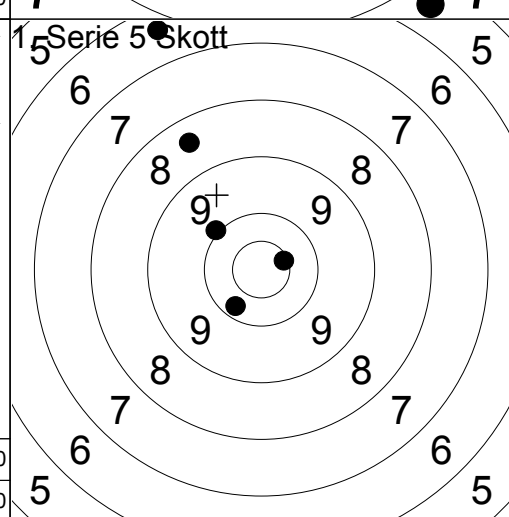

1:	*10.5	↗
2:	8.5	↗
3:	6.4	↗
4:	10.2	↘
5:	10.0	↗
Serie	44.0	
Total	178.0	

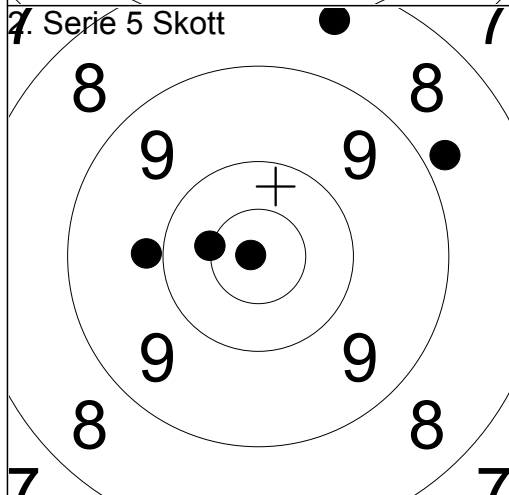

1:	8.8	↗
2:	8.4	↑
3:	9.9	←
4:	*10.9	←
5:	*10.5	←
Serie	45.0	
Total	223.0	

5 Skott Prov

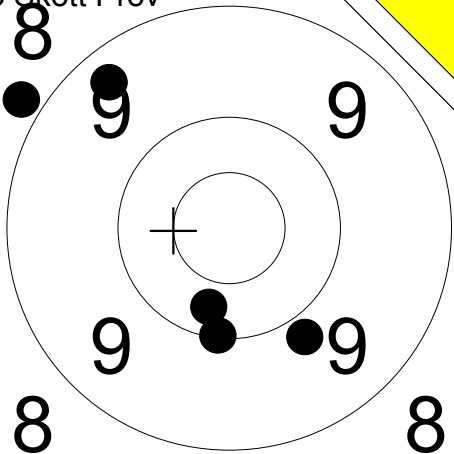

- 1: 8.8 ↗
- 2: 10.0 ↓
- 3: 9.3 ↗
- 4: 9.8 ↓
- 5: 10.3 ↓

Serie 46.0
Total 0.0

1. Serie 5 Skott

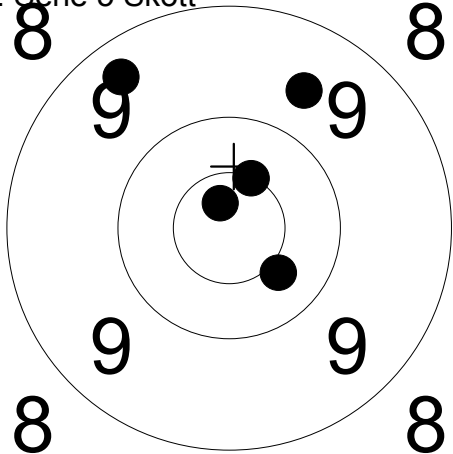

- 1: *10.7 ↗
- 2: *10.5 ↗
- 3: 9.4 ↗
- 4: 9.6 ↗
- 5: 10.4 ↓

Serie 48.0
Total 48.0

2. Serie 5 Skott

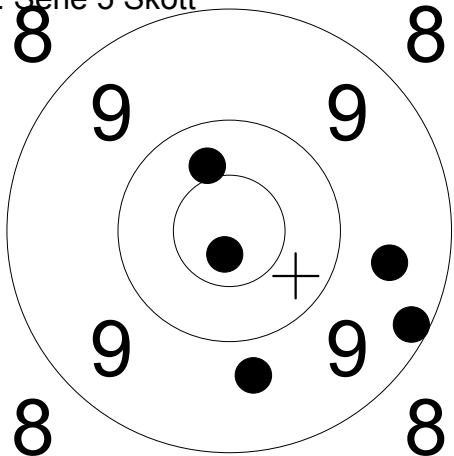

- 1: 9.7 ↓
- 2: 10.4 ↗
- 3: *10.8 ↓
- 4: 9.2 ↘
- 5: 9.6 ↘

Serie 47.0
Total 95.0

3. Serie 5 Skott

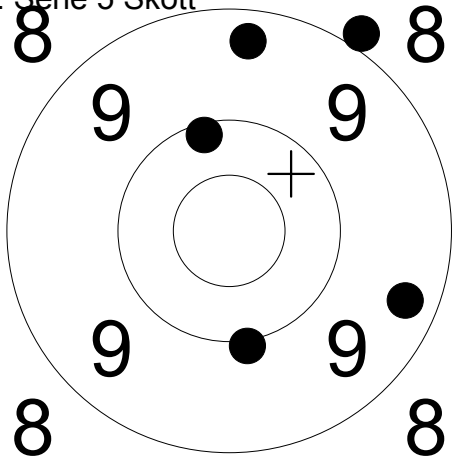

- 1: 9.3 ↗
- 2: 8.9 ↗
- 3: 9.3 ↘
- 4: 10.1 ↗
- 5: 10.0 ↓

Serie 46.0
Total 141.0

Prov

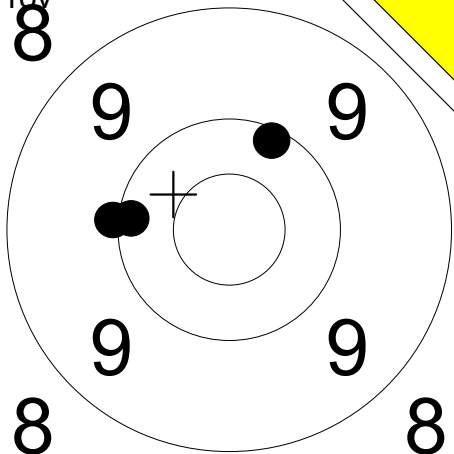

- 1: 10.0 ←
- 2: 10.1 ←
- 3: 10.1 ↗

Serie 30.0
Total 141.0

1. Serie 5 Skott

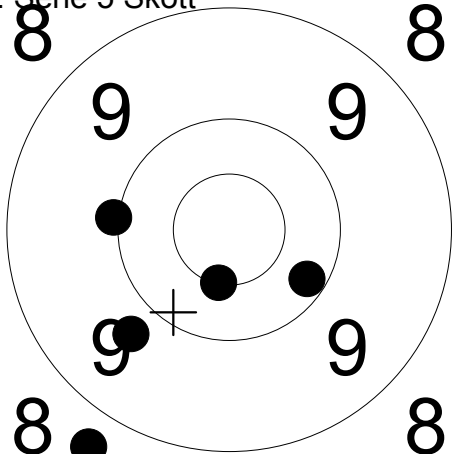

- 1: 9.7 ↘
- 2: *10.5 ↓
- 3: 10.2 ↘
- 4: 8.7 ↘
- 5: 10.0 ←

Serie 47.0
Total 188.0

2. Serie 5 Skott

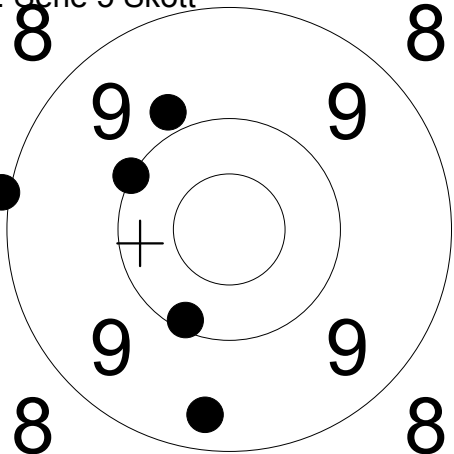

- 1: 9.0 ←
- 2: 9.8 ↗
- 3: 10.1 ↓
- 4: 10.0 ↗
- 5: 9.4 ↓

Serie 47.0
Total 235.0

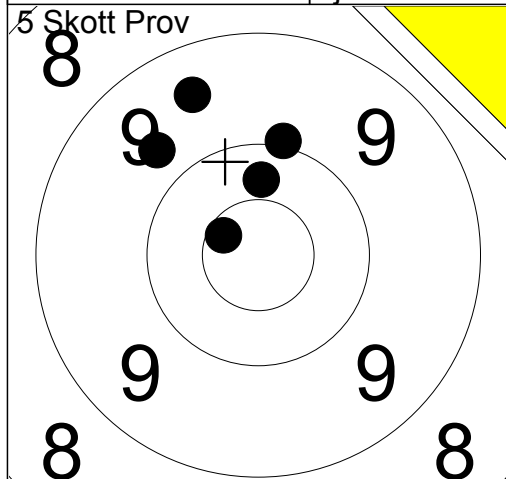

- 1: 9.5 ↗
- 2: 9.7 ↗
- 3: *10.6 ↗
- 4: 10.0 ↗
- 5: 10.3 ↗

Serie 48.0
Total 0.0

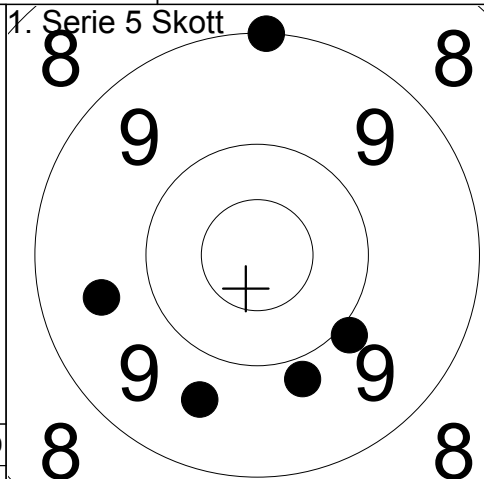

- 1: 9.0 ↗
- 2: 9.6 ←
- 3: 9.9 ↘
- 4: 9.8 ↘
- 5: 9.6 ↘

Serie 45.0
Total 45.0

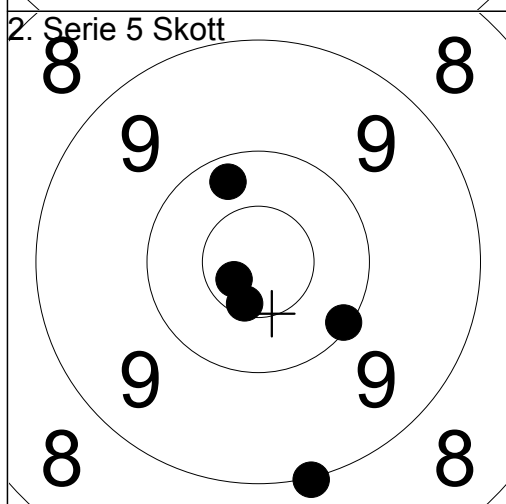

- 1: 9.0 ↘
- 2: *10.7 ↘
- 3: 10.2 ↗
- 4: 10.1 ↘
- 5: *10.6 ↘

Serie 49.0
Total 94.0

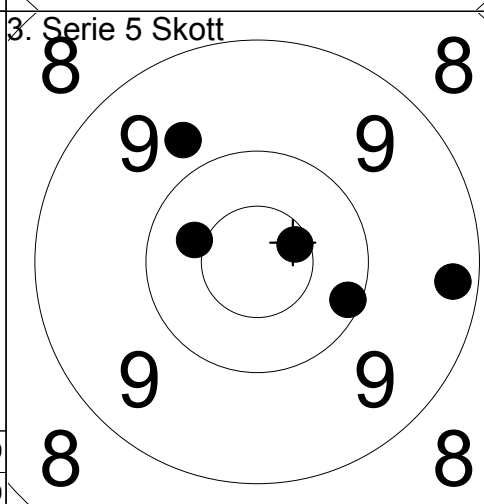

- 1: *10.6 ↗
- 2: 10.4 ↗
- 3: 9.7 ↗
- 4: 9.3 →
- 5: 10.1 ↘

Serie 48.0
Total 142.0

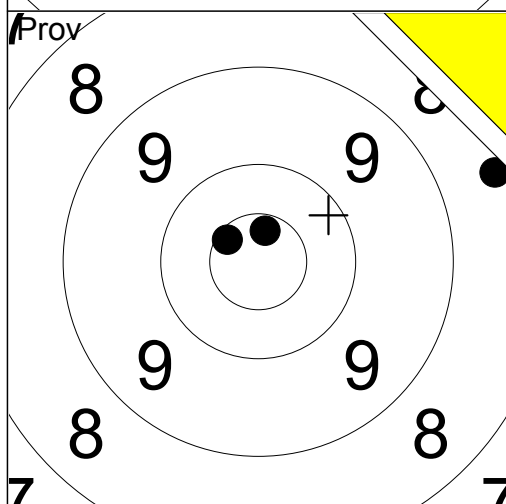

- 1: 8.4 →
- 2: *10.6 ↗
- 3: *10.6 ↗

Serie 28.0
Total 142.0

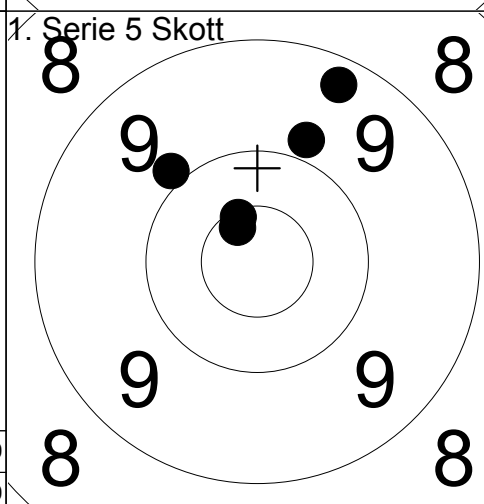

- 1: 9.3 ↗
- 2: 9.9 ↗
- 3: *10.5 ↗
- 4: 9.9 ↗
- 5: *10.6 ↗

Serie 47.0
Total 189.0

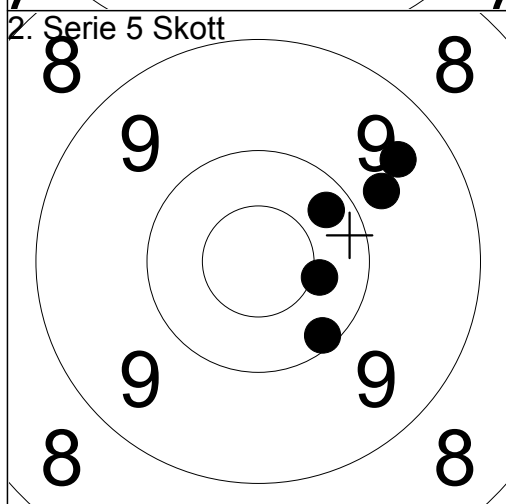

- 1: 10.2 ↗
- 2: 9.5 ↗
- 3: 10.1 ↘
- 4: *10.4 ↘
- 5: 9.8 ↗

Serie 48.0
Total 237.0

5 Skott Prov

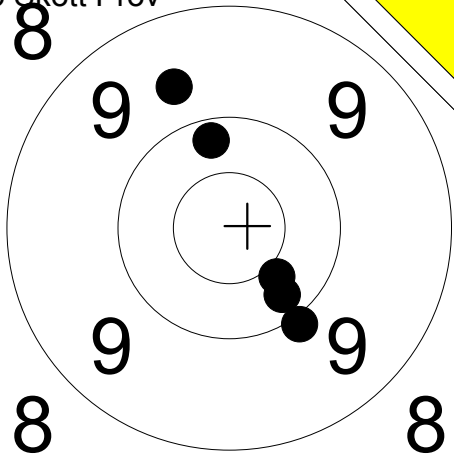

- 1: 10.2 ↗
- 2: 10.4 ↘
- 3: 10.2 ↘
- 4: 9.7 ↗
- 5: 10.0 ↘

Serie 49.0
Total 0.0

1. Serie 5 Skott

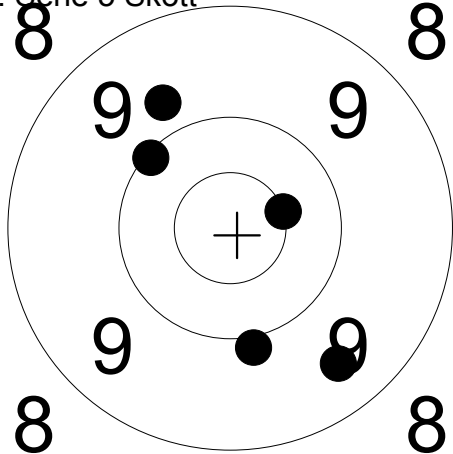

- 1: *10.5 →
- 2: 9.7 ↗
- 3: 10.1 ↗
- 4: 9.5 ↘
- 5: 9.9 ↘

Serie 47.0
Total 47.0

2. Serie 5 Skott

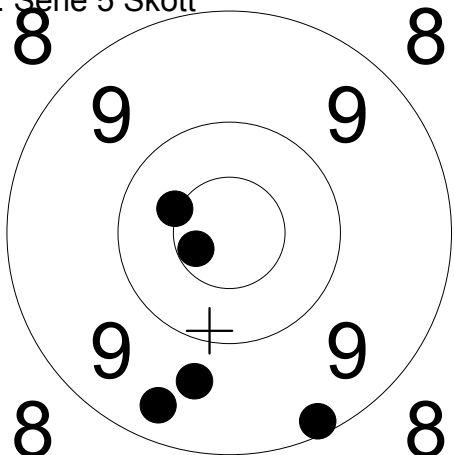

- 1: *10.5 ←
- 2: 9.2 ↘
- 3: *10.6 ←
- 4: 9.4 ↘
- 5: 9.7 ↘

Serie 47.0
Total 94.0

3. Serie 5 Skott

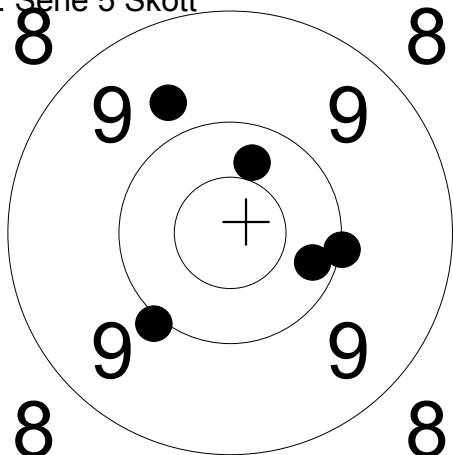

- 1: 10.0 ↘
- 2: 10.2 →
- 3: 10.3 ↗
- 4: 10.0 →
- 5: 9.7 ↗

Serie 49.0
Total 143.0

Prov

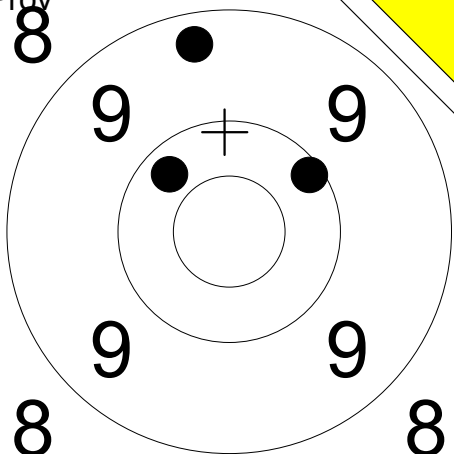

- 1: 9.3 ↗
- 2: 10.1 ↗
- 3: 10.3 ↗

Serie 29.0
Total 143.0

1. Serie 5 Skott

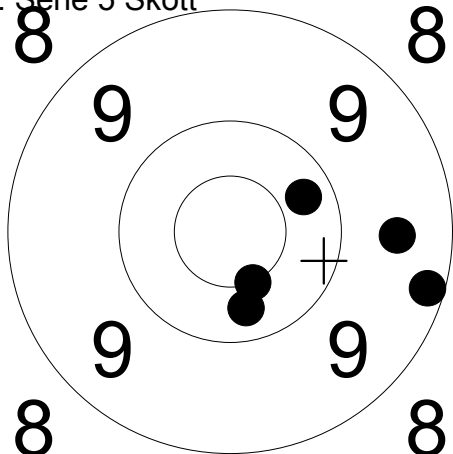

- 1: 9.2 →
- 2: *10.5 ↘
- 3: 10.3 →
- 4: 9.5 →
- 5: 10.3 ↘

Serie 48.0
Total 191.0

2. Serie 5 Skott

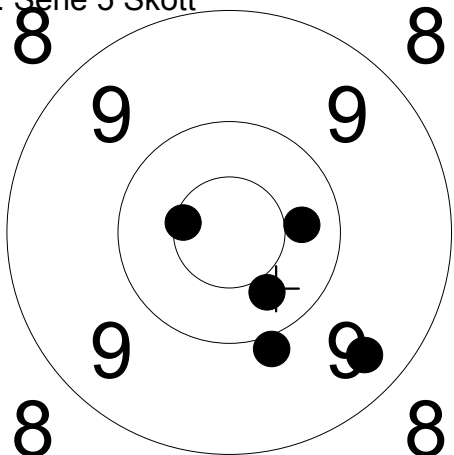

- 1: 10.3 →
- 2: *10.6 ←
- 3: 9.4 ↘
- 4: 10.4 ↘
- 5: 9.9 ↘

Serie 48.0
Total 239.0

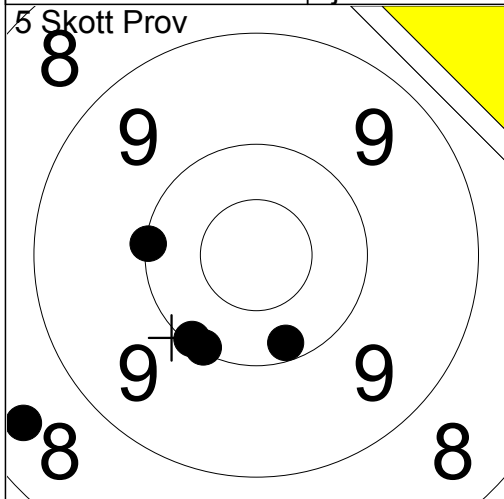

1:	10.0	←
2:	10.1	↘
3:	8.5	↘
4:	10.2	↘
5:	10.1	↘
Serie	48.0	
Total	0.0	

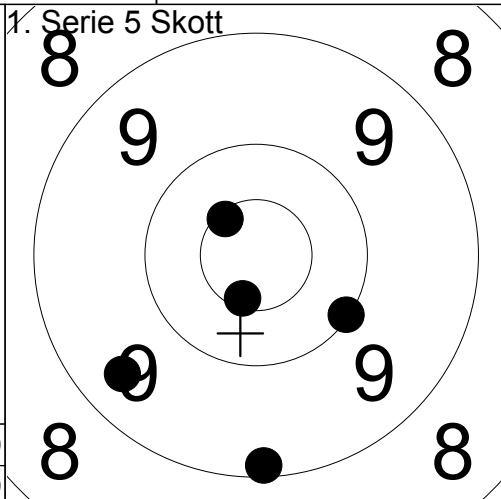

1:	*10.6	↘
2:	9.4	↘
3:	*10.6	↗
4:	10.1	↘
5:	9.1	↘
Serie	48.0	
Total	48.0	

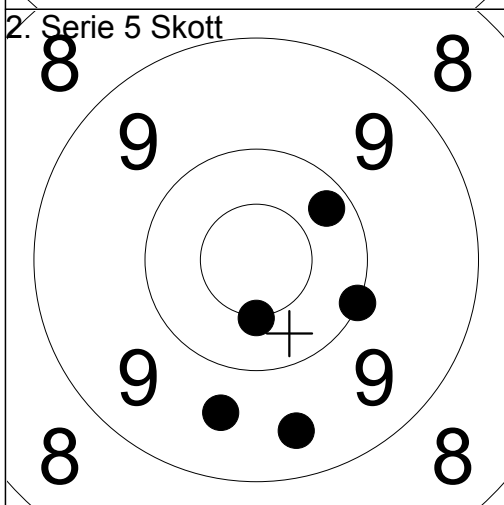

1:	10.2	↗
2:	*10.5	↘
3:	10.0	→
4:	9.6	↘
5:	9.5	↘
Serie	48.0	
Total	96.0	

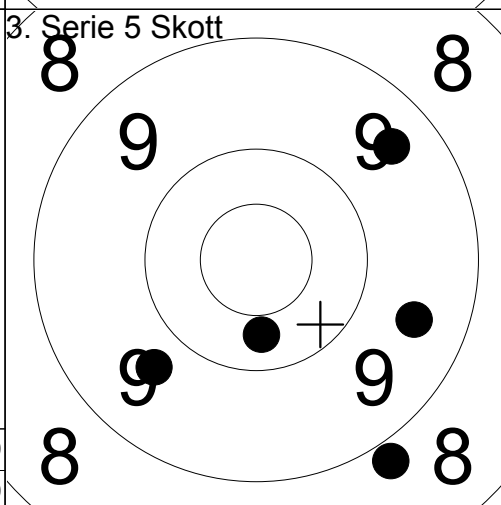

1:	9.4	↗
2:	10.3	↘
3:	9.5	→
4:	9.7	↘
5:	8.9	↘
Serie	45.0	
Total	141.0	

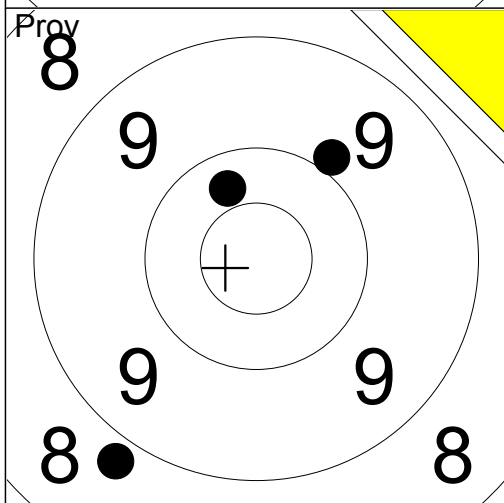

1:	9.9	↗
2:	10.3	↗
3:	8.8	↘
Serie	27.0	
Total	141.0	

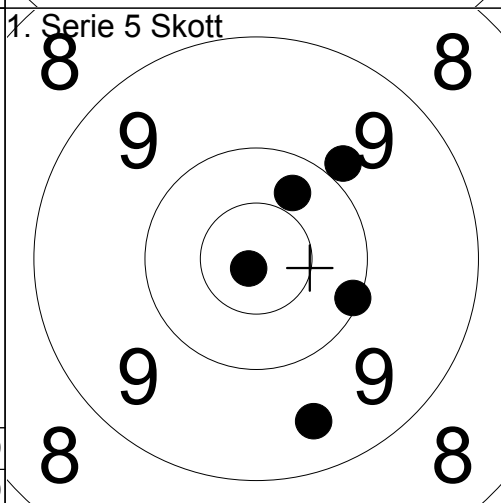

1:	*10.8	↘
2:	10.3	↗
3:	9.9	↗
4:	10.1	→
5:	9.5	↘
Serie	48.0	
Total	189.0	

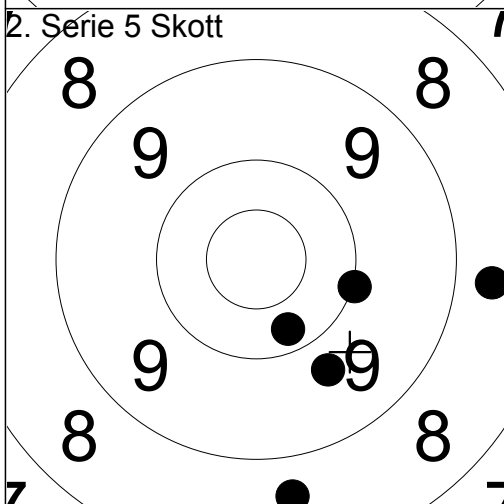

1:	8.7	→
2:	10.0	→
3:	10.2	↘
4:	9.7	↘
5:	8.6	↘
Serie	45.0	
Total	234.0	

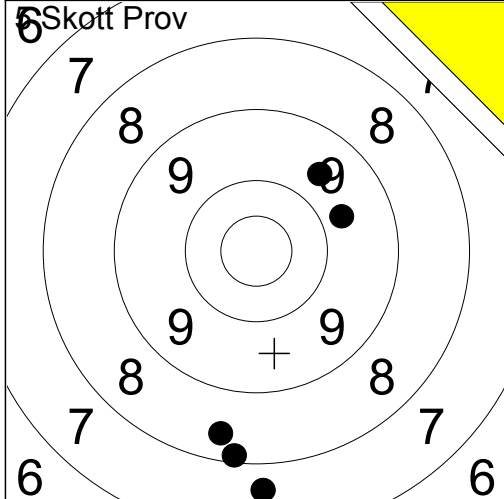

1:	9.6	↗
2:	9.7	→
3:	8.4	↓
4:	7.7	↓
5:	8.1	↓
Serie	41.0	
Total	0.0	

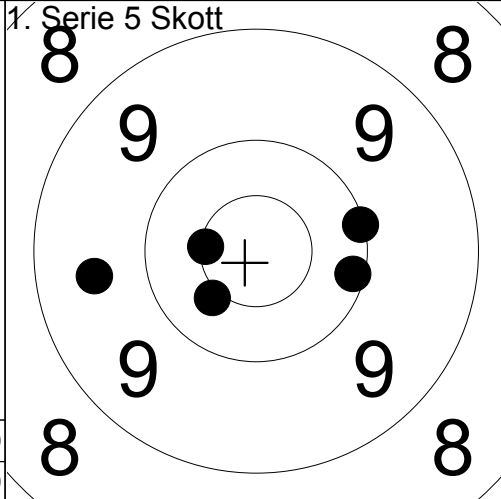

1:	10.1	→
2:	*10.4	↙
3:	*10.5	←
4:	9.6	←
5:	10.1	→
Serie	49.0	
Total	49.0	

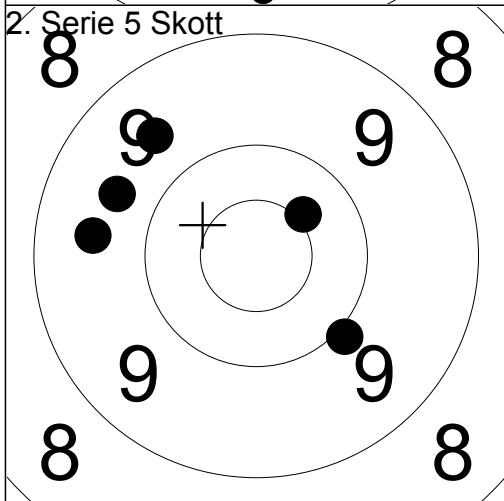

1:	10.0	↘
2:	9.5	←
3:	9.7	↖
4:	9.6	↗
5:	*10.4	↗
Serie	47.0	
Total	96.0	

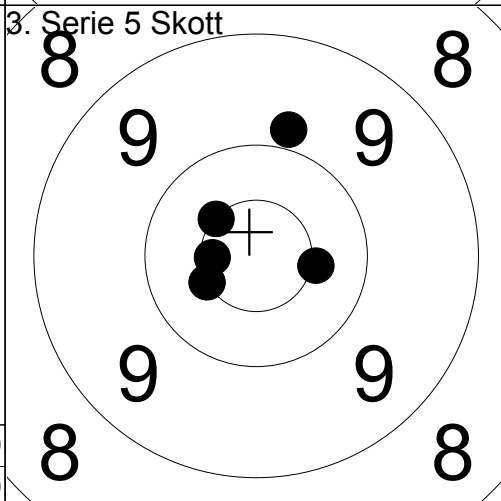

1:	9.9	↑
2:	*10.5	↙
3:	*10.6	←
4:	*10.5	↗
5:	*10.4	→
Serie	49.0	
Total	145.0	

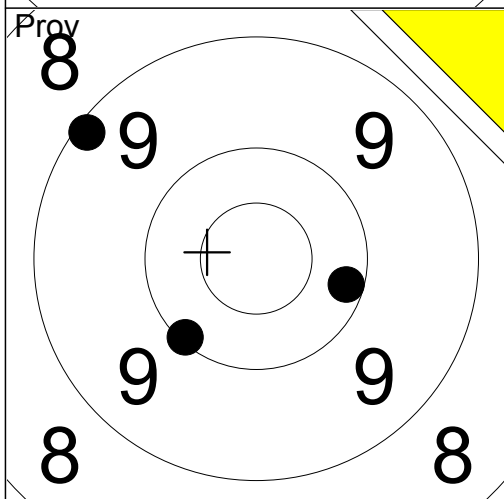

1:	10.2	→
2:	10.1	↙
3:	9.1	↗
Serie	29.0	
Total	145.0	

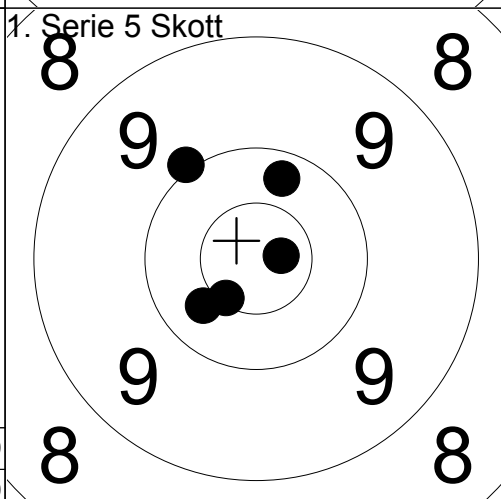

1:	*10.5	↙
2:	*10.7	→
3:	10.3	↑
4:	10.4	↙
5:	10.0	↗
Serie	50.0	
Total	195.0	

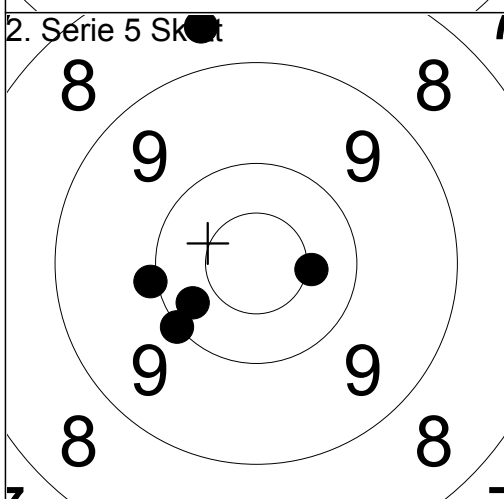

1:	10.0	←
2:	10.3	↙
3:	*10.4	→
4:	8.6	↑
5:	10.0	↙
Serie	48.0	
Total	243.0	

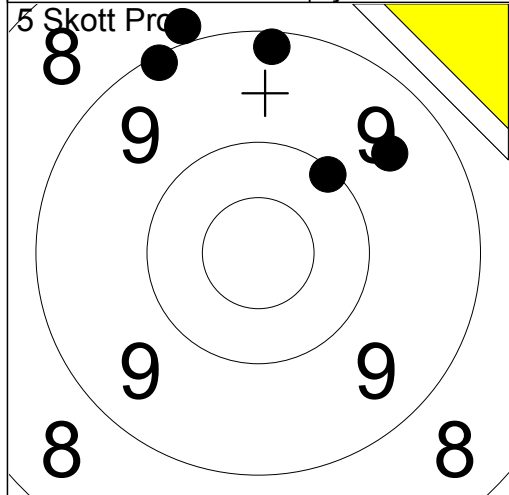

1:	9.2	↑
2:	10.1	↗
3:	9.5	↗
4:	9.1	↗
5:	8.9	↑
Serie	45.0	
Total	0.0	

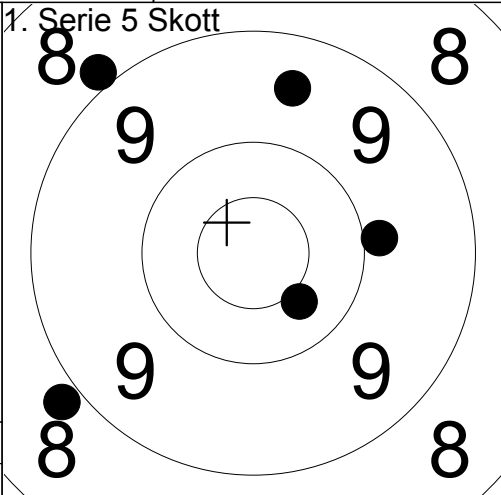

1:	8.9	↙
2:	10.4	↘
3:	9.5	↑
4:	8.9	↗
5:	9.9	→
Serie	44.0	
Total	44.0	

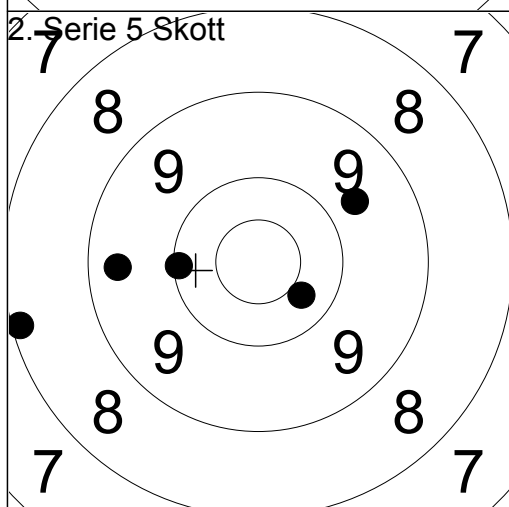

1:	8.1	←
2:	9.4	←
3:	10.1	←
4:	10.4	↘
5:	9.7	↗
Serie	46.0	
Total	90.0	

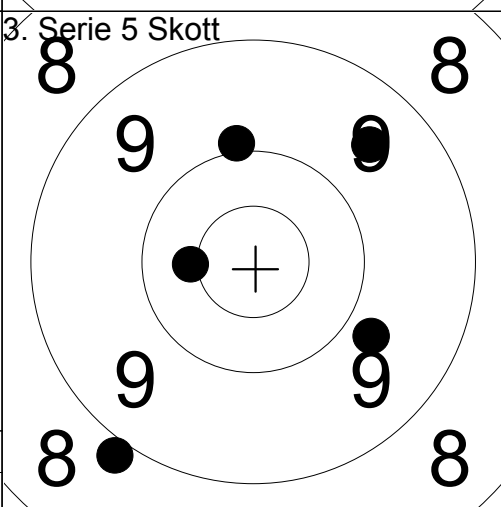

1:	9.5	↗
2:	10.0	↑
3:	8.9	↙
4:	*10.4	←
5:	9.8	↘
Serie	46.0	
Total	136.0	

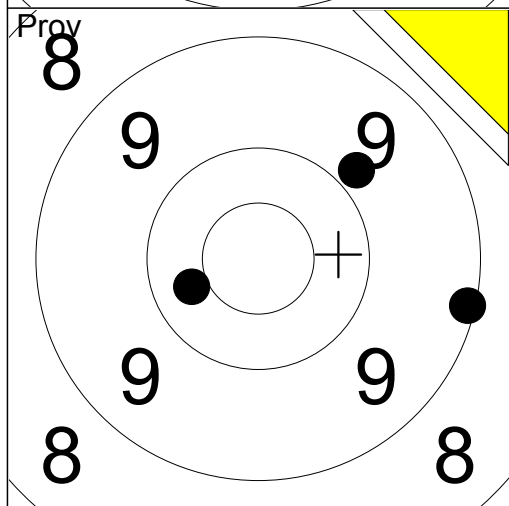

1:	10.3	←
2:	9.1	→
3:	9.8	↗
Serie	28.0	
Total	136.0	

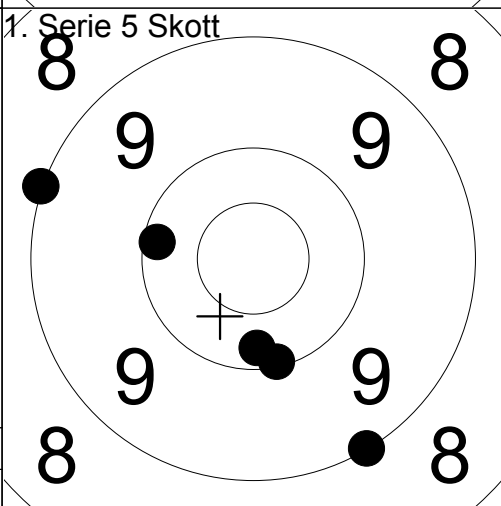

1:	10.2	↓
2:	9.0	↘
3:	9.0	↗
4:	10.1	←
5:	10.1	↓
Serie	48.0	
Total	184.0	

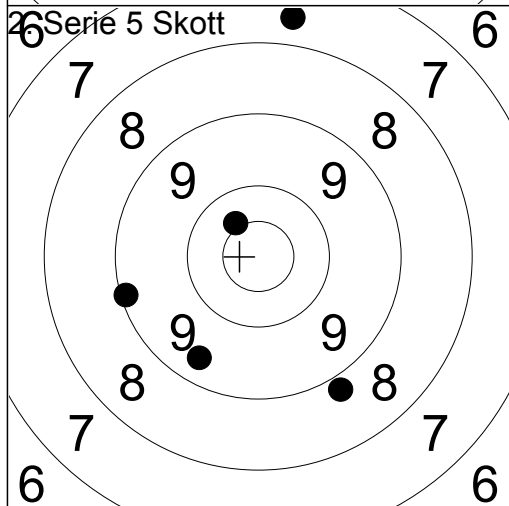

1:	7.6	↑
2:	9.1	←
3:	9.4	↙
4:	*10.4	↗
5:	8.8	↘
Serie	43.0	
Total	227.0	

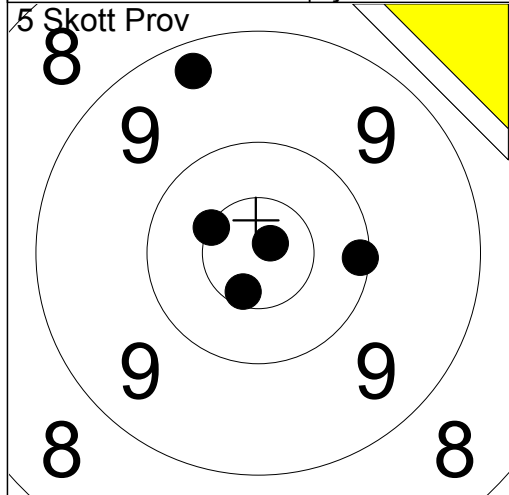

1:	9.3	↗
2:	10.1	→
3:	*10.8	↗
4:	*10.5	↖
5:	*10.6	↘
Serie		49.0
Total		0.0

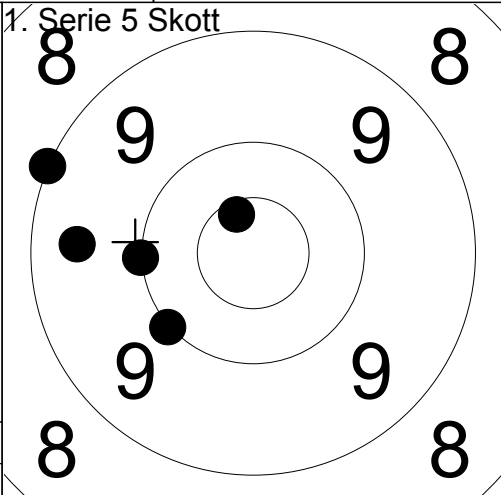

1:	9.0	↖
2:	10.0	←
3:	9.4	←
4:	*10.6	↗
5:	10.0	↘
Serie		48.0
Total		48.0

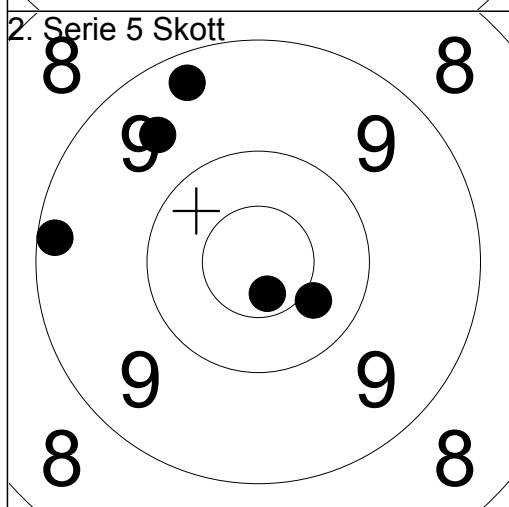

1:	9.6	↗
2:	9.3	↗
3:	*10.7	↘
4:	9.2	←
5:	10.4	↘
Serie		47.0
Total		95.0

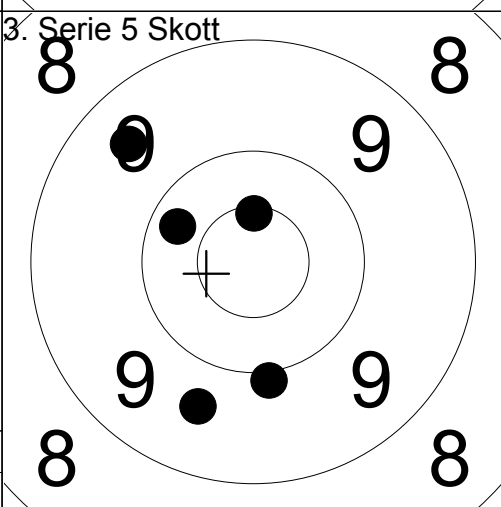

1:	9.5	↖
2:	9.6	↘
3:	*10.5	↗
4:	10.3	↖
5:	10.0	↘
Serie		48.0
Total		143.0

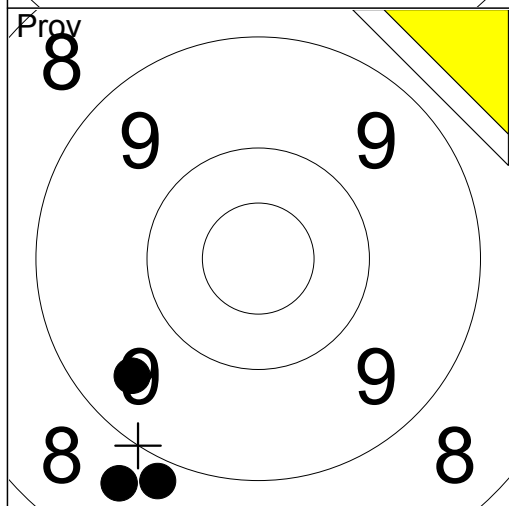

1:	8.7	↘
2:	8.8	↘
3:	9.5	↘
Serie		25.0
Total		143.0

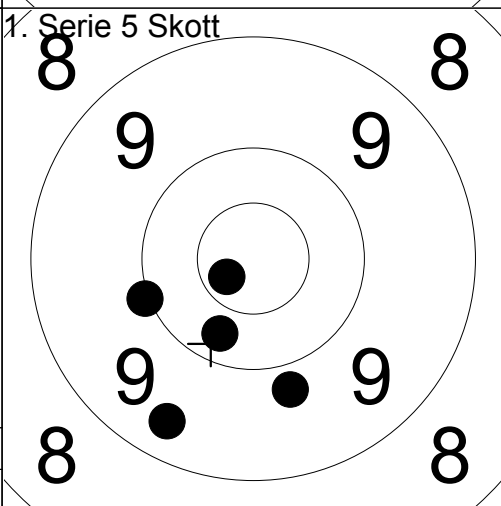

1:	10.3	↘
2:	9.4	↘
3:	9.8	↘
4:	10.0	←
5:	*10.7	↖
Serie		48.0
Total		191.0

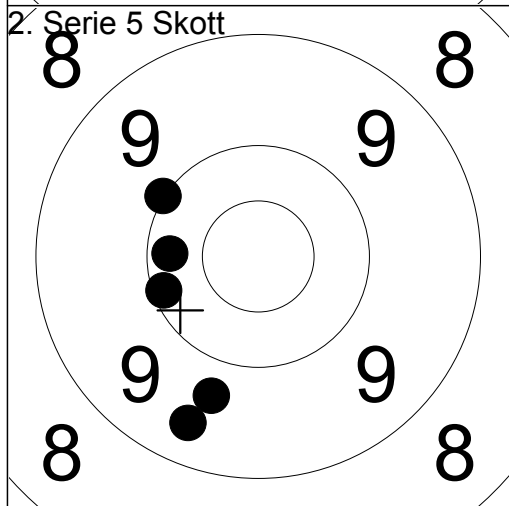

1:	10.2	←
2:	10.0	↖
3:	9.4	↘
4:	9.7	↘
5:	10.1	←
Serie		48.0
Total		239.0

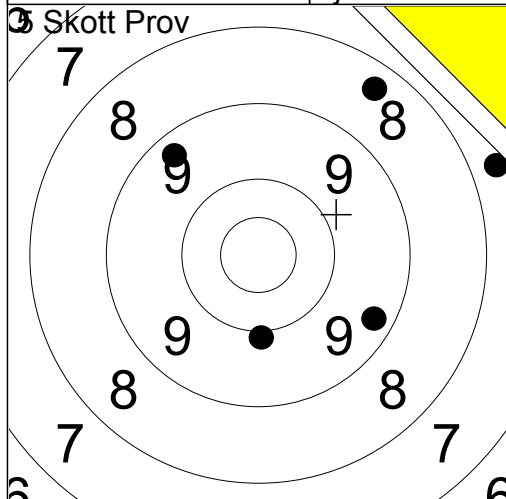

- 1: 9.3 ↗
- 2: 9.9 ↓
- 3: 7.7 →
- 4: 9.3 ↘
- 5: 8.4 ↗

Serie	42.0
Total	0.0

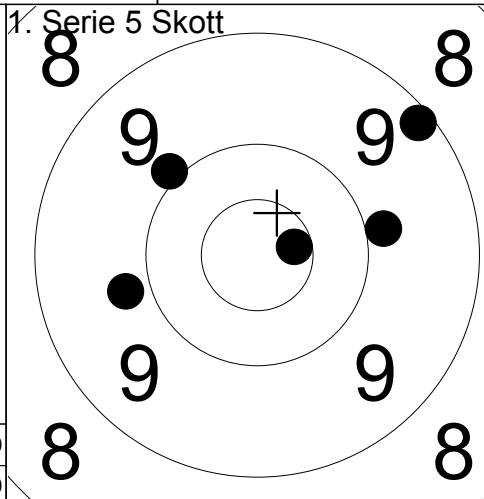

- 1: 9.2 ↗
- 2: 9.9 →
- 3: 9.9 ↗
- 4: *10.6 →
- 5: 9.8 ←

Serie	46.0
Total	46.0

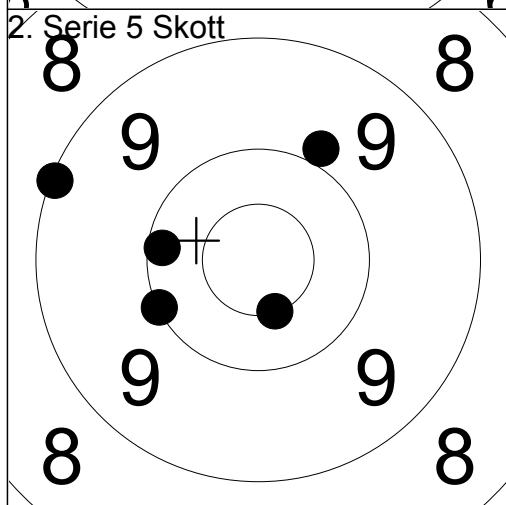

- 1: 9.9 ↗
- 2: 9.1 ↖
- 3: *10.5 ↓
- 4: 10.1 ←
- 5: 10.0 ↖

Serie	48.0
Total	94.0

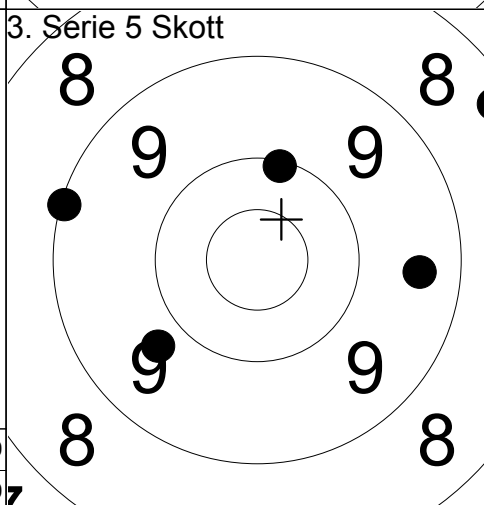

- 1: 9.1 ↖
- 2: 9.4 →
- 3: 8.3 ↗
- 4: 10.1 ↑
- 5: 9.7 ↖

Serie	45.0
Total	139.0

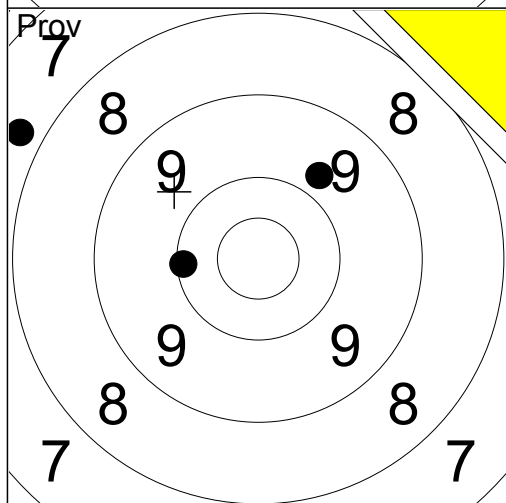

- 1: 10.1 ←
- 2: 7.7 ↖
- 3: 9.8 ↗

Serie	26.0
Total	139.0

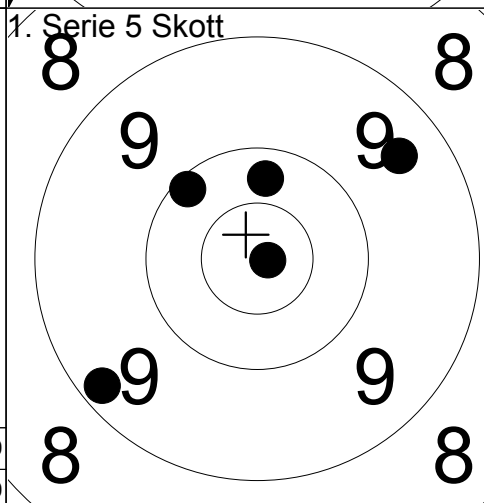

- 1: 9.2 ↖
- 2: 10.3 ↑
- 3: 9.4 ↗
- 4: 10.1 ↖
- 5: *10.9 →

Serie	48.0
Total	187.0

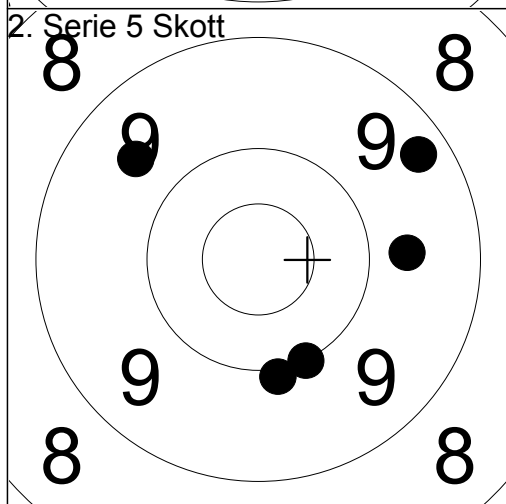

- 1: 9.6 ↗
- 2: 10.0 ↓
- 3: 10.0 ↓
- 4: 9.7 →
- 5: 9.3 ↗

Serie	47.0
Total	234.0

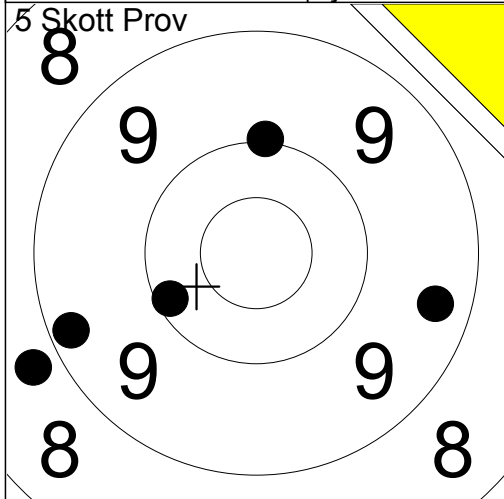

1:	10.1	↙
2:	8.8	↙
3:	9.2	↙
4:	10.0	↑
5:	9.4	→
Serie		46.0
Total		0.0

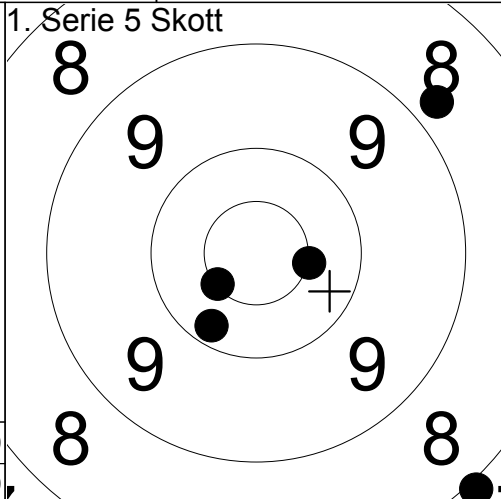

1:	8.8	↗
2:	*10.5	↙
3:	*10.5	→
4:	8.0	↘
5:	10.2	↘
Serie		46.0
Total		46.0

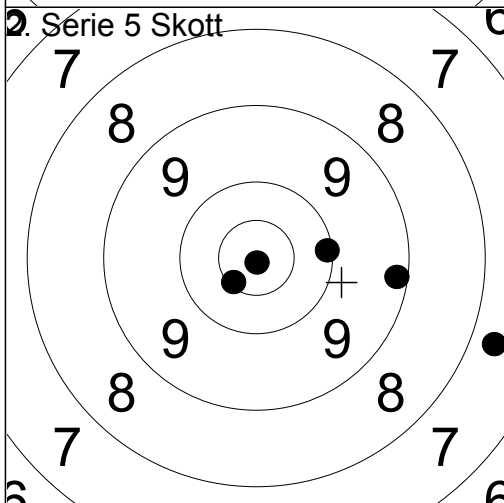

1:	7.7	→
2:	10.1	→
3:	9.2	→
4:	*10.5	↙
5:	*10.9	↓
Serie		46.0
Total		92.0

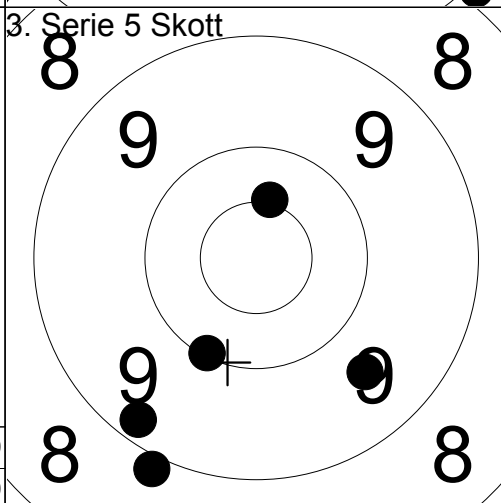

1:	10.1	↘
2:	9.6	↘
3:	9.2	↙
4:	8.9	↙
5:	*10.5	↑
Serie		46.0
Total		138.0

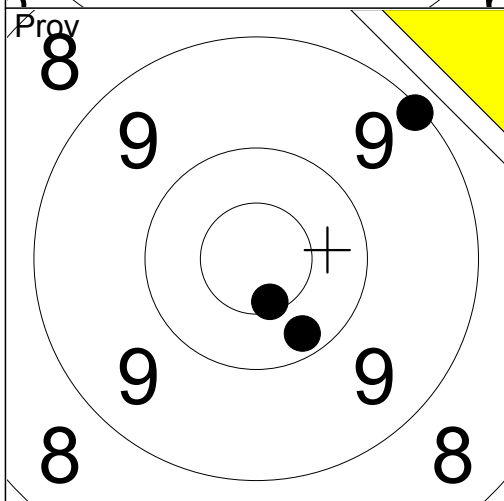

1:	9.1	↗
2:	*10.6	↘
3:	10.2	↘
Serie		29.0
Total		138.0

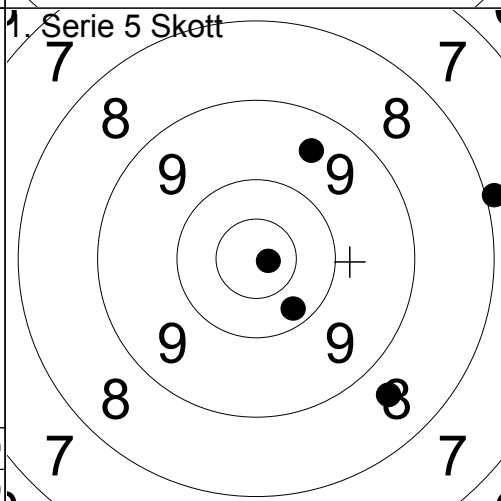

1:	7.9	→
2:	10.2	↘
3:	9.5	↑
4:	*10.8	→
5:	8.6	↘
Serie		44.0
Total		182.0

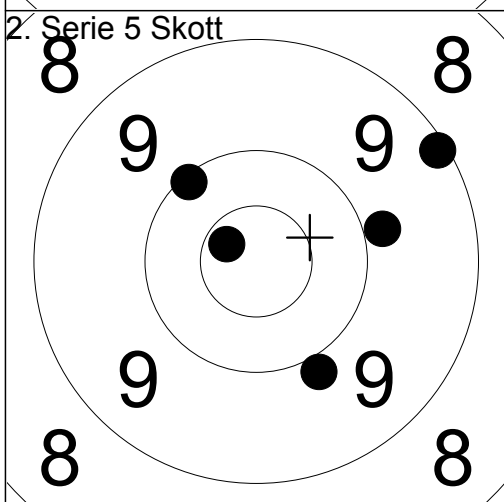

1:	*10.7	↗
2:	9.1	↗
3:	9.9	→
4:	10.1	↗
5:	9.9	↘
Serie		47.0
Total		229.0