

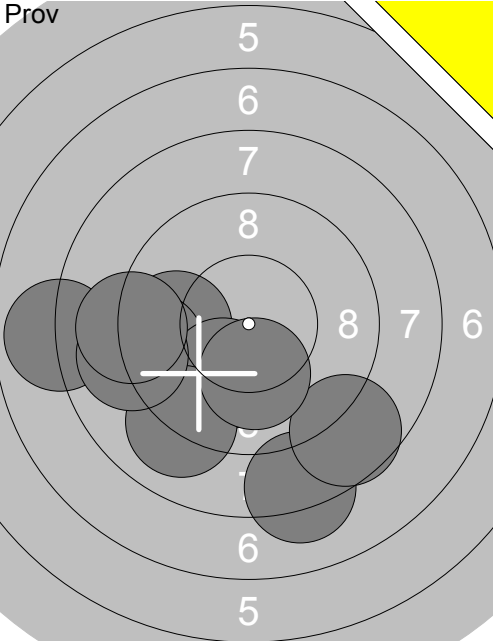



Skjutlag	Tavla	Karin Johansson	
1	1	Vindeln	Vännäs
28.01.2017	Förbundsmästerskap 2017	Ramselefors SKF	
Prov		1: 9.8 ← 2: 7.9 ← 3: 8.2 ↓ 4: 9.3 ← 5: 10.1 ↓ 6: 9.0 ↓ 7: 8.6 ↓ 8: 9.0 ← 9: 10.1 ↓ 10: 9.1 ← Serie 88.0 Total 0.0	Prov  11: 10.3x↓ 12: 9.2 ↓ 13: 10.4x← Serie 29.0 Total 0.0
40 Skott		1: 9.9 ↓ 2: 10.0← 3: 9.2 ← 4: 9.0 ← 5: 8.7 ← 6: 10.0← 7: 9.2 ↓ 8: 8.0 ← 9: 9.5 → 10: 8.5 ↓ Serie 89.0 Total 89.0	40 Skott  11: 10.3x↑ 12: 9.4 ↗ 13: 9.2 → 14: 9.8 ↖ 15: 10.4x→ 16: 9.4 ↗ 17: 10.3x→ 18: 9.7 ← 19: 9.4 → 20: 10.6x↖ Serie 94.0 Total 183.0
40 Skott		21: 10.4x↖ 22: 7.6 ← 23: 10.4x↖ 24: 9.3 ← 25: 10.0← 26: 9.6 → 27: 9.0 ← 28: 10.5x↓ 29: 10.1 ↓ 30: 8.0 ← Serie 92.0 Total 275.0	40 Skott  31: 9.0 ← 32: 6.0 ← 33: 9.6 ↖ 34: 9.8 ← 35: 9.5 → 36: 9.5 → 37: 10.4x→ 38: 8.0 → 39: 10.0 ↓ 40: 10.1 → Serie 89.0 Total 364.0

Skjuttag	Tavla	Carl Bergling	
1	2	Umeå	Jun Vb
28.01.2017	Förbundsmästerskap 2017	Ramselefors SKF	
Prov 	1: 10.3x ↘ 2: 9.5 ↙ 3: 9.8 ↖ 4: 9.8 ↗ 5: 9.7 ↑ 6: 9.5 → 7: 10.1 ↓ 8: 10.4x ↘ Serie 75.0 Total 0.0	40 Skott 	1: 10.5x ↘ 2: 9.4 → 3: 10.1 → 4: 9.7 ↑ 5: 9.1 ↓ 6: 10.8x ↑ 7: 9.8 ↙ 8: 9.6 ↗ 9: 9.4 ↓ 10: 8.6 → Serie 92.0 Total 92.0
40 Skott 	11: 9.5 ↘ 12: 9.6 ↑ 13: 9.8 → 14: 10.1 ↘ 15: 10.4x ↑ 16: 10.6x ← 17: 10.0 ↓ 18: 9.1 ↘ 19: 8.7 ↖ 20: 10.2x ↗ Serie 94.0 Total 186.0	40 Skott 	21: 10.6x ↗ 22: 9.5 ← 23: 9.2 ↘ 24: 9.4 ← 25: 10.1 ↓ 26: 10.3x ↘ 27: 10.1 ↗ 28: 9.5 → 29: 10.1 ↓ 30: 10.6x ↗ Serie 96.0 Total 282.0
40 Skott 	31: 9.7 ↗ 32: 9.4 ↙ 33: 9.8 ← 34: 9.8 ↘ 35: 9.8 ↖ 36: 10.1 ↖ 37: 9.2 ↗ 38: 9.9 → 39: 10.5x ↑ 40: 9.2 ↓ Serie 92.0 Total 374.0		

Skjutlag	Tavla	Emma Eriksson	
1	3		
Vindeln	Ramselefors	Jun	Vb
28.01.2017	Förbundsmästerskap 2017	Ramselefors SKF	
	1: 9.0 ↘ 2: 8.8 ↓ 3: 8.6 ↓ 4: 10.1 ↙ 5: 7.4 → 6: 9.5 →		1: 9.0 ↘ 2: 10.5x↘ 3: 10.6x→ 4: 8.3 ↘ 5: 8.7 → 6: 8.4 → 7: 8.4 ↓ 8: 7.9 → 9: 9.7 ↓ 10: 8.6 ←
	Serie 51.0 Total 0.0		Serie 85.0 Total 85.0
	11: 9.7 ← 12: 9.9 → 13: 9.0 ↘ 14: 8.9 ↘ 15: 9.4 ← 16: 10.3x↘ 17: 10.0 ↓ 18: 10.2x↘ 19: 10.1 ← 20: 10.4x↘		21: 8.7 ← 22: 7.8 ← 23: 9.6 ↓ 24: 9.8 ↓ 25: 9.8 ← 26: 10.0 ↙ 27: 9.3 ↗ 28: 9.9 ← 29: 10.0 ↘ 30: 8.3 →
	Serie 94.0 Total 179.0		Serie 88.0 Total 267.0
	31: 9.2 ← 32: 10.7x↘ 33: 10.4x→ 34: 10.1 → 35: 10.1 → 36: 9.6 ← 37: 8.1 ← 38: 10.3x↘ 39: 9.7 ← 40: 8.6 ↖		
	Serie 93.0 Total 360.0		

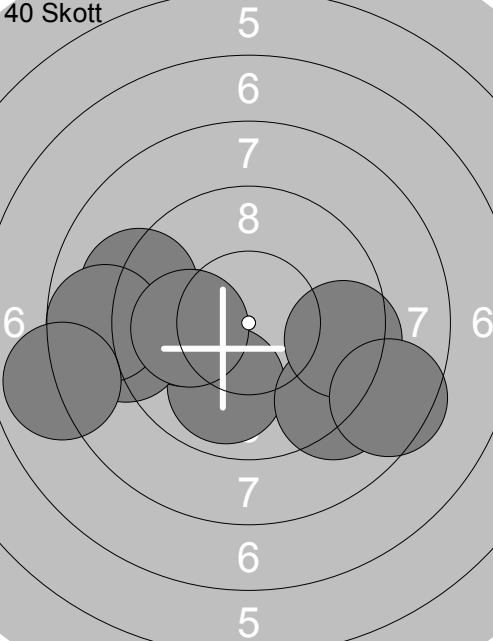
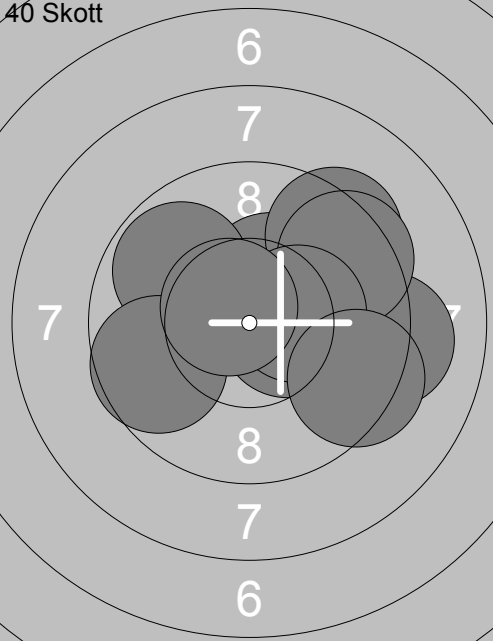
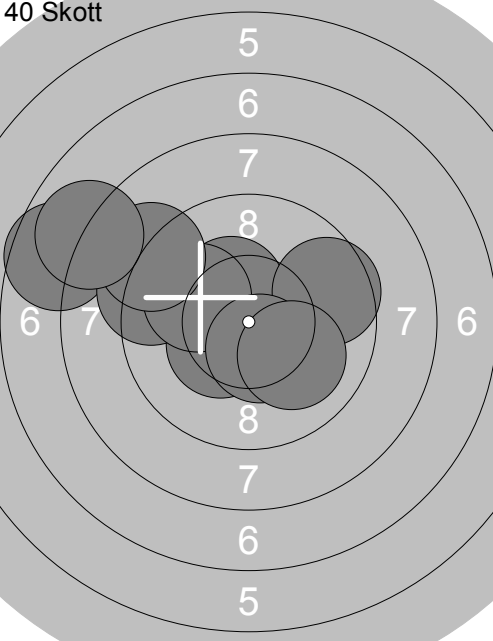
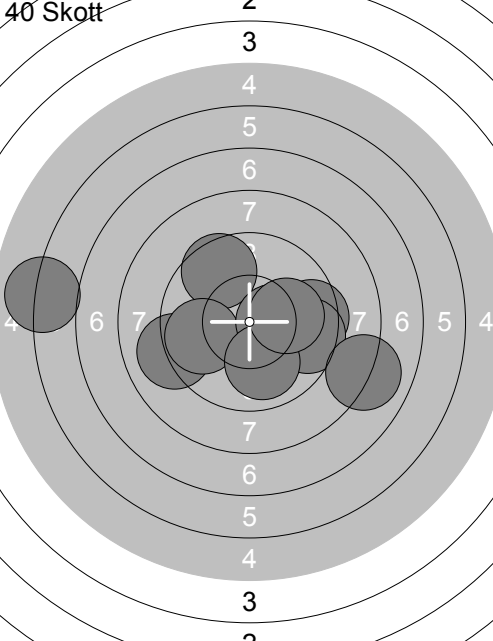
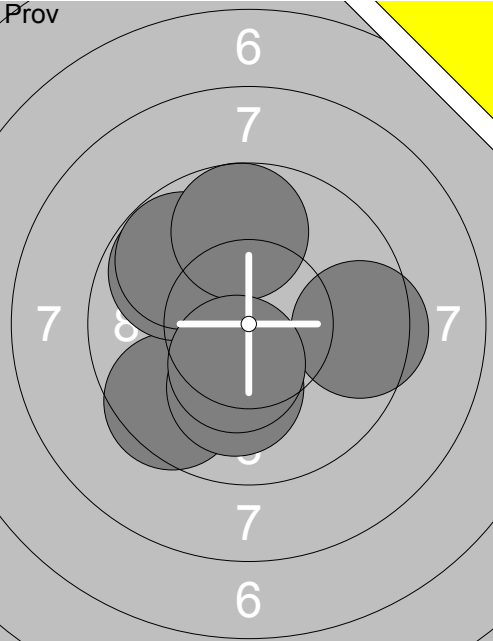
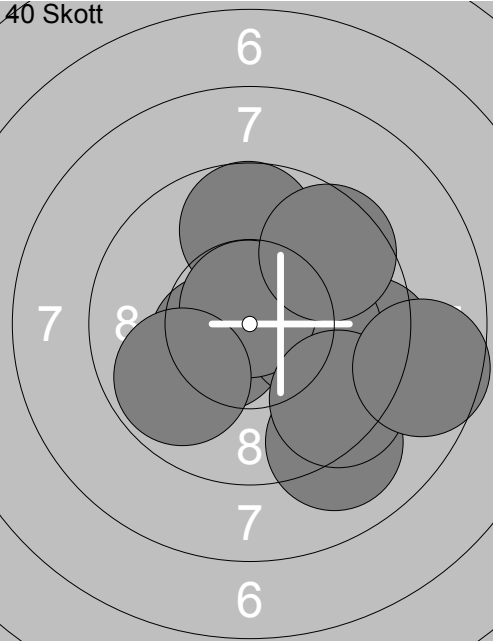
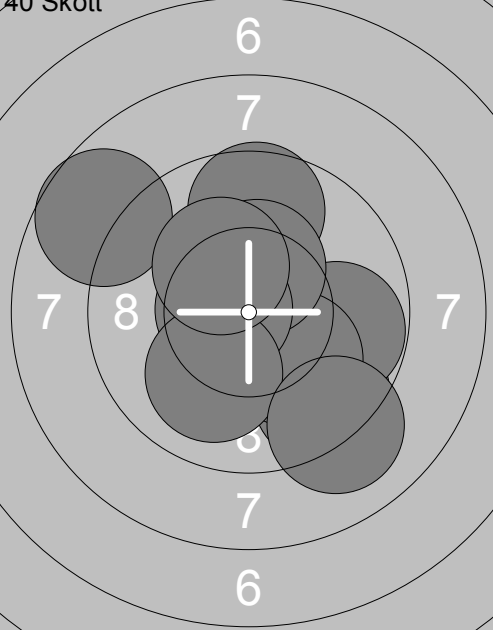
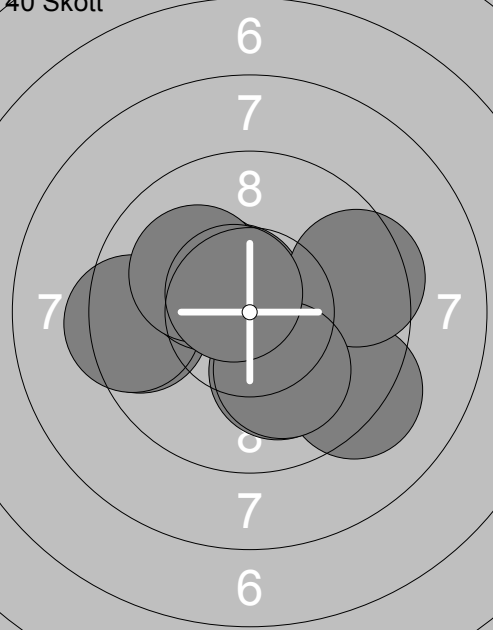
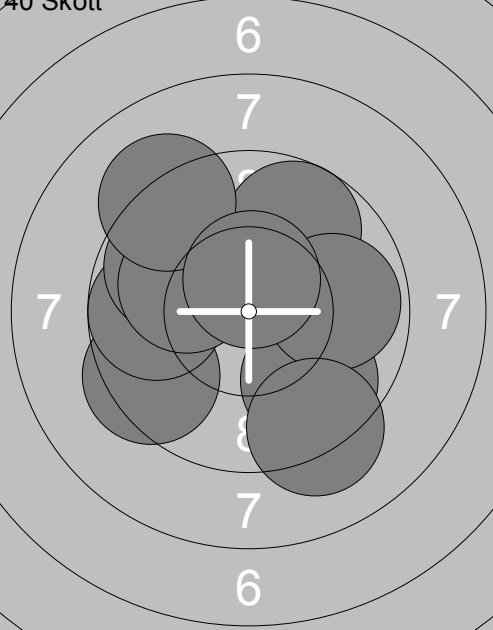
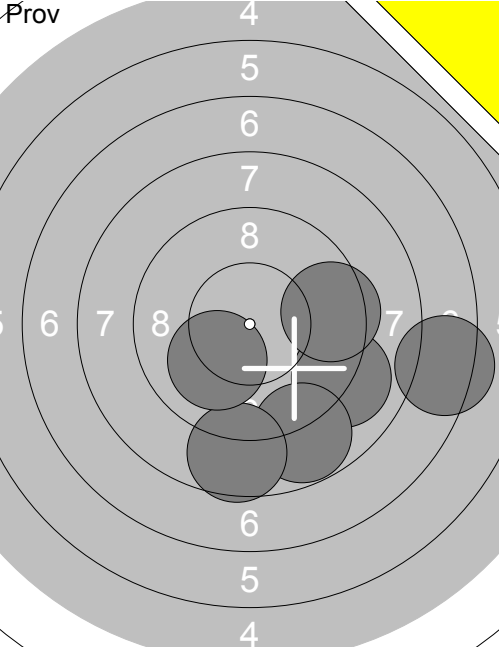
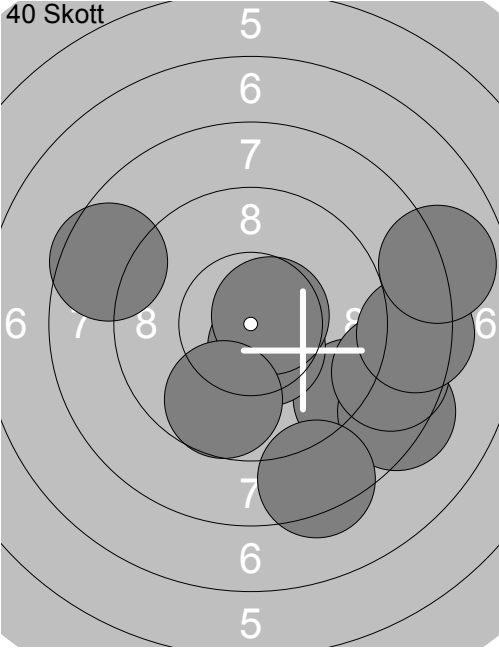
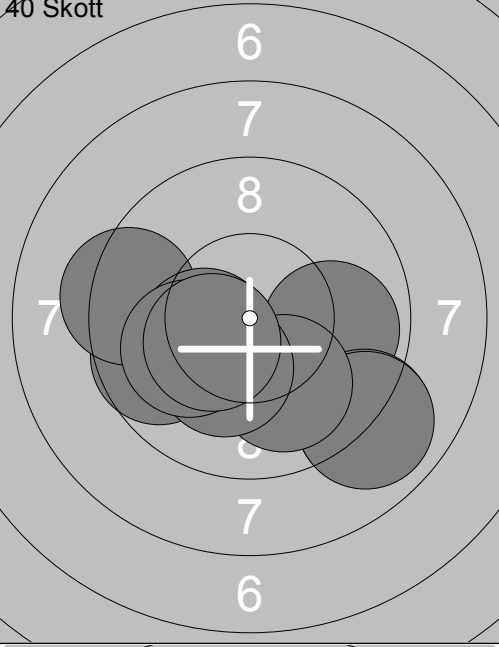
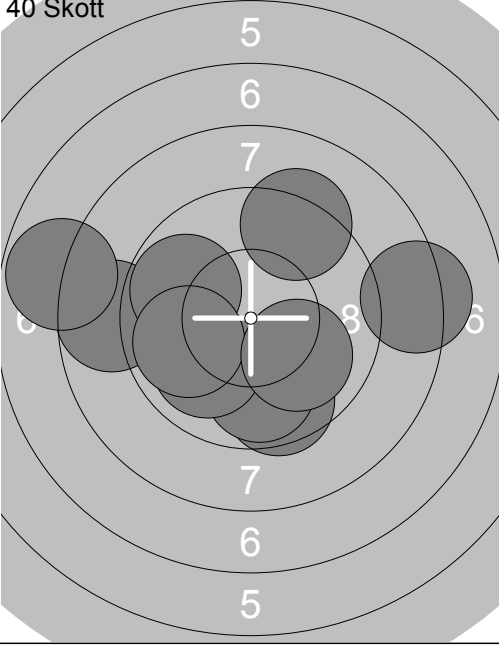
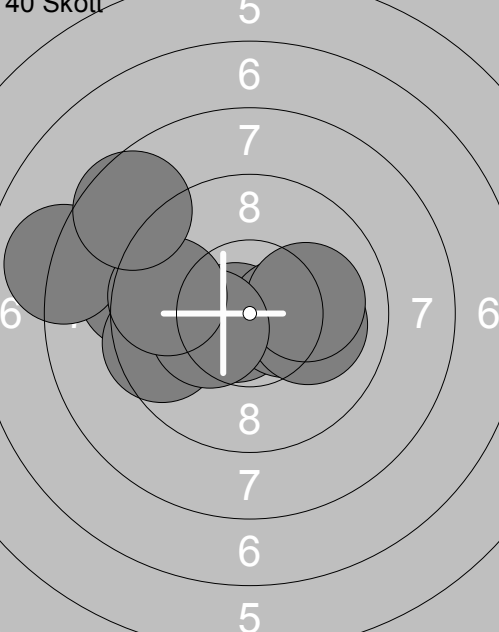
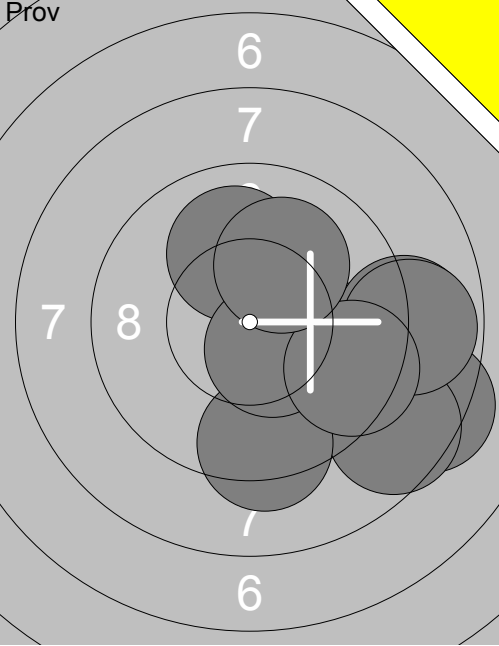
Skjuttag	Tavla	Nicolle Nygren																					
1	5	Vindeln	Umeå	Jun	Vb																		
28.01.2017		Förbundsmästerskap 2017		Ramselefors SKF																			
Pröv		1: 8.4 ↘	2: 9.4 →	3: 8.6 ↘	4: 8.9 →	5: 9.3 ↓	6: 10.0 ↑	7: 8.8 →	8: 10.5x↘	9: 9.5 →	10: 10.1 ↗	Pröv		11: 10.8x↗	12: 10.0 ↘								
		Serie	89.0	Serie	20.0	Total	0.0	Total	0.0														
40 Skott		1: 10.3x↘	2: 10.3x→	3: 10.4x↓	4: 9.7 ↘	5: 10.2x↘	6: 9.3 ↘	7: 9.7 →	8: 9.7 →	9: 9.9 ↘	10: 9.4 ↑	40 Skott		11: 10.4x↗	12: 10.0 ↗	13: 9.3 ↘	14: 9.6 ↑	15: 9.8 ↗	16: 10.2x→	17: 10.8x↑	18: 10.2x↘	19: 10.1 ↘	20: 10.0 →
		Serie	94.0	Serie	97.0	Total	94.0	Total	191.0														
40 Skott		21: 10.8x↘	22: 10.1 ↙	23: 10.5x↗	24: 10.2x↘	25: 10.4x↗	26: 9.4 ↗	27: 9.4 ↙	28: 10.5x↘	29: 9.7 ↘	30: 10.1 ↑	40 Skott		31: 9.1 ↘	32: 9.8 ↗	33: 9.5 ↗	34: 8.2 ↘	35: 9.9 ↓	36: 10.9x↓	37: 8.9 ↓	38: 10.5x↘	39: 10.2x→	40: 9.0 ↓
		Serie	97.0	Serie	91.0	Total	288.0	Total	379.0														

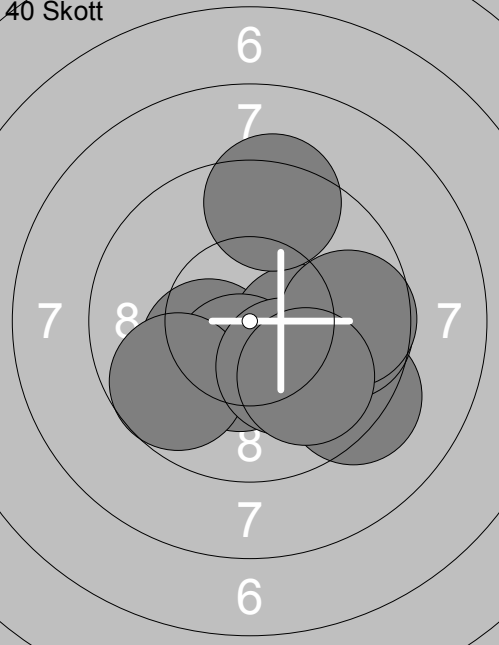
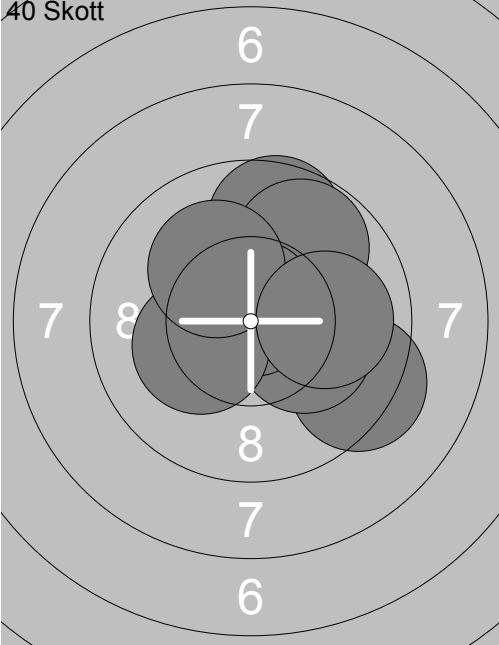
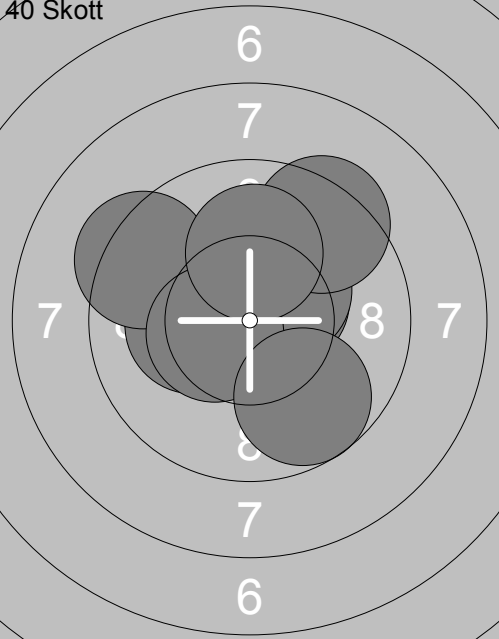
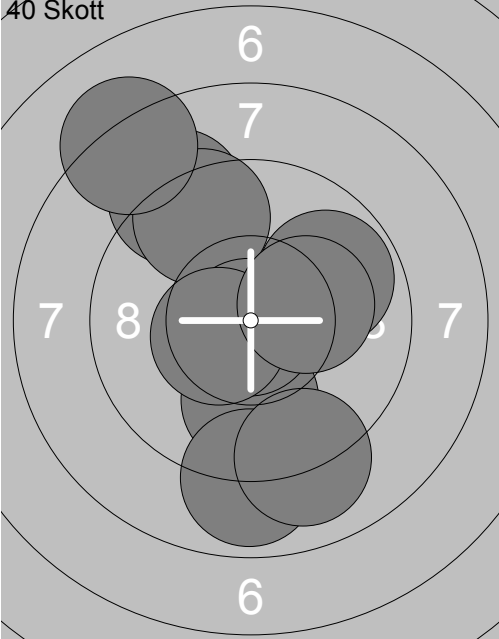
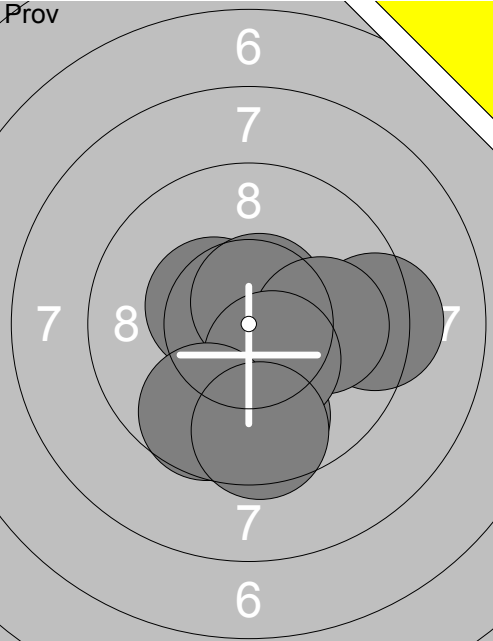
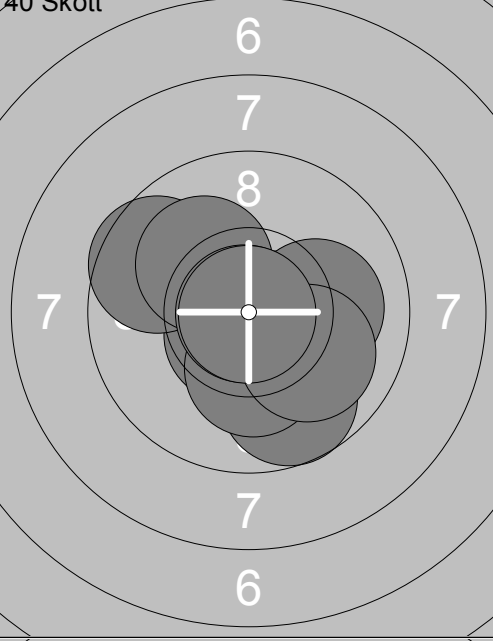
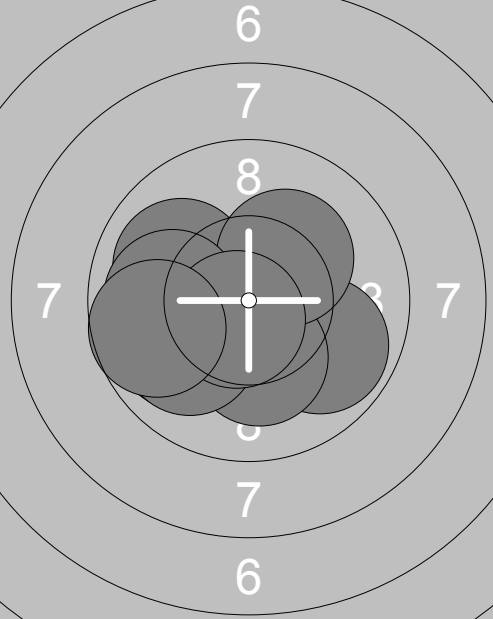
Skjuttag	Tavla	Maria Hägglund	
1	6		
Vindeln	Ramselefors	Sen	Vb
28.01.2017	Förbundsmästerskap 2017	Ramselefors SKF	
Prov		1: 10.1 ↓ 2: 9.7 ↓ 3: 10.8x ↗ 4: 9.3 → 5: 10.4x ↘ 6: 10.6x ↗ 7: 10.0 → 8: 10.4x ↘ 9: 9.7 ↓ 10: 9.6 ↓	11: 10.2x → 12: 10.7x ↓ 13: 9.5 ↓ 14: 10.3x ↗ 15: 10.6x ↘ 16: 10.8x ↘
		Serie 96.0	Serie 59.0
		Total 0.0	Total 0.0
40 Skott		1: 10.6x ↘ 2: 9.6 ↖ 3: 10.1 ↖ 4: 9.7 ↓ 5: 10.6x → 6: 10.2x ↓ 7: 10.1 → 8: 10.0 ↘ 9: 10.9x ↖ 10: 10.9x ↘	11: 10.8x ↘ 12: 10.5x ↘ 13: 10.9x ↘ 14: 10.1 ↖ 15: 10.4x ↓ 16: 10.5x ↓ 17: 10.1 ↓ 18: 10.2x ↘ 19: 10.5x ↓ 20: 10.6x ↘
		Serie 98.0	Serie 100.0
		Total 98.0	Total 198.0
40 Skott		21: 9.9 ↘ 22: 10.7x ↗ 23: 10.2x ↓ 24: 9.9 ↖ 25: 10.0 ↖ 26: 10.2x ↗ 27: 10.0 ↖ 28: 9.9 ← 29: 10.7x ↘ 30: 9.7 ←	31: 10.6x ↘ 32: 9.6 ↖ 33: 9.9 ↗ 34: 10.6x ↖ 35: 10.4x ↘ 36: 9.9 ← 37: 10.2x ↖ 38: 10.0 ↖ 39: 9.8 ↘ 40: 9.8 ↖
		Serie 96.0	Serie 95.0
		Total 294.0	Total 389.0

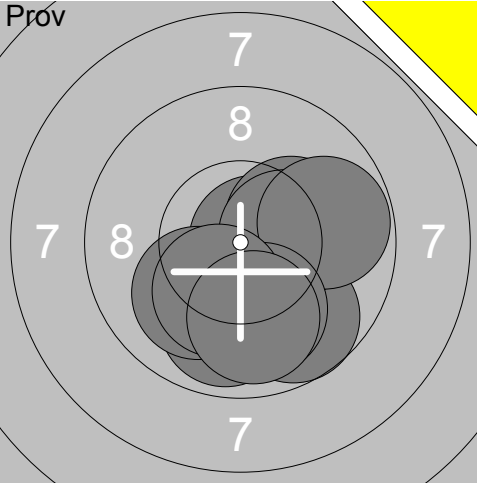
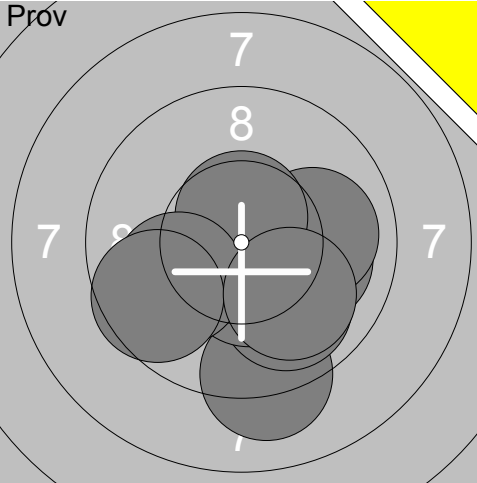
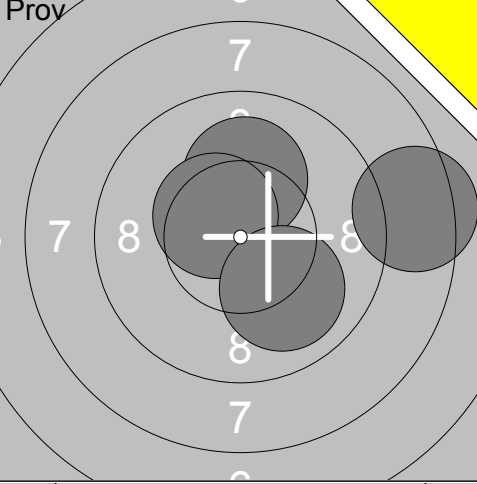
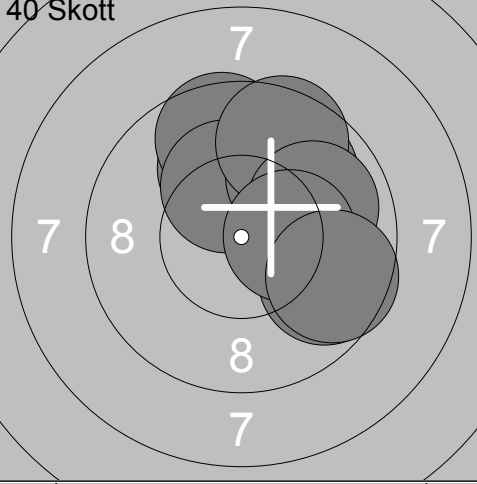
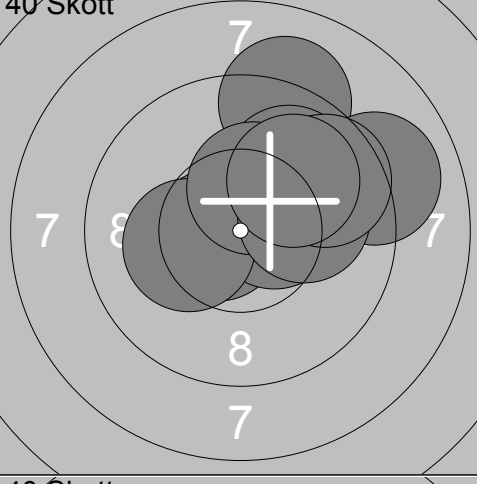
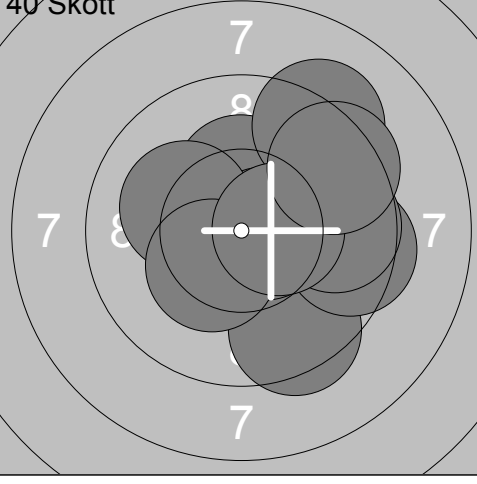
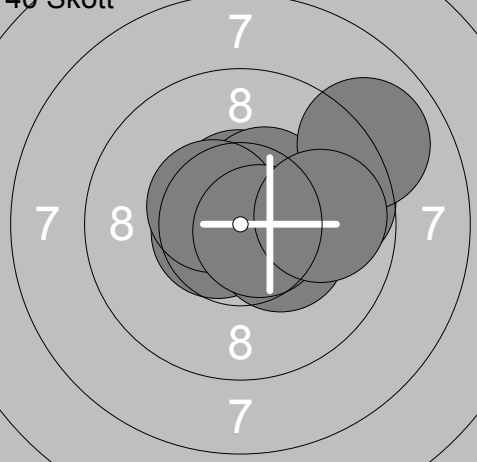
Skjutlag	Tavla	Elliot Nilsson	
1	11		
Vindeln	Drängsmark	9	Vb
28.01.2017	Förbundsmästerskap 2017	Ramselefors SKF	
Pröv 	1: 9.7 ↘ 2: 10.7x → 3: 10.2x → 4: 10.3x → 5: 9.8 → 6: 9.9 ↓ 7: 10.0 ↓ 8: 10.1 ↙ 9: 10.2x ↓ 10: 9.9 ↓ Serie 96.0 Total 0.0	Pröv 	11: 10.3x → 12: 9.1 ↓ 13: 10.0 → 14: 10.0 → 15: 9.9 ↓ 16: 10.4x ↓ 17: 10.6x ↑ 18: 10.0 ↙ 19: 9.6 ↙ 20: 10.0 ↘ Serie 97.0 Total 0.0
Pröv 	21: 10.1 ↑ 22: 8.4 → 23: 10.5x ↖ 24: 10.0 ↓ Serie 38.0 Total 0.0	40 Skott 	1: 10.0 ↑ 2: 9.7 → 3: 9.6 ↑ 4: 10.2x ↑ 5: 10.2x ↑ 6: 9.9 ↗ 7: 9.6 ↑ 8: 9.9 → 9: 10.3x → 10: 9.6 → Serie 94.0 Total 94.0
40 Skott 	11: 9.1 ↑ 12: 10.6x ← 13: 9.9 ↗ 14: 10.5x → 15: 9.0 → 16: 10.2x ← 17: 10.4x ↑ 18: 10.1 → 19: 9.6 ↗ 20: 10.0 ↗ Serie 96.0 Total 190.0	40 Skott 	21: 10.3x ↑ 22: 9.4 ↓ 23: 9.2 ↗ 24: 9.5 → 25: 9.7 → 26: 10.6x → 27: 10.1 ↖ 28: 10.3x ↙ 29: 10.4x → 30: 9.5 ↗ Serie 95.0 Total 285.0
40 Skott 	31: 10.6x ← 32: 9.7 → 33: 10.6x → 34: 10.6x ↑ 35: 10.4x ↗ 36: 10.3x ↘ 37: 9.0 ↗ 38: 10.5x ↖ 39: 10.7x → 40: 9.9 → Serie 97.0 Total 382.0		

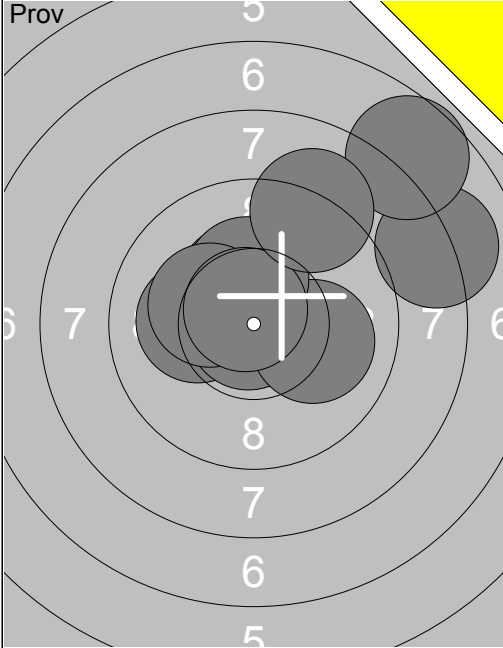
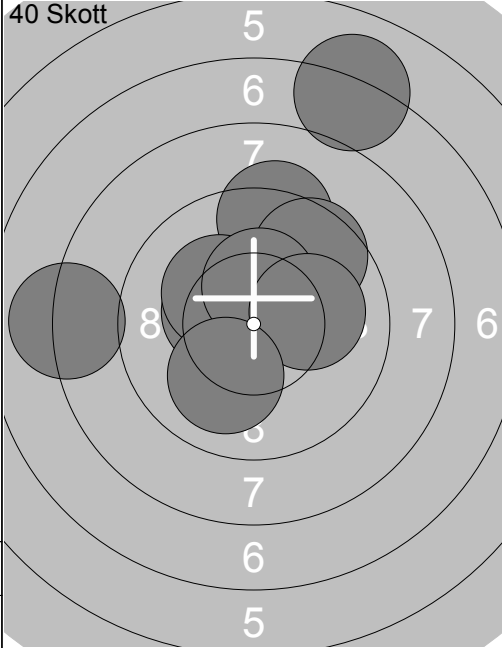
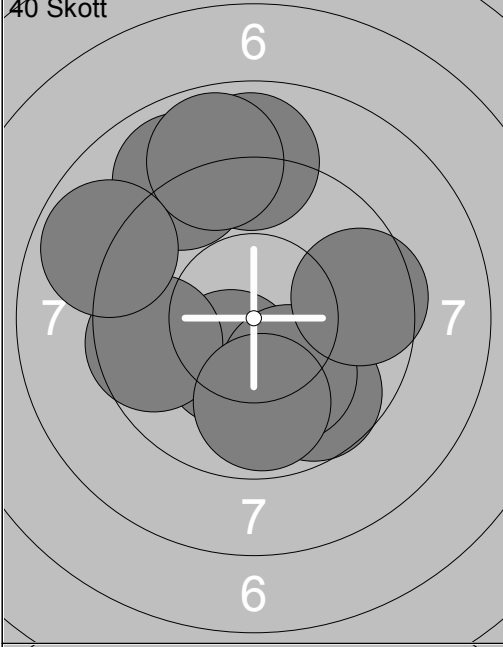
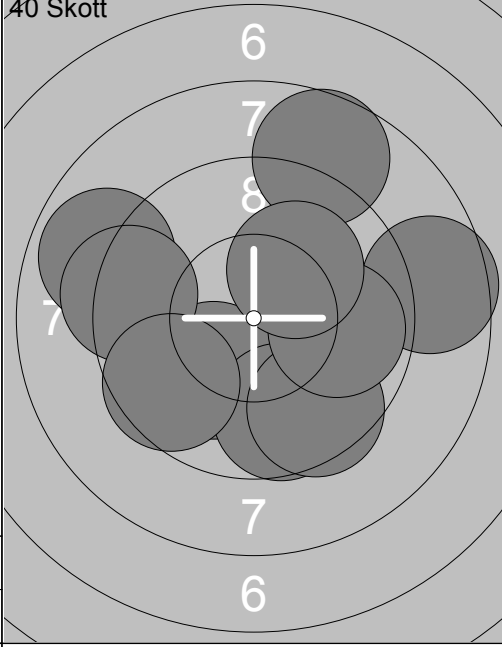
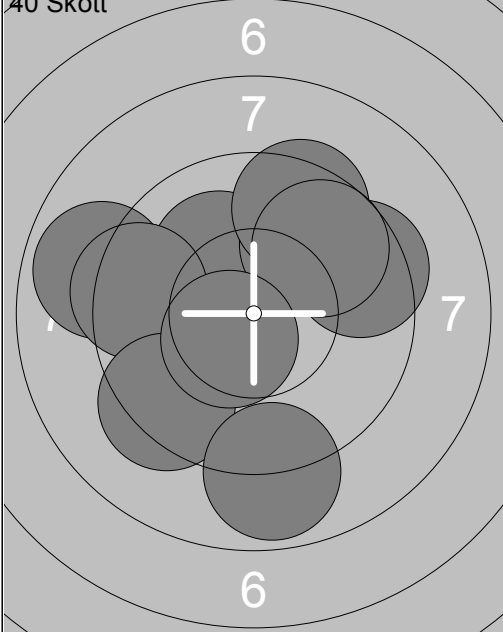
Skjutlag	Tavla	Adam Tiburzi		
1	12	Drängsmark	9	Vb
28.01.2017	Förbundsmästerskap 2017	Ramselefors SKF		
Prov		1: 8.1 → 2: 7.7 ↗ 3: 10.1 ← 4: 10.4x ↗ 5: 10.9x ↘ 6: 10.1 → 7: 10.3x ↗ 8: 10.3x ↘ 9: 10.7x ↘ 10: 9.1 ↗	40 Skott	 1: 10.2x ↗ 2: 10.4x ↘ 3: 9.3 ↗ 4: 8.1 ← 5: 7.1 ↗ 6: 9.6 ↗ 7: 10.2x ↘ 8: 10.4x ↗ 9: 10.1 → 10: 10.0 ↘
		Serie 94.0		Serie 93.0
		Total 0.0		Total 93.0
40 Skott		11: 10.4x ↘ 12: 9.7 ↘ 13: 8.9 ↗ 14: 10.1 ↘ 15: 9.5 → 16: 9.6 ← 17: 8.9 ↗ 18: 9.8 ↘ 19: 8.8 ↗ 20: 8.9 ←	40 Skott	 21: 10.1 ↘ 22: 8.9 ← 23: 9.7 ↘ 24: 8.7 ↗ 25: 9.5 ↘ 26: 9.3 ← 27: 8.6 → 28: 9.8 → 29: 9.6 ↘ 30: 10.1 ↗
		Serie 88.0		Serie 89.0
		Total 181.0		Total 270.0
40 Skott		31: 8.9 ← 32: 10.1 ↗ 33: 9.4 ← 34: 9.4 → 35: 9.8 ↗ 36: 9.4 ↗ 37: 9.7 ↗ 38: 9.3 ↘ 39: 8.9 ↘ 40: 10.5x ↘		
		Serie 90.0		
		Total 360.0		

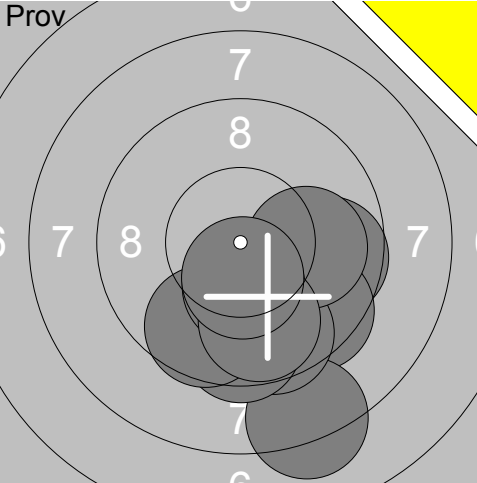
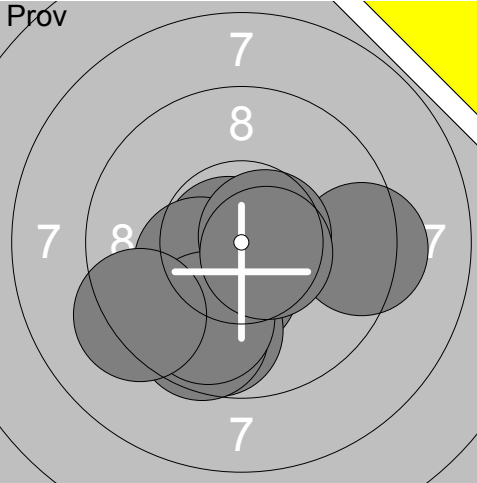
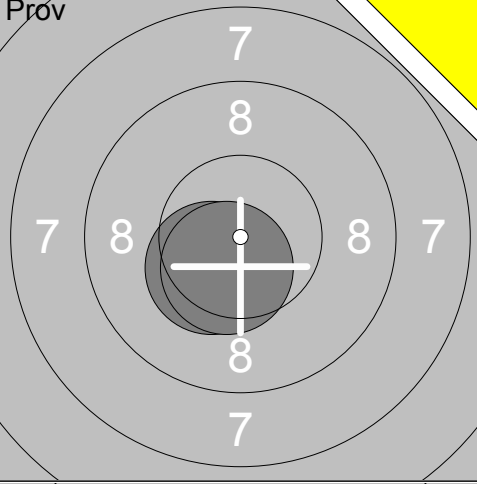
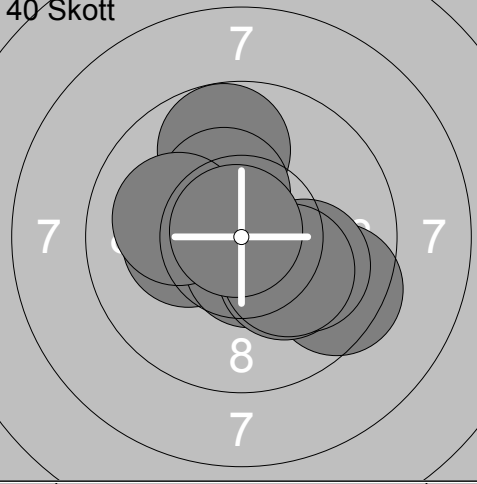
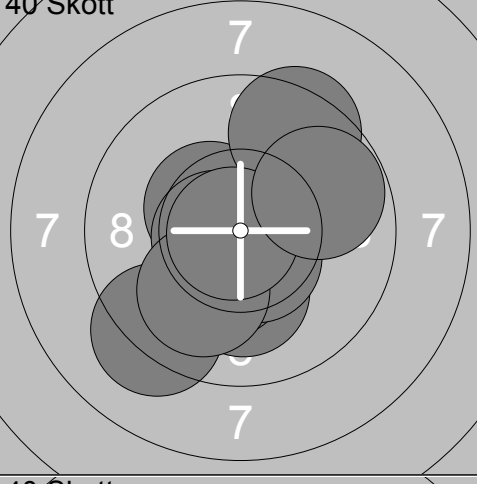
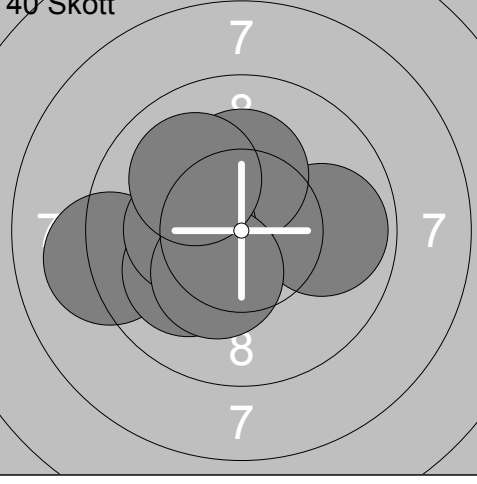
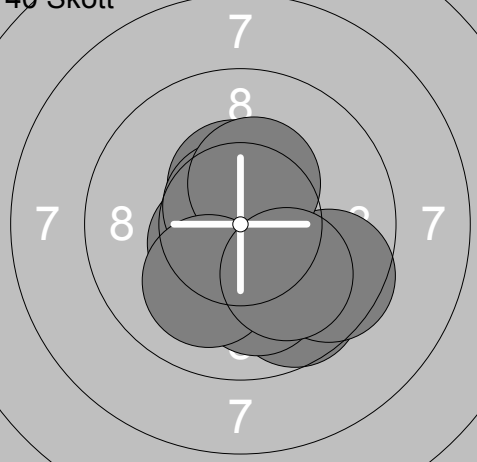
Skjutlag 1	Tavla 13	Jonathan Ebbhagen			
Vindeln	Ramselefors	7	Vb		
28.01.2017	Förbundsmästerskap 2017	Ramselefors SKF			
Prov		1: 9.7 → 2: 9.5 ↘ 3: 8.2 ↘ 4: 9.5 ↘ 5: 10.0 → 6: 9.5 ↘ 7: 9.6 ↘ 8: 10.3x ↘ 9: 9.8 ↘ 10: 10.4x ↘	Prov		11: 10.4x ↓ 12: 9.7 ↓ 13: 9.3 → 14: 10.8x ← 15: 10.3x ← 16: 9.6 ↓ 17: 9.8 ↓ 18: 10.6x → 19: 10.6x → 20: 9.3 ↙
	Serie 92.0		Serie 95.0		
	Total 0.0		Total 0.0		
Prov		21: 10.4x ↙ 22: 10.5x ↙	40 Skott		1: 9.7 ↑ 2: 10.2x ← 3: 10.6x ↓ 4: 9.5 ↘ 5: 10.2x ↘ 6: 10.0 → 7: 10.3x ↗ 8: 10.2x ↘ 9: 10.1 ← 10: 10.8x ↗
	Serie 20.0		Serie 98.0		
	Total 0.0		Total 98.0		
40 Skott		11: 10.4x ↗ 12: 9.2 ↘ 13: 10.1 ↓ 14: 10.4x ↘ 15: 9.4 ↗ 16: 10.6x ← 17: 10.5x ↘ 18: 10.0 ↘ 19: 10.8x ← 20: 9.8 →	40 Skott		21: 10.2x ↑ 22: 10.8x ↗ 23: 10.6x ← 24: 9.1 ← 25: 10.1 ↘ 26: 9.9 → 27: 10.2x ↑ 28: 10.2x ← 29: 10.3x ↘ 30: 10.0 ↗
	Serie 97.0		Serie 98.0		
	Total 195.0		Total 293.0		
40 Skott		31: 9.7 ↘ 32: 10.4x ↗ 33: 10.8x ↘ 34: 9.6 ↘ 35: 10.5x ← 36: 10.0 ↘ 37: 10.7x ↗ 38: 10.4x ↗ 39: 10.1 ↘ 40: 10.0 ↘			
	Serie 98.0				
	Total 391.0				

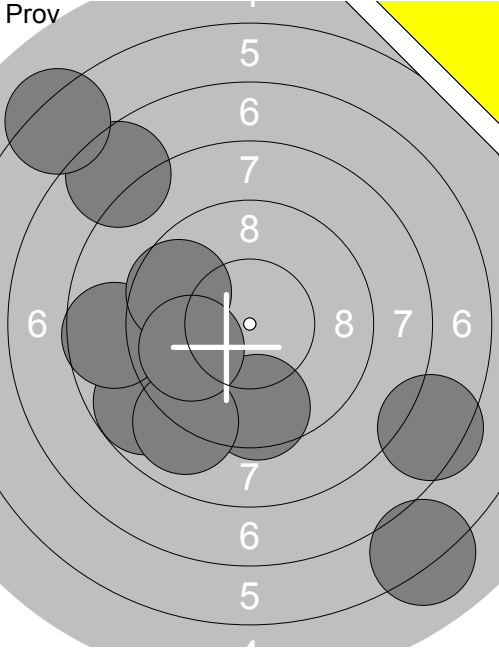
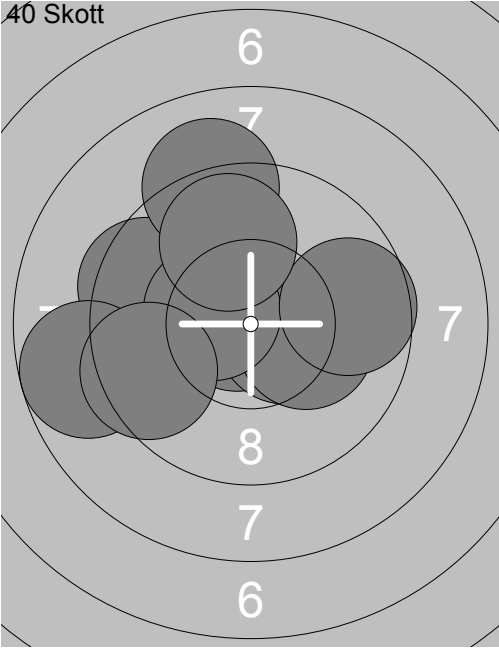
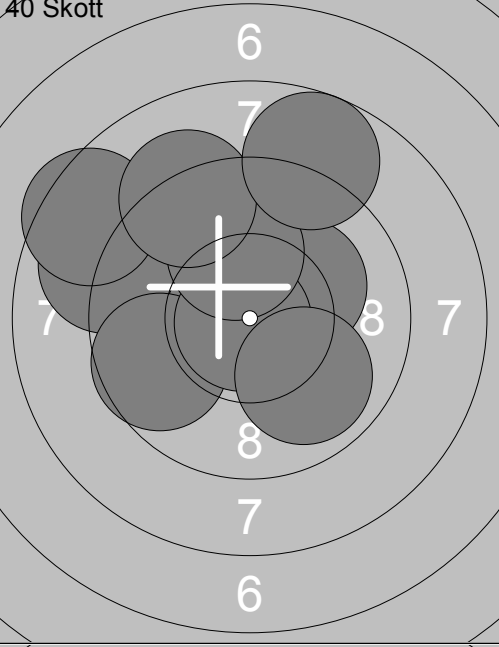
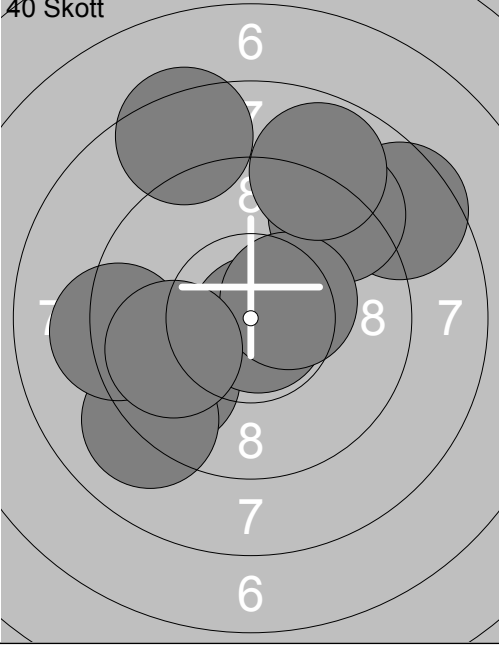
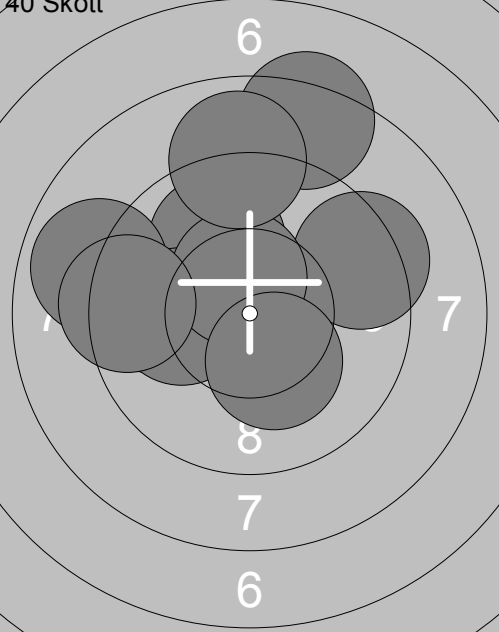
Skjutlag	Tavla	Ylva Lundstedt		
1	14	Ramselefors	7	Vb
28.01.2017	Föbunds mästerskap 2017	Ramselefors SKF		
	1: 7.4 ↘		1: 10.8 ✕	
	2: 8.8 ↙		2: 9.5 ↙	
	3: 8.6 ←		3: 9.1 ↑	
	4: 9.5 ↓		4: 8.7 ←	
	5: 9.0 ↙		5: 10.5 ✕	
	6: 6.1 ↙		6: 10.2 ✕	
	7: 7.6 ↗		7: 10.4 ✕	
	8: 9.6 ←		8: 9.5 ←	
	9: 6.2 ↗		9: 9.7 →	
	10: 9.9 ←		10: 9.8 ↑	
	Serie 78.0		Serie 93.0	
	Total 0.0		Total 93.0	
	11: 9.5 ↙		21: 8.6 ↗	
	12: 9.0 ←		22: 9.6 ↙	
	13: 8.5 ↙		23: 10.8 ✕	
	14: 9.6 ←		24: 9.1 ↙	
	15: 10.2 ✕		25: 9.2 ←	
	16: 10.8 ✕		26: 9.2 ↗	
	17: 10.1 ↑		27: 8.4 ↑	
	18: 9.2 ↗		28: 10.4 ✕	
	19: 9.9 ↘		29: 9.9 ←	
	20: 8.7 ↗		30: 8.8 ↗	
	Serie 91.0		Serie 89.0	
	Total 184.0		Total 273.0	
	31: 9.7 ←			
	32: 8.3 ↑			
	33: 9.9 ↗			
	34: 8.9 ←			
	35: 9.3 ↗			
	36: 10.1 ←			
	37: 10.5 ✕			
	38: 8.9 ↑			
	39: 9.3 ←			
	40: 10.3 ✕			
	Serie 90.0			
	Total 363.0			

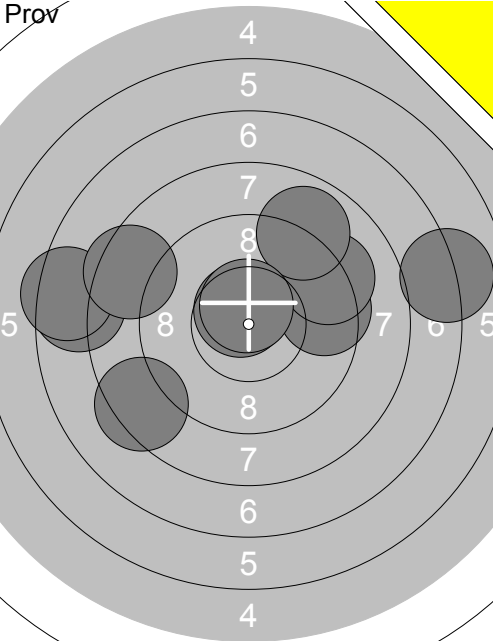
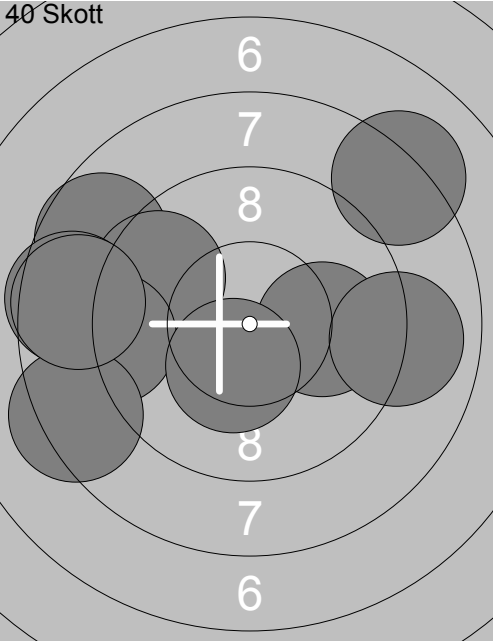
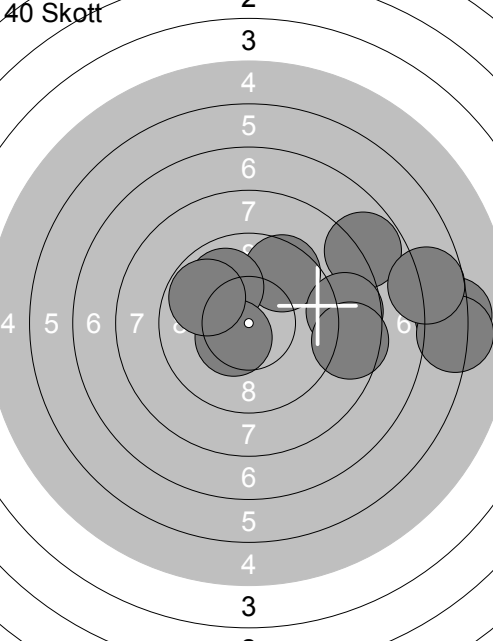
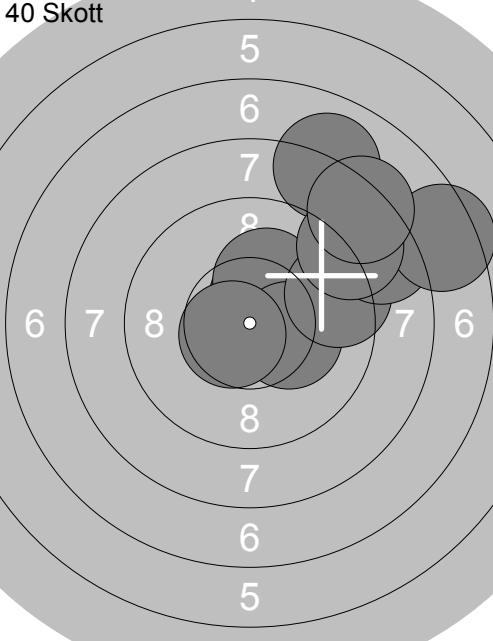
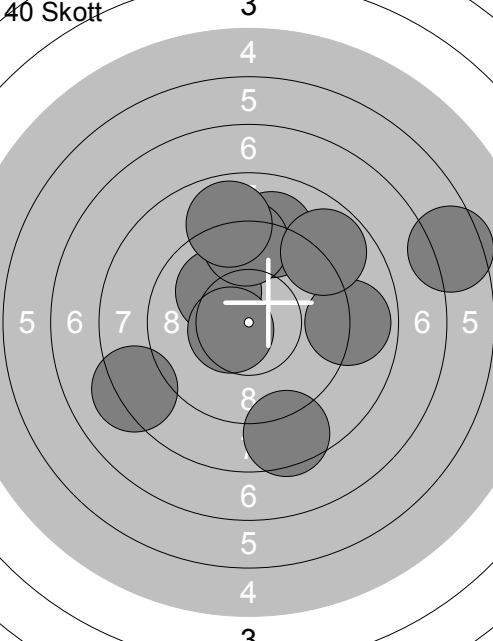
Skjutlag 1	Tavla 15	Alex Sandström		
Vindeln	Ramselefors	9	Vb	
28.01.2017	Förbundsmästerskap 2017	Ramselefors SKF		
Prov		1: 7.7 ← 2: 9.5 → 3: 9.2 ↗ 4: 7.0 → 5: 8.4 ↙ 6: 7.4 ← 7: 8.9 ↗ 8: 8.5 ← 9: 10.6x ↘ 10: 10.6x ↗ Serie 83.0 Total 0.0	40 Skott	 1: 8.7 ↖ 2: 9.6 ↖ 3: 10.0 → 4: 9.1 ← 5: 8.5 ← 6: 8.3 ↙ 7: 8.6 ← 8: 8.2 ↗ 9: 10.4x ↘ 10: 9.0 → Serie 87.0 Total 87.0
40 Skott		11: 6.2 → 12: 9.6 ↗ 13: 9.9 ↖ 14: 6.1 → 15: 7.8 ↗ 16: 8.7 → 17: 10.5x ↘ 18: 9.8 ↖ 19: 8.6 → 20: 6.7 → Serie 78.0 Total 165.0	40 Skott	 21: 10.5x ↗ 22: 10.2x ↗ 23: 10.3x → 24: 9.4 → 25: 8.4 ↗ 26: 7.4 → 27: 8.0 ↗ 28: 10.6x ↘ 29: 8.8 ↗ 30: 8.3 ↗ Serie 88.0 Total 253.0
40 Skott		31: 6.5 → 32: 9.1 ↗ 33: 10.1 ↖ 34: 8.9 → 35: 8.2 ↙ 36: 8.5 ↘ 37: 9.3 ↗ 38: 8.8 ↗ 39: 10.5x ↘ 40: 8.9 ↗ Serie 84.0 Total 337.0		

Skjutlag	Tavla	Oliver Eklund	
1	16		
Vindeln	Ramselefors	9	Vb
28.01.2017	Förbundsmästerskap 2017	Ramselefors SKF	
Prov 	1: 7.1 → 2: 8.8 → 3: 8.3 → 4: 8.7 ↘ 5: 7.9 → 6: 10.5x ↘ 7: 9.9 → 8: 9.2 ↘ 9: 10.0 ↗ 10: 9.1 →	Prov 	11: 9.6 ↘ 12: 8.0 ↗ 13: 8.4 ↗ 14: 7.5 ↙ 15: 10.3x → 16: 10.0 ↑ 17: 9.2 → 18: 10.5x ↘ 19: 9.7 ↗ 20: 10.4x ↘
	Serie 85.0		Serie 90.0
	Total 0.0		Total 0.0
Prov 	21: 9.5 ↘ 22: 9.7 ↗ 23: 9.9 ↘ 24: 10.4x ← 25: 10.6x ↑	40 Skott 	1: 9.9 ↘ 2: 8.7 → 3: 8.6 ↑ 4: 9.4 ↗ 5: 9.3 ↘ 6: 10.1 → 7: 9.0 ↘ 8: 10.2x ↘ 9: 9.8 ↘ 10: 10.4x ↗
	Serie 47.0		Serie 91.0
	Total 0.0		Total 91.0
40 Skott 	11: 9.7 ↘ 12: 9.7 ↙ 13: 9.4 ↗ 14: 10.1 ↗ 15: 9.7 ↙ 16: 9.9 ↗ 17: 8.4 ↗ 18: 10.0 ↗ 19: 9.9 ↙ 20: 10.2x ↗	40 Skott 	21: 9.8 ↘ 22: 8.9 ↗ 23: 10.0 → 24: 10.1 ↗ 25: 9.9 ↗ 26: 8.7 ← 27: 9.0 ↗ 28: 9.3 ↗ 29: 9.8 ↗ 30: 9.0 ↗
	Serie 92.0		Serie 90.0
	Total 183.0		Total 273.0
40 Skott 	31: 10.1 ↗ 32: 7.8 ↙ 33: 10.2x ↗ 34: 9.4 ↙ 35: 10.5x ↘ 36: 9.5 ↘ 37: 9.8 ↘ 38: 9.4 ↗ 39: 7.5 ↘ 40: 9.8 ↗		
	Serie 89.0		
	Total 362.0		

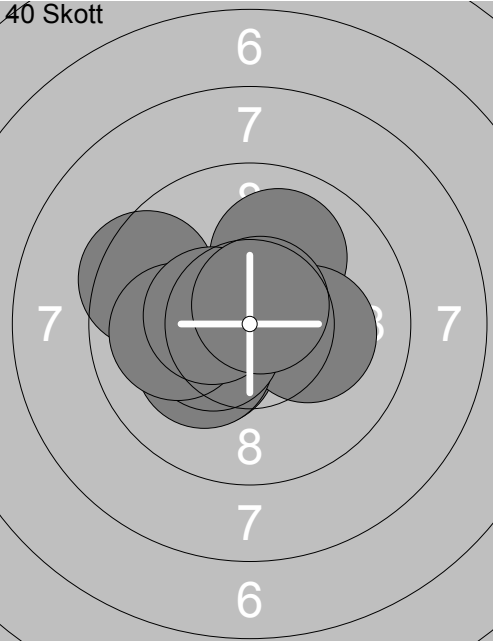
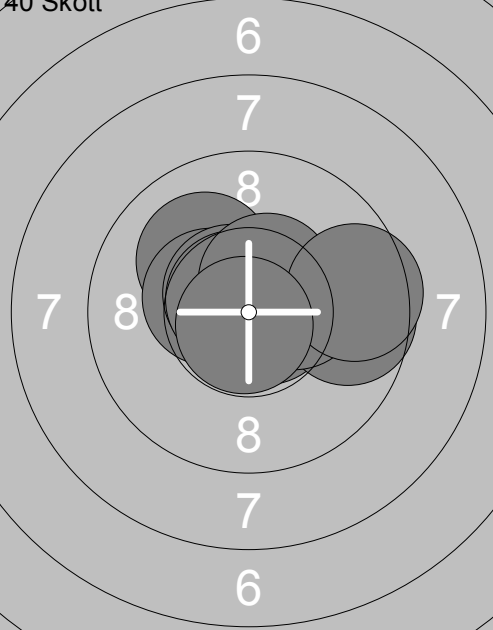
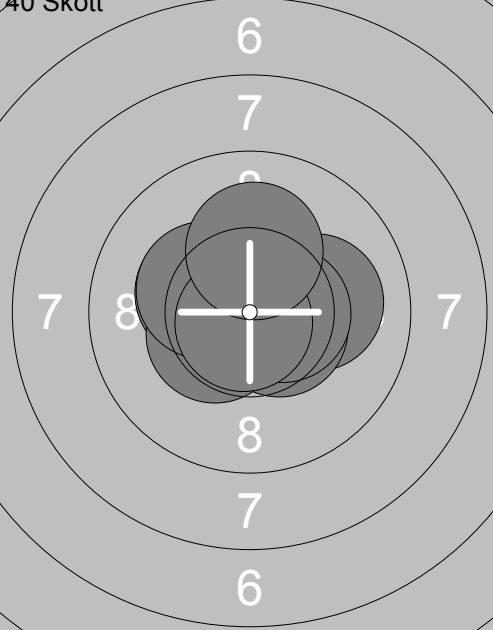
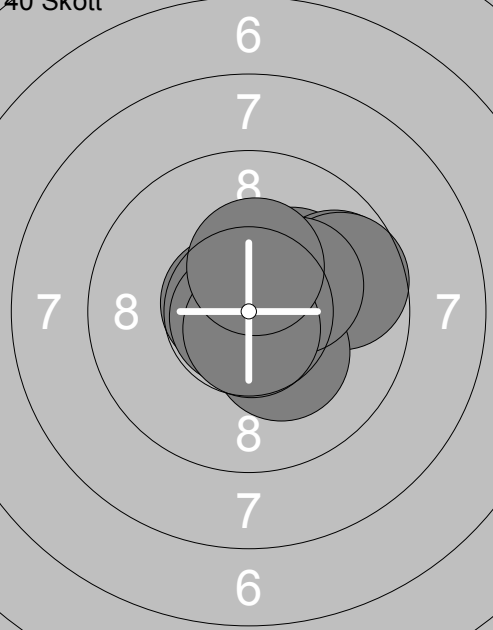

Skjutlag	Tavla	Vilhelm Lundstedt		
1	17	Ramselefors	9	Vb
28.01.2017	Föbunds mästerskap 2017	Ramselefors SKF		
	1: 10.7x ↗		1: 10.0 ↗	
	2: 10.6x ↘		2: 10.2x ↘	
	3: 10.9x ↘		3: 10.7x ↘	
	Serie 30.0		Serie 99.0	
	Total 0.0		Total 99.0	
	11: 10.1 ↘		21: 10.3x ↘	
	12: 10.7x ➤		22: 10.1 ➔	
	13: 10.4x ↘		23: 10.6x ↖	
	14: 9.7 ➔		24: 10.5x ↘	
	15: 10.6x ↘		25: 10.7x ➤	
	16: 10.7x ↘		26: 10.5x ➤	
	17: 10.3x ➤		27: 10.4x ↘	
	18: 10.5x ↗		28: 10.3x ↘	
	19: 9.5 ➔		29: 10.8x ↘	
	20: 10.8x ↘		30: 10.2x ↗	
	Serie 98.0		Serie 100.0	
	Total 197.0		Total 297.0	
	31: 10.7x ↘			
	32: 10.8x ↘			
	33: 10.2x ↗			
	34: 9.8 ➔			
	35: 10.8x ↘			
	36: 9.7 ➔			
	37: 10.3x ↘			
	38: 10.3x ➤			
	39: 10.7x ↘			
	40: 10.4x ↗			
	Serie 98.0			
	Total 395.0			

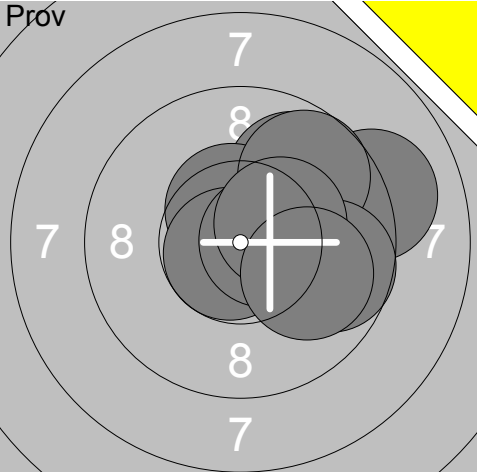
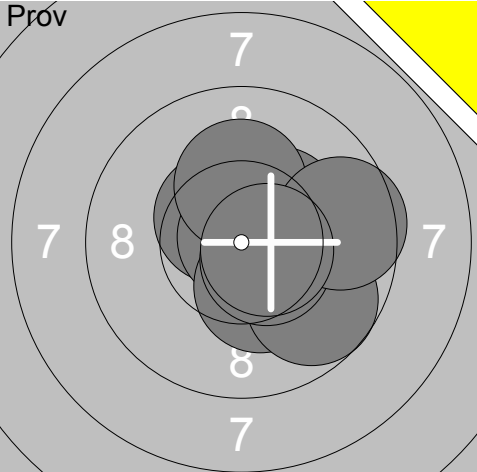
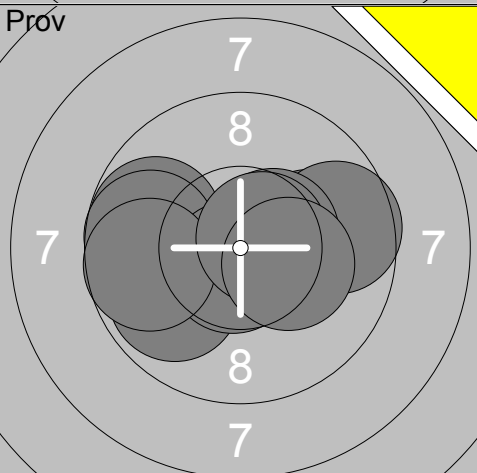
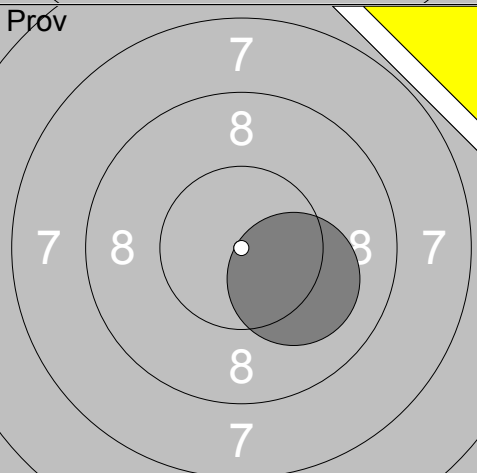
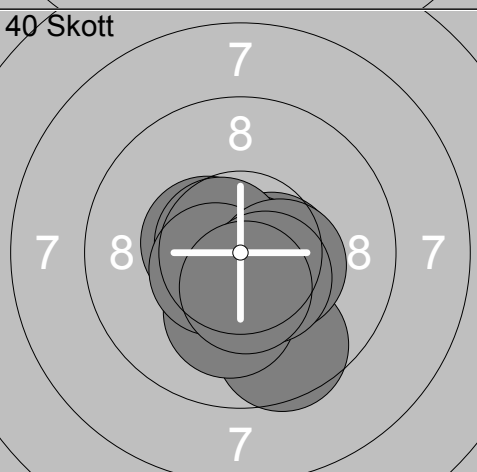
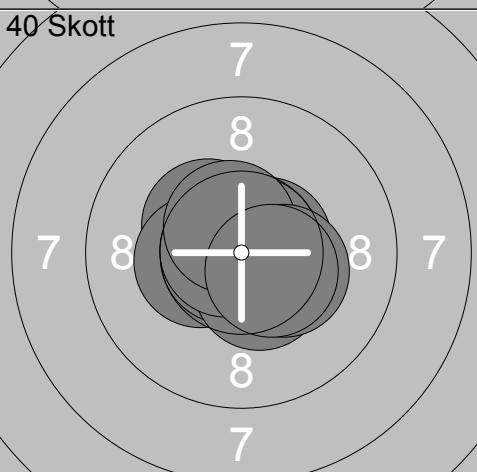
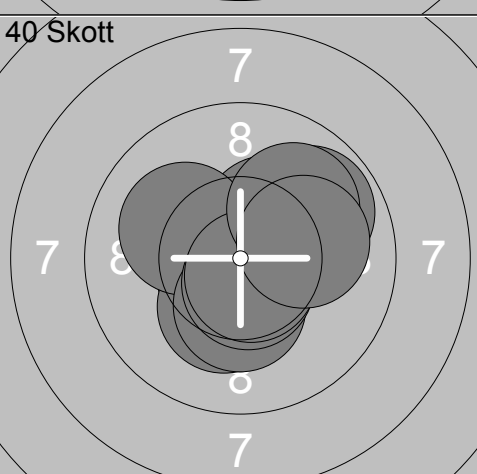
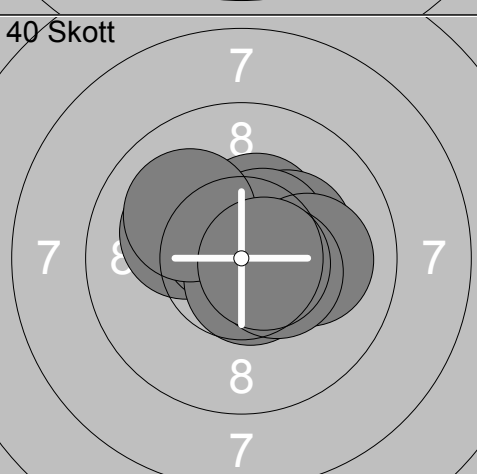
<p>Prov</p>	<p>1: 9.9 ↗ 2: 10.4x↘ 3: 10.4x↗ 4: 10.9x↘ 5: 10.7x↘ 6: 9.9 ← 7: 10.6x↗ 8: 10.7x↘ 9: 10.6x↘ 10: 10.7x↗</p> <p>Serie 98.0 Total 0.0</p>	<p>Prov</p>	<p>11: 10.2x↘ 12: 10.1 ← 13: 10.7x→ 14: 10.6x↘</p> <p>Serie 40.0 Total 0.0</p>
<p>40 Skott</p>	<p>1: 10.3x↘ 2: 10.1 ↗ 3: 10.4x↘ 4: 10.1 ← 5: 10.6x→ 6: 10.8x↘ 7: 10.4x↗ 8: 10.5x→ 9: 10.5x↘ 10: 10.8x↘</p> <p>Serie 100.0 Total 100.0</p>	<p>40 Skott</p>	<p>11: 10.2x↘ 12: 10.3x↗ 13: 10.4x→ 14: 10.0 ← 15: 10.4x↗ 16: 9.9 ← 17: 10.2x↗ 18: 10.5x↗ 19: 10.9x↗ 20: 10.5x↗</p> <p>Serie 99.0 Total 199.0</p>
<p>40 Skott</p>	<p>21: 10.7x→ 22: 10.5x→ 23: 10.5x↗ 24: 10.7x↗ 25: 10.7x↘ 26: 10.4x↗ 27: 10.8x↘ 28: 10.9x↘ 29: 10.8x↘ 30: 10.6x↘</p> <p>Serie 100.0 Total 299.0</p>	<p>40 Skott</p>	<p>31: 10.3x↗ 32: 10.9x↘ 33: 10.9x↗ 34: 10.6x↗ 35: 10.8x↗ 36: 10.2x↗ 37: 10.9x↗ 38: 10.8x↗ 39: 10.2x→ 40: 10.7x↘</p> <p>Serie 100.0 Total 399.0</p>

Skjutlag	Tavla	Ebba Lundstedt		
1	19			
Vindeln	Ramselefors	11	Vb	
28.01.2017	Förbundsmästerskap 2017	Ramselefors SKF		
Prov 	1: 9.9 ↗	Prov 	11: 10.3x ↗	
	2: 9.8 ↗		12: 10.5x ↗	
	3: 10.5x ↑		13: 10.9x ↑	
	4: 10.7x ↙		14: 10.1 →	
	5: 9.1 →		15: 10.2x ↑	
	6: 9.7 ↗		16: 10.3x ↘	
	7: 10.6x →		17: 9.7 ↘	
	8: 9.7 →		18: 10.5x ↘	
	9: 10.4x →		19: 9.6 →	
	10: 10.0 ↘		20: 10.6x ↘	
	Serie 95.0		Serie 98.0	
	Total 0.0		Total 0.0	
Prov 	21: 10.0 →	Prov 	31: 10.1 ↘	
	22: 9.9 ↙			
	23: 9.8 ↙			
	24: 9.7 ↙			
	25: 10.7x ↘			
	26: 9.7 ↙			
	27: 9.6 →			
	28: 10.5x →			
	29: 10.6x →			
	30: 10.3x →			
	Serie 95.0		Serie 10.0	
	Total 0.0		Total 0.0	
40 Skott 	1: 10.5x ↙	40 Skott 	11: 10.6x →	
	2: 10.5x →		12: 10.4x ↗	
	3: 9.6 ↘		13: 10.4x ↙	
	4: 10.8x ↘		14: 10.7x ↗	
	5: 10.1 ↘		15: 10.8x ↙	
	6: 10.7x ↗		16: 10.5x ↘	
	7: 10.5x ↙		17: 10.7x ↙	
	8: 10.4x →		18: 10.6x ↗	
	9: 10.5x ↘		19: 10.3x ↘	
	10: 10.5x ↘		20: 10.5x ↘	
	Serie 99.0		Serie 100.0	
	Total 99.0		Total 199.0	
40 Skott 	21: 10.7x ↙	40 Skott 	31: 10.4x ↗	
	22: 9.8 ↗		32: 10.1 ↙	
	23: 10.3x ↗		33: 10.6x ↗	
	24: 10.3x ↘		34: 10.3x →	
	25: 10.1 ↗		35: 10.6x ↘	
	26: 10.3x ↘		36: 10.5x ↗	
	27: 10.6x ↘		37: 10.1 →	
	28: 10.7x ↘		38: 10.0 ↗	
	29: 10.0 ↗		39: 10.4x →	
	30: 10.1 →		40: 10.6x →	
	Serie 99.0		Serie 100.0	
	Total 298.0		Total 398.0	

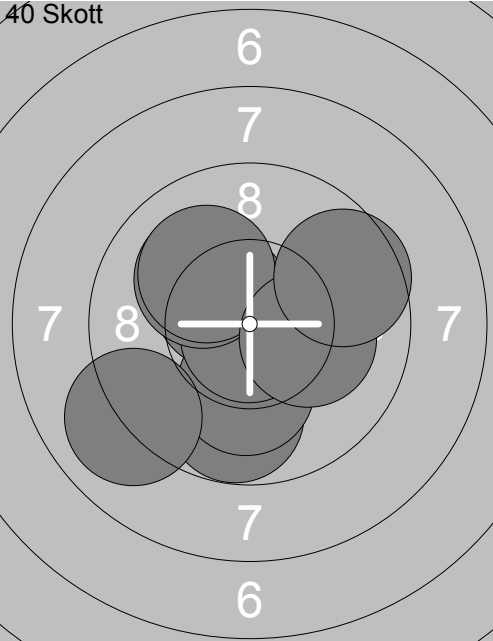
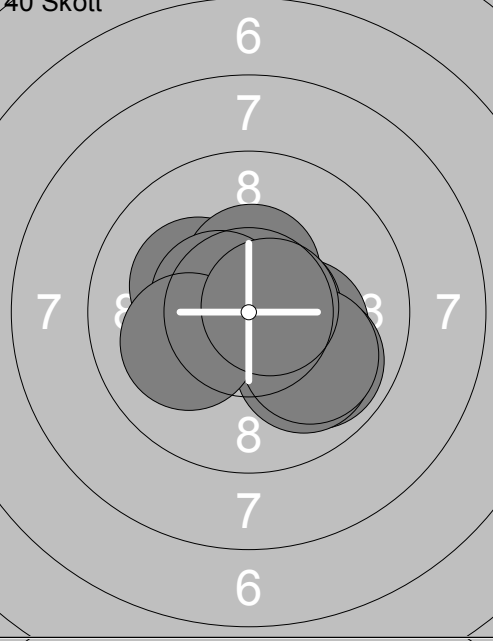
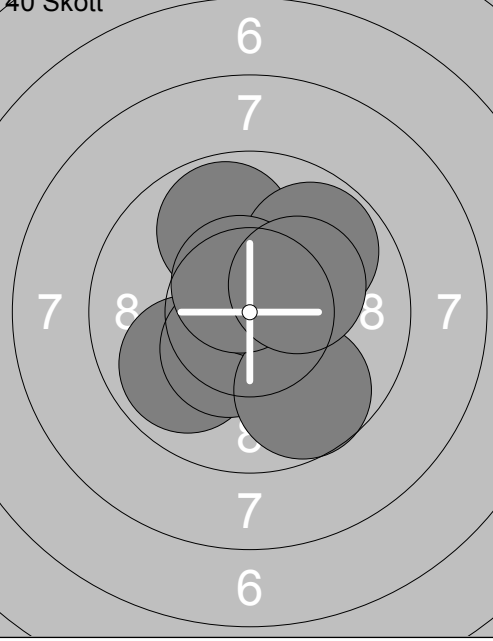
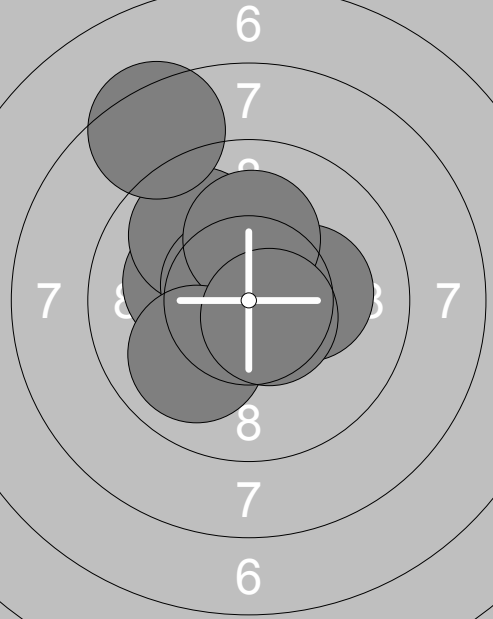
Skjutlag	Tavla	Joel Bergqvist		
1	21	Umeå	13	Vb
28.01.2017	Förbundsmästerskap 2017	Ramselefors SKF		
	1: 9.5 ↓		11: 10.8x↘	
	2: 9.7 ↓		12: 10.7x↖	
	3: 10.6x↗			
	4: 10.3x↘			
	5: 10.6x↓			
	6: 10.3x↗			
	7: 10.6x↖			
	8: 10.6x↖			
	9: 10.6x→			
	10: 10.5x↗			
Serie 98.0		Serie 20.0		
Total 0.0		Total 0.0		
	1: 10.6x↖		11: 10.4x↖	
	2: 10.7x→		12: 10.3x↖	
	3: 10.7x↖		13: 10.8x↑	
	4: 10.7x→		14: 10.6x↖	
	5: 10.6x↗		15: 10.7x↗	
	6: 10.9x↖		16: 10.7x↖	
	7: 10.2x→		17: 10.8x↓	
	8: 10.1↖		18: 10.6x↖	
	9: 10.9x→		19: 10.5x↗	
	10: 10.7x↗		20: 10.8x↓	
Serie 100.0		Serie 100.0		
Total 100.0		Total 200.0		
	21: 10.6x↖		31: 10.6x↖	
	22: 10.2x↖		32: 10.4x↖	
	23: 10.8x↖		33: 10.4x↗	
	24: 10.9x↗		34: 10.8x↑	
	25: 10.5x→		35: 10.1↖	
	26: 10.7x↗		36: 10.2x↖	
	27: 10.7x↗		37: 10.6x→	
	28: 10.6x↖		38: 10.6x↘	
	29: 10.7x↖		39: 10.2x↖	
	30: 10.4x↖		40: 10.6x↖	
Serie 100.0		Serie 100.0		
Total 300.0		Total 400.0		

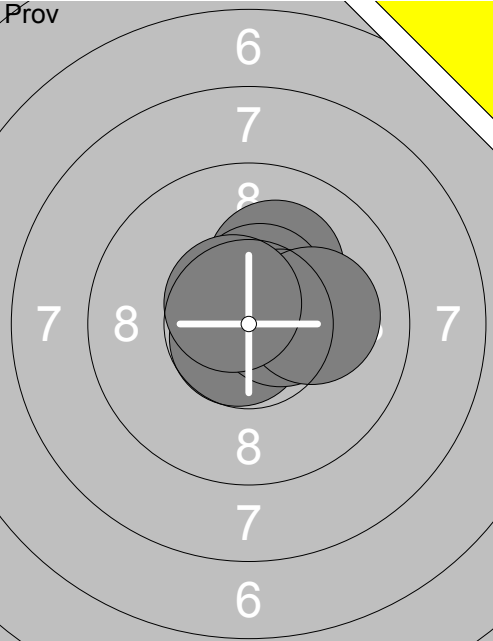
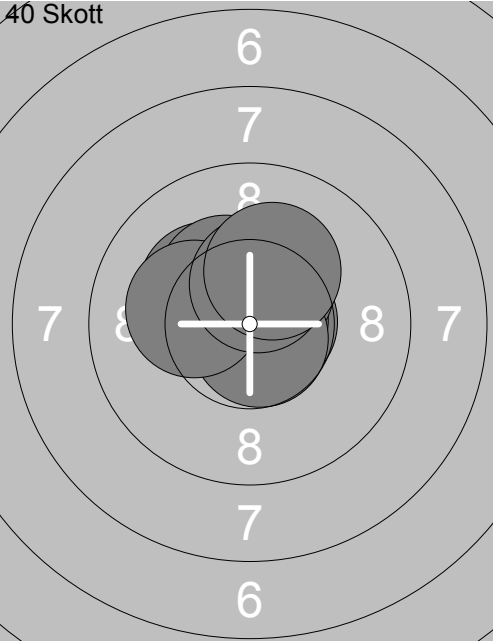
Skjutlag	Tavla	Ari-Jukka Perkiömäki			
1	23	Vindeln	Umeå	Sitt	Vb
28.01.2017		Förbundsmästerskap 2017		Ramselefors SKF	
Prov 	1: 10.5x ↘	40 Skott 	1: 10.8x ↘		
	2: 10.5x ↘		2: 9.8 ↓		
	3: 10.7x ↘		3: 10.1 ↓		
	4: 9.7 ↓		4: 10.5x ↘		
	5: 10.4x ↘		5: 10.8x ↓		
	6: 10.7x ↘		6: 10.1 ↖		
	Serie 59.0		Serie 97.0		
	Total 0.0		Total 97.0		
40 Skott 	11: 10.3x ➤	40 Skott 	21: 10.6x ➤		
	12: 10.2x ↘		22: 9.9 ↙		
	13: 9.9 ↙		23: 10.3x ↗		
	14: 10.0 ↙		24: 10.4x ↘		
	15: 10.6x ➤		25: 9.8 ↑		
	16: 10.0 ↙		26: 10.6x ↗		
	17: 10.4x ↗		27: 9.7 ↙		
	18: 10.5x ↘		28: 9.8 ↗		
	19: 10.1 ↙		29: 10.6x ↗		
	20: 10.7x ➤		30: 10.2x ➤		
	Serie 99.0		Serie 96.0		
	Total 196.0		Total 292.0		
40 Skott 	31: 10.6x ➤				
	32: 10.7x ➤				
	33: 10.2x ➤				
	34: 10.2x ↘				
	35: 9.9 ↖				
	36: 10.6x ↘				
	37: 8.4 ↖				
	38: 10.2x ↗				
	39: 10.0 ↙				
	40: 10.6x ↘				
	Serie 97.0				
	Total 389.0				

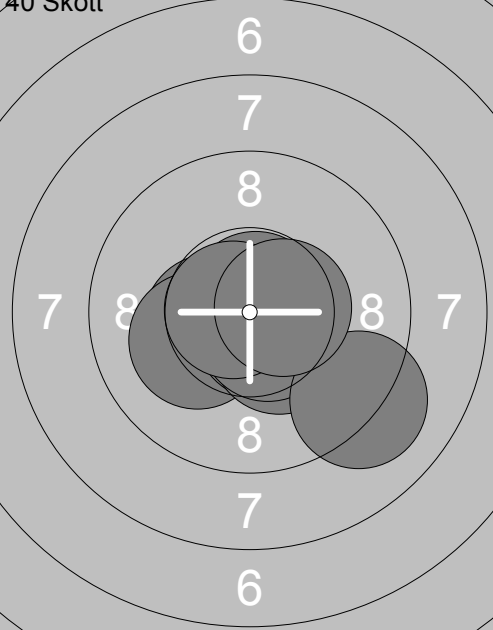
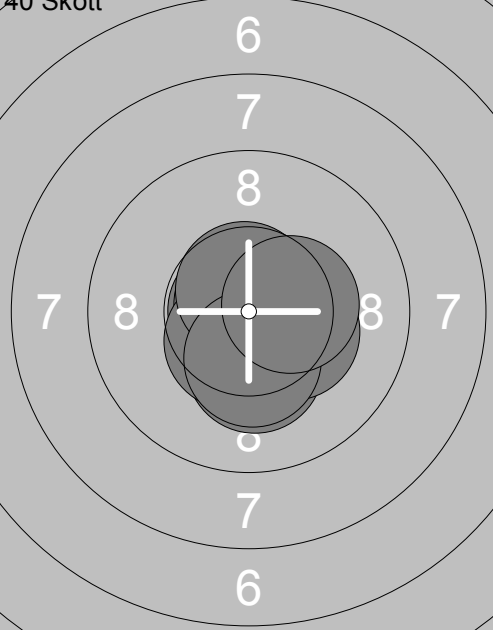
Skjutlag 1	Tavla 24	Jordan Olsson		
Vindeln	Umeå	13	Vb	
28.01.2017	Förbundsmästerskap 2017	Ramselefors SKF		
Prov		1: 10.2x↗ 2: 10.7x↘ 3: 10.5x↗ 4: 10.5x➤ 5: 10.1➔ 6: 10.6x↘	40 Skott	 1: 10.4x↘ 2: 10.7x➤ 3: 10.8x➤ 4: 10.2x↘ 5: 10.4x↗ 6: 10.7x↘ 7: 10.3x↘ 8: 10.2x↘ 9: 10.4x↗ 10: 10.2x↗
		Serie 60.0		Serie 100.0
		Total 0.0		Total 100.0
40 Skott		11: 10.8x➤ 12: 10.4x➤ 13: 10.4x↗ 14: 10.4x↗ 15: 10.7x↘ 16: 10.4x↘ 17: 10.3x↗ 18: 10.6x➤ 19: 10.4x↘ 20: 10.8x↘	40 Skott	 21: 10.4x↘ 22: 10.8x↘ 23: 10.2x↘ 24: 10.8x↗ 25: 10.6x↘ 26: 10.4x↘ 27: 10.6x↘ 28: 9.1 ↘ 29: 10.7x↘ 30: 10.5x➤
		Serie 100.0		Serie 99.0
		Total 200.0		Total 299.0
40 Skott		31: 10.8x➤ 32: 10.8x↘ 33: 10.5x↘ 34: 10.8x↘ 35: 10.2x↘ 36: 10.5x↘ 37: 10.3x➤ 38: 10.7x↗ 39: 10.3x↘ 40: 10.4x➤		
		Serie 100.0		
		Total 399.0		

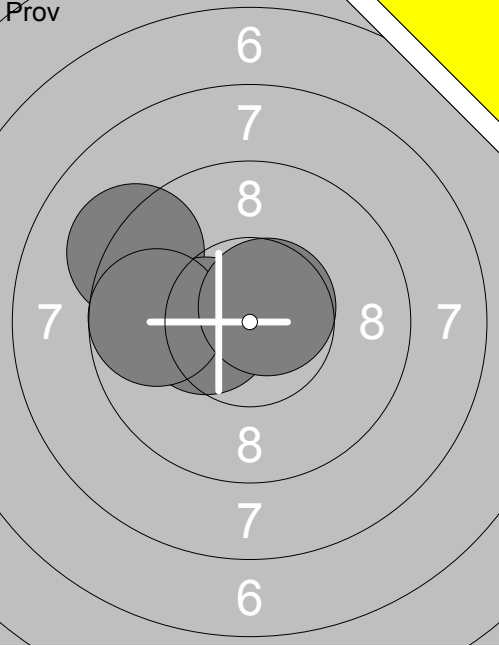
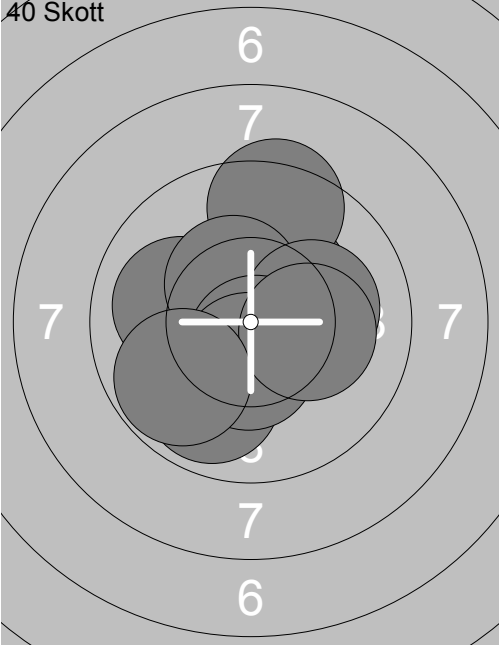
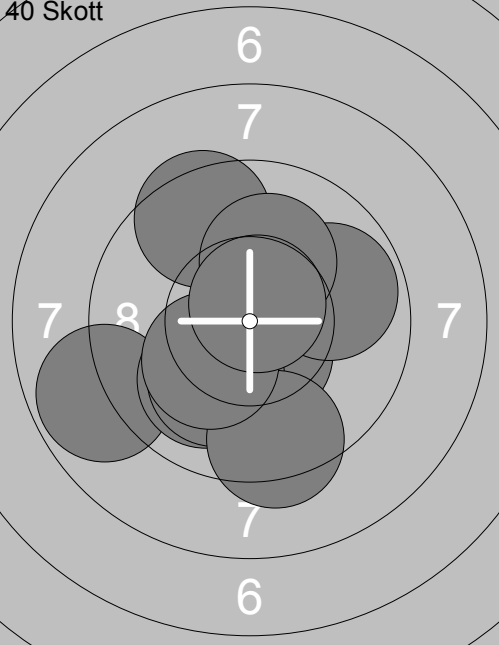
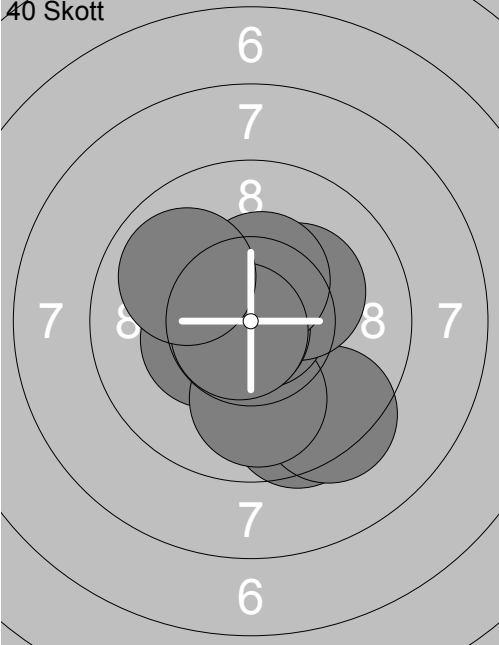
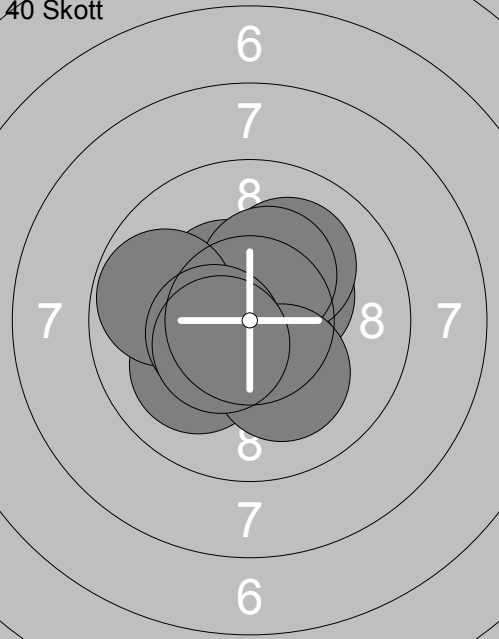
Skjutlag	Tavla	Kim Björk		
1	25			
Vindeln	Ramselefors	Sitt	Vb	
28.01.2017	Föbunds mästerskap 2017	Ramselefors SKF		
	1: 9.2 ↙ 2: 10.4x↙ 3: 9.7 ← 4: 10.6x↗		1: 10.0 ← 2: 10.3x↗ 3: 9.4 ↑ 4: 10.4x↖ 5: 10.1 → 6: 10.7x↓ 7: 9.9 ↓ 8: 10.4x↓ 9: 10.2x→ 10: 9.8 ↙	
	Serie 38.0		Serie 97.0	
	Total 0.0		Total 97.0	
	11: 10.5x↘ 12: 8.8 ← 13: 10.0 ↘ 14: 10.1 ↘ 15: 9.4 ↓ 16: 9.5 ↑ 17: 10.2x↘ 18: 9.8 → 19: 10.1 ↑ 20: 10.7x↗		21: 10.4x↙ 22: 9.5 ↓ 23: 9.4 ↘ 24: 9.9 ↓ 25: 10.8x→ 26: 10.2x↗ 27: 10.8x↙ 28: 10.4x↗ 29: 10.8x↙ 30: 9.9 ↙	
	Serie 95.0		Serie 96.0	
	Total 192.0		Total 288.0	
	31: 10.4x↗ 32: 10.1 ↙ 33: 10.3x↘ 34: 10.1 ↗ 35: 10.4x↖ 36: 10.3x↗ 37: 9.8 ← 38: 10.2x↘ 39: 10.5x↙ 40: 10.5x↙			
	Serie 99.0			
	Total 387.0			

	1: 10.0 ↑		1: 10.6x ↘
	2: 9.9 ←		2: 10.3x ↘
	3: 10.5x ↑		3: 10.3x ↘
	4: 10.9x ↑		4: 10.1 ←
	5: 10.6x ↑		5: 10.2x ↑
	6: 10.0 ←		6: 9.4 ←
	7: 9.9 ←		7: 10.5x ↑
	8: 10.3x ↑		8: 9.9 ↗
	9: 10.3x ↘		9: 10.4x ↘
	10: 10.3x ↘		10: 9.1 ↓
Serie 98.0		Serie 97.0	
Total 0.0		Total 97.0	

	11: 10.7x ↘		21: 10.7x ↑
	12: 10.6x ↘		22: 10.8x ↘
	13: 10.6x ↘		23: 10.5x ↑
	14: 10.5x ↘		24: 10.3x ↗
	15: 10.0 ←		25: 10.7x ↘
	16: 10.6x ↑		26: 10.8x ↘
	17: 10.8x ↑		27: 9.8 ↗
	18: 10.8x ↗		28: 10.6x ↘
	19: 10.5x ↘		29: 10.8x ↗
	20: 10.2x ↘		30: 10.3x ↑
Serie 100.0		Serie 99.0	
Total 197.0		Total 296.0	

	31: 10.7x ↗		
	32: 10.5x ↘		
	33: 9.8 ↗		
	34: 10.1 ↗		
	35: 10.0 ↓		
	36: 9.2 ↘		
	37: 10.3x ↑		
	38: 10.7x ↘		
	39: 10.0 ↗		
	40: 10.2x ↑		
Serie 98.0			
Total 394.0			

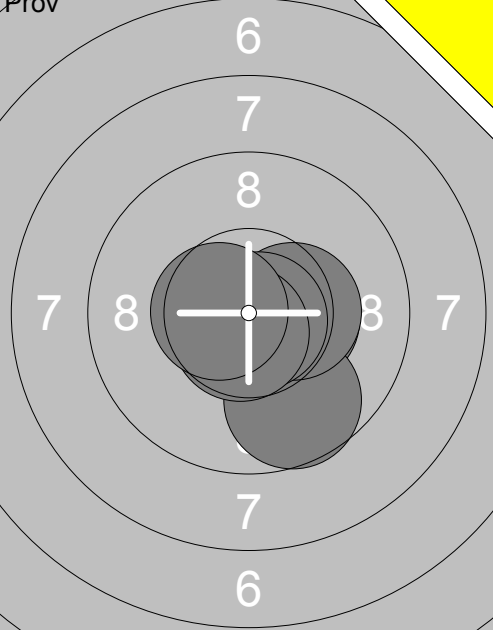
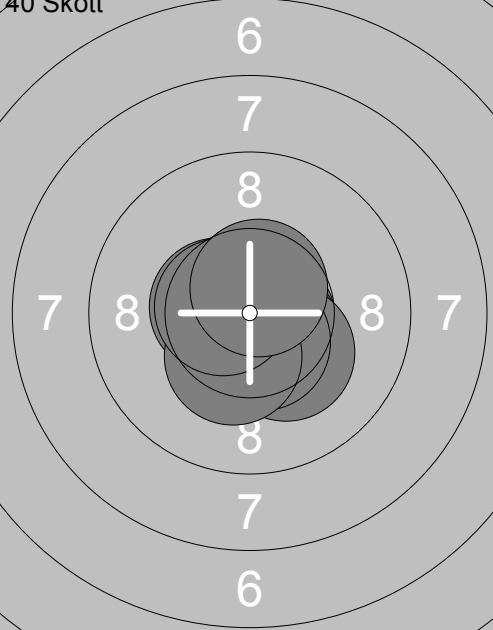
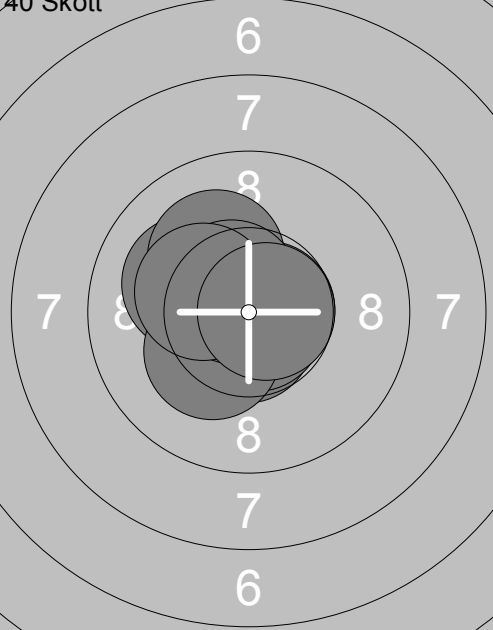
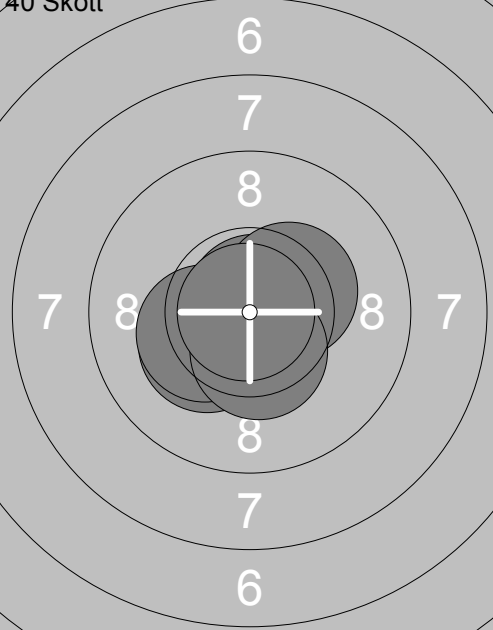
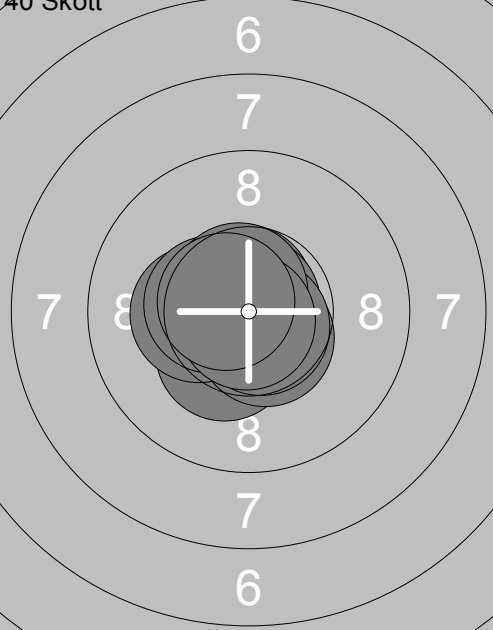
<p>Prov</p>  <p style="text-align: center;">6 7 8 7 8 8 7 7 6</p>	<p>1: 10.4x➤</p> <p>2: 10.8x↓</p> <p>3: 9.7 ↓</p> <p>4: 10.4x➤</p> <p>5: 10.8x↘</p> <p>6: 10.7x↓</p> <p>7: 10.6x↙</p>	<p>40 Skott</p>  <p style="text-align: center;">6 7 8 7 8 8 7 7 6</p> <p>8: 10.7x↘</p> <p>9: 10.5x↓</p> <p>10: 10.6x↗</p>
Serie 69.0		Serie 100.0
Total 0.0		Total 100.0
<p>40 Skott</p>  <p style="text-align: center;">6 7 8 7 8 8 7 7 6</p>	<p>11: 10.1↙</p> <p>12: 10.7x↓</p> <p>13: 10.8x↓</p> <p>14: 10.3x↙</p> <p>15: 10.7x➤</p> <p>16: 10.1 ↖</p> <p>17: 10.7x↘</p> <p>18: 10.6x↘</p> <p>19: 10.3x↙</p> <p>20: 10.7x➤</p>	<p>40 Skott</p>  <p style="text-align: center;">6 7 8 7 8 8 7 7 6</p> <p>21: 10.7x↙</p> <p>22: 10.7x↓</p> <p>23: 10.8x↗</p> <p>24: 10.4x➤</p> <p>25: 10.3x↙</p> <p>26: 10.7x↙</p> <p>27: 10.8x↓</p> <p>28: 10.3x↙</p> <p>29: 10.4x↓</p> <p>30: 10.9x↙</p>
Serie 100.0		Serie 100.0
Total 200.0		Total 300.0
<p>40 Skott</p>  <p style="text-align: center;">6 7 8 7 8 8 7 7 6</p>	<p>31: 10.3x↓</p> <p>32: 10.5x↓</p> <p>33: 10.7x↗</p> <p>34: 10.3x↙</p> <p>35: 10.8x↗</p> <p>36: 10.7x↓</p> <p>37: 10.5x↙</p> <p>38: 10.7x↘</p> <p>39: 10.8x↓</p> <p>40: 10.6x↙</p>	
Serie 100.0		
Total 400.0		

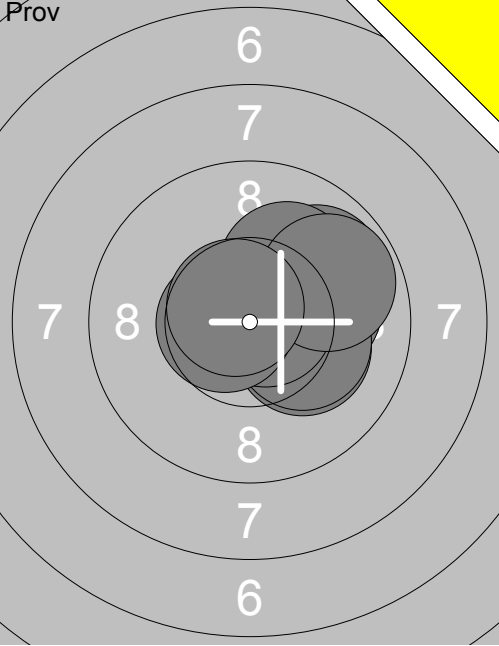
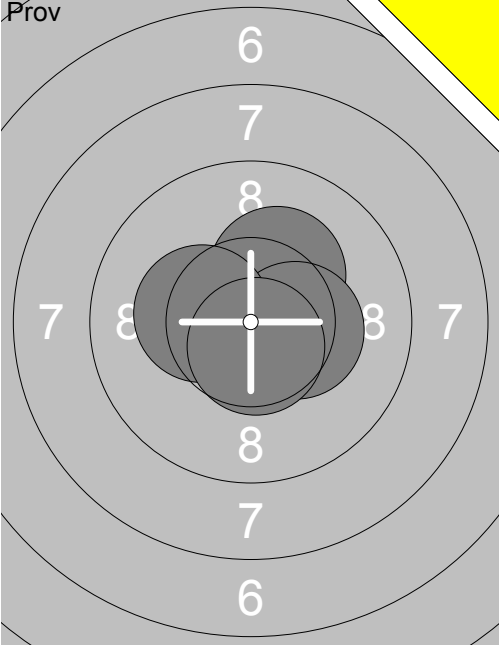
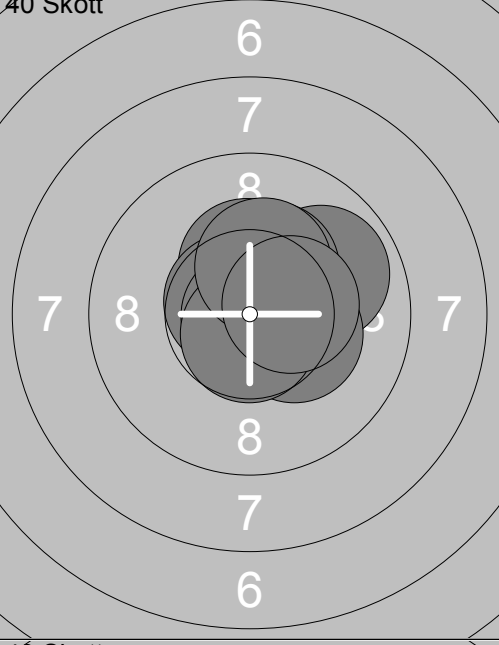
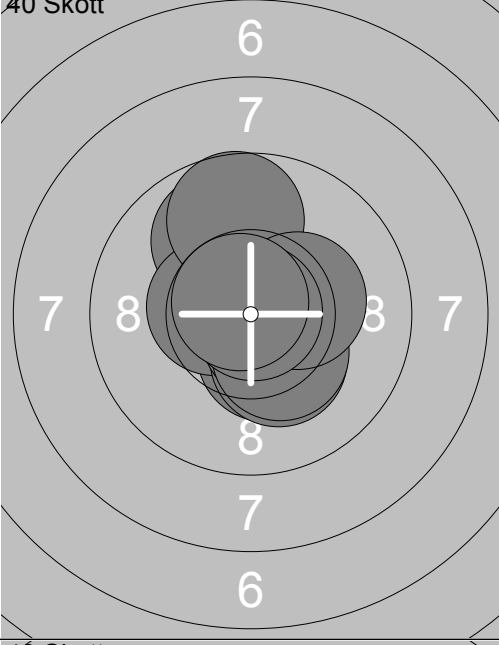
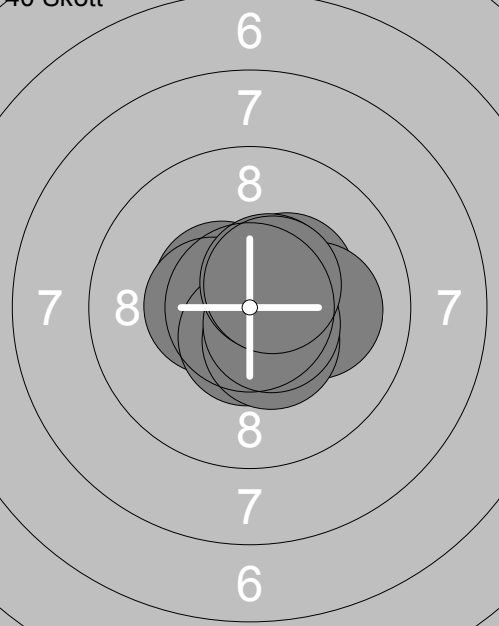
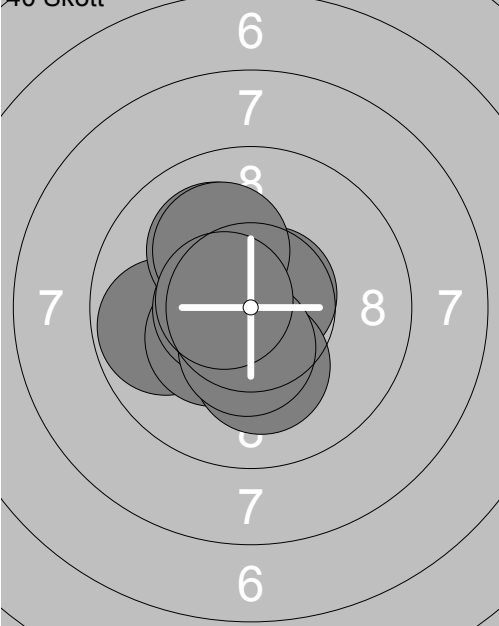

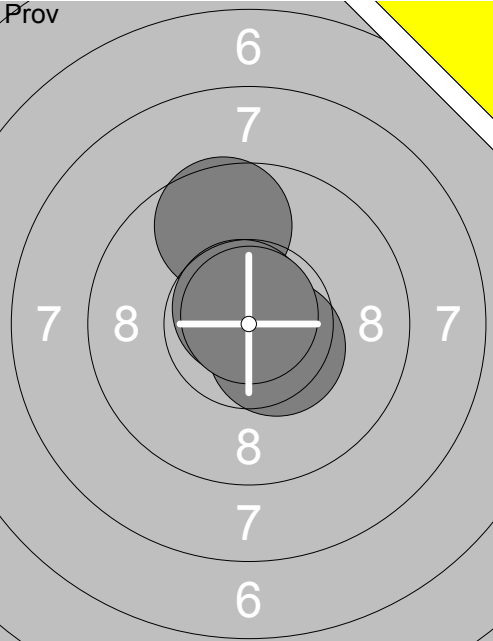
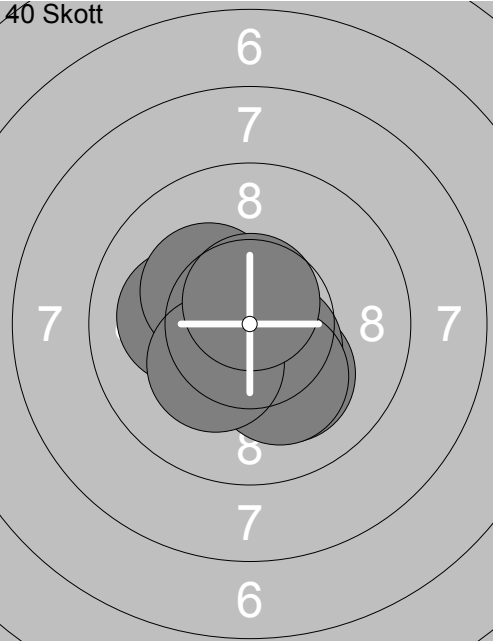
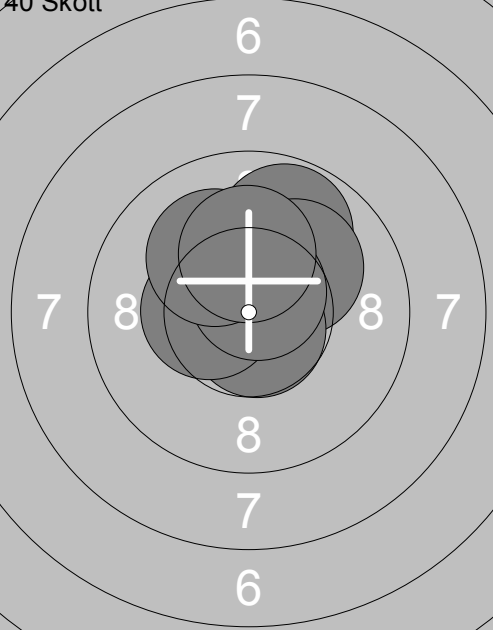
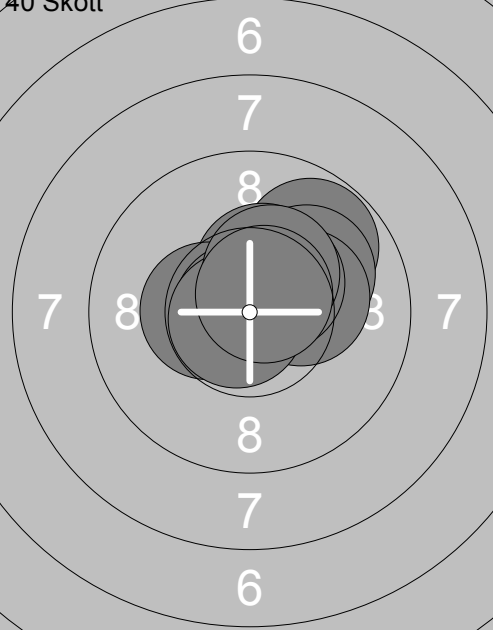
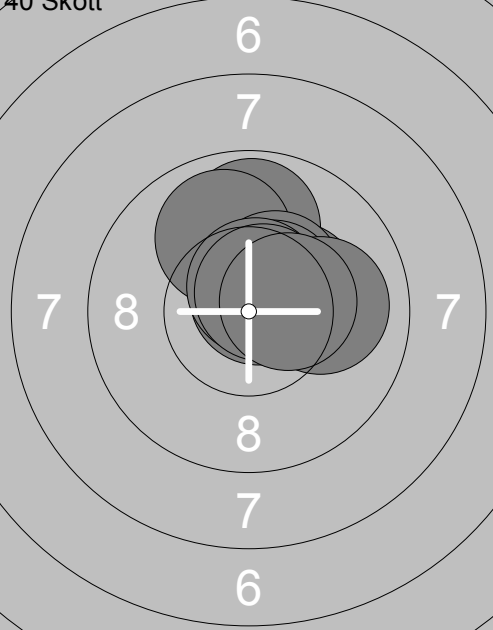
Skjutlag	Tavla	Sofi Jonsson		Sitt	Vb
1	28				
Vindeln	Ramselefors				
28.01.2017	Förbundsmästerskap 2017	Ramselefors SKF			
Prov			Prov		
	1: 9.9 ↗ 2: 10.3x↗ 3: 10.1 → 4: 10.2x↘ 5: 10.2x↘ 6: 10.7x↗ 7: 10.1 ↗ 8: 10.6x← 9: 9.8 ↗ 10: 10.7x↘		11: 10.2x↗ 12: 10.4x↘ 13: 10.3x← 14: 10.6x↘		
	Serie 98.0 Total 0.0		Serie 40.0 Total 0.0		
40 Skott			40 Skott		
	1: 10.7x↗ 2: 9.9 ↗ 3: 10.3x↗ 4: 10.3x↗ 5: 10.7x↘ 6: 10.3x↘ 7: 10.9x↘ 8: 10.7x↘ 9: 10.3x↗ 10: 10.4x↘		11: 9.9 ↗ 12: 10.4x↘ 13: 10.5x← 14: 10.3x↘ 15: 10.6x↘ 16: 9.7 ↑ 17: 10.3x↘ 18: 10.3x↘ 19: 10.9x↗ 20: 10.7x↘		
	Serie 99.0 Total 99.0		Serie 98.0 Total 197.0		
40 Skott			40 Skott		
	21: 10.4x↗ 22: 10.5x← 23: 10.5x↘ 24: 10.5x← 25: 10.1 → 26: 10.6x↘ 27: 10.4x↘ 28: 10.6x↘ 29: 10.5x↗ 30: 10.5x↗		31: 10.7x↗ 32: 9.8 ← 33: 10.3x← 34: 10.6x← 35: 10.1 ↗ 36: 10.7x↗ 37: 10.2x↘ 38: 10.1 ↗ 39: 10.4x↘ 40: 10.6x←		
	Serie 100.0 Total 297.0		Serie 99.0 Total 396.0		

Skjutlag	Tavla	Niklas Johansson	
1	29	Vindeln	Vännäs
28.01.2017	Förbundsmästerskap 2017	Sitt	Vb
Prov		Ramselefors SKF	
	1: 9.6 ↑ 2: 10.7x ↘ 3: 10.5x ↘ 4: 10.8x ↑	40 Skott 	1: 10.7x ↘ 2: 10.1 ↓ 3: 10.5x ↘ 4: 10.1 ← 5: 10.5x ↘ 6: 10.7x ↘ 7: 10.3x ↘ 8: 10.2x ↓ 9: 10.3x ↘ 10: 10.7x ↑
	Serie 39.0		Serie 100.0
	Total 0.0		Total 100.0
40 Skott 	11: 10.6x ↘ 12: 9.8 ↑ 13: 10.6x ↗ 14: 10.4x ↗ 15: 10.1 ↗ 16: 10.7x ↓ 17: 10.4x ↘ 18: 10.7x ↗ 19: 10.1 ↘ 20: 10.2x ↑	40 Skott 	21: 9.8 ↗ 22: 10.4x ↗ 23: 10.1 ↗ 24: 10.3x → 25: 10.4x ↘ 26: 10.4x ↗ 27: 10.9x ↘ 28: 10.8x ↘ 29: 10.4x ↗ 30: 10.7x ↗
	Serie 99.0		Serie 99.0
	Total 199.0		Total 298.0
40 Skott 	31: 9.9 ↑ 32: 10.3x → 33: 9.9 ↑ 34: 10.7x ↗ 35: 10.4x ↗ 36: 10.5x ↗ 37: 10.0 → 38: 10.6x ↗ 39: 10.6x ↗ 40: 10.4x →		
	Serie 98.0		
	Total 396.0		

Skjutlag	Tavla	Ida Lundmark	
2	1		
Vindeln	Drängsmark	Sen	Vb
28.01.2017	Föbunds mästerskap 2017	Ramselefors SKF	
	1: 10.4x → 2: 9.6 → 3: 9.5 ← 4: 9.8 → 5: 10.0 ↓ 6: 9.1 ↓ 7: 8.7 ← 8: 9.3 ← 9: 9.3 → 10: 9.8 ↖ Serie 91.0 Total 0.0		11: 10.4x ↑ 12: 9.7 → 13: 10.2x ↘ 14: 10.2x ↓ 15: 10.4x ↘ Serie 49.0 Total 0.0
	1: 9.6 ↖ 2: 10.3x ↘ 3: 10.7x ↘ 4: 10.0 ↗ 5: 10.3x ↓ 6: 9.6 ↗ 7: 8.2 ← 8: 8.9 ← 9: 9.7 ↖ 10: 9.3 → Serie 92.0 Total 92.0		11: 8.7 ↘ 12: 9.2 ↘ 13: 8.6 ↖ 14: 8.3 ↗ 15: 10.5x ↑ 16: 9.9 ↗ 17: 9.5 ↑ 18: 10.8x ↑ 19: 9.0 ↖ 20: 10.7x ↓ Serie 90.0 Total 182.0
	21: 10.6x ↗ 22: 8.3 ↗ 23: 10.1 ↖ 24: 10.2x ↖ 25: 9.1 ↗ 26: 9.7 ↖ 27: 8.8 ← 28: 8.8 → 29: 9.7 ↓ 30: 9.4 ↑ Serie 90.0 Total 272.0		31: 8.6 ← 32: 9.5 ↖ 33: 9.4 ← 34: 8.6 ↗ 35: 9.6 ↑ 36: 9.2 → 37: 9.1 ↗ 38: 9.7 ↖ 39: 9.6 ↑ 40: 9.3 ← Serie 88.0 Total 360.0

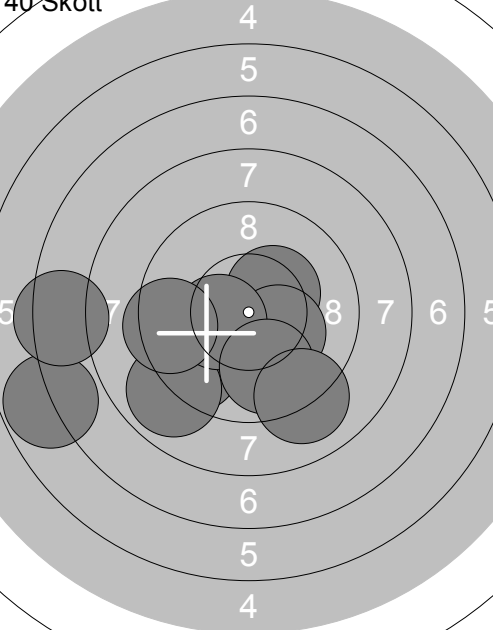
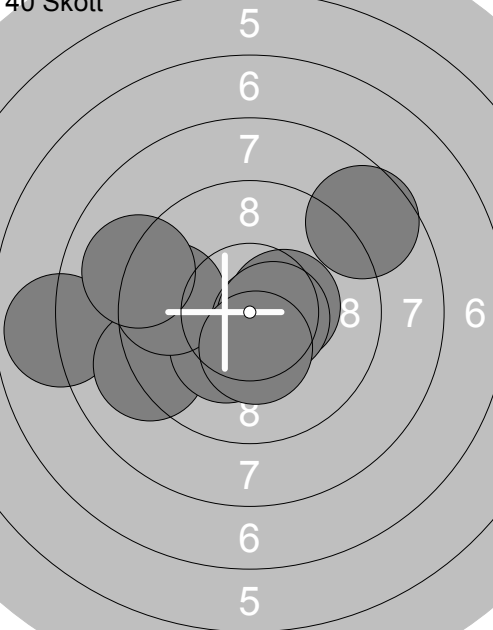
 <p>Prov</p>	<p>40 Skott</p> 	<p>1: 6.9 ↓</p> <p>2: 8.9 ←</p> <p>3: 8.5 ↗</p> <p>4: 9.8 ↓</p> <p>5: 8.7 ↓</p> <p>6: 9.0 ←</p> <p>7: 10.5x↗</p>
Serie 58.0	Serie 94.0	
Total 0.0	Total 94.0	

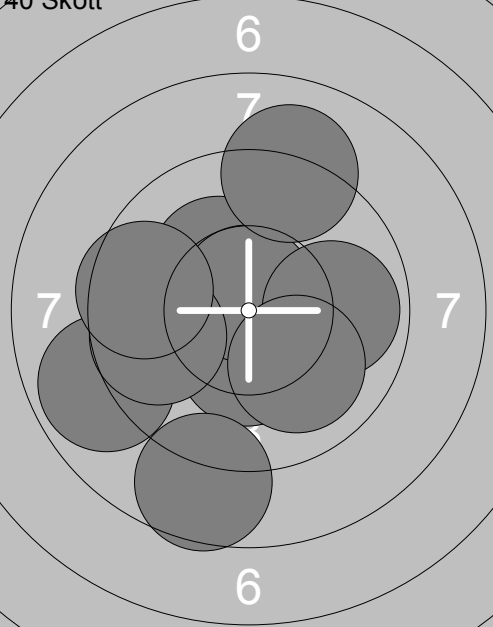
 <p>40 Skott</p>	<p>40 Skott</p> 	<p>11: 10.4x↗</p> <p>12: 9.5 ↓</p> <p>13: 6.8 ←</p> <p>14: 10.3x↘</p> <p>15: 8.9 ↓</p> <p>16: 10.4x←</p> <p>17: 9.9 ↓</p> <p>18: 9.1 ↓</p> <p>19: 7.4 ←</p> <p>20: 9.4 ←</p>
Serie 87.0	Serie 92.0	
Total 181.0	Total 273.0	

 <p>40 Skott</p>		<p>31: 10.3x↓</p> <p>32: 10.2x↘</p> <p>33: 8.6 ↓</p> <p>34: 10.7x↑</p> <p>35: 9.9 →</p> <p>36: 8.9 ←</p> <p>37: 10.0 ↓</p> <p>38: 9.7 ←</p> <p>39: 9.1 ↑</p> <p>40: 9.6 ←</p>
Serie 92.0		
Total 365.0		

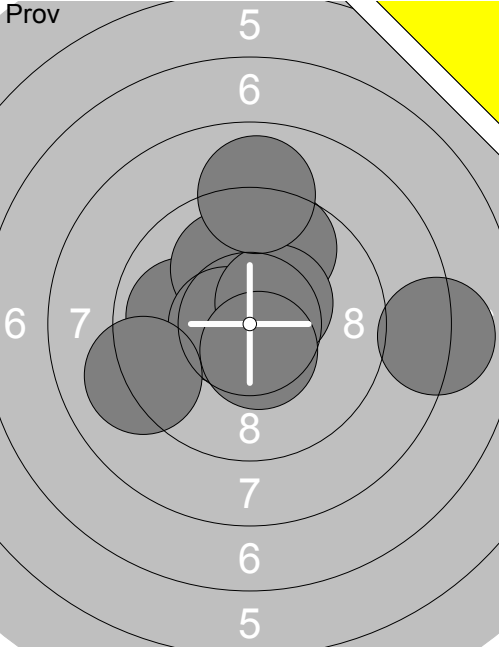
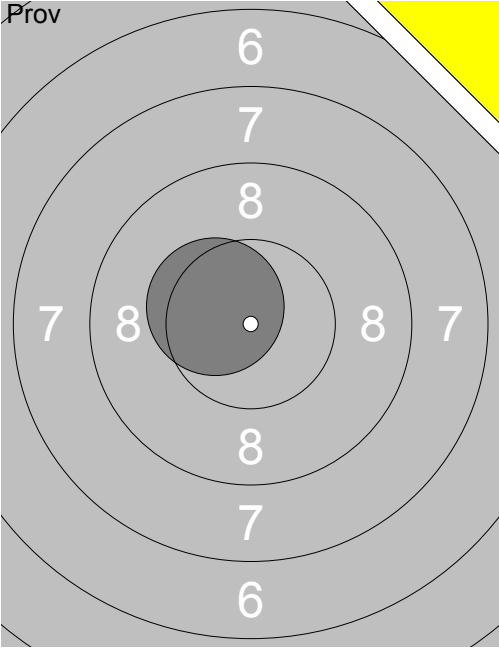
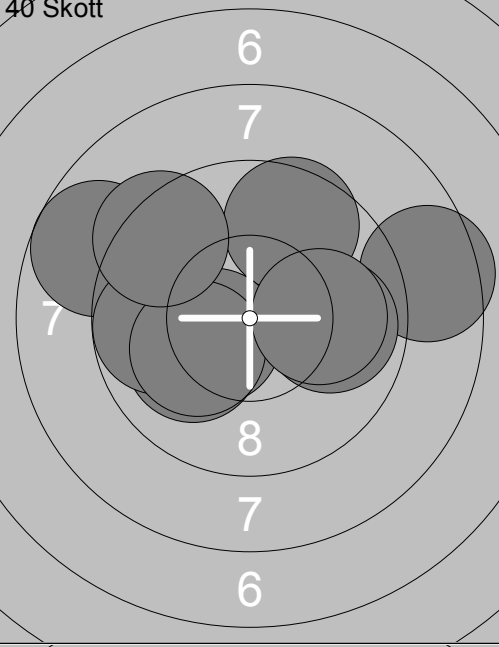
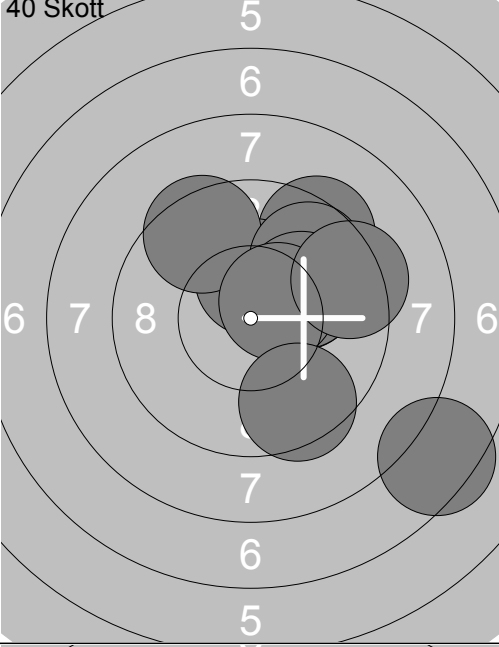
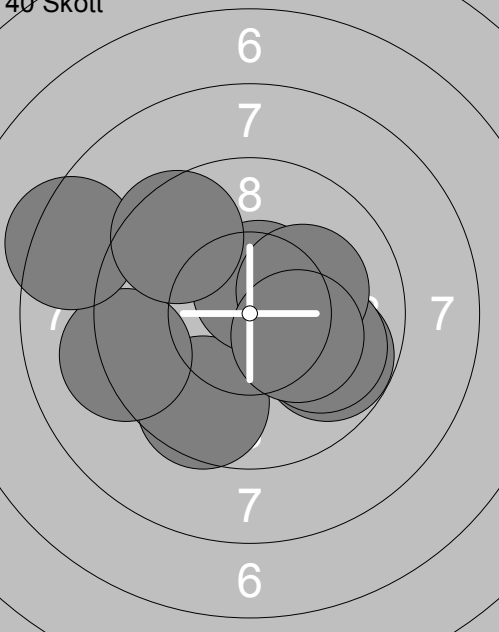
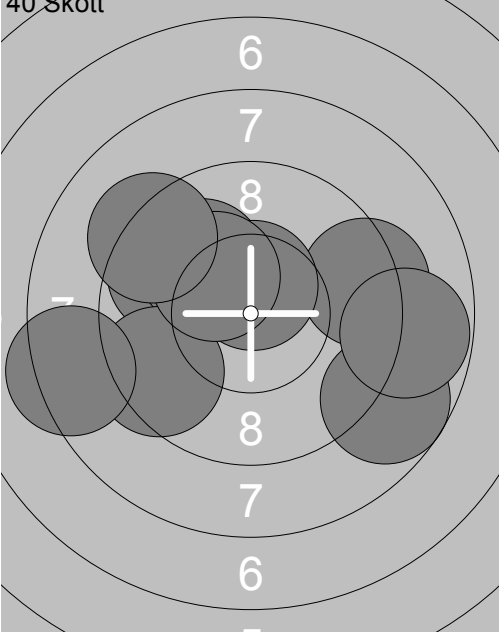
Skjutlag	Tavla	Emilia Nordin												
2	3	Vindeln	Umeå	Jun	Vb									
28.01.2017		Förbundsmästerskap 2017		Ramselefors SKF										
Prov		1: 9.9 ←	2: 10.8x↓	3: 9.7 ↑	4: 10.0 ↑	5: 10.6x←	6: 8.1 →	7: 10.5x↗	8: 9.0 ↑	9: 10.5x↓	10: 9.1 ←	Prov		11: 10.4x↖
		Serie 94.0		Serie 10.0										
		Total 0.0		Total 0.0										
40 Skott		1: 9.6 ↑	2: 10.4x↖	3: 8.5 →	4: 10.1↖	5: 8.7 ↖	6: 9.9 →	7: 9.8 ←	8: 10.1↖	9: 10.0→	10: 9.4 ↖	40 Skott		11: 10.1 ↗
		Serie 92.0		Serie 92.0										
		Total 92.0		Total 184.0										
40 Skott		21: 10.4x↘	22: 9.6 ↓	23: 9.8 →	24: 10.6x↑	25: 9.2 ←	26: 9.9 →	27: 8.4 ←	28: 9.5 ↖	29: 10.2x↗	30: 10.2x↘	40 Skott		31: 9.7 ↖
		Serie 93.0		Serie 90.0										
		Total 277.0		Total 367.0										

<p>Prov</p>	<p>1: 7.4 ←</p> <p>2: 8.7 ↓</p> <p>3: 8.5 →</p> <p>4: 9.4 ↓</p> <p>5: 9.5 ↓</p> <p>6: 8.6 ↑</p> <p>7: 9.6 →</p> <p>8: 7.1 ←</p> <p>9: 7.8 ↓</p> <p>10: 6.8 →</p> <p>Serie 78.0</p> <p>Total 0.0</p>	<p>Prov</p>	<p>11: 8.2 ↗</p> <p>12: 9.7 ↗</p> <p>13: 9.4 ↓</p> <p>14: 9.7 ↑</p> <p>15: 5.9 →</p> <p>16: 8.3 ↗</p> <p>17: 10.3x↓</p> <p>18: 6.8 ↘</p> <p>19: 10.1 →</p> <p>20: 9.9 ↓</p> <p>Serie 83.0</p> <p>Total 0.0</p>
<p>40 Skott</p>	<p>1: 9.5 →</p> <p>2: 9.7 ↑</p> <p>3: 9.3 ↑</p> <p>4: 8.4 ↘</p> <p>5: 8.0 ↘</p> <p>6: 9.6 ↑</p> <p>7: 10.4x→</p> <p>8: 8.1 →</p> <p>9: 6.7 →</p> <p>10: 10.6x←</p> <p>Serie 86.0</p> <p>Total 86.0</p>	<p>40 Skott</p>	<p>11: 8.8 ←</p> <p>12: 8.0 ↘</p> <p>13: 9.2 →</p> <p>14: 8.8 ↘</p> <p>15: 8.8 ↘</p> <p>16: 7.2 →</p> <p>17: 9.5 ↑</p> <p>18: 9.5 →</p> <p>19: 10.2x←</p> <p>20: 9.7 ↓</p> <p>Serie 85.0</p> <p>Total 171.0</p>
<p>40 Skott</p>	<p>21: 8.8 ↘</p> <p>22: 8.2 ↓</p> <p>23: 9.0 ↘</p> <p>24: 9.8 ↘</p> <p>25: 8.4 ↘</p> <p>26: 7.7 →</p> <p>27: 9.6 →</p> <p>28: 9.6 ↘</p> <p>29: 10.0 →</p> <p>30: 9.1 ↗</p> <p>Serie 86.0</p> <p>Total 257.0</p>	<p>40 Skott</p>	<p>31: 9.2 ↓</p> <p>32: 10.5x↘</p> <p>33: 9.3 ↗</p> <p>34: 6.9 ↑</p> <p>35: 7.7 →</p> <p>36: 7.3 →</p> <p>37: 9.0 ↓</p> <p>38: 8.6 ↘</p> <p>39: 9.6 ↘</p> <p>40: 8.1 →</p> <p>Serie 82.0</p> <p>Total 339.0</p>

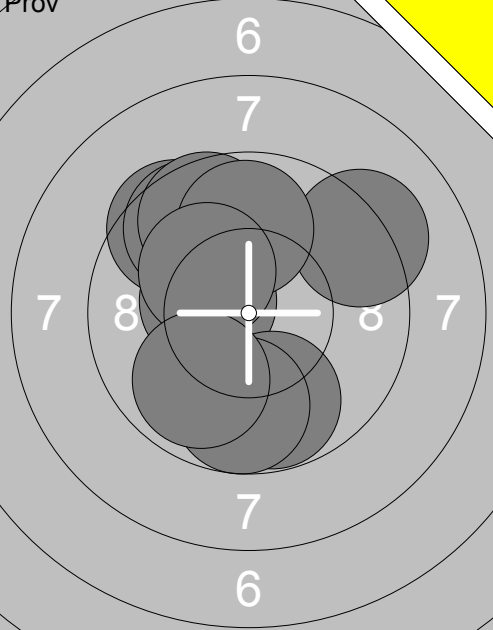
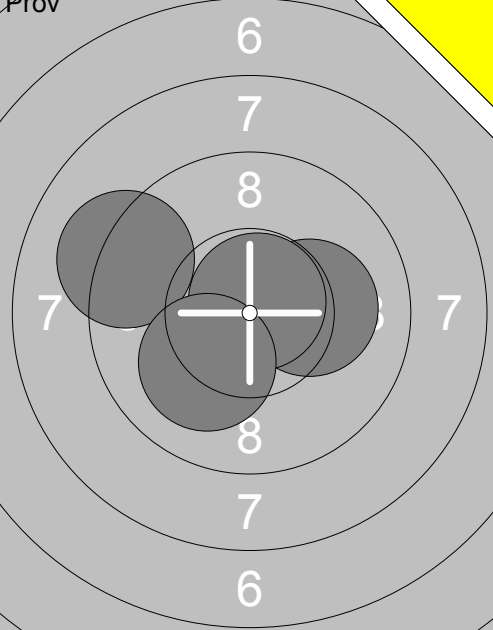
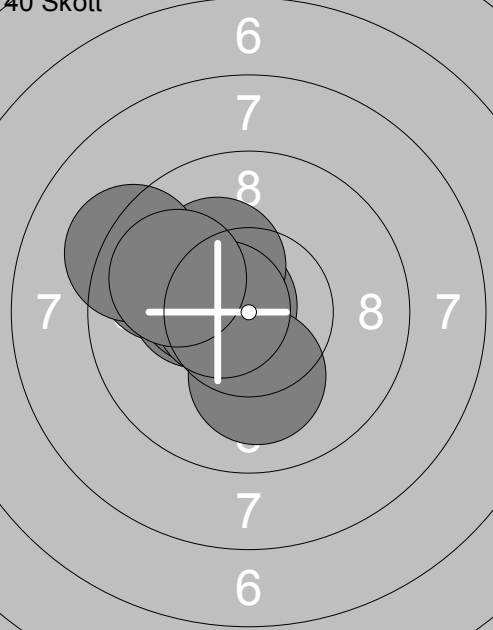
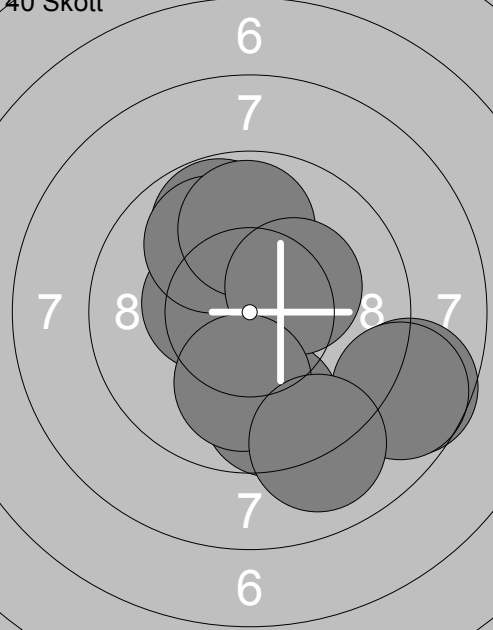
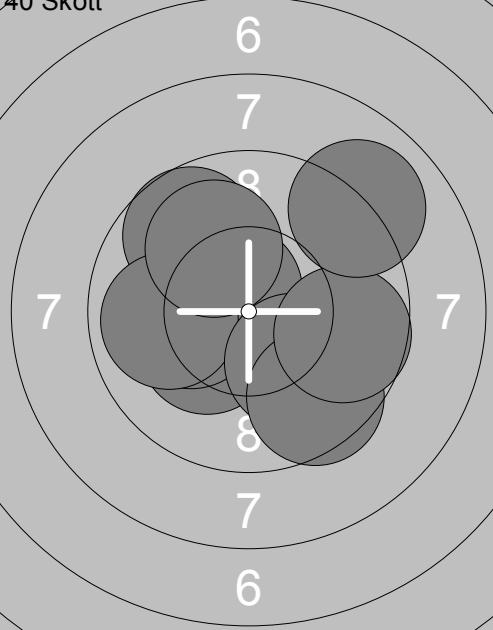
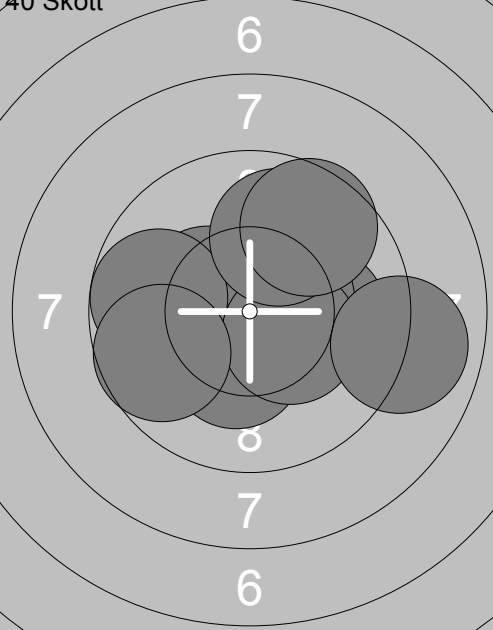
Prov	Förbundsmästerskap 2017	Ramselefors SKF
	1: 10.4x ↘ 2: 9.2 ↗ 3: 9.5 ↖ 4: 9.6 ↖ 5: 9.6 ↖ 6: 9.9 ↑ 7: 9.8 ↓ 8: 9.7 ↓ 9: 10.2x ↘ 10: 9.9 ↘ Serie 92.0 Total 0.0	
		11: 10.2x → 12: 10.8x ↗ 13: 9.2 ↖ 14: 10.1 ↘ Serie 39.0 Total 0.0
40 Skott 	1: 9.7 ↖ 2: 10.7x ↘ 3: 10.3x ↘ 4: 10.1 ↓ 5: 10.3x ↘ 6: 10.3x ↘ 7: 10.2x ↘ 8: 9.3 ↖ 9: 10.6x ↘ 10: 9.9 ↖ Serie 97.0 Total 97.0	40 Skott 
		11: 9.8 ↑ 12: 8.7 → 13: 10.4x ↘ 14: 9.9 ↖ 15: 8.7 → 16: 9.7 ↓ 17: 9.9 ↑ 18: 10.3x ↗ 19: 10.0 ↓ 20: 9.0 ↘ Serie 91.0 Total 188.0
40 Skott 	21: 10.2x ↘ 22: 10.2x ↘ 23: 10.6x ↘ 24: 9.7 ↖ 25: 9.9 ← 26: 10.1 ↓ 27: 9.5 ↓ 28: 9.7 → 29: 10.0 ↖ 30: 9.0 ↗ Serie 95.0 Total 283.0	40 Skott 
		31: 10.3x ↘ 32: 10.0 → 33: 10.4x ↘ 34: 10.5x ↗ 35: 9.8 ← 36: 10.3x ↘ 37: 9.7 ↖ 38: 9.0 → 39: 9.9 ↑ 40: 9.6 ↗ Serie 95.0 Total 378.0

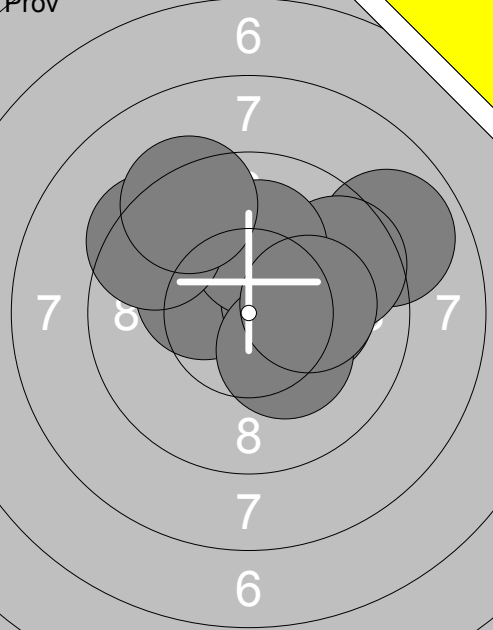
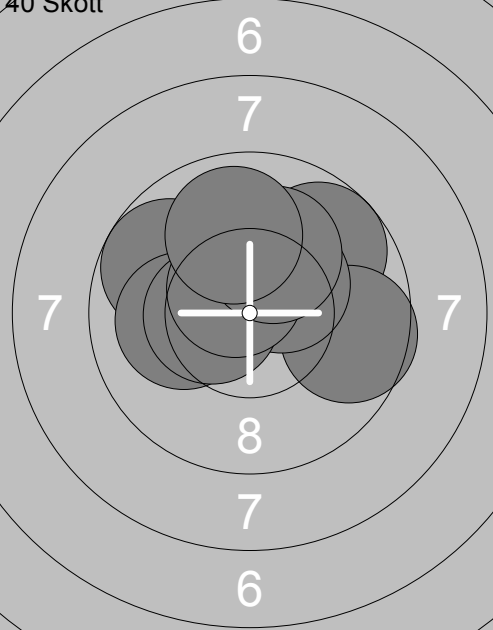
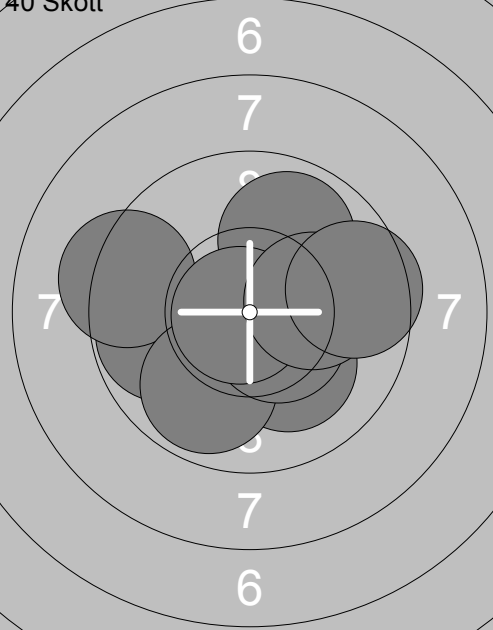
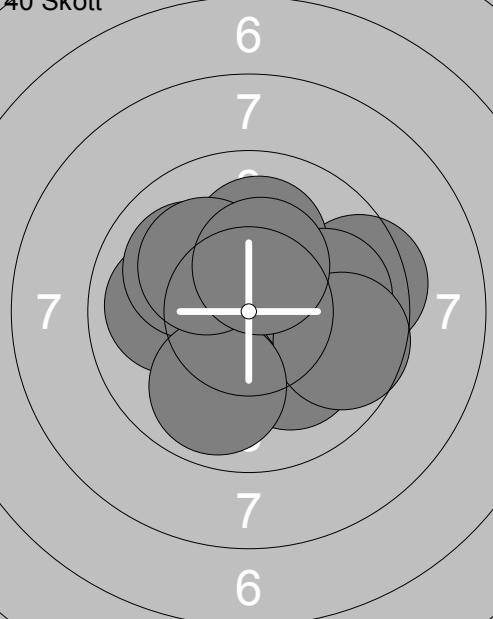
<p>Prov</p> 	<p>40 Skott</p> 	<p>40 Skott</p> 
<p>1: 10.3x ↘</p> <p>2: 10.4x →</p> <p>3: 10.2x →</p> <p>4: 8.9 ↗</p> <p>5: 9.6 ↗</p> <p>6: 10.1 ↑</p> <p>7: 10.3x ↘</p> <p>8: 9.4 ↖</p> <p>9: 9.3 ↖</p> <p>10: 10.2x →</p>	<p>11: 9.5 ↖</p> <p>12: 10.0 ↖</p> <p>13: 9.3 ↗</p> <p>14: 9.8 ↗</p> <p>15: 9.4 ↗</p> <p>16: 10.2x ↘</p> <p>17: 9.7 ↗</p> <p>18: 9.9 →</p> <p>19: 10.6x ↓</p> <p>20: 9.1 ↑</p>	<p>21: 10.0 ↗</p> <p>22: 9.8 ←</p> <p>23: 9.3 ←</p> <p>24: 10.1 ↘</p> <p>25: 9.9 ↓</p> <p>26: 9.9 ↑</p> <p>27: 10.5x ↘</p> <p>28: 10.8x ←</p> <p>29: 10.1 →</p> <p>30: 9.6 →</p>
Serie 95.0	Serie 93.0	Serie 95.0
Total 0.0	Total 189.0	Total 284.0
<p>40 Skott</p> 	<p>31: 10.0 ←</p> <p>32: 10.1 ↘</p> <p>33: 9.5 →</p> <p>34: 10.0 ↖</p> <p>35: 10.1 ↑</p> <p>36: 10.0 →</p> <p>37: 9.7 →</p> <p>38: 9.9 ↓</p> <p>39: 10.1 ↖</p> <p>40: 10.3x ↑</p>	
Serie 97.0		
Total 381.0		

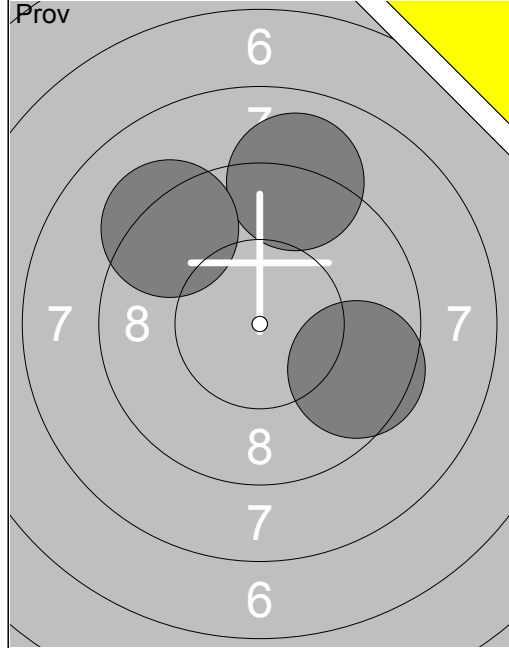

- 1: 9.0 ↑
- 2: 9.6 →
- 3: 9.2 ↖

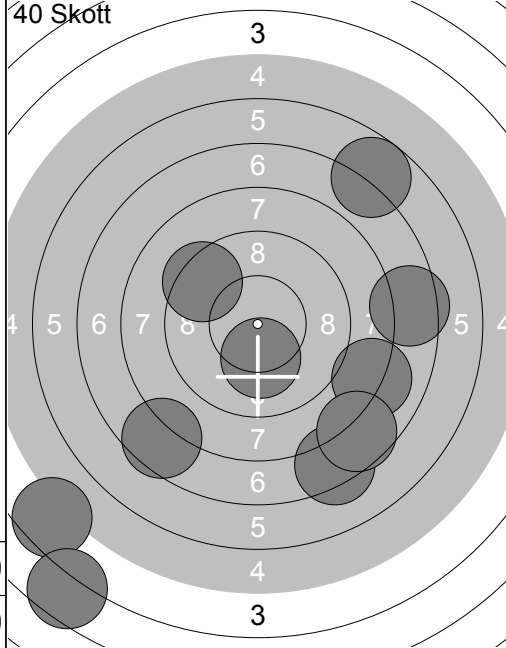

- 4: 6.7 ↗
- 5: 4.6 ↙
- 6: 8.1 →
- 7: 7.5 →
- 8: 3.6 ↙
- 9: 9.4 ↖
- 10: 10.2x ↓
- 11: 7.6 ↙
- 12: 7.3 ↓
- 13: 7.6 ↓

Serie 27.0
Total 0.0

Serie 68.0
Total 68.0

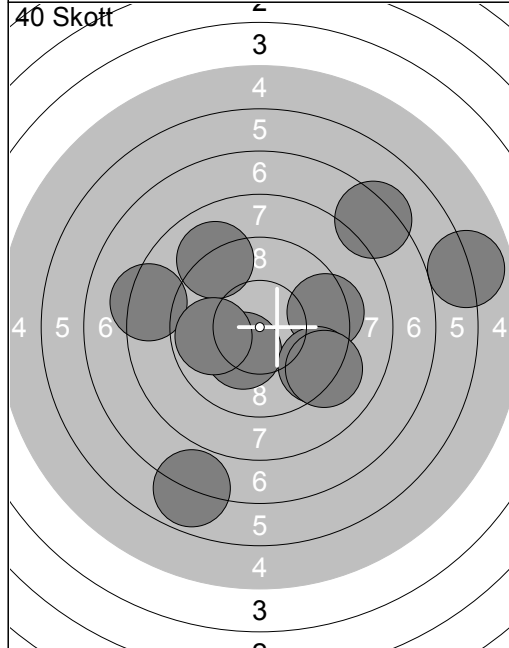

- 14: 9.1 ↖
- 15: 10.3x ↓
- 16: 8.3 ←
- 17: 9.9 ←
- 18: 9.4 →
- 19: 6.9 ↙
- 20: 9.4 ↘
- 21: 9.2 ↘
- 22: 7.3 ↗
- 23: 5.9 →

Serie 81.0
Total 149.0

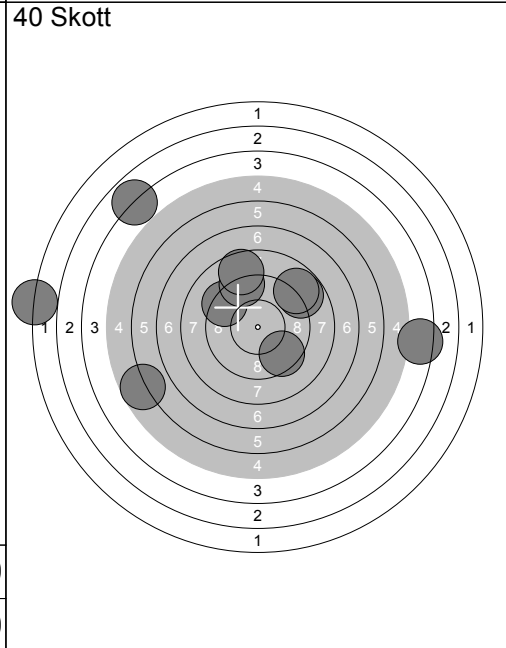

- 24: 5.7 ←
- 25: 9.5 ↓
- 26: 4.4 →
- 27: 8.8 ↗
- 28: 9.3 ↖
- 29: 1.9 ←
- 30: 8.8 ↗
- 31: 9.1 ↑
- 32: 8.6 ↑
- 33: 3.9 ↖

Serie 64.0
Total 213.0

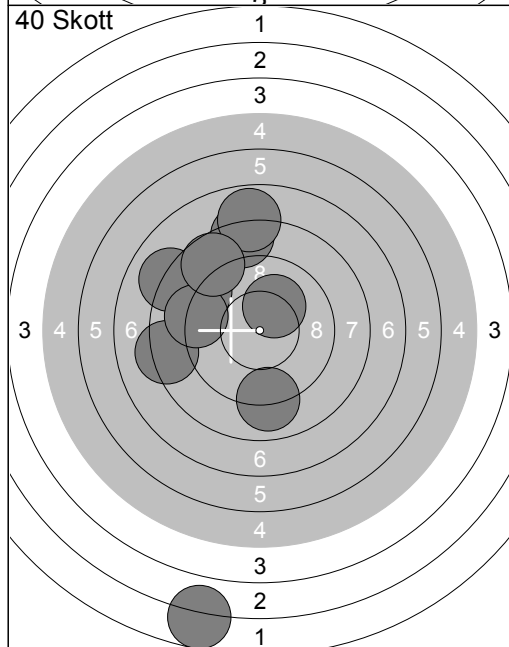

- 34: 8.9 ↖
- 35: 9.0 ↓
- 36: 8.2 ↑
- 37: 8.1 ↖
- 38: 7.8 ↑
- 39: 8.3 ←
- 40: 9.1 ←
- 41: 10.2x ↗
- 42: 8.7 ↖
- 43: 2.7 ↓

Serie 77.0
Total 290.0

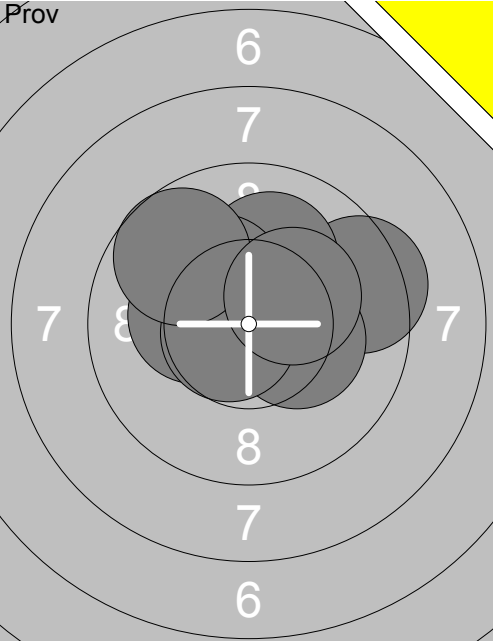
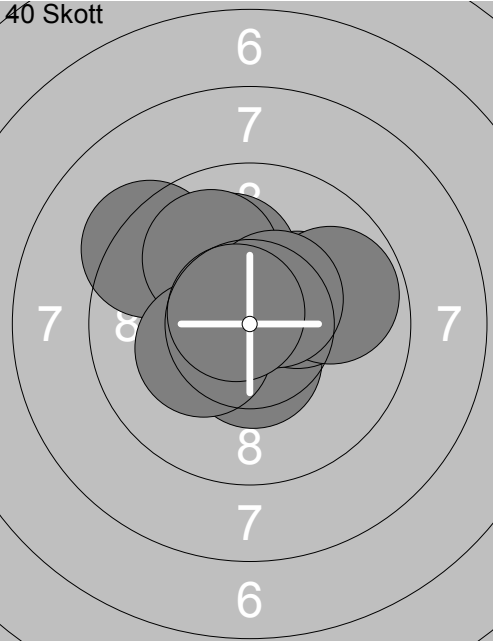
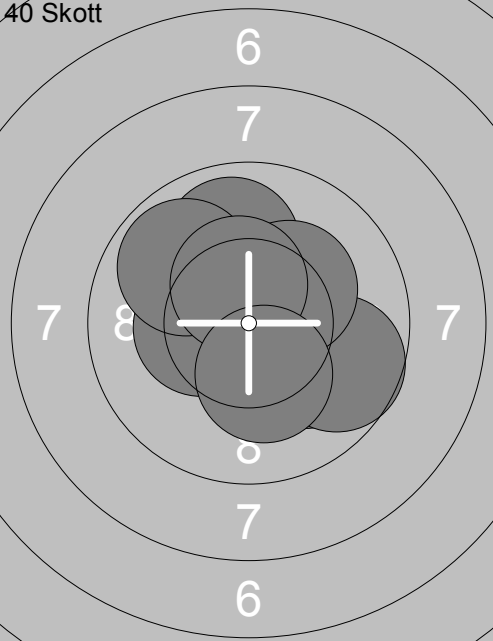
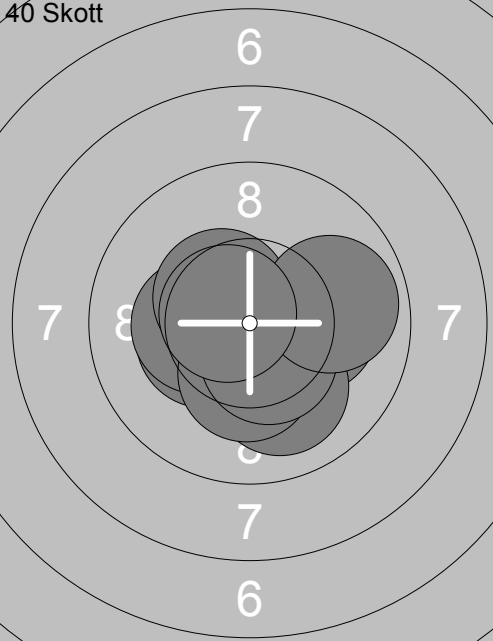
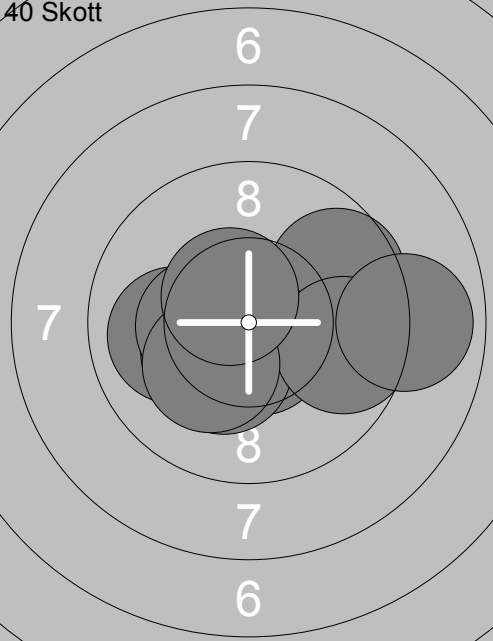
Skjuttag	Tavla	Hanna Lundin			
2	8	Vindeln	Umeå	Jun	Vb
28.01.2017		Förbundsmästerskap 2017		Ramselefors SKF	
Prov		1: 9.4 →	40 Skott		1: 10.4 ✕
		2: 10.1 ↑			2: 10.5x ↓
		3: 10.3x ↘			3: 10.3x ↗
		4: 10.3x →			4: 9.8 →
		5: 10.3x ✕			5: 10.1 ↑
		6: 10.7x ✕			6: 9.3 ↘
		7: 9.7 ↘			7: 10.0 ↘
		8: 10.3x ↗			8: 10.3x ✕
					9: 10.5x ↗
					10: 10.7x ✕
		Serie 78.0			Serie 98.0
		Total 0.0			Total 98.0
40 Skott		11: 9.9 ↑	40 Skott		21: 10.3x ✕
		12: 10.1 →			22: 10.3x ✕
		13: 10.5x →			23: 10.2x →
		14: 10.4x ↘			24: 10.6x ↓
		15: 9.7 →			25: 10.4x ↘
		16: 10.3x ✕			26: 10.0 ↓
		17: 9.8 ↘			27: 10.3x ↓
		18: 10.3x ↗			28: 10.5x ↓
		19: 10.4x ↑			29: 9.9 →
		20: 10.3x ↓			30: 10.6x ✕
		Serie 97.0			Serie 99.0
		Total 195.0			Total 294.0
40 Skott		31: 9.7 →			
		32: 10.6x ↓			
		33: 10.3x ↓			
		34: 10.0 ←			
		35: 10.3x ✕			
		36: 10.4x ✕			
		37: 9.7 →			
		38: 8.9 →			
		39: 10.2x ↓			
		40: 10.5x ↘			
		Serie 96.0			
		Total 390.0			

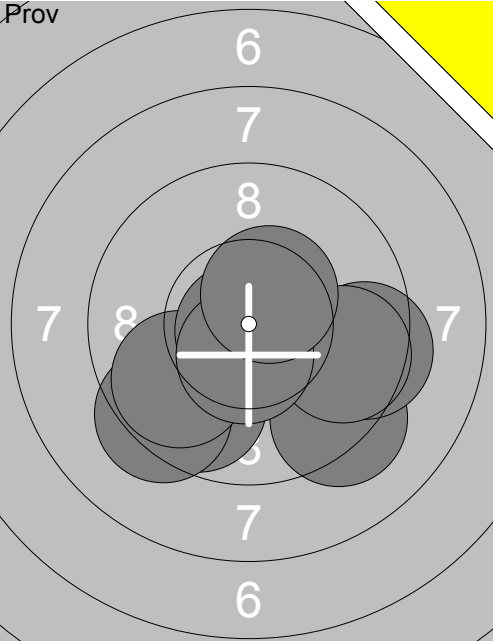
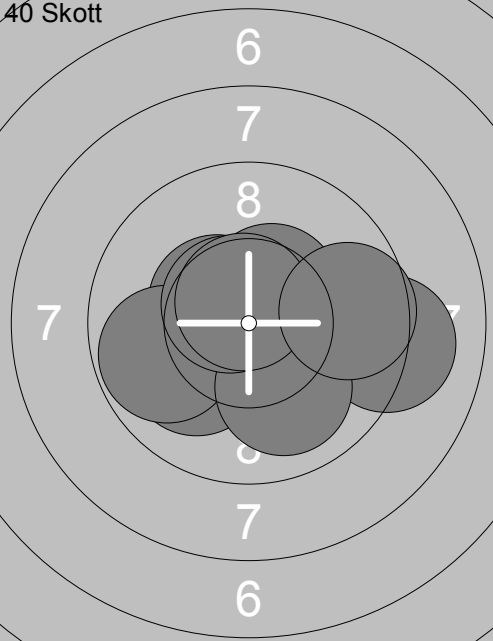
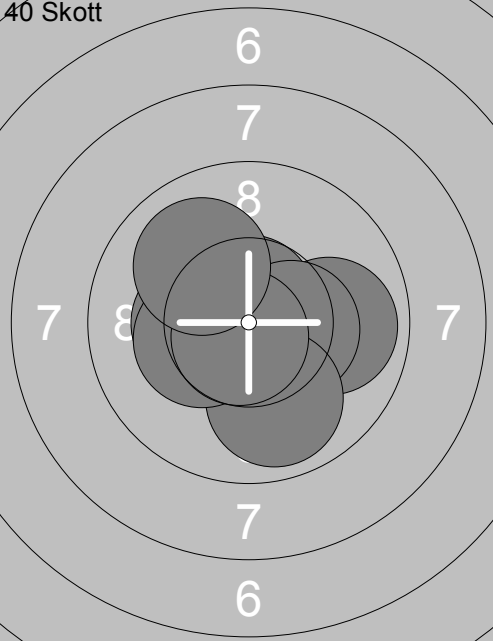
Skjuttag	Tavla	Saul Johansson	
2	9		
Vindeln	Ramselefors	Sen	Vb
28.01.2017	Förbundsmästerskap 2017	Ramselefors SKF	
Prov		1: 10.6x ↘ 2: 9.7 ↓ 3: 9.3 ↙ 4: 9.8 ↙ 5: 9.3 ↘ 6: 9.4 → 7: 10.8x ↘ 8: 9.7 → 9: 10.5x ↘ 10: 10.5x ↗ Serie 94.0 Total 0.0	11: 10.2x ↘ 12: 10.5x ↗ Serie 20.0 Total 0.0
40 Skott		1: 10.1 ↙ 2: 10.8x ↘ 3: 10.5x ↘ 4: 10.4x ↗ 5: 9.8 ← 6: 9.1 → 7: 10.0 ↓ 8: 10.6x ↘ 9: 10.7x ↗ 10: 9.6 → Serie 97.0 Total 97.0	11: 9.7 ← 12: 10.4x ↘ 13: 10.9x ↘ 14: 10.2x ↘ 15: 9.8 → 16: 10.2x ↘ 17: 10.8x ↗ 18: 10.7x ← 19: 10.8x ↘ 20: 10.6x → Serie 98.0 Total 195.0
40 Skott		21: 10.4x ↘ 22: 10.3x ← 23: 9.9 → 24: 10.7x ↘ 25: 10.7x ↗ 26: 10.4x → 27: 9.9 ↓ 28: 10.3x ← 29: 10.7x ↘ 30: 10.0 ↖ Serie 98.0 Total 293.0	31: 10.0 ↗ 32: 9.6 → 33: 10.6x ↗ 34: 9.8 → 35: 10.3x ↗ 36: 9.9 ↗ 37: 10.7x ↘ 38: 10.8x ↘ 39: 10.0 ← 40: 10.5x ↗ Serie 97.0 Total 390.0

Prov 	1: 9.3 ↘ 2: 9.6 ↓ 3: 7.4 ← 4: 8.7 ↘ 5: 9.9 ↘ 6: 9.3 → 7: 9.6 ↘ 8: 8.6 → 9: 10.5x↘ 10: 10.6x↘ <hr/> Serie 88.0 Total 0.0	Prov 	11: 9.6 → 12: 9.6 ↗ 13: 9.8 ↑ 14: 10.2x→ 15: 10.3x↓ <hr/> Serie 47.0 Total 0.0
----------	--	----------	--

40 Skott 	1: 10.6x↘ 2: 9.1 ← 3: 9.6 ↑ 4: 9.5 ← 5: 9.6 ← 6: 8.4 → 7: 9.3 → 8: 10.4x↘ 9: 9.4 ↘ 10: 9.8 ↗ <hr/> Serie 91.0 Total 91.0	40 Skott 	11: 10.0 ↓ 12: 9.4 ↗ 13: 9.1 → 14: 9.2 ← 15: 10.6x↑ 16: 10.0 → 17: 8.6 → 18: 9.8 ↗ 19: 9.5 ↓ 20: 9.2 ↘ <hr/> Serie 92.0 Total 183.0
--------------	---	--------------	--

40 Skott 	21: 9.4 → 22: 9.4 → 23: 10.2x↓ 24: 8.4 ↘ 25: 9.1 ↘ 26: 10.5x↘ 27: 9.1 ↘ 28: 10.8x↘ 29: 9.6 ← 30: 10.2x↓ <hr/> Serie 93.0 Total 276.0	40 Skott 	31: 10.5x↘ 32: 10.3x↘ 33: 9.5 ↓ 34: 9.3 ↗ 35: 9.7 ↓ 36: 10.3x→ 37: 8.7 ↓ 38: 10.1 ↓ 39: 10.2x↘ 40: 10.4x↘ <hr/> Serie 95.0 Total 371.0
--------------	---	--------------	---

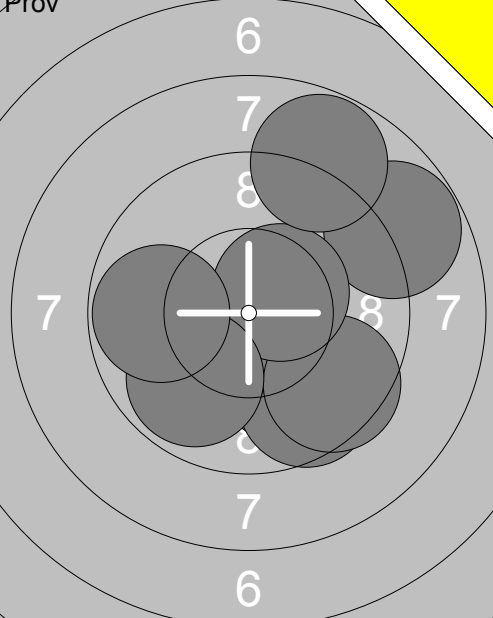
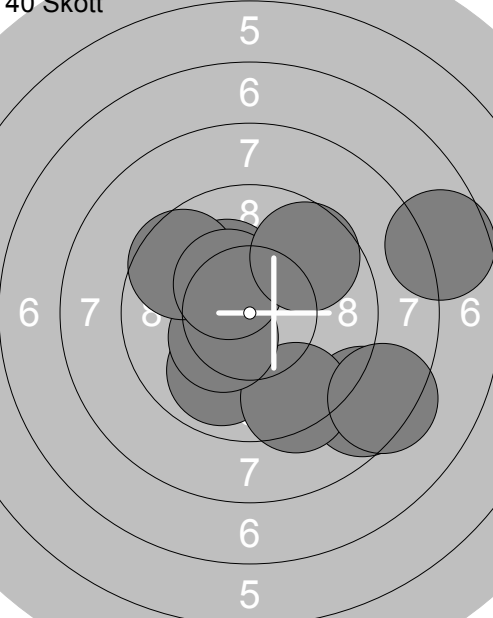
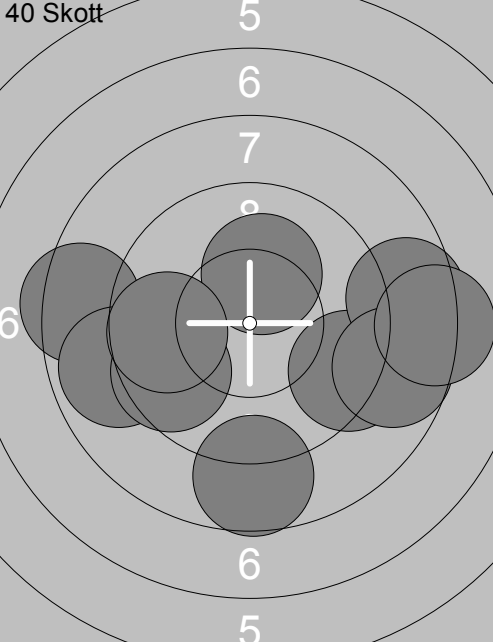
<p>Prov</p> 	<p>40 Skott</p> 	<p>40 Skott</p> 
<p>1: 8.8 ↗</p> <p>2: 10.6x↘</p> <p>3: 10.1 ↓</p> <p>4: 9.6 ↓</p> <p>5: 10.1 ↙</p> <p>6: 9.5 ↓</p> <p>7: 10.5x↗</p> <p>8: 8.8 ↑</p> <p>9: 9.8 ↓</p> <p>10: 9.8 ←</p>	<p>1: 8.6 ↘</p> <p>2: 9.9 ↓</p> <p>3: 9.4 ↓</p> <p>4: 10.2x↘</p> <p>5: 7.7 →</p> <p>6: 10.4x↙</p> <p>7: 9.6 ↖</p> <p>8: 8.4 ↘</p> <p>9: 10.4x↘</p> <p>10: 9.7 ↗</p>	<p>21: 8.4 ←</p> <p>22: 9.3 →</p> <p>23: 8.6 →</p> <p>24: 8.7 ↓</p> <p>25: 8.7 →</p> <p>26: 8.9 ←</p> <p>27: 9.6 ↖</p> <p>28: 10.2x↗</p> <p>29: 9.7 ←</p> <p>30: 8.2 →</p>
<p>Serie 92.0</p> <p>Total 0.0</p>	<p>Serie 89.0</p> <p>Total 89.0</p>	<p>Serie 85.0</p> <p>Total 264.0</p>

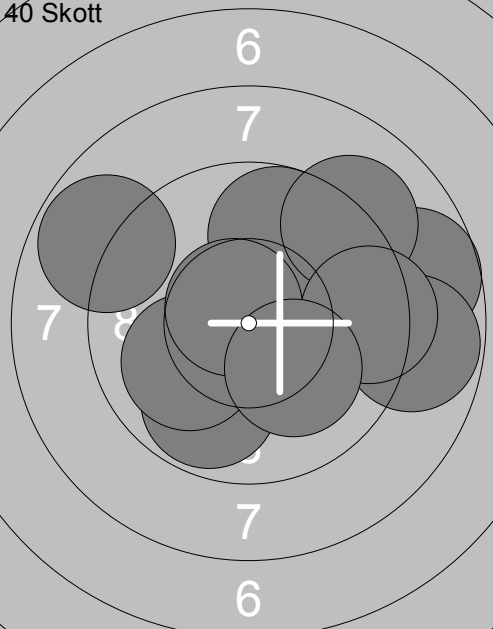
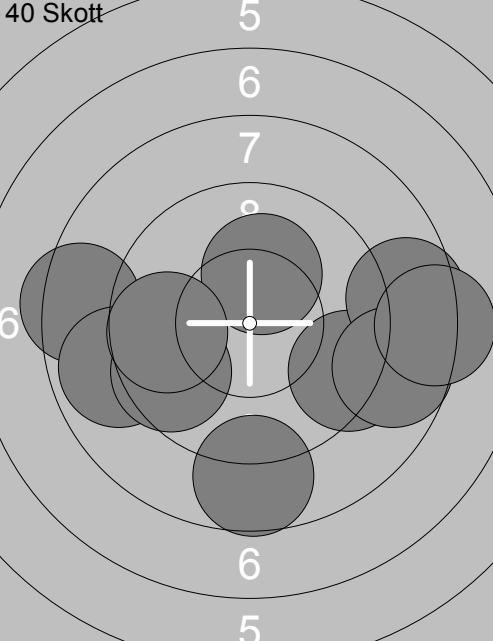
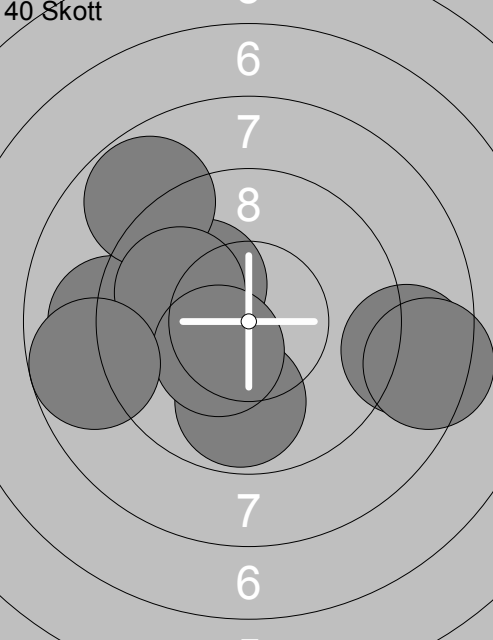
<p>40 Skott</p> 	<p>40 Skott</p> 	<p>40 Skott</p> 
<p>11: 9.7 ↑</p> <p>12: 8.8 ↖</p> <p>13: 9.8 ↓</p> <p>14: 10.0 ↖</p> <p>15: 8.7 →</p> <p>16: 9.1 ↗</p> <p>17: 8.8 →</p> <p>18: 9.4 →</p> <p>19: 10.7x↘</p> <p>20: 10.1 ↓</p>	<p>31: 10.1 ↖</p> <p>32: 8.7 →</p> <p>33: 9.9 ↖</p> <p>34: 8.4 →</p> <p>35: 9.1 ←</p> <p>36: 8.8 ↗</p> <p>37: 9.8 ↓</p> <p>38: 9.9 ↖</p> <p>39: 10.4x↙</p> <p>40: 8.8 ←</p>	<p>Serie 88.0</p> <p>Total 352.0</p>

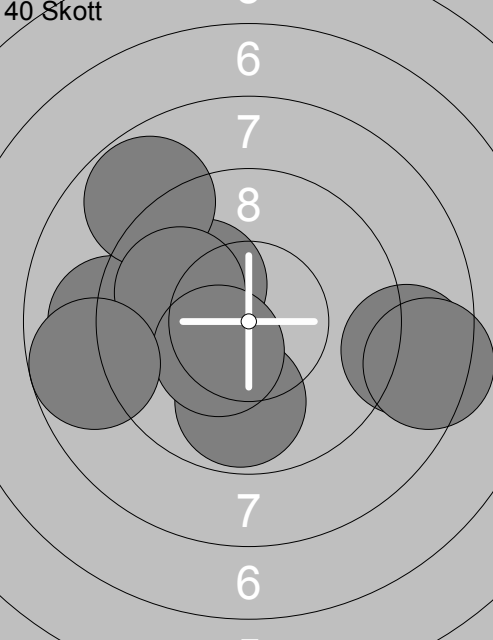
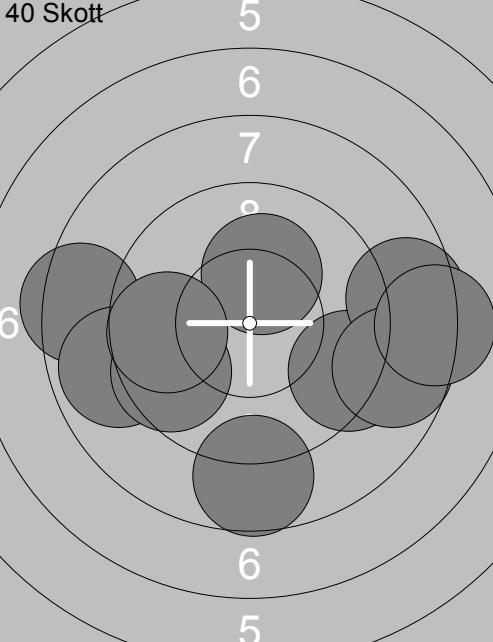
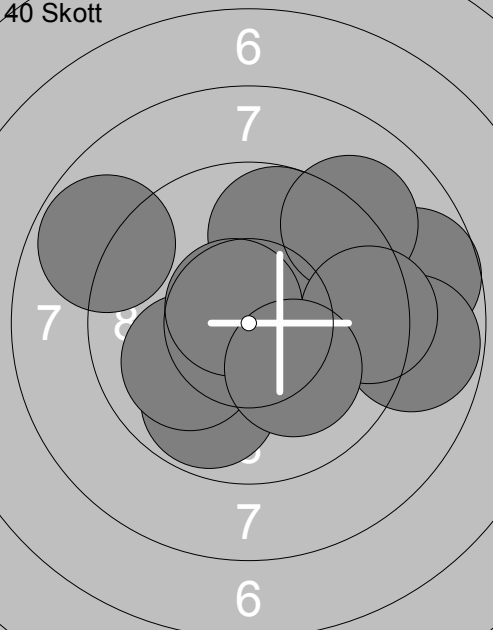
<p>40 Skott</p> 	<p>40 Skott</p> 	<p>40 Skott</p> 
<p>Serie 90.0</p> <p>Total 179.0</p>	<p>Serie 85.0</p> <p>Total 264.0</p>	<p>Serie 88.0</p> <p>Total 352.0</p>

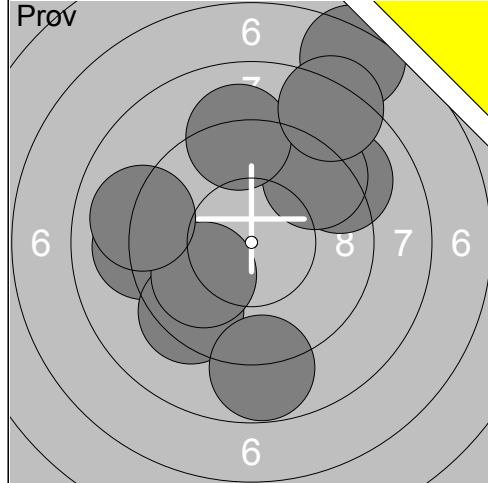

1:	9.1	←
2:	9.4	↙
3:	10.0	↙
4:	9.0	←
5:	9.1	↗
6:	9.4	↗
7:	9.1	↑
8:	8.8	↓
9:	7.3	↗
10:	8.3	↗

Serie	87.0
Total	0.0

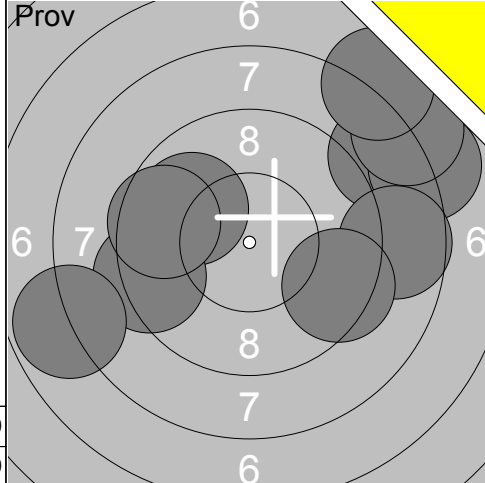

11:	8.4	↗
12:	7.9	↗
13:	7.9	↗
14:	9.9	↖
15:	9.3	↖
16:	7.8	↖
17:	8.6	→
18:	9.4	↘
19:	7.7	↗
20:	9.6	↖

Serie	80.0
Total	0.0

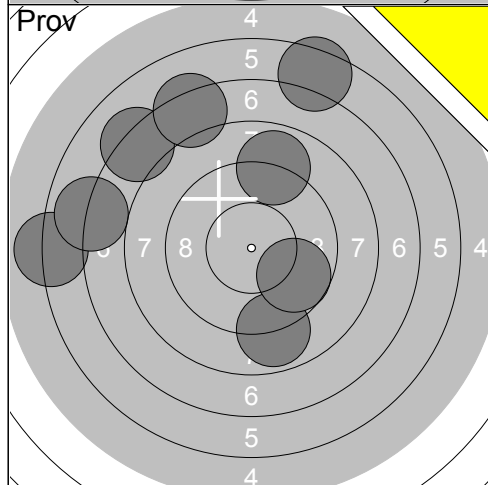

21:	6.1	←
22:	7.2	↗
23:	6.4	↑
24:	8.9	↓
25:	8.9	↑
26:	7.0	←
27:	7.3	↗
28:	9.7	↘

Serie	58.0
Total	0.0

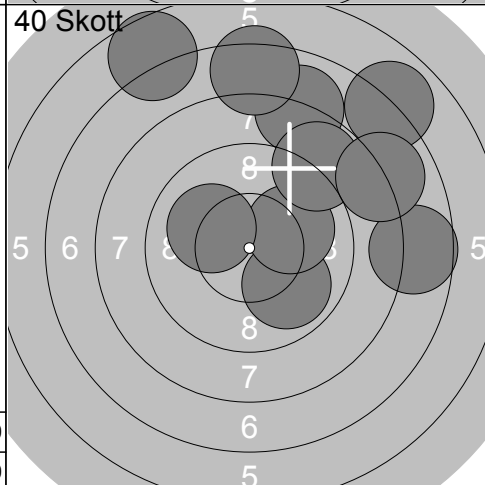

1:	8.0	↑
2:	9.9	↘
3:	7.7	→
4:	10.1	↗
5:	10.1	↖
6:	6.9	↗
7:	8.8	↗
8:	8.0	↗
9:	6.6	↑
10:	7.4	↑

Serie	79.0
Total	79.0

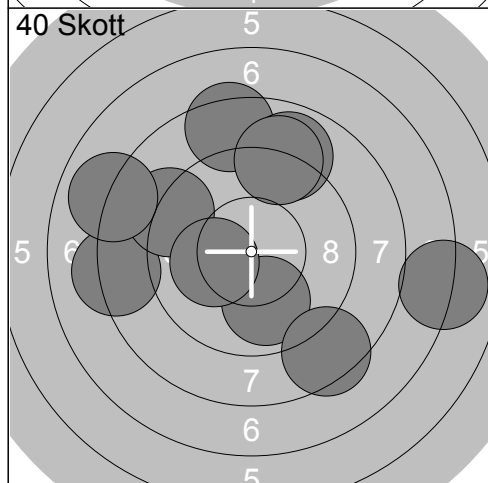

11:	8.4	↑
12:	7.0	→
13:	8.9	↑
14:	8.2	←
15:	9.9	↘
16:	8.4	↘
17:	9.1	↗
18:	9.0	↑
19:	8.0	↖
20:	10.2x	←

Serie	84.0
Total	163.0

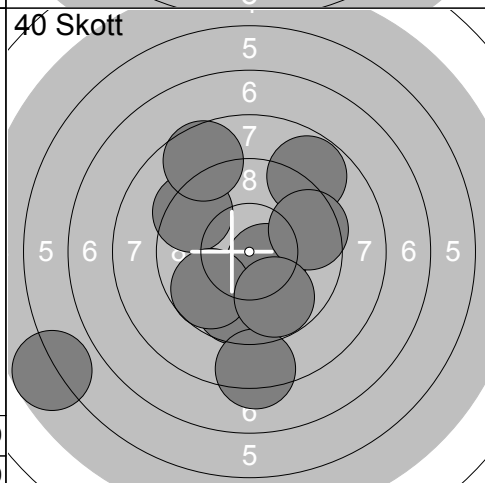

21:	5.7	↖
22:	8.8	↗
23:	9.7	↓
24:	10.5x	↘
25:	9.4	↖
26:	9.5	→
27:	8.6	↑
28:	8.3	↓
29:	9.7	↖
30:	9.8	↘

Serie	84.0
Total	247.0

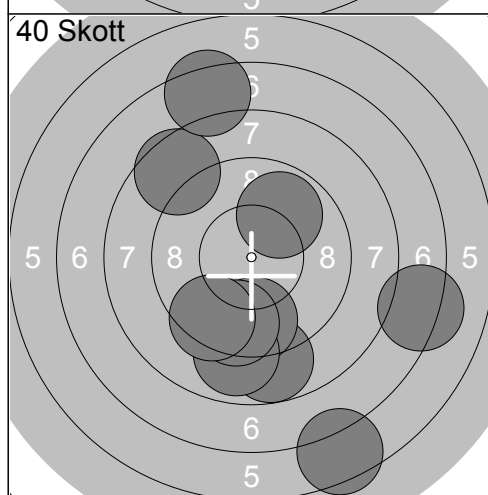

31:	8.6	↗
32:	6.5	↘
33:	7.4	↗
34:	8.8	↘
35:	9.6	↘
36:	7.2	→
37:	9.9	↗
38:	8.9	↓
39:	9.5	↓
40:	9.4	↘

Serie	80.0
Total	327.0

 <p style="font-size: small;">Pröv</p>	<p>1: 9.1 ↙</p> <p>2: 8.3 ↘</p> <p>3: 9.2 →</p> <p>4: 8.5 ↘</p> <p>5: 8.7 ↓</p> <p>6: 10.1 ↗</p> <p>7: 10.1 ↗</p> <p>8: 7.4 ←</p> <p>9: 8.7 ↑</p> <p>10: 10.8x➤</p>	<p>40 Skott</p>  <p>1: 10.3x↑</p> <p>2: 8.0 ←</p> <p>3: 9.8 ↗</p> <p>4: 10.5x↑</p> <p>5: 10.3x↑</p> <p>6: 9.4 →</p> <p>7: 9.3 →</p> <p>8: 8.5 ←</p> <p>9: 10.3x➤</p> <p>10: 9.9 ←</p>
Serie 87.0		Serie 92.0
Total 0.0		Total 92.0

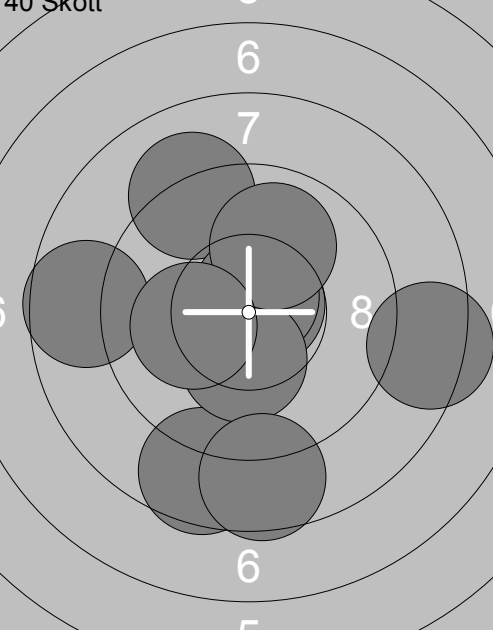
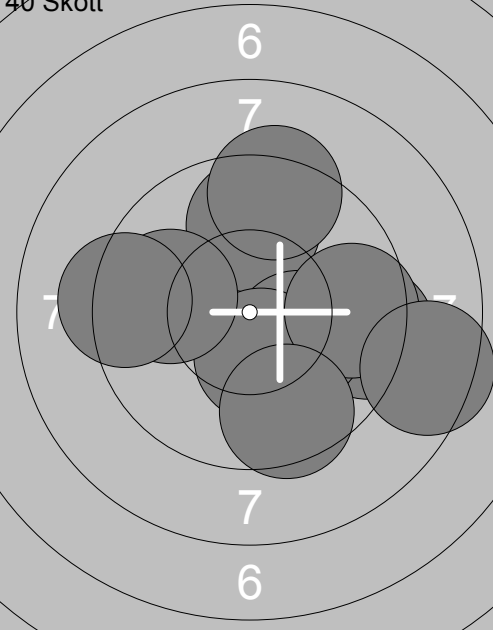
<p>40 Skott</p> 	<p>11: 8.6 ↓</p> <p>12: 9.1 ↗</p> <p>13: 8.7 ←</p> <p>14: 10.7x↗</p> <p>15: 8.3 →</p> <p>16: 10.7x↑</p> <p>17: 10.3x↓</p> <p>18: 8.6 ↓</p> <p>19: 10.0 ↑</p> <p>20: 10.1 ←</p>	<p>40 Skott</p>  <p>21: 9.4 →</p> <p>22: 9.8 ↑</p> <p>23: 10.2x➤</p> <p>24: 9.3 ↑</p> <p>25: 10.4x↓</p> <p>26: 9.9 ←</p> <p>27: 9.3 ←</p> <p>28: 9.6 →</p> <p>29: 9.5 ↓</p> <p>30: 8.5 ➤</p>
Serie 91.0		Serie 91.0
Total 183.0		Total 274.0

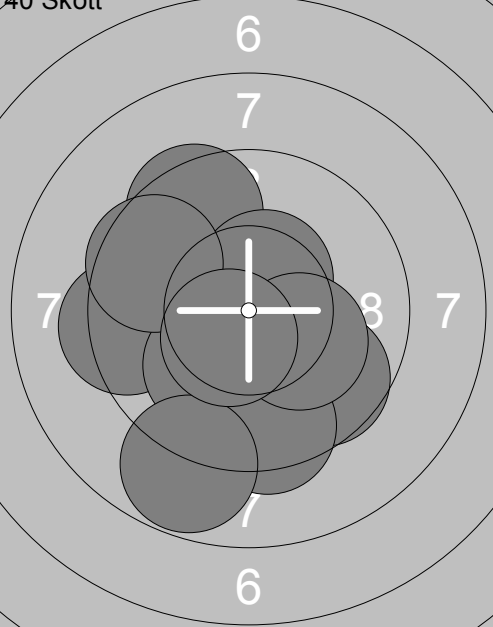
<p>40 Skott</p> 	<p>31: 9.7 ↘</p> <p>32: 9.5 ↗</p> <p>33: 9.4 ←</p> <p>34: 10.1 ↓</p> <p>35: 10.5x↑</p> <p>36: 9.6 ↖</p> <p>37: 9.4 ↓</p> <p>38: 10.2x➤</p> <p>39: 8.8 ↓</p> <p>40: 10.5x↓</p>	
Serie 93.0		
Total 367.0		

<p>Prov</p>	<p>1: 9.9 →</p> <p>2: 10.5x↘</p> <p>3: 10.5x↙</p> <p>4: 10.4x↗</p> <p>5: 10.0←</p> <p>6: 10.2x↖</p> <p>7: 10.4x↗</p> <p>8: 10.9x↘</p> <p>9: 10.9x↖</p> <p>10: 10.2x↙</p> <p>Serie 99.0</p> <p>Total 0.0</p>	<p>Prov</p>	<p>11: 10.8x↘</p> <p>12: 10.6x↙</p> <p>Serie 20.0</p> <p>Total 0.0</p>
<p>40 Skott</p>	<p>1: 10.7x↘</p> <p>2: 10.6x↘</p> <p>3: 10.7x↗</p> <p>4: 10.6x↘</p> <p>5: 10.7x↙</p> <p>6: 10.5x↘</p> <p>7: 10.6x↙</p> <p>8: 10.3x↘</p> <p>9: 10.6x↗</p> <p>10: 10.3x↙</p> <p>Serie 100.0</p> <p>Total 100.0</p>	<p>40 Skott</p>	<p>11: 10.7x↘</p> <p>12: 10.2x↙</p> <p>13: 10.8x↗</p> <p>14: 10.5x↘</p> <p>15: 10.2x↙</p> <p>16: 10.1 ↗</p> <p>17: 10.6x↙</p> <p>18: 10.4x↘</p> <p>19: 10.8x↙</p> <p>20: 10.4x↘</p> <p>Serie 100.0</p> <p>Total 200.0</p>
<p>40 Skott</p>	<p>21: 10.1 ↓</p> <p>22: 10.3x↘</p> <p>23: 10.7x↘</p> <p>24: 10.4x↗</p> <p>25: 10.5x↗</p> <p>26: 10.3x↗</p> <p>27: 10.6x↙</p> <p>28: 10.5x↗</p> <p>29: 10.6x↙</p> <p>30: 10.7x↙</p> <p>Serie 100.0</p> <p>Total 300.0</p>	<p>40 Skott</p>	<p>31: 10.6x↗</p> <p>32: 10.6x→</p> <p>33: 10.7x↗</p> <p>34: 10.6x→</p> <p>35: 10.5x↙</p> <p>36: 10.5x↗</p> <p>37: 10.5x↗</p> <p>38: 10.4x↖</p> <p>39: 10.6x→</p> <p>40: 10.9x↙</p> <p>Serie 100.0</p> <p>Total 400.0</p>

<p>Prov</p>	<p>1: 10.7x↗ 2: 10.4x➤ 3: 9.8 ➤ 4: 10.2x↗ 5: 10.4x➤ 6: 10.1 ➤ 7: 10.1 ➤ 8: 10.8x↘ 9: 10.7x↘ 10: 10.3x↘</p> <p>Serie 99.0 Total 0.0</p>	<p>Prov</p>	<p>11: 10.8x➤</p> <p>Serie 10.0 Total 0.0</p>
<p>40 Skott</p>	<p>1: 10.6x➤ 2: 10.5x➤ 3: 10.5x↘ 4: 10.5x↘ 5: 10.4x↔ 6: 10.6x↗ 7: 10.7x↗ 8: 10.6x↔ 9: 10.7x↔ 10: 10.7x➤</p> <p>Serie 100.0 Total 100.0</p>	<p>40 Skott</p>	<p>11: 10.6x↔ 12: 10.3x↗ 13: 10.3x↔ 14: 10.5x➤ 15: 10.8x↘ 16: 10.9x↗ 17: 10.4x↗ 18: 10.2x↗ 19: 10.7x↘ 20: 10.8x↗</p> <p>Serie 100.0 Total 200.0</p>
<p>40 Skott</p>	<p>21: 10.5x↘ 22: 10.2x↘ 23: 10.8x↔ 24: 10.6x➤ 25: 10.6x↘ 26: 10.2x➤ 27: 10.4x↔ 28: 10.8x↗ 29: 10.3x↘ 30: 10.6x➤</p> <p>Serie 100.0 Total 300.0</p>	<p>40 Skott</p>	<p>31: 10.6x↘ 32: 10.5x↔ 33: 10.9x↘ 34: 10.9x↘ 35: 10.7x➤ 36: 10.0 ↗ 37: 10.7x↘ 38: 10.2x➤ 39: 10.2x↘ 40: 10.6x↗</p> <p>Serie 100.0 Total 400.0</p>

	<p>1: 9.6 →</p> <p>2: 10.2x↗</p> <p>3: 10.1 ↗</p> <p>4: 10.7x←</p> <p>5: 10.3x↘</p> <p>6: 10.5x↓</p> <p>7: 10.5x↘</p> <p>8: 10.7x↗</p> <p>9: 9.9 ↗</p> <p>10: 10.3x→</p>		<p>11: 10.6x↘</p> <p>12: 10.2x←</p> <p>13: 10.6x↗</p> <p>14: 10.7x→</p> <p>15: 10.8x↗</p>
Serie 98.0		Serie 50.0	
Total 0.0		Total 0.0	

	<p>1: 10.5x←</p> <p>2: 10.5x↓</p> <p>3: 10.6x↘</p> <p>4: 10.5x→</p> <p>5: 10.7x↗</p> <p>6: 10.6x←</p> <p>7: 10.6x↗</p> <p>8: 10.8x↗</p> <p>9: 10.2x↘</p> <p>10: 10.7x→</p>		<p>11: 10.6x↗</p> <p>12: 10.8x↗</p> <p>13: 10.5x↓</p> <p>14: 10.4x↗</p> <p>15: 10.7x↓</p> <p>16: 10.4x↗</p> <p>17: 10.8x↗</p> <p>18: 9.7 →</p> <p>19: 10.6x↗</p> <p>20: 10.7x↘</p>
Serie 100.0		Serie 99.0	
Total 100.0		Total 199.0	

	<p>21: 10.7x↘</p> <p>22: 10.5x↗</p> <p>23: 9.8 →</p> <p>24: 10.7x←</p> <p>25: 10.1 ↙</p> <p>26: 10.7x↘</p> <p>27: 10.3x↗</p> <p>28: 10.6x↓</p> <p>29: 10.3x↘</p> <p>30: 10.5x←</p>		<p>31: 10.5x←</p> <p>32: 10.6x←</p> <p>33: 10.6x↗</p> <p>34: 10.6x↓</p> <p>35: 10.6x↘</p> <p>36: 10.5x←</p> <p>37: 10.5x↘</p> <p>38: 10.6x→</p> <p>39: 10.3x↓</p> <p>40: 10.8x↗</p>
Serie 99.0		Serie 100.0	
Total 298.0		Total 398.0	

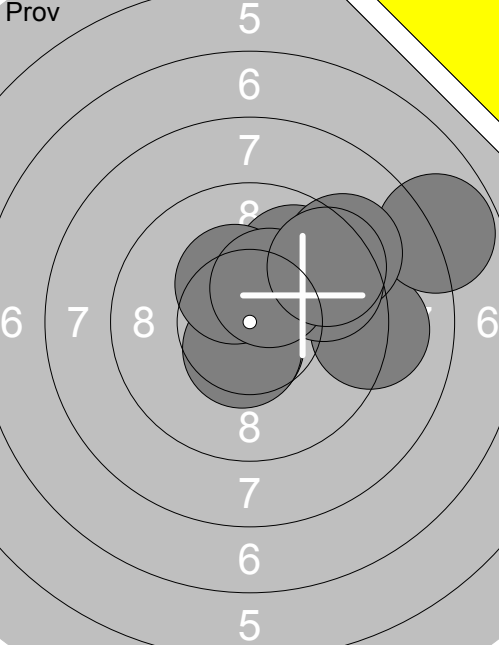
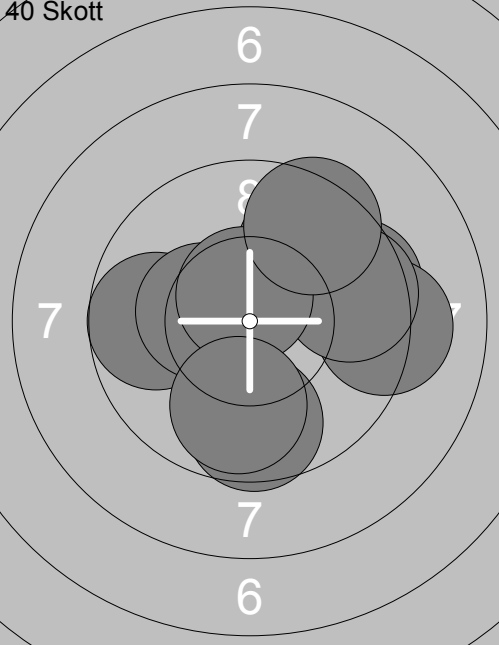
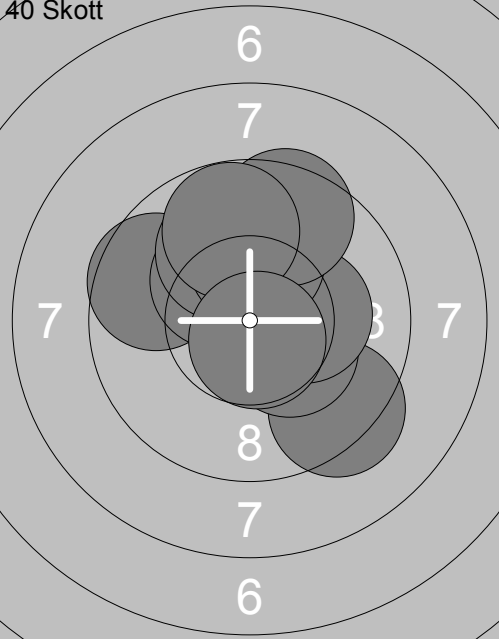
Skjuttag	Tavla	Daniel Johansson	
2	17		
Vindeln	Umeå	Sitt	Vb
28.01.2017	Förbundsmästerskap 2017	Ramselefors SKF	
Prov		1: 10.6x↓ 2: 10.5x↓ 3: 9.9 ↗ 4: 9.1 → 5: 7.8 ↗ 6: 10.3x↖ 7: 9.2 ↗ 8: 9.7 ↗ 9: 10.4x↗ 10: 9.5 ↗ Serie 92.0 Total 0.0	11: 10.8x↖ Serie 10.0 Total 0.0
40 Skott		1: 9.5 → 2: 9.7 ← 3: 10.3x↖ 4: 9.6 ↓ 5: 9.8 ↗ 6: 9.2 → 7: 9.6 → 8: 10.6x↗ 9: 9.8 ↓ 10: 9.5 ↗ Serie 92.0 Total 92.0	11: 9.4 ↗ 12: 9.0 ← 13: 8.2 ↗ 14: 9.8 ⇒ 15: 10.6x⇒ 16: 9.1 → 17: 9.4 → 18: 9.6 ↗ 19: 9.5 → 20: 8.8 ↗ Serie 89.0 Total 181.0
40 Skott		21: 9.6 ← 22: 9.3 ↘ 23: 10.3x↘ 24: 10.3x↖ 25: 10.0 ↗ 26: 10.2x⇒ 27: 10.1 ↗ 28: 9.5 ↗ 29: 9.8 ↗ 30: 10.7x↓ Serie 96.0 Total 277.0	31: 8.9 → 32: 9.5 ↗ 33: 8.0 ↗ 34: 10.1 ↗ 35: 9.4 → 36: 7.7 ← 37: 9.9 ↗ 38: 8.8 ↗ 39: 8.5 ← 40: 9.0 ↗ Serie 85.0 Total 362.0

<p>Prov</p> 	<p>1: 10.4x ↗</p> <p>2: 9.6 →</p> <p>3: 9.7 →</p> <p>4: 9.7 →</p> <p>5: 10.7x ↘</p> <p>6: 10.7x ↘</p> <p>7: 9.8 ↘</p> <p>8: 10.5x ↗</p> <p>9: 9.8 ↘</p> <p>10: 10.0 ↗</p> <p>Serie 95.0</p> <p>Total 0.0</p>	<p>Prov</p> 	<p>11: 9.7 ←</p> <p>12: 10.7x ↗</p> <p>Serie 19.0</p> <p>Total 0.0</p>
--	--	--	--

<p>40 Skott</p> 	<p>1: 10.7x ↘</p> <p>2: 10.1 ↘</p> <p>3: 10.0 ↗</p> <p>4: 10.7x ↘</p> <p>5: 9.8 ↘</p> <p>6: 9.6 →</p> <p>7: 10.1 ↗</p> <p>8: 10.2x ↗</p> <p>9: 10.3x ↘</p> <p>10: 9.6 →</p> <p>Serie 97.0</p> <p>Total 97.0</p>	<p>40 Skott</p> 	<p>11: 9.9 ↗</p> <p>12: 10.3x ↘</p> <p>13: 10.8x ↘</p> <p>14: 10.6x ↘</p> <p>15: 10.9x ↘</p> <p>16: 10.5x ↘</p> <p>17: 10.6x ↘</p> <p>18: 9.7 ↗</p> <p>19: 10.1 ↗</p> <p>20: 10.9x →</p> <p>Serie 98.0</p> <p>Total 195.0</p>
---	---	---	---

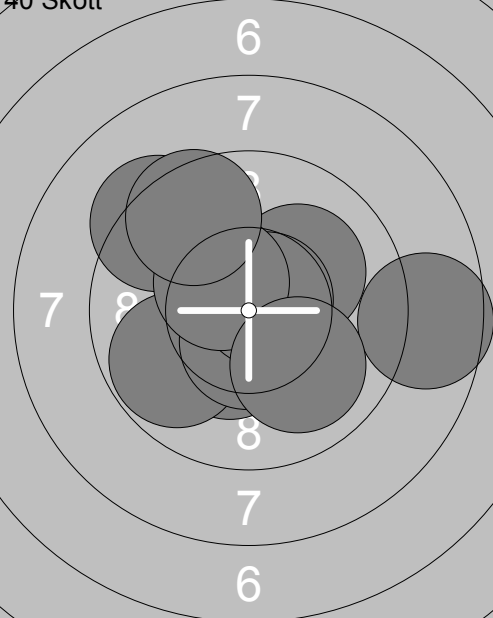
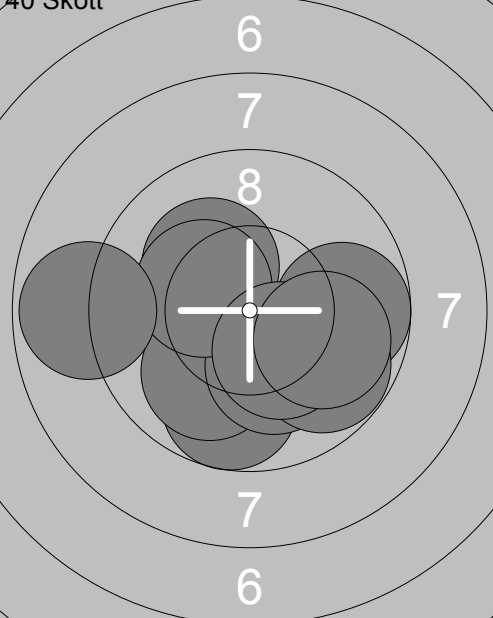
<p>40 Skott</p> 	<p>21: 9.3 ↗</p> <p>22: 10.4x ↘</p> <p>23: 8.6 →</p> <p>24: 10.1 ↗</p> <p>25: 9.8 ↗</p> <p>26: 10.5x ↘</p> <p>27: 10.7x ↗</p> <p>28: 10.4x ↗</p> <p>29: 10.0 ↘</p> <p>30: 9.5 ↗</p> <p>Serie 95.0</p> <p>Total 290.0</p>	<p>40 Skott</p> 	<p>31: 9.7 →</p> <p>32: 9.7 ↘</p> <p>33: 10.0 ↘</p> <p>34: 10.2x ↗</p> <p>35: 10.2x ↘</p> <p>36: 9.8 ↘</p> <p>37: 10.3x ↗</p> <p>38: 10.3x ↘</p> <p>39: 9.9 →</p> <p>40: 8.8 ←</p> <p>Serie 94.0</p> <p>Total 384.0</p>
--	--	--	---

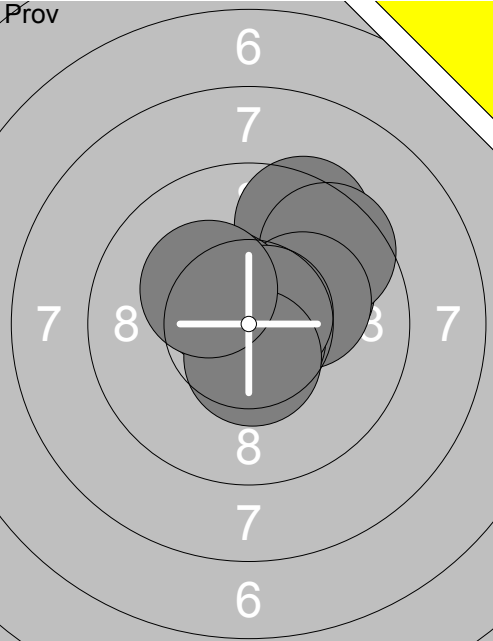
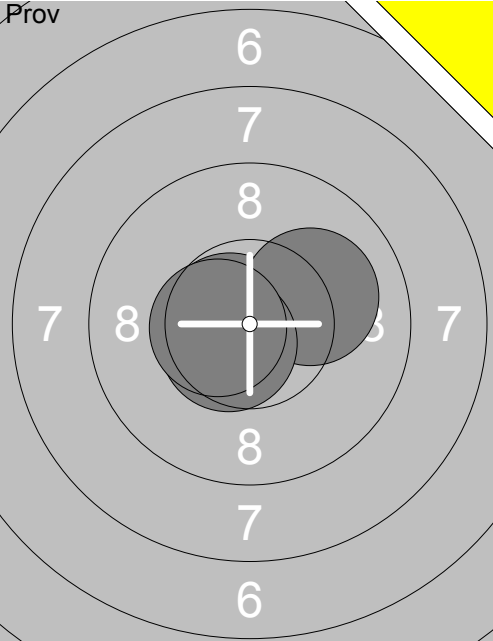
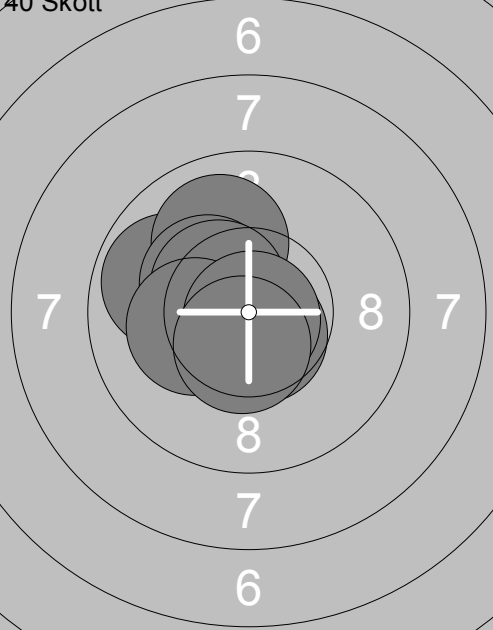
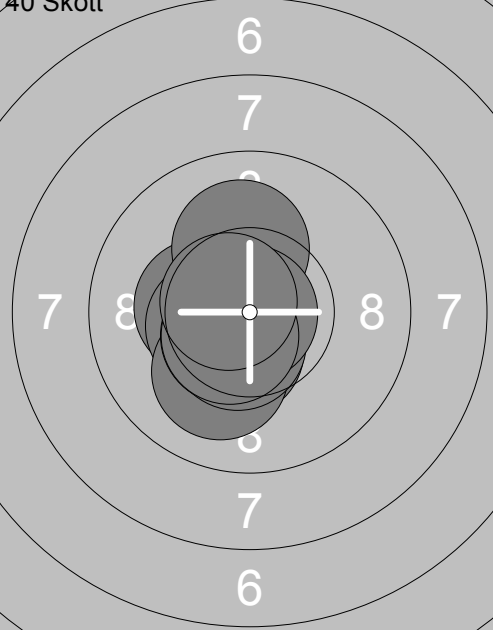
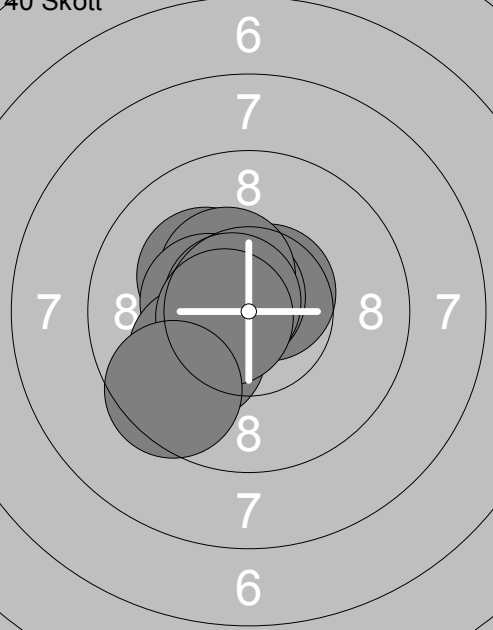
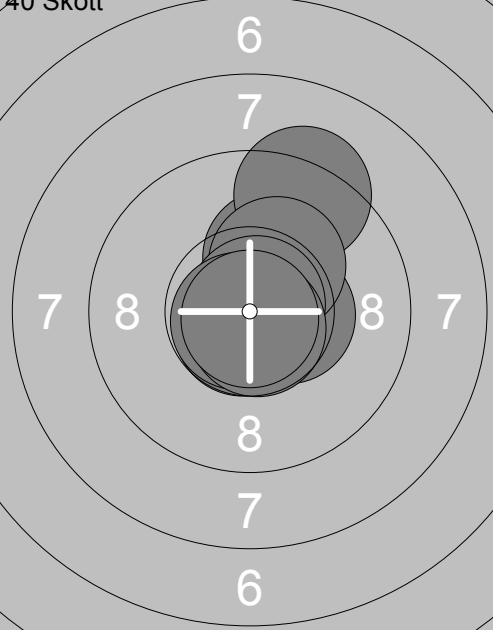
Skjutlag	Tavla	Fluk Jonsson		Sitt	Vb
2	19				
Vindeln	Ramselefors				
28.01.2017	Föbunds mästerskap 2017	Ramselefors SKF			
Prov		1: 10.1 ↗ 2: 9.5 ↗ 3: 10.8x ↗ 4: 9.6 ↗ 5: 10.2x ↗ 6: 10.7x ↘ 7: 10.5x ↘ 8: 10.7x ↗ 9: 10.5x ↘ 10: 10.3x ↘	Prov		11: 10.7x ↘ 12: 10.1 ↗ 13: 10.6x ↘ 14: 10.5x ↘
	Serie 98.0			Serie 40.0	
	Total 0.0			Total 0.0	
40 Skott		1: 9.9 ↙ 2: 10.5x ↘ 3: 10.0 ↗ 4: 10.7x ↘ 5: 10.3x ↘ 6: 10.6x ↘ 7: 10.5x ↘ 8: 10.2x ↘ 9: 10.8x ↘ 10: 10.5x ↘	40 Skott		11: 10.3x ↘ 12: 10.4x ↘ 13: 10.5x ↘ 14: 10.1 ↘ 15: 10.1 ↗ 16: 10.5x ↘ 17: 10.5x ↘ 18: 10.9x ↘ 19: 10.6x ↘ 20: 10.6x ↘
	Serie 99.0			Serie 100.0	
	Total 99.0			Total 199.0	
40 Skott		21: 10.6x ↗ 22: 10.2x ↘ 23: 10.6x ↘ 24: 10.7x ↘ 25: 10.4x ↘ 26: 10.4x ↘ 27: 10.1 ↘ 28: 10.7x ↘ 29: 10.6x ↘ 30: 9.5 ↘	40 Skott		31: 10.2x ↗ 32: 9.3 ↗ 33: 10.7x ↘ 34: 10.5x → 35: 10.9x ↘ 36: 10.3x ↗ 37: 10.8x ↗ 38: 10.8x ↘ 39: 10.7x ↘ 40: 10.9x ↘
	Serie 99.0			Serie 99.0	
	Total 298.0			Total 397.0	

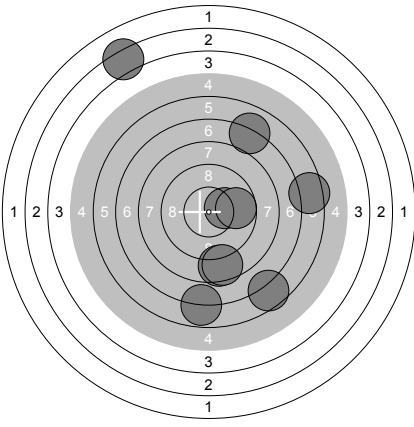
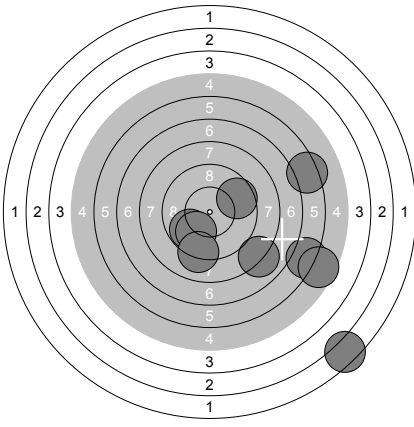

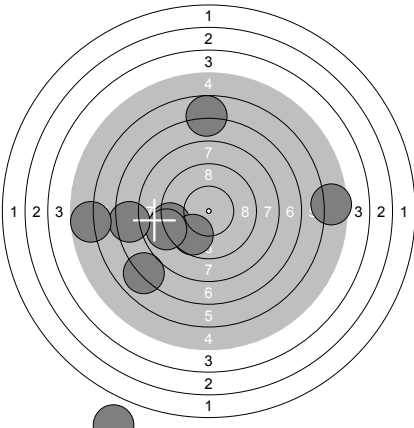
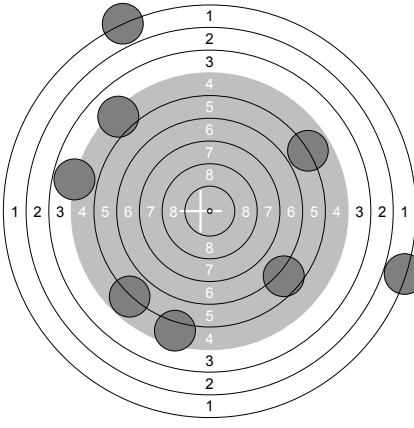
Prov 	40 Skott 1: 0.0 ← 2: 3.2 ↗ 3: 6.6 ↘ 4: 6.4 → 5: 8.6 ↓ 6: 10.2x → 7: 7.1 ↗ 8: 9.7 → 9: 6.8 ↓ 10: 8.5 ↓ <hr/> Serie 63.0 Total 0.0	 1: 8.0 ↘ 2: 0.0 → 3: 6.2 ↘ 4: 5.6 ↘ 5: 6.3 → 6: 2.4 ↘ 7: 9.8 ↙ 8: 9.9 ↙ 9: 9.1 ↓ 10: 9.6 → <hr/> Serie 63.0 Total 63.0
---	--	--

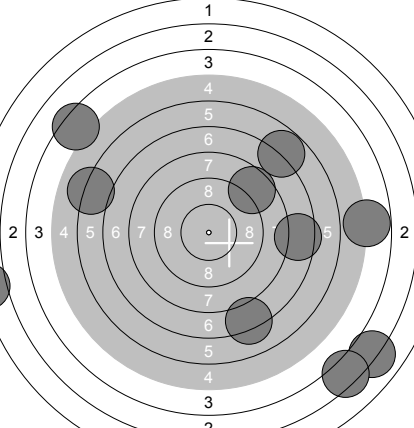
40 Skott 	40 Skott 11: 9.2 ← 12: 5.6 → 13: 9.7 ↘ 14: 8.9 ← 15: 0.0 ↓ 16: 7.0 ↙ 17: 7.4 ← 18: 6.7 ↗ 19: 0.0 ← 20: 5.7 ← <hr/> Serie 56.0 Total 119.0	 21: 5.8 ↙ 22: 4.8 ← 23: 5.9 → 24: 5.5 ↓ 25: 5.2 ↗ 26: 1.9 ↗ 27: 0.0 → 28: 1.9 → 29: 0.0 ← 30: 6.6 ↘ <hr/> Serie 32.0 Total 151.0
--	---	---

40 Skott 	31: 4.8 → 32: 2.1 ← 33: 3.0 ↘ 34: 6.1 ← 35: 8.6 ↗ 36: 7.5 → 37: 3.3 ↘ 38: 7.2 ↓ 39: 4.3 ↗ 40: 6.8 ↗ <hr/> Serie 50.0 Total 201.0	
---	---	--

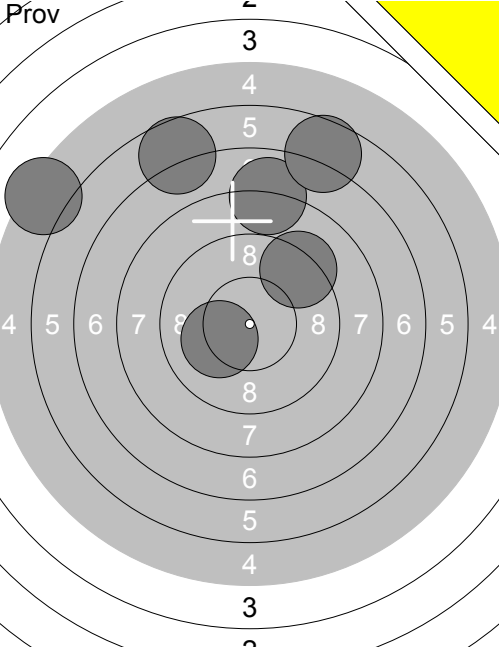
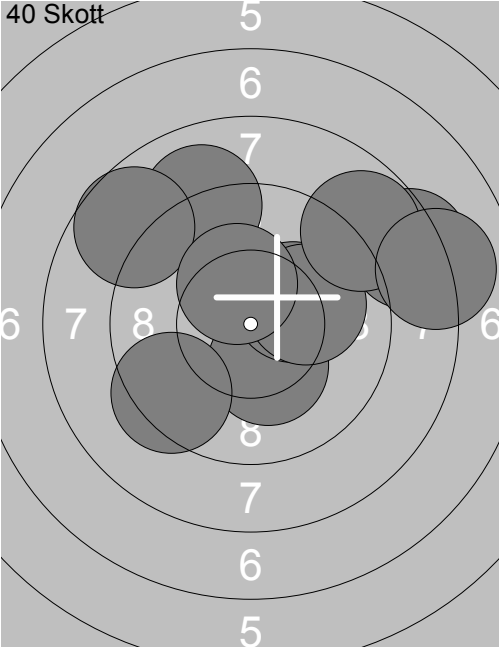
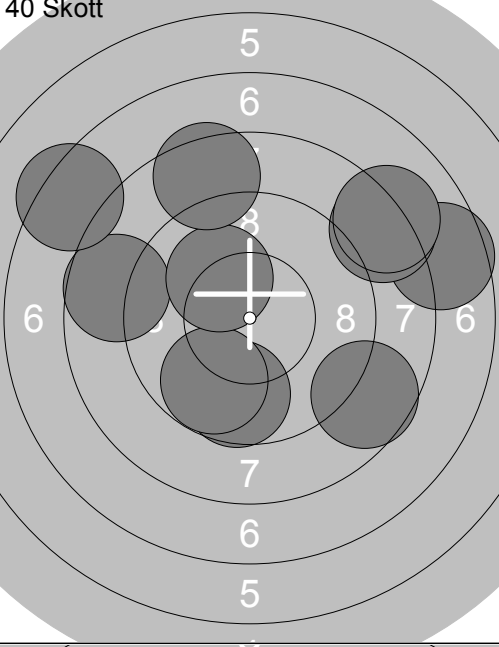
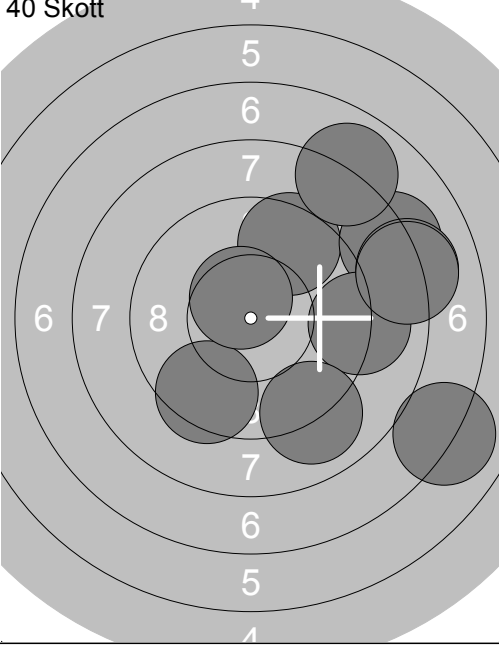
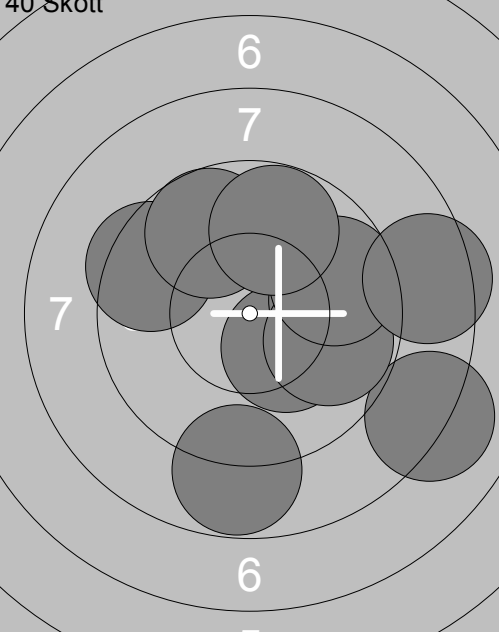
<p>Prov</p>	<p>1: 8.1 ←</p> <p>2: 9.5 ↓</p> <p>3: 10.1 ←</p> <p>4: 10.1 →</p> <p>5: 10.1 ↑</p> <p>6: 10.5x ↙</p> <p>7: 10.8x ↗</p> <p>8: 9.8 →</p> <p>9: 8.3 ↗</p> <p>10: 9.6 ↑</p> <p>Serie 93.0</p> <p>Total 0.0</p>	<p>Prov</p>	<p>11: 10.6x ↘</p> <p>12: 10.3x ↗</p> <p>13: 9.5 ↗</p> <p>14: 10.4x ↗</p> <p>15: 10.3x ↙</p> <p>16: 10.2x ↗</p> <p>17: 9.9 ↓</p> <p>18: 10.6x ↗</p> <p>19: 10.1 ↙</p> <p>Serie 88.0</p> <p>Total 0.0</p>
<p>40 Skott</p>	<p>1: 10.3x →</p> <p>2: 10.0 ←</p> <p>3: 10.1 ↓</p> <p>4: 10.4x ↗</p> <p>5: 10.5x ↘</p> <p>6: 10.4x ↗</p> <p>7: 10.7x →</p> <p>8: 10.2x ↘</p> <p>9: 10.2x ↘</p> <p>10: 10.3x ↘</p> <p>Serie 100.0</p> <p>Total 100.0</p>	<p>40 Skott</p>	<p>11: 10.7x ↘</p> <p>12: 9.3 ↓</p> <p>13: 10.2x ↘</p> <p>14: 10.0 ↗</p> <p>15: 10.2x ↘</p> <p>16: 9.8 ↗</p> <p>17: 9.9 ←</p> <p>18: 10.5x ↓</p> <p>19: 9.3 ↓</p> <p>20: 10.2x ↘</p> <p>Serie 96.0</p> <p>Total 196.0</p>
<p>40 Skott</p>	<p>21: 10.2x ↘</p> <p>22: 10.6x ↘</p> <p>23: 10.2x ↙</p> <p>24: 9.8 ↗</p> <p>25: 10.1 ←</p> <p>26: 10.0 →</p> <p>27: 10.3x →</p> <p>28: 10.6x ↗</p> <p>29: 9.3 ↗</p> <p>30: 9.8 ↗</p> <p>Serie 97.0</p> <p>Total 293.0</p>	<p>40 Skott</p>	<p>31: 8.5 ↓</p> <p>32: 10.2x ↙</p> <p>33: 10.6x →</p> <p>34: 10.2x ↘</p> <p>35: 10.4x ↗</p> <p>36: 9.9 ↗</p> <p>37: 10.5x ↘</p> <p>38: 10.6x ↗</p> <p>39: 10.8x ↙</p> <p>40: 9.9 ←</p> <p>Serie 96.0</p> <p>Total 389.0</p>

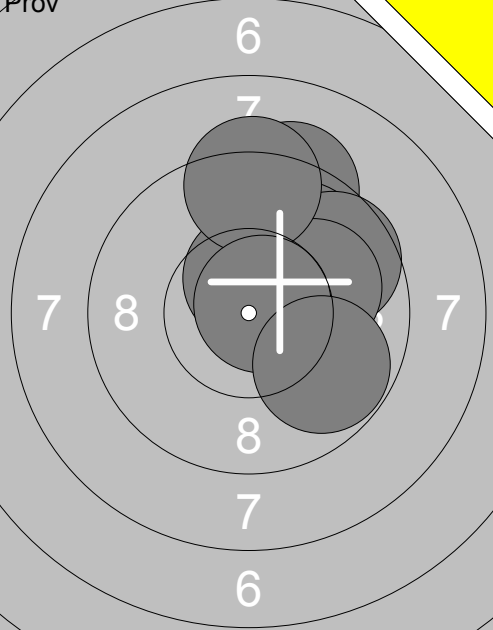
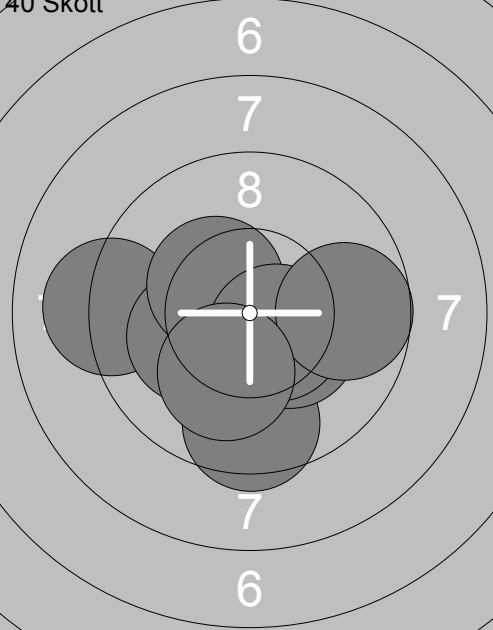
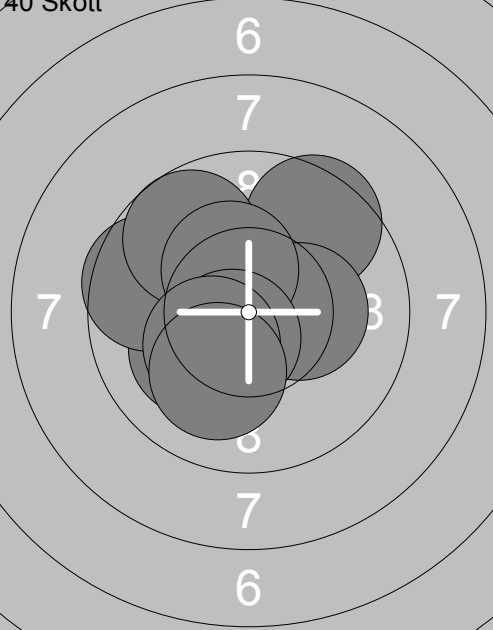
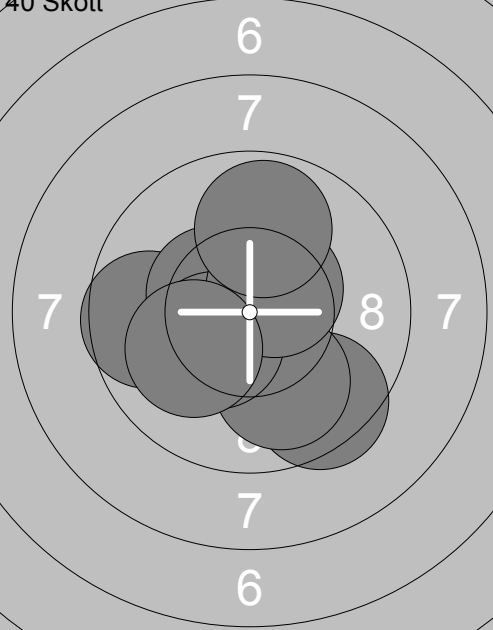
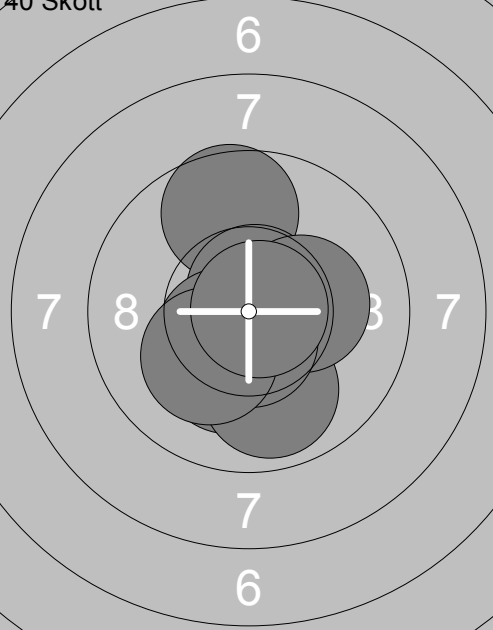
Skjutlag	Tavla	Jan-Olov Jonson			
2	24	Vindeln	Umeå	Funk	Vb
28.01.2017		Förbundsmästerskap 2017		Ramselefors SKF	
	1: 10.2x ↘		1: 10.3x ↘		
	2: 9.3 ↗		2: 9.4 ↙		
	3: 5.3 ↖		3: 10.2x ↗		
	4: 7.9 ↑		4: 8.3 ↗		
	5: 6.7 ↖		5: 10.1 →		
	6: 6.6 ↗		6: 9.0 ↑		
			7: 8.7 ↖		
			8: 8.8 ↗		
			9: 10.3x ↘		
			10: 8.1 →		
	Serie 43.0		Serie 90.0		
	Total 0.0		Total 90.0		
	11: 7.6 →		21: 9.5 ↑		
	12: 9.7 ↓		22: 8.2 ↗		
	13: 8.6 ↘		23: 9.1 →		
	14: 9.8 ↓		24: 8.1 →		
	15: 8.7 ↖		25: 9.0 ↓		
	16: 8.3 ↗		26: 9.5 ↓		
	17: 10.1 ↖		27: 7.0 ↘		
	18: 8.1 ↗		28: 7.9 ↑		
	19: 8.5 ↑		29: 10.6x ↘		
	20: 7.3 ↖		30: 8.1 →		
	Serie 82.0		Serie 84.0		
	Total 172.0		Total 256.0		
	31: 8.1 ↘				
	32: 8.8 ↓				
	33: 10.3x ↘				
	34: 9.8 →				
	35: 9.8 ↘				
	36: 9.4 ↖				
	37: 9.7 ↖				
	38: 9.7 ↗				
	39: 9.8 ↑				
	40: 8.5 →				
	Serie 88.0				
	Total 344.0				

<p>Prov</p> 	<p>40 Skott</p> 	<p>1: 10.7x ↗</p> <p>2: 9.4 ↑</p> <p>3: 9.3 ↑</p> <p>4: 10.5x ↑</p> <p>5: 9.9 ↗</p> <p>6: 9.7 ↗</p> <p>7: 10.0 →</p> <p>8: 9.3 ↑</p> <p>9: 10.7x ↗</p> <p>10: 9.8 ↘</p> <hr/> <p>Serie 94.0</p> <p>Total 0.0</p>
<p>40 Skott</p> 	<p>40 Skott</p> 	<p>11: 10.4x ↘</p> <p>12: 9.5 ↗</p> <p>13: 10.1 ↙</p> <p>14: 9.6 ←</p> <p>15: 9.7 ↖</p> <p>16: 10.3x →</p> <p>17: 10.3x ↗</p> <p>18: 10.5x ↘</p> <p>19: 10.3x ↘</p> <p>20: 10.1 ↘</p> <hr/> <p>Serie 97.0</p> <p>Total 194.0</p>
<p>40 Skott</p> 	<p>40 Skott</p> 	<p>21: 9.6 ←</p> <p>22: 10.7x ↘</p> <p>23: 9.5 ↘</p> <p>24: 10.9x ↘</p> <p>25: 10.0 ↘</p> <p>26: 10.4x ↘</p> <p>27: 10.4x ↘</p> <p>28: 10.5x ↗</p> <p>29: 10.1 ↙</p> <p>30: 9.9 ↑</p> <hr/> <p>Serie 97.0</p> <p>Total 291.0</p>
<p>40 Skott</p>	<p>40 Skott</p>	<p>31: 9.6 ↑</p> <p>32: 10.7x ↗</p> <p>33: 10.2x ↘</p> <p>34: 10.3x ↘</p> <p>35: 10.5x ↘</p> <p>36: 9.9 ↘</p> <p>37: 10.3x →</p> <p>38: 10.6x ↘</p> <p>39: 10.2x ↘</p> <p>40: 10.8x →</p> <hr/> <p>Serie 98.0</p> <p>Total 389.0</p>

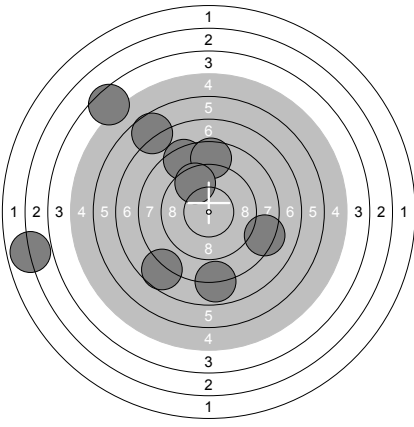
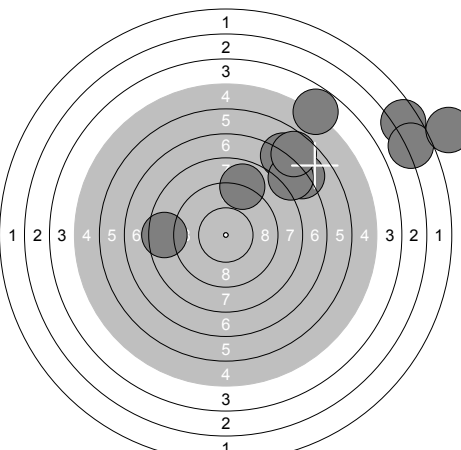
Prov 	40 Skott 1: 8.3 → 2: 7.9 ↓ 3: 7.7 ↙ 4: 2.9 ← 5: 0.0 → 6: 8.4 ↗ 7: 8.6 ↑ 8: 9.5 ↗ 9: 4.5 ↖ 10: 6.7 ↖ Serie 59.0 Total 0.0	 1: 8.5 ← 2: 8.9 ↗ 3: 2.5 ↗ 4: 7.1 ↗ 5: 7.0 ↗ 6: 2.7 ↗ 7: 4.8 ↗ 8: 1.0 → 9: 7.5 ↗ 10: 6.7 ↗ Serie 52.0 Total 52.0
---	--	--

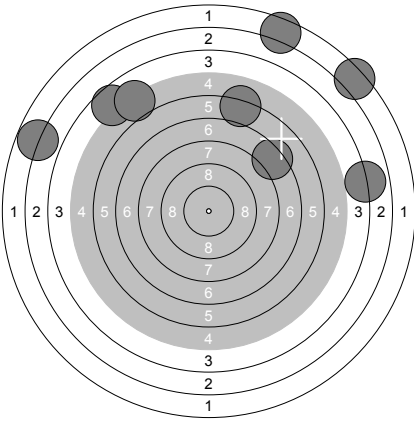
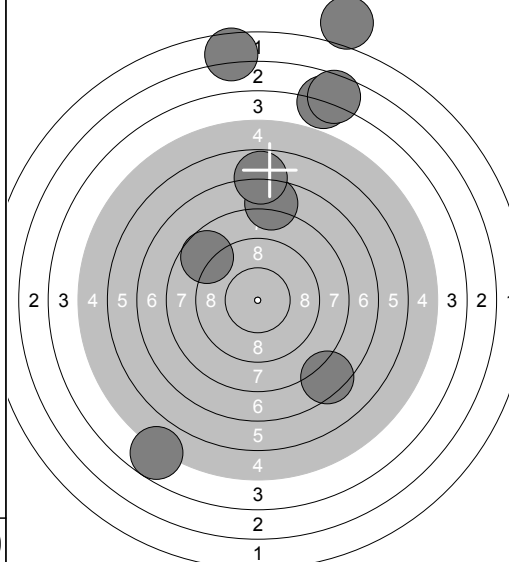
40 Skott 	40 Skott 11: 4.7 ↖ 12: 6.1 ↑ 13: 2.8 ← 14: 5.1 ↖ 15: 4.0 → 16: 0.0 → 17: 7.3 ↗ 18: 2.3 ↗ 19: 0.0 → 20: 2.5 ↑ Serie 32.0 Total 84.0	 21: 7.6 ↑ 22: 2.6 ↑ 23: 4.7 ↙ 24: 7.4 ↘ 25: 3.9 ↑ 26: 3.6 ↑ 27: 1.1 ↑ 28: 8.7 ↖ 29: 6.8 ↑ 30: 0.0 ↑ Serie 41.0 Total 125.0
--	--	---

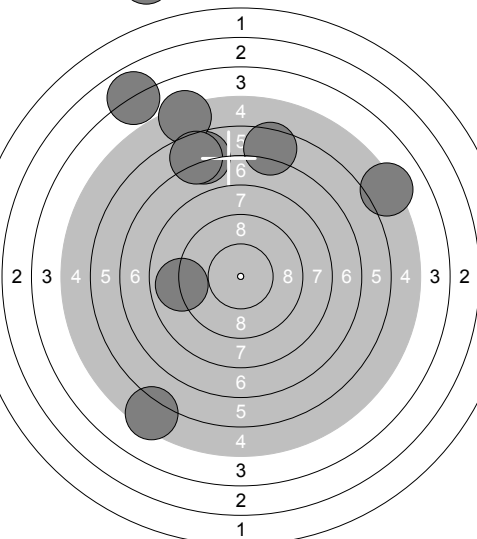
40 Skott 	31: 5.2 ↗ 32: 8.9 ← 33: 6.7 ↑ 34: 6.5 ↑ 35: 5.4 ↙ 36: 0.0 ↑ 37: 5.2 ↑ 38: 6.6 ↖ 39: 3.9 ↖ 40: 0.0 ↑ Serie 44.0 Total 169.0	
--	---	--

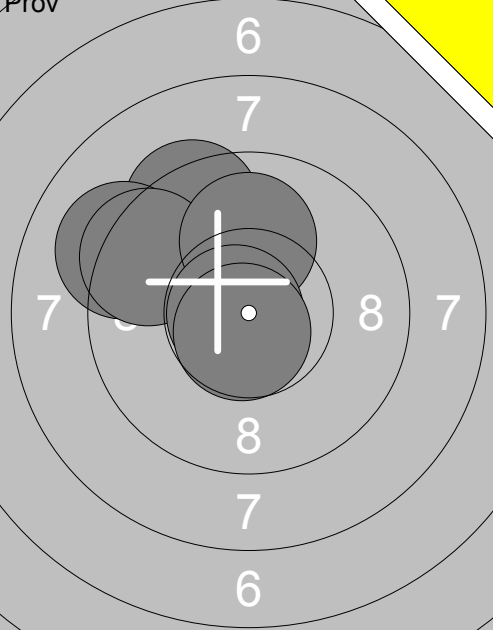
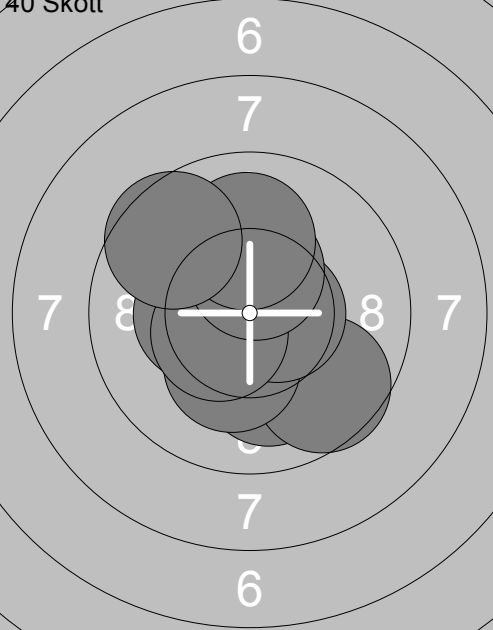
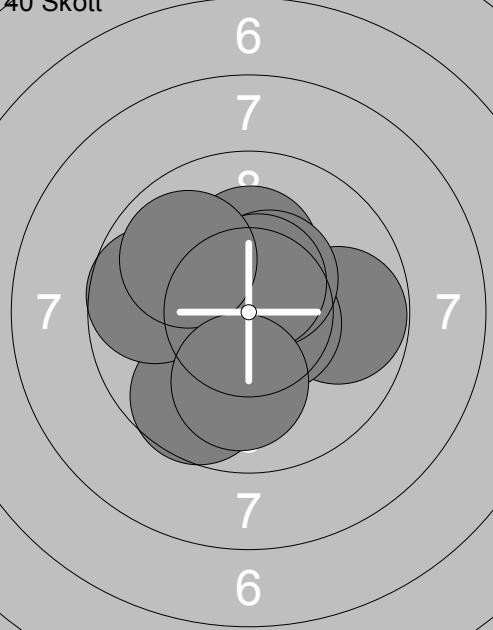
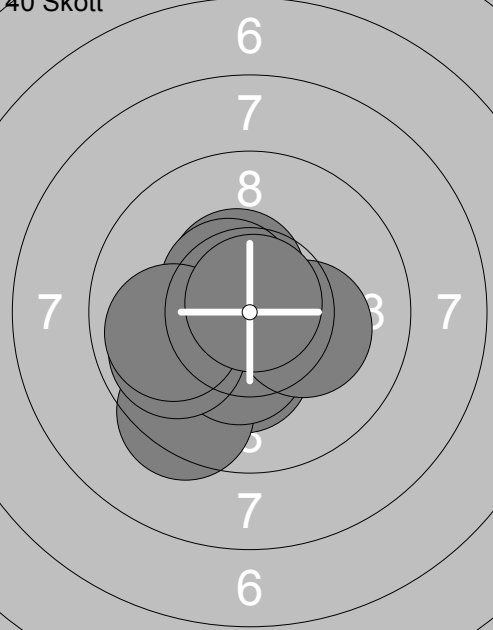
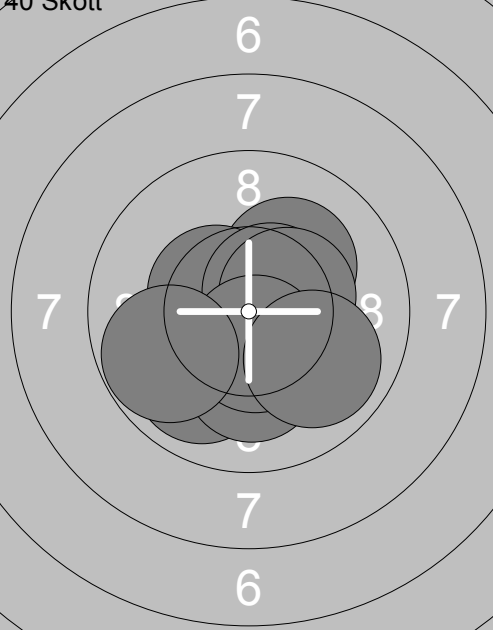
<p>Prov</p>  <p style="text-align: center;">6 7 8 7 6</p>	<p>1: 9.4 ↗ 2: 9.1 ↖ 3: 10.2x↗ 4: 9.4 ↖ 5: 10.0 ↑ 6: 10.8x← 7: 10.7x↓</p> <p>Serie 67.0 Total 0.0</p>	<p>40 Skott</p>  <p style="text-align: center;">6 7 8 7 6</p> <p>8: 10.1 ↓ 9: 10.3x← 10: 9.6 ↖</p> <p>Serie 98.0 Total 98.0</p>
<p>40 Skott</p>  <p style="text-align: center;">6 7 8 7 6</p>	<p>11: 10.2x↗ 12: 9.8 → 13: 10.5x↖ 14: 10.6x↗ 15: 9.7 ↓ 16: 10.4x↗ 17: 9.7 ← 18: 10.5x↗ 19: 9.9 ↖ 20: 10.0 ↓</p> <p>Serie 96.0 Total 194.0</p>	<p>40 Skott</p>  <p style="text-align: center;">6 7 8 7 6</p> <p>21: 10.6x← 22: 10.3x↓ 23: 10.5x↗ 24: 10.5x↖ 25: 9.4 ↓ 26: 10.4x↓ 27: 9.9 ← 28: 9.9 ← 29: 10.2x↗ 30: 10.8x↗</p> <p>Serie 97.0 Total 291.0</p>
<p>40 Skott</p>  <p style="text-align: center;">6 7 8 7 6</p>	<p>31: 10.2x↗ 32: 10.6x← 33: 9.9 ↓ 34: 10.5x← 35: 10.6x↗ 36: 10.1 ↓ 37: 10.4x↗ 38: 10.5x↓ 39: 9.9 ↘ 40: 9.8 ↖</p> <p>Serie 97.0 Total 388.0</p>	

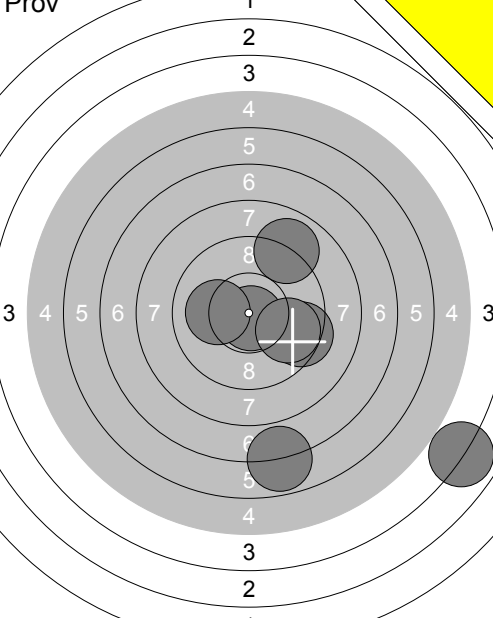
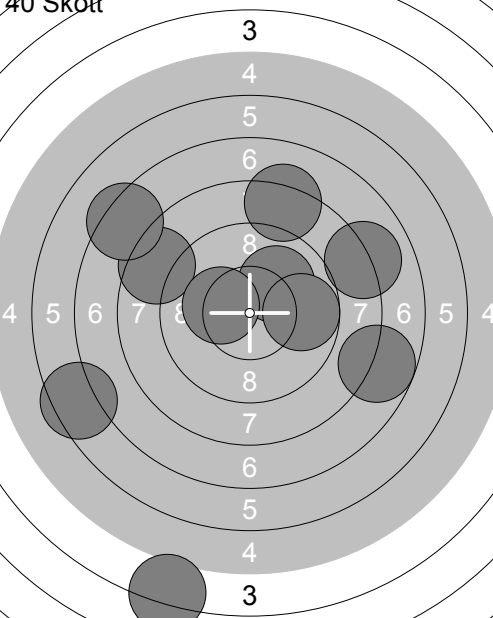
<p>Prov</p> 	<p>1: 3.9 ↘ 2: 6.8 ↓ 3: 10.8x↓ 4: 9.4 → 5: 9.0 ↗ 6: 10.1← 7: 9.8 →</p>	<p>40 Skott</p> 		<p>1: 10.0 ↗ 2: 4.1 ↓ 3: 7.7 → 4: 6.5 ← 5: 9.8 → 6: 8.0 ↗ 7: 8.3 ↑ 8: 8.5 ← 9: 10.3x↘ 10: 7.3 ↖</p>	
Serie 56.0				Serie 77.0	
Total 0.0				Total 77.0	

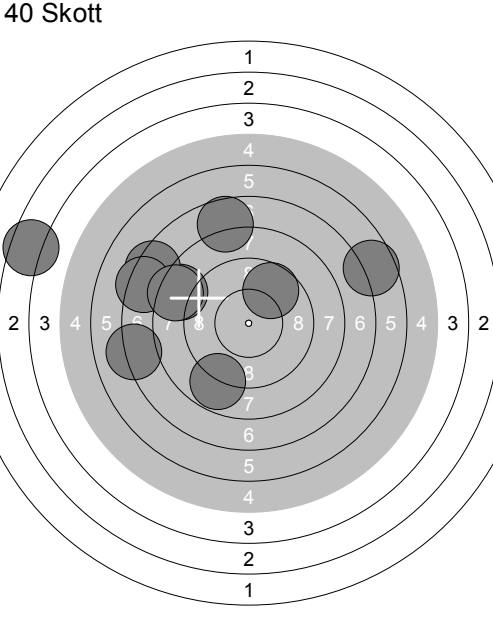
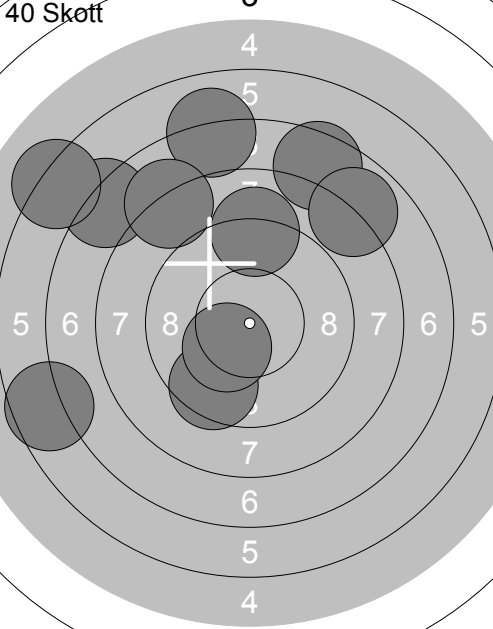
<p>40 Skott</p> 	<p>11: 6.6 → 12: 8.8 ↓ 13: 8.5 ← 14: 7.4 ↖ 15: 9.7 ↗ 16: 7.7 ↑ 17: 7.3 ← 18: 7.1 ← 19: 8.4 ← 20: 3.5 ←</p>	<p>40 Skott</p> 		<p>21: 7.2 ↖ 22: 9.1 ↑ 23: 7.0 ↑ 24: 9.5 ↓ 25: 6.6 ← 26: 10.3x↘ 27: 7.5 ↑ 28: 6.2 ↖ 29: 7.9 ↗ 30: 8.1 ↖</p>	
Serie 70.0				Serie 76.0	
Total 147.0				Total 223.0	

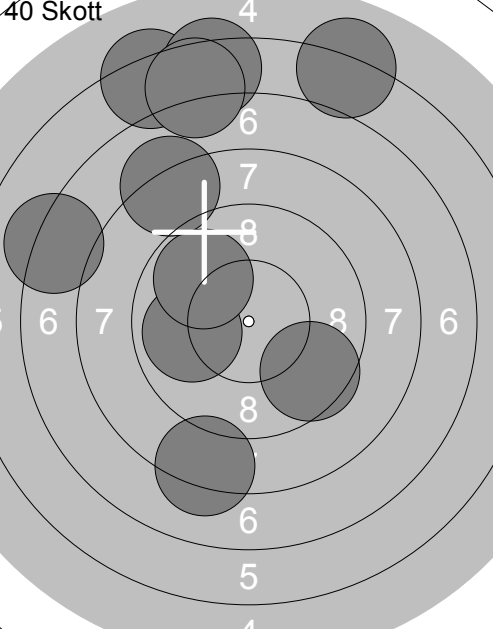
<p>40 Skott</p> 	<p>31: 8.2 ↓ 32: 9.5 ↘ 33: 9.9 ← 34: 9.8 ↖ 35: 6.3 ↗ 36: 7.2 ↖ 37: 6.3 ↑ 38: 8.1 ↖ 39: 6.6 ↑ 40: 6.1 ↗</p>			
Serie 74.0				
Total 297.0				