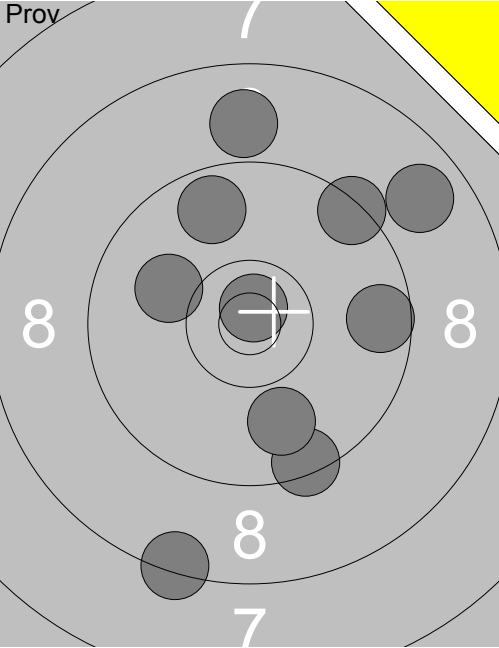
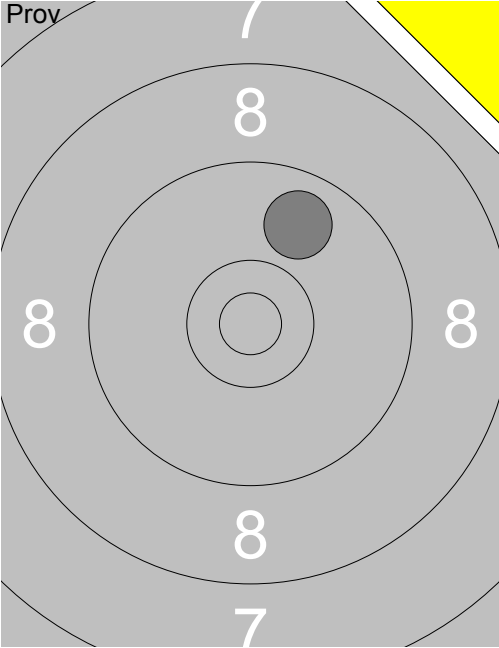
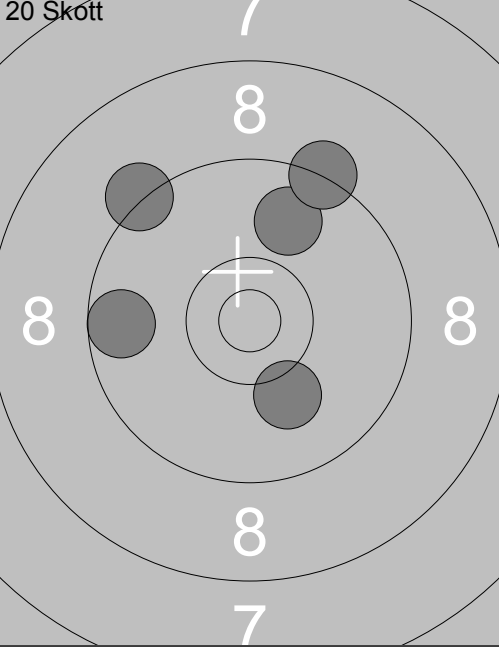
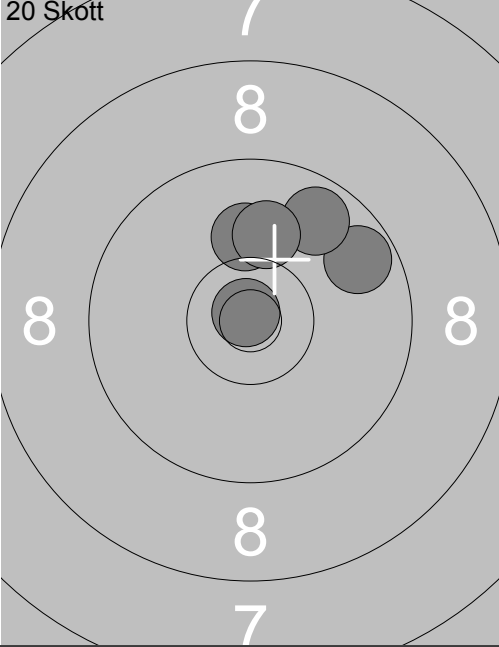
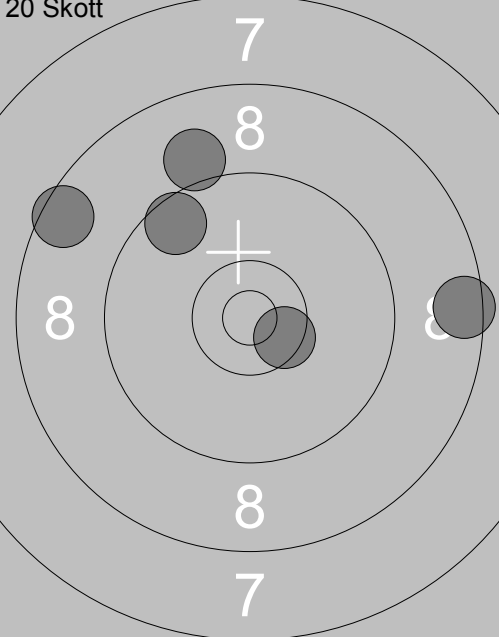
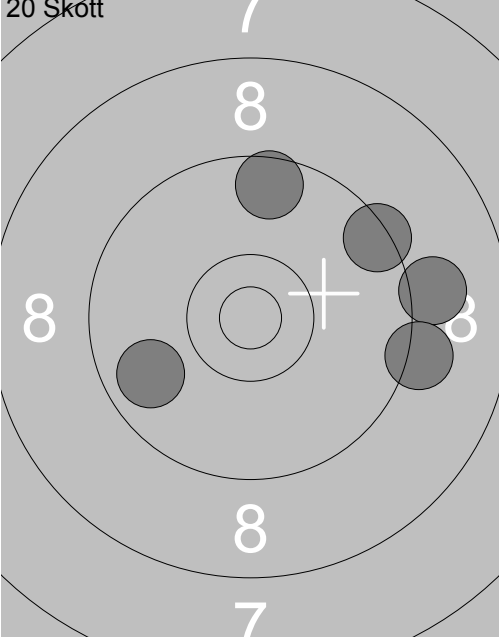
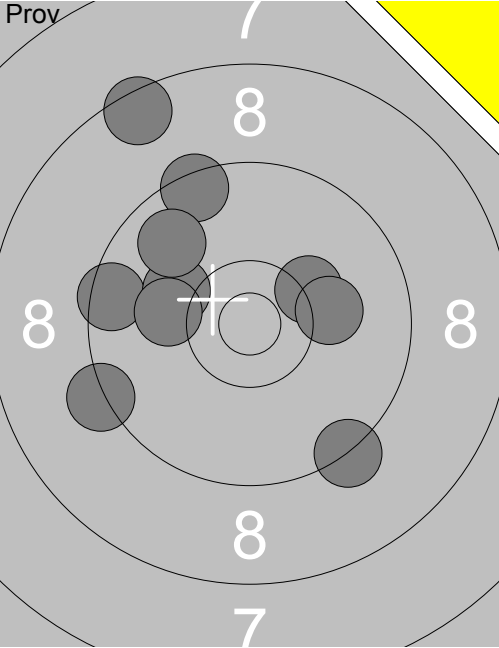
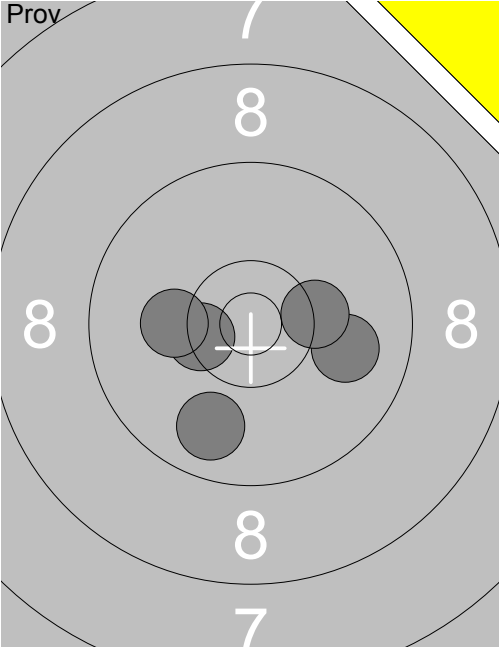
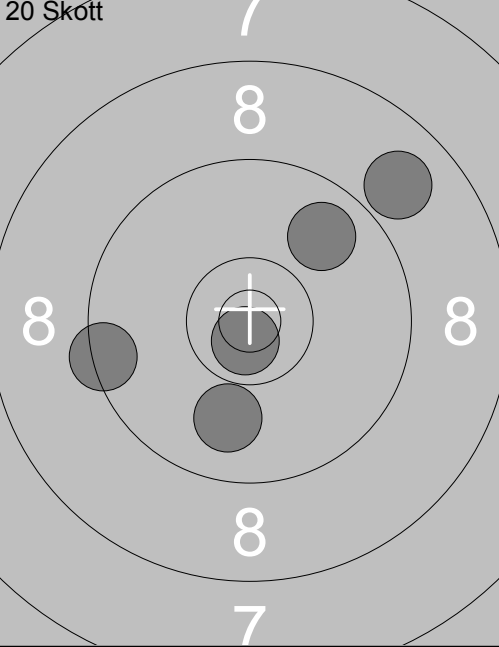
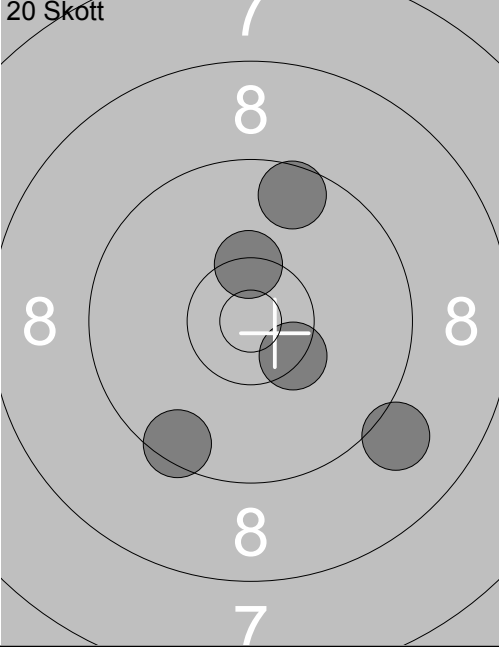
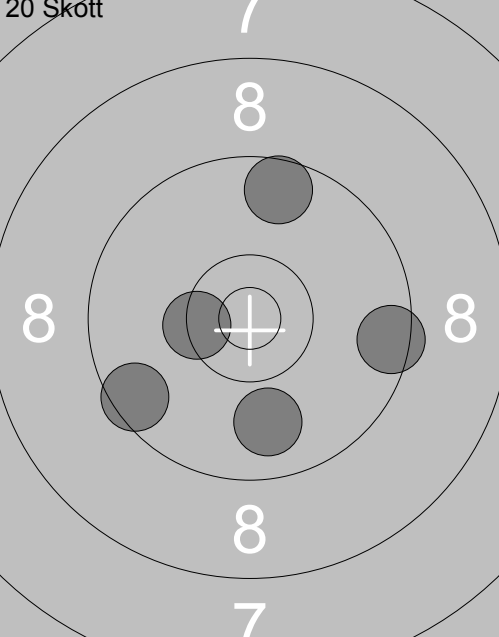
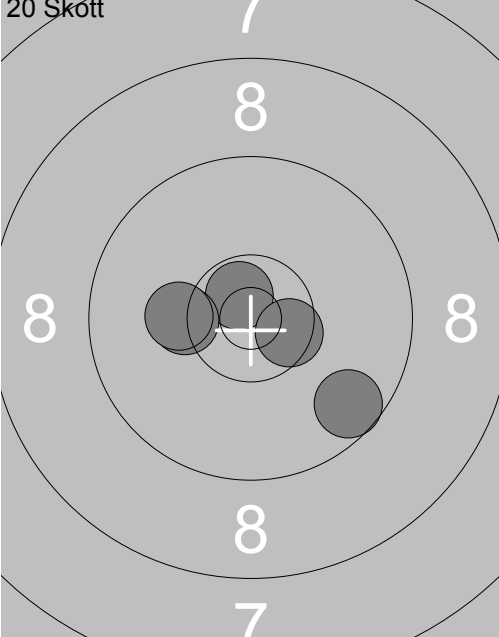
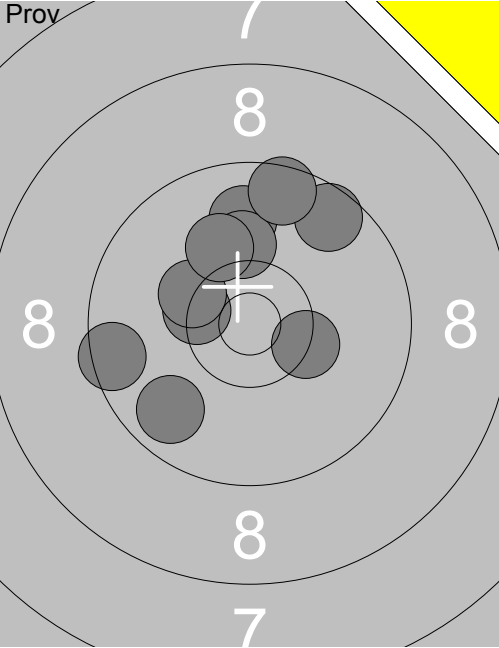
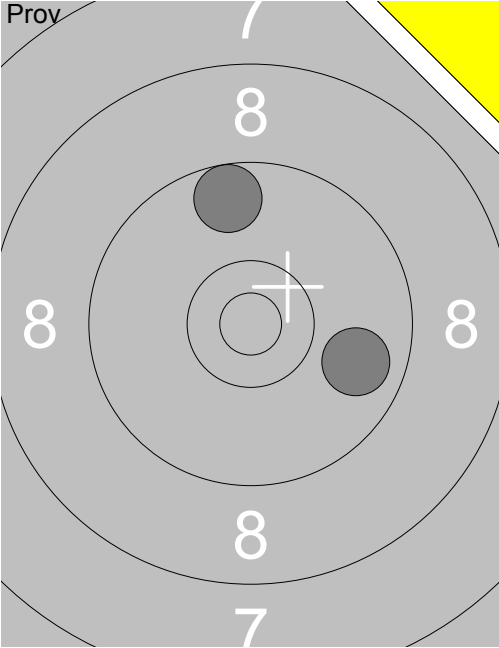
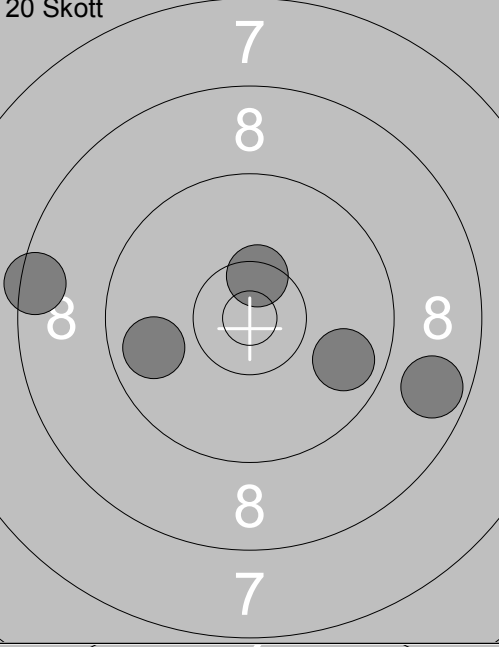
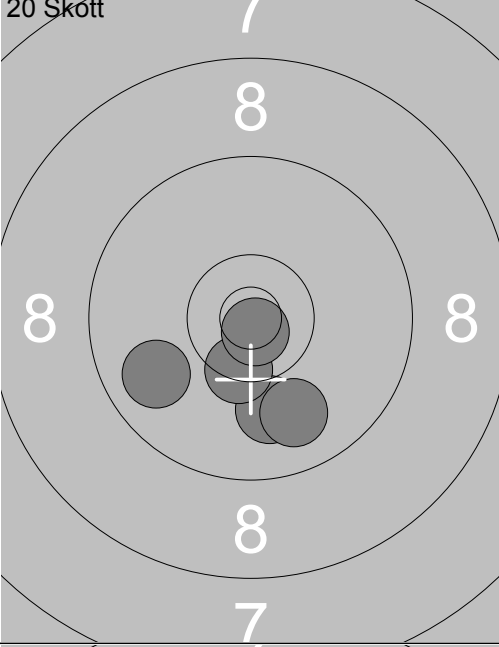
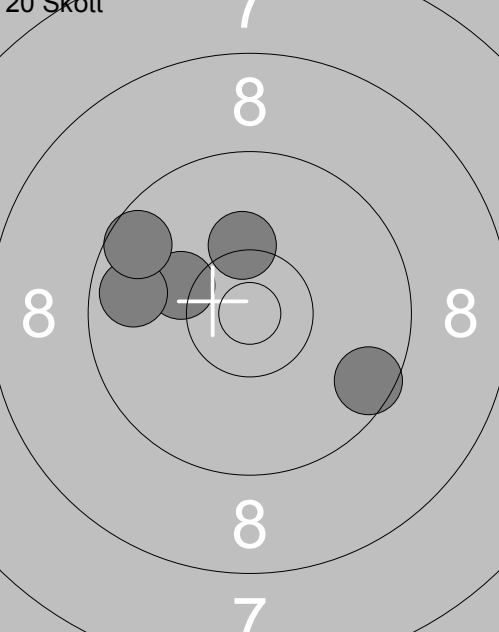
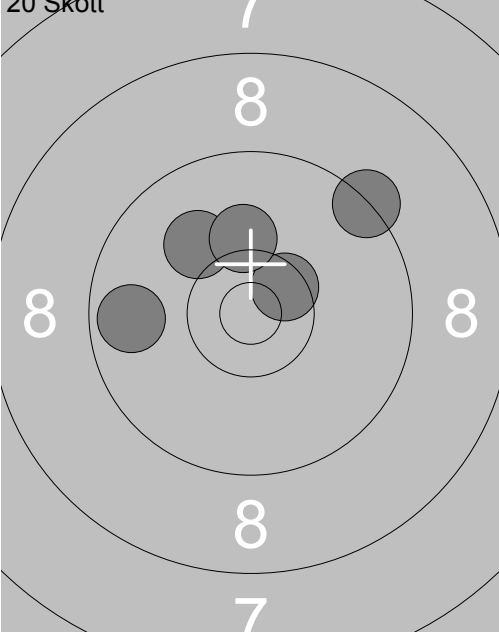
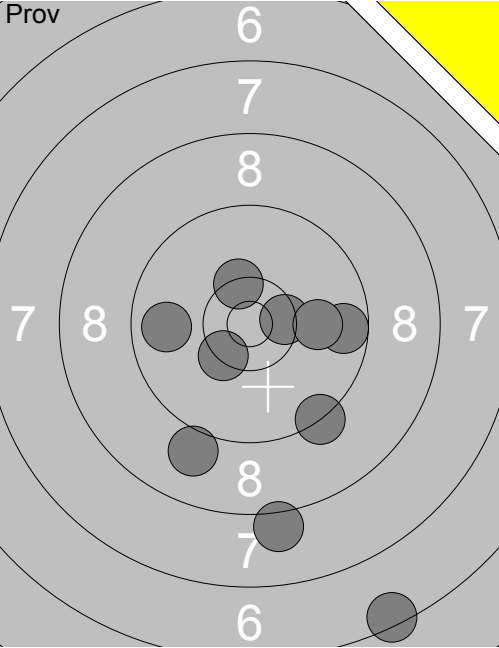
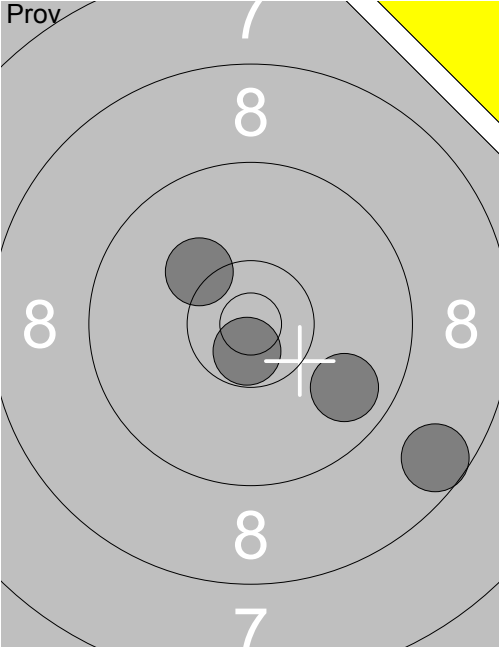
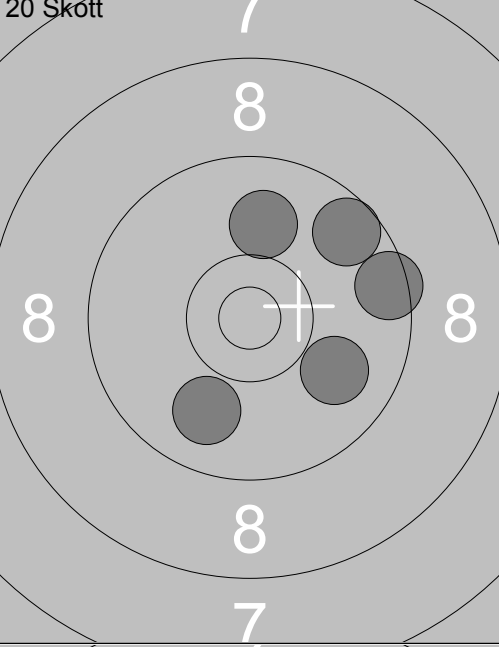
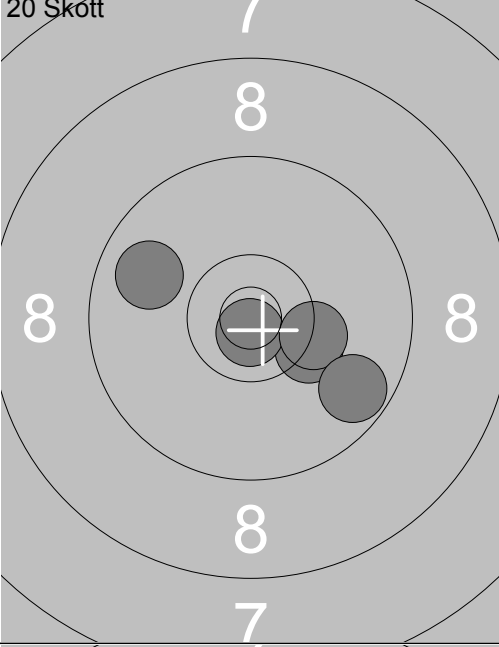
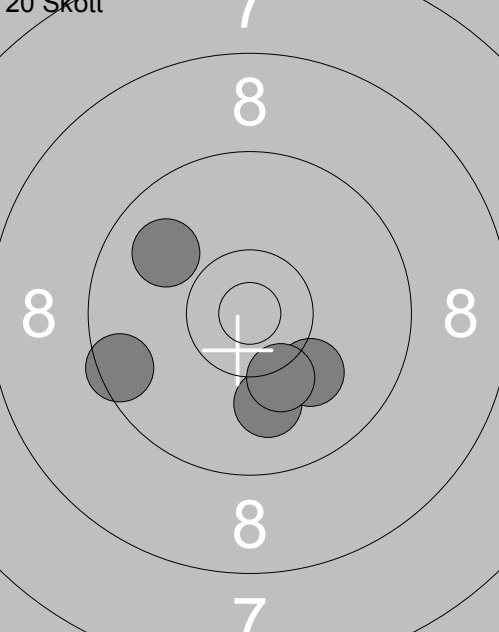
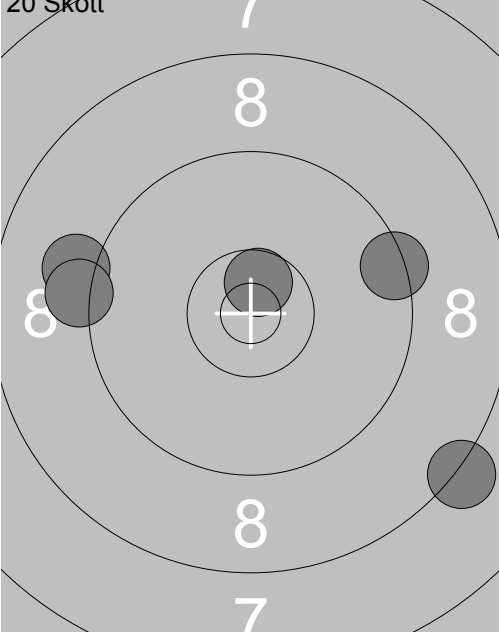
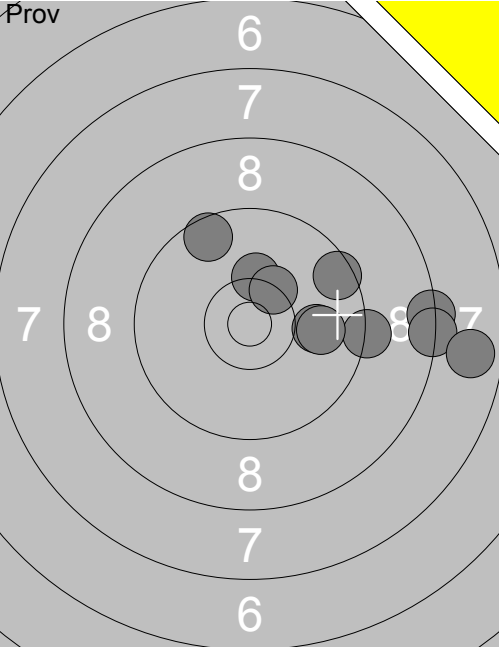
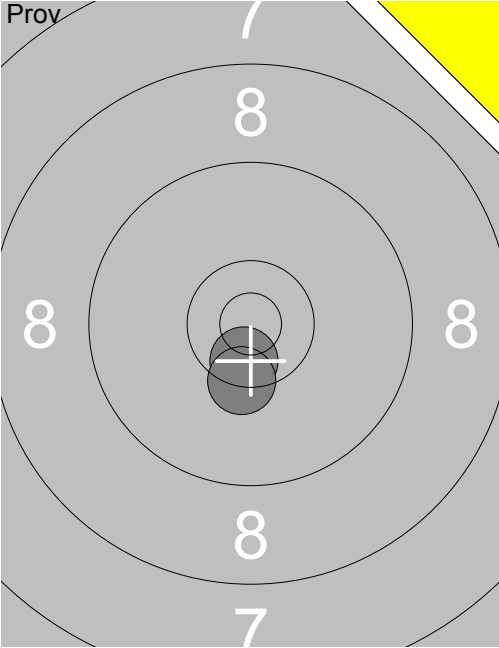
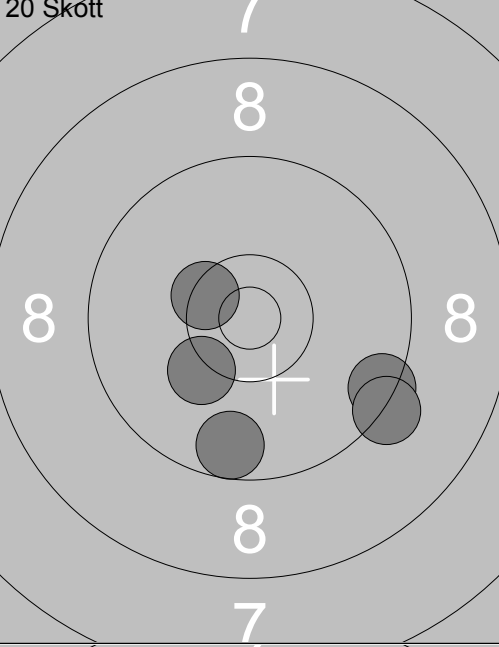
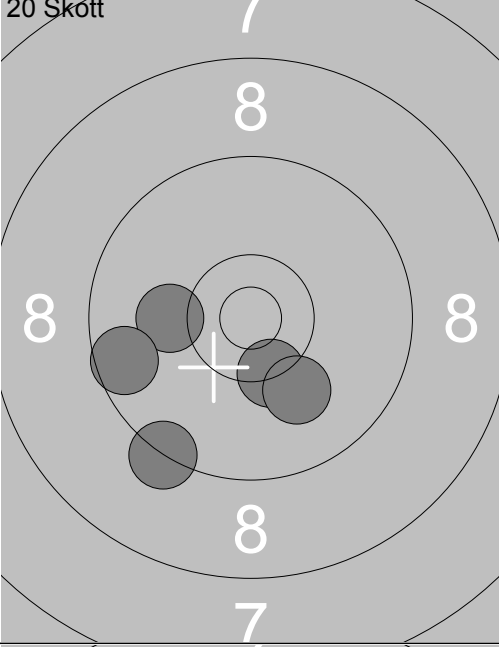
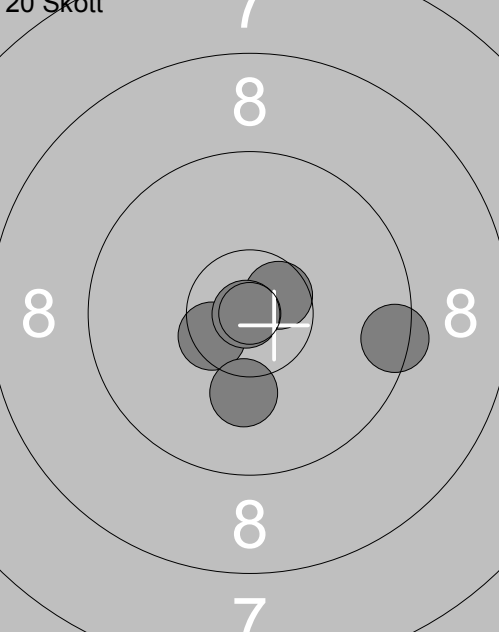
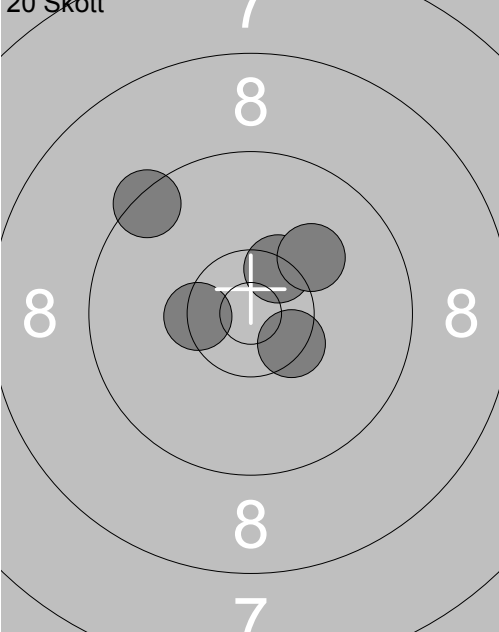

Skjutlag	Tavla	Dan-Ivan Karlsson				
1	1	Vindeln		Ramselefors	Vet-L	Vb
11.07.2017		Tavelträffen Korthåll 2017		Ramselefors SKF		
	1: 9.4 ↓		11: 9.8 ↗			
	2: 8.8 ↗					
	3: 9.9 ↓					
	4: 10.8x↗					
	5: 10.1 ↖					
	6: 8.9 ↑					
	7: 8.4 ↓					
	8: 9.4 ↗					
	9: 9.6 →					
	10: 9.7 ↑					
	Serie 89.0		Serie 9.0			
	Total 0.0		Total 0.0			
	1: 9.6 ←		6: 10.1 ↑			
	2: 9.3 ↖		7: 9.7 ↗			
	3: 9.9 ↑		8: 9.7 ↗			
	4: 9.3 ↗		9: 10.1 ↑			
	5: 10.1 ↓		10: 10.9x↘			
	Serie 46.0		Serie 48.0			
	Total 46.0		Total 94.0			
	11: 8.5 →		16: 9.1 →			
	12: 9.1 ↑		17: 9.2 →			
	13: 9.6 ↖		18: 9.4 ↗			
	14: 8.5 ↖		19: 9.8 ↖			
	15: 10.5x↘		20: 9.6 ↑			
	Serie 44.0		Serie 45.0			
	Total 138.0		Total 183.0			

Skjuttag	Tavla	Alf Edin		Vet-L	No
1	2				
Vindeln	Ale				
11.07.2017	Tavelträffen Korthåll 2017		Ramselefors SKF		
Prov		1: 9.5 ← 2: 10.1 ← 3: 8.5 ↗ 4: 9.4 ↗ 5: 10.1 ← 6: 9.8 ↗ 7: 10.3 ↗ 8: 9.3 ↓ 9: 10.1 → 10: 9.3 ← Serie 93.0 Total 0.0	Prov		11: 9.8 ↓ 12: 10.0 → 13: 10.4x ← 14: 10.3x → 15: 10.2 ← Serie 49.0 Total 0.0
20 Skott		1: 9.4 ← 2: 10.7x ↓ 3: 9.9 ↓ 4: 8.9 ↗ 5: 9.8 ↗ Serie 45.0 Total 45.0	20 Skott		6: 10.4x ↑ 7: 9.6 ↗ 8: 10.4x ↘ 9: 9.5 ↓ 10: 9.1 ↓ Serie 47.0 Total 92.0
20 Skott		11: 10.4x ← 12: 9.9 ↓ 13: 9.6 ↗ 14: 9.5 → 15: 9.5 ← Serie 46.0 Total 138.0	20 Skott		16: 10.7x ↘ 17: 10.3 ← 18: 10.5x → 19: 9.6 ↓ 20: 10.2 ← Serie 49.0 Total 187.0

Skjuttag	Tavla	Christer Vredin			
1	4	Vindeln	Umeå	Sen-L	Vb
11.07.2017		Tavelträffen Korthåll 2017	Ramselefors SKF		
Prov		1: 9.6 ↗ 2: 9.8 ↘ 3: 10.4 ✕ 4: 9.9 ↑ 5: 10.3 ✕ 6: 10.1 ↑ 7: 9.5 ↑ 8: 10.3 ✕ 9: 9.5 ← 10: 10.1 ↗	Prov		11: 9.6 ↑ 12: 9.8 ➡
		Serie 95.0 Total 0.0			Serie 18.0 Total 0.0
20 Skott		1: 10.5x ↗ 2: 9.8 ➡ 3: 9.8 ← 4: 8.7 ➡ 5: 8.5 ←	20 Skott		6: 9.8 ← 7: 10.0 ↓ 8: 9.9 ↓ 9: 10.4x ↓ 10: 10.8x ↓
		Serie 44.0 Total 44.0			Serie 48.0 Total 92.0
20 Skott		11: 10.2 ← 12: 9.7 ← 13: 9.6 ← 14: 9.6 ➡ 15: 10.3 ↑	20 Skott		16: 10.5x ↗ 17: 9.7 ← 18: 9.3 ↗ 19: 10.1 ↗ 20: 10.2 ↑
		Serie 47.0 Total 139.0			Serie 48.0 Total 187.0

Skjuttag	Tavla	Donald Johansson			
1	5	Ale		Vet-L	No
11.07.2017	Tavelträffen Korthåll 2017	Ramselefors SKF			
Prov		1: 6.4 ↓ 2: 8.1 ↓ 3: 10.5x → 4: 9.3 ↓ 5: 9.0 ↓ 6: 9.6 → 7: 10.0 → 8: 10.4x ↙ 9: 9.8 ← 10: 10.4x ↗	Prov		11: 10.2 ↗ 12: 10.7x ↓ 13: 8.6 ↓ 14: 9.8 ↓
		Serie 90.0		Serie 37.0	
		Total 0.0		Total 0.0	
20 Skott		1: 9.6 ↗ 2: 10.0 ↑ 3: 9.9 ↘ 4: 9.5 → 5: 9.9 ↓	20 Skott		6: 9.8 ← 7: 10.3 ↘ 8: 10.8x ↓ 9: 10.3x → 10: 9.7 ↓
		Serie 46.0		Serie 48.0	
		Total 46.0		Total 94.0	
20 Skott		11: 9.5 ← 12: 10.0 ↓ 13: 10.1 ↘ 14: 9.9 ↖ 15: 10.2 ↓	20 Skott		16: 9.1 ← 17: 9.2 ← 18: 8.2 ↓ 19: 10.6x ↗ 20: 9.4 →
		Serie 48.0		Serie 45.0	
		Total 142.0		Total 187.0	

Skjutlag	Tavla	Emil Björndahl	
1	6	Vindeln	Kvistbro
11.07.2017	Tavelträffen Korthåll 2017	Jun-L	Ör
Prov	Ramselefors SKF		
	1: 8.4 → 2: 9.3 → 3: 8.3 → 4: 10.3 ↑ 5: 9.5 ↗ 6: 10.0 → 7: 7.8 → 8: 9.9 → 9: 10.4x ↗ 10: 9.6 ↖ Serie 89.0 Total 0.0		11: 10.6x ↓ 12: 10.4x ↓ Serie 20.0 Total 0.0
20 Skott 	1: 9.6 ↓ 2: 9.4 → 3: 10.2 ↓ 4: 9.3 ↘ 5: 10.4x ↘ Serie 47.0 Total 47.0	20 Skott 	6: 10.3x ↓ 7: 10.1 ↓ 8: 10.1 ← 9: 9.3 ↓ 10: 9.6 ← Serie 48.0 Total 95.0
20 Skott 	11: 10.5x ↘ 12: 10.6x ↗ 13: 10.9x ← 14: 10.1 ↓ 15: 9.5 → Serie 49.0 Total 144.0	20 Skott 	16: 9.4 ↖ 17: 10.4x ← 18: 10.4x ↘ 19: 10.4x ↗ 20: 10.1 ↗ Serie 49.0 Total 193.0

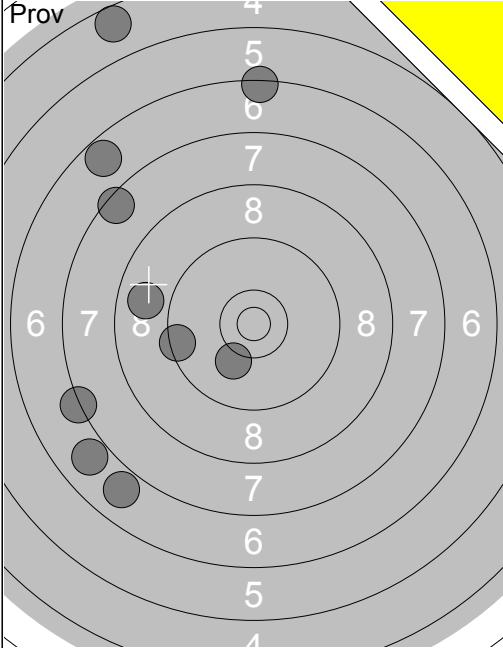
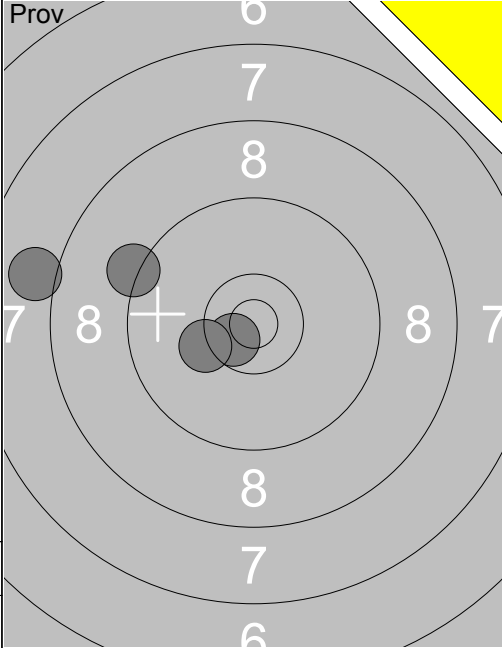
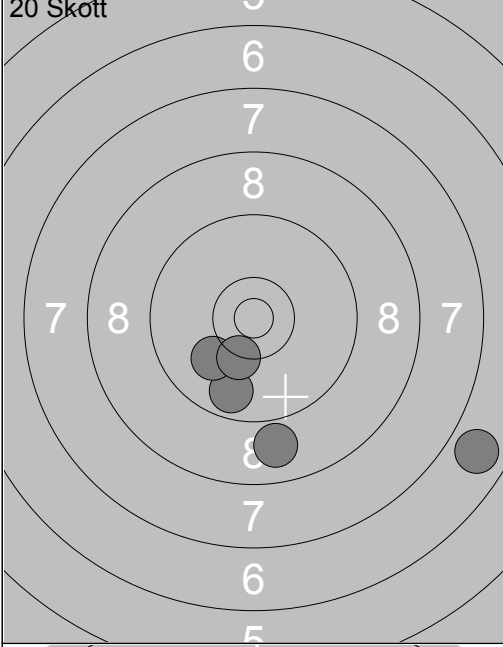
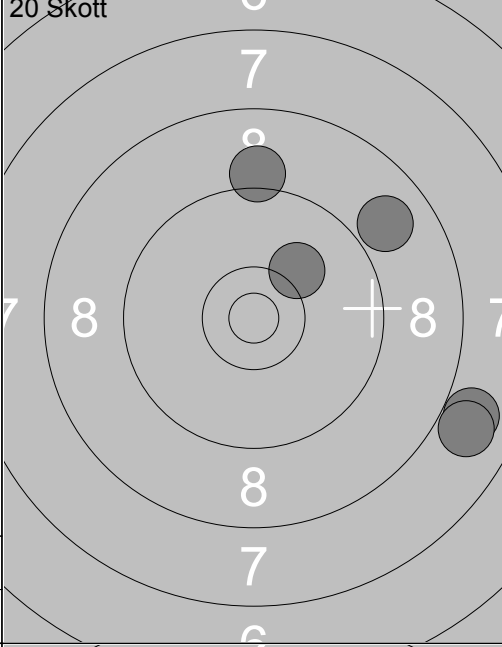
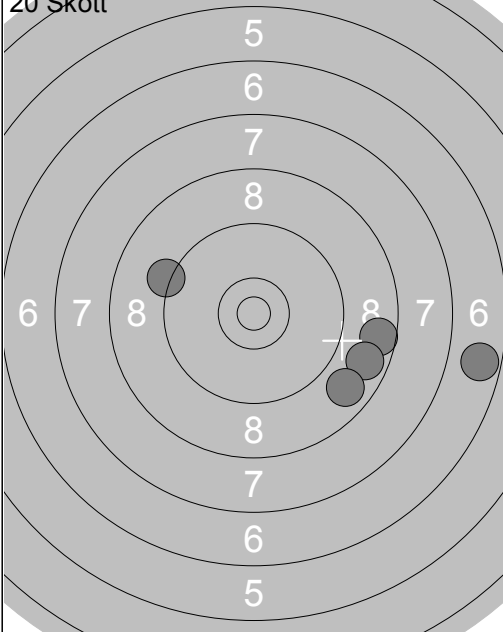
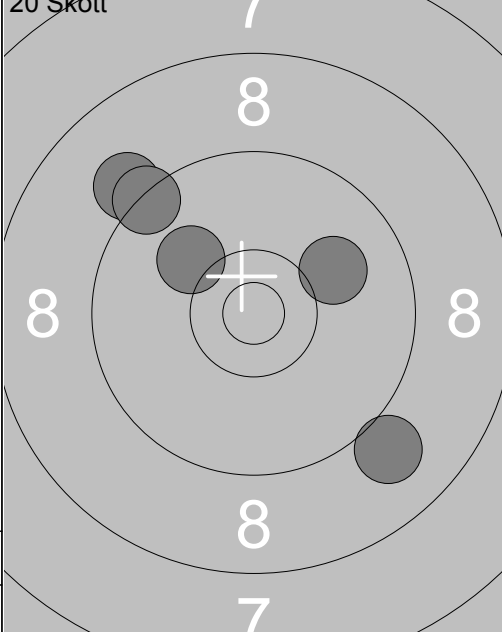
Skjuttag	Tavla	Emma Eriksson			
1	7	Vindeln	Ramselefors	Jun-L	Vb
11.07.2017	Tavelträffen Korthåll 2017	Ramselefors SKF			
Prov		1: 6.4 ↑ 2: 4.6 ↗ 3: 6.7 ↗ 4: 7.5 ↗ 5: 8.8 ← 6: 6.9 ↙ 7: 9.5 ← 8: 7.3 ← 9: 10.1 ↘ 10: 6.9 ↘	Prov		11: 9.2 ↙ 12: 8.0 ↙ 13: 10.6 ↘ 14: 10.3 ↙
	Serie 69.0			Serie 37.0	
	Total 0.0			Total 0.0	
20 Skott		1: 6.8 ➡ 2: 9.7 ↘ 3: 8.9 ↘ 4: 10.0 ↙ 5: 10.3 ↘	20 Skott		6: 9.1 ↑ 7: 8.9 ↗ 8: 7.9 ➡ 9: 10.1 ↗ 10: 7.9 ➡
	Serie 43.0			Serie 41.0	
	Total 43.0			Total 84.0	
20 Skott		11: 9.2 ↙ 12: 8.6 ➡ 13: 6.7 ➡ 14: 8.7 ➡ 15: 8.8 ↘	20 Skott		16: 9.0 ↘ 17: 9.1 ↗ 18: 10.0 ↗ 19: 10.1 ↗ 20: 9.4 ↗
	Serie 39.0			Serie 47.0	
	Total 123.0			Total 170.0	

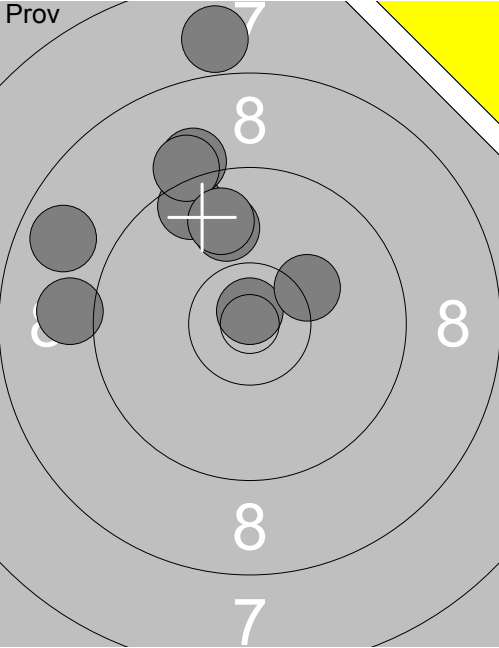
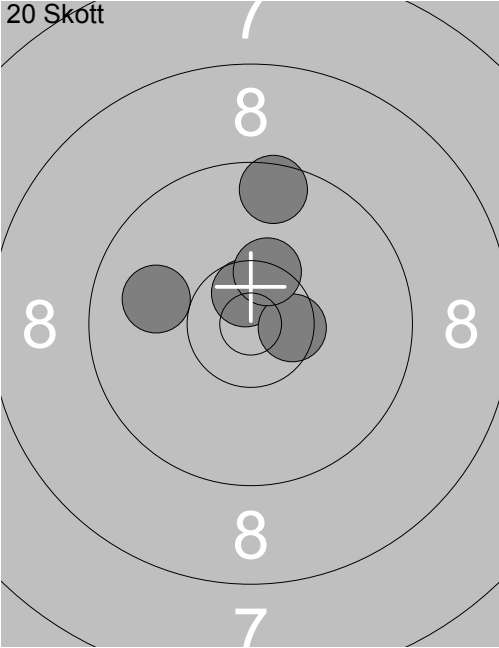
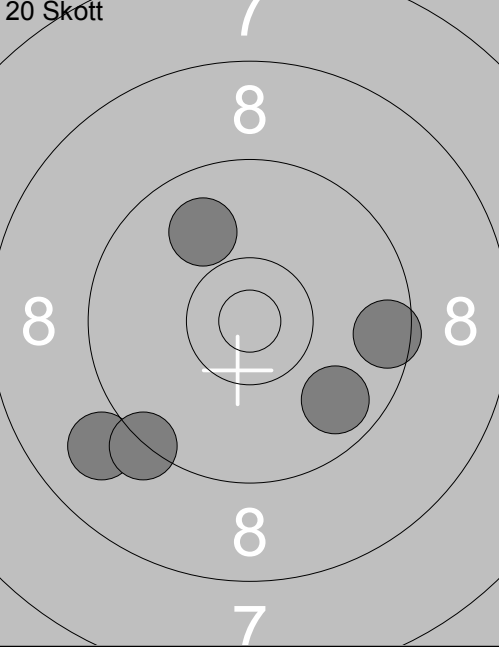
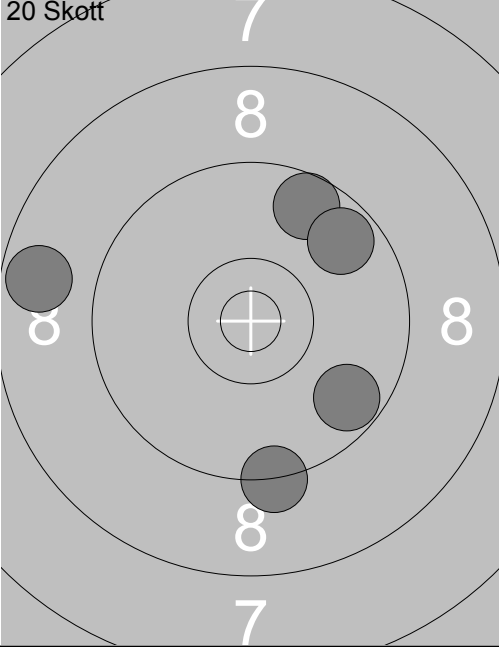
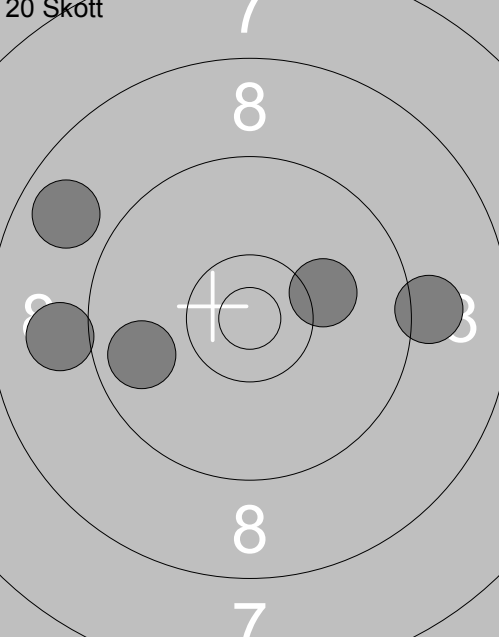
Skjutlag	Tavla	Emma Wallerström			
1	9	Vindeln	Umeå	Jun-L	Vb
11.07.2017		Tavelträffen Korthåll 2017	Ramselefors SKF		
Prov		1: 9.6 ↗ 2: 7.9 ↑ 3: 9.9 ↑ 4: 10.8x↑ 5: 9.1 ↑ 6: 9.2 ↑ 7: 9.8 ↑ 8: 8.8 ↖ 9: 9.0 ↖ 10: 10.2 ↗ Serie 89.0 Total 0.0	20 Skott		1: 10.6x↑ 2: 10.0↖ 3: 10.5x➤ 4: 10.4x↑ 5: 9.6 ↑ Serie 49.0 Total 49.0
20 Skott		6: 9.9 ↗ 7: 9.8 ↘ 8: 9.5 ➔ 9: 9.0 ↙ 10: 9.3 ↘ Serie 45.0 Total 94.0	20 Skott		11: 9.3 ↓ 12: 9.6 ↗ 13: 9.7 ↘ 14: 8.7 ↖ 15: 9.7 ↗ Serie 44.0 Total 138.0
20 Skott		16: 9.8 ↖ 17: 9.0 ↖ 18: 10.2➤ 19: 9.1 ➔ 20: 8.8 ↖ Serie 45.0 Total 183.0			

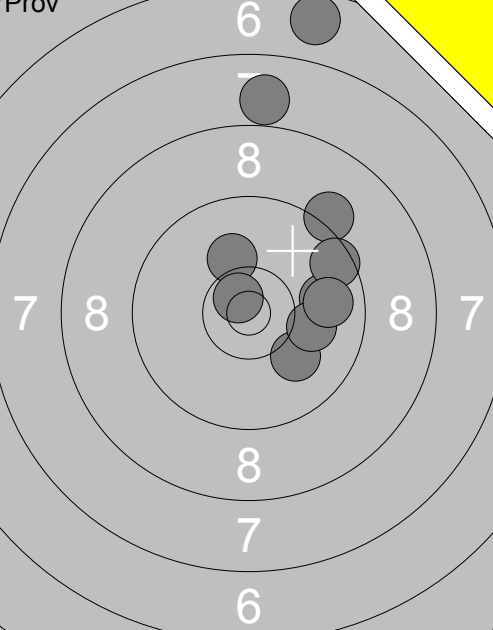
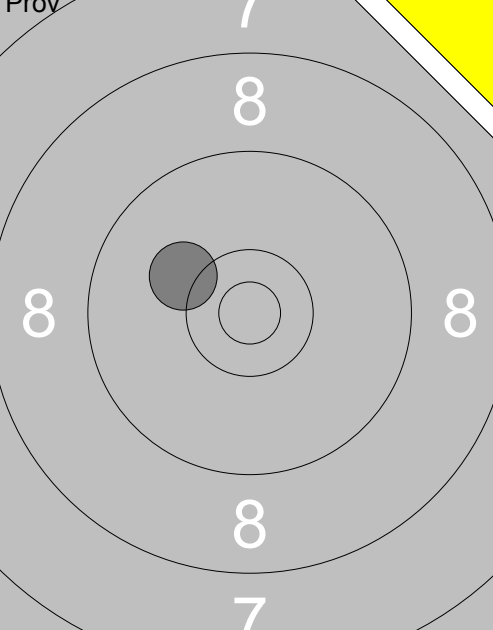
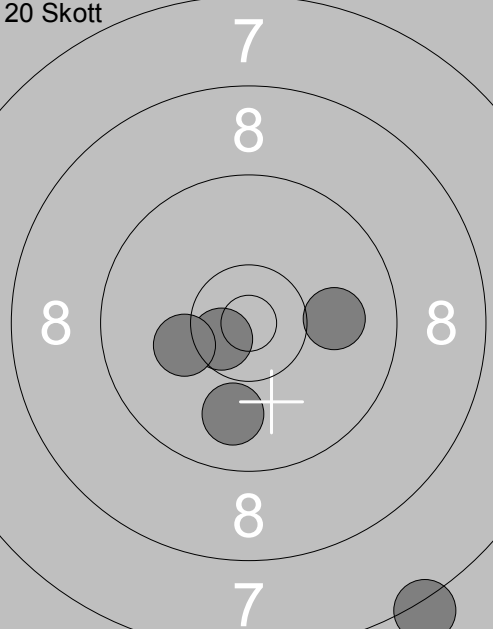
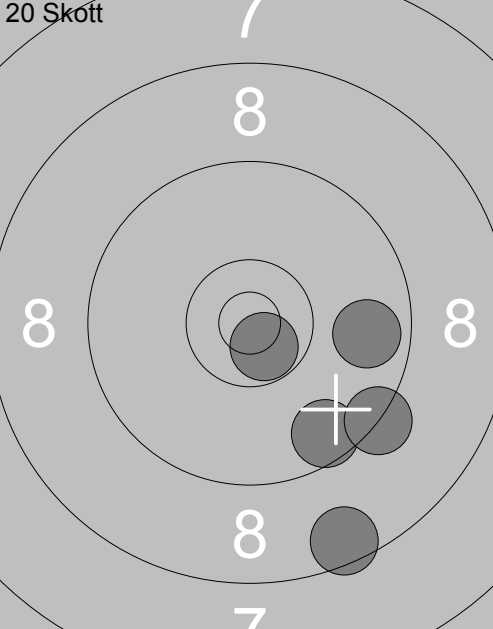
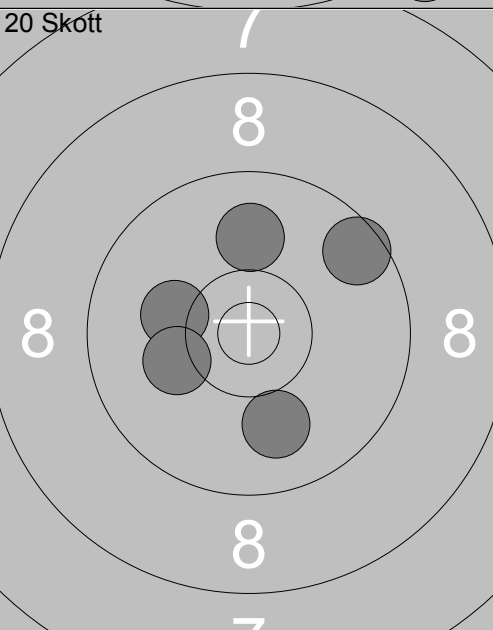
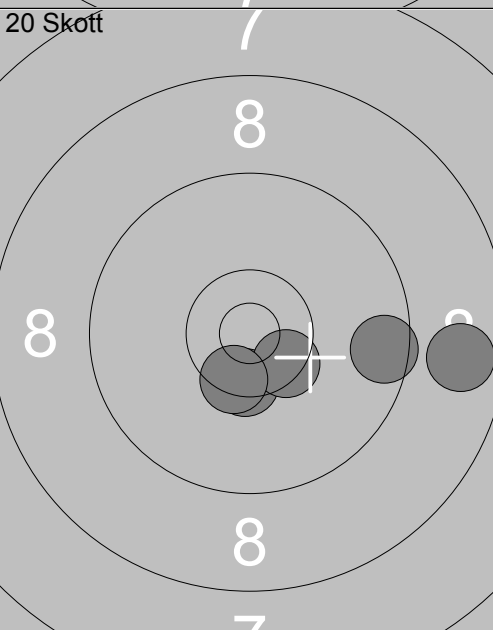
<p>Prov</p> 	<p>1: 6.7 ↑ 2: 7.9 ↑ 3: 10.1 ↑ 4: 9.9 → 5: 9.2 ↗ 6: 10.1 ↘ 7: 9.5 ↗ 8: 10.7x ↘ 9: 10.0 → 10: 9.8 →</p> <p>Serie 89.0 Total 0.0</p>	<p>Prov</p>  <p>11: 10.2 ↘</p> <p>Serie 10.0 Total 0.0</p>
<p>20 Skott</p> 	<p>1: 9.9 ↓ 2: 10.6x ↘ 3: 10.0 → 4: 10.2 ↙ 5: 7.2 ↓</p> <p>Serie 46.0 Total 46.0</p>	<p>20 Skott</p>  <p>6: 10.7x ↘ 7: 9.6 ↘ 8: 9.7 → 9: 8.5 ↓ 10: 9.3 ↘</p> <p>Serie 45.0 Total 91.0</p>
<p>20 Skott</p> 	<p>11: 9.6 ↗ 12: 10.2 ↙ 13: 10.0 ↓ 14: 10.2 ↙ 15: 10.0 ↑</p> <p>Serie 49.0 Total 140.0</p>	<p>20 Skott</p>  <p>16: 10.4x ↓ 17: 9.6 → 18: 10.5x ↘ 19: 8.8 → 20: 10.4x ↓</p> <p>Serie 47.0 Total 187.0</p>

	<p>1: 4.2 ↙ 2: 9.3 ↙ 3: 9.1 ↘ 4: 9.3 ↙ 5: 10.0 ↘ 6: 9.8 ↘ 7: 9.9 ↙ 8: 10.8 ↗ 9: 10.7 ↗ 10: 10.0 ↗</p> <p>Serie 89.0 Total 0.0</p>		<p>11: 9.8 → 12: 9.4 ↗ 13: 10.1 → 14: 10.5x → 15: 10.5x ↘</p> <p>Serie 48.0 Total 0.0</p>
<p>20 Skott</p>	<p>1: 10.0 ↘ 2: 10.7x → 3: 9.8 ↗ 4: 9.9 → 5: 9.5 →</p> <p>Serie 47.0 Total 47.0</p>	<p>20 Skott</p>	<p>6: 10.2 ← 7: 9.8 → 8: 10.5x ↗ 9: 10.8x ↗ 10: 9.4 →</p> <p>Serie 48.0 Total 95.0</p>
<p>20 Skott</p>	<p>11: 9.7 ↘ 12: 9.8 ↙ 13: 9.9 ↗ 14: 10.6x ↘ 15: 10.3x ↘</p> <p>Serie 47.0 Total 142.0</p>	<p>20 Skott</p>	<p>16: 10.4x ↘ 17: 10.3x ↗ 18: 10.6x ↘ 19: 10.2 ↗ 20: 10.2 ↗</p> <p>Serie 50.0 Total 192.0</p>

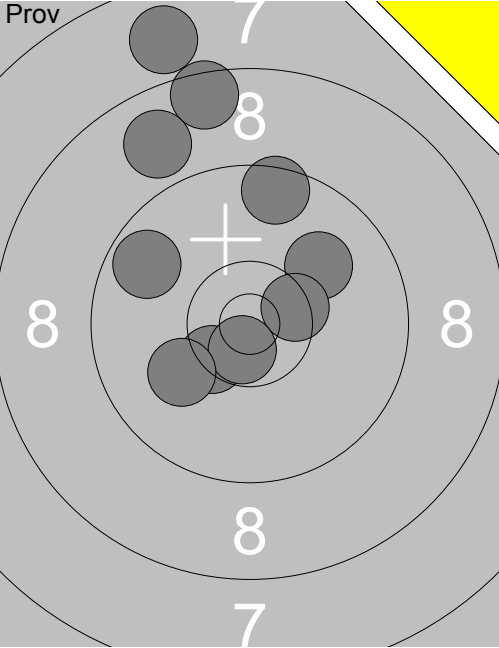
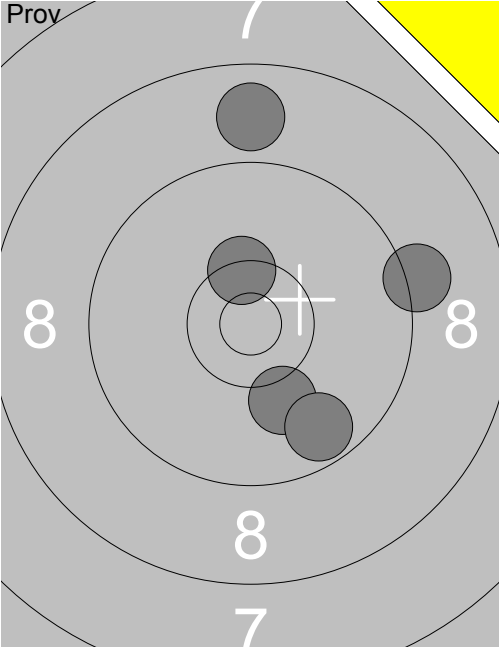
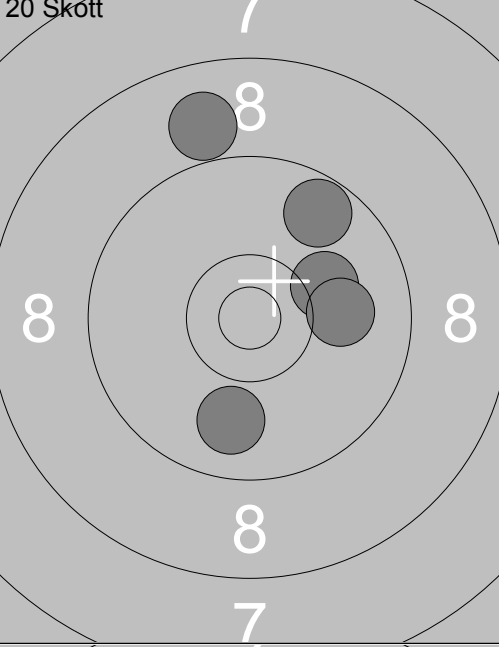
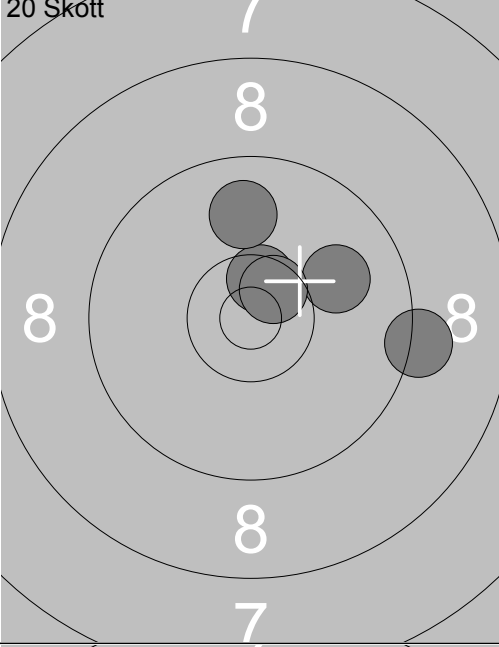
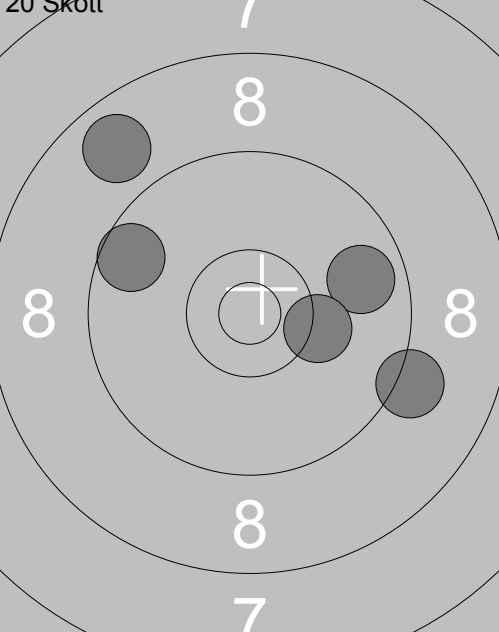
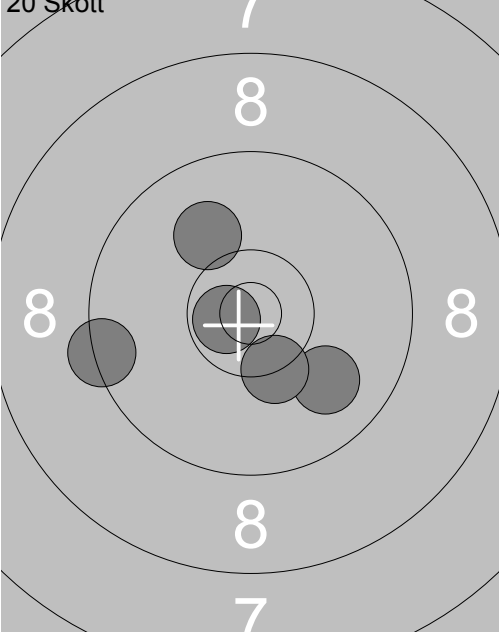
Skjutlag	Tavla	Henry Lindström		Vet-L	No
1	12				
Vindeln	I 19 / A 9				
11.07.2017	Tavelträffen Korthåll 2017	Ramselefors SKF			
Prov		1: 7.9 ↑ 2: 8.5 ↑ 3: 9.7 ↖ 4: 8.9 ↗ 5: 10.0 ↗ 6: 9.5 ↑ 7: 10.4x → 8: 10.4x ↘ 9: 10.7x ↘ 10: 10.1 ↙	Prov		11: 10.1 ↘ 13: 9.7 ↘ 14: 9.2 → 15: 10.4x ↗ 16: 8.8 ↑
	Serie 91.0		Serie 46.0		
	Total 0.0		Total 0.0		
20 Skott		1: 8.9 ↑ 2: 9.7 ↗ 3: 10.1 → 4: 10.0 → 5: 9.9 ↓	20 Skott		6: 10.5x ↗ 7: 10.0 → 8: 9.9 ↑ 9: 9.2 → 10: 10.6x ↗
	Serie 46.0		Serie 48.0		
	Total 46.0		Total 94.0		
20 Skott		11: 9.6 ↖ 12: 9.2 → 13: 8.8 ↗ 14: 9.8 → 15: 10.2 →	20 Skott		16: 9.9 ↘ 17: 10.3x ↘ 18: 9.4 ← 19: 10.0 ↗ 20: 10.7x ↘
	Serie 45.0		Serie 48.0		
	Total 139.0		Total 187.0		

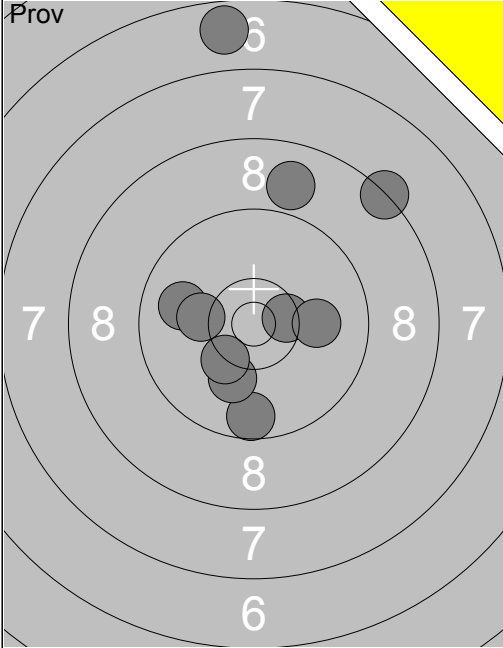
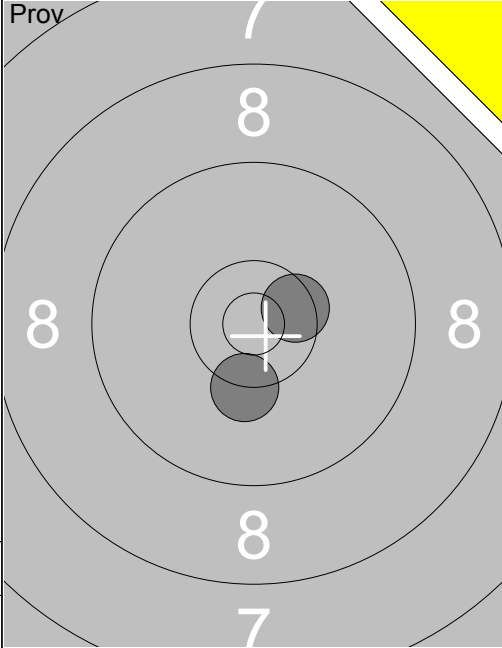
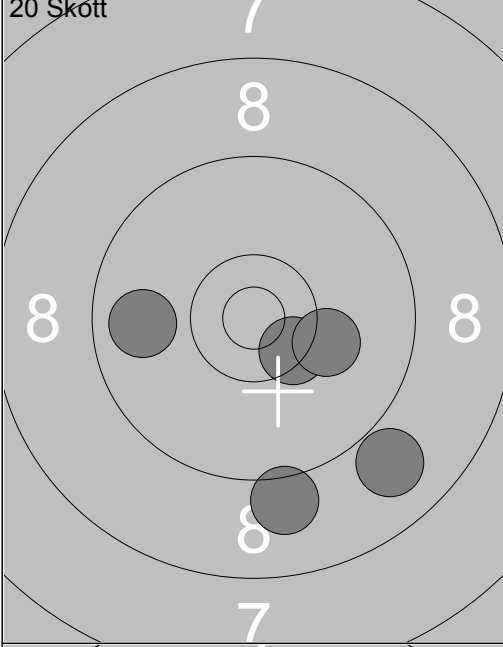
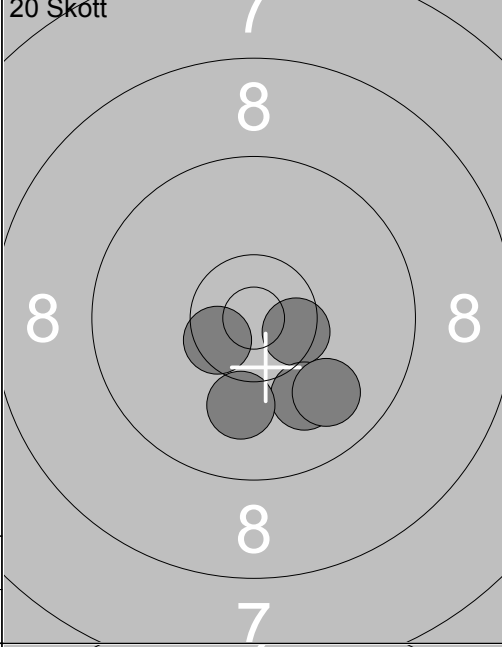
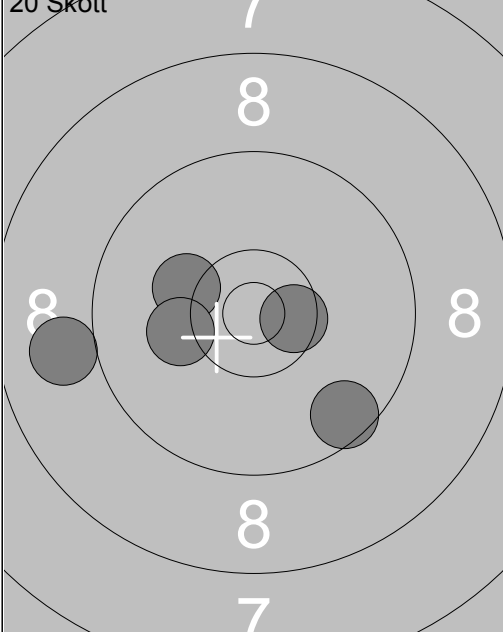
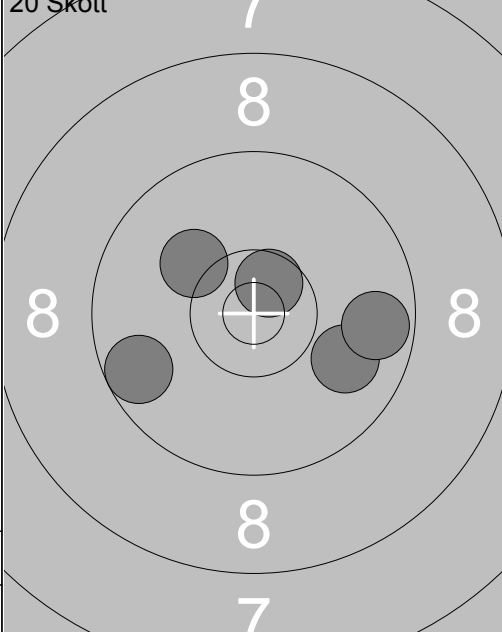
Skjuttag	Tavla	Hilde Karlsson			
1	13	Ramselefors		Sen-L	Vb
11.07.2017		Tavelträffen Korthåll 2017		Ramselefors SKF	
	1: 6.7 ↑		11: 10.5x➤		
	2: 8.9 ↑		12: 10.3x↓		
	3: 8.3 ↗				
	4: 9.9 ←				
	5: 9.6 ↓				
	6: 10.2 ←				
	7: 10.1 ↓				
	8: 10.3x↘				
	9: 10.5x➤				
	10: 10.0 ➔				
Serie	90.0	Serie	20.0		
Total	0.0	Total	0.0		
	1: 9.8 ←		6: 10.5x➤		
	2: 8.9 ↘		7: 10.0 ↓		
	3: 9.1 ↓		8: 10.1 ↓		
	4: 10.4x↘		9: 10.5x↘		
	5: 10.2 ➔		10: 9.9 ↓		
Serie	46.0	Serie	49.0		
Total	46.0	Total	95.0		
	11: 10.2 ←		16: 10.6x↗		
	12: 9.6 ↘		17: 9.9 ➤		
	13: 9.0 ←		18: 9.7 ➔		
	14: 10.2 ←		19: 9.7 ↙		
	15: 10.5x➤		20: 10.2 ↖		
Serie	48.0	Serie	47.0		
Total	143.0	Total	190.0		

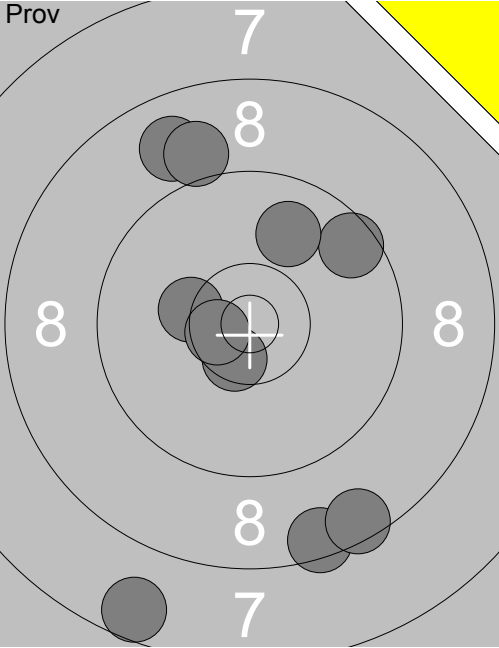
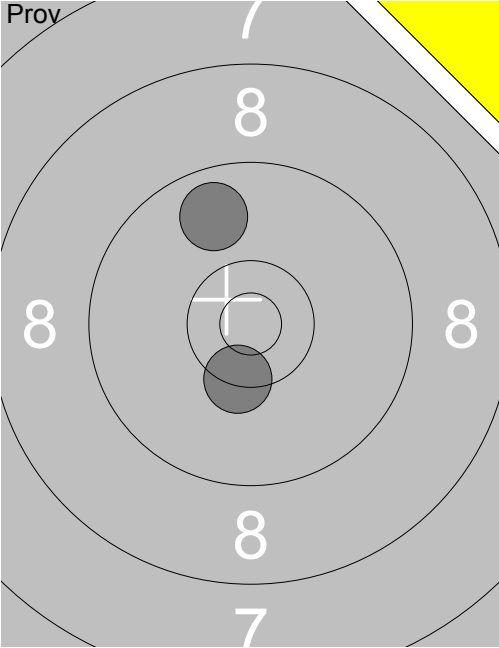
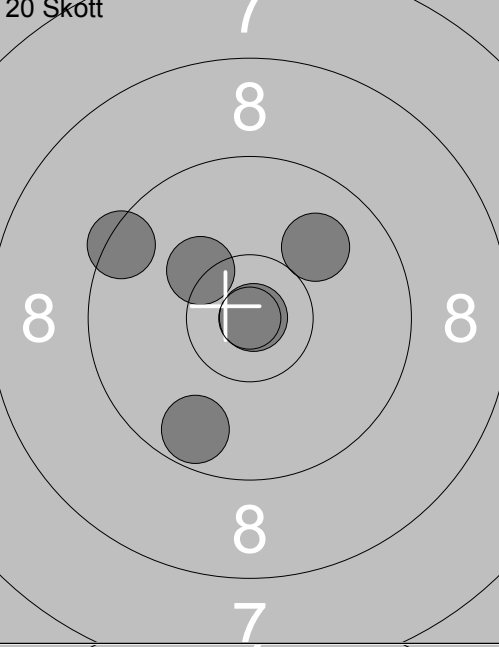
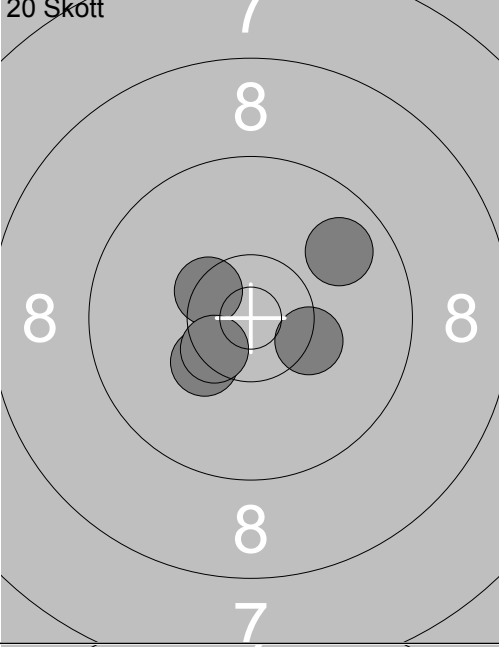
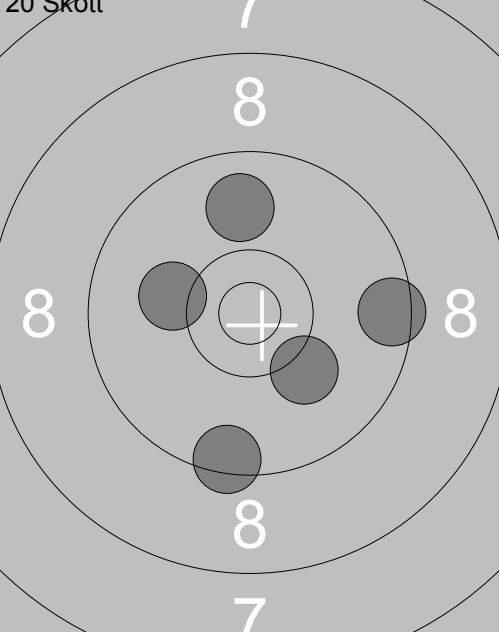
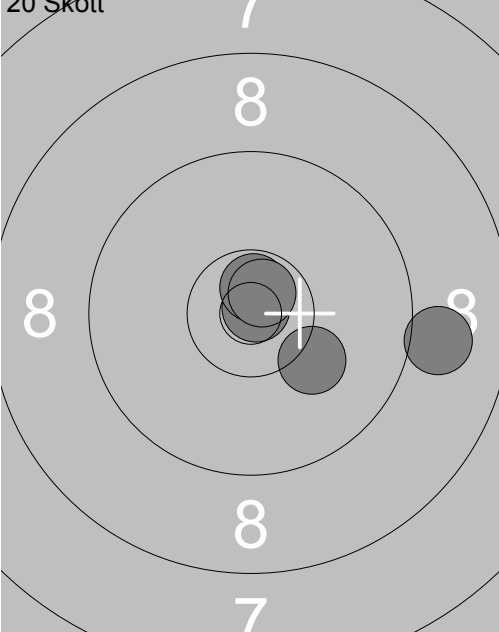
Skjutlag	Tavla	Jan Wallerström			
Vindeln	Ununge	Sen-L	St		
11.07.2017	Tavelträffen Korthåll 2017	Ramselefors SKF			
Prov 	1: 7.6 ↓ 2: 8.5 ↓ 3: 8.5 ↓ 4: 10.5x ↓ 5: 9.6 ↗ 6: 8.9 ↗ 7: 9.9 ↗ 8: 9.0 ↗ 9: 10.3x ↗ 10: 10.6x ↗	Prov 	11: 10.4x ↓ 12: 9.8 ↗		
	Serie 88.0 Total 0.0		Serie 19.0 Total 0.0		
20 Skott 	1: 10.3 ↗ 2: 10.9x ↗ 3: 9.4 ↗ 4: 10.0 ↗ 5: 9.7 ↓	20 Skott 	6: 10.4x ↗ 7: 10.3x ↗ 8: 10.3x ↗ 9: 10.5x ↗ 10: 9.8 ↗		
	Serie 48.0 Total 48.0		Serie 49.0 Total 97.0		
20 Skott 	11: 9.4 ↓ 12: 10.1 ↗ 13: 10.1 ↓ 14: 9.5 → 15: 9.9 ↗	20 Skott 	16: 10.9x ↗ 17: 10.2 ↗ 18: 10.7x ↗ 19: 10.7x ↗ 20: 9.0 →		
	Serie 47.0 Total 144.0		Serie 49.0 Total 193.0		

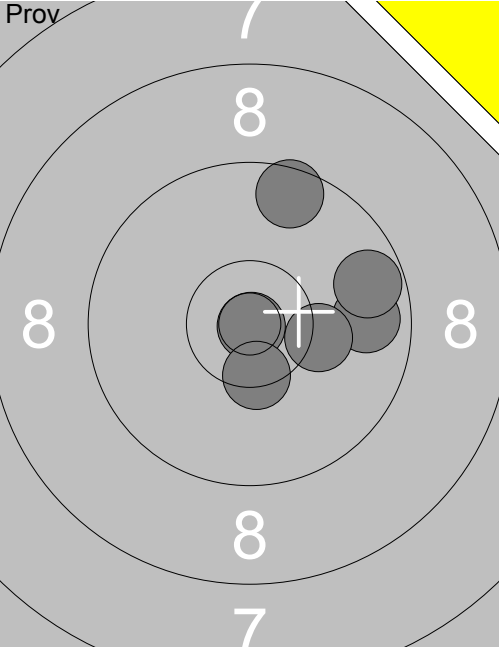
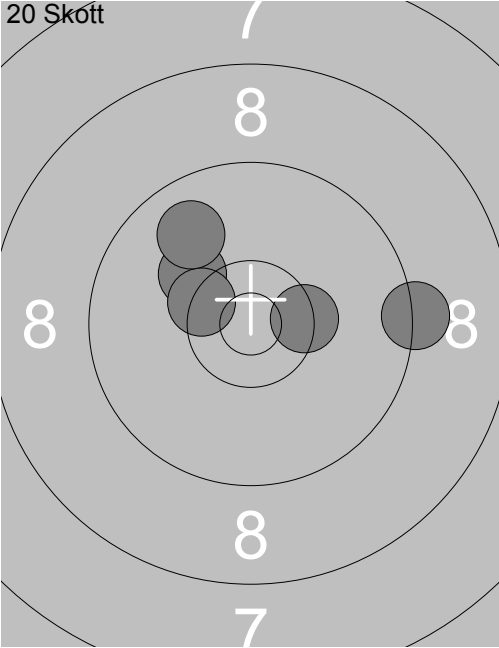
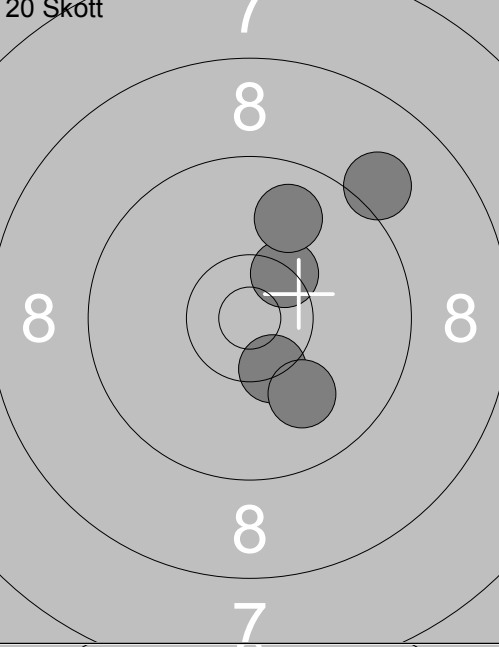
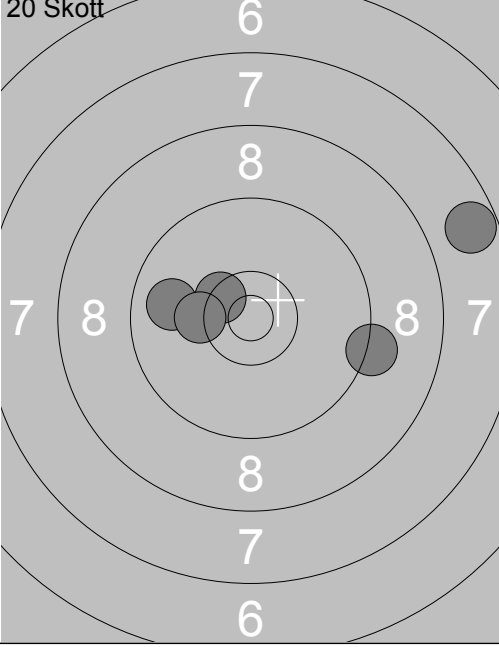
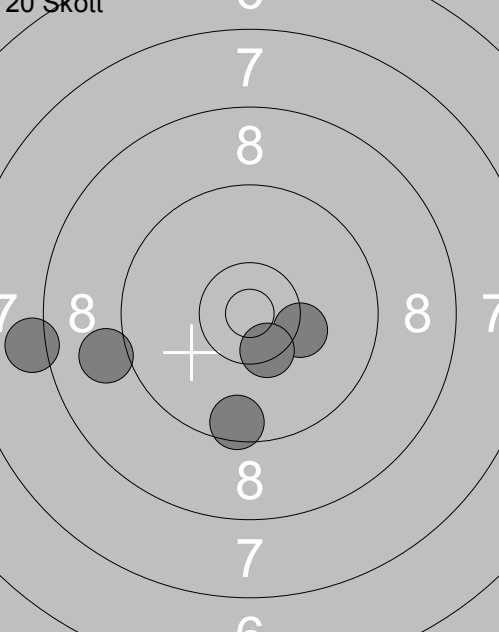
Skjutlag	Tavla	Johan Nilsson		
1	15			
Vindeln	Ramselefors	Sen-L	Vb	
11.07.2017	Tavelträffen Korthåll 2017	Ramselefors SKF		
Prov		1: 9.6 ↗ 2: 9.8 → 3: 9.7 → 4: 10.9x↓ 5: 10.2 → 6: 10.4x↓	20 Skott	 1: 10.2 ↖ 2: 10.4x↖ 3: 9.3 → 4: 10.4x→ 5: 9.9 ↖
		Serie 57.0		Serie 48.0
		Total 0.0		Total 48.0
20 Skott		6: 9.1 ↗ 7: 10.4x↗ 8: 9.9 ↗ 9: 10.4x↓ 10: 10.0 ↓	20 Skott	 11: 7.7 → 12: 9.2 → 13: 9.9 ← 14: 10.4x↖ 15: 10.2←
		Serie 48.0		Serie 45.0
		Total 96.0		Total 141.0
20 Skott		16: 10.3 → 17: 8.1 ← 18: 9.5 ↓ 19: 10.4x↓ 20: 9.0 ←		
		Serie 46.0		
		Total 187.0		

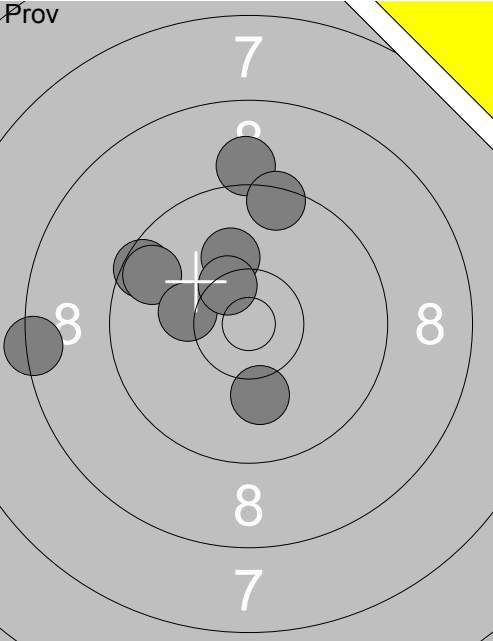
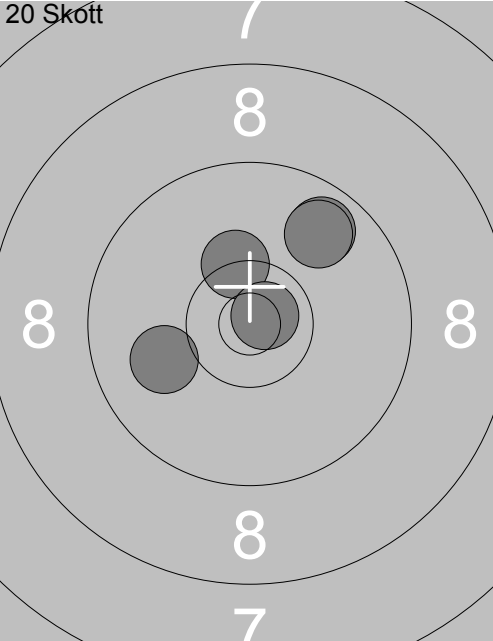
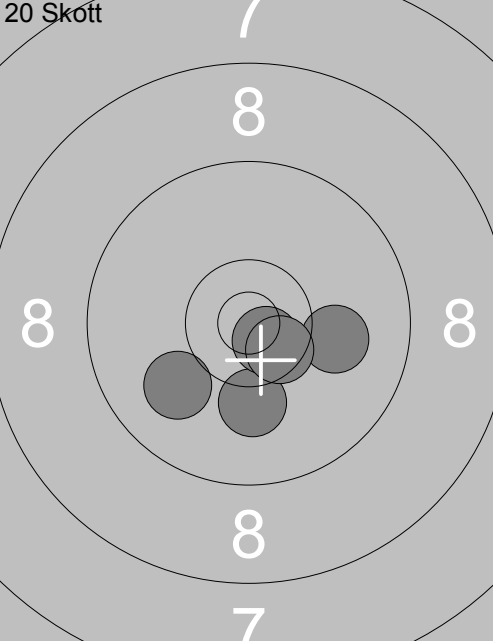
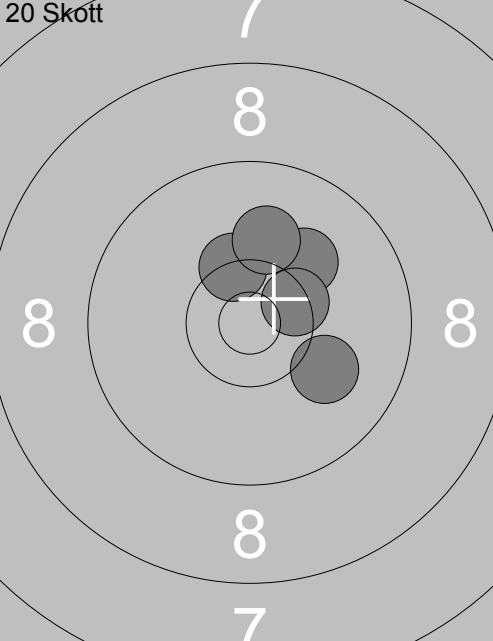
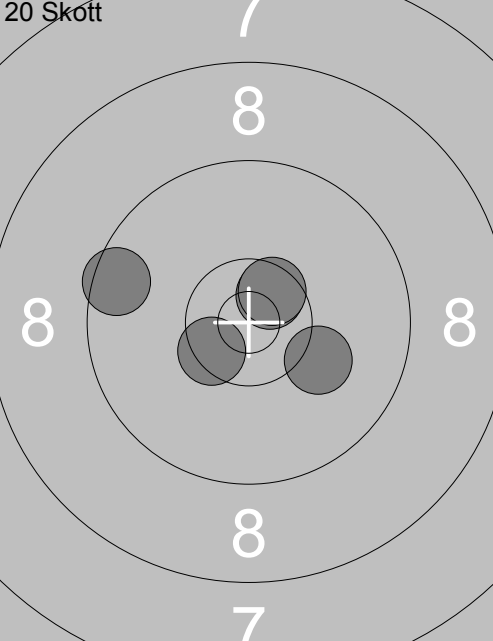
Skjutlag	Tavla	Lars Möllsten		
1	16	Vindeln	Umeå	Sen-L Vb
11.07.2017	Tavelträffen Korthåll 2017	Ramselefors SKF		
Prov		1: 8.4 ← 2: 9.1 ↑ 3: 9.5 ↑ 4: 9.5 ↙ 5: 9.7 ↙ 6: 10.1 ↑ 7: 10.2 ↙ 8: 10.1 ↓ 9: 10.4 ↗	20 Skott	 1: 10.3x ↗ 2: 9.8 ↗ 3: 9.8 ↗ 4: 10.0 ↙ 5: 10.8x ↗
		Serie 84.0		Serie 48.0
		Total 0.0		Total 48.0
20 Skott		6: 10.1 ↓ 7: 10.1 → 8: 10.0 ↙ 9: 10.7x ↘ 10: 10.5x ↘	20 Skott	 11: 10.1 ↗ 12: 10.4x ↗ 13: 10.4x ↗ 14: 10.1 ↘ 15: 10.1 ↑
		Serie 50.0		Serie 50.0
		Total 98.0		Total 148.0
20 Skott		16: 9.5 ↙ 17: 10.6x ↗ 18: 10.5x ↙ 19: 10.1 ↘ 20: 10.5x ↗		
		Serie 49.0		
		Total 197.0		

	<p>1: 10.0 ↓</p> <p>2: 9.2 ↙</p> <p>3: 8.0 ↗</p> <p>4: 10.2 ↗</p> <p>5: 9.1 ↙</p> <p>6: 10.1 ↙</p> <p>7: 10.0 ↙</p> <p>8: 9.9 ↑</p> <p>9: 10.0 ↗</p> <p>10: 9.8 ↑</p> <p>Serie 94.0</p> <p>Total 0.0</p>		<p>11: 10.1 ↗</p> <p>12: 10.5x ↙</p> <p>13: 10.0 ↘</p> <p>14: 10.0 ↓</p> <p>15: 10.0 ↗</p> <p>16: 10.5x ↗</p> <p>17: 9.2 ↘</p> <p>Serie 69.0</p> <p>Total 0.0</p>
<p>20 Skott</p>	<p>1: 10.0 ↙</p> <p>2: 10.0 ↙</p> <p>3: 9.6 →</p> <p>4: 10.6x ↓</p> <p>5: 9.5 ↓</p> <p>Serie 48.0</p> <p>Total 48.0</p>	<p>20 Skott</p>	<p>6: 10.1 ↗</p> <p>7: 10.5x ↙</p> <p>8: 9.3 →</p> <p>9: 9.4 →</p> <p>10: 9.7 ↑</p> <p>Serie 47.0</p> <p>Total 95.0</p>
<p>20 Skott</p>	<p>11: 9.8 ↗</p> <p>12: 9.7 →</p> <p>13: 9.4 ↓</p> <p>14: 9.2 ↓</p> <p>15: 10.4x ↑</p> <p>Serie 46.0</p> <p>Total 141.0</p>	<p>20 Skott</p>	<p>16: 10.1 ←</p> <p>17: 9.7 ↓</p> <p>18: 10.5x ↘</p> <p>19: 10.2 ↘</p> <p>20: 10.0 ↓</p> <p>Serie 49.0</p> <p>Total 190.0</p>

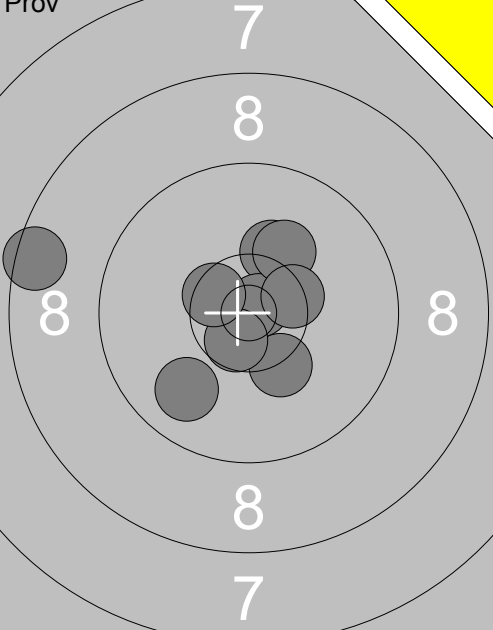
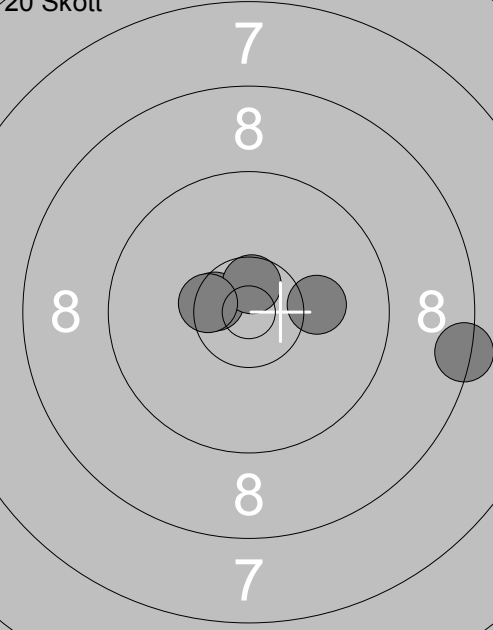
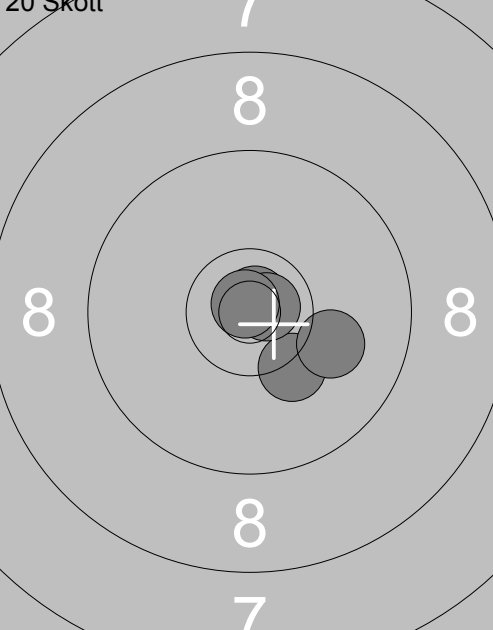
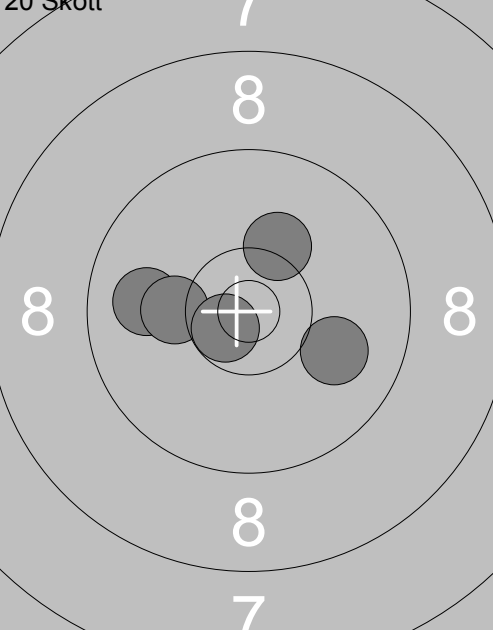
Prov 	1: 8.5 ← 2: 9.9 ↙ 3: 10.2 ↗ 4: 10.3 ↘ 5: 10.8x ↗	20 Skott 	1: 10.6x ↗ 2: 10.7x ↗ 3: 9.4 ➤ 4: 9.8 ↘ 5: 10.5x ↗
	Serie 87.0 Total 0.0		Serie 48.0 Total 48.0
20 Skott 	6: 10.5x ↗ 7: 10.1 ➔ 8: 10.6x ↗ 9: 8.4 ➤ 10: 10.5x ↗	20 Skott 	11: 10.8x ↗ 12: 10.2 ↘ 13: 10.1 ➤ 14: 10.8x ↗ 15: 10.9x ↗
	Serie 48.0 Total 96.0		Serie 50.0 Total 146.0
20 Skott 	16: 10.2 ↗ 17: 9.9 ← 18: 10.2 ← 19: 10.0 ➤ 20: 10.7x ↗		
	Serie 49.0 Total 195.0		

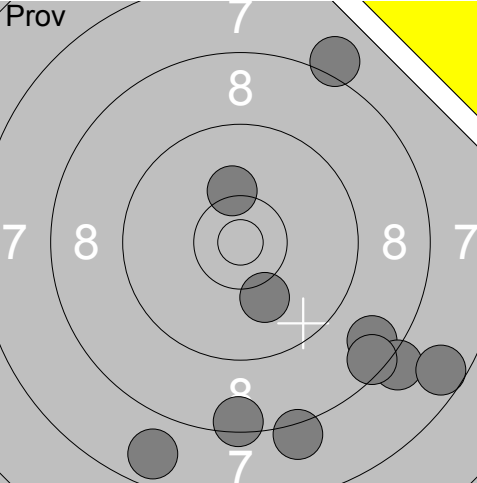
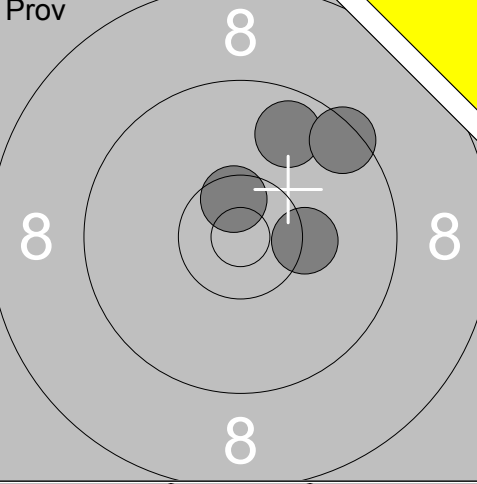
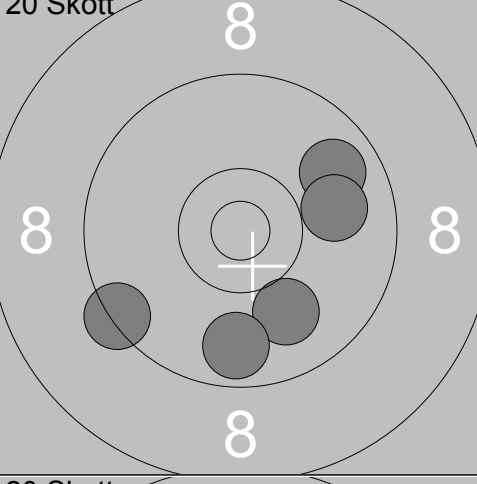
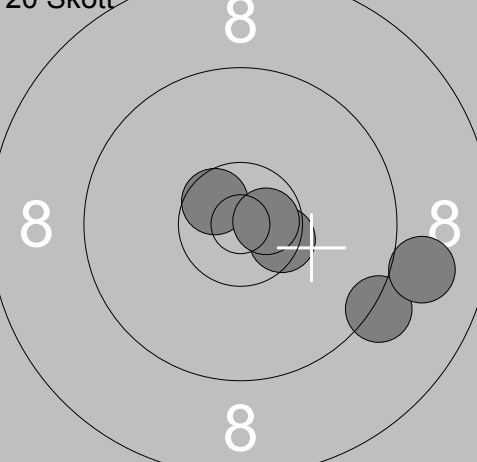
Skjutlag	Tavla	Maja Lindberg		Jun-L	Vb
1	19				
Vindeln	Ramselefors				
11.07.2017	Tavelträffen Korthåll 2017	Ramselefors SKF			
Prov		1: 10.1 ↘ 2: 7.8 ↘ 3: 8.5 ↘ 4: 8.7 ↘ 5: 8.2 ↘ 6: 8.1 ↘ 7: 8.5 ↘ 8: 7.6 ↘ 9: 10.2 ↗ 10: 8.1 ↗	Prov	11: 9.1 ↗ 12: 8.7 ↗ 13: 9.1 ↗ 14: 9.8 ↘ 15: 10.3x ↗ 16: 9.2 ↗ 17: 10.0 ↗ 18: 9.4 ↗ 19: 9.7 ↗ 20: 8.7 ↗	
		Serie 82.0		Serie 90.0	
		Total 0.0		Total 0.0	
Prov		21: 10.3 → 22: 9.8 ↗ 23: 9.5 ↗ 24: 10.5x ↗	20 Skott	1: 9.5 ↗ 2: 9.9 ← 3: 10.5x ← 4: 10.6x ↗ 5: 9.5 ↘	
		Serie 38.0		Serie 47.0	
		Total 0.0		Total 47.0	
20 Skott		6: 10.0 ↘ 7: 9.7 ↘ 8: 9.8 ↗ 9: 9.9 → 10: 9.4 ←	20 Skott	11: 10.2 ↘ 12: 10.5x ← 13: 10.4x ↗ 14: 10.4x ↗ 15: 10.4x →	
		Serie 46.0		Serie 50.0	
		Total 93.0		Total 143.0	
20 Skott		16: 10.6x ↗ 17: 9.2 ↘ 18: 10.5x ↘ 19: 10.7x → 20: 9.0 →			
		Serie 48.0			
		Total 191.0			

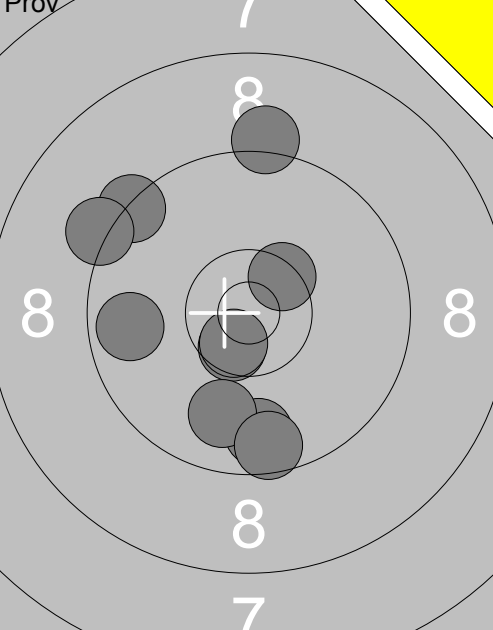
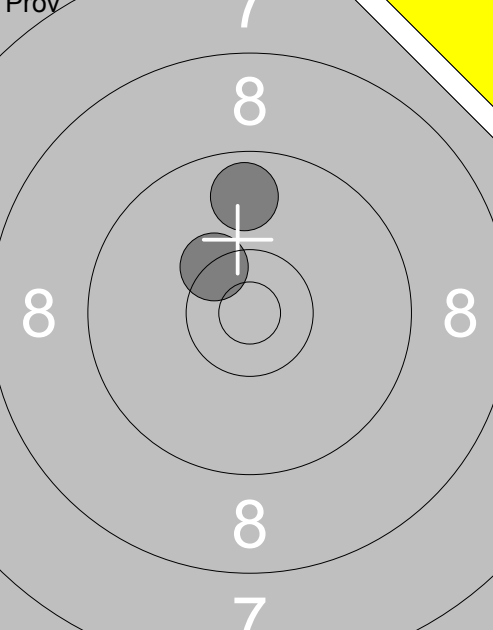
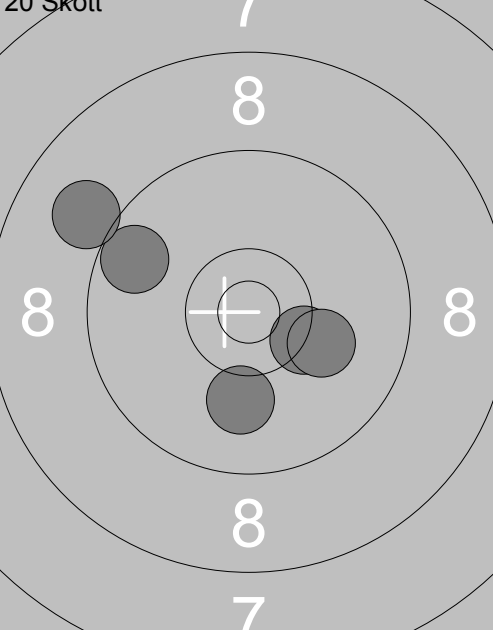
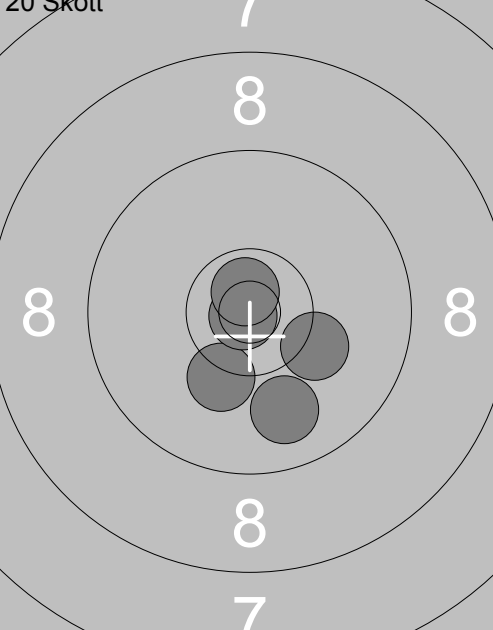
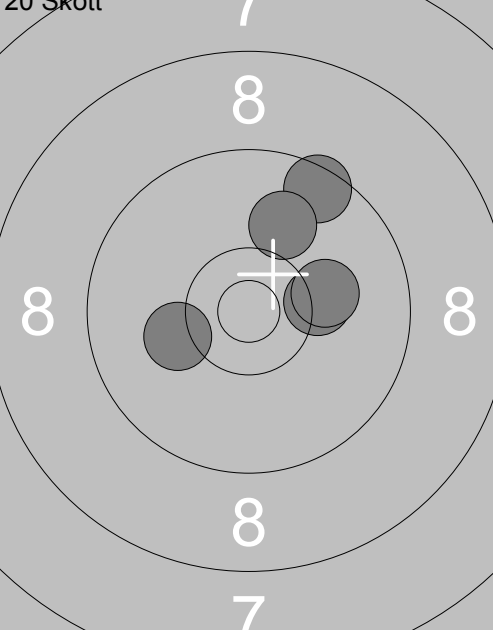
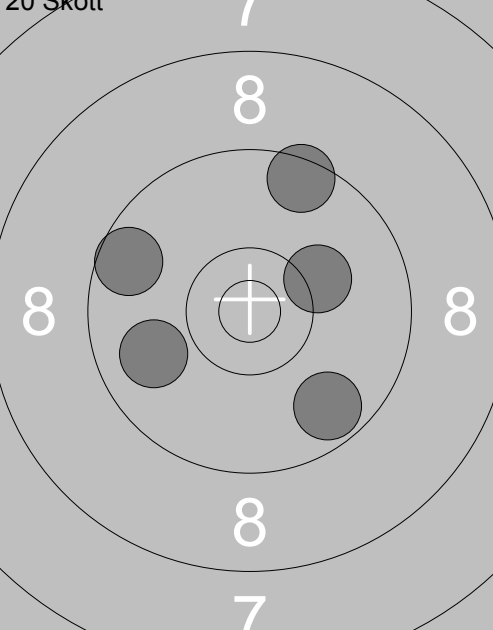
<div style="text-align: center;">Prov</div> 	<div style="text-align: center;">Prov</div> 	<div style="text-align: right;">11: 9.8 ↑</div> <div style="text-align: right;">12: 10.4 ↘</div>
<p>1: 9.4 ↖</p> <p>2: 9.2 ↖</p> <p>3: 10.6x ↘</p> <p>4: 9.7 ↓</p> <p>5: 10.6x ↘</p> <p>6: 9.2 ↑</p> <p>7: 9.9 ↓</p> <p>8: 9.7 ←</p> <p>9: 10.5x ↗</p> <p>10: 9.6 ↓</p>	<p>Serie 93.0</p> <p>Total 0.0</p>	<p>Serie 19.0</p> <p>Total 0.0</p>
<div style="text-align: center;">20 Skott</div> 	<div style="text-align: center;">20 Skott</div> 	<div style="text-align: right;">6: 9.9 ↓</div> <div style="text-align: right;">7: 10.2 ↘</div> <div style="text-align: right;">8: 10.9x ↘</div> <div style="text-align: right;">9: 10.7x ↗</div> <div style="text-align: right;">10: 10.2 ↘</div>
<p>1: 9.7 ↖</p> <p>2: 9.0 ↖</p> <p>3: 10.3x ↘</p> <p>4: 10.1 ↓</p> <p>5: 10.1 →</p>	<p>Serie 48.0</p> <p>Total 48.0</p>	<p>Serie 49.0</p> <p>Total 97.0</p>
<div style="text-align: center;">20 Skott</div> 	<div style="text-align: center;">20 Skott</div> 	<div style="text-align: right;">16: 9.9 ↖</div> <div style="text-align: right;">17: 9.7 ↘</div> <div style="text-align: right;">18: 10.2 →</div> <div style="text-align: right;">19: 9.6 ↖</div> <div style="text-align: right;">20: 9.5 ↑</div>
<p>11: 10.2 →</p> <p>12: 10.2 ↖</p> <p>13: 10.2 →</p> <p>14: 9.5 ↗</p> <p>15: 10.0 ↗</p>	<p>Serie 49.0</p> <p>Total 146.0</p>	<p>Serie 46.0</p> <p>Total 192.0</p>

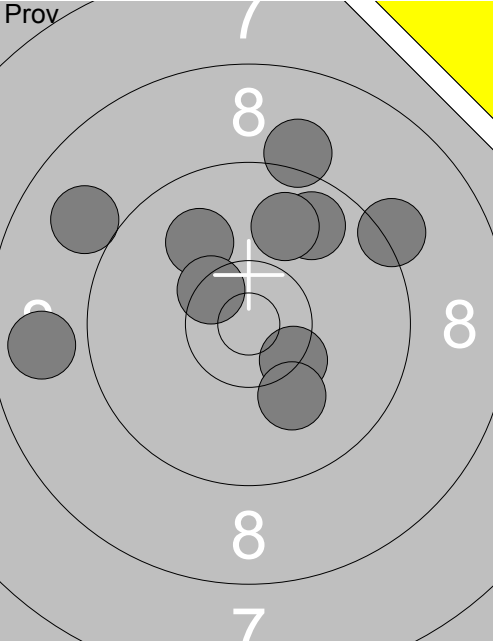
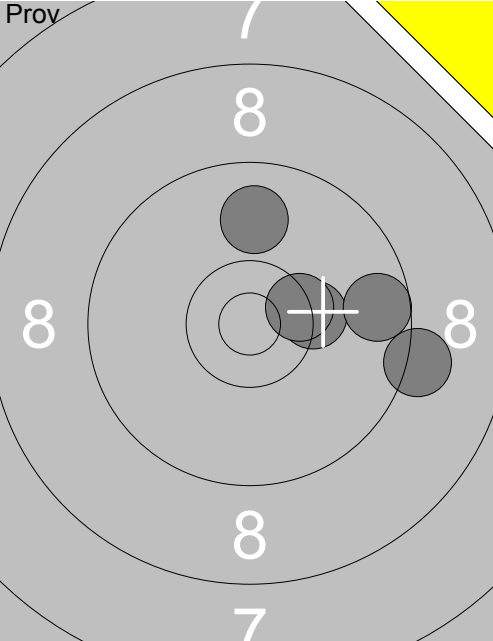
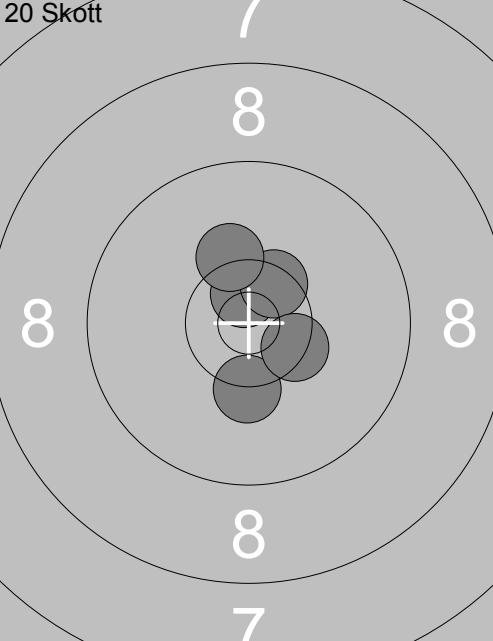
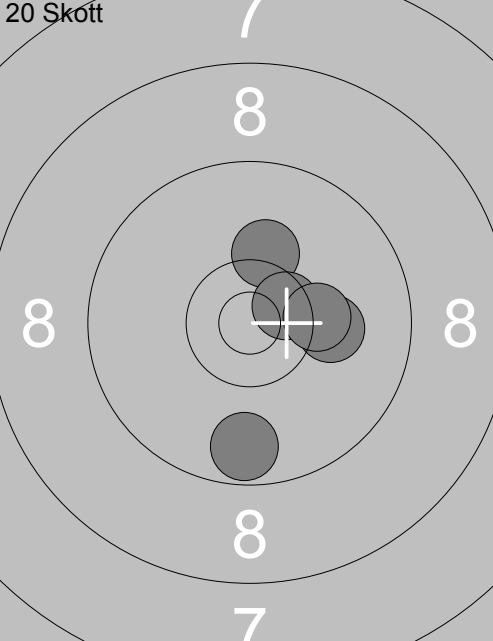
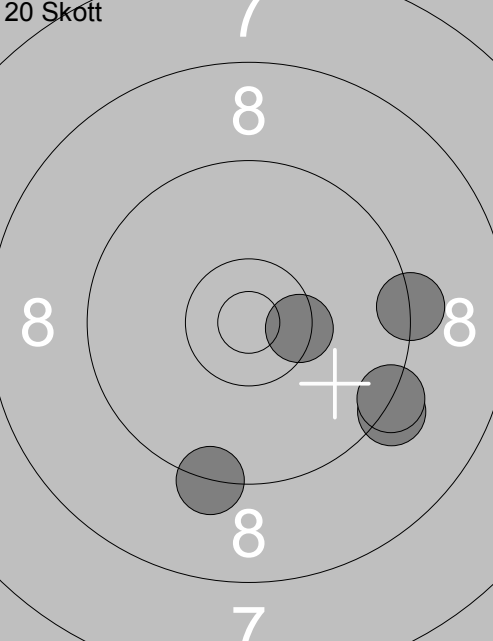
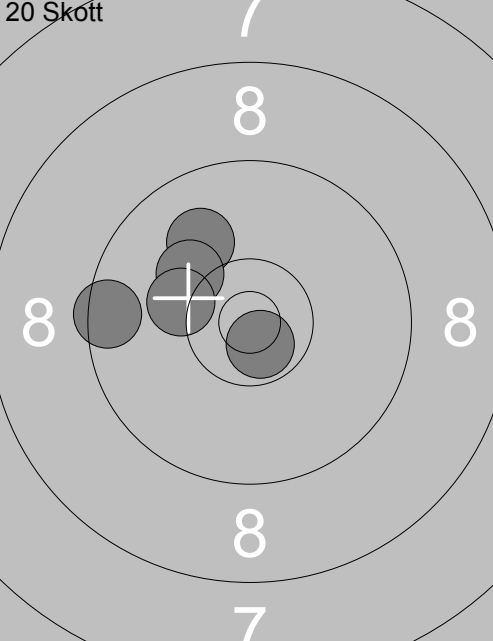
Skjutlag	Tavla	Marlene Forsell Forsman			
1	21	Ramselefors		Sen-L	Vb
11.07.2017		Tavelträffen Korthåll 2017		Ramselefors SKF	
Prov 	1: 8.8 ←	Prov 	11: 9.9 ↑		
	2: 9.0 ↖		12: 10.3x➤		
	3: 9.1 ↑		13: 10.4x➤		
	4: 9.8 ↗		14: 9.6 →		
	5: 10.4x➤		15: 9.2 ➤		
	6: 10.0 ↖				
	7: 10.1 ↓				
	8: 9.9 ↑				
	9: 10.4x➤				
	10: 9.2 ↗				
	Serie 93.0		Serie 47.0		
	Total 0.0		Total 0.0		
20 Skott 	1: 10.6x↑	20 Skott 	6: 10.2 ↑		
	2: 10.3 ↓		7: 10.5x➤		
	3: 10.5x↗		8: 10.1 →		
	4: 10.3 ↑		9: 10.3 →		
	5: 10.4x➤		10: 9.7 ↓		
	Serie 50.0		Serie 49.0		
	Total 50.0		Total 99.0		
20 Skott 	11: 10.4x➤	20 Skott 	16: 10.0 ↖		
	12: 9.2 ➤		17: 10.7x↓		
	13: 9.3 →		18: 10.2 ↖		
	14: 9.3 ↓		19: 9.5 ←		
	15: 9.3 ➤		20: 10.2↖		
	Serie 46.0		Serie 49.0		
	Total 145.0		Total 194.0		

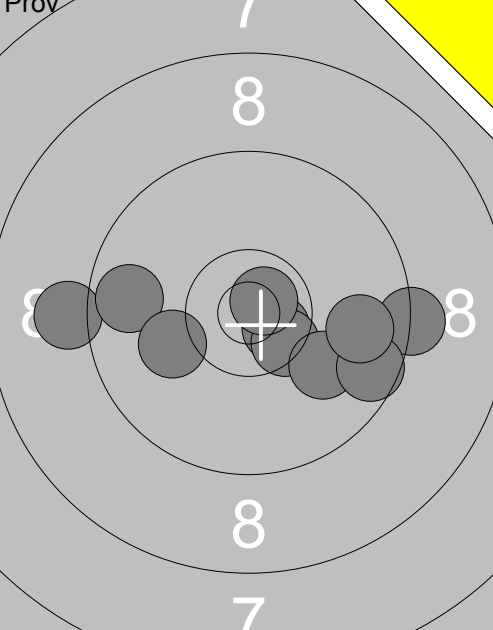
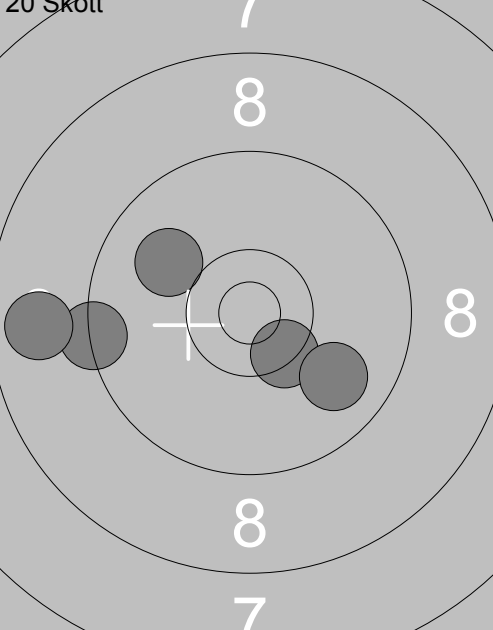
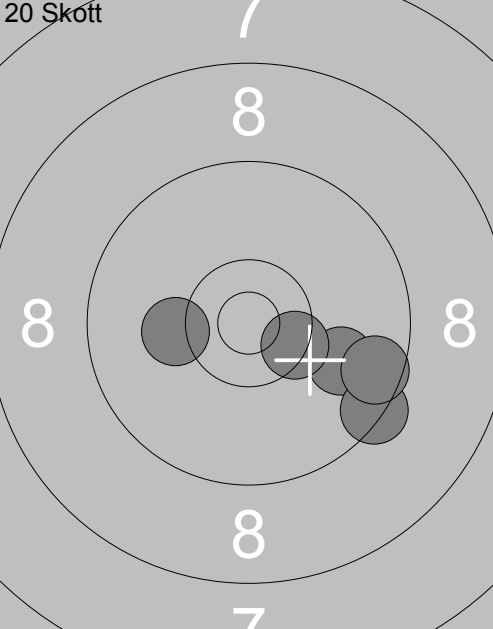
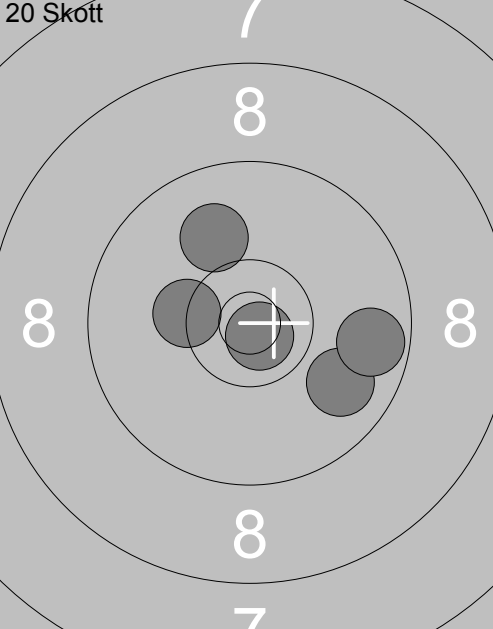
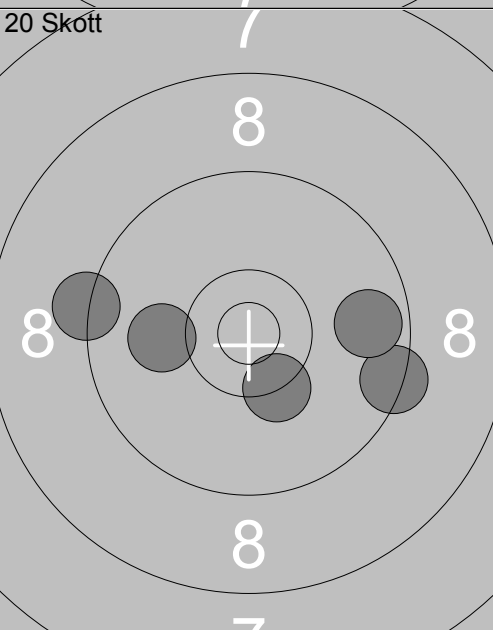
 <p>Prov</p>	<p>20 Skott</p> <p>1: 9.1 ←</p> <p>2: 10.6x ↘</p> <p>3: 10.5x ↘</p> <p>4: 9.3 →</p> <p>5: 9.7 ←</p> <p>6: 10.1 ←</p> <p>7: 10.8x ↗</p> <p>8: 10.0 ↘</p> <p>9: 9.6 ↘</p> <p>10: 9.8 →</p> <p>Serie 95.0</p> <p>Total 0.0</p>	 <p>20 Skott</p> <p>1: 9.3 ←</p> <p>2: 10.4x ↘</p> <p>3: 10.0 ↗</p> <p>4: 9.9 ↘</p> <p>5: 8.8 ←</p> <p>Serie 46.0</p> <p>Total 46.0</p>
 <p>20 Skott</p>	<p>6: 9.9 ↘</p> <p>7: 10.4x ↘</p> <p>8: 9.4 ↘</p> <p>9: 10.2 ←</p> <p>10: 9.6 →</p> <p>Serie 47.0</p> <p>Total 93.0</p>	 <p>20 Skott</p> <p>11: 10.0 ↗</p> <p>12: 9.9 ↘</p> <p>13: 10.8x ↘</p> <p>14: 9.7 →</p> <p>15: 10.3x ↗</p> <p>Serie 48.0</p> <p>Total 141.0</p>
 <p>20 Skott</p>	<p>16: 10.3x ↘</p> <p>17: 10.1 ←</p> <p>18: 9.4 →</p> <p>19: 9.3 ←</p> <p>20: 9.7 →</p> <p>Serie 47.0</p> <p>Total 188.0</p>	

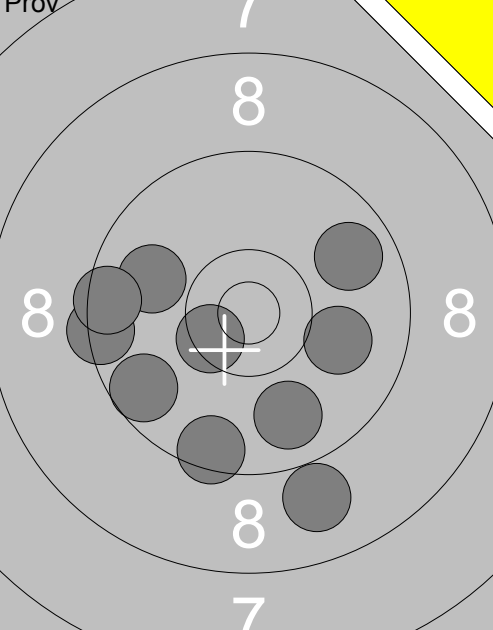
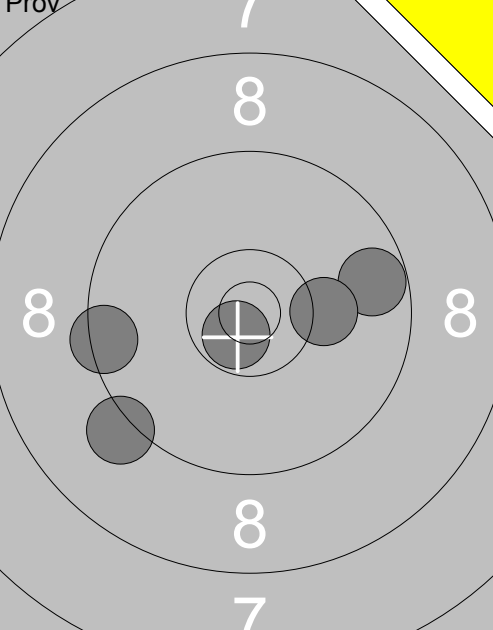
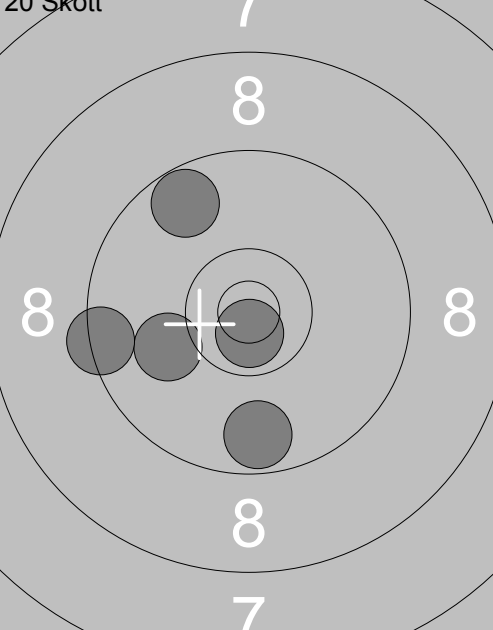
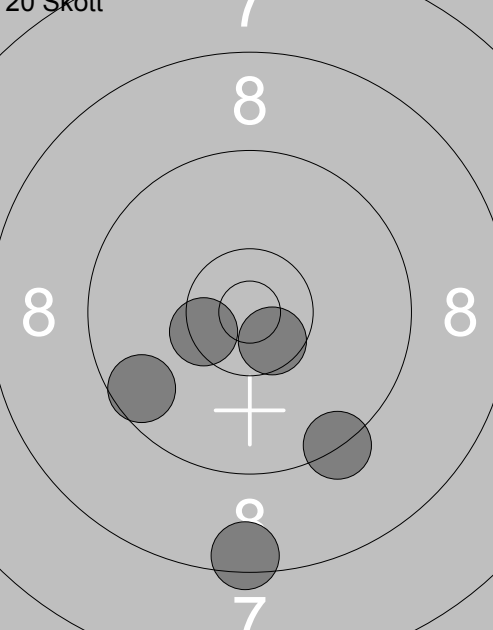
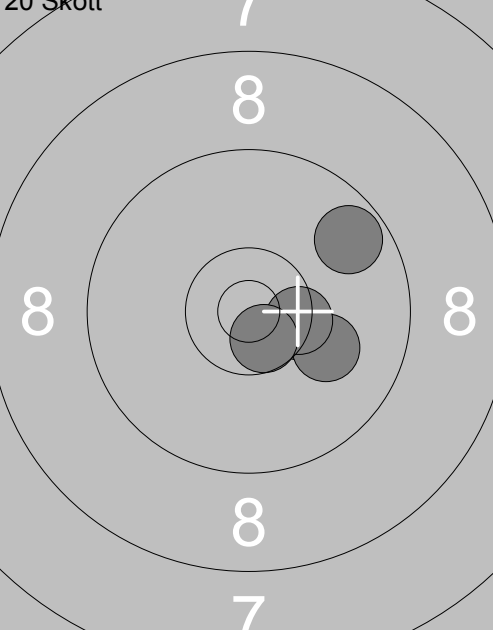
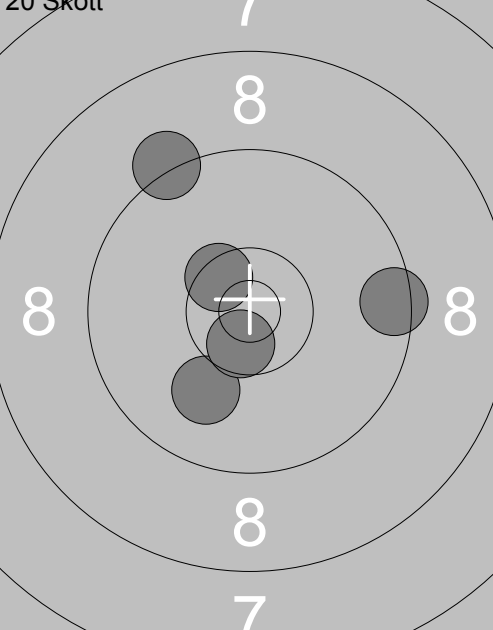
Prov 	1: 9.9 ← 2: 8.9 ↓ 3: 10.0 → 4: 9.8 ↓ 5: 9.8 ↗ 6: 10.5x ↘ 7: 9.5 ↓ 8: 9.4 ← 9: 9.6 ↙ 10: 9.5 ← Serie 91.0 Total 0.0	Prov 	11: 9.7 → 12: 10.2 → 13: 10.7x ↘ 14: 9.4 ← 15: 9.2 ↙ Serie 47.0 Total 0.0
20 Skott 	1: 10.1 ← 2: 9.4 ← 3: 9.7 ↓ 4: 10.7x ↘ 5: 9.7 ↗ Serie 47.0 Total 47.0	20 Skott 	6: 10.6x ↘ 7: 10.4x ↘ 8: 9.6 ↙ 9: 9.3 ↓ 10: 8.5 ↓ Serie 46.0 Total 93.0
20 Skott 	11: 10.4x → 12: 10.1 → 13: 10.4x → 14: 10.6x ↘ 15: 9.7 ↗ Serie 49.0 Total 142.0	20 Skott 	16: 10.0 ↓ 17: 10.5x ↘ 18: 9.5 → 19: 9.2 ↗ 20: 10.6x ↘ Serie 48.0 Total 190.0

<div style="font-size: 0.8em; margin-bottom: 5px;">Prov</div> 	<div style="font-size: 0.8em; margin-bottom: 5px;">20 Skott</div> 	<div style="font-size: 0.8em; margin-bottom: 5px;">1: 9.6 ↖</div> <div style="font-size: 0.8em; margin-bottom: 5px;">2: 10.2 ↑</div> <div style="font-size: 0.8em; margin-bottom: 5px;">3: 10.1 ↗</div> <div style="font-size: 0.8em; margin-bottom: 5px;">4: 9.9 ↑</div> <div style="font-size: 0.8em; margin-bottom: 5px;">5: 9.7 ←</div> <div style="font-size: 0.8em; margin-bottom: 5px;">6: 10.5x↗</div> <div style="font-size: 0.8em; margin-bottom: 5px;">7: 10.6x↘</div> <div style="font-size: 0.8em; margin-bottom: 5px;">8: 9.7 ↓</div> <table border="1" style="width:100%; border-collapse: collapse; margin-top: 5px;"> <tr><td style="font-size: 0.8em;">Serie</td><td style="font-size: 0.8em;">76.0</td></tr> <tr><td style="font-size: 0.8em;">Total</td><td style="font-size: 0.8em;">0.0</td></tr> </table>	Serie	76.0	Total	0.0
Serie	76.0					
Total	0.0					
<div style="font-size: 0.8em; margin-bottom: 5px;">20 Skott</div> 	<div style="font-size: 0.8em; margin-bottom: 5px;">20 Skott</div> 	<div style="font-size: 0.8em; margin-bottom: 5px;">1: 10.1 ↘</div> <div style="font-size: 0.8em; margin-bottom: 5px;">2: 10.4x→</div> <div style="font-size: 0.8em; margin-bottom: 5px;">3: 10.1 ←</div> <div style="font-size: 0.8em; margin-bottom: 5px;">4: 10.5x↘</div> <div style="font-size: 0.8em; margin-bottom: 5px;">5: 10.0 ←</div> <div style="font-size: 0.8em; margin-bottom: 5px;">6: 10.0 ←</div> <div style="font-size: 0.8em; margin-bottom: 5px;">7: 10.7x←</div> <div style="font-size: 0.8em; margin-bottom: 5px;">8: 9.9 ←</div> <div style="font-size: 0.8em; margin-bottom: 5px;">9: 10.2 ↘</div> <div style="font-size: 0.8em; margin-bottom: 5px;">10: 10.2 ↘</div> <div style="font-size: 0.8em; margin-bottom: 5px;">11: 10.2 ←</div> <div style="font-size: 0.8em; margin-bottom: 5px;">12: 10.4x↘</div> <div style="font-size: 0.8em; margin-bottom: 5px;">13: 9.2 ↘</div> <div style="font-size: 0.8em; margin-bottom: 5px;">14: 10.0 ←</div> <div style="font-size: 0.8em; margin-bottom: 5px;">15: 9.6 →</div> <table border="1" style="width:100%; border-collapse: collapse; margin-top: 5px;"> <tr><td style="font-size: 0.8em;">Serie</td><td style="font-size: 0.8em;">49.0</td></tr> <tr><td style="font-size: 0.8em;">Total</td><td style="font-size: 0.8em;">99.0</td></tr> </table>	Serie	49.0	Total	99.0
Serie	49.0					
Total	99.0					
<div style="font-size: 0.8em; margin-bottom: 5px;">20 Skott</div> 	<div style="font-size: 0.8em; margin-bottom: 5px;">16: 8.6 ↓</div> <div style="font-size: 0.8em; margin-bottom: 5px;">17: 10.6x→</div> <div style="font-size: 0.8em; margin-bottom: 5px;">18: 10.4x↘</div> <div style="font-size: 0.8em; margin-bottom: 5px;">19: 9.8 →</div> <div style="font-size: 0.8em; margin-bottom: 5px;">20: 9.4 ←</div> <table border="1" style="width:100%; border-collapse: collapse; margin-top: 5px;"> <tr><td style="font-size: 0.8em;">Serie</td><td style="font-size: 0.8em;">46.0</td></tr> <tr><td style="font-size: 0.8em;">Total</td><td style="font-size: 0.8em;">193.0</td></tr> </table>		Serie	46.0	Total	193.0
Serie	46.0					
Total	193.0					

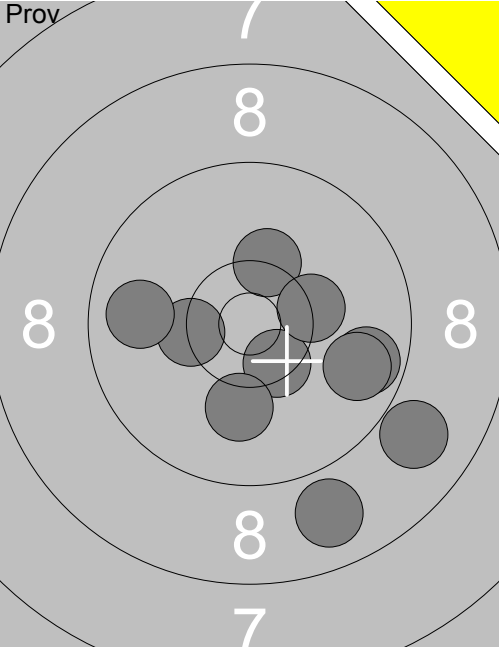
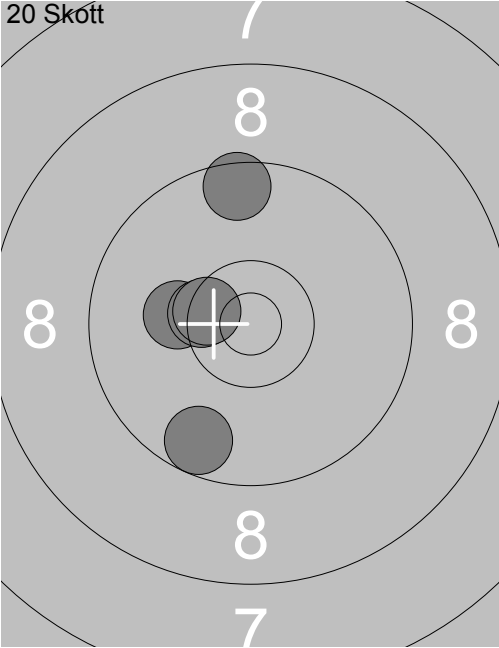
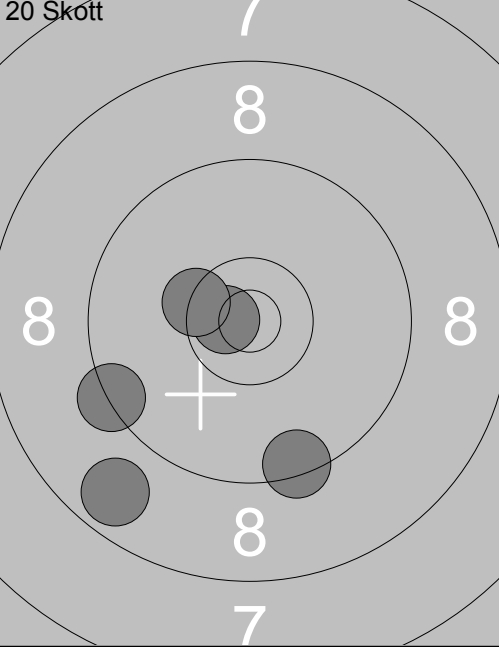
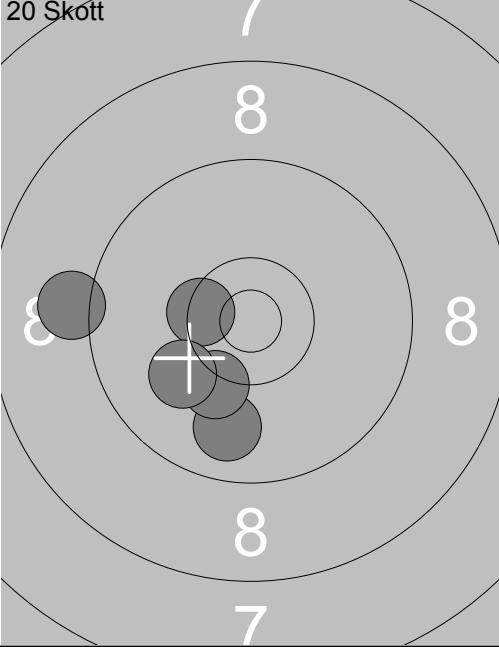
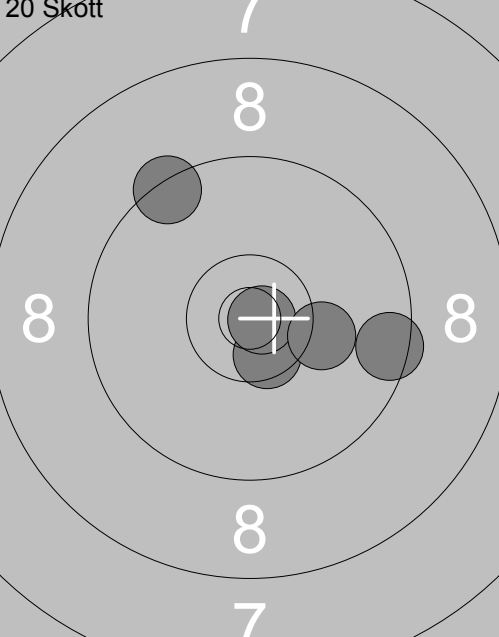
Skjutlag	Tavla	Stefan Thorin			
2	1	Vindeln	Umeå	Sen-L	Vb
11.07.2017		Tavelträffen Korthåll 2017	Ramselefors SKF		
Prov		1: 9.7 → 2: 8.9 ↘ 3: 9.8 → 4: 10.3x↗ 5: 10.3x↖ 6: 10.5x↘ 7: 10.1 ↓ 8: 10.3x→ 9: 8.9 ↓ 10: 9.8 ←	20 Skott		1: 9.6 ↓ 2: 9.5 ↑ 3: 10.2← 4: 10.4x↖ 5: 10.5x↖
		Serie 93.0		Serie 48.0	
		Total 0.0		Total 48.0	
20 Skott		6: 9.4 ↓ 7: 8.7 ↓ 8: 10.7x↖ 9: 9.3 ← 10: 10.4x↖	20 Skott		11: 9.8 ↓ 12: 10.4x↖ 13: 10.2 ↓ 14: 9.1 ← 15: 10.1 ↙
		Serie 46.0		Serie 48.0	
		Total 94.0		Total 142.0	
20 Skott		16: 10.5x↘ 17: 10.8x→ 18: 9.4 ↗ 19: 9.5 → 20: 10.2→			
		Serie 48.0			
		Total 190.0			

Skjuttag	Tavla	Urban Johansson			
2	2	F 21		Sen-L	No
11.07.2017		Tavelträffen Korthåll 2017		Ramselefors SKF	
	1: 5.7 ↗		11: 9.9 ↓		
	2: 9.1 ←		12: 10.0 ↘		
	3: 10.2 ←		13: 8.4 ↑		
	4: 10.2 ↙		14: 8.3 ↗		
	5: 10.3x ↘				
	6: 9.4 ←				
	7: 10.2 ←				
	8: 9.8 ←				
	9: 10.1 ↘				
	10: 8.6 →				
	Serie 90.0		Serie 35.0		
	Total 0.0		Total 0.0		
	1: 9.8 ↑		6: 10.6x ↗		
	2: 10.5x ↘		7: 10.1 ↗		
	3: 10.2 ←		8: 8.9 ↗		
	4: 8.0 ↓		9: 10.2 ↙		
	5: 10.2 →		10: 10.8x ↘		
	Serie 47.0		Serie 48.0		
	Total 47.0		Total 95.0		
	11: 10.8x ↘		16: 10.3 →		
	12: 10.8x ↙		17: 10.3x ↘		
	13: 10.6x ↘		18: 10.1 ↓		
	14: 9.7 ↙		19: 10.1 →		
	15: 10.3 ↗		20: 9.2 ↓		
	Serie 49.0		Serie 49.0		
	Total 144.0		Total 193.0		

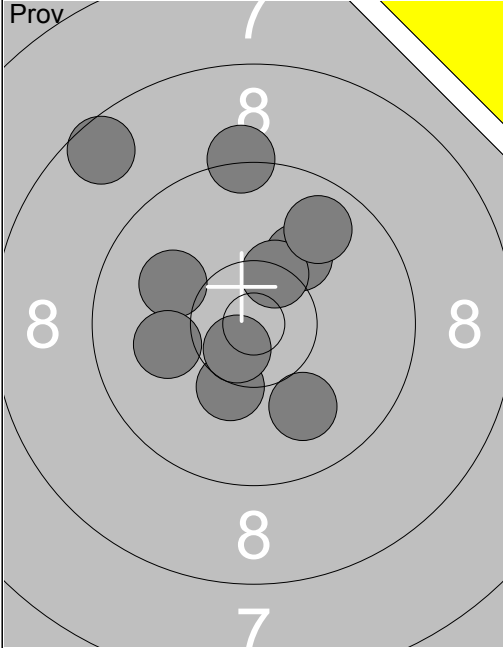
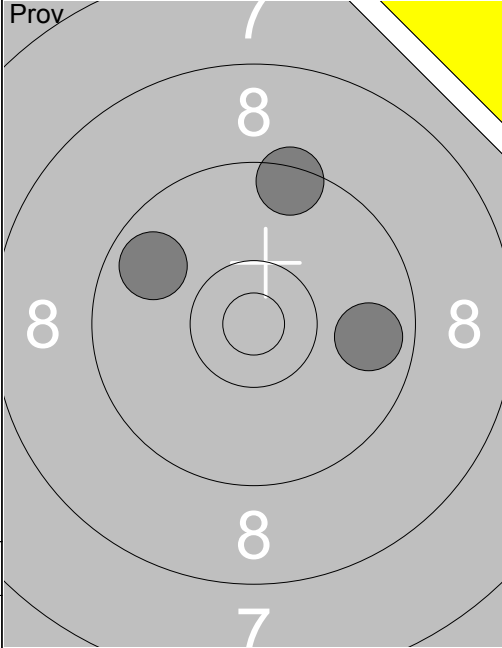
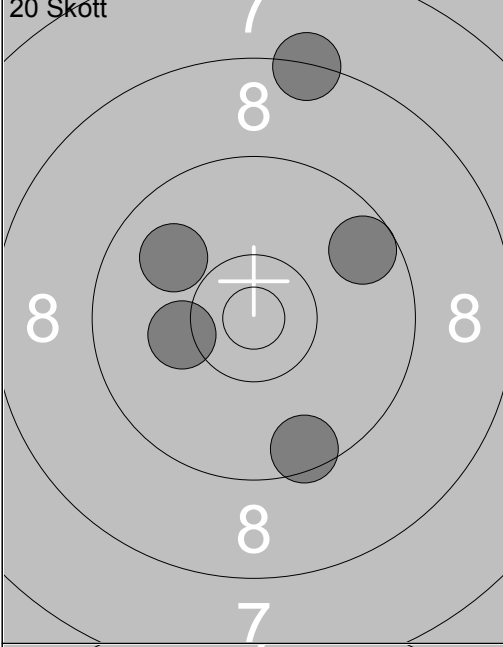
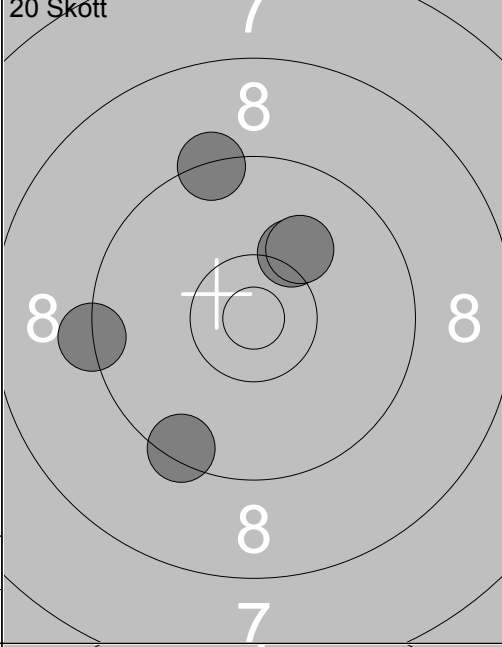
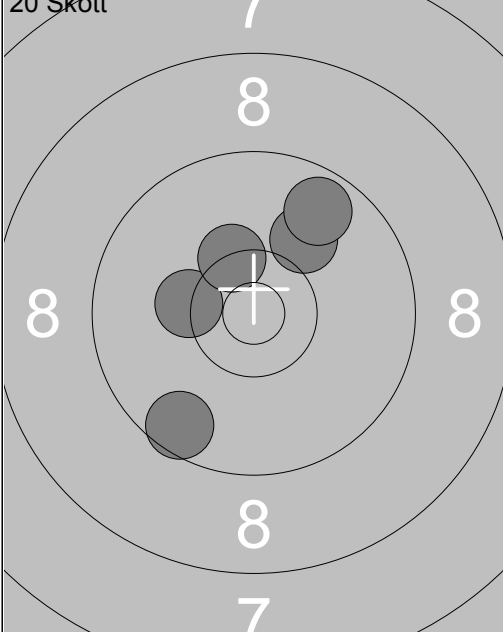
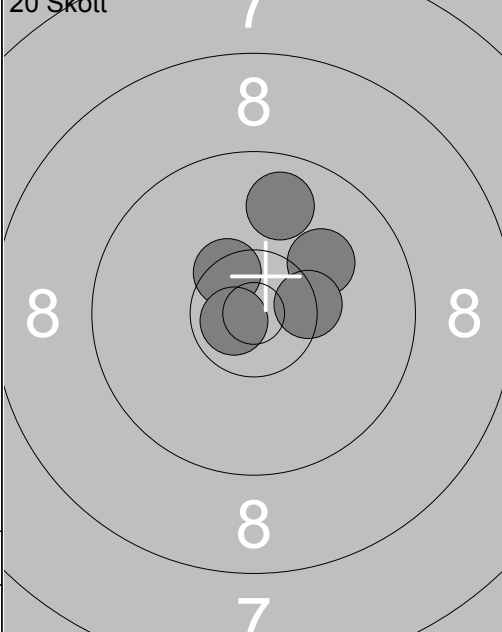
Skjuttag	Tavla	William Grydén			
2	3	Vaksala	Jun-L	Up	
11.07.2017	Tavelträffen Korthåll 2017	Ramselefors SKF			
	1: 10.0 ↙		11: 9.4 ↑		
	2: 10.3 ↓		12: 9.8 ↙		
	3: 10.0 ↓		13: 9.8 →		
	4: 10.1 ←				
	5: 8.6 ↘				
	6: 10.1 ↗				
	7: 10.4x ↗				
	8: 10.6x ↓				
	9: 9.3 ↑				
	10: 9.8 ↗				
	Serie 96.0		Serie 27.0		
	Total 0.0		Total 0.0		
	1: 8.3 ↑		6: 10.2 ↗		
	2: 9.6 ↗		7: 9.3 ↑		
	3: 9.5 ↓		8: 10.1 ↗		
	4: 10.2 ←		9: 9.3 ←		
	5: 9.9 ↘		10: 9.4 ↓		
	Serie 45.0		Serie 47.0		
	Total 45.0		Total 92.0		
	11: 10.3 ←		16: 10.5x ↘		
	12: 10.0 ↗		17: 10.1 ↗		
	13: 9.7 ↗		18: 9.8 ↑		
	14: 9.6 ↓		19: 10.7x ↘		
	15: 10.3x ↘		20: 10.4x →		
	Serie 48.0		Serie 49.0		
	Total 140.0		Total 189.0		

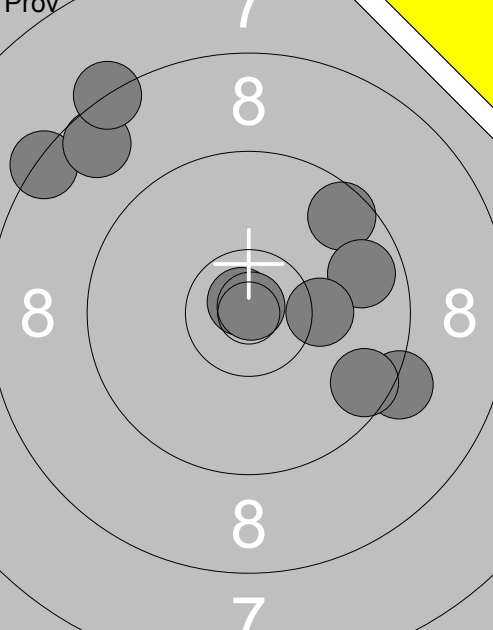
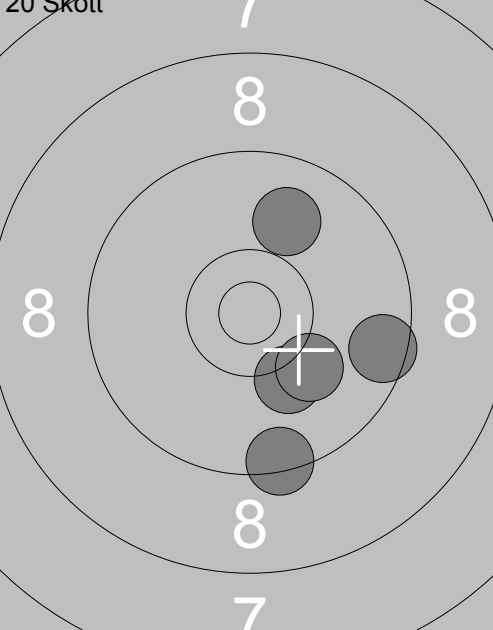
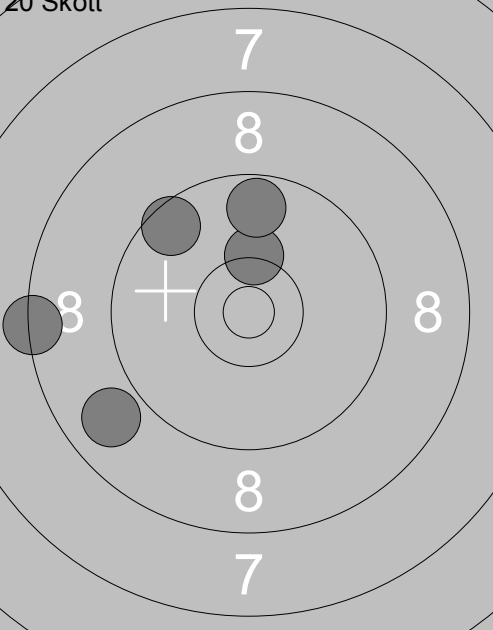
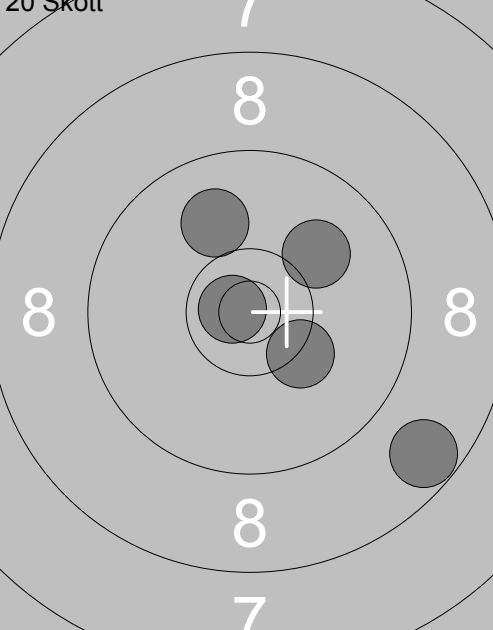
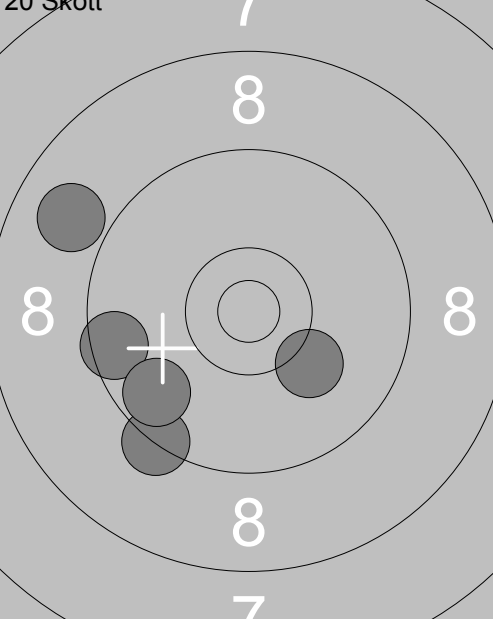
	<p>20 Skott</p> <p>1: 8.4 ↖ 2: 8.6 ↖ 3: 8.3 ↖ 4: 9.6 ↗ 5: 9.7 → 6: 10.8x ↖ 7: 10.9x ↗ 8: 10.2 → 9: 9.3 ↘ 10: 9.6 ↘</p> <p>Serie 90.0 Total 0.0</p>		<p>20 Skott</p> <p>1: 10.2 ↘ 2: 9.4 ↘ 3: 10.1 ↘ 4: 9.9 ↗ 5: 9.5 →</p> <p>Serie 47.0 Total 47.0</p>
	<p>20 Skott</p> <p>6: 10.3 ↑ 7: 8.9 ↖ 8: 9.7 ↑ 9: 9.6 ↖ 10: 8.4 ←</p> <p>Serie 44.0 Total 91.0</p>		<p>20 Skott</p> <p>11: 10.0 ↑ 12: 10.8x ↖ 13: 10.1 ↗ 14: 10.3 ↘ 15: 8.7 ↘</p> <p>Serie 48.0 Total 139.0</p>
	<p>20 Skott</p> <p>16: 9.5 ← 17: 9.3 ↘ 18: 10.1 ↘ 19: 8.9 ↖ 20: 9.7 ↘</p> <p>Serie 45.0 Total 184.0</p>		

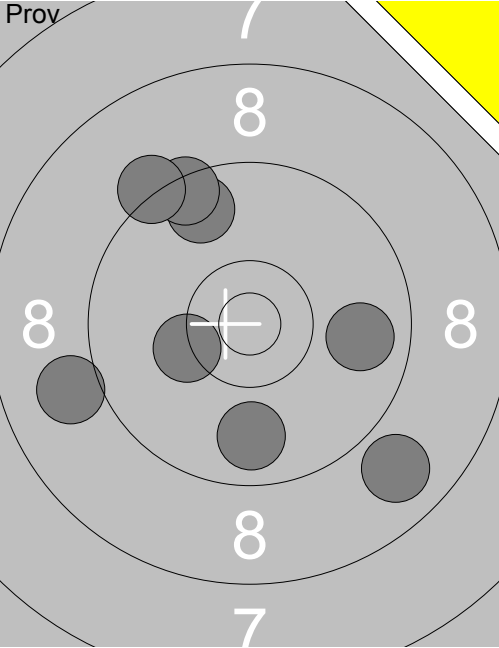
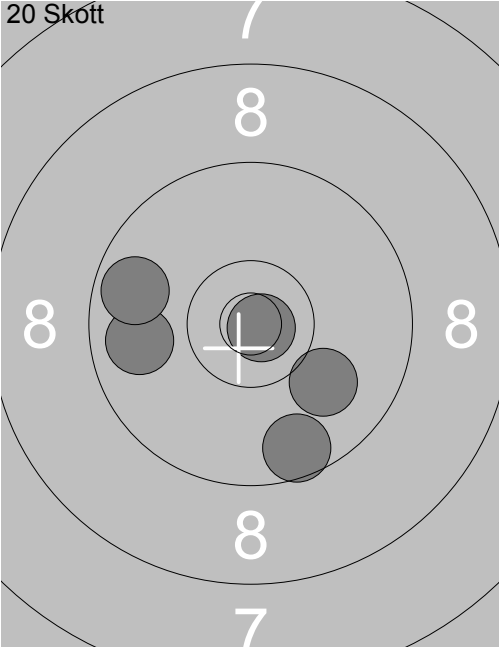
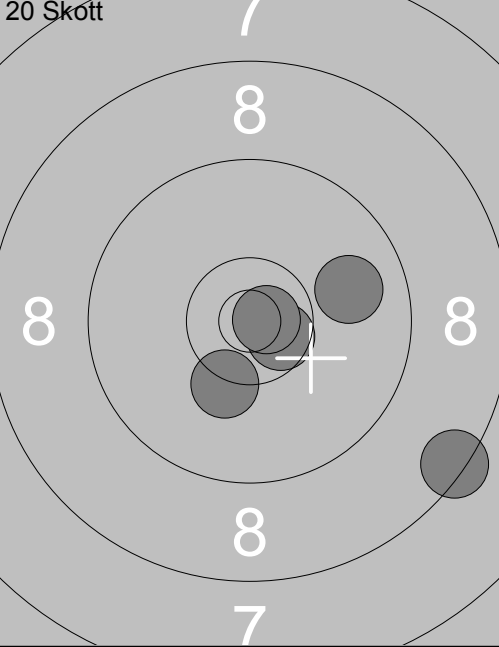
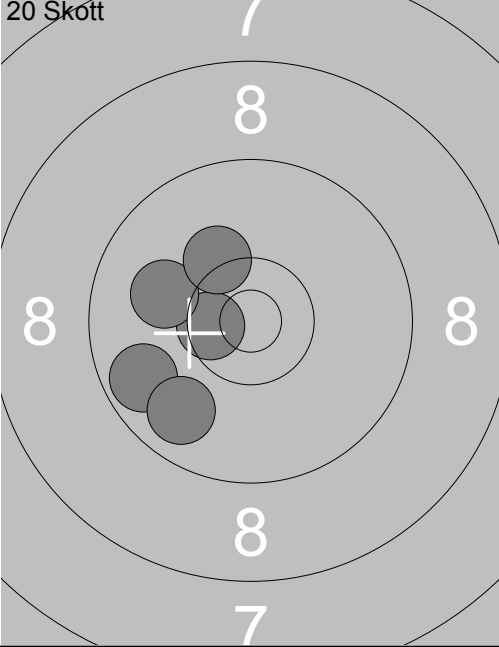
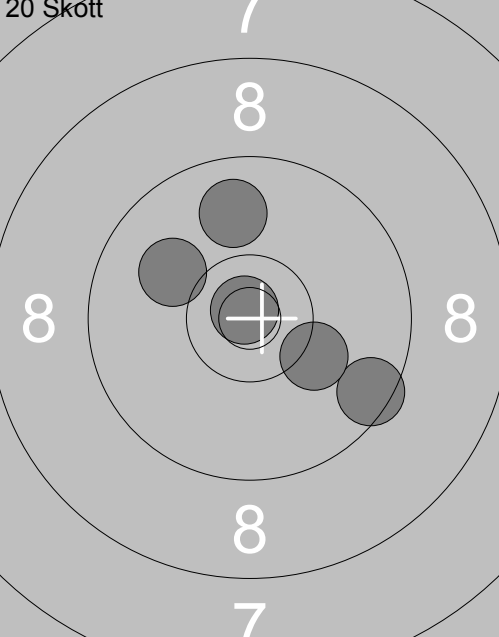
Skjutlag	Tavla	Jan-Ola Olsson			
2	5	Vindeln	Öved-Östraby	Sen-L	Sk
11.07.2017	Tavelträffen Korthåll 2017	Ramselefors SKF			
Prov		1: 9.7 ↗ 2: 9.0 ← 3: 9.4 ↗ 4: 9.2 ↗ 5: 10.3 ← 6: 8.9 ↘ 7: 9.8 ↓ 8: 9.8 →	20 Skott		1: 9.6 ↓ 2: 10.0 ↘ 3: 10.8x↘ 4: 9.8 ← 5: 9.7 ←
		Serie 72.0		Serie 47.0	
		Total 0.0		Total 47.0	
20 Skott		6: 8.4 ↘ 7: 10.6x↘ 8: 9.9 → 9: 10.8x→ 10: 10.3 ↓	20 Skott		11: 9.7 ← 12: 9.8 ↓ 13: 10.5x← 14: 10.0 ← 15: 10.2 ↗
		Serie 47.0		Serie 48.0	
		Total 94.0		Total 142.0	
20 Skott		16: 9.5 ↘ 17: 10.0 ↗ 18: 9.9 ↑ 19: 10.9x↗ 20: 10.2 ↘			
		Serie 48.0			
		Total 190.0			

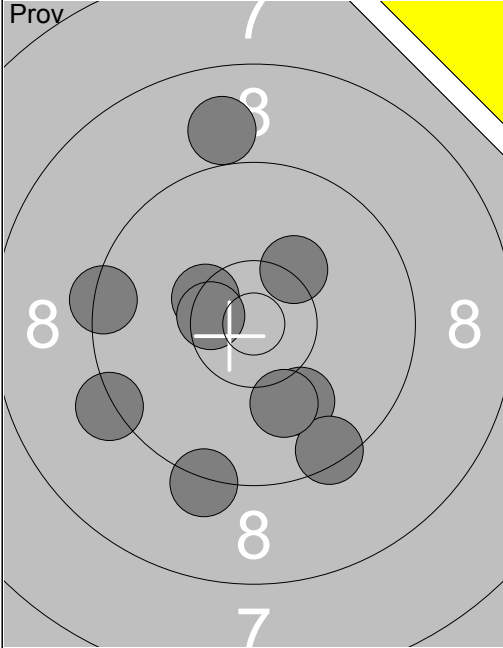
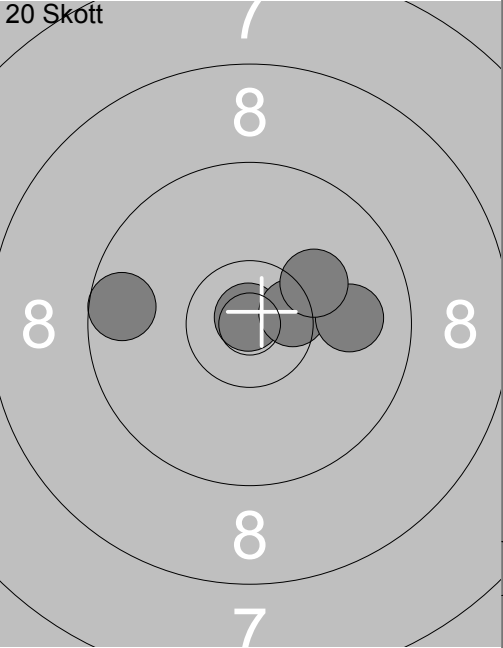
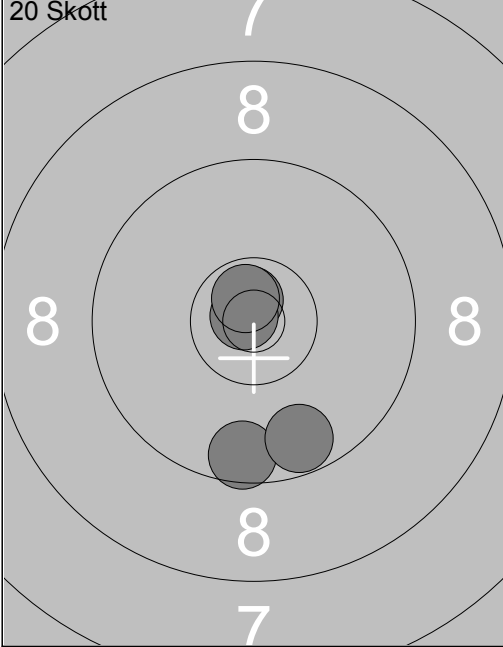
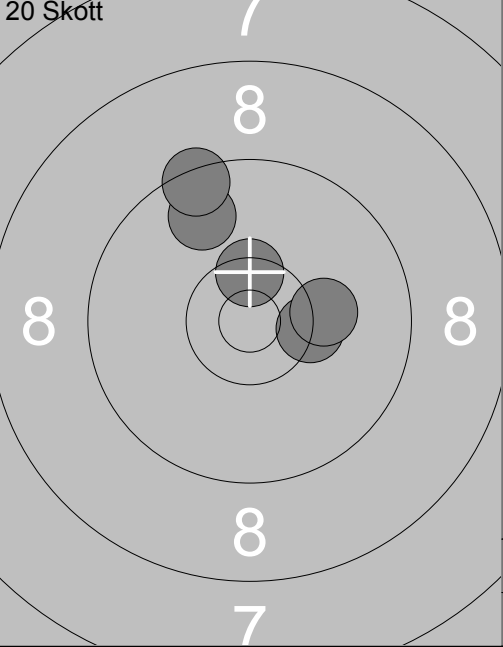
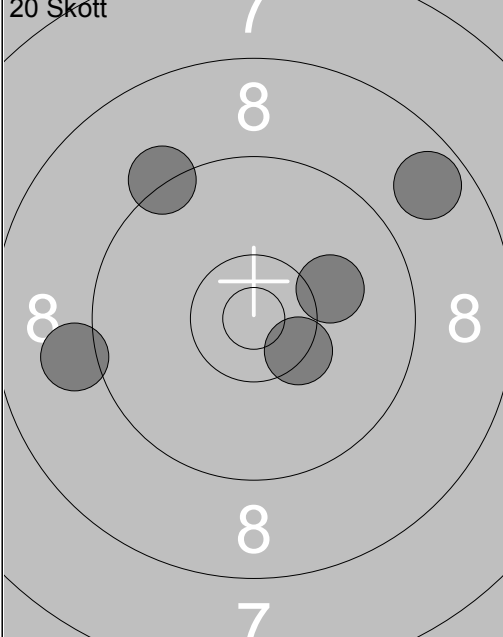
Skjutlag 2	Tavla 6	Henrik Olsson	
Vindeln	Öved-Östraby	Jun-L	Sk
11.07.2017	Tavelträffen Korthåll 2017	Ramselefors SKF	
Prov		20 Skott	
	1: 10.0 ↓ 2: 9.3 ↙ 3: 10.4 ↘ 4: 8.9 ↑ 5: 9.4 ← 6: 9.3 ↓ 7: 9.5 ↓ 8: 10.5 ↘ 9: 10.1 ↓ 10: 10.3 ↗		1: 10.9 ↗ 2: 10.5 ↘ 3: 9.9 → 4: 9.6 ← 5: 10.2 ↗
	Serie 94.0		Serie 48.0
	Total 0.0		Total 48.0
20 Skott		20 Skott	
	6: 10.7 ↗ 7: 9.6 ↓ 8: 10.8 ↘ 9: 10.7 ↗ 10: 9.7 ↓		11: 9.8 ↖ 12: 10.3 ↘ 13: 10.2 → 14: 9.4 ↖ 15: 10.5 ↗
	Serie 48.0		Serie 48.0
	Total 96.0		Total 144.0
20 Skott			
	16: 9.1 ← 17: 8.7 ↗ 18: 10.1 ↗ 19: 10.4 ↘ 20: 9.3 ↖		
	Serie 46.0		
	Total 190.0		

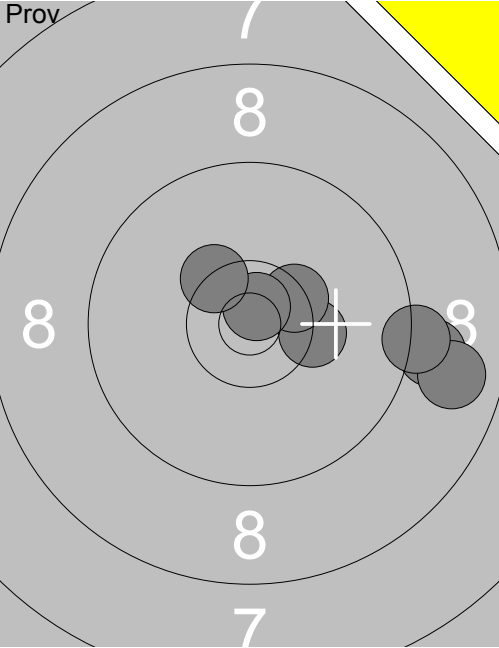
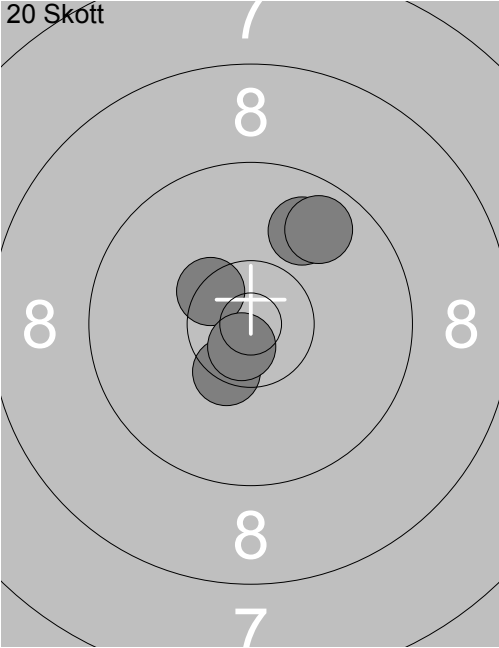
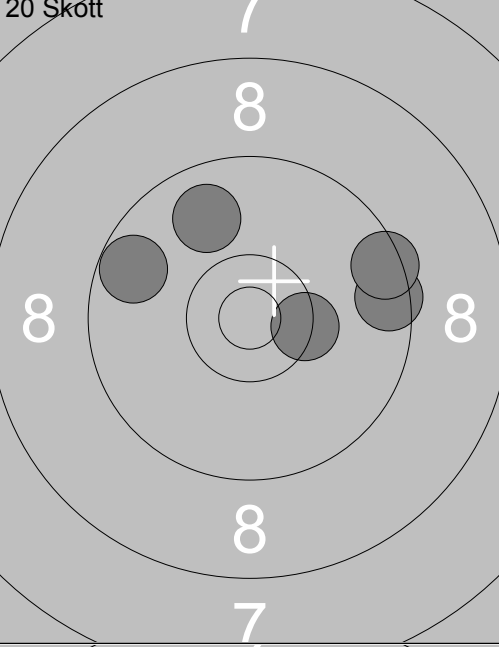
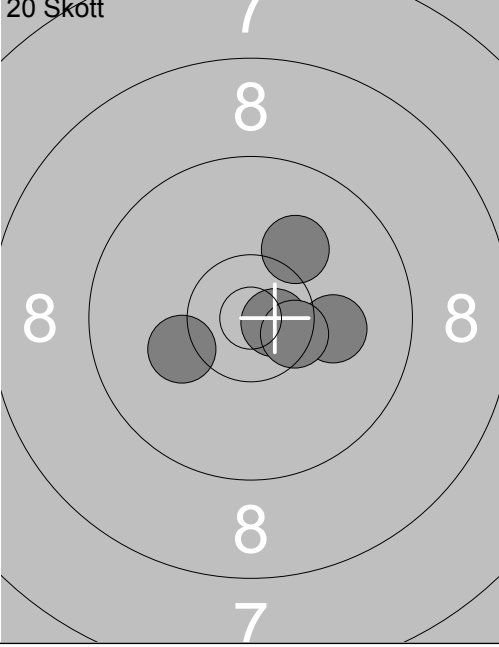
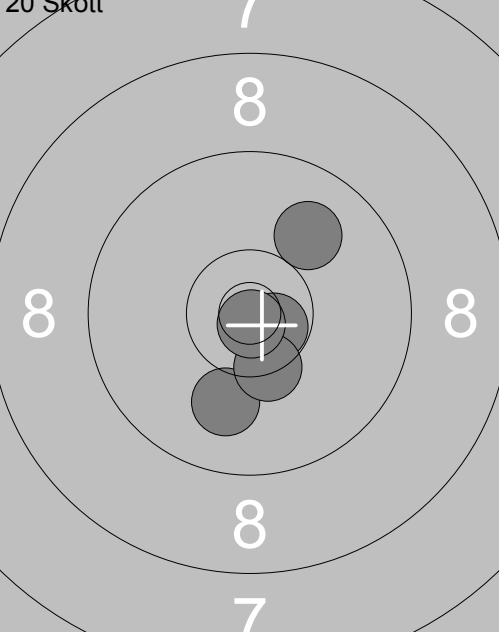
Skjutlag 2	Tavla 7	Ingemar Månsson			
Vindeln	Helsingborg			Sen-L	Sk
11.07.2017	Tavelträffen Korthåll 2017		Ramselefors SKF		
Prov		1: 9.1 → 2: 8.8 → 3: 10.3x→ 4: 9.2 → 5: 10.4x↗ 6: 10.8x↗ 7: 10.4x↘	20 Skott		1: 10.4x↘ 2: 9.9 ↗ 3: 10.4x↘ 4: 9.8 ↗ 5: 10.7x↘
		Serie 66.0			Serie 48.0
		Total 0.0			Total 48.0
20 Skott		6: 9.8 ↖ 7: 9.5 → 8: 9.5 → 9: 9.7 ↖ 10: 10.4x→	20 Skott		11: 10.2↙ 12: 10.1→ 13: 10.7x→ 14: 10.5x→ 15: 10.1 ↗
		Serie 46.0			Serie 50.0
		Total 94.0			Total 144.0
20 Skott		16: 10.7x↘ 17: 10.0 ↓ 18: 10.4x↘ 19: 10.0 ↗ 20: 10.8x↘			
		Serie 50.0			
		Total 194.0			

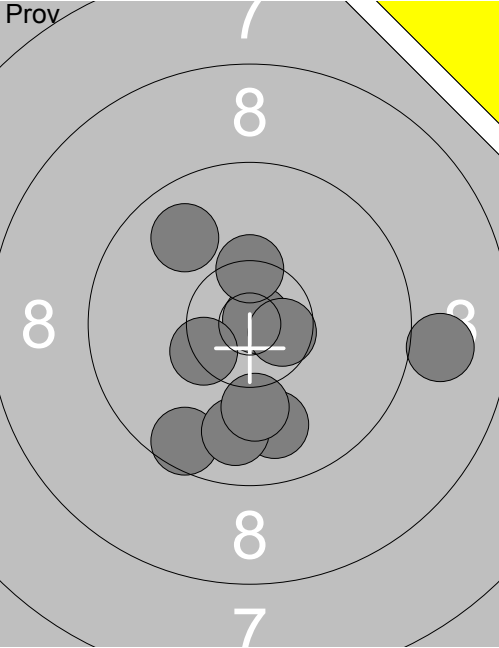
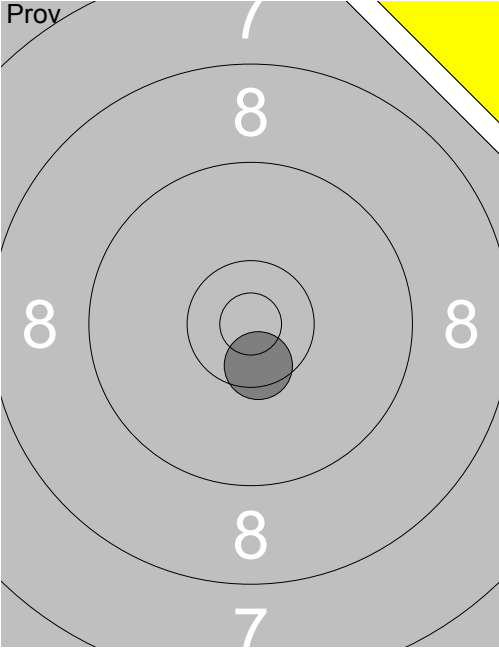
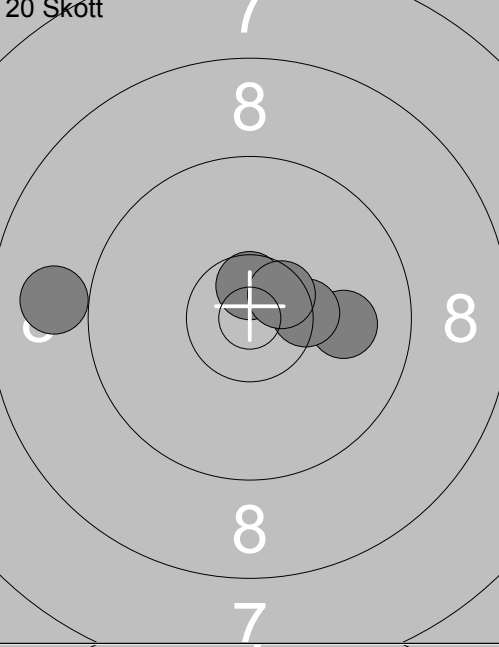
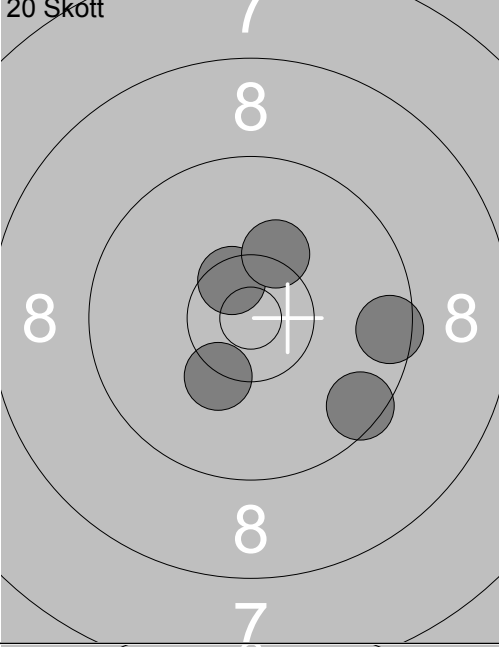
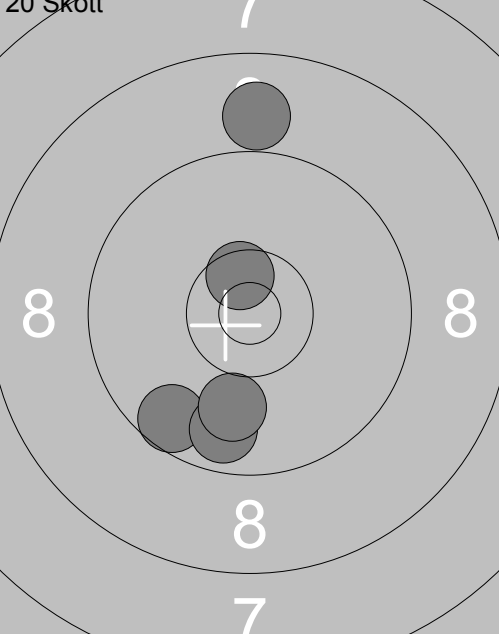
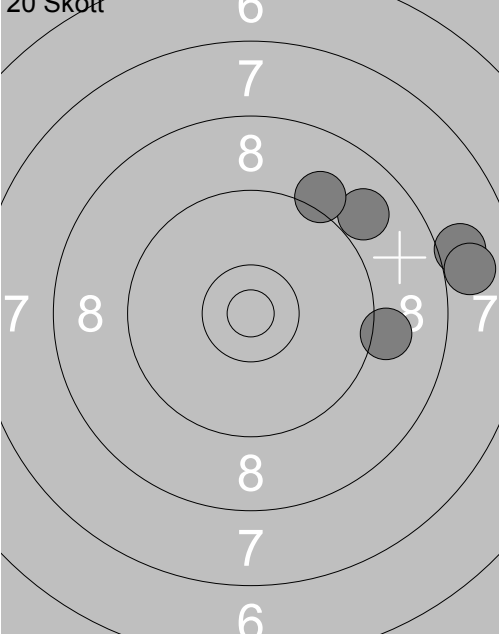
Skjuttag	Tavla	Johny Vadebo			
2	8	Helsingborg		Vet-L	Sk
11.07.2017		Tavelträffen Korthåll 2017		Ramselefors SKF	
Prov 	1: 10.9x ↗	Prov 	11: 10.5x ↓		
	2: 9.6 ↓				
	3: 10.4x ↑				
	4: 9.0 →				
	5: 9.8 ↖				
	6: 9.9 ↓				
	7: 9.8 ↓				
	8: 10.4x ↘				
	9: 10.1 ↓				
	10: 10.6x →				
	Serie 95.0		Serie 10.0		
	Total 0.0		Total 0.0		
20 Skott 	1: 10.0 →	20 Skott 	6: 10.5x ↗		
	2: 10.4x →		7: 9.5 ↓		
	3: 10.6x ↑		8: 10.2 ↑		
	4: 10.6x ↗		9: 9.5 →		
	5: 8.9 ←		10: 10.3 ↓		
	Serie 48.0		Serie 48.0		
	Total 48.0		Total 96.0		
20 Skott 	11: 9.6 ↓	20 Skott 	16: 8.0 →		
	12: 9.7 ↓		17: 7.9 →		
	13: 8.9 ↑		18: 8.9 ↗		
	14: 10.6x ↑		19: 9.1 ↑		
	15: 10.0 ↓		20: 9.1 →		
	Serie 46.0		Serie 41.0		
	Total 142.0		Total 183.0		

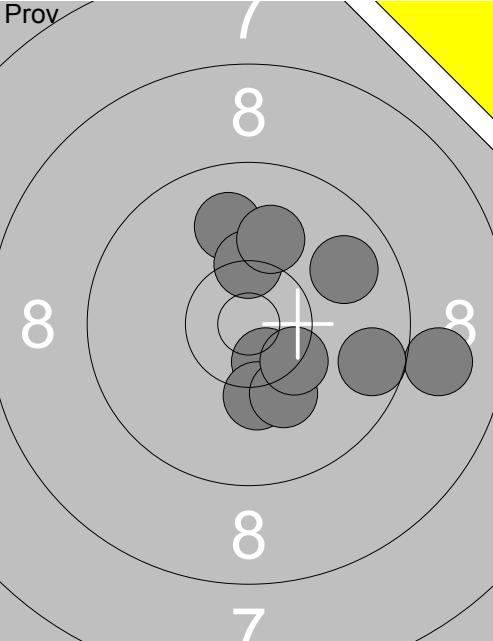
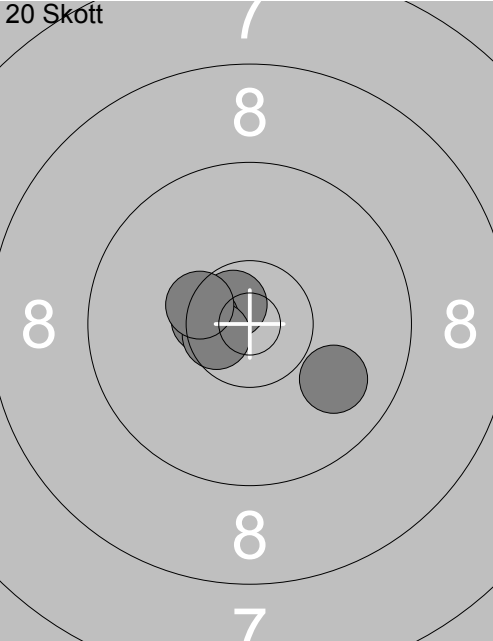
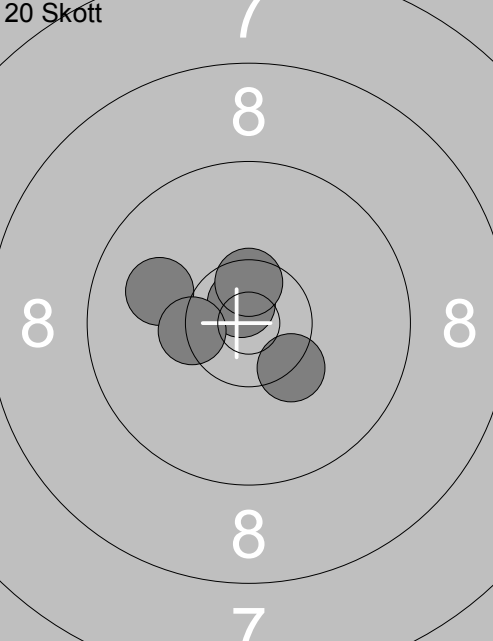
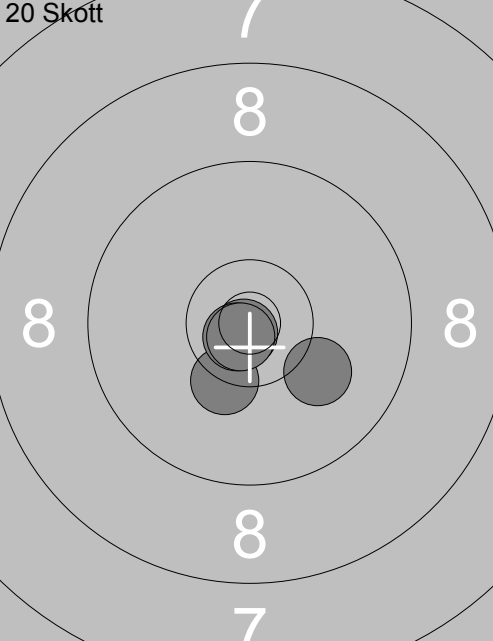
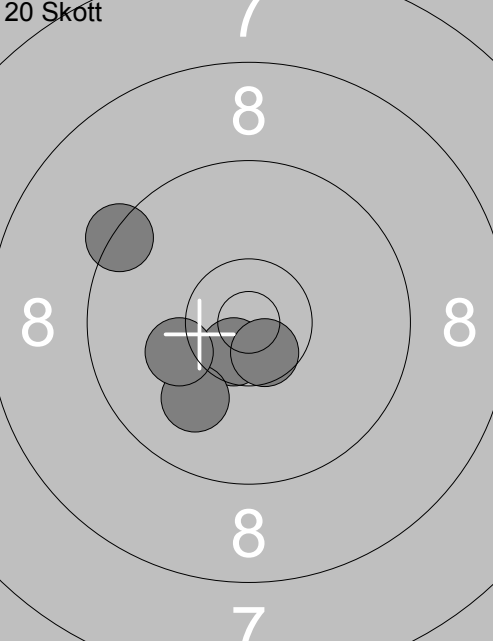
Skjuttag	Tavla	Markus Andersson			
2	9	Bälinge-Jumkil		Sen-L	Up
11.07.2017		Tavelträffen Korthåll 2017		Ramselefors SKF	
Prov 	1: 9.9 ↗	20 Skott 	1: 9.9 ↘		
	2: 10.3x↗		2: 10.7x↘		
	3: 10.1 ↗		3: 10.5x↖		
	4: 10.5x↘		4: 10.6x↖		
	5: 9.0 →		5: 10.4x↖		
	6: 10.2 ↓				
	7: 9.6 →				
	8: 9.8 ↗				
	9: 10.2 ↓				
	10: 10.4x↘				
	Serie 96.0		Serie 49.0		
	Total 0.0		Total 49.0		
20 Skott 	6: 10.0 ↖	20 Skott 	11: 10.3x↘		
	7: 10.3x↘		12: 10.8x↘		
	8: 10.7x↘		13: 10.8x↘		
	9: 10.4x↖		14: 10.8x↘		
	10: 10.5x↗		15: 10.1 ↘		
	Serie 50.0		Serie 50.0		
	Total 99.0		Total 149.0		
20 Skott 	16: 10.6x↘				
	17: 10.0 ↘				
	18: 10.6x↘				
	19: 9.4 ↖				
	20: 10.2 ↖				
	Serie 49.0				
	Total 198.0				

<p>Prov</p>	<p>1: 8.1 ↘ 2: 6.1 ↘ 3: 6.7 ↘ 4: 8.2 ↘ 5: 9.5 ↘ 6: 7.2 ↘ 7: 7.4 ↘ 8: 10.7x ↘ 9: 9.4 → 10: 10.1 ↓</p> <p>Serie 80.0 Total 0.0</p>	<p>Prov</p>	<p>11: 10.1 ↖ 12: 9.9 → 13: 9.6 → 14: 10.1 ↑</p> <p>Serie 38.0 Total 0.0</p>
<p>20 Skott</p>	<p>1: 6.7 ↓ 2: 8.3 ↓ 3: 9.9 ↖ 4: 10.0 → 5: 8.4 ↓</p> <p>Serie 41.0 Total 41.0</p>	<p>20 Skott</p>	<p>6: 7.5 ↓ 7: 10.0 ↗ 8: 9.2 → 9: 9.2 ↓ 10: 10.4x ↓</p> <p>Serie 45.0 Total 86.0</p>
<p>20 Skott</p>	<p>11: 10.3 → 12: 9.7 ↓ 13: 9.8 ↓ 14: 9.9 → 15: 10.2 ↓</p> <p>Serie 47.0 Total 133.0</p>	<p>20 Skott</p>	<p>16: 10.0 ↙ 17: 8.2 ↓ 18: 10.2 → 19: 10.0 ↓ 20: 10.6x ↓</p> <p>Serie 48.0 Total 181.0</p>

Prov 	Prov 	
1: 7.7 ↖ 2: 10.7x ↗ 3: 9.7 ↘ 4: 9.5 → 5: 8.5 ↗ 6: 8.5 ↗ 7: 10.6x ↗ 8: 9.8 ↗ 9: 7.5 ↑ 10: 10.1 ↗	11: 10.2 ↗ 12: 9.8 ↑ 13: 9.4 ↑ 14: 8.0 ↖	
Serie 87.0	Serie 36.0	
Total 0.0	Total 0.0	

20 Skott 	20 Skott 	
1: 9.5 ↖ 2: 8.5 ↖ 3: 9.5 ↖ 4: 8.7 ↗ 5: 10.9x ↓	6: 7.5 ↗ 7: 9.1 → 8: 8.7 ↗ 9: 9.9 ↑ 10: 10.1 ←	
Serie 44.0	Serie 43.0	
Total 44.0	Total 87.0	

20 Skott 	20 Skott 	
11: 10.1 ↑ 12: 9.2 → 13: 10.2 ↓ 14: 9.1 ← 15: 10.8x ←	16: 10.3 → 17: 10.1 ↗ 18: 8.4 ↓ 19: 8.1 ↑ 20: 9.3 ↓	
Serie 48.0	Serie 45.0	
Total 135.0	Total 180.0	

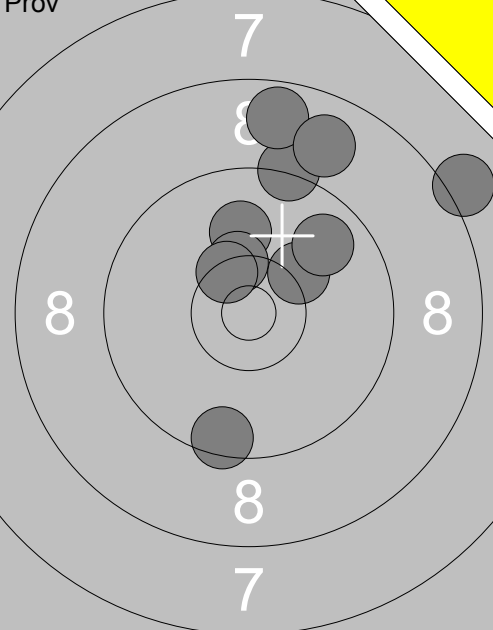
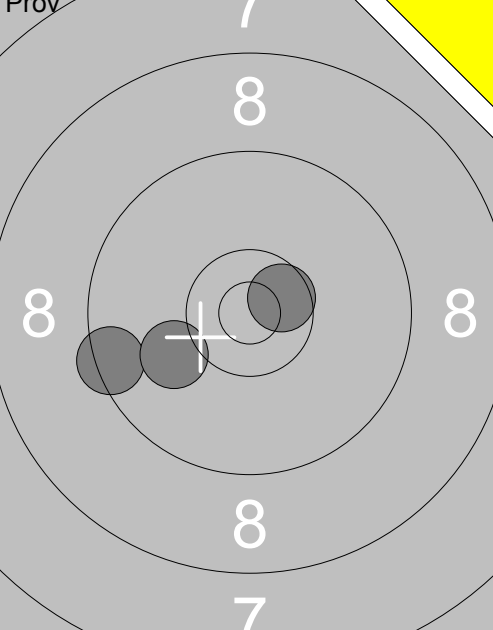
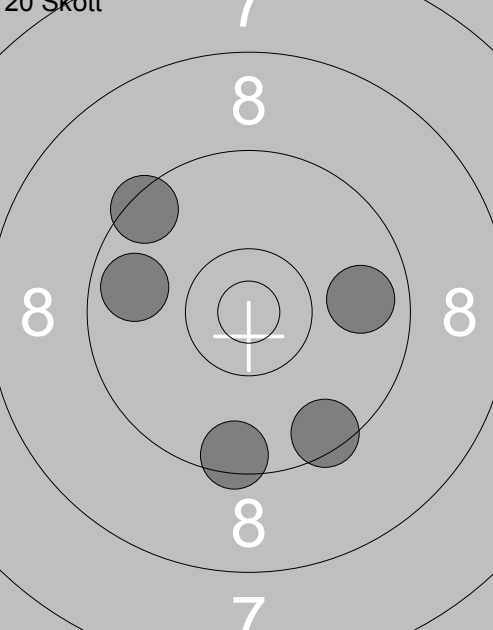
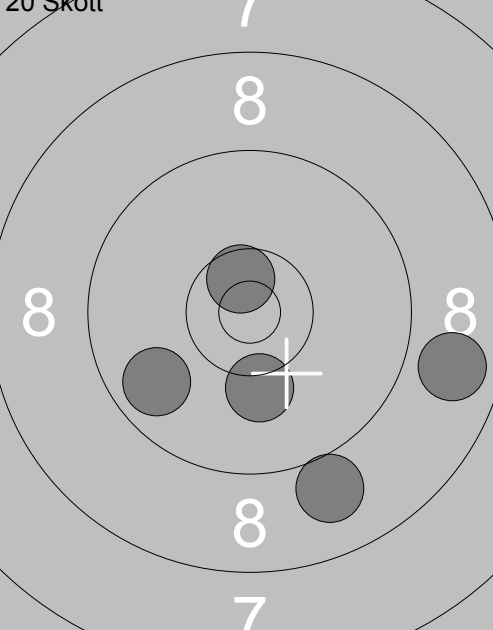
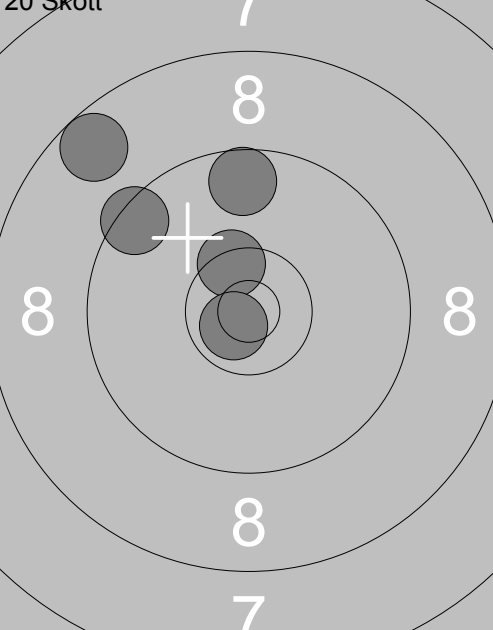
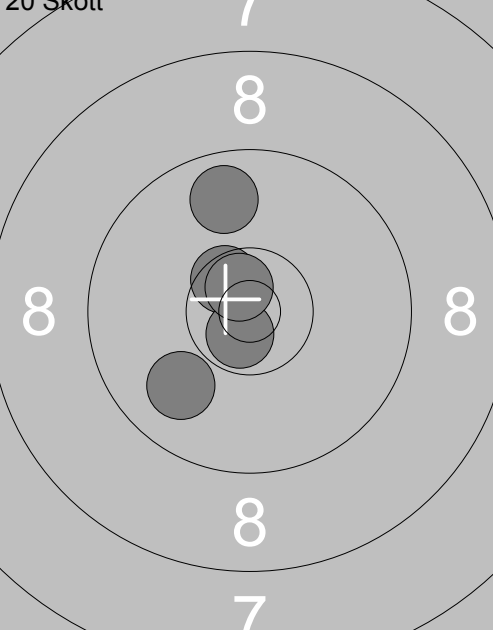
<p>Prov</p>  <p style="text-align: center;">7 8 8 8 8 7</p>	<p>1: 9.3 ↑ 2: 10.2 ↗ 3: 8.1 ↗ 4: 8.7 ↑ 5: 9.5 ↓ 6: 10.0 ↑ 7: 10.4x ↗ 8: 8.9 ↗ 9: 10.4x ↘ 10: 9.8 ↗</p> <p>Serie 91.0 Total 0.0</p>	<p>Prov</p>  <p style="text-align: center;">7 8 8 8 7</p>	<p>11: 9.5 ← 12: 10.1 ↙ 13: 10.6x ↗</p> <p>Serie 29.0 Total 0.0</p>
<p>20 Skott</p>  <p style="text-align: center;">7 8 8 8 7</p>	<p>1: 9.8 → 2: 9.8 ← 3: 9.5 ↓ 4: 9.5 ↗ 5: 9.5 ↓</p> <p>Serie 45.0 Total 45.0</p>	<p>20 Skott</p>  <p style="text-align: center;">7 8 8 8 7</p>	<p>6: 9.8 ← 7: 8.8 → 8: 10.2 ↓ 9: 9.0 ↓ 10: 10.6x ↗</p> <p>Serie 46.0 Total 91.0</p>
<p>20 Skott</p>  <p style="text-align: center;">7 8 8 7</p>	<p>11: 10.4x ↘ 12: 9.6 ↑ 13: 8.6 ↙ 14: 9.5 ↙ 15: 10.7x ↘</p> <p>Serie 46.0 Total 137.0</p>	<p>20 Skott</p>  <p style="text-align: center;">7 8 8 7</p>	<p>16: 10.5x ↘ 17: 10.7x ↘ 18: 10.7x ↗ 19: 9.8 ↑ 20: 9.9 ↙</p> <p>Serie 48.0 Total 185.0</p>

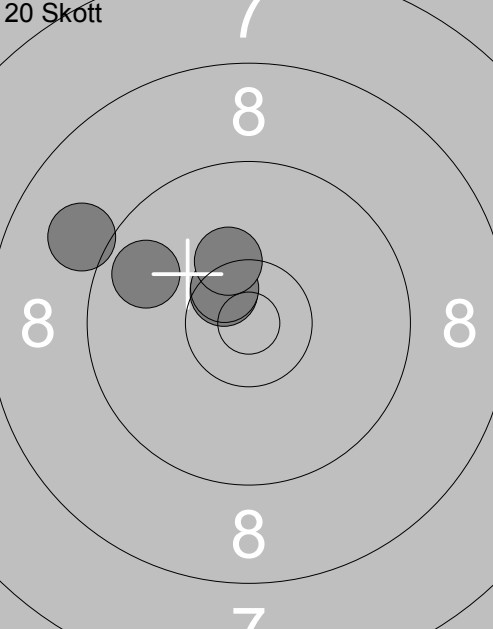
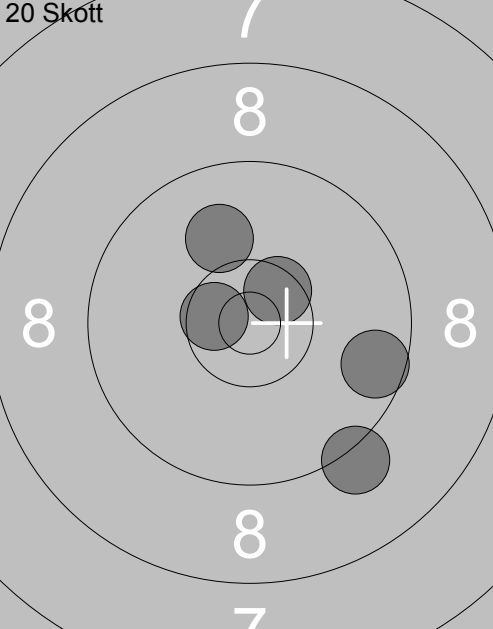
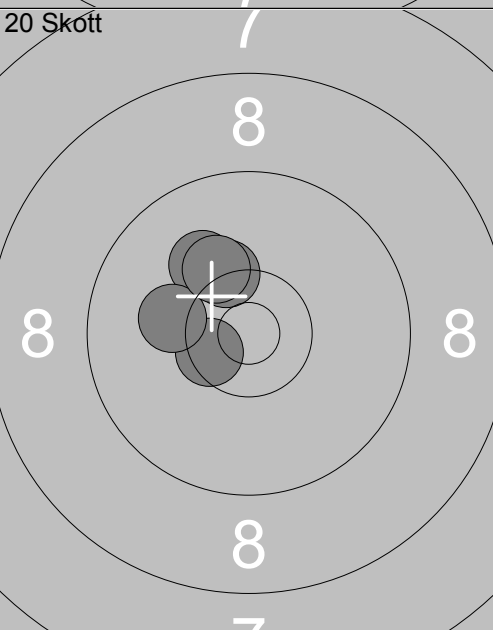
 <p style="font-size: 8pt;">Prov</p>	<p>20 Skott</p> <p>1: 8.6 ↗ 2: 10.3x↔ 3: 9.3 ↘ 4: 9.3 ↘ 5: 10.1↔ 6: 9.4 → 7: 10.3x↘ 8: 8.9 ↘ 9: 10.1 ↘ 10: 10.6x↗</p> <p>Serie 93.0 Total 0.0</p>	 <p>20 Skott</p> <p>1: 9.8 ← 2: 10.2 ↓ 3: 9.8 ↘ 4: 9.9 ↘ 5: 9.6 ↘</p> <p>Serie 46.0 Total 46.0</p>
 <p>20 Skott</p>	<p>6: 9.0 ← 7: 9.8 ← 8: 10.5x↗ 9: 10.5x↗ 10: 10.3 ↑</p> <p>Serie 48.0 Total 94.0</p>	 <p>20 Skott</p> <p>11: 10.6x↔ 12: 10.0 ↑ 13: 10.5x↗ 14: 9.6 → 15: 9.2 ↘</p> <p>Serie 48.0 Total 142.0</p>
 <p>20 Skott</p>	<p>16: 10.1 ↗ 17: 10.5x↔ 18: 10.3x↗ 19: 10.2↔ 20: 10.2 ↗</p> <p>Serie 50.0 Total 192.0</p>	

<p>Prov</p>	<p>20 Skott</p> <p>1: 8.3 ↑ 2: 9.0 ↗ 3: 9.9 → 4: 7.5 ↑ 5: 9.8 ↖ 6: 10.2 ↓ 7: 10.8x ↙ 8: 7.5 ↓ 9: 9.9 ↑ 10: 8.9 ↗</p> <p>Serie 86.0 Total 0.0</p>	<p>20 Skott</p> <p>1: 10.4x ↗ 2: 10.4x ↘ 3: 8.6 ↖ 4: 9.9 ↑ 5: 10.4x ↘</p> <p>Serie 47.0 Total 47.0</p>
<p>20 Skott</p>	<p>6: 10.3x ↙ 7: 9.2 ↖ 8: 9.7 → 9: 9.9 ← 10: 10.3 ↙</p> <p>Serie 47.0 Total 94.0</p>	<p>20 Skott</p> <p>11: 10.1 ↗ 12: 9.0 ↑ 13: 8.9 ↓ 14: 9.3 → 15: 10.1 ↓</p> <p>Serie 46.0 Total 140.0</p>
<p>20 Skott</p>	<p>16: 9.0 ↑ 17: 10.1 ↖ 18: 10.6x ↓ 19: 7.8 ↗ 20: 9.7 ↗</p> <p>Serie 45.0 Total 185.0</p>	

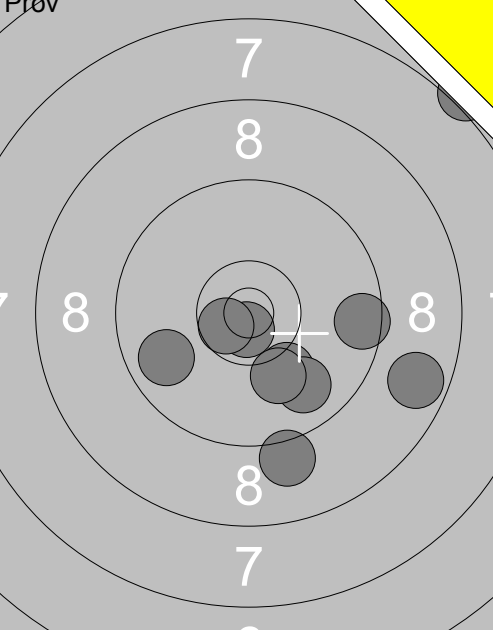
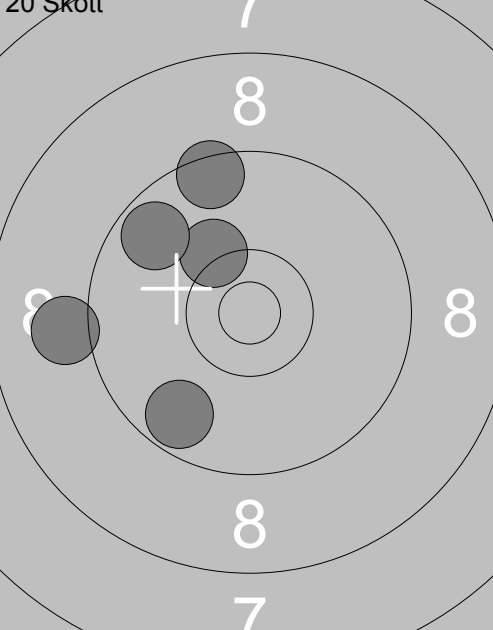
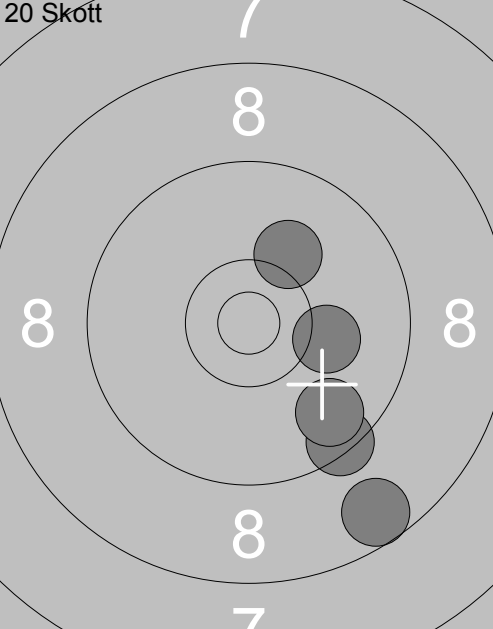
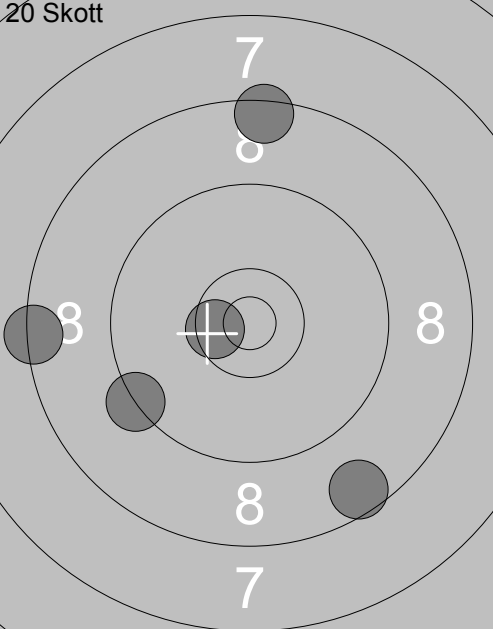
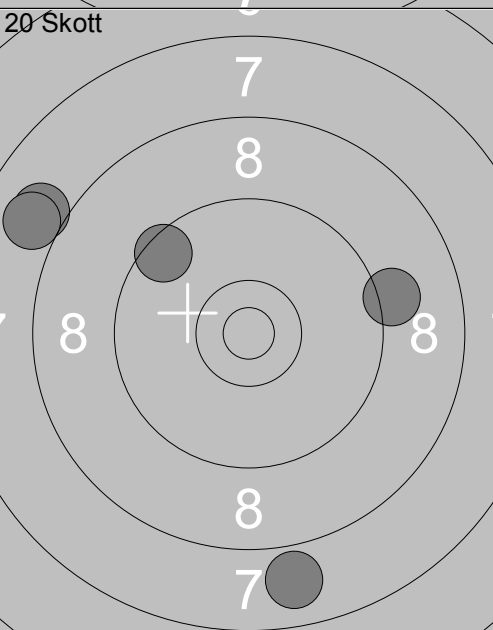
<p>Pröv</p> 	<p>20 Skott</p> 	<p>1: 7.1 ↗ 2: 10.1 ↓ 3: 10.7x↓ 4: 9.8 ↓ 5: 9.8 ← 6: 8.7 → 7: 10.1 ↓ 8: 9.5 → 9: 10.6x↙ 10: 9.1 ↓</p> <p>Serie 91.0 Total 0.0</p>	<p>1: 9.5 ↑ 2: 10.2 ↖ 3: 9.7 ↖ 4: 9.7 ↓ 5: 9.1 ←</p> <p>Serie 46.0 Total 46.0</p>
<p>20 Skott</p> 	<p>20 Skott</p> 	<p>6: 9.4 ↓ 7: 10.1 ↗ 8: 9.7 ↓ 9: 8.6 ↓ 10: 10.1 →</p> <p>Serie 46.0 Total 92.0</p>	<p>11: 8.4 ← 12: 10.5x↙ 13: 8.5 ↑ 14: 9.3 ↙ 15: 8.6 ↓</p> <p>Serie 43.0 Total 135.0</p>
<p>20 Skott</p> 	<p>16: 9.5 ↖ 17: 8.0 ↖ 18: 9.1 → 19: 8.0 ↖ 20: 7.9 ↓</p> <p>Serie 41.0 Total 176.0</p>		

	<p>1: 8.5 ↗</p> <p>2: 10.7x ↘</p> <p>3: 7.5 ↗</p> <p>4: 7.2 ↑</p> <p>5: 9.9 ↓</p> <p>6: 8.9 ↑</p> <p>7: 9.5 ↑</p> <p>8: 7.5 ↑</p> <p>9: 10.0 →</p> <p>10: 7.8 ↑</p> <p>Serie 82.0</p> <p>Total 0.0</p>		<p>11: 6.9 ↖</p> <p>12: 9.4 ↗</p> <p>13: 7.3 ↑</p> <p>14: 10.4x ↗</p> <p>Serie 32.0</p> <p>Total 0.0</p>
<p>20 Skott</p>	<p>1: 9.3 ↑</p> <p>2: 8.8 ↑</p> <p>3: 9.2 ↑</p> <p>4: 10.8x ↖</p> <p>5: 7.7 ↗</p> <p>Serie 43.0</p> <p>Total 43.0</p>	<p>20 Skott</p>	<p>6: 9.7 ↖</p> <p>7: 10.5x ↗</p> <p>8: 8.9 ↑</p> <p>9: 7.1 ↑</p> <p>10: 8.2 ↑</p> <p>Serie 42.0</p> <p>Total 85.0</p>
<p>20 Skott</p>	<p>11: 8.3 ↑</p> <p>12: 7.0 ↑</p> <p>13: 9.7 ↗</p> <p>14: 9.4 ↑</p> <p>15: 8.8 ↖</p> <p>Serie 41.0</p> <p>Total 126.0</p>	<p>20 Skott</p>	<p>16: 8.7 ↗</p> <p>17: 9.4 ↑</p> <p>18: 7.3 ↖</p> <p>19: 9.0 ↖</p> <p>20: 9.6 →</p> <p>Serie 42.0</p> <p>Total 168.0</p>

<p>Prov</p>	<p>1: 7.5 ←</p> <p>2: 8.2 →</p> <p>3: 8.2 ↓</p> <p>4: 8.5 →</p> <p>5: 9.6 →</p> <p>6: 9.7 ↓</p> <p>7: 9.2 ↓</p> <p>8: 10.4x ↘</p> <p>9: 9.2 ↗</p> <p>10: 10.3x ↘</p>	<p>Prov</p>
Serie 87.0		Serie 9.0
Total 0.0		Total 0.0
<p>20 Skott</p>	<p>1: 9.4 ←</p> <p>2: 10.2 ↓</p> <p>3: 8.9 ←</p> <p>4: 9.0 ↗</p> <p>5: 9.7 ↗</p>	<p>20 Skott</p>
Serie 45.0		Serie 39.0
Total 45.0		Total 84.0
<p>20 Skott</p>	<p>11: 9.3 ↗</p> <p>12: 10.4x ↗</p> <p>13: 9.2 ↗</p> <p>14: 9.4 ↗</p> <p>15: 10.3x ↗</p>	<p>20 Skott</p>
Serie 47.0		Serie 44.0
Total 131.0		Total 175.0

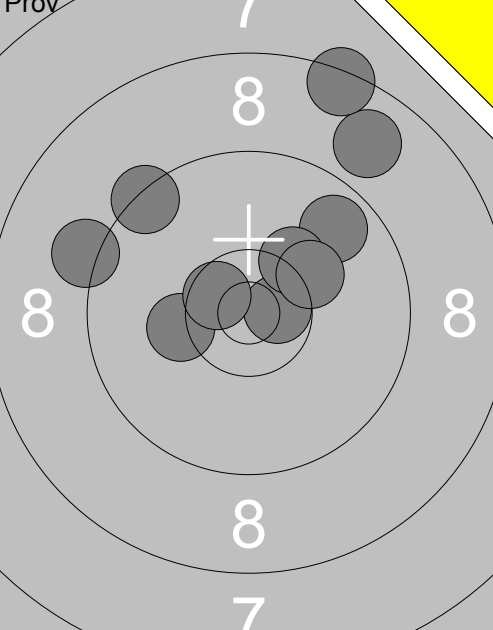
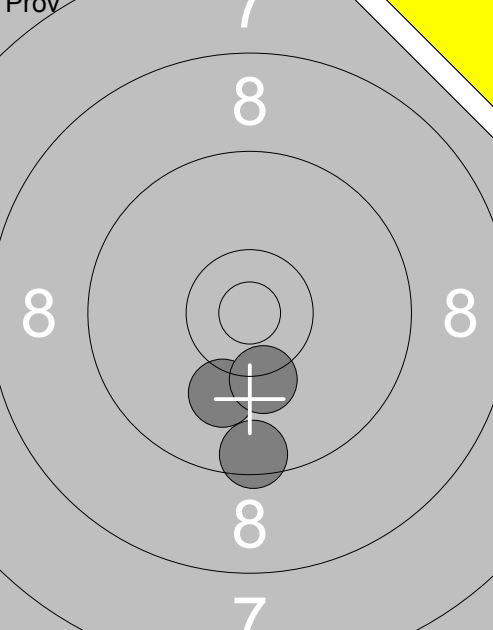
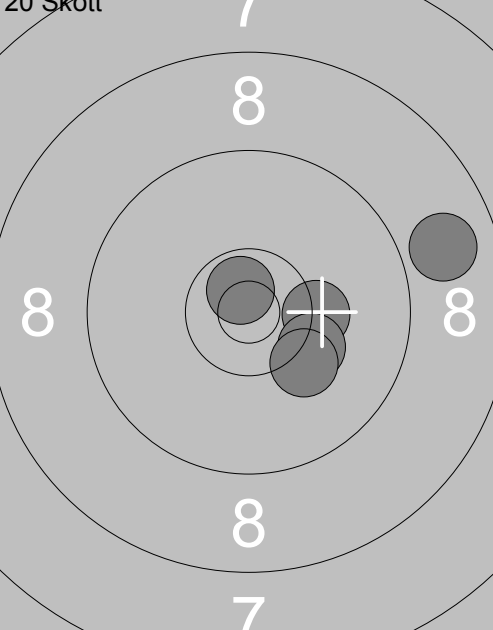
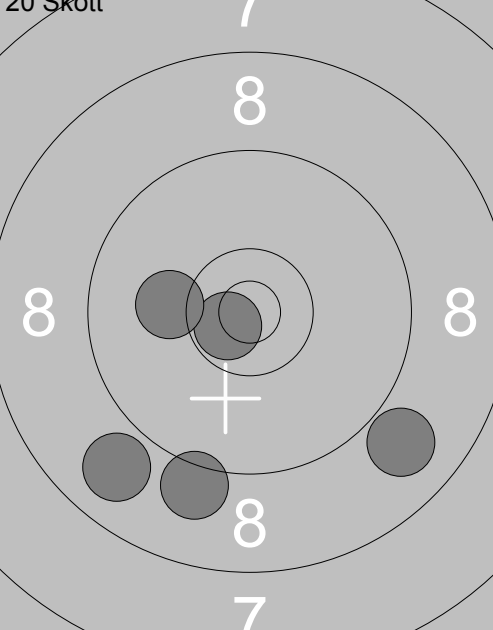
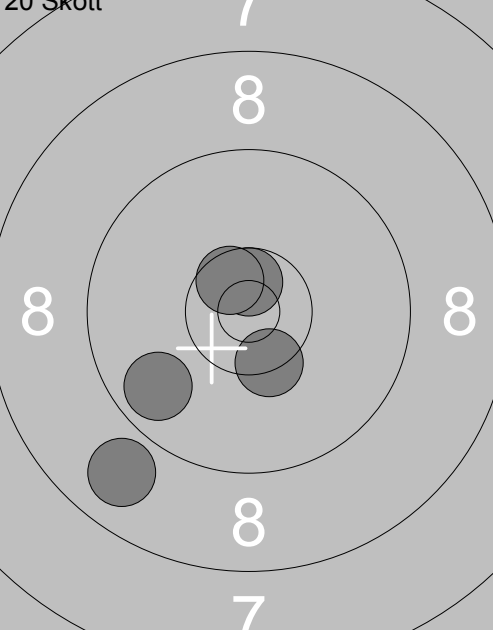
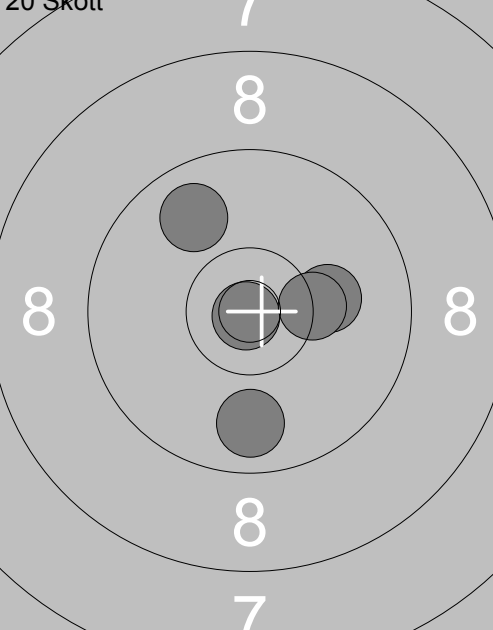
<div style="text-align: center;">Prov</div> 	1: 8.8 ↗ 2: 9.2 ← 3: 9.4 ↖ 4: 8.4 ↗ 5: 10.7x→ 6: 9.7 ↗ 7: 10.2← 8: 10.3 ↗ 9: 10.6x↘ 10: 10.2 ↗ <hr/> Serie 93.0 Total 0.0	<div style="text-align: center;">Prov</div> 	11: 10.1 ↓ 12: 10.3 ↓ 13: 9.5 ↓ <hr/> Serie 29.0 Total 0.0
<div style="text-align: center;">20 Skott</div> 	1: 10.3→ 2: 10.7x↗ 3: 10.2↘ 4: 8.9→ 5: 10.2↘ <hr/> Serie 48.0 Total 48.0	<div style="text-align: center;">20 Skott</div> 	6: 8.9 ↙ 7: 10.7x↘ 8: 9.1 ↓ 9: 10.1← 10: 8.9 ↘ <hr/> Serie 45.0 Total 93.0
<div style="text-align: center;">20 Skott</div> 	11: 10.7x↗ 12: 10.4x↘ 13: 8.9 ↙ 14: 9.8 ↙ 15: 10.6x↘ <hr/> Serie 47.0 Total 140.0	<div style="text-align: center;">20 Skott</div> 	16: 10.1→ 17: 10.9x↘ 18: 10.3x→ 19: 9.8 ↓ 20: 9.8 ↖ <hr/> Serie 48.0 Total 188.0

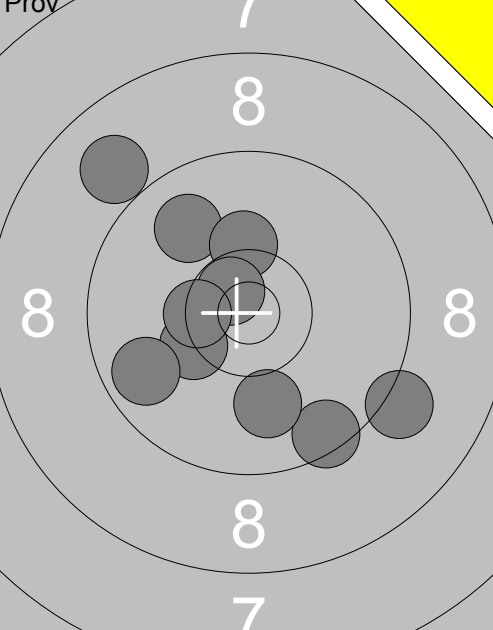
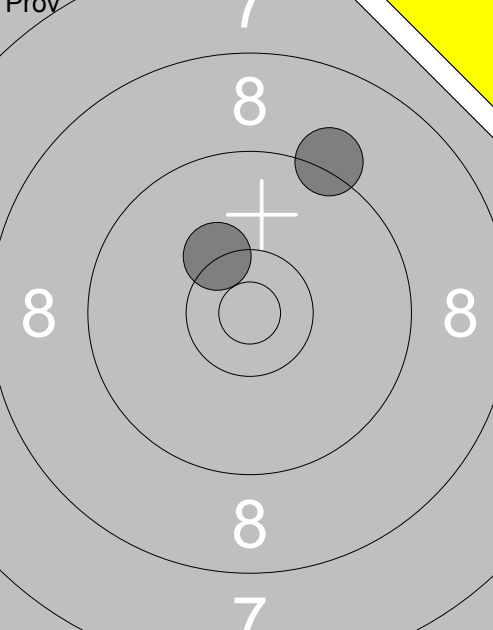
<div style="text-align: center;">Prov</div> 	<div style="text-align: center;">Prov</div> 	<div style="text-align: center;">11: 9.2 ↗</div> <div style="text-align: center;">12: 10.3 ↖</div>
<div style="text-align: center;">8</div> <div style="text-align: center;">8</div> <div style="text-align: center;">8</div> <div style="text-align: center;">8</div> <div style="text-align: center;">8</div> <div style="text-align: center;">8</div> <div style="text-align: center;">8</div> <div style="text-align: center;">8</div> <div style="text-align: center;">8</div> <div style="text-align: center;">8</div>	<div style="text-align: center;">1: 9.2 ↘</div> <div style="text-align: center;">2: 8.9 ↖</div> <div style="text-align: center;">3: 10.3 ✕</div> <div style="text-align: center;">4: 9.7 ↙</div> <div style="text-align: center;">5: 9.9 ↗</div> <div style="text-align: center;">6: 9.5 ↘</div> <div style="text-align: center;">7: 10.0 ↓</div> <div style="text-align: center;">8: 10.3 ↑</div> <div style="text-align: center;">9: 10.7 ✕</div> <div style="text-align: center;">10: 10.4 ✕</div>	<div style="text-align: center;">8</div> <div style="text-align: center;">8</div> <div style="text-align: center;">8</div> <div style="text-align: center;">8</div> <div style="text-align: center;">8</div> <div style="text-align: center;">8</div> <div style="text-align: center;">8</div> <div style="text-align: center;">8</div> <div style="text-align: center;">8</div> <div style="text-align: center;">8</div>
Serie 94.0	Serie 19.0	Serie 19.0
Total 0.0	Total 0.0	Total 0.0
20 Skott	20 Skott	20 Skott
<div style="text-align: center;">8</div> <div style="text-align: center;">8</div> <div style="text-align: center;">8</div> <div style="text-align: center;">8</div> <div style="text-align: center;">8</div> <div style="text-align: center;">8</div> <div style="text-align: center;">8</div> <div style="text-align: center;">8</div> <div style="text-align: center;">8</div> <div style="text-align: center;">8</div>	<div style="text-align: center;">8</div> <div style="text-align: center;">8</div> <div style="text-align: center;">8</div> <div style="text-align: center;">8</div> <div style="text-align: center;">8</div> <div style="text-align: center;">8</div> <div style="text-align: center;">8</div> <div style="text-align: center;">8</div> <div style="text-align: center;">8</div> <div style="text-align: center;">8</div>	<div style="text-align: center;">6: 8.9 →</div> <div style="text-align: center;">7: 10.8 ✕</div> <div style="text-align: center;">8: 10.4 ↓</div> <div style="text-align: center;">9: 10.4 ✕</div> <div style="text-align: center;">10: 10.6 ✕</div>
Serie 46.0	Serie 48.0	Serie 48.0
Total 46.0	Total 94.0	Total 94.0
20 Skott	20 Skott	20 Skott
<div style="text-align: center;">8</div> <div style="text-align: center;">8</div> <div style="text-align: center;">8</div> <div style="text-align: center;">8</div> <div style="text-align: center;">8</div> <div style="text-align: center;">8</div> <div style="text-align: center;">8</div> <div style="text-align: center;">8</div> <div style="text-align: center;">8</div> <div style="text-align: center;">8</div>	<div style="text-align: center;">8</div> <div style="text-align: center;">8</div> <div style="text-align: center;">8</div> <div style="text-align: center;">8</div> <div style="text-align: center;">8</div> <div style="text-align: center;">8</div> <div style="text-align: center;">8</div> <div style="text-align: center;">8</div> <div style="text-align: center;">8</div> <div style="text-align: center;">8</div>	<div style="text-align: center;">16: 10.5 ✕</div> <div style="text-align: center;">17: 9.5 ↙</div> <div style="text-align: center;">18: 10.1 →</div> <div style="text-align: center;">19: 10.4 ✕</div> <div style="text-align: center;">20: 9.6 ↖</div>
Serie 49.0	Serie 48.0	Serie 48.0
Total 143.0	Total 191.0	Total 191.0

<p>Prov</p>	<p>1: 7.4 ↓ 2: 8.4 ↙ 3: 9.1 ← 4: 8.9 ↙ 5: 8.8 ↙ 6: 10.6x↓ 7: 9.8 ➤ 8: 10.1 ↙ 9: 10.1 ↗ 10: 9.2 ↖</p> <p>Serie 88.0 Total 0.0</p>	<p>Prov</p>	<p>11: 9.1 ↖</p> <p>Serie 9.0 Total 0.0</p>
<p>20 Skott</p>	<p>1: 9.7 ↙ 2: 9.6 ← 3: 9.4 ↑ 4: 10.7x↑ 5: 10.8x↓</p> <p>Serie 47.0 Total 47.0</p>	<p>20 Skott</p>	<p>6: 9.8 ↑ 7: 10.2↙ 8: 10.0 ↑ 9: 9.6 ➤ 10: 8.5 ➤</p> <p>Serie 46.0 Total 93.0</p>
<p>20 Skott</p>	<p>11: 10.0 ➤ 12: 8.8 ↑ 13: 8.5 ↗ 14: 9.7 ↑ 15: 10.4x↓</p> <p>Serie 45.0 Total 138.0</p>	<p>20 Skott</p>	<p>16: 8.6 ↓ 17: 10.6x↗ 18: 10.7x↖ 19: 9.9 ➤ 20: 10.6x➤</p> <p>Serie 47.0 Total 185.0</p>

<p>Prov</p>	<p>1: 9.2 ↓ 2: 9.4 ← 3: 10.6x ↗ 4: 10.8x ↗ 5: 10.3 ↖ 6: 9.5 ↖ 7: 9.8 ↖ 8: 10.5x ↓ 9: 8.5 ← 10: 9.8 ↖</p> <p>Serie 93.0 Total 0.0</p>	<p>Prov</p>	<p>11: 10.0 ← 12: 9.9 ←</p> <p>Serie 19.0 Total 0.0</p>
<p>20 Skott</p>	<p>1: 9.9 ↗ 2: 10.6x ↗ 3: 9.3 ↑ 4: 9.9 ↘ 5: 9.1 →</p> <p>Serie 46.0 Total 46.0</p>	<p>20 Skott</p>	<p>6: 9.8 → 7: 10.4x ↘ 8: 9.9 ↘ 9: 10.4x ↓ 10: 10.2 ↘</p> <p>Serie 48.0 Total 94.0</p>
<p>20 Skott</p>	<p>11: 10.1 → 12: 10.3 ↗ 13: 9.8 ↑ 14: 10.2 ↓ 15: 9.9 ↓</p> <p>Serie 48.0 Total 142.0</p>	<p>20 Skott</p>	<p>16: 10.7x ↘ 17: 10.2 ↑ 18: 10.5x ↘ 19: 10.6x ← 20: 9.6 →</p> <p>Serie 49.0 Total 191.0</p>

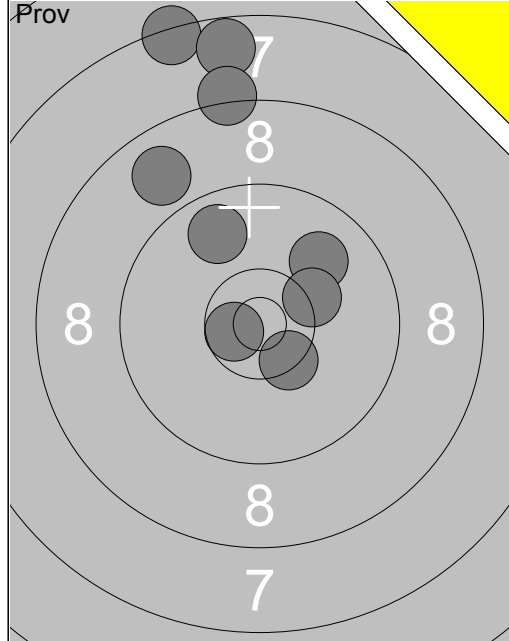

1:	9.9 ↗
2:	7.4 ↑
3:	7.7 ↑
4:	8.8 ↗
5:	8.2 ↑
6:	9.8 ↗
7:	10.4x ↘
8:	10.3 ↗
9:	10.6x ↘
Serie 78.0	
Total 0.0	

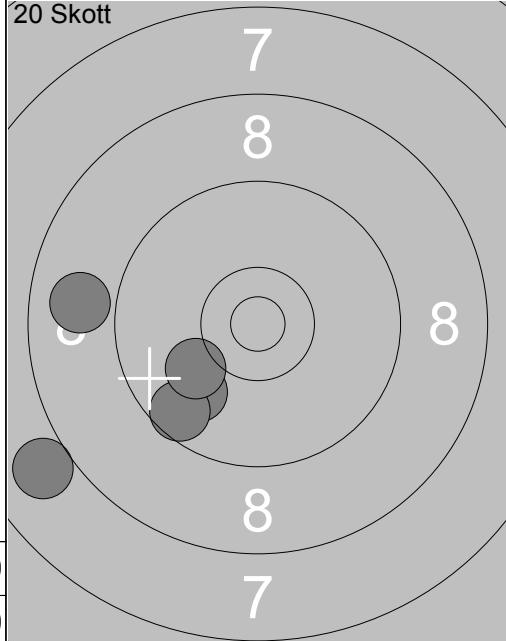

1:	8.9 ←
2:	9.9 ↘
3:	9.6 ↘
4:	10.1 ↘
5:	8.0 ↘
Serie 44.0	
Total 44.0	

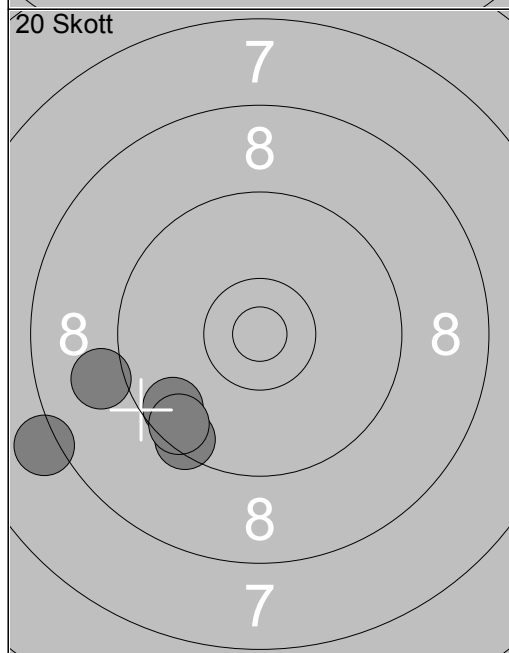

6:	9.0 ←
7:	8.1 ←
8:	9.5 ↘
9:	9.6 ↘
10:	9.5 ↘
Serie 44.0	
Total 88.0	

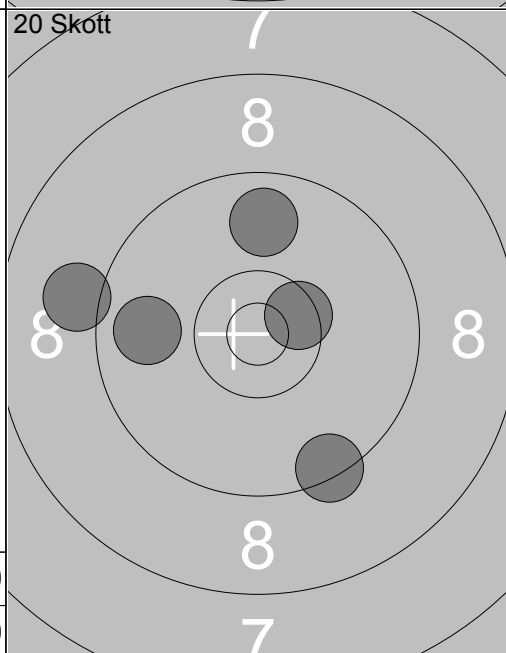

11:	9.8 ↑
12:	9.1 ←
13:	9.8 ←
14:	10.5x ↗
15:	9.4 ↘
Serie 46.0	
Total 134.0	

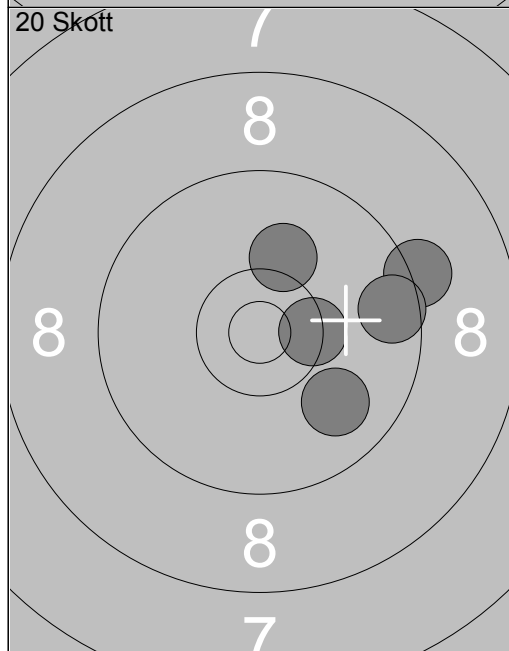

16:	9.2 ↗
17:	10.4x ↗
18:	9.6 →
19:	9.9 ↘
20:	10.2 ↑
Serie 47.0	
Total 181.0	

Skjuttag	Tavla	Dan-Ivan Karlsson			
3	1	Ramselefors		Vet-S	Vb
11.07.2017	Tavelträffen Korthåll 2017	Ramselefors SKF			
Prov		1: 7.4 ↘ 2: 9.4 → 3: 9.8 ↑ 4: 9.7 ↑ 5: 10.2 ← 6: 8.1 ↓ 7: 8.0 ← 8: 10.3x ← 9: 10.3x ↓ 10: 10.3x →	Prov		11: 10.6x ←
		Serie 90.0		Serie 10.0	
		Total 0.0		Total 0.0	
20 Skott		1: 10.7x ← 2: 9.5 ↓ 3: 10.0 → 4: 10.1 ← 5: 9.0 ←	20 Skott		6: 10.0 ↑ 7: 9.1 ↓ 8: 9.3 ↗ 9: 9.2 ↑ 10: 10.0 ←
		Serie 48.0		Serie 47.0	
		Total 48.0		Total 95.0	
20 Skott		11: 7.3 ↘ 12: 7.0 ← 13: 8.8 ← 14: 10.2 ← 15: 6.6 ↓	20 Skott		16: 10.7x ↘ 17: 8.1 → 18: 7.9 ↗ 19: 9.6 ↗ 20: 10.0 ↓
		Serie 38.0		Serie 44.0	
		Total 133.0		Total 177.0	

	<p>1: 9.5 →</p> <p>2: 10.7x→</p> <p>3: 9.1 ↓</p> <p>4: 9.4 ↘</p> <p>5: 9.0 ↓</p> <p>6: 10.2 ↑</p> <p>7: 8.9 ←</p> <p>8: 10.1 →</p> <p>9: 9.8 ↓</p> <p>10: 8.8 ↘</p>		<p>11: 9.6 ↓</p> <p>12: 10.7x↗</p> <p>13: 9.0 ↑</p> <p>14: 9.9 ↑</p> <p>15: 9.5 ↘</p>
Serie 91.0	Total 0.0	Serie 46.0	Total 0.0
	<p>1: 8.2 →</p> <p>2: 9.9 ↑</p> <p>3: 9.0 ↑</p> <p>4: 9.9 ←</p> <p>5: 9.7 ↓</p>		<p>6: 10.4x↘</p> <p>7: 10.3x↘</p> <p>8: 10.2 ↑</p> <p>9: 9.1 ←</p> <p>10: 10.7x↘</p>
Serie 44.0	Total 44.0	Serie 49.0	Total 93.0
	<p>11: 8.6 →</p> <p>12: 9.5 ↓</p> <p>13: 9.5 ←</p> <p>14: 8.9 ↗</p> <p>15: 7.6 →</p>		<p>16: 10.4x↘</p> <p>17: 6.4 ←</p> <p>18: 6.8 ←</p> <p>19: 9.5 ←</p> <p>20: 9.4 →</p>
Serie 41.0	Total 134.0	Serie 40.0	Total 174.0

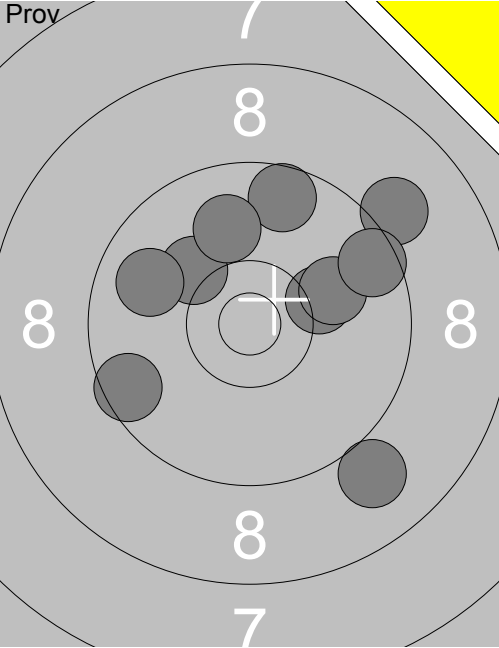
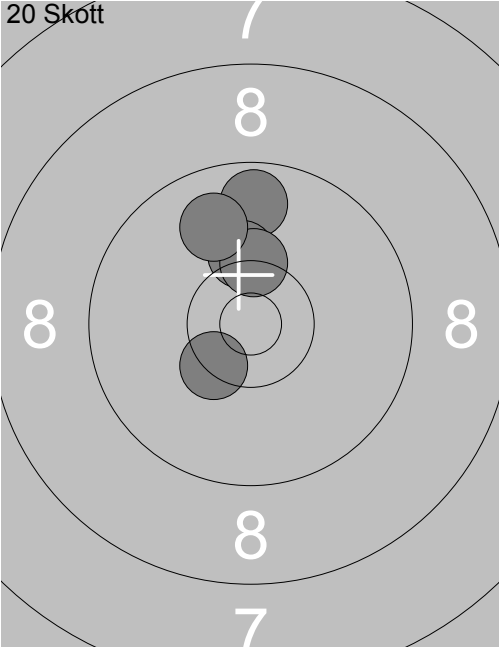
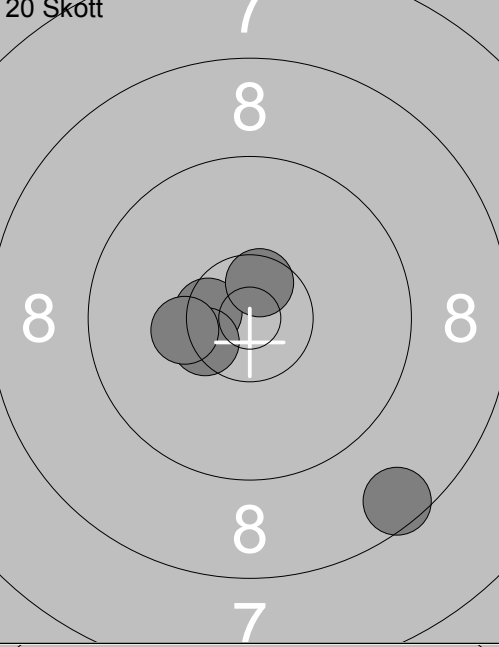
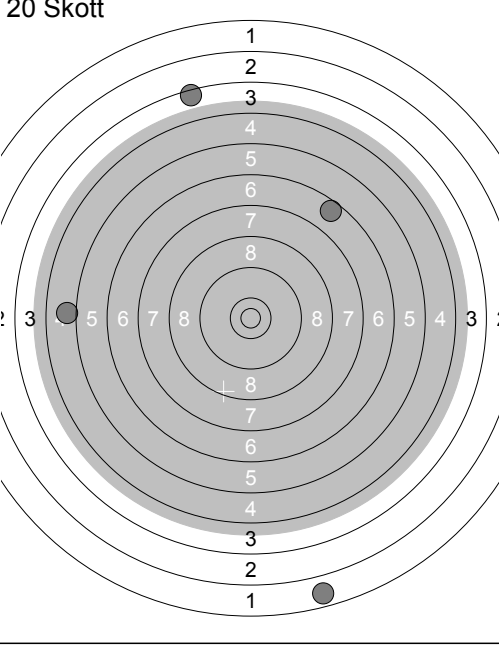
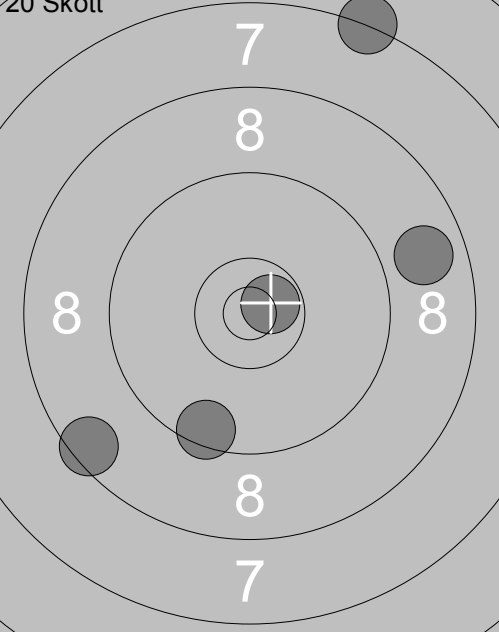
Skjutlag	Tavla	Christer Vredin			
3	4	Vindeln	Umeå	Sen-S	Vb
11.07.2017	Tavelträffen Korthåll 2017	Ramselefors SKF			
Prov 	1: 9.1 ↗ 2: 10.2 ↖ 3: 9.6 ↑ 4: 10.2 → 5: 9.8 ← 6: 10.0 → 7: 9.6 → 8: 9.5 ← 9: 9.0 ↓ 10: 10.0 ↑ Serie 94.0 Total 0.0	20 Skott 	1: 9.7 ↑ 2: 10.2 ↑ 3: 10.3x↑ 4: 9.9 ↑ 5: 10.4x↘ Serie 48.0 Total 48.0		
20 Skott 	6: 10.5x↙ 7: 8.6 ↓ 8: 10.4x↘ 9: 10.6x↑ 10: 10.3↙ Serie 48.0 Total 96.0	20 Skott 	11: 0.0 ↓ 12: 1.7 ↓ 13: 3.5 ↑ 14: 6.6 ↗ 15: 5.0 ← Serie 15.0 Total 111.0		
20 Skott 	16: 8.5 ↙ 17: 7.3 ↑ 18: 9.5 ↓ 19: 8.8 → 20: 10.7x↗ Serie 42.0 Total 153.0				

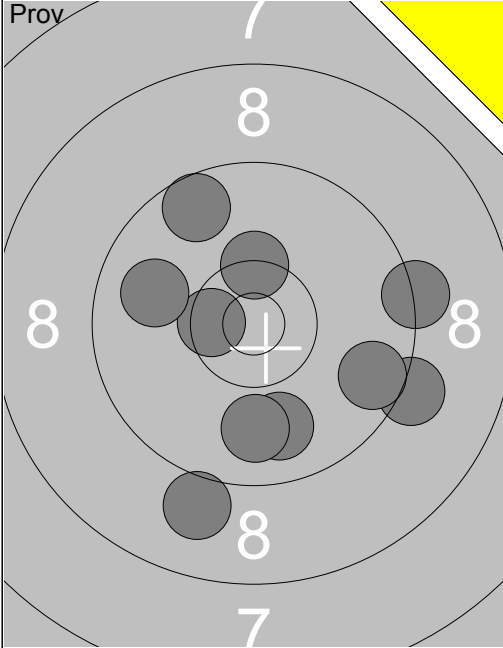
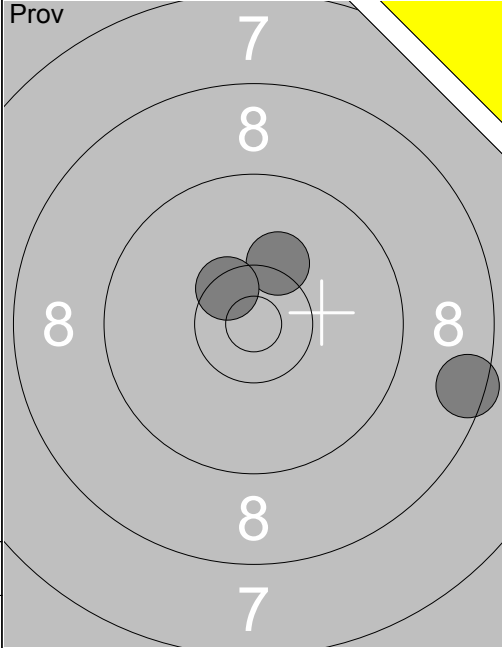
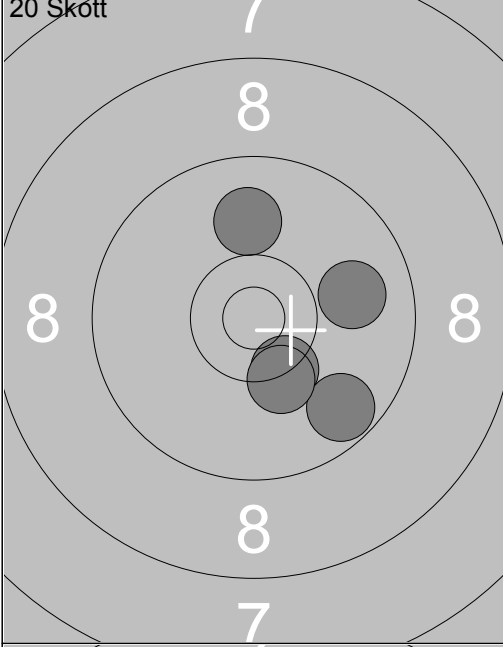
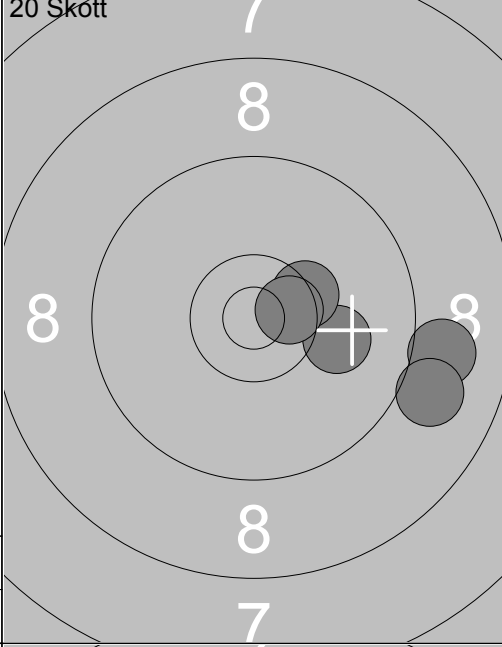
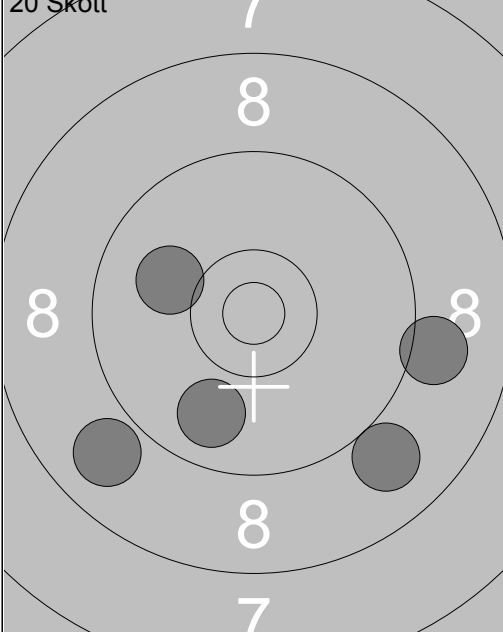
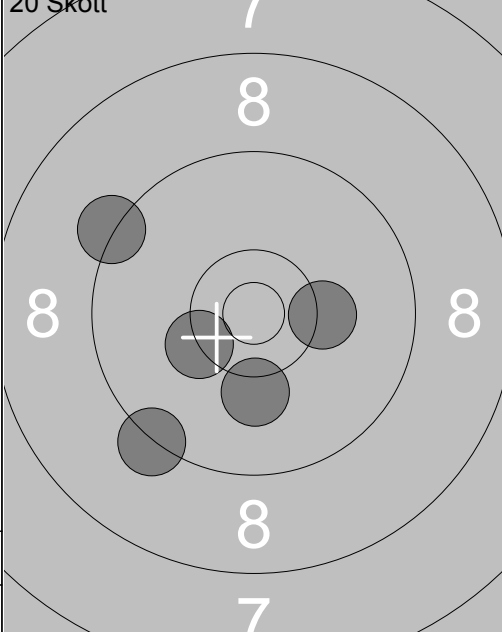
Skjuttag	Tavla	Donald Johansson			
3	5	Ale		Vet-S	No
11.07.2017	Tavelträffen Korthåll 2017	Ramselefors SKF			
Prov		1: 9.9 ↓ 2: 10.5x ← 3: 9.3 → 4: 9.2 → 5: 9.0 ↓ 6: 9.9 ← 7: 9.9 ↓ 8: 10.3x ↑ 9: 9.6 → 10: 9.6 ↗	Prov		11: 8.5 → 12: 10.2 ↗ 13: 10.5x ↘
		Serie 92.0		Serie 28.0	
		Total 0.0		Total 0.0	
20 Skott		1: 10.3x ↘ 2: 9.7 ↓ 3: 10.0 ↑ 4: 9.9 → 5: 10.3 ↓	20 Skott		6: 10.1 → 7: 9.0 → 8: 10.4x ↗ 9: 10.6x → 10: 9.0 →
		Serie 48.0		Serie 48.0	
		Total 48.0		Total 96.0	
20 Skott		11: 9.1 → 12: 9.0 ↓ 13: 9.8 ↓ 14: 10.0 ← 15: 8.9 ↘	20 Skott		16: 9.3 ↖ 17: 9.3 ↘ 18: 10.1 ↓ 19: 10.2 → 20: 10.3x ↘
		Serie 45.0		Serie 48.0	
		Total 141.0		Total 189.0	

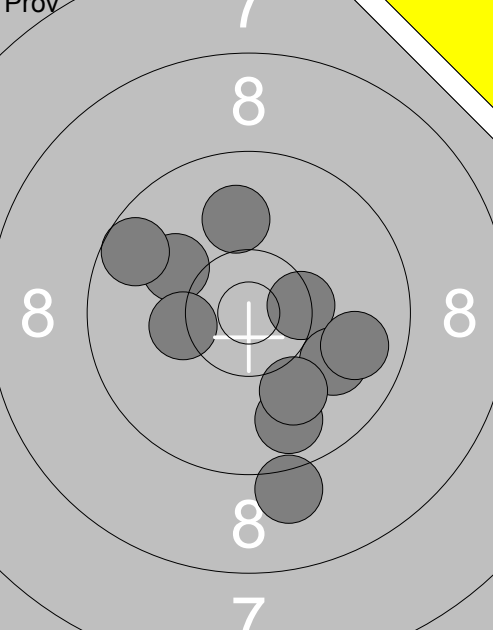
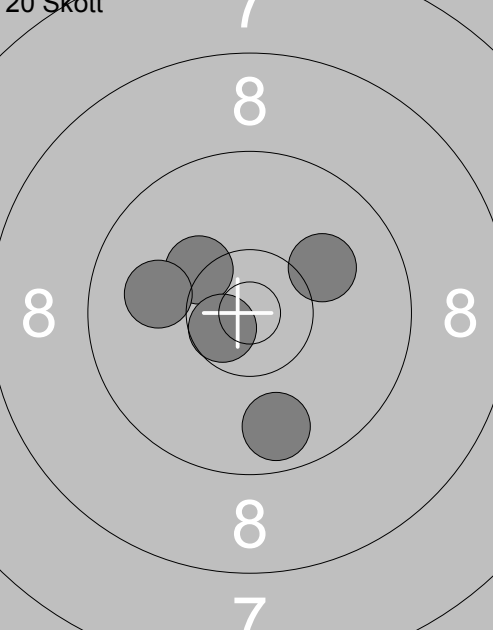
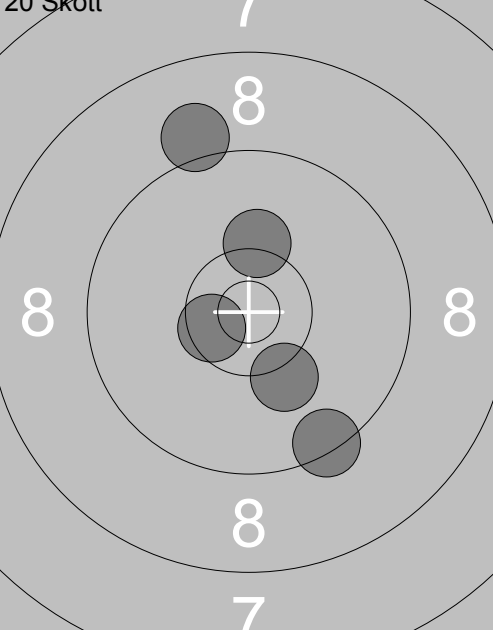
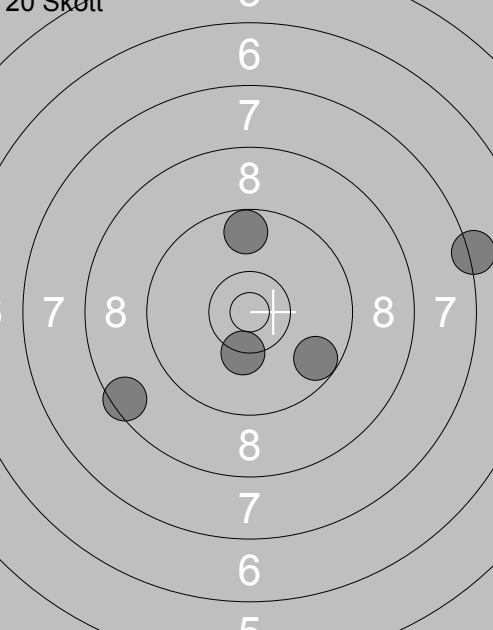
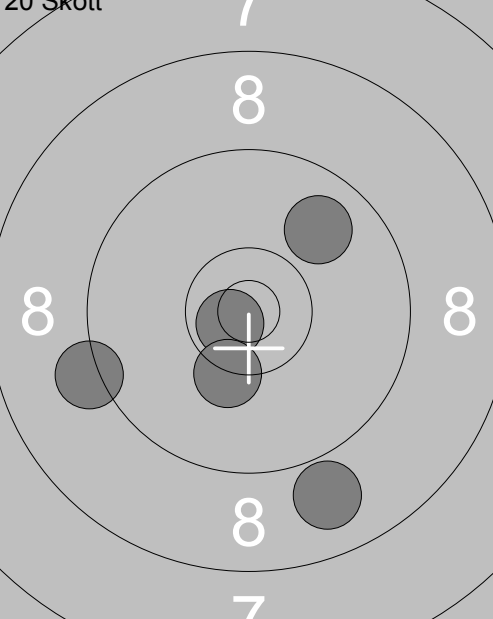
<div style="text-align: right; font-size: 0.8em; margin-bottom: 5px;">Prov</div> 	<div style="text-align: right; font-size: 0.8em; margin-bottom: 5px;">20 Skott</div> 	
<p>1: 10.1 ↖</p> <p>2: 10.4x →</p> <p>3: 10.0 ↑</p> <p>4: 9.8 ↓</p> <p>5: 9.6 ↖</p> <p>6: 9.1 ↓</p> <p>7: 10.0 ↘</p> <p>8: 10.3 ←</p> <p>9: 9.8 →</p> <p>10: 10.0 ↓</p>	<p>1: 10.3 ↖</p> <p>2: 10.0 ←</p> <p>3: 9.8 ↓</p> <p>4: 10.1 ↗</p> <p>5: 10.6x ↘</p>	
Serie 96.0	Serie 49.0	
Total 0.0	Total 49.0	
<div style="text-align: right; font-size: 0.8em; margin-bottom: 5px;">20 Skott</div> 	<div style="text-align: right; font-size: 0.8em; margin-bottom: 5px;">20 Skott</div> 	<div style="text-align: right; font-size: 0.8em; margin-bottom: 5px;">20 Skott</div> 
<p>6: 10.2 ↑</p> <p>7: 9.1 ↑</p> <p>8: 9.4 ↓</p> <p>9: 10.2 ↓</p> <p>10: 10.5x ↘</p>	<p>11: 8.5 ↙</p> <p>12: 9.7 ↑</p> <p>13: 10.3 ↓</p> <p>14: 7.2 →</p> <p>15: 9.7 ↘</p>	<p>16: 8.9 ↓</p> <p>17: 9.9 ↗</p> <p>18: 10.7x ↘</p> <p>19: 9.2 ←</p> <p>20: 10.3 ↓</p>
Serie 48.0	Serie 43.0	Serie 46.0
Total 97.0	Total 140.0	Total 186.0

	<table border="1" style="width:100%; border-collapse: collapse;"> <tr><td>1:</td><td>7.0</td><td>↑</td></tr> <tr><td>2:</td><td>5.2</td><td>↑</td></tr> <tr><td>3:</td><td>7.5</td><td>↑</td></tr> <tr><td>4:</td><td>7.3</td><td>↗</td></tr> <tr><td>5:</td><td>7.4</td><td>↑</td></tr> <tr><td>6:</td><td>8.3</td><td>↗</td></tr> <tr><td>7:</td><td>6.5</td><td>↗</td></tr> <tr><td>8:</td><td>8.5</td><td>↑</td></tr> <tr><td>9:</td><td>9.7</td><td>↓</td></tr> <tr><td>10:</td><td>10.5x</td><td>↗</td></tr> <tr><td colspan="2">Serie</td><td>74.0</td></tr> <tr><td colspan="2">Total</td><td>0.0</td></tr> </table>	1:	7.0	↑	2:	5.2	↑	3:	7.5	↑	4:	7.3	↗	5:	7.4	↑	6:	8.3	↗	7:	6.5	↗	8:	8.5	↑	9:	9.7	↓	10:	10.5x	↗	Serie		74.0	Total		0.0		<table border="1" style="width:100%; border-collapse: collapse;"> <tr><td>11:</td><td>8.7</td><td>↙</td></tr> <tr><td>12:</td><td>10.2</td><td>↗</td></tr> <tr><td>13:</td><td>9.9</td><td>↗</td></tr> <tr><td>14:</td><td>7.8</td><td>↖</td></tr> <tr><td>15:</td><td>9.0</td><td>↖</td></tr> <tr><td>16:</td><td>8.7</td><td>↗</td></tr> <tr><td>17:</td><td>10.2</td><td>→</td></tr> <tr><td>18:</td><td>10.0</td><td>↖</td></tr> <tr><td>19:</td><td>9.1</td><td>→</td></tr> <tr><td>20:</td><td>9.7</td><td>↖</td></tr> <tr><td colspan="2">Serie</td><td>89.0</td></tr> <tr><td colspan="2">Total</td><td>0.0</td></tr> </table>	11:	8.7	↙	12:	10.2	↗	13:	9.9	↗	14:	7.8	↖	15:	9.0	↖	16:	8.7	↗	17:	10.2	→	18:	10.0	↖	19:	9.1	→	20:	9.7	↖	Serie		89.0	Total		0.0
1:	7.0	↑																																																																									
2:	5.2	↑																																																																									
3:	7.5	↑																																																																									
4:	7.3	↗																																																																									
5:	7.4	↑																																																																									
6:	8.3	↗																																																																									
7:	6.5	↗																																																																									
8:	8.5	↑																																																																									
9:	9.7	↓																																																																									
10:	10.5x	↗																																																																									
Serie		74.0																																																																									
Total		0.0																																																																									
11:	8.7	↙																																																																									
12:	10.2	↗																																																																									
13:	9.9	↗																																																																									
14:	7.8	↖																																																																									
15:	9.0	↖																																																																									
16:	8.7	↗																																																																									
17:	10.2	→																																																																									
18:	10.0	↖																																																																									
19:	9.1	→																																																																									
20:	9.7	↖																																																																									
Serie		89.0																																																																									
Total		0.0																																																																									

	<table border="1" style="width:100%; border-collapse: collapse;"> <tr><td>21:</td><td>9.5</td><td>↑</td></tr> <tr><td>22:</td><td>9.5</td><td>↗</td></tr> <tr><td>23:</td><td>10.4x</td><td>↖</td></tr> <tr><td>24:</td><td>9.3</td><td>↗</td></tr> <tr><td>25:</td><td>9.5</td><td>↗</td></tr> <tr><td>26:</td><td>7.0</td><td>↗</td></tr> <tr><td colspan="2">Serie</td><td>53.0</td></tr> <tr><td colspan="2">Total</td><td>0.0</td></tr> </table>	21:	9.5	↑	22:	9.5	↗	23:	10.4x	↖	24:	9.3	↗	25:	9.5	↗	26:	7.0	↗	Serie		53.0	Total		0.0		<table border="1" style="width:100%; border-collapse: collapse;"> <tr><td>1:</td><td>8.8</td><td>↘</td></tr> <tr><td>2:</td><td>10.2</td><td>→</td></tr> <tr><td>3:</td><td>10.5x</td><td>↗</td></tr> <tr><td>4:</td><td>8.4</td><td>↗</td></tr> <tr><td>5:</td><td>7.7</td><td>↗</td></tr> <tr><td colspan="2">Serie</td><td>43.0</td></tr> <tr><td colspan="2">Total</td><td>43.0</td></tr> </table>	1:	8.8	↘	2:	10.2	→	3:	10.5x	↗	4:	8.4	↗	5:	7.7	↗	Serie		43.0	Total		43.0
21:	9.5	↑																																														
22:	9.5	↗																																														
23:	10.4x	↖																																														
24:	9.3	↗																																														
25:	9.5	↗																																														
26:	7.0	↗																																														
Serie		53.0																																														
Total		0.0																																														
1:	8.8	↘																																														
2:	10.2	→																																														
3:	10.5x	↗																																														
4:	8.4	↗																																														
5:	7.7	↗																																														
Serie		43.0																																														
Total		43.0																																														

	<table border="1" style="width:100%; border-collapse: collapse;"> <tr><td>6:</td><td>9.1</td><td>↖</td></tr> <tr><td>7:</td><td>9.1</td><td>→</td></tr> <tr><td>8:</td><td>8.6</td><td>↑</td></tr> <tr><td>9:</td><td>9.2</td><td>↗</td></tr> <tr><td>10:</td><td>9.9</td><td>↗</td></tr> <tr><td colspan="2">Serie</td><td>44.0</td></tr> <tr><td colspan="2">Total</td><td>87.0</td></tr> </table>	6:	9.1	↖	7:	9.1	→	8:	8.6	↑	9:	9.2	↗	10:	9.9	↗	Serie		44.0	Total		87.0		<table border="1" style="width:100%; border-collapse: collapse;"> <tr><td>11:</td><td>8.9</td><td>↗</td></tr> <tr><td>12:</td><td>8.3</td><td>↖</td></tr> <tr><td>13:</td><td>7.5</td><td>↗</td></tr> <tr><td>14:</td><td>5.0</td><td>↖</td></tr> <tr><td>15:</td><td>6.8</td><td>↖</td></tr> <tr><td colspan="2">Serie</td><td>34.0</td></tr> <tr><td colspan="2">Total</td><td>121.0</td></tr> </table>	11:	8.9	↗	12:	8.3	↖	13:	7.5	↗	14:	5.0	↖	15:	6.8	↖	Serie		34.0	Total		121.0
6:	9.1	↖																																											
7:	9.1	→																																											
8:	8.6	↑																																											
9:	9.2	↗																																											
10:	9.9	↗																																											
Serie		44.0																																											
Total		87.0																																											
11:	8.9	↗																																											
12:	8.3	↖																																											
13:	7.5	↗																																											
14:	5.0	↖																																											
15:	6.8	↖																																											
Serie		34.0																																											
Total		121.0																																											

	<table border="1" style="width:100%; border-collapse: collapse;"> <tr><td>16:</td><td>9.1</td><td>→</td></tr> <tr><td>17:</td><td>7.1</td><td>↗</td></tr> <tr><td>18:</td><td>9.4</td><td>↘</td></tr> <tr><td>19:</td><td>10.0</td><td>↖</td></tr> <tr><td>20:</td><td>9.3</td><td>↖</td></tr> <tr><td colspan="2">Serie</td><td>44.0</td></tr> <tr><td colspan="2">Total</td><td>165.0</td></tr> </table>	16:	9.1	→	17:	7.1	↗	18:	9.4	↘	19:	10.0	↖	20:	9.3	↖	Serie		44.0	Total		165.0		
16:	9.1	→																						
17:	7.1	↗																						
18:	9.4	↘																						
19:	10.0	↖																						
20:	9.3	↖																						
Serie		44.0																						
Total		165.0																						

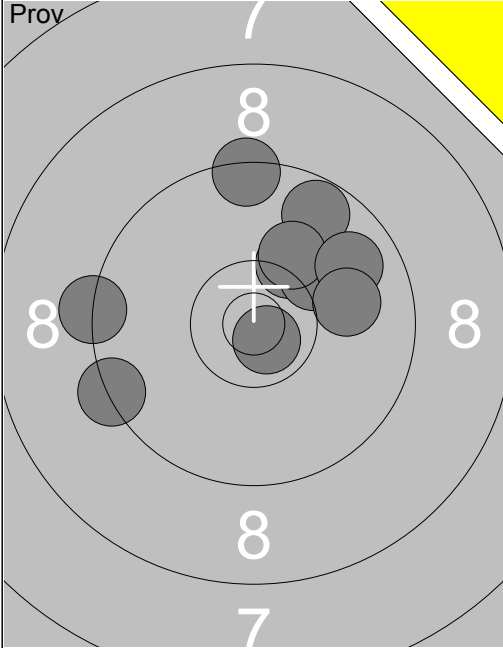
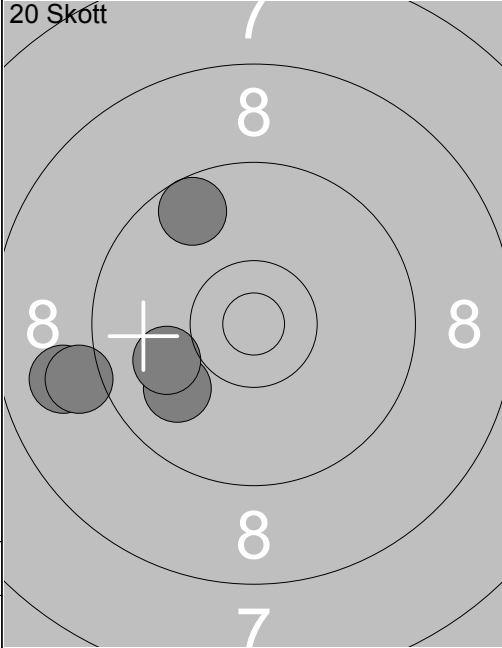
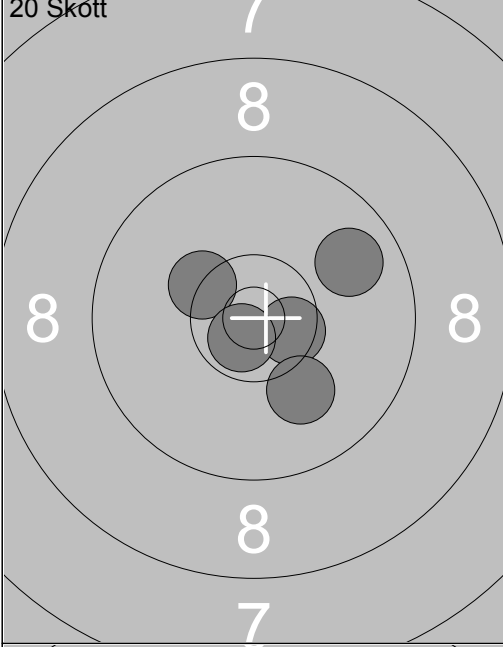
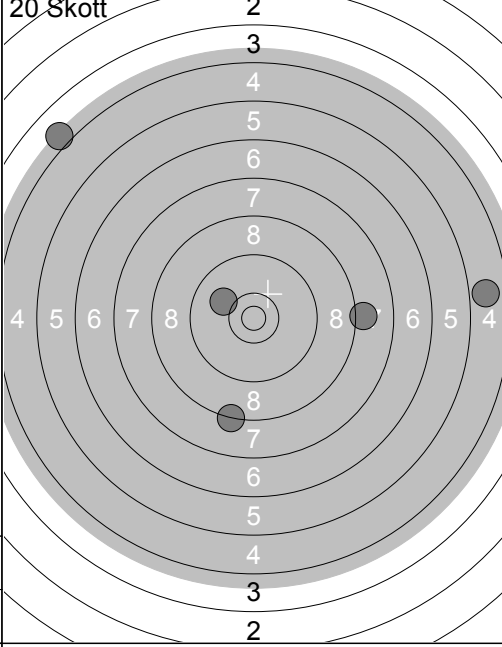
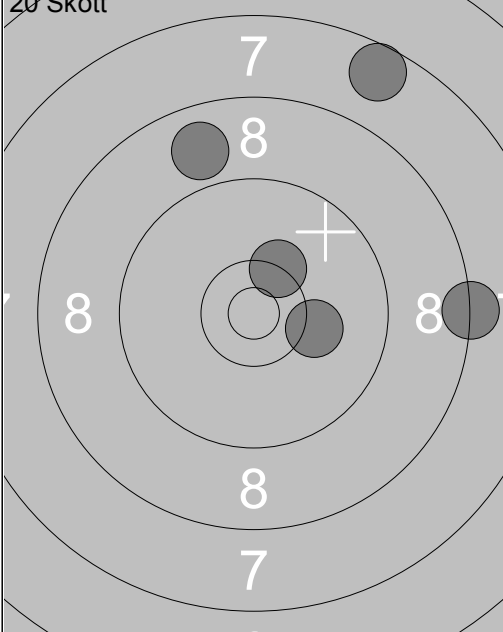
Skjutlag	Tavla	Emma Wallerström			
3	9	Vindeln	Umeå	Jun-S	Vb
11.07.2017		Tavelträffen Korthåll 2017		Ramselefors SKF	
Prov		1: 10.2 ↗	20 Skott		1: 9.9 ↙
		2: 9.4 ↑			2: 8.9 ←
		3: 10.2 ↗			3: 10.0 ←
		4: 9.7 ↗			4: 9.6 ↗
		5: 10.1 ↗			5: 9.1 ←
		6: 9.3 ←			
		7: 9.3 ←			
		8: 9.8 ↗			
		9: 10.7x ↘			
		10: 10.0 →			
		Serie 95.0			Serie 45.0
		Total 0.0			Total 45.0
20 Skott		6: 10.3x ↘	20 Skott		11: 4.9 →
		7: 9.8 ↗			12: 10.0 ↙
		8: 10.5x →			13: 4.0 ↗
		9: 10.7x ↘			14: 8.1 →
		10: 10.1 ↘			15: 8.3 ↓
		Serie 49.0			Serie 34.0
		Total 94.0			Total 128.0
20 Skott		16: 8.8 ↑			
		17: 8.3 →			
		18: 7.6 ↗			
		19: 10.3x ↗			
		20: 10.2 →			
		Serie 43.0			
		Total 171.0			

<p>Prov</p> <p>1: 9.6 ➔ 2: 9.2 ↗ 3: 9.7 ↘ 4: 9.3 ↗ 5: 9.2 ↗ 6: 10.3x ➔ 7: 10.2 ↑ 8: 10.2 ↑ 9: 8.5 ↗ 10: 9.9 ↗</p> <p>Serie 92.0 Total 0.0</p>	<p>Prov</p> <p>11: 9.4 ← 12: 10.0 ↘</p> <p>Serie 19.0 Total 0.0</p>
<p>20 Skott</p> <p>1: 10.6x ↗ 2: 8.5 ↘ 3: 10.1 ↘ 4: 10.1 ← 5: 10.2 ↘</p> <p>Serie 48.0 Total 48.0</p>	<p>20 Skott</p> <p>6: 9.4 ↘ 7: 10.7x ↗ 8: 7.4 ↘ 9: 10.2 ↑ 10: 9.1 ↗</p> <p>Serie 45.0 Total 93.0</p>
<p>20 Skott</p> <p>11: 8.6 ↑ 12: 7.8 ➔ 13: 7.8 ➔ 14: 10.7x ↘ 15: 4.9 ↘</p> <p>Serie 36.0 Total 129.0</p>	<p>20 Skott</p> <p>16: 6.3 ➔ 17: 10.2 ↑ 18: 9.7 ↗ 19: 10.6x ➔ 20: 8.9 ➔</p> <p>Serie 43.0 Total 172.0</p>

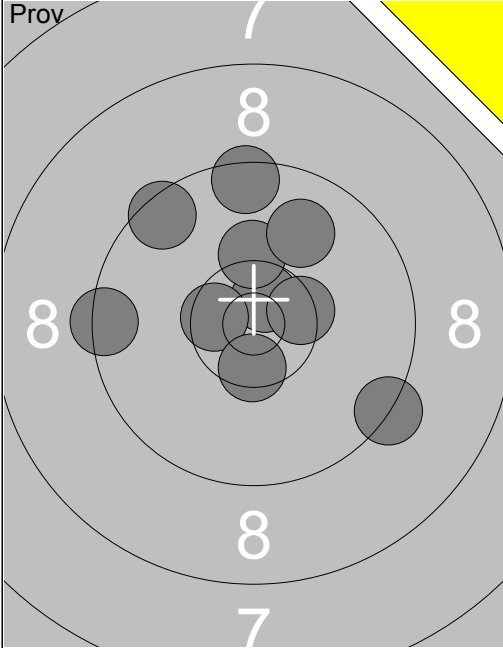
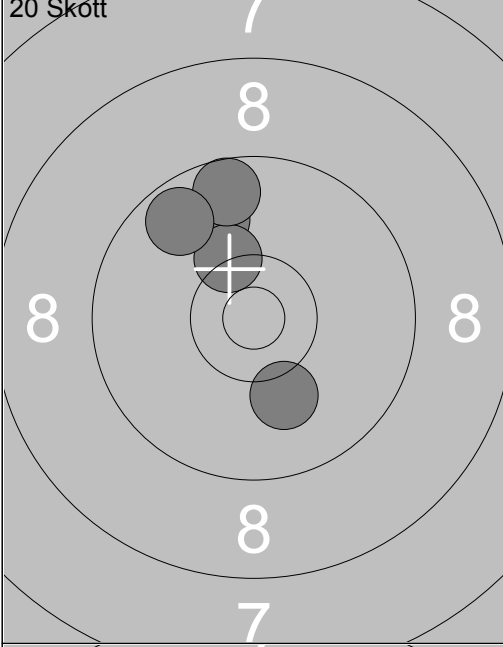
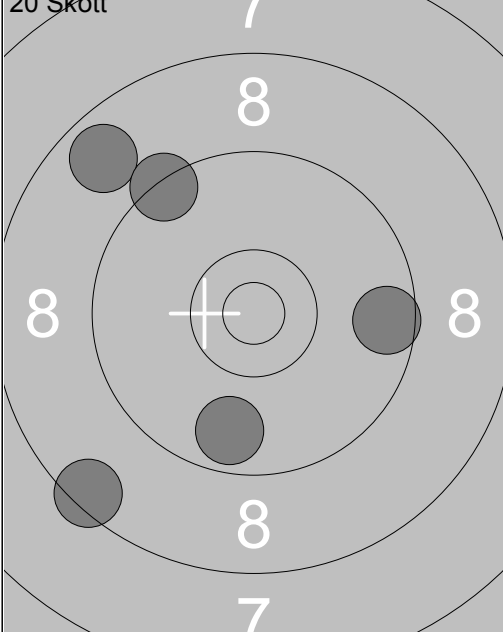
Skjuttag	Tavla	Hans Bakken	
3	11		
Vindeln	Nordre Skage (NOR)		Sen-S
11.07.2017	Tavelträffen Korthåll 2017	Ramselefors SKF	
Prov		1: 10.7x ↗ 2: 10.2 ↑ 3: 9.4 ← 4: 9.3 ↘ 5: 10.5x ← 6: 9.5 ↖ 7: 9.9 ↗ 8: 9.5 ↑ 9: 10.5x ↓ 10: 10.5x →	11: 9.9 ← 12: 9.5 ↖ 13: 10.0 ↑ 14: 10.0 ↓ 15: 10.1 ←
		Serie 95.0	Serie 48.0
		Total 0.0	Total 0.0
20 Skott		1: 9.9 ↑ 2: 10.3x ↗ 3: 9.6 ↑ 4: 9.7 ↖ 5: 10.1 ↓	6: 9.3 → 7: 10.6x ↘ 8: 10.4x ↗ 9: 10.5x ↓ 10: 10.1 ↑
		Serie 47.0	Serie 49.0
		Total 47.0	Total 96.0
20 Skott		11: 8.7 ↖ 12: 9.7 ↓ 13: 9.4 ↖ 14: 9.6 → 15: 8.5 ↙	16: 10.2 ↗ 17: 10.7x ↘ 18: 9.7 ↑ 19: 8.5 ↓ 20: 10.8x ↓
		Serie 43.0	Serie 47.0
		Total 139.0	Total 186.0

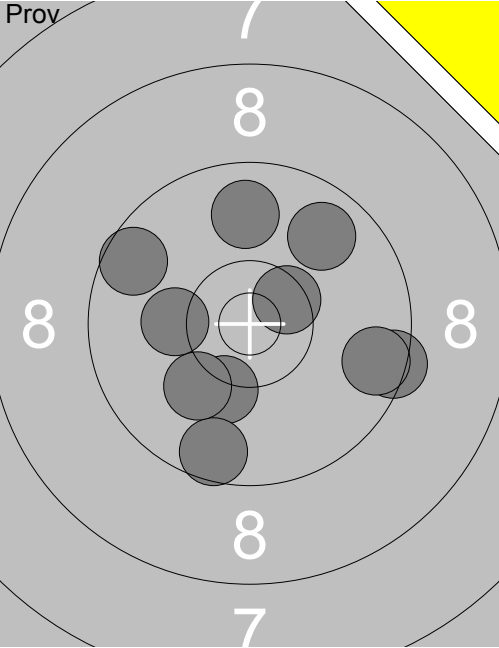
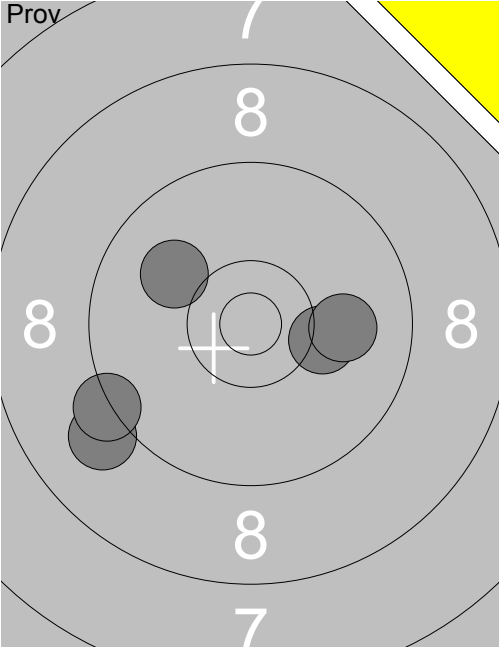
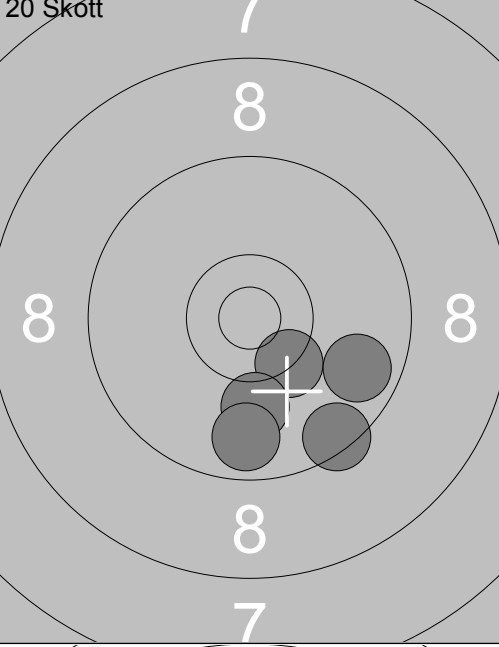
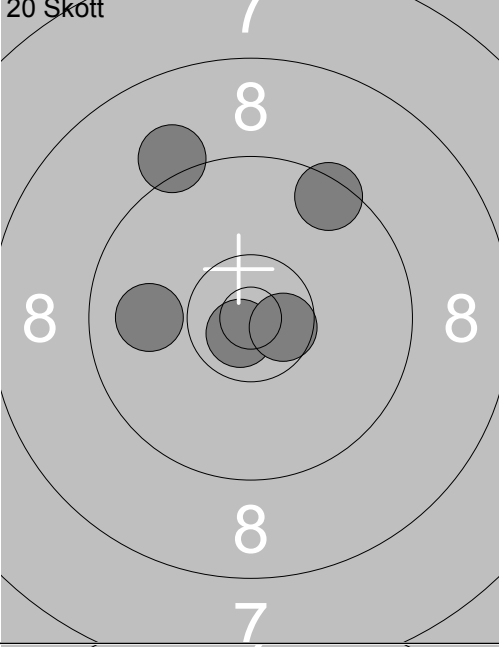
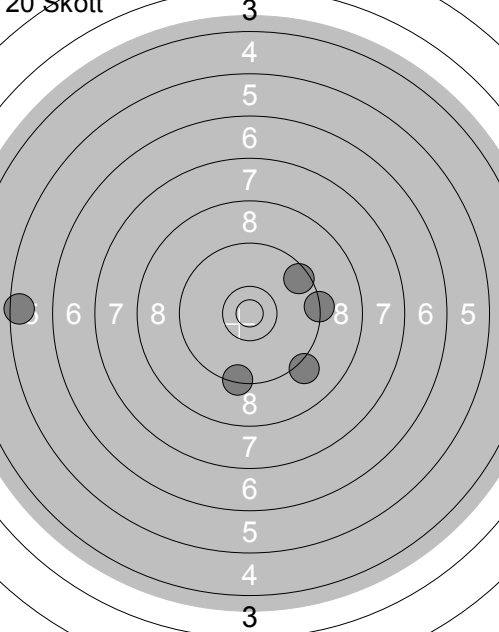
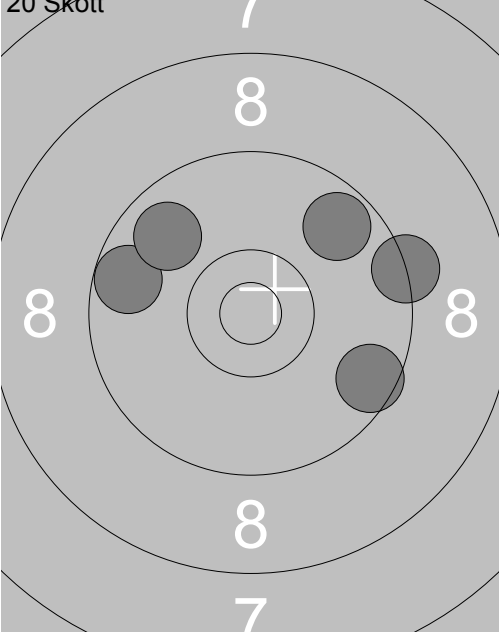

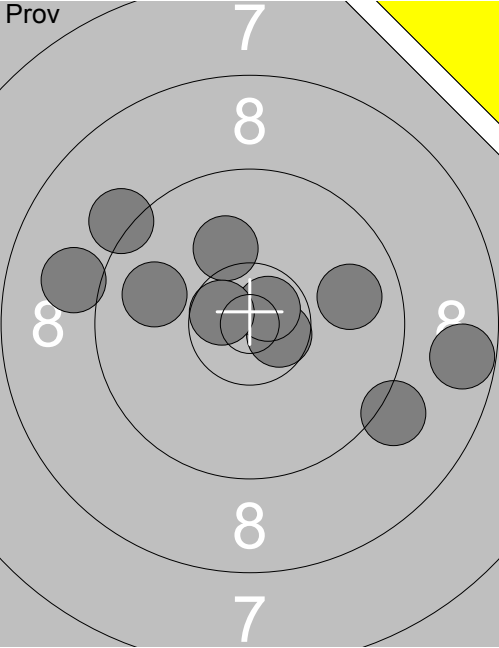
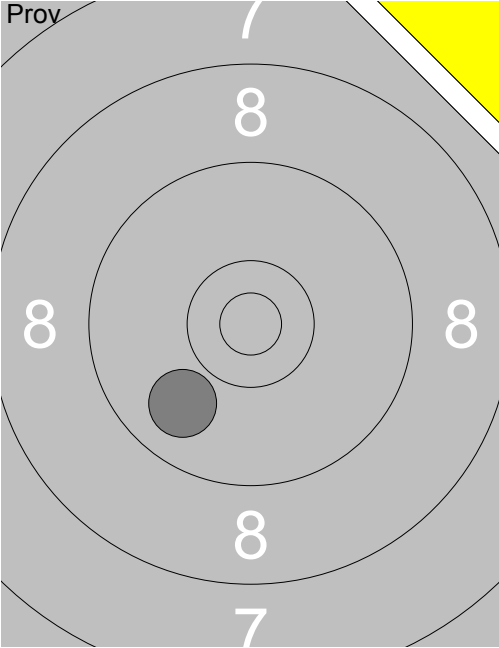
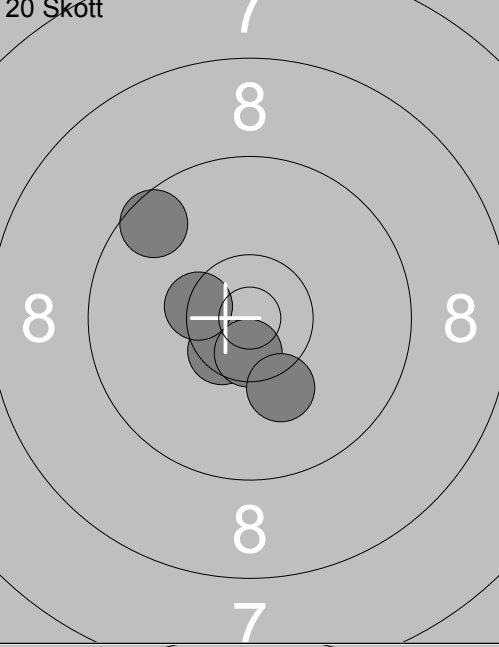
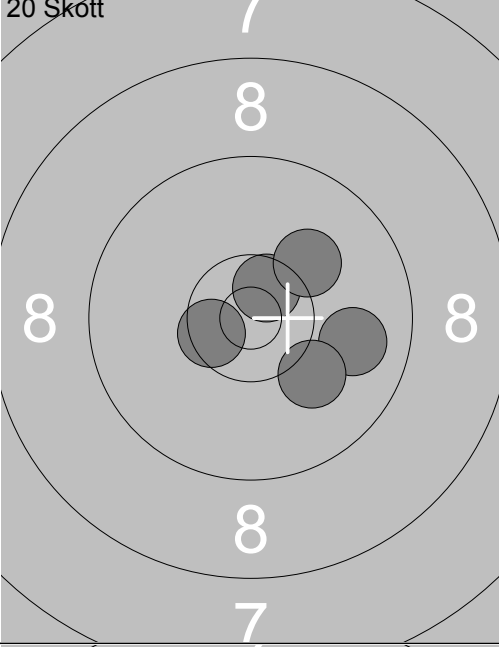
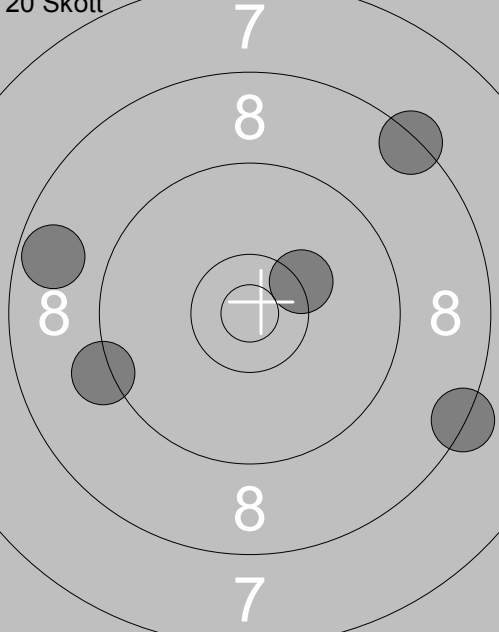
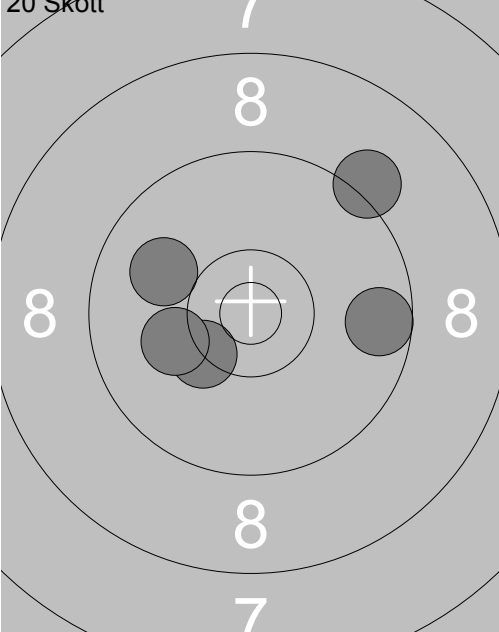
Skjutlag	Tavla	Henry Lindström			
3	12	Vindeln	I 19 / A 9	Vet-S	No
11.07.2017	Tavelträffen Korthåll 2017	Ramselefors SKF			
Prov		1: 10.5x ↗ 2: 10.2 ↓ 3: 9.4 → 4: 9.6 ↓ 5: 9.6 ← 6: 9.6 → 7: 10.1 ↓ 8: 9.8 ↑ 9: 9.8 ↗ 10: 10.2 ←	Prov		11: 10.2 → 12: 10.0 → 13: 9.1 ↙ 14: 9.3 ↙ 15: 10.0 ↖
		Serie 94.0		Serie 48.0	
		Total 0.0		Total 0.0	
20 Skott		1: 9.4 ↓ 2: 10.3x ↘ 3: 10.0 ↓ 4: 9.7 ↓ 5: 9.7 →	20 Skott		6: 9.1 ↖ 7: 10.8x ↘ 8: 9.9 ← 9: 9.5 ↗ 10: 10.6x →
		Serie 47.0		Serie 47.0	
		Total 47.0		Total 94.0	
20 Skott		11: 9.1 ↓ 12: 9.4 ↓ 13: 9.5 ↗ 14: 5.5 ← 15: 9.3 →	20 Skott		16: 9.7 ← 17: 9.7 ↗ 18: 9.8 ↖ 19: 9.6 → 20: 9.3 →
		Serie 41.0		Serie 45.0	
		Total 135.0		Total 180.0	

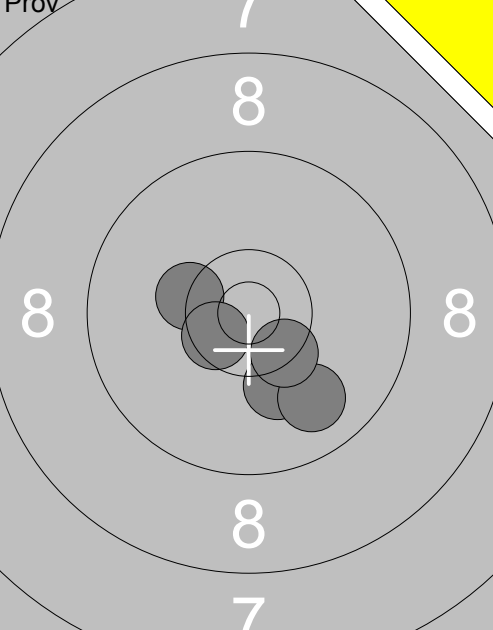
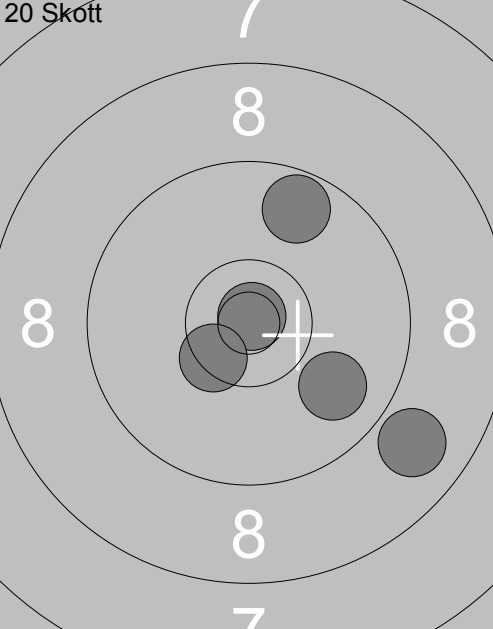
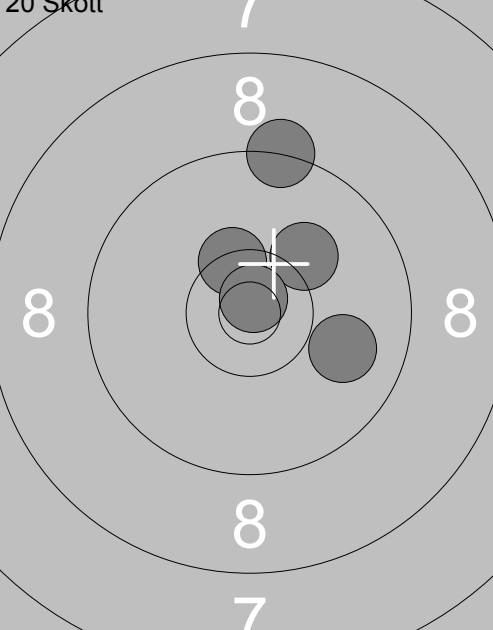
Skjuttag	Tavla	Hilde Karlsson			
3	13	Ramselefors		Sen-S	Vb
11.07.2017	Tavelträffen Korthåll 2017	Ramselefors SKF			
Prov		1: 8.7 → 2: 9.1 ↘ 3: 10.6x↘ 4: 9.0 ← 5: 9.2 ↖ 6: 10.7x↗ 7: 9.8 → 8: 10.1 ↑ 9: 9.9 ← 10: 10.6x↖	Prov		11: 9.9 ↙
		Serie 93.0		Serie 9.0	
		Total 0.0		Total 0.0	
20 Skott		1: 10.5x↘ 2: 10.6x↓ 3: 10.2 ↓ 4: 10.4x↖ 5: 9.6 ↖	20 Skott		6: 10.5x↖ 7: 9.9 → 8: 10.6x↗ 9: 10.1 ↗ 10: 10.1 ↘
		Serie 49.0		Serie 49.0	
		Total 49.0		Total 98.0	
20 Skott		11: 8.7 ← 12: 10.3x↗ 13: 8.4 ↗ 14: 8.3 → 15: 9.2 ←	20 Skott		16: 9.2 ↗ 17: 10.3x↖ 18: 10.1 ← 19: 10.0 ↖ 20: 9.6 →
		Serie 43.0		Serie 48.0	
		Total 141.0		Total 189.0	

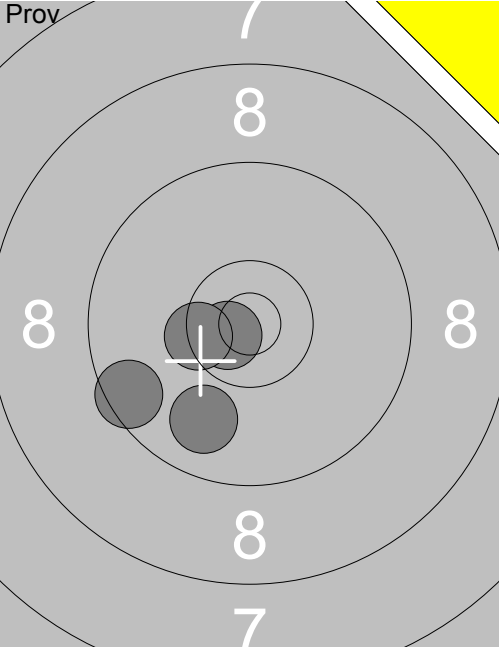
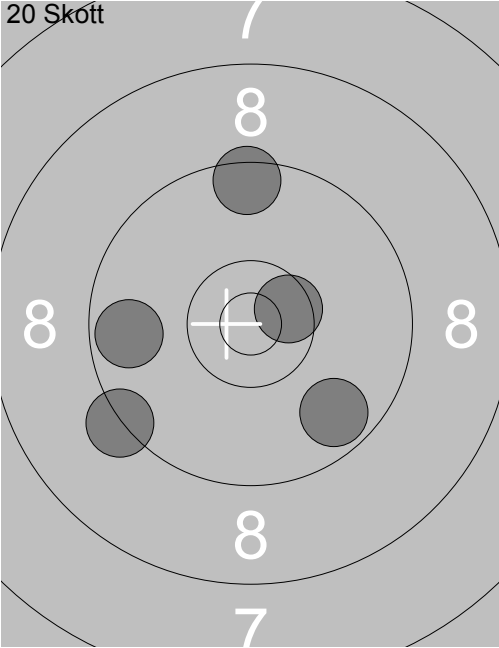
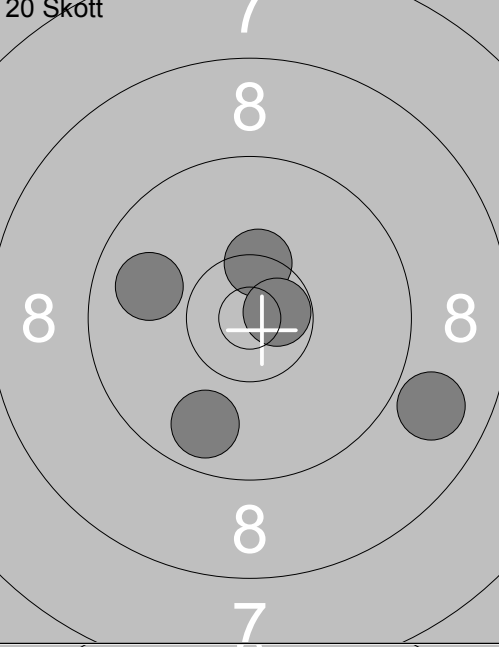
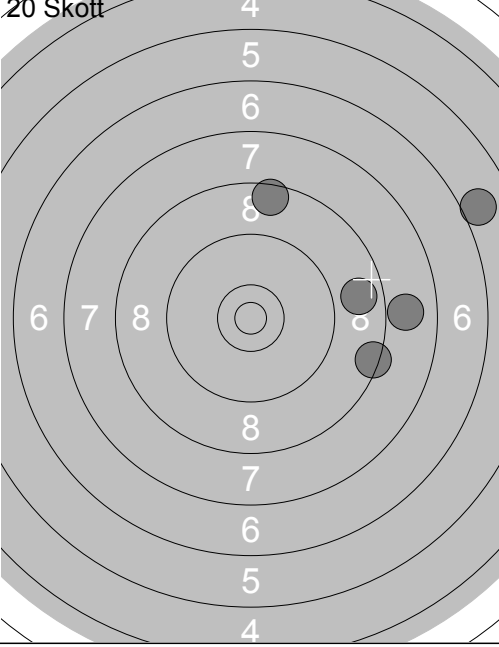
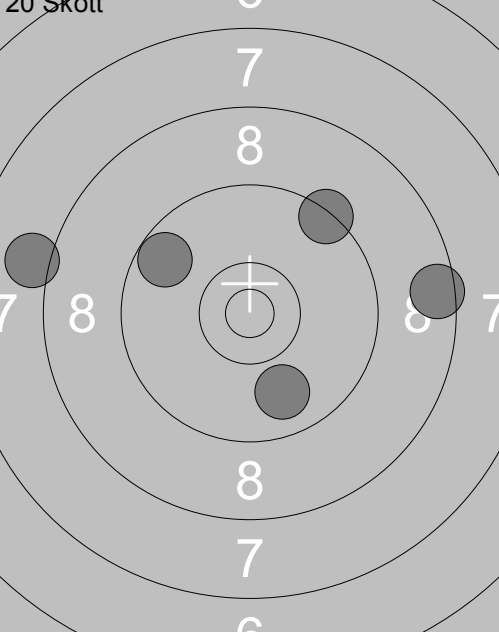
<div style="text-align: right; font-size: 0.8em;">Prov</div>  <div style="text-align: center; font-size: 1.5em; font-weight: bold;">8</div>	<div style="text-align: right; font-size: 0.8em;">20 Skott</div>  <div style="text-align: center; font-size: 1.5em; font-weight: bold;">8</div>	<div style="text-align: right; font-size: 0.8em;">20 Skott</div>  <div style="text-align: center; font-size: 1.5em; font-weight: bold;">8</div>
<p>1: 10.2 ↘</p> <p>2: 9.9 ↘</p> <p>3: 10.4x↘</p> <p>4: 10.3x↘</p> <p>5: 10.5x↘</p>	<p>6: 9.7 ↗</p> <p>7: 9.9 ↘</p> <p>8: 8.9 ↘</p> <p>9: 10.9x↗</p> <p>10: 10.4x↘</p>	<p>1: 10.4x↗</p> <p>2: 10.2 ↗</p> <p>3: 10.8x↗</p> <p>4: 9.9 →</p> <p>5: 9.3 ↑</p>
Serie 49.0	Serie 46.0	Serie 48.0
Total 0.0	Total 94.0	Total 48.0
<div style="text-align: right; font-size: 0.8em;">20 Skott</div>  <div style="text-align: center; font-size: 1.5em; font-weight: bold;">8</div>	<p>11: 8.9 ↘</p> <p>12: 8.7 ↘</p> <p>13: 8.9 ↘</p> <p>14: 8.2 →</p> <p>15: 7.5 ↗</p>	<p>16: 9.3 ↖</p> <p>17: 10.4x↘</p> <p>18: 9.5 →</p> <p>19: 10.1←</p> <p>20: 9.7 ↖</p>
Serie 47.0	Serie 39.0	Serie 39.0
Total 180.0	Total 133.0	Total 133.0

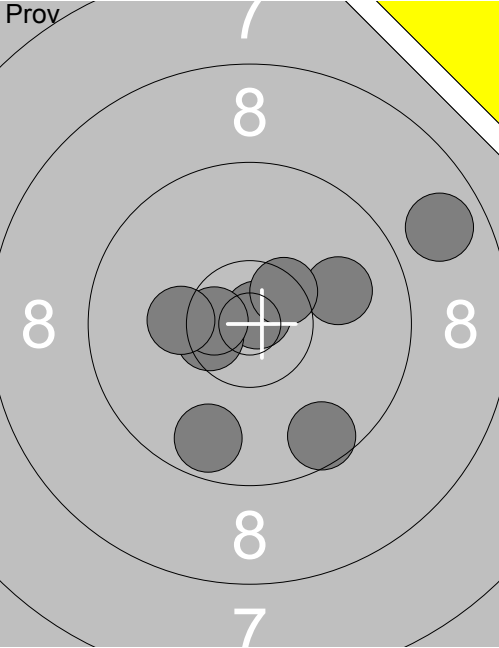
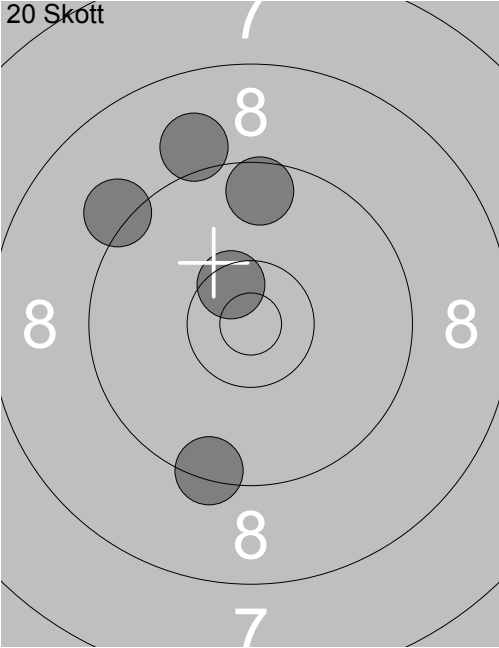
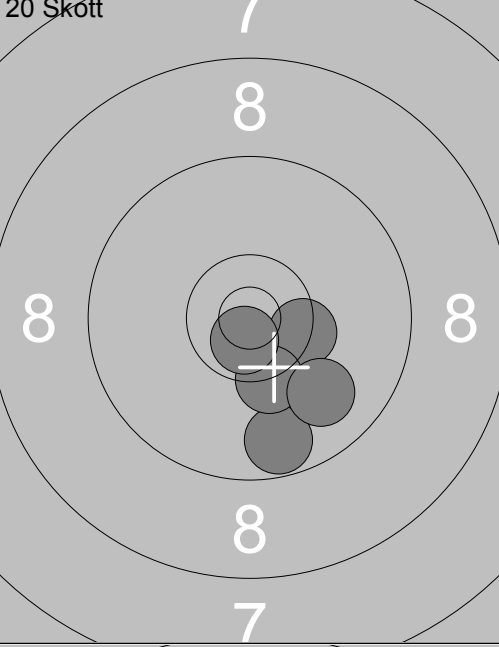
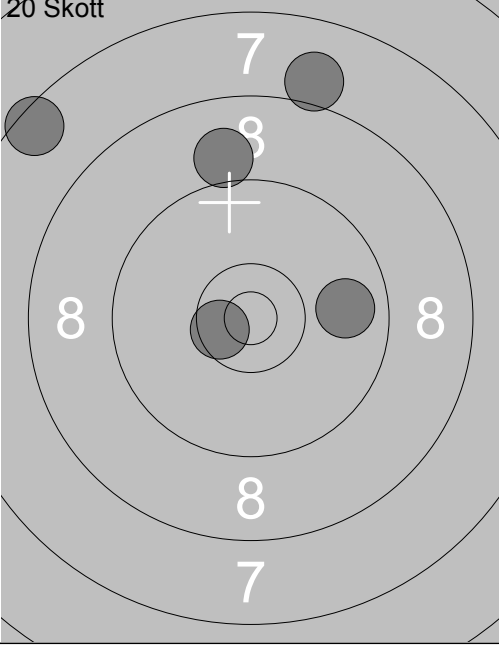
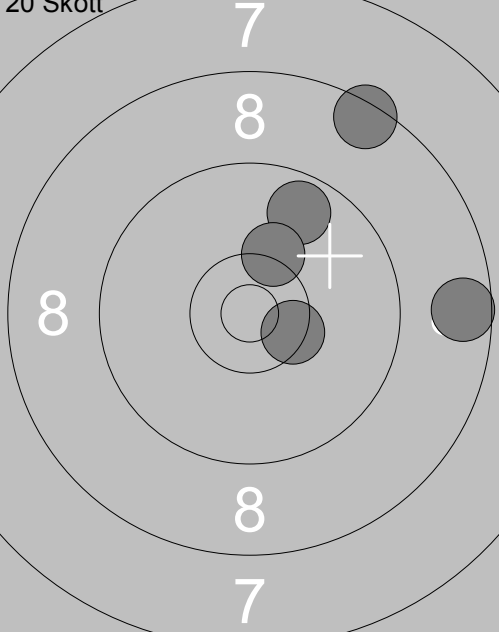
Skjuttag	Tavla	Johan Nilsson			
3	15	Vindeln	Ramselefors	Sen-S	Vb
11.07.2017	Tavelträffen Korthåll 2017	Ramselefors SKF			
Prov		1: 9.5 ↙ 2: 9.9 ↓ 3: 10.7x↙ 4: 10.4x↙	20 Skött		1: 9.7 ↘ 2: 9.5 ↑ 3: 9.7 ← 4: 10.5x➤ 5: 9.3 ↙
		Serie 38.0		Serie 46.0	
		Total 0.0		Total 46.0	
20 Skött		6: 9.9 ← 7: 8.9 ➤ 8: 9.8 ↓ 9: 10.4x↑ 10: 10.7x➤	20 Skött		11: 8.6 ↑ 12: 6.0 ➤ 13: 8.8 ➤ 14: 8.4 ➤ 15: 7.9 ➤
		Serie 46.0		Serie 37.0	
		Total 92.0		Total 129.0	
20 Skött		16: 8.1 ← 17: 9.7 ↙ 18: 8.5 ➤ 19: 9.9 ↓ 20: 9.4 ↗			
		Serie 43.0			
		Total 172.0			

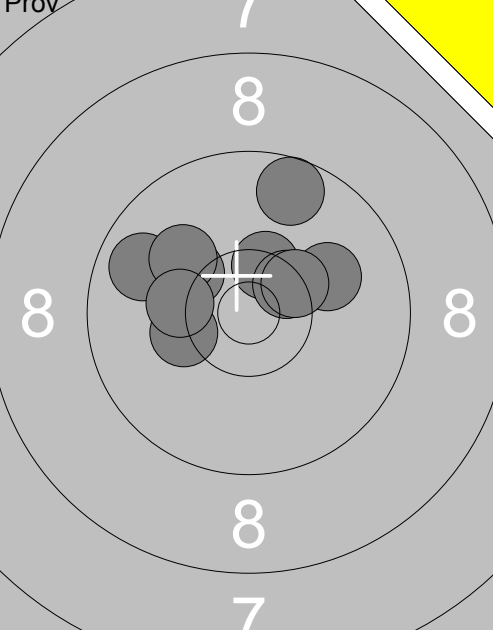
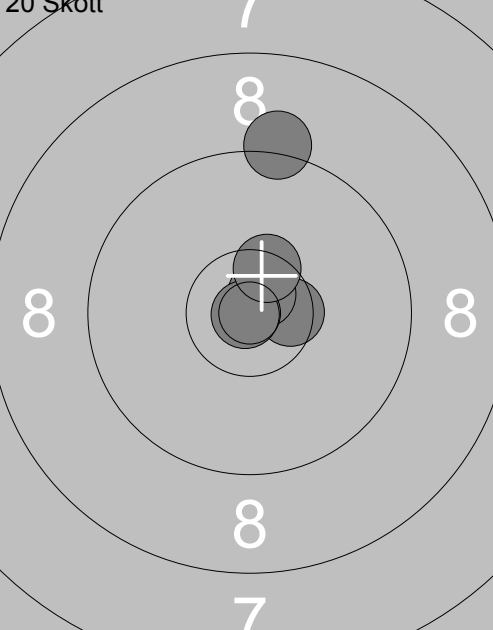
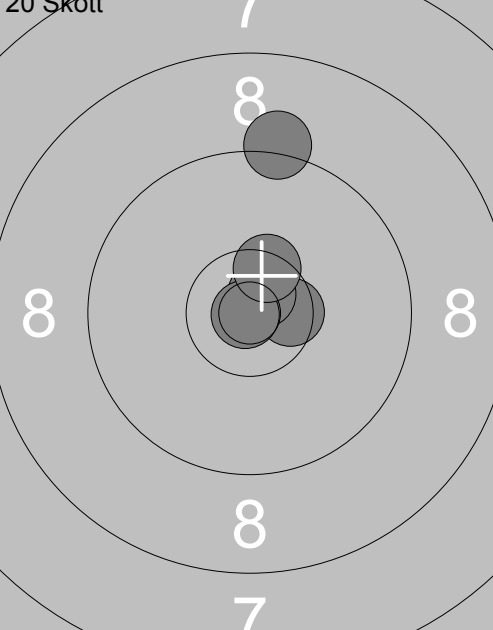
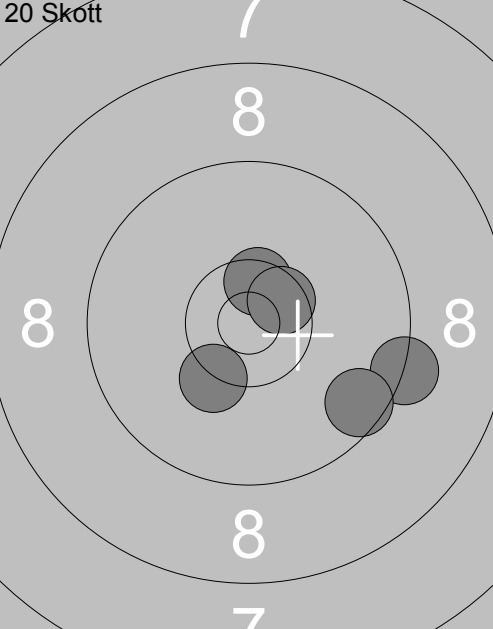
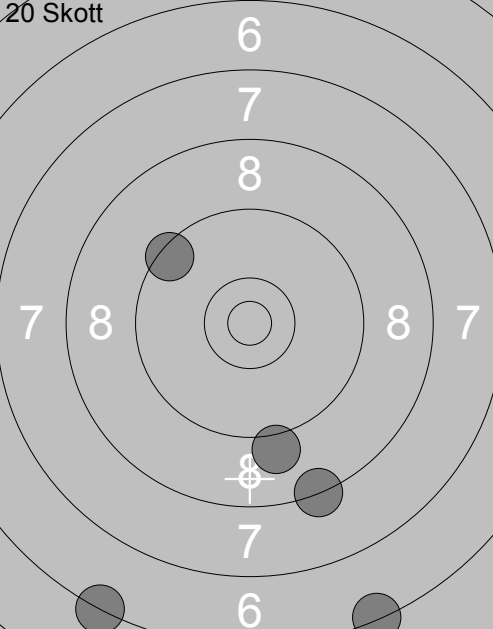
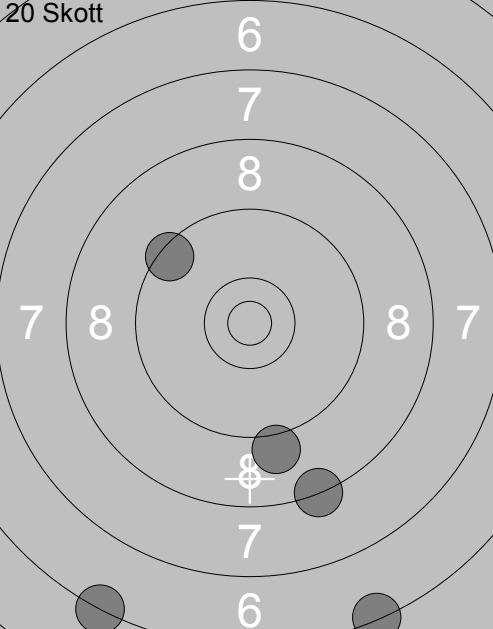
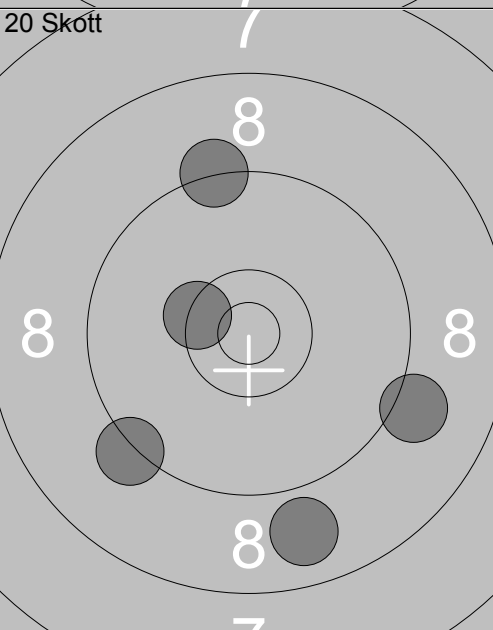
Skjutlag	Tavla	Lars Möllsten			
3	16	Vindeln	Umeå	Sen-S	Vb
11.07.2017	Tavelträffen Korthåll 2017	Ramselefors SKF			
Prov		1: 8.8 ↗ 2: 9.6 ↓ 3: 10.8↗ 4: 9.7 ↓ 5: 10.5↘ 6: 10.6↘ 7: 10.2← 8: 10.0→ 9: 10.5↗	20 Skott		1: 10.5↖ 2: 9.1 ↑ 3: 9.6 ↑ 4: 9.2 ↖ 5: 9.4 ↓
		Serie 86.0		Serie 46.0	
		Total 0.0		Total 46.0	
20 Skott		6: 10.4x↗ 7: 9.7 ↓ 8: 10.3x↓ 9: 9.9 ↘ 10: 10.7x↓	20 Skott		11: 10.6↘ 12: 9.0 ↑ 13: 9.8 → 14: 8.0 ↑ 15: 7.5 ↖
		Serie 48.0		Serie 43.0	
		Total 94.0		Total 137.0	
20 Skott		16: 9.7 ↗ 17: 8.5 ↗ 18: 8.6 → 19: 10.4x↗ 20: 10.3 ↗			
		Serie 45.0			
		Total 182.0			

<div style="text-align: center;">Prov</div> 	<div style="text-align: center;">20 Skott</div> 	<div style="text-align: center;">20 Skott</div> 
<p>1: 10.3 ←</p> <p>2: 10.1 →</p> <p>3: 9.6 ↑</p> <p>4: 10.4x ↗</p> <p>5: 10.5x ↗</p> <p>6: 10.2 ↖</p> <p>7: 9.8 ←</p> <p>8: 10.1 ↖</p> <p>9: 10.4x ↗</p> <p>10: 10.2 ←</p>	<p>1: 10.5x →</p> <p>2: 10.7x ↗</p> <p>3: 10.9x ↖</p> <p>4: 10.5x ↗</p> <p>5: 9.2 ↑</p>	<p>Serie 98.0</p> <p>Total 0.0</p>
<div style="text-align: center;">20 Skott</div> 	<div style="text-align: center;">20 Skott</div> 	<div style="text-align: center;">20 Skott</div> 
<p>6: 9.3 →</p> <p>7: 10.5x ↗</p> <p>8: 10.5x ↗</p> <p>9: 9.6 →</p> <p>10: 10.3 ↓</p>	<p>11: 6.3 ↓</p> <p>12: 8.3 ↓</p> <p>13: 9.1 ↓</p> <p>14: 6.3 ↓</p> <p>15: 9.4 ↖</p>	<p>Serie 48.0</p> <p>Total 97.0</p>
<div style="text-align: center;">20 Skott</div> 	<div style="text-align: center;">20 Skott</div> 	<div style="text-align: center;">20 Skott</div> 
<p>16: 9.2 ↓</p> <p>17: 10.4x ↖</p> <p>18: 8.9 ↓</p> <p>19: 9.3 ↑</p> <p>20: 9.1 →</p>	<p>Serie 45.0</p> <p>Total 180.0</p>	<p>Serie 38.0</p> <p>Total 135.0</p>

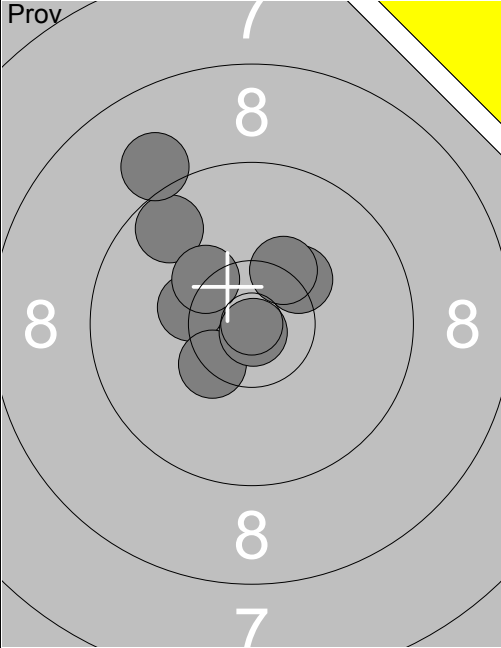
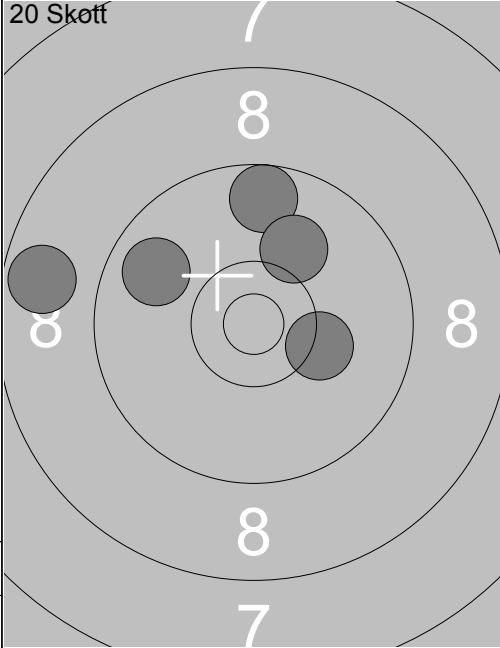
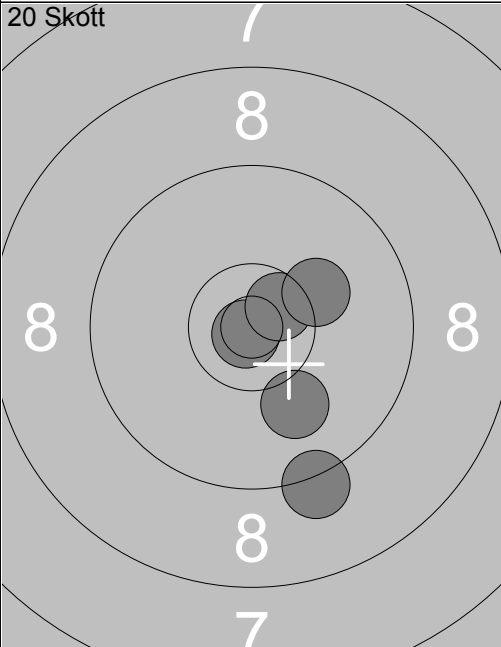
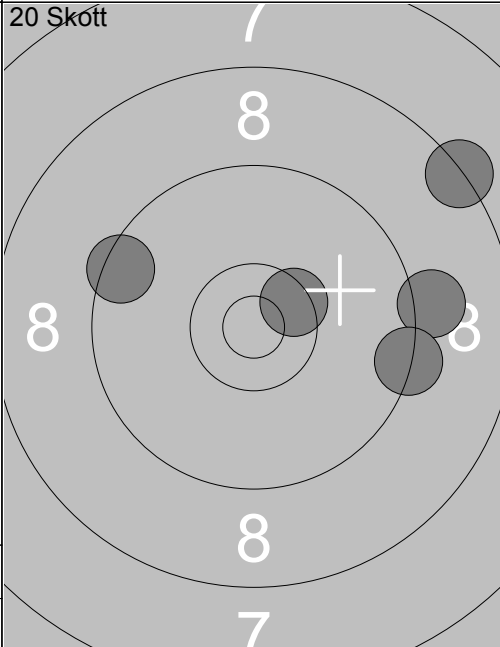
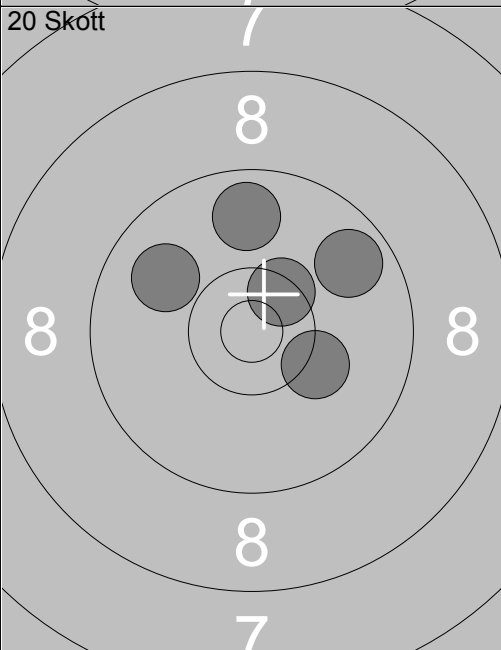
	<p>20 Skott</p> <p>1: 10.3 ↗ 2: 10.3 ↗ 3: 10.3 ↗ 4: 9.7 ↖ 5: 9.1 ↖ 6: 10.4 ↘ 7: 10.3 ↘ 8: 10.9 ↘</p> <p>Serie 78.0 Total 0.0</p>		<p>20 Skott</p> <p>1: 9.7 ↑ 2: 10.1 ↗ 3: 8.7 ← 4: 9.8 ↖ 5: 10.2 ⇒</p> <p>Serie 46.0 Total 46.0</p>
	<p>20 Skott</p> <p>6: 10.9 ↘ 7: 10.1 ↓ 8: 10.6 ↗ 9: 10.2 ↗ 10: 9.2 ↓</p> <p>Serie 49.0 Total 95.0</p>		<p>20 Skott</p> <p>11: 10.5 ↗ 12: 9.1 → 13: 9.5 ← 14: 9.3 ⇒ 15: 8.3 ↗</p> <p>Serie 45.0 Total 140.0</p>
	<p>20 Skott</p> <p>16: 10.2 ⇒ 17: 9.7 ↗ 18: 10.4 ↗ 19: 9.8 ↑ 20: 9.9 ↖</p> <p>Serie 47.0 Total 187.0</p>		

	<p>1: 10.2 ↘ 2: 9.9 ↘ 3: 9.1 ↓ 4: 9.5 ↘ 5: 9.5 ↑ 6: 10.3 → 7: 9.9 ↙ 8: 9.6 ↗ 9: 10.6x↑ 10: 9.1 ↑</p> <p>Serie 93.0 Total 0.0</p>		<p>11: 9.4 ← 12: 9.7 → 13: 10.6x↑</p> <p>Serie 28.0 Total 0.0</p>
<p>20 Skott</p>	<p>1: 10.4x↘ 2: 9.8 → 3: 10.1 ↓ 4: 9.7 ← 5: 10.6x↘</p> <p>Serie 48.0 Total 48.0</p>	<p>20 Skott</p>	<p>6: 10.6x↑ 7: 10.1 ↘ 8: 9.2 → 9: 10.7x↓ 10: 10.6x↘</p> <p>Serie 49.0 Total 97.0</p>
<p>20 Skott</p>	<p>11: 9.2 → 12: 7.9 ↘ 13: 9.4 ↓ 14: 7.9 → 15: 4.4 ↓</p> <p>Serie 36.0 Total 133.0</p>	<p>20 Skott</p>	<p>16: 8.9 → 17: 9.5 ↘ 18: 10.1 ↗ 19: 9.0 → 20: 10.3↙</p> <p>Serie 46.0 Total 179.0</p>

<p>Prov</p> <p style="text-align: center;">7 8 8 8 7</p>	<p>1: 8.9 ↗ 2: 9.3 ↗ 3: 10.5x↘ 4: 10.4x↗ 5: 9.9 ↖ 6: 8.6 ← 7: 9.8 ↗ 8: 10.5x↘ 9: 10.1 ↘ 10: 9.8 ↗</p> <p>Serie 92.0 Total 0.0</p>	<p>Prov</p> <p style="text-align: center;">7 8 8 8 7</p>	<p>11: 10.3x↘ 12: 10.1↖ 13: 10.8x↗</p> <p>Serie 30.0 Total 0.0</p>
<p>20 Skott</p> <p style="text-align: center;">7 8 8 8 7</p>	<p>1: 9.9 ← 2: 10.0 ↗ 3: 10.2 ↘ 4: 9.7 ↖ 5: 10.2 →</p> <p>Serie 48.0 Total 48.0</p>	<p>20 Skott</p> <p style="text-align: center;">7 8 8 8 7</p>	<p>6: 10.3 ↘ 7: 10.0 ↘ 8: 10.1 ↘ 9: 9.5 → 10: 10.5x↗</p> <p>Serie 49.0 Total 97.0</p>
<p>20 Skott</p> <p style="text-align: center;">4 5 6 7 8 8 7 6 5 5 6 7 8 8 7 6 5</p>	<p>11: 9.7 → 12: 9.6 ↘ 13: 5.8 ← 14: 9.4 ↘ 15: 9.0 ↘</p> <p>Serie 41.0 Total 138.0</p>	<p>20 Skott</p> <p style="text-align: center;">7 8 8 8 7</p>	<p>16: 9.4 ↖ 17: 10.0↖ 18: 8.6 ↗ 19: 8.0 ↘ 20: 10.0↖</p> <p>Serie 45.0 Total 183.0</p>

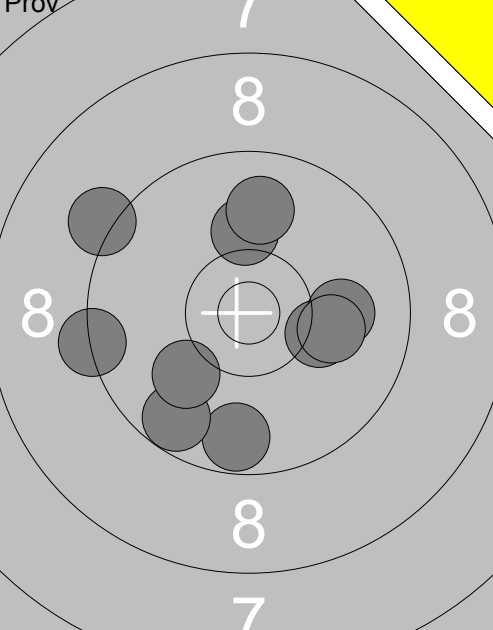
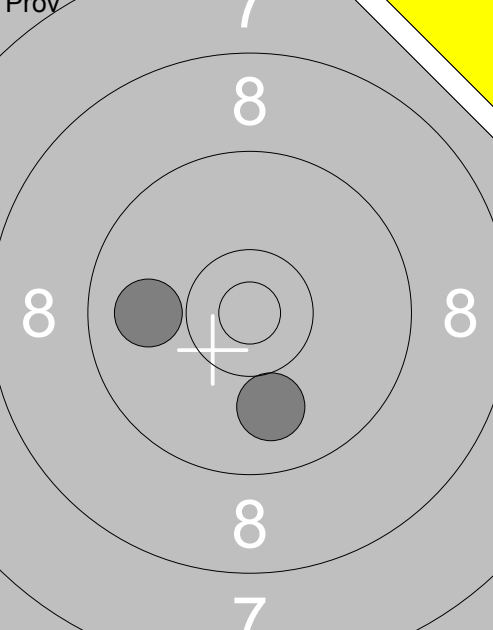
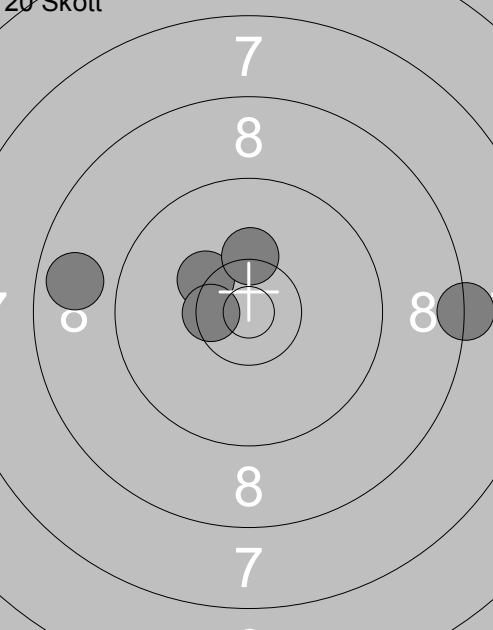
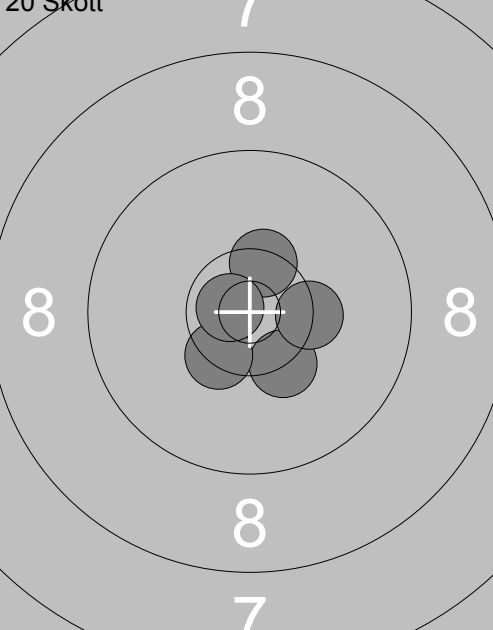
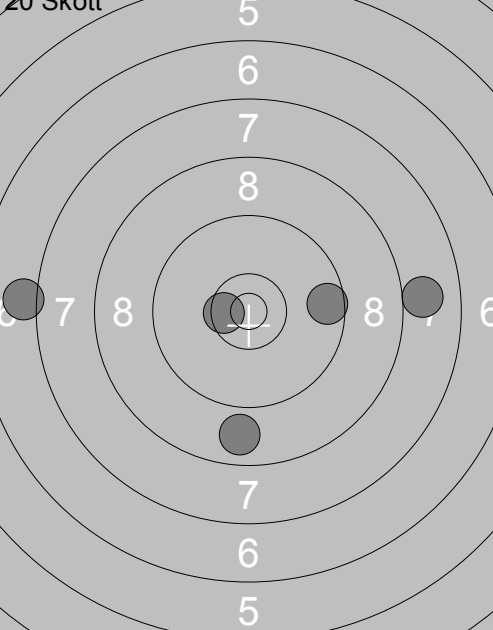
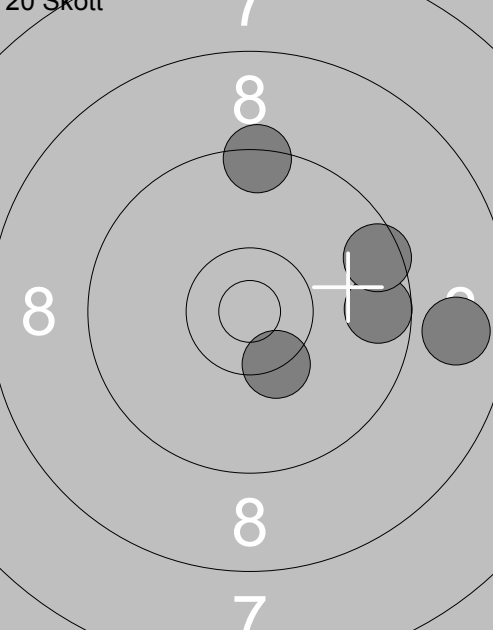
 <p>Prov</p>	<p>1: 9.2 ↖ 2: 10.2 → 3: 9.7 ↓ 4: 9.3 ← 5: 10.0 → 6: 9.7 ↙ 7: 10.1 ↑ 8: 9.9 ↑ 9: 10.1 → 10: 10.1 ↙</p>	 <p>Prov</p>	<p>11: 10.0 ↓ 12: 9.9 ←</p>
	Serie 95.0		Serie 19.0
	Total 0.0		Total 0.0
 <p>20 Skott</p>	<p>1: 10.3 ↖ 2: 10.3 ↑ 3: 8.8 ← 4: 10.5 ✕ 5: 8.3 →</p>	 <p>20 Skott</p>	<p>6: 10.3 ✕ 7: 10.3 ✕ 8: 10.4 ✕ 9: 10.4 ✕ 10: 10.7 ✕</p>
	Serie 46.0		Serie 50.0
	Total 46.0		Total 96.0
 <p>20 Skott</p>	<p>11: 9.6 → 12: 8.0 → 13: 7.1 ← 14: 10.5 ✕ 15: 8.8 ↓</p>	 <p>20 Skott</p>	<p>16: 9.6 → 17: 10.3 ✕ 18: 9.4 ↑ 19: 8.8 → 20: 9.5 →</p>
	Serie 42.0		Serie 45.0
	Total 138.0		Total 183.0

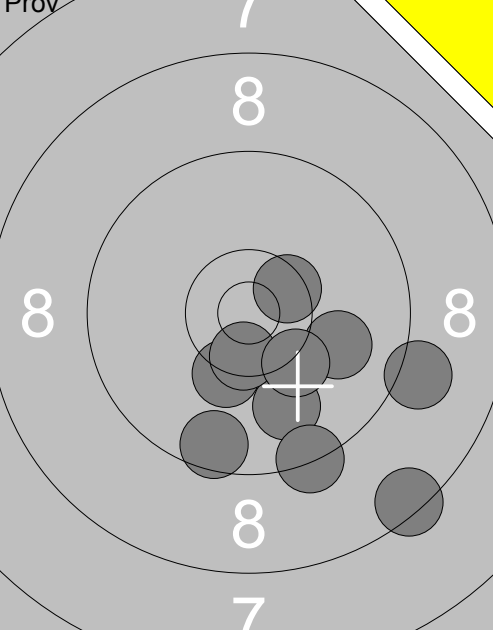
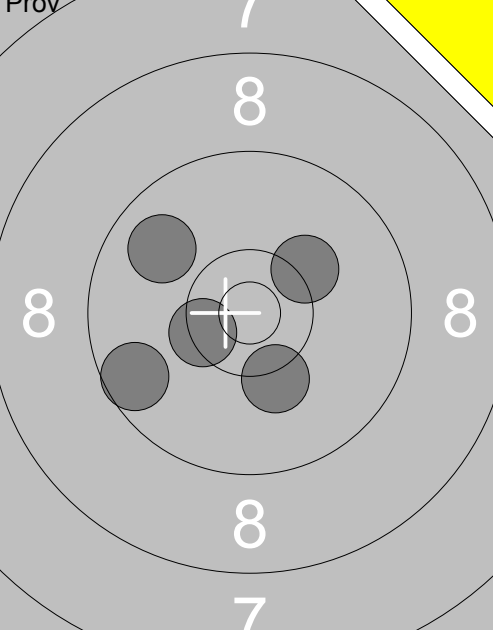
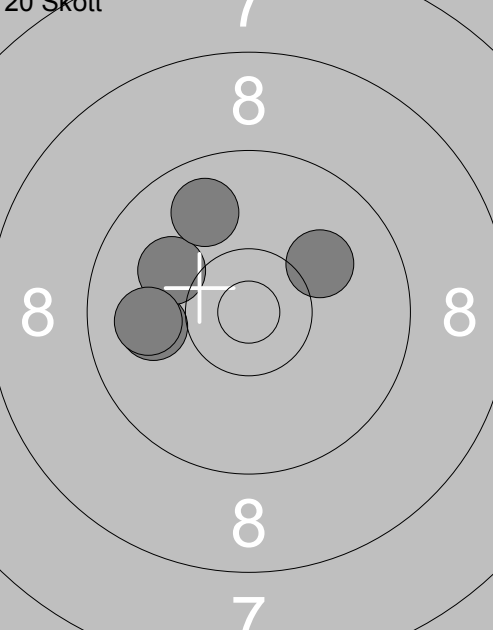
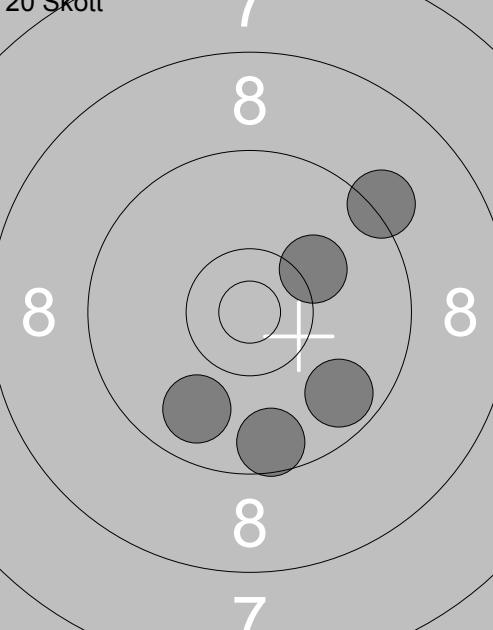
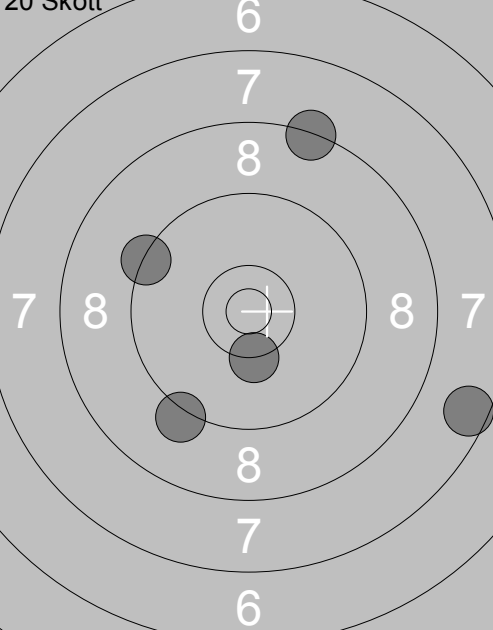
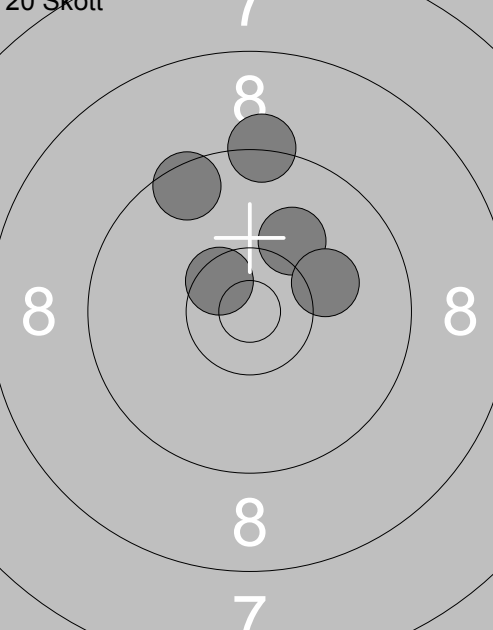
	<p>1: 8.4 ↘ 2: 9.6 ↓ 3: 10.3 ↓ 4: 9.1 → 5: 9.9 ↓ 6: 9.3 ↓ 7: 10.5x↗ 8: 10.5x↓ 9: 10.0 → 10: 10.3 ↘</p> <p>Serie 94.0 Total 0.0</p>		<p>11: 9.8 ↖ 12: 10.2 ↗ 13: 10.4x↖ 14: 10.2 ↓ 15: 9.6 ↙</p> <p>Serie 48.0 Total 0.0</p>
<p>20 Skott</p> 	<p>1: 10.0 ← 2: 10.1 ↖ 3: 9.8 ↗ 4: 10.1 ↗ 5: 9.9 ←</p> <p>Serie 48.0 Total 48.0</p>	<p>20 Skott</p> 	<p>6: 9.2 ↗ 7: 9.7 ↘ 8: 9.8 ↓ 9: 9.6 ↓ 10: 10.2 ↗</p> <p>Serie 46.0 Total 94.0</p>
<p>20 Skott</p> 	<p>11: 9.2 ↓ 12: 7.6 → 13: 8.3 ↗ 14: 10.3x↓ 15: 9.3 ↖</p> <p>Serie 43.0 Total 137.0</p>	<p>20 Skott</p> 	<p>16: 10.5x↖ 17: 9.5 ↖ 18: 10.1 ↗ 19: 10.1 → 20: 9.3 ↑</p> <p>Serie 48.0 Total 185.0</p>

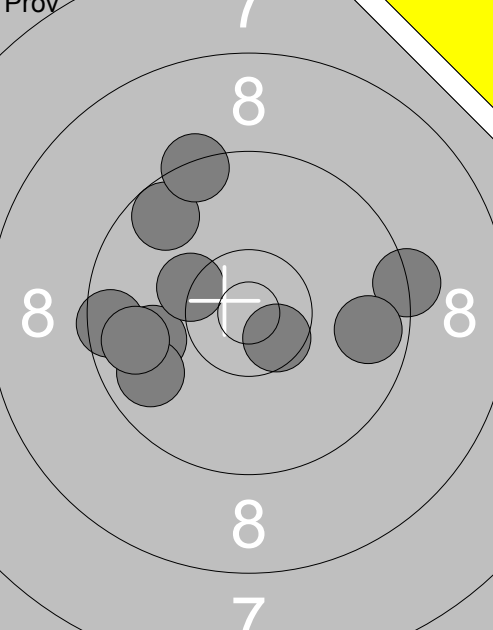
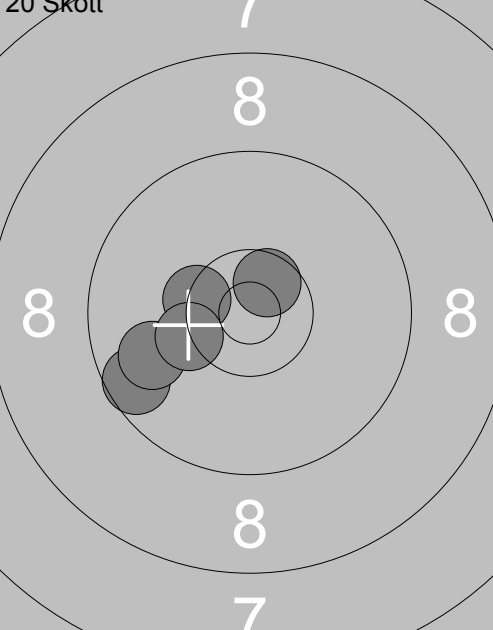
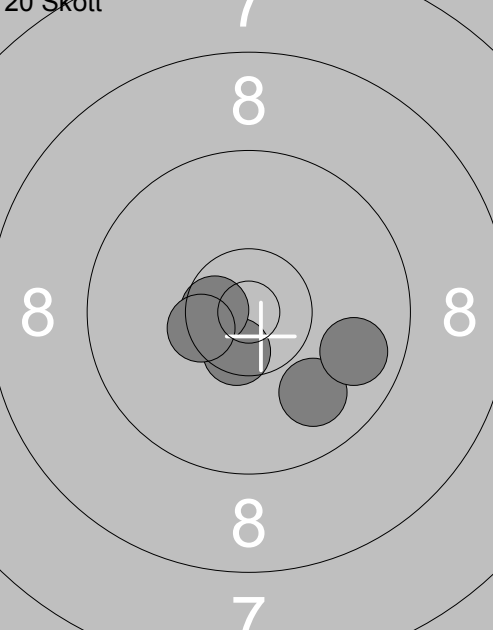
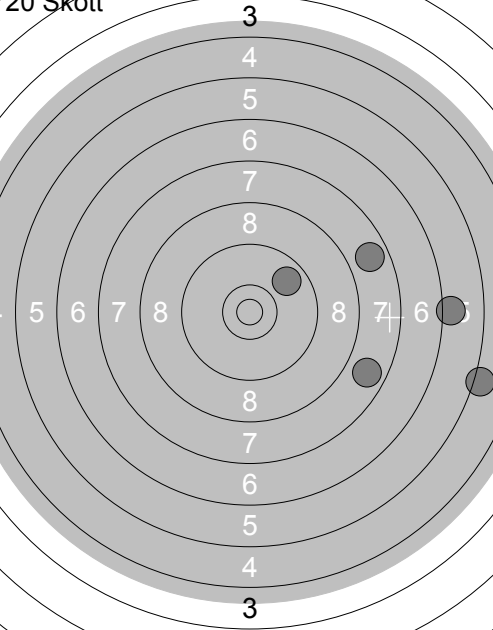
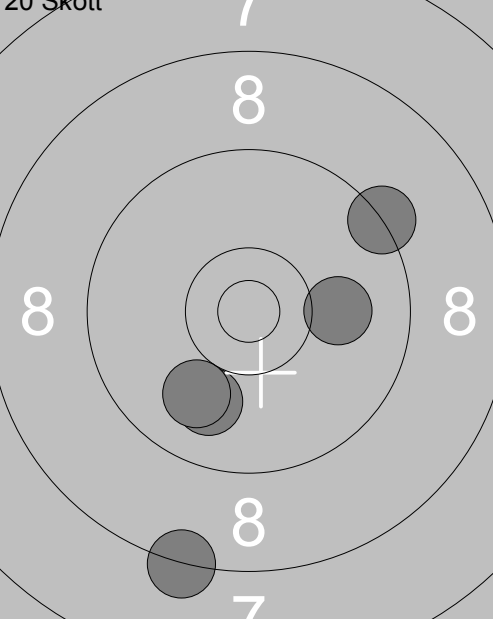
<div style="text-align: right; font-size: 0.8em;">Prov</div> 	<div style="text-align: right; font-size: 0.8em;">20 Skott</div> <ol style="list-style-type: none"> 1: 9.5 ← 2: 9.6 ↖ 3: 9.3 → 4: 9.4 ↗ 5: 9.9 ← 6: 9.7 → 7: 9.8 ↙ 8: 10.3 ✕ 9: 10.6 ✕ 10: 9.8 ← <table border="1" style="width:100%; border-collapse: collapse; margin-top: 5px;"> <tr><td style="text-align: right;">Serie</td><td style="text-align: left;">92.0</td></tr> <tr><td style="text-align: right;">Total</td><td style="text-align: left;">0.0</td></tr> </table>	Serie	92.0	Total	0.0	<div style="text-align: right; font-size: 0.8em;">20 Skott</div>  <ol style="list-style-type: none"> 1: 10.6 ✕ 2: 9.6 ↙ 3: 10.4 ✕ 4: 9.9 ← 5: 10.3 ✕ <table border="1" style="width:100%; border-collapse: collapse; margin-top: 5px;"> <tr><td style="text-align: right;">Serie</td><td style="text-align: left;">48.0</td></tr> <tr><td style="text-align: right;">Total</td><td style="text-align: left;">48.0</td></tr> </table>	Serie	48.0	Total	48.0
Serie	92.0									
Total	0.0									
Serie	48.0									
Total	48.0									
<div style="text-align: right; font-size: 0.8em;">20 Skott</div> 	<ol style="list-style-type: none"> 6: 9.9 ↘ 7: 10.5 ✕ 8: 9.8 → 9: 10.6 ✕ 10: 10.4 ✕ <table border="1" style="width:100%; border-collapse: collapse; margin-top: 5px;"> <tr><td style="text-align: right;">Serie</td><td style="text-align: left;">48.0</td></tr> <tr><td style="text-align: right;">Total</td><td style="text-align: left;">96.0</td></tr> </table>	Serie	48.0	Total	96.0	<div style="text-align: right; font-size: 0.8em;">20 Skott</div>  <ol style="list-style-type: none"> 11: 7.8 ⇒ 12: 7.7 ↗ 13: 5.1 ⇒ 14: 6.1 → 15: 9.8 ↗ <table border="1" style="width:100%; border-collapse: collapse; margin-top: 5px;"> <tr><td style="text-align: right;">Serie</td><td style="text-align: left;">34.0</td></tr> <tr><td style="text-align: right;">Total</td><td style="text-align: left;">130.0</td></tr> </table>	Serie	34.0	Total	130.0
Serie	48.0									
Total	96.0									
Serie	34.0									
Total	130.0									
<div style="text-align: right; font-size: 0.8em;">20 Skott</div> 	<ol style="list-style-type: none"> 16: 9.9 ↘ 17: 9.3 ↗ 18: 10.0 ↘ 19: 10.0 → 20: 8.3 ↘ <table border="1" style="width:100%; border-collapse: collapse; margin-top: 5px;"> <tr><td style="text-align: right;">Serie</td><td style="text-align: left;">46.0</td></tr> <tr><td style="text-align: right;">Total</td><td style="text-align: left;">176.0</td></tr> </table>	Serie	46.0	Total	176.0					
Serie	46.0									
Total	176.0									

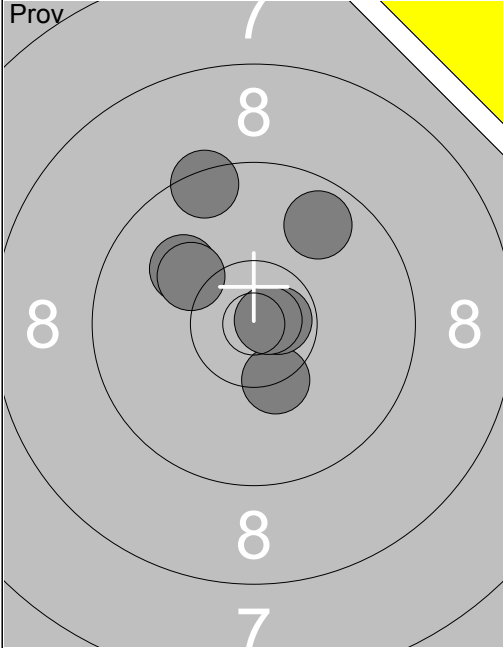
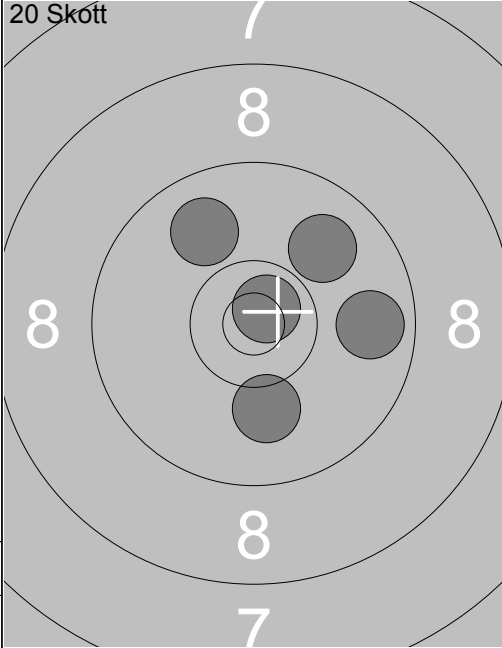
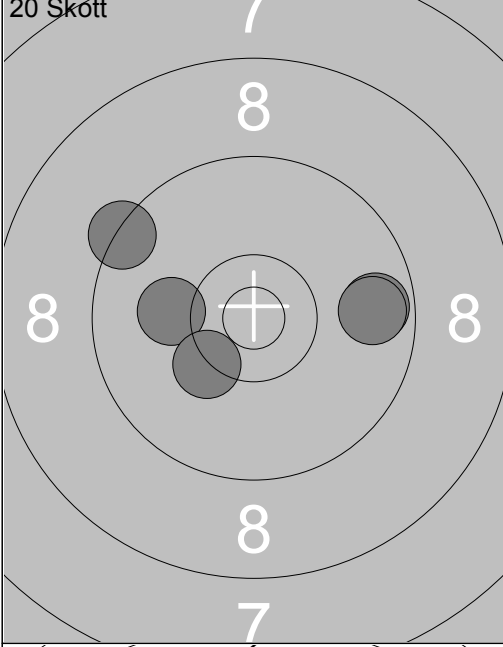
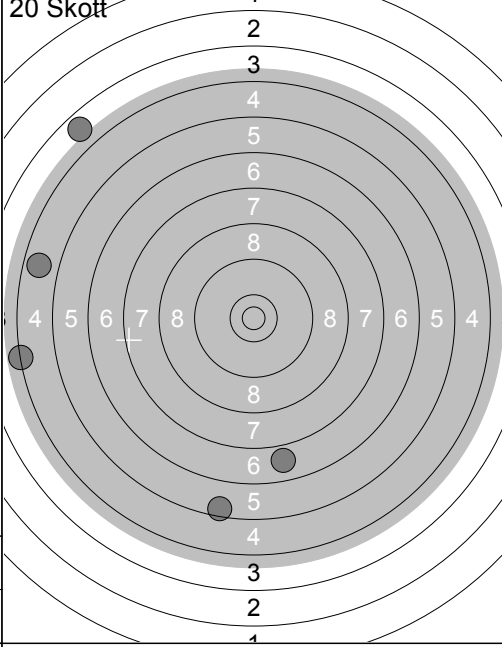
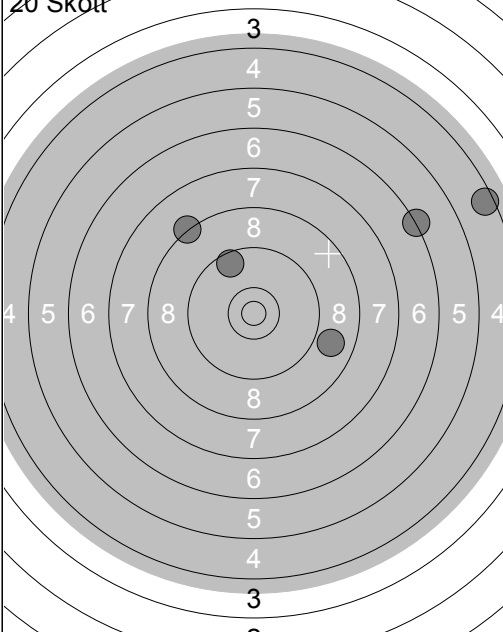
Skjutlag 4	Tavla 1	Stefan Thorin		
Vindeln	Umeå	Sen-S	Vb	
11.07.2017	Tavelträffen Korthåll 2017	Ramselefors SKF		
Prov		1: 9.7 ↗ 2: 10.3x↘ 3: 10.0 ↖ 4: 10.7x➔ 5: 10.1 ↖ 6: 9.4 ↗ 7: 10.8x➔	20 Skott	 1: 10.1 ↓ 2: 9.9 ↗ 3: 9.8 ➔ 4: 10.7x↗ 5: 9.9 ↖
	Serie 68.0		Serie 47.0	
	Total 0.0		Total 47.0	
20 Skott		6: 9.4 ↖ 7: 10.1↖ 8: 9.7 ➔ 9: 9.7 ➔ 10: 10.3↘	20 Skott	 11: 4.3 ← 12: 3.7 ↖ 13: 6.9 ↓ 14: 4.7 ← 15: 5.5 ↓
	Serie 47.0		Serie 22.0	
	Total 94.0		Total 116.0	
20 Skott		16: 8.3 ↗ 17: 8.9 ➔ 18: 4.5 ➔ 19: 6.3 ↗ 20: 9.6 ↖		
	Serie 35.0			
	Total 151.0			

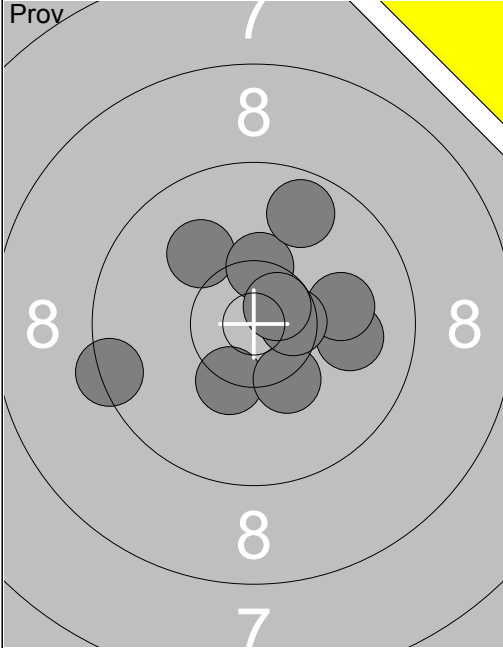
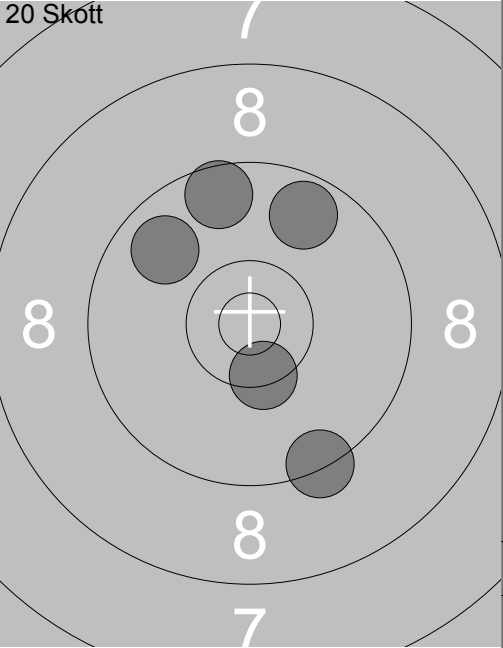
	<p>20 Skott</p> <p>1: 10.3x ↘ 2: 9.4 ← 3: 10.1 ↖ 4: 10.3x ↘ 5: 10.0 → 6: 10.0 → 7: 10.6x → 8: 10.4x ↑ 9: 9.7 ↗ 10: 10.7x ↗</p> <p>Serie 98.0 Total 0.0</p>	 <p>20 Skott</p> <p>1: 9.4 ↘ 2: 9.6 ↑ 3: 10.4x ↘ 4: 9.8 ↖ 5: 9.7 ↗</p> <p>Serie 46.0 Total 46.0</p>
--	--	---

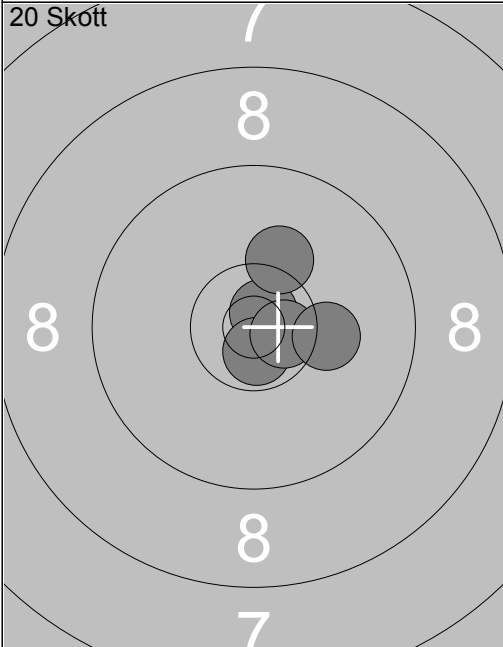
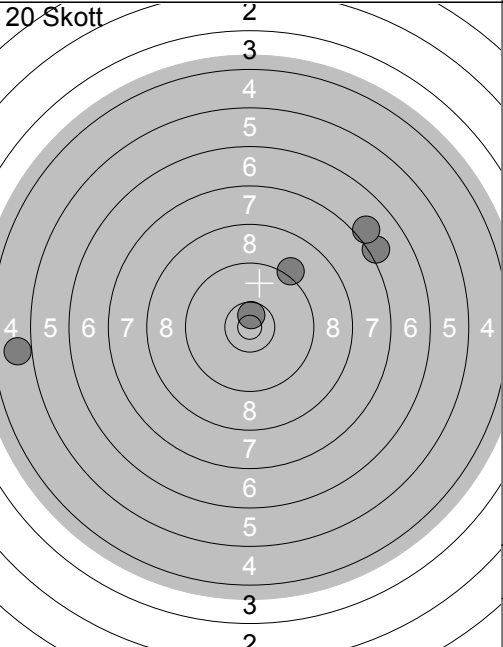
 <p>20 Skott</p> <p>6: 10.8x ↗ 7: 10.2 ↑ 8: 10.7x ↘ 9: 10.6x → 10: 10.2 →</p> <p>Serie 50.0 Total 96.0</p>	 <p>20 Skott</p> <p>11: 4.9 ← 12: 7.1 ↗ 13: 7.0 ↗ 14: 9.2 ↗ 15: 10.6x ↑</p> <p>Serie 37.0 Total 133.0</p>
---	--

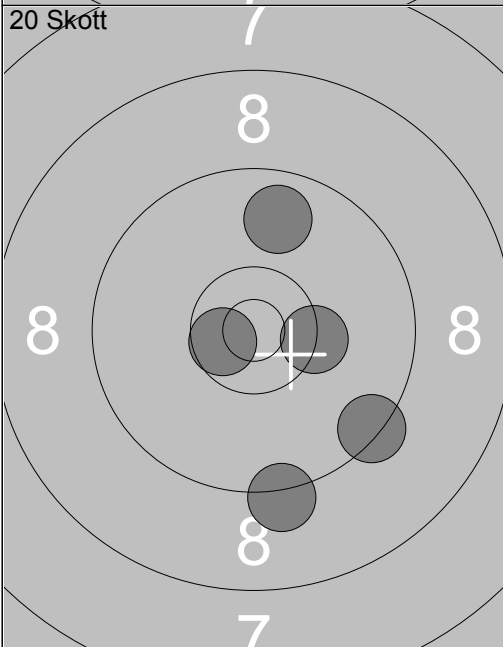
 <p>20 Skott</p> <p>16: 10.6x ↘ 17: 9.8 ↑ 18: 9.4 ↘ 19: 9.2 ↘ 20: 10.3x →</p> <p>Serie 47.0 Total 180.0</p>		
---	--	--

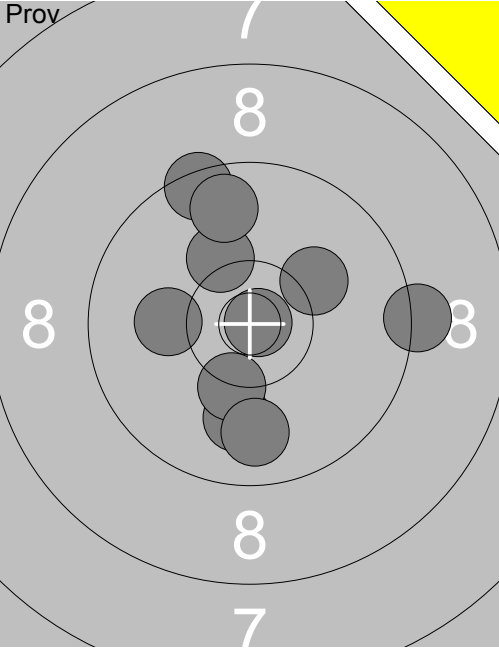
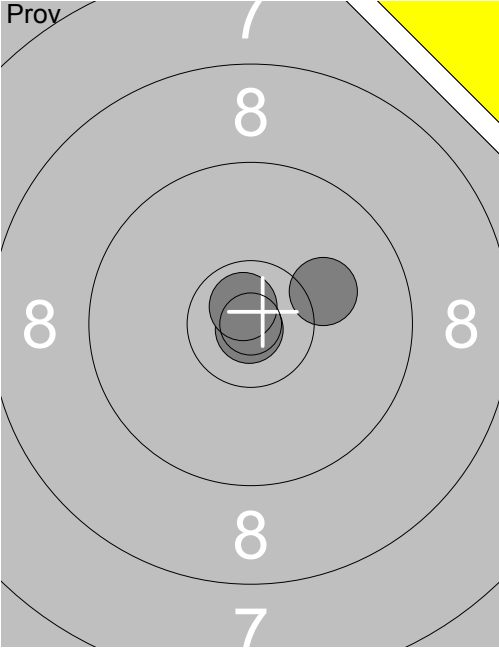
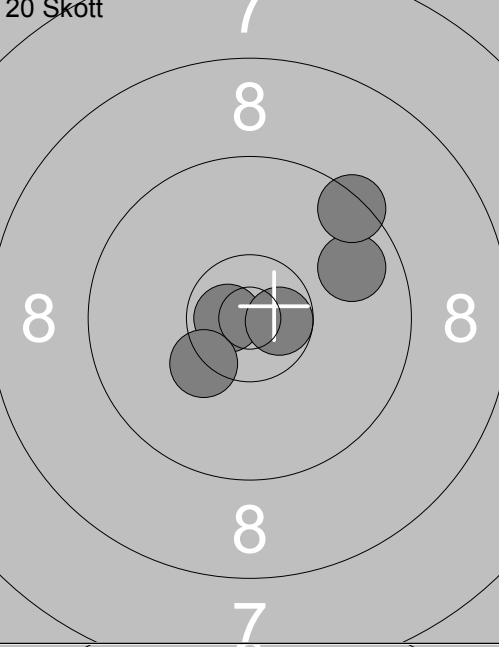
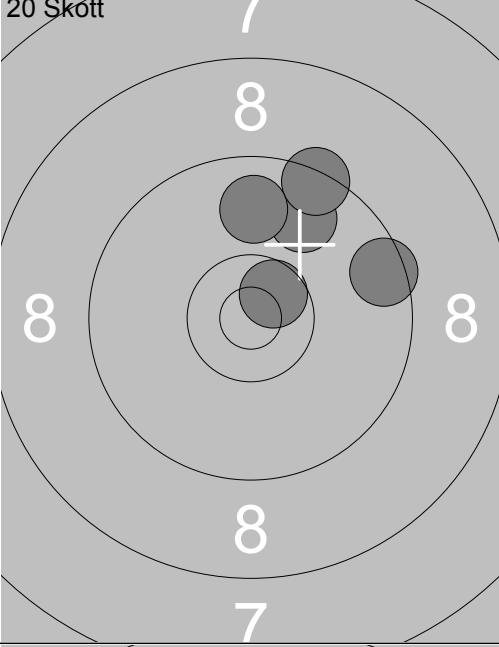
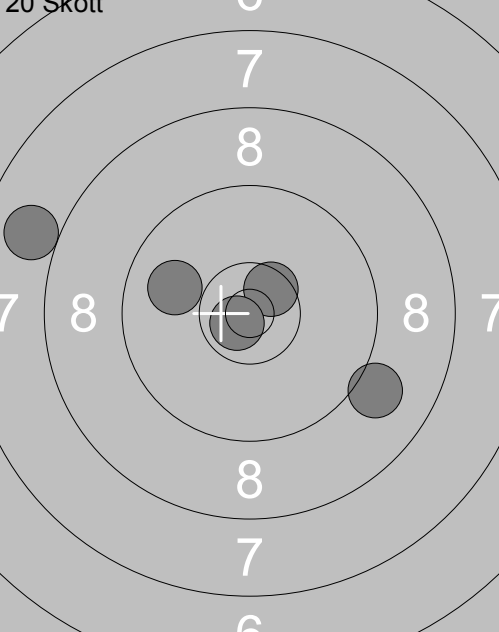
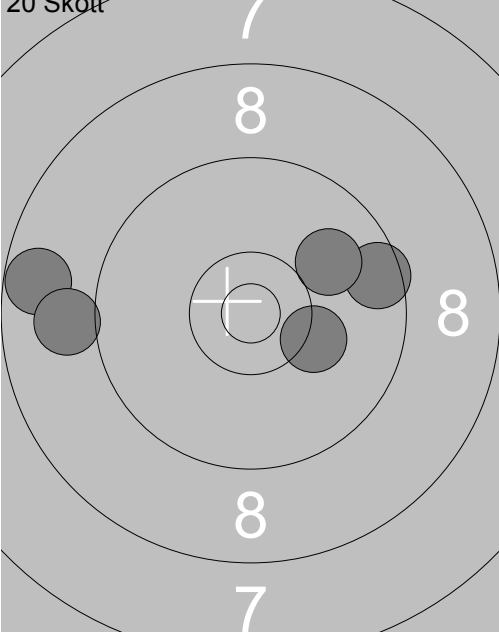
Skjutlag	Tavla	William Grydén			
4	3	Vaksala	Jun-S	Up	
11.07.2017	Tavelträffen Korthåll 2017	Ramselefors SKF			
Prov		1: 10.0 ↓ 2: 10.2 ↗ 3: 9.5 ↗ 4: 9.7 ↗ 5: 10.1 ← 6: 10.2 ↗ 7: 9.2 → 8: 10.9x → 9: 10.3x ↓ 10: 9.8 ↓	Prov		11: 10.9x ↓ 12: 10.8x ↘ 13: 10.1 →
		Serie 96.0			Serie 30.0
		Total 0.0			Total 0.0
20 Skott		1: 9.8 → 2: 10.7x ← 3: 10.3x ↓ 4: 10.6x → 5: 9.4 ↗	20 Skott		6: 9.8 ↗ 7: 9.5 → 8: 9.4 ↗ 9: 10.6x ↗ 10: 9.8 ↗
		Serie 48.0			Serie 46.0
		Total 48.0			Total 94.0
20 Skott		11: 9.0 ↘ 12: 7.9 ← 13: 9.9 ← 14: 10.5x ↗ 15: 10.7x ↓	20 Skott		16: 9.5 → 17: 10.0 ↗ 18: 8.7 ← 19: 10.2 → 20: 9.0 ←
		Serie 45.0			Serie 46.0
		Total 139.0			Total 185.0

	<p>20 Skott</p> <p>1: 8.7 ←</p> <p>2: 10.4x ↘</p> <p>3: 10.2 ↖</p> <p>4: 9.2 ←</p> <p>5: 9.5 ↓</p> <p>6: 9.6 ←</p> <p>7: 9.3 ←</p> <p>8: 10.3 ←</p> <p>9: 10.0 ↙</p> <p>10: 10.3x ↘</p>		<p>20 Skott</p> <p>1: 9.4 ↓</p> <p>2: 9.3 ↓</p> <p>3: 9.4 ↘</p> <p>4: 10.4x ↓</p> <p>5: 8.5 ←</p>
Serie 94.0	Serie 45.0	Serie 45.0	Serie 45.0
Total 0.0	Total 45.0	Total 45.0	Total 45.0

<p>20 Skott</p>	<p>20 Skott</p> <p>6: 10.4x ↑</p> <p>7: 9.5 ↗</p> <p>8: 10.0 ←</p> <p>9: 9.4 ←</p> <p>10: 9.6 →</p>		<p>11: 8.9 ↑</p> <p>12: 1.5 ↓</p> <p>13: 5.6 ↓</p> <p>14: 8.4 ↓</p> <p>15: 4.0 ↓</p>
Serie 47.0	Serie 26.0	Serie 26.0	Serie 26.0
Total 92.0	Total 118.0	Total 118.0	Total 118.0

<p>20 Skott</p>	<p>16: 7.0 ↗</p> <p>17: 8.4 →</p> <p>18: 9.5 ↓</p> <p>19: 9.9 →</p> <p>20: 8.7 →</p>		
Serie 41.0	Serie 41.0	Serie 41.0	Serie 41.0
Total 159.0	Total 159.0	Total 159.0	Total 159.0

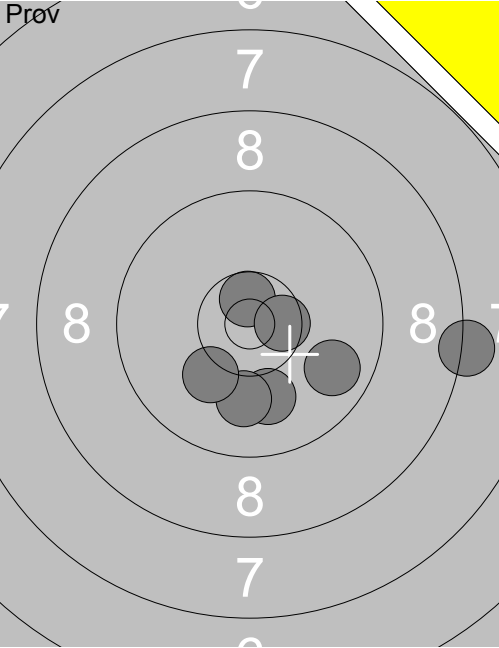
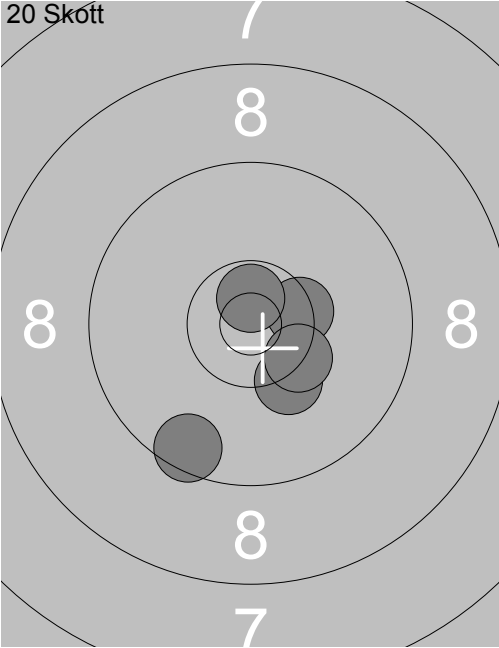
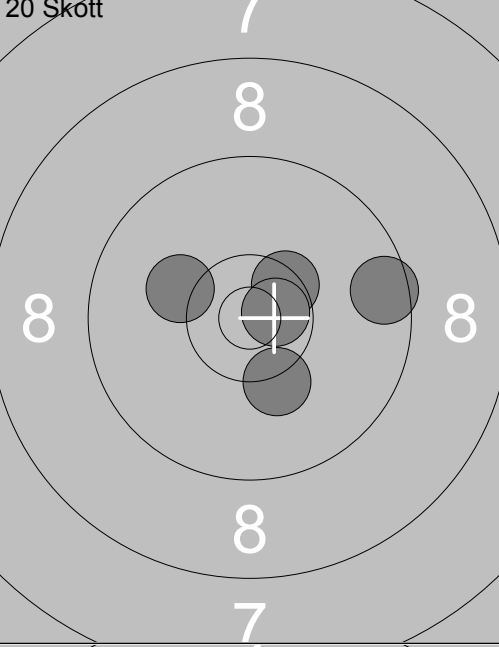
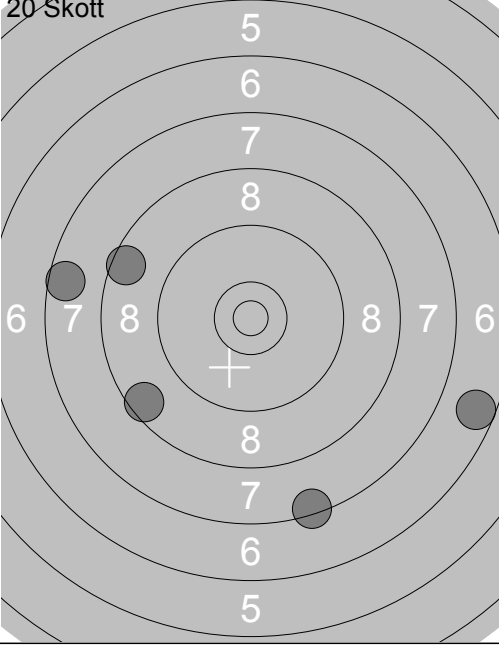
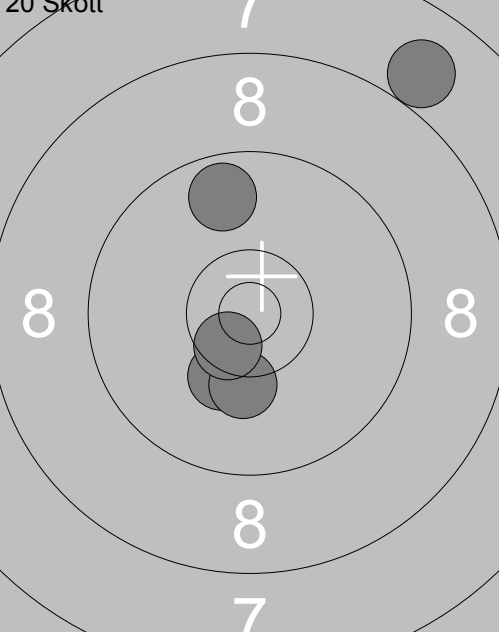
Skjuttag	Tavla	Jan-Ola Olsson			
4	5	Vindeln	Öved-Östraby	Sen-S	Sk
11.07.2017	Tavelträffen Korthåll 2017	Ramselefors SKF			
Pröv 	1: 10.0 ↓ 2: 10.6x ↑ 3: 10.5x → 4: 8.2 → 5: 9.8 → 6: 10.0 ↓ 7: 10.2 ↓	20 Skott 	1: 10.4x → 2: 10.3 ↓ 3: 10.4x → 4: 9.5 ↓ 5: 10.7x ↑		
	Serie 67.0		Serie 49.0		
	Total 0.0		Total 49.0		
20 Skott 	6: 10.5x ↗ 7: 10.2 ↓ 8: 10.7x → 9: 10.2 ↙ 10: 9.5 →	20 Skott 	11: 8.5 ↙ 12: 6.6 → 13: 7.4 ↓ 14: 7.6 ↙ 15: 8.5 ↙		
	Serie 49.0		Serie 36.0		
	Total 98.0		Total 134.0		
20 Skott 	16: 9.7 ↑ 17: 7.9 ↗ 18: 10.2 ↓ 19: 10.2 ↓ 20: 10.5x ↘				
	Serie 46.0				
	Total 180.0				

Skjutlag	Tavla	Henrik Olsson			
4	6	Vindeln	Öved-Östraby	Jun-S	Sk
11.07.2017	Tavelträffen Korthåll 2017	Ramselefors SKF			
Prov		1: 9.6 ↓ 2: 10.1 ↙ 3: 9.9 → 4: 7.6 ↓ 5: 9.4 ↓ 6: 8.2 ↙ 7: 10.1 ↗ 8: 9.7 ↓ 9: 9.2 ↙ 10: 10.1 ↓	Prov		11: 8.9 ↙
	Serie 90.0		Serie 8.0		
	Total 0.0		Total 0.0		
20 Skott		1: 9.3 ↓ 2: 9.4 ↓ 3: 9.8 ← 4: 9.6 ← 5: 9.2 ←	20 Skott		6: 10.1 ↓ 7: 10.3 ↙ 8: 10.4x ↑ 9: 10.7x ↓ 10: 9.4 ↗
	Serie 45.0		Serie 49.0		
	Total 45.0		Total 94.0		
20 Skott		11: 6.5 ↖ 12: 8.7 → 13: 6.4 ↗ 14: 9.6 ↗ 15: 8.5 →	20 Skott		16: 10.3 ↙ 17: 9.0 ↑ 18: 8.9 → 19: 9.1 ↗ 20: 10.4x ↙
	Serie 37.0		Serie 46.0		
	Total 131.0		Total 177.0		

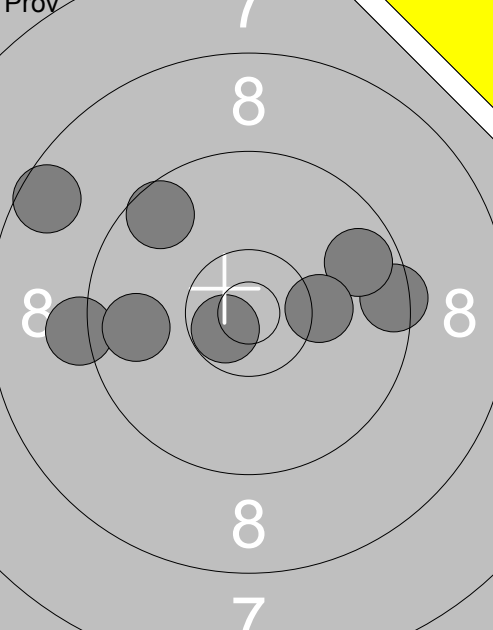
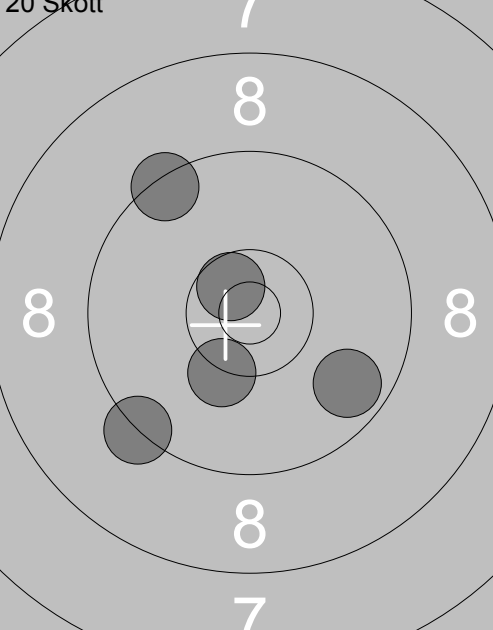
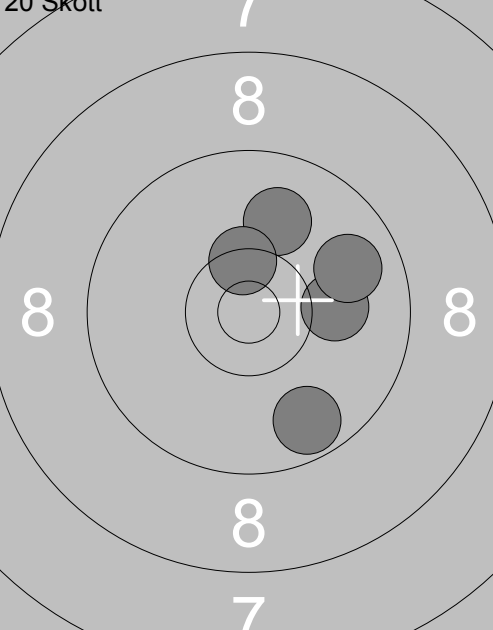
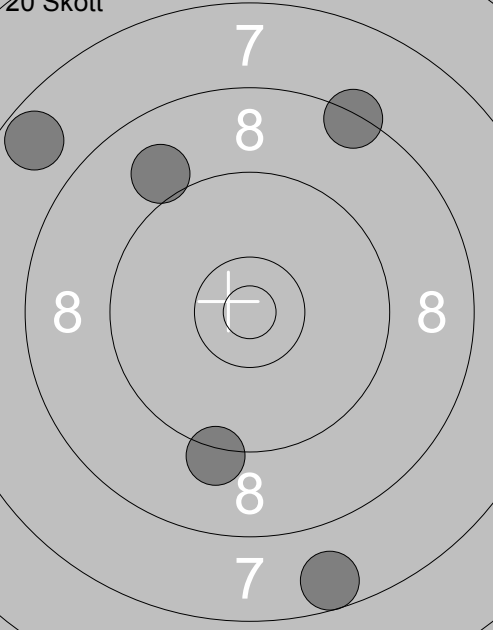
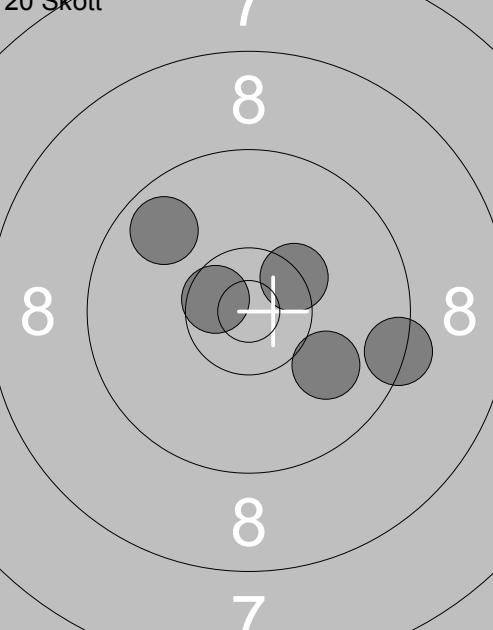
 <p style="text-align: center;">8 8 8 7</p>	<p>20 Skott</p> <p>1: 9.2 ← 2: 9.6 ↗ 3: 8.6 ↖ 4: 9.5 → 5: 9.7 ↗</p> <p>6: 10.2 → 7: 9.8 ← 8: 10.7 ✕</p> <p>Serie 73.0 Total 0.0</p>	 <p style="text-align: center;">8 8 8 7</p>	<p>1: 10.6 ✕ 2: 9.4 ↖ 3: 10.3 ↓ 4: 9.3 ↙ 5: 9.7 ↘</p> <p>Serie 47.0 Total 47.0</p>
 <p style="text-align: center;">8 8 8 7</p>	<p>20 Skott</p> <p>6: 9.7 ↓ 7: 10.1 → 8: 10.0 ↑ 9: 10.4 ✕ 10: 9.9 ↗</p> <p>Serie 48.0 Total 95.0</p>	 <p style="text-align: center;">7 8 8 7</p>	<p>11: 9.2 ↓ 12: 7.6 ↓ 13: 8.4 ↗ 14: 7.7 ↖ 15: 9.0 ↖</p> <p>Serie 40.0 Total 135.0</p>
 <p style="text-align: center;">8 8 8 7</p>	<p>20 Skott</p> <p>16: 10.0 ↘ 17: 10.4 ✕ 18: 9.4 → 19: 9.8 ↖ 20: 10.6 ✕</p> <p>Serie 48.0 Total 183.0</p>		

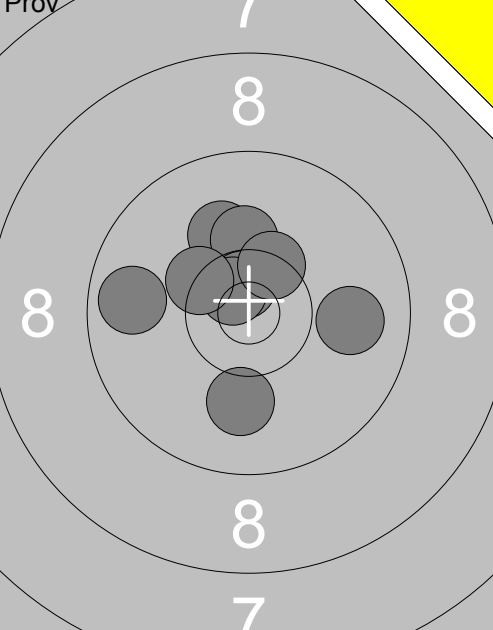
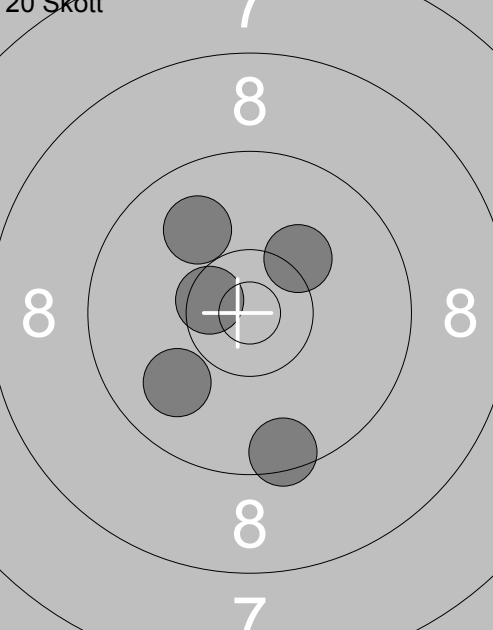
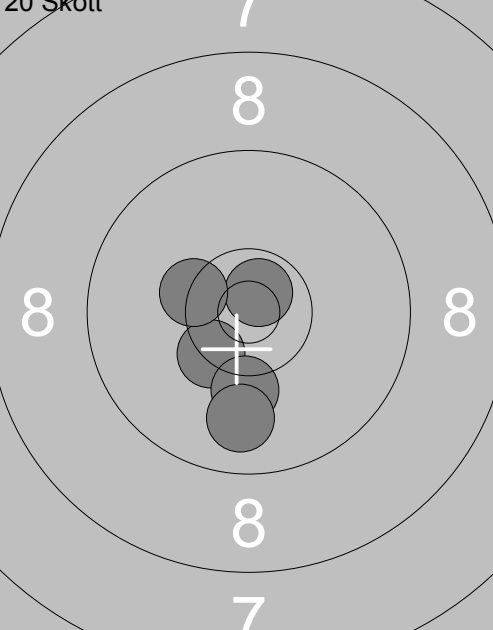
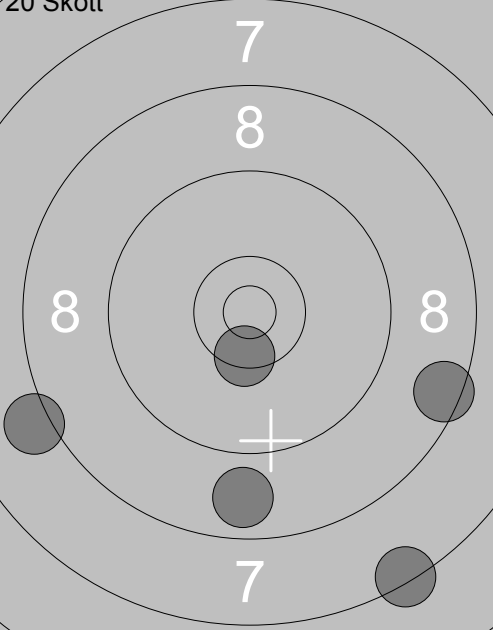
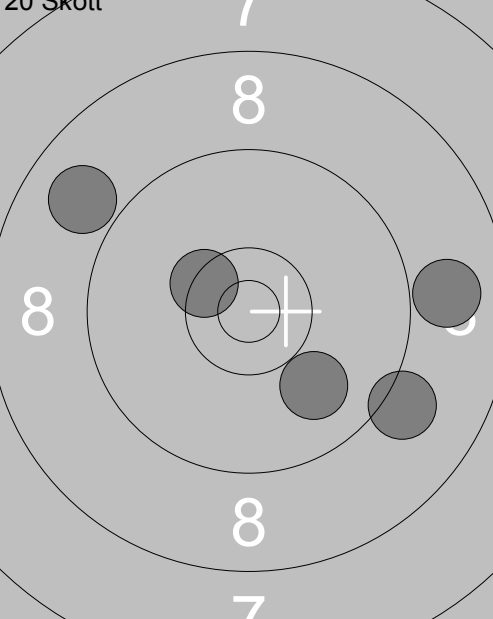
<div style="text-align: right; font-size: 0.8em; margin-bottom: 5px;">Prov</div> 	<div style="text-align: right; font-size: 0.8em; margin-bottom: 5px;">20 Skott</div> 	<div style="text-align: right; font-size: 0.8em; margin-bottom: 5px;">1: 10.2 ↗</div> <div style="text-align: right; font-size: 0.8em; margin-bottom: 5px;">2: 9.5 ↓</div> <div style="text-align: right; font-size: 0.8em; margin-bottom: 5px;">3: 9.9 ↙</div> <div style="text-align: right; font-size: 0.8em; margin-bottom: 5px;">4: 10.5 ✕</div> <div style="text-align: right; font-size: 0.8em; margin-bottom: 5px;">5: 9.9 ↖</div>
1: 9.9 → 2: 9.8 ← 3: 10.6 ✕ 4: 10.1 ↗ 5: 10.2 ↑ 6: 10.0 ↓ 7: 10.7 ✕ 8: 10.7 ✕ 9: 10.4 ✕ 10: 10.4 ✕	Serie 98.0 Total 0.0	Serie 47.0 Total 47.0
<div style="text-align: right; font-size: 0.8em; margin-bottom: 5px;">20 Skott</div> 	<div style="text-align: right; font-size: 0.8em; margin-bottom: 5px;">20 Skott</div> 	<div style="text-align: right; font-size: 0.8em; margin-bottom: 5px;">11: 7.4 ↓</div> <div style="text-align: right; font-size: 0.8em; margin-bottom: 5px;">12: 8.1 ↙</div> <div style="text-align: right; font-size: 0.8em; margin-bottom: 5px;">13: 8.8 ↓</div> <div style="text-align: right; font-size: 0.8em; margin-bottom: 5px;">14: 10.4 ✕</div> <div style="text-align: right; font-size: 0.8em; margin-bottom: 5px;">15: 8.5 →</div>
6: 10.4 ✕ 7: 10.2 ↓ 8: 10.7 ✕ 9: 9.9 ↓ 10: 10.4 ✕	Serie 49.0 Total 96.0	Serie 41.0 Total 137.0
<div style="text-align: right; font-size: 0.8em; margin-bottom: 5px;">20 Skott</div> 	<div style="text-align: right; font-size: 0.8em; margin-bottom: 5px;">16: 8.9 ↖</div> <div style="text-align: right; font-size: 0.8em; margin-bottom: 5px;">17: 9.9 ↓</div> <div style="text-align: right; font-size: 0.8em; margin-bottom: 5px;">18: 10.4 ✕</div> <div style="text-align: right; font-size: 0.8em; margin-bottom: 5px;">19: 8.9 →</div> <div style="text-align: right; font-size: 0.8em; margin-bottom: 5px;">20: 9.1 ↘</div>	
Serie 44.0 Total 181.0		

<p>Prov</p> <p>1: 9.0 ↘ 2: 9.7 ↓ 3: 9.8 ↗ 4: 10.2 ↘ 5: 9.8 ↙ 6: 9.4 ↗ 7: 9.4 ← 8: 9.9 ↗ 9: 10.6x ← 10: 9.2 ←</p> <p>Serie 92.0 Total 0.0</p>	<p>Prov</p> <p>11: 10.4x ↓ 12: 10.6x ↘ 13: 9.7 ↓ 14: 10.6x ↑ 15: 10.1 ↑</p> <p>Serie 49.0 Total 0.0</p>
<p>20 Skott</p> <p>1: 10.1 ↓ 2: 9.4 ↘ 3: 9.3 ↘ 4: 8.9 ↘ 5: 10.4x ↘</p> <p>Serie 46.0 Total 46.0</p>	<p>20 Skott</p> <p>6: 10.6x ↗ 7: 10.4x ↘ 8: 10.5x ← 9: 10.2 ↓ 10: 10.9x ↘</p> <p>Serie 50.0 Total 96.0</p>
<p>20 Skott</p> <p>11: 9.4 ↗ 12: 5.3 ↓ 13: 10.4x → 14: 9.1 ↙ 15: 9.6 ↙</p> <p>Serie 42.0 Total 138.0</p>	<p>20 Skott</p> <p>16: 8.9 ↙ 17: 7.5 ↗ 18: 8.1 ← 19: 8.7 ↓ 20: 7.5 ↓</p> <p>Serie 38.0 Total 176.0</p>

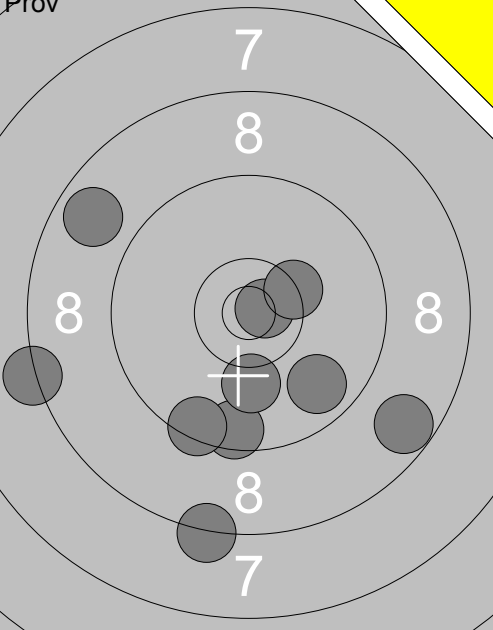
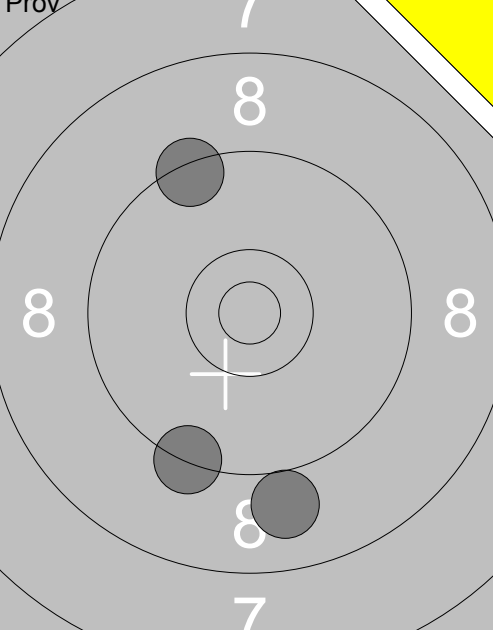
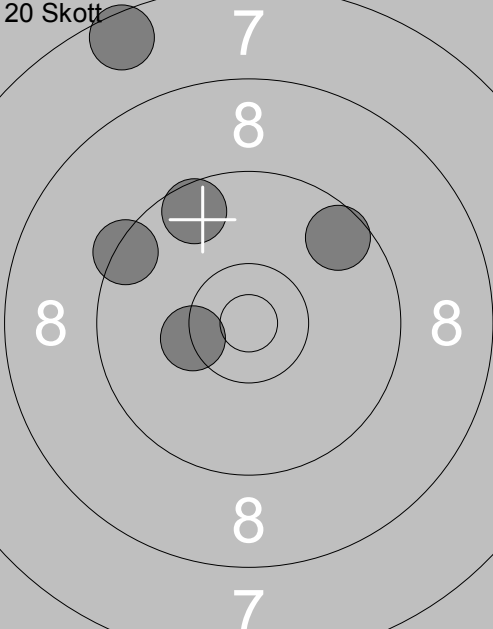
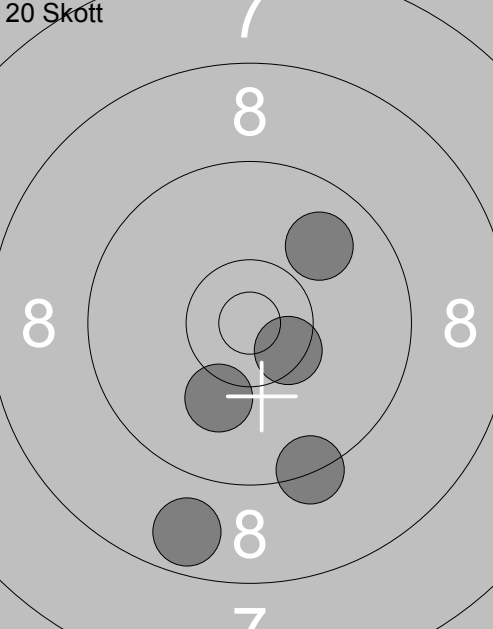
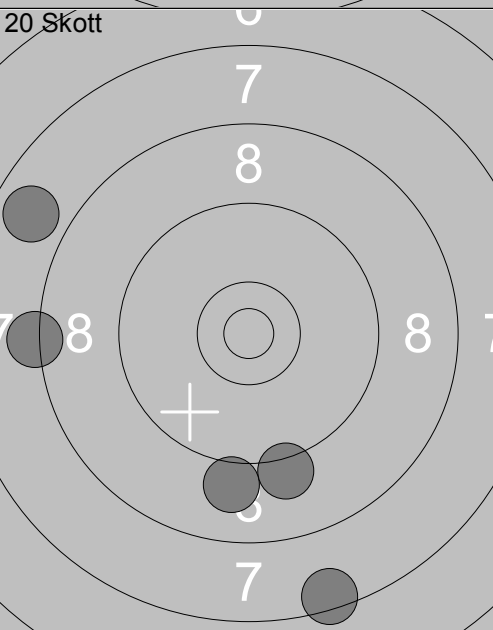
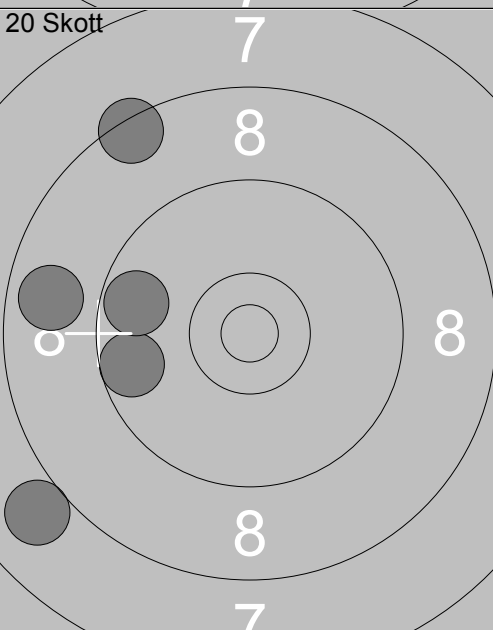
<p>Prov</p> 	<p>1: 9.5 ↓ 2: 10.1 ↓ 3: 8.7 ↘ 4: 8.8 ↖ 5: 9.8 ↘ 6: 8.3 ↓ 7: 9.5 ↓ 8: 10.8x → 9: 10.3x → 10: 8.3 ←</p> <p>Serie 89.0 Total 0.0</p>	<p>Prov</p> 	<p>11: 9.3 ↓ 12: 9.0 ↓ 13: 9.4 ↗</p> <p>Serie 27.0 Total 0.0</p>
<p>20 Skott</p> 	<p>1: 9.6 ↗ 2: 7.6 ↗ 3: 9.6 ↗ 4: 9.4 ↖ 5: 10.3x ←</p> <p>Serie 44.0 Total 44.0</p>	<p>20 Skott</p> 	<p>6: 9.9 ↗ 7: 10.5x ↘ 8: 10.1 ↓ 9: 8.7 ↓ 10: 9.3 ↓</p> <p>Serie 46.0 Total 90.0</p>
<p>20 Skott</p> 	<p>11: 8.2 ← 12: 9.0 ↓ 13: 9.1 ↓ 14: 7.8 ↖ 15: 7.5 ↓</p> <p>Serie 40.0 Total 130.0</p>	<p>20 Skott</p> 	<p>16: 8.0 ↖ 17: 8.4 ↖ 18: 9.6 ← 19: 8.8 ← 20: 9.7 ←</p> <p>Serie 42.0 Total 172.0</p>

	<p>1: 9.6 ↓ 2: 7.6 ↓ 3: 9.7 ↓ 4: 9.6 ↓ 5: 8.8 ↑ 6: 10.6x ↘ 7: 9.4 ↗ 8: 8.5 ↖ 9: 8.6 ↗ 10: 10.2 ↑</p> <p>Serie 87.0 Total 0.0</p>		<p>11: 9.5 ↓ 12: 9.4 ↓</p> <p>Serie 18.0 Total 0.0</p>
<p>20 Skott</p>	<p>1: 10.4x ↘ 2: 9.3 → 3: 9.5 ↙ 4: 9.8 ↙ 5: 7.6 ↓</p> <p>Serie 44.0 Total 44.0</p>	<p>20 Skott</p>	<p>6: 9.8 ↘ 7: 10.0 ↓ 8: 8.9 ↓ 9: 9.8 ↙ 10: 9.9 ↓</p> <p>Serie 45.0 Total 89.0</p>
<p>20 Skott</p>	<p>11: 7.1 ↑ 12: 7.7 ↘ 13: 5.5 → 14: 5.8 → 15: 5.9 →</p> <p>Serie 29.0 Total 118.0</p>	<p>20 Skott</p>	<p>16: 8.0 ↖ 17: 10.3 → 18: 9.9 ↗ 19: 10.1 ↗ 20: 8.4 ↗</p> <p>Serie 45.0 Total 163.0</p>

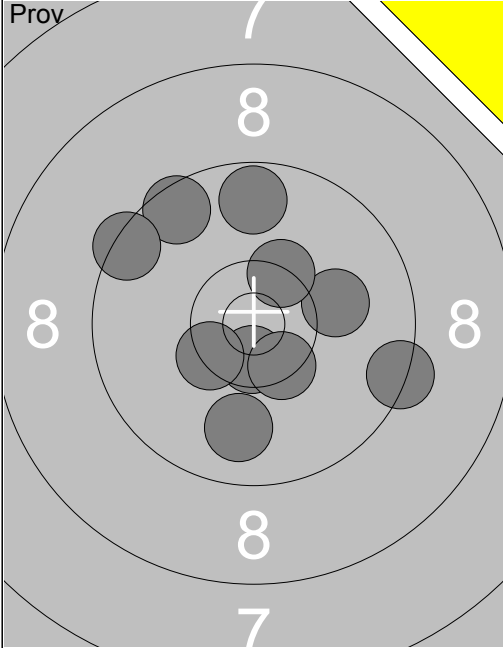
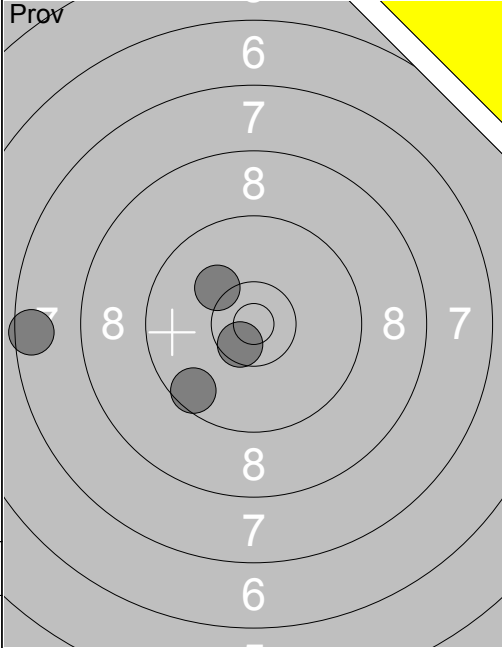
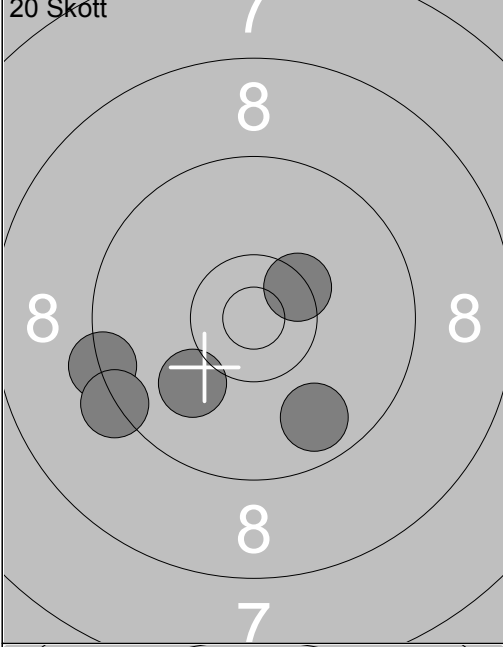
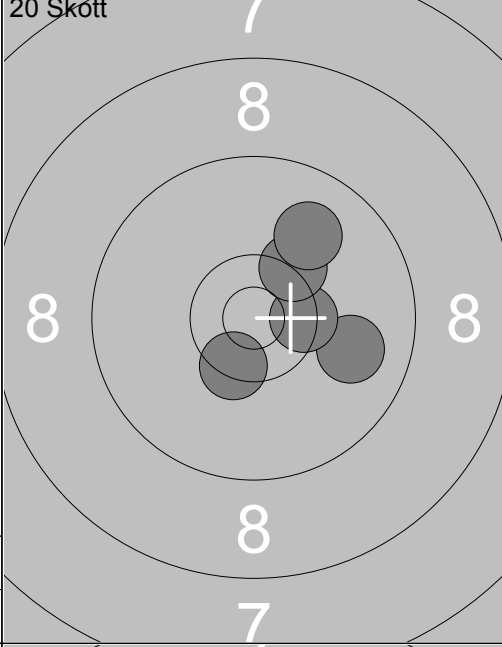
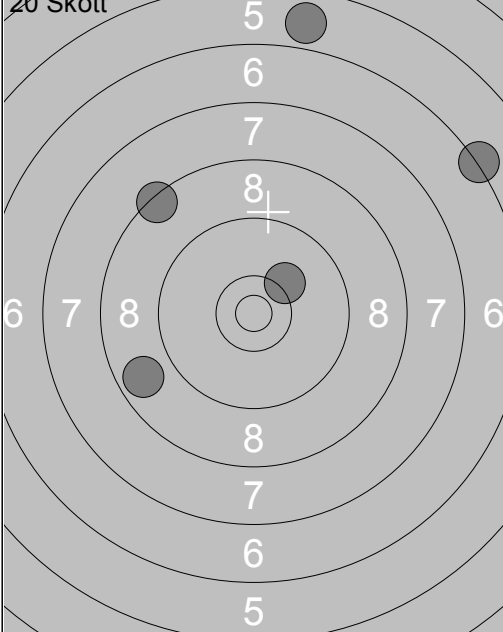
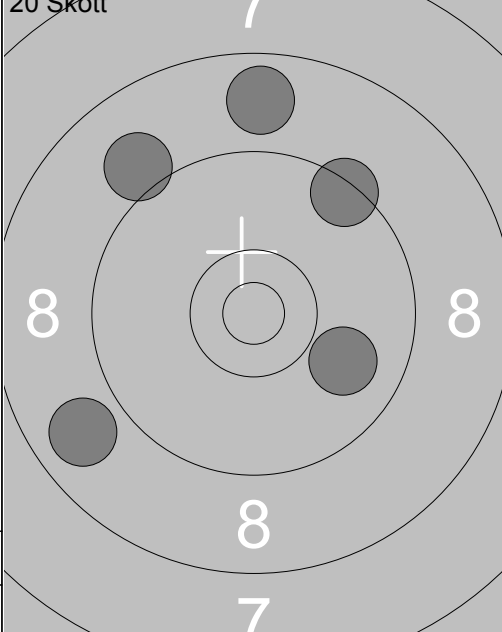
Skjuttag	Tavla	Andreas Edin			
4	14	Ale		Sen-S	No
11.07.2017	Tavelträffen Korthåll 2017		Ramselefors SKF		
Prov		1: 10.1 → 2: 10.4x ↗ 3: 9.7 ↑ 4: 10.6x ↓ 5: 9.9 ↓ 6: 9.4 → 7: 10.4x ↘ 8: 10.4x ↘ 9: 9.5 ↗ 10: 9.4 ↖	Prov		11: 7.5 ← 12: 10.2 ↖ 13: 9.6 ↘ 14: 10.6x ↘
		Serie 95.0		Serie 36.0	
		Total 0.0		Total 0.0	
20 Skott		1: 9.3 ← 2: 10.4x ↗ 3: 9.3 ← 4: 10.0 ↘ 5: 9.8 ↓	20 Skott		6: 9.9 ⇒ 7: 10.4x ⇒ 8: 10.4x ↘ 9: 10.3x ↗ 10: 9.9 ↗
		Serie 47.0		Serie 48.0	
		Total 47.0		Total 95.0	
20 Skott		11: 5.9 ↑ 12: 6.3 ↗ 13: 10.2 ↗ 14: 8.4 ↖ 15: 8.7 ↖	20 Skott		16: 9.0 ↖ 17: 8.8 ↑ 18: 9.4 ↗ 19: 8.8 ↖ 20: 9.9 ⇒
		Serie 37.0		Serie 43.0	
		Total 132.0		Total 175.0	

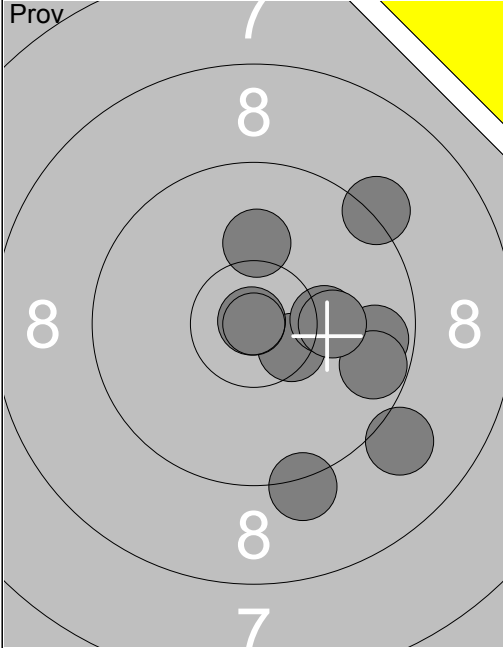
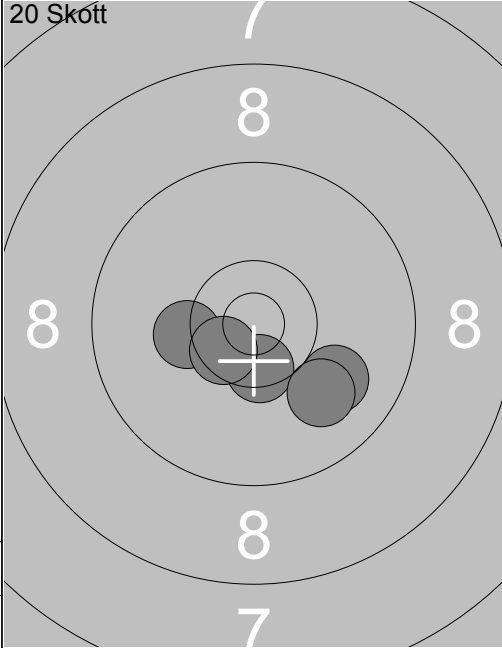
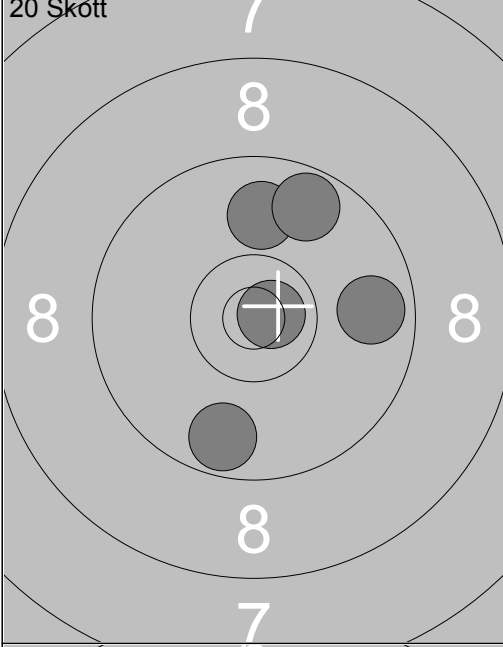
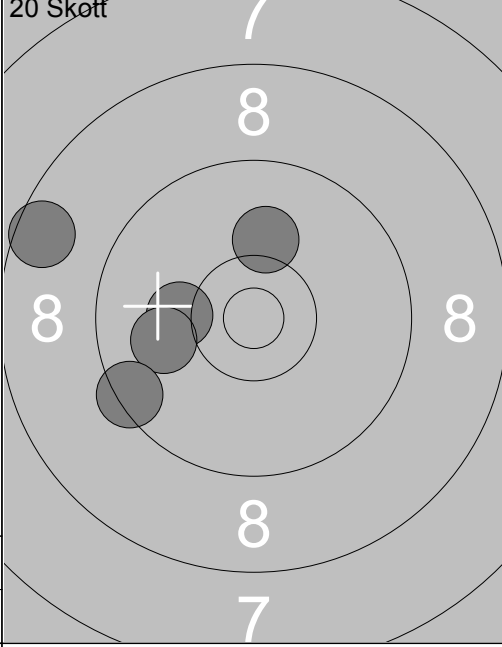
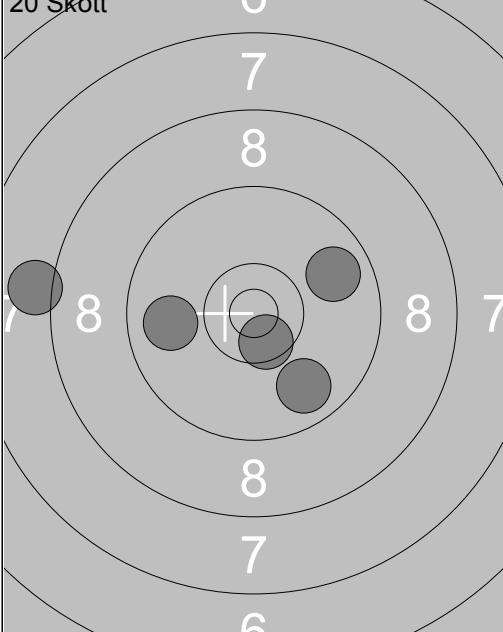
Skjuttag 4	Tavla 15	Fanny Storm			
Vindeln	Hogdal	Jun-S	Jä		
11.07.2017	Tavelträffen Korthåll 2017	Ramselefors SKF			
Prov		1: 10.5x ↘ 2: 9.7 → 3: 9.7 → 4: 9.2 ↗ 5: 9.0 ↘ 6: 10.1 ↑ 7: 9.2 ↓ 8: 10.2 → 9: 10.2 → 10: 10.9x ↘	20 Skott		1: 9.9 ↘ 2: 10.5x ↓ 3: 10.3 ← 4: 10.5x ↘ 5: 10.0 ↘
		Serie 95.0			Serie 49.0
		Total 0.0			Total 49.0
20 Skott		6: 9.9 ↑ 7: 10.8x → 8: 9.7 ↓ 9: 9.7 ↗ 10: 9.8 →	20 Skott		11: 10.1 ↑ 12: 8.6 ↙ 13: 10.2 ← 14: 10.0 ← 15: 9.4 ↙
		Serie 46.0			Serie 47.0
		Total 95.0			Total 142.0
20 Skott		16: 8.1 ← 17: 9.8 ↘ 18: 9.8 ↗ 19: 10.5x ↓ 20: 9.9 ←			
		Serie 45.0			
		Total 187.0			

<p>Prov</p>	<p>20 Skott</p>	<table style="width:100%; border-collapse: collapse;"> <tr><td>1: 8.5</td><td>←</td></tr> <tr><td>2: 9.4</td><td>↓</td></tr> <tr><td>3: 10.0</td><td>↓</td></tr> <tr><td>4: 9.9</td><td>↓</td></tr> <tr><td>5: 9.5</td><td>→</td></tr> <tr><td>6: 10.3x</td><td>↗</td></tr> <tr><td>7: 9.8</td><td>↓</td></tr> <tr><td>8: 10.0</td><td>↖</td></tr> </table>	1: 8.5	←	2: 9.4	↓	3: 10.0	↓	4: 9.9	↓	5: 9.5	→	6: 10.3x	↗	7: 9.8	↓	8: 10.0	↖
1: 8.5	←																	
2: 9.4	↓																	
3: 10.0	↓																	
4: 9.9	↓																	
5: 9.5	→																	
6: 10.3x	↗																	
7: 9.8	↓																	
8: 10.0	↖																	
Serie 74.0	Serie 46.0																	
Total 0.0	Total 46.0																	

<p>20 Skott</p>	<p>20 Skott</p>	<table style="width:100%; border-collapse: collapse;"> <tr><td>6: 10.2</td><td>↖</td></tr> <tr><td>7: 10.5x</td><td>↖</td></tr> <tr><td>8: 9.3</td><td>↑</td></tr> <tr><td>9: 9.4</td><td>↖</td></tr> <tr><td>10: 10.4x</td><td>↗</td></tr> </table>	6: 10.2	↖	7: 10.5x	↖	8: 9.3	↑	9: 9.4	↖	10: 10.4x	↗
6: 10.2	↖											
7: 10.5x	↖											
8: 9.3	↑											
9: 9.4	↖											
10: 10.4x	↗											
Serie 48.0	Serie 31.0											
Total 94.0	Total 125.0											

<p>20 Skott</p>	<table style="width:100%; border-collapse: collapse;"> <tr><td>16: 9.1</td><td>↖</td></tr> <tr><td>17: 9.1</td><td>↖</td></tr> <tr><td>18: 10.5x</td><td>↗</td></tr> <tr><td>19: 9.2</td><td>↓</td></tr> <tr><td>20: 8.6</td><td>↖</td></tr> </table>	16: 9.1	↖	17: 9.1	↖	18: 10.5x	↗	19: 9.2	↓	20: 8.6	↖	
16: 9.1	↖											
17: 9.1	↖											
18: 10.5x	↗											
19: 9.2	↓											
20: 8.6	↖											
Serie 45.0												
Total 170.0												

 <p style="text-align:center;">7</p>	<p>1: 9.4 ➔</p> <p>2: 10.1 ➔</p> <p>3: 9.7 ↙</p> <p>4: 9.0 ↖</p> <p>5: 9.9 ↑</p> <p>6: 9.0 ↓</p> <p>7: 9.0 ↗</p> <p>8: 9.8 ↖</p> <p>9: 9.5 ↖</p> <p>10: 8.3 ↑</p> <p>Serie 90.0</p> <p>Total 0.0</p>	 <p style="text-align:center;">7</p>	<p>11: 10.4x7</p> <p>Serie 10.0</p> <p>Total 0.0</p>
--	--	--	--

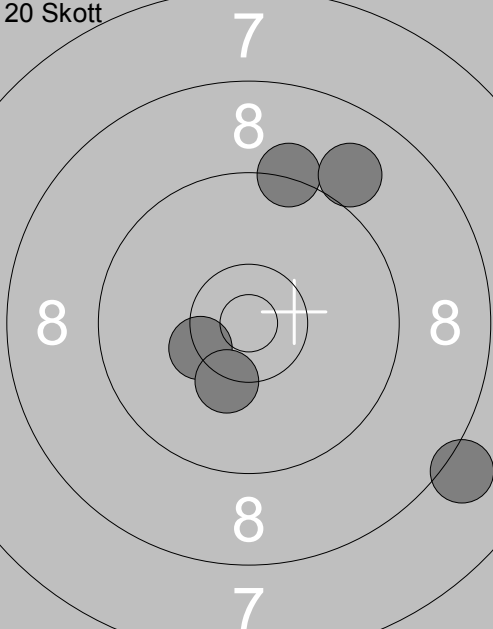
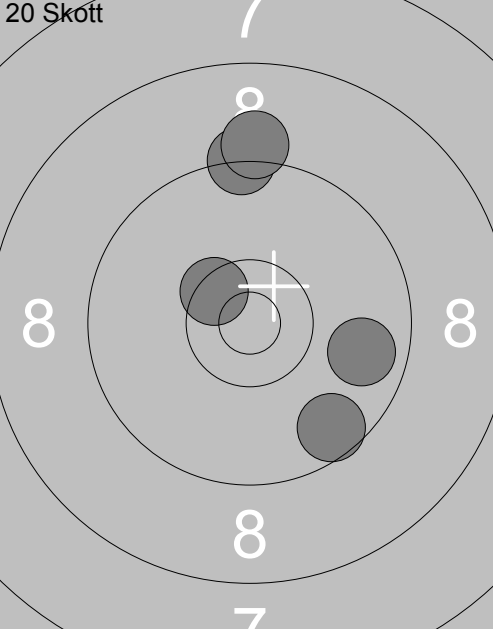
 <p style="text-align:center;">7</p>	<p>1: 10.4x</p> <p>2: 10.3 ↓</p> <p>3: 9.3 ↑</p> <p>4: 9.0 ↗</p> <p>5: 8.1 ➔</p> <p>Serie 46.0</p> <p>Total 46.0</p>	 <p style="text-align:center;">7</p>	<p>6: 9.8 ➔</p> <p>7: 9.3 ↑</p> <p>8: 9.6 ↓</p> <p>9: 10.5x</p> <p>10: 9.1 ↑</p> <p>Serie 46.0</p> <p>Total 92.0</p>
---	--	---	--

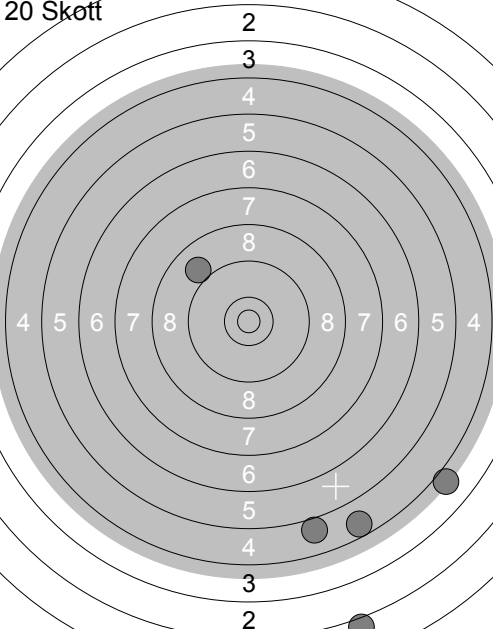
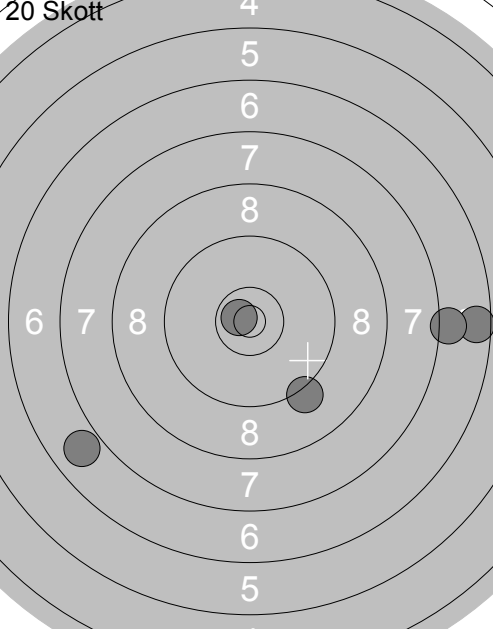
 <p style="text-align:center;">8</p>	<p>11: 4.0 ↘</p> <p>12: 2.1 ↓</p> <p>13: 9.0 ↗</p> <p>14: 5.0 ↓</p> <p>15: 4.7 ↓</p> <p>Serie 24.0</p> <p>Total 116.0</p>	 <p style="text-align:center;">8</p>	<p>16: 9.2 ↓</p> <p>17: 10.7x</p> <p>18: 6.6 ➔</p> <p>19: 7.1 ➔</p> <p>20: 6.9 ↙</p> <p>Serie 38.0</p> <p>Total 154.0</p>
--	---	--	---

	1: 8.3 ↑		11: 7.3 ↗
	2: 10.4 ↘		12: 9.8 →
	3: 8.6 ↗		13: 9.7 ↑
	4: 8.9 ↑		14: 8.6 ↓
	5: 9.9 ↘		15: 9.4 ↑
	6: 10.3 ↙		
	7: 9.4 ←		
	8: 9.7 ↓		
	9: 9.1 ↗		
	10: 10.2 ←		
Serie 90.0		Serie 42.0	
Total 0.0		Total 0.0	

	1: 9.6 ↑		6: 9.7 ↑
	2: 10.2 →		7: 10.2 ↑
	3: 9.3 ←		8: 10.1 ←
	4: 9.2 ↗		9: 9.1 ←
	5: 10.0 ↗		10: 6.5 ←
Serie 47.0		Serie 44.0	
Total 47.0		Total 91.0	

	11: 5.0 ↓		16: 8.7 ↑
	12: 5.2 ↓		17: 5.5 ↘
	13: 7.2 ←		18: 7.5 →
	14: 7.0 ↑		19: 6.8 ↗
	15: 7.1 ↘		20: 8.4 ↙
Serie 31.0		Serie 34.0	
Total 122.0		Total 156.0	

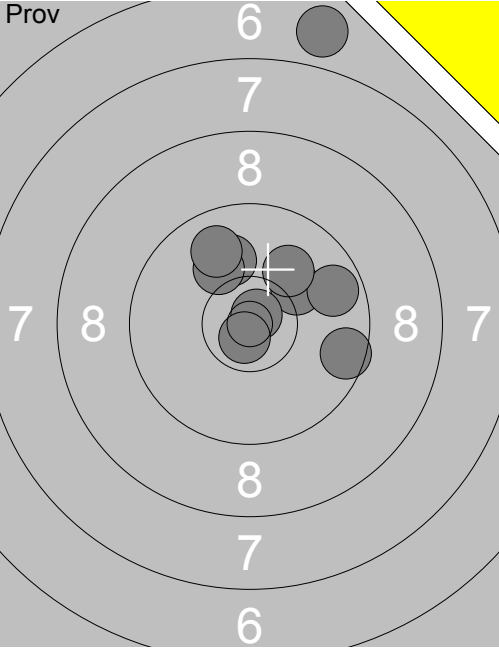
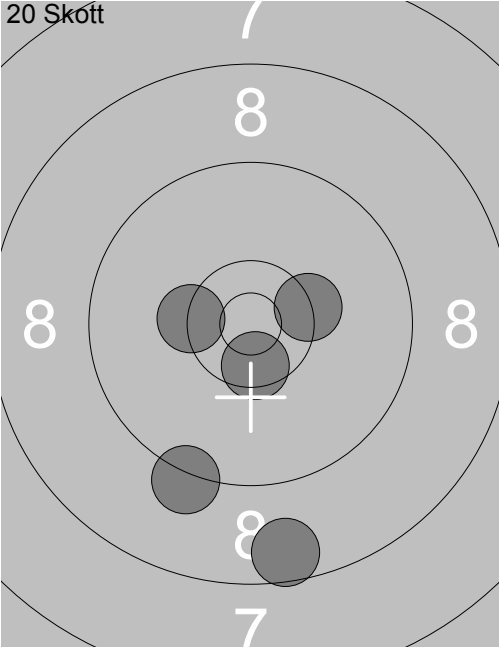
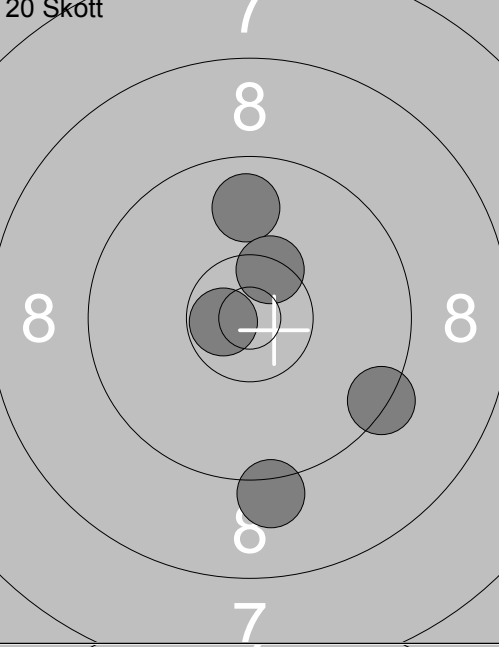
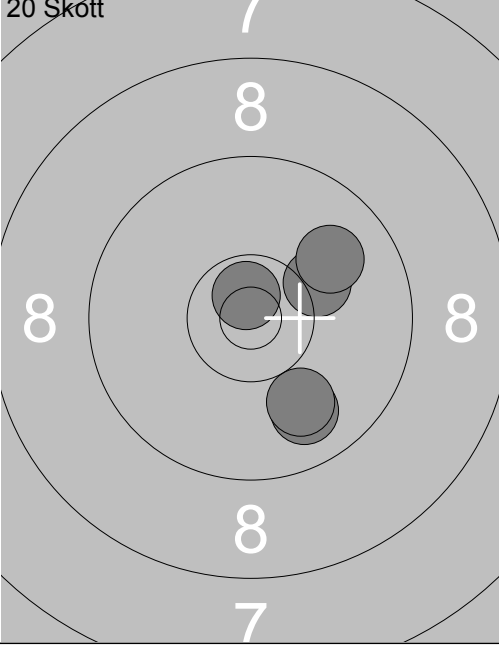
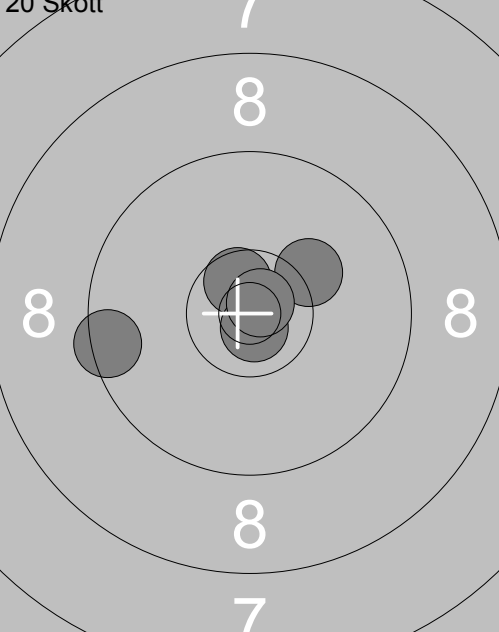
Skjuttag	Tavla	Håkan Lidman			
Vindeln	Piteå	Vet-L		No	
11.07.2017	Tavelträffen Korthåll 2017	Ramselefors SKF			
Prov 	1: 6.8 ↑	20 Skott 	1: 9.2 ↓		
	2: 10.1 ↗		2: 10.3x➤		
	3: 9.7 ➔		3: 8.6 ↓		
	4: 10.1 ↗		4: 10.3x➤		
	5: 10.8x↗		5: 10.5x↓		
	6: 9.6 ➔				
	7: 10.0 ↑				
	8: 10.1 ↖				
	9: 9.9 ↖				
	10: 10.7x↓				
	Serie 93.0		Serie 47.0		
	Total 0.0		Total 47.0		
20 Skott 	6: 9.8 ↑	20 Skott 	11: 10.2 ↗		
	7: 10.7x➤		12: 9.9 ↗		
	8: 10.4x↗		13: 10.7x↗		
	9: 9.4 ➔		14: 9.9 ↓		
	10: 9.1 ↓		15: 10.0 ↓		
	Serie 47.0		Serie 48.0		
	Total 94.0		Total 142.0		
20 Skott 	16: 9.5 ←				
	17: 10.6x↗				
	18: 10.2 ↗				
	19: 10.8x↓				
	20: 10.8x↗				
	Serie 49.0				
	Total 191.0				

<p>Prov</p>	<p>1: 9.9 ↘ 2: 10.2 ↙ 3: 9.8 ↓ 4: 10.5x ↗ 5: 10.0 ← 6: 10.8x ↑ 7: 9.5 → 8: 9.6 ↖ 9: 10.8x ↓ 10: 10.8x →</p> <p>Serie 96.0 Total 0.0</p>	<p>Prov</p>	<p>11: 9.6 ←</p> <p>Serie 9.0 Total 0.0</p>
<p>20 Skott</p>	<p>1: 9.8 ↙ 2: 9.6 ↘ 3: 9.5 ← 4: 9.9 ← 5: 10.2 ↘</p> <p>Serie 46.0 Total 46.0</p>	<p>20 Skott</p>	<p>6: 9.7 ↑ 7: 10.3x ↑ 8: 10.2 ↗ 9: 9.8 → 10: 9.4 →</p> <p>Serie 47.0 Total 93.0</p>
<p>20 Skott</p>	<p>11: 6.5 ↙ 12: 5.4 → 13: 4.2 ← 14: 8.4 → 15: 6.5 →</p> <p>Serie 29.0 Total 122.0</p>	<p>20 Skott</p>	<p>16: 8.0 ↖ 17: 10.3 ↙ 18: 9.6 ← 19: 10.0 → 20: 8.4 ↗</p> <p>Serie 45.0 Total 167.0</p>

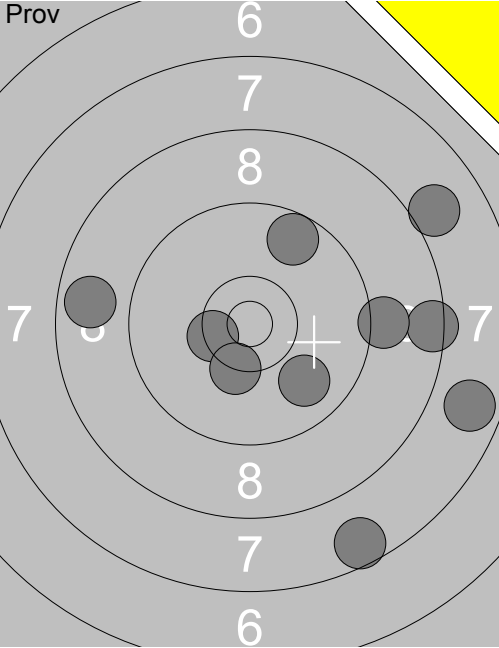
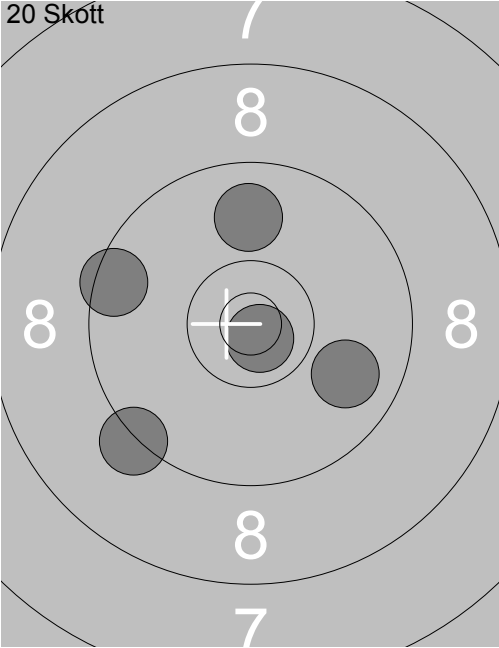
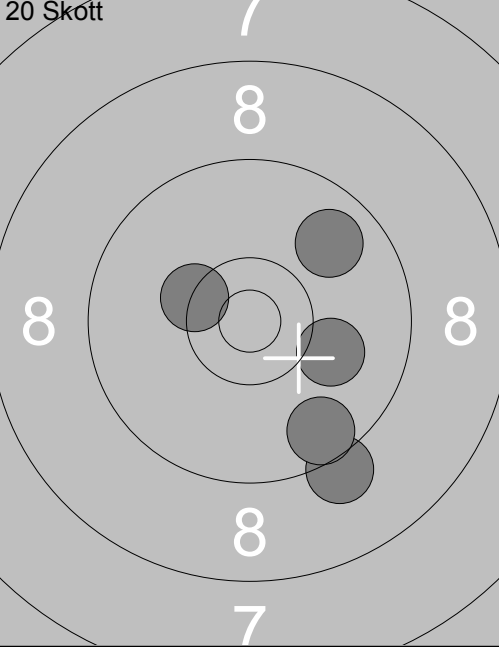
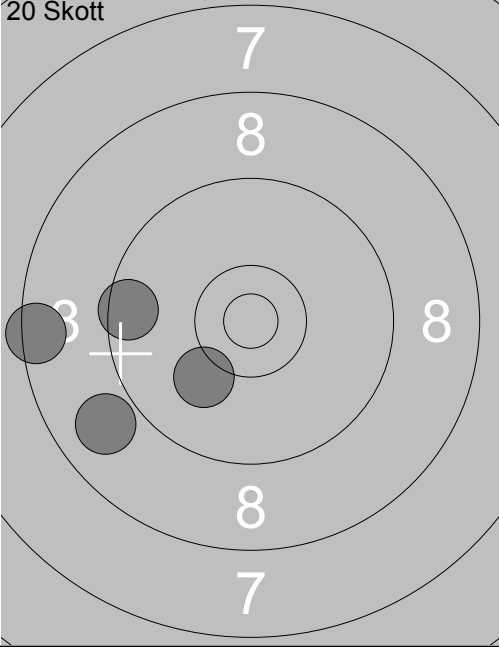
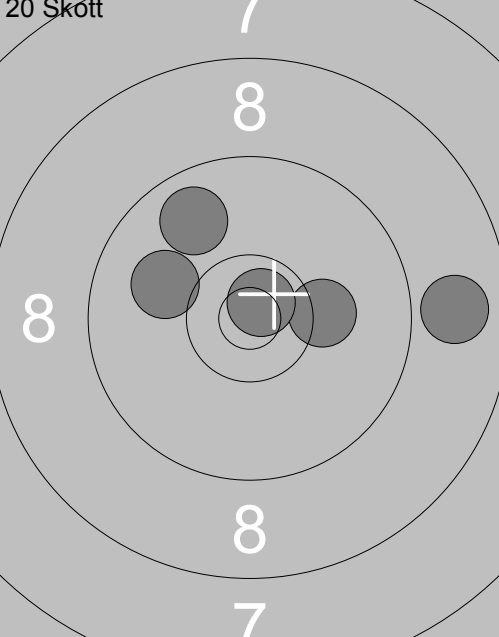
Skjutlag	Tavla	Ulf Enoksson			
4	21	Vindeln	Luleå	Vet-L	No
11.07.2017	Tavelträffen Korthåll 2017	Ramselefors SKF			
Prov		1: 7.6 ↘ 2: 8.0 ↗ 3: 7.8 → 4: 8.8 ← 5: 8.4 → 6: 10.4x↙ 7: 10.3x↘ 8: 9.9 ↘ 9: 9.1 → 10: 9.6 ↗	20 Skott		1: 9.3 ↙ 2: 9.9 ↘ 3: 9.5 ← 4: 10.8x↘ 5: 9.9 ↑
		Serie 85.0 Total 0.0		Serie 46.0 Total 46.0	
20 Skott		6: 9.2 ↘ 7: 10.1 → 8: 9.6 ↘ 9: 10.3x↙ 10: 9.8 ↗	20 Skott		11: 8.9 ↙ 12: 0.0 13: 9.5 ← 14: 10.1 ↘ 15: 8.5 ←
		Serie 47.0 Total 93.0		Serie 35.0 Total 128.0	
20 Skott		16: 10.2 → 17: 8.9 → 18: 10.0 ↙ 19: 9.8 ↗ 20: 10.8x↗			
		Serie 47.0 Total 175.0			

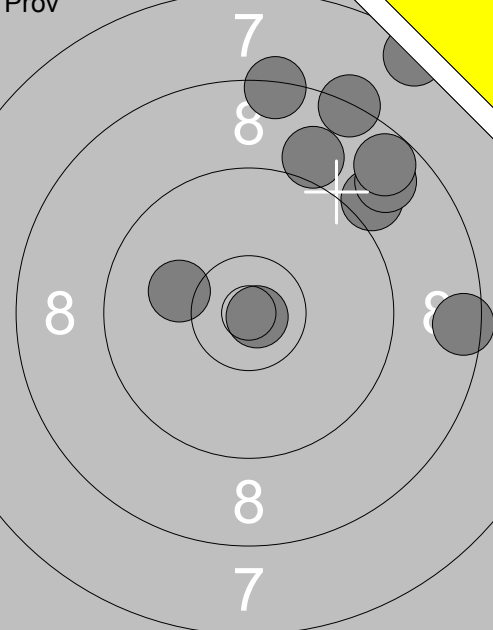
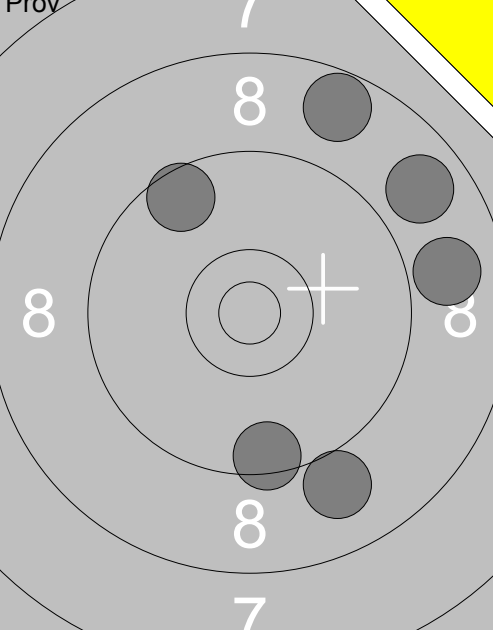
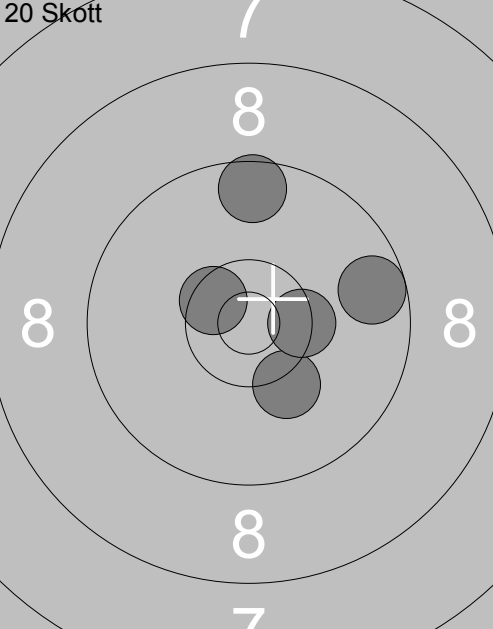
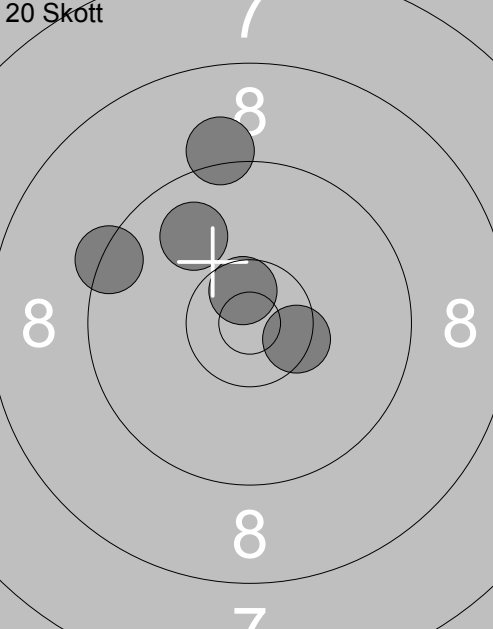
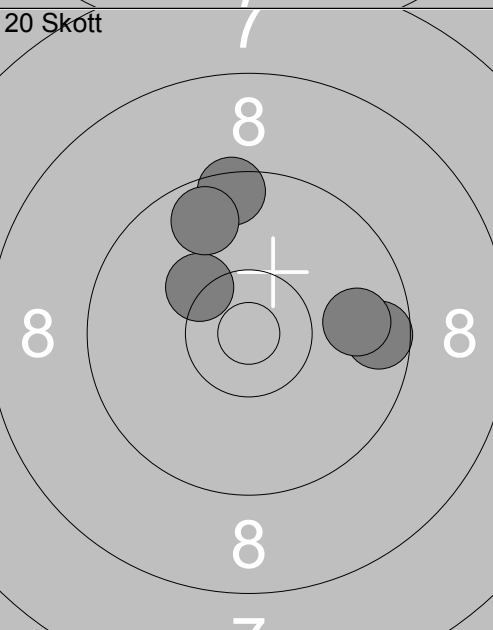
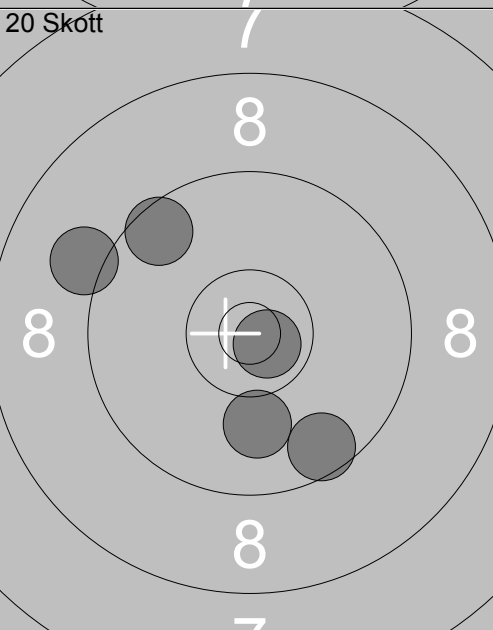
 <p style="text-align: center;">7 8 8 8 7</p>	<p>1: 7.5 ↗ 2: 9.0 ↗ 3: 9.0 ↗ 4: 8.3 ↗ 5: 8.8 ↗ 6: 10.8x ➤ 7: 8.5 → 8: 8.7 ↗ 9: 8.4 ↗ 10: 10.1 ←</p> <p>Serie 85.0 Total 0.0</p>	 <p style="text-align: center;">7 8 8 8 7</p>	<p>11: 8.7 ↗ 12: 8.8 ↗ 13: 9.5 ↓ 14: 8.9 → 15: 9.0 ↓ 16: 9.6 ↗</p> <p>Serie 51.0 Total 0.0</p>
<p>20 Skott</p>  <p style="text-align: center;">7 8 8 8 7</p>	<p>1: 10.2 ↓ 2: 9.7 → 3: 10.4x ➤ 4: 9.6 ↗ 5: 10.5x ➤</p> <p>Serie 48.0 Total 48.0</p>	<p>20 Skott</p>  <p style="text-align: center;">7 8 8 8 7</p>	<p>6: 9.9 ↗ 7: 10.6x ↗ 8: 9.4 ← 9: 9.2 ↗ 10: 10.4x ➤</p> <p>Serie 47.0 Total 95.0</p>
<p>20 Skott</p>  <p style="text-align: center;">7 8 8 8 7</p>	<p>11: 10.3 ↗ 12: 9.5 ↗ 13: 9.6 → 14: 9.8 → 15: 9.7 ↗</p> <p>Serie 46.0 Total 141.0</p>	<p>20 Skott</p>  <p style="text-align: center;">7 8 8 8 7</p>	<p>16: 10.0 ↓ 17: 9.6 ↗ 18: 10.7x ➤ 19: 9.1 ← 20: 9.6 ↓</p> <p>Serie 47.0 Total 188.0</p>

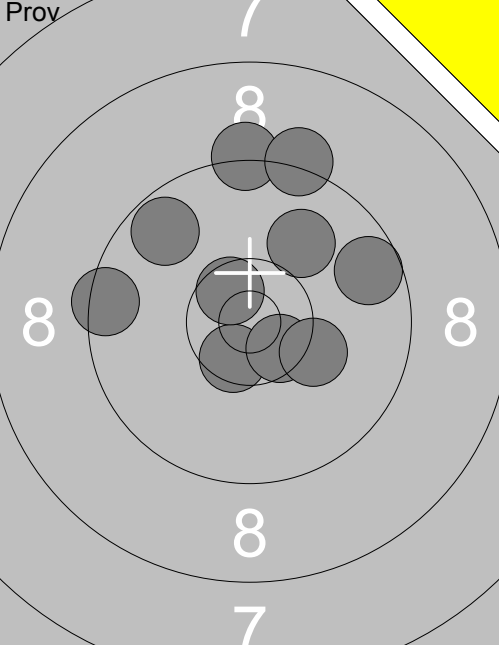
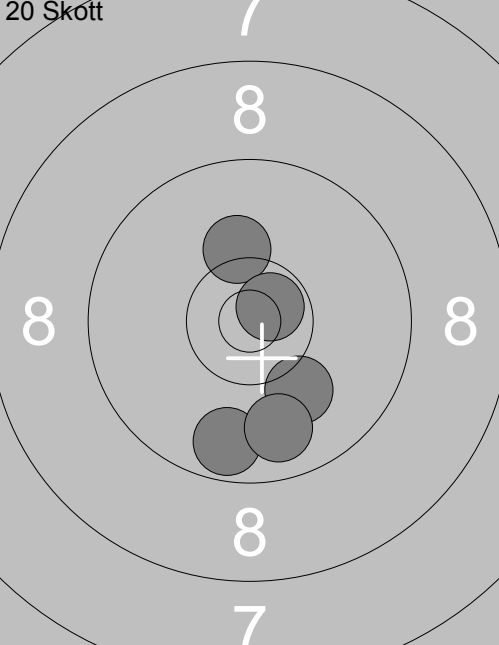
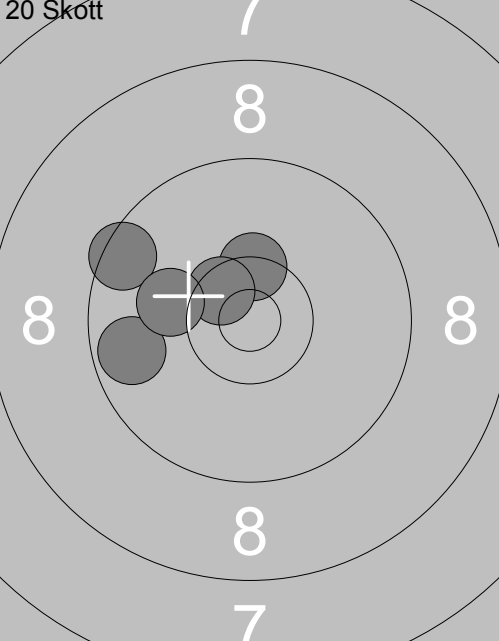
Skjutlag	Tavla	Niklas Johansson										
4	23	Ramselefors		Sen-L	Vb							
11.07.2017		Tavelträffen Korthåll 2017		Ramselefors SKF								
Prov		1: 10.5x ↘	2: 9.3 ↑	3: 10.0 ↗	4: 9.2 ↑	5: 10.5x ↘	6: 9.6 →	7: 9.7 ↖	8: 9.5 ←	9: 10.6x ↘	10: 10.2 →	11: 10.0 ↑
		Serie 95.0		Serie 10.0		Total 0.0		Total 0.0				
20 Skott		1: 10.2 ↑	2: 10.1 ↘	3: 9.7 ↓	4: 9.8 ↓	5: 10.7x ↗	6: 10.0 ↓	7: 9.4 ←	8: 9.3 ↖	9: 9.9 ↖	10: 10.6x ↘	
		Serie 48.0		Serie 47.0		Total 48.0		Total 95.0				
20 Skott		11: 10.4x ↑	12: 9.5 ↖	13: 9.7 ←	14: 10.5x ↘	15: 10.1 ←	16: 10.2 ↖	17: 10.2 ↘	18: 9.4 ↓	19: 10.1 ↓	20: 9.2 ←	
		Serie 48.0		Serie 48.0		Total 143.0		Total 191.0				

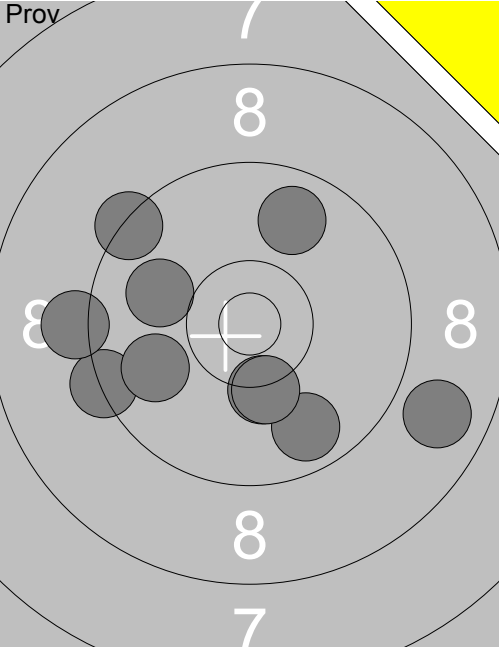
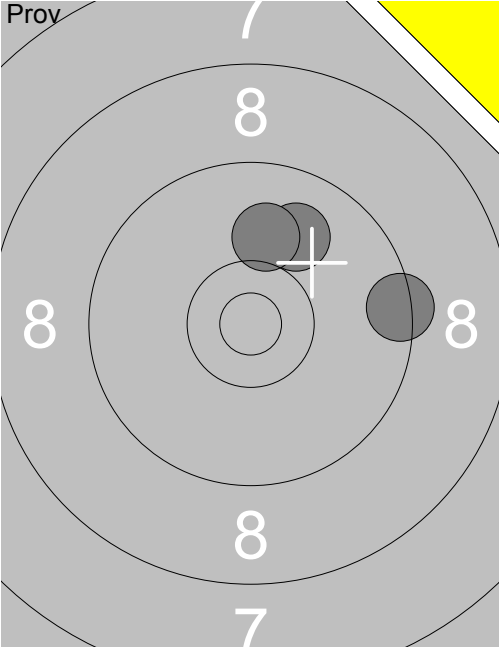
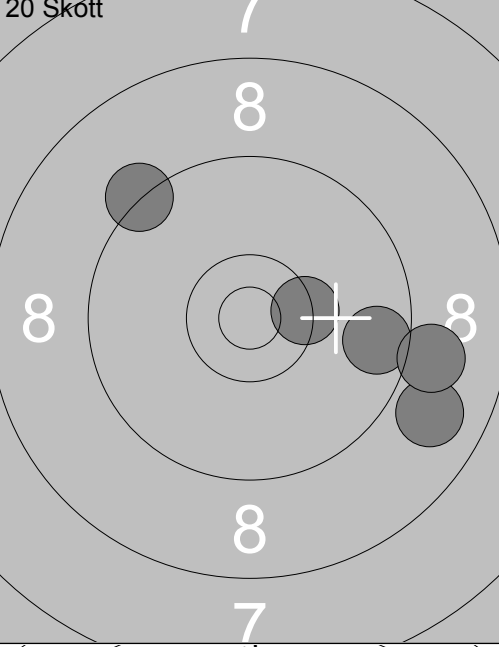
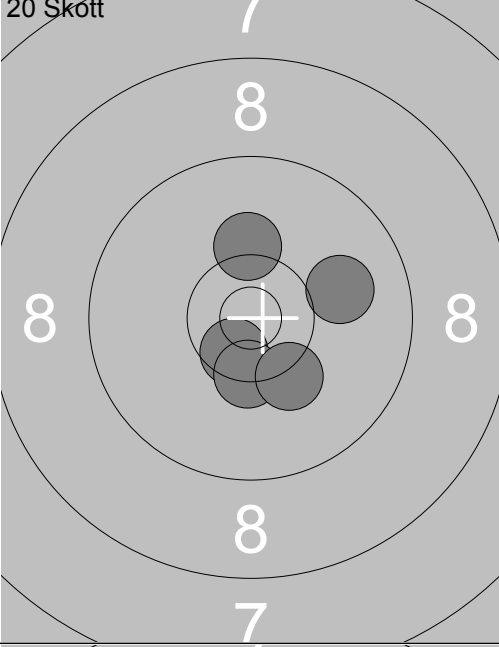
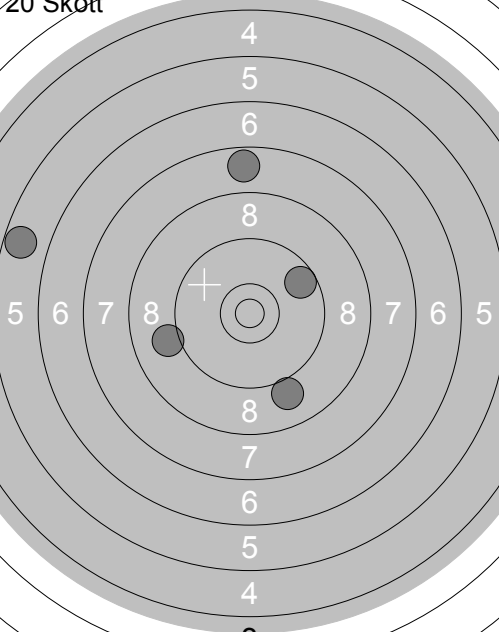
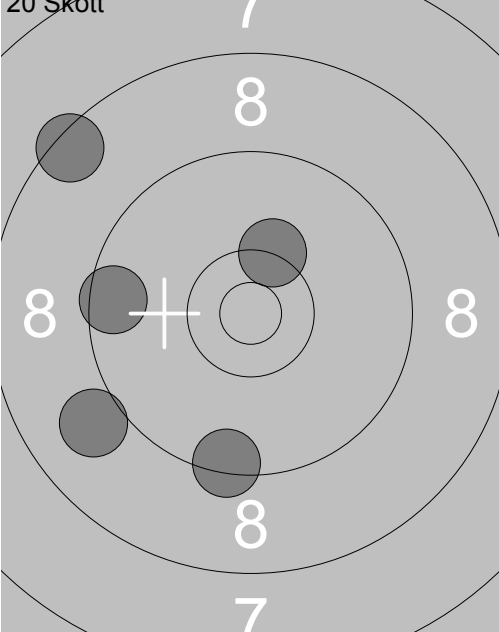
Skjuttag	Tavla	Johny Vadebo			
4	24	Helsingborg		Vet-S	Sk
11.07.2017		Tavelträffen Korthåll 2017		Ramselefors SKF	
Prov 	1: 9.3 ←	Prov 	11: 9.4 →		
	2: 9.2 ←		12: 10.0 ↗		
	3: 8.8 ↘		13: 10.1 ↗		
	4: 10.3 ↓				
	5: 9.8 ↓				
	6: 10.3 ↓				
	7: 9.9 ←				
	8: 9.4 ↗				
	9: 9.8 ↗				
	10: 10.0 ←				
	Serie 92.0		Serie 29.0		
	Total 0.0		Total 0.0		
20 Skott 	1: 8.9 ↘	20 Skott 	6: 10.6x ↓		
	2: 9.6 →		7: 10.0 →		
	3: 9.3 ↗		8: 10.2 ↑		
	4: 9.1 →		9: 10.4x ↓		
	5: 10.4x →		10: 10.2 ↓		
	Serie 45.0		Serie 50.0		
	Total 45.0		Total 95.0		
20 Skott 	11: 9.0 ↓	20 Skott 	16: 9.4 ↓		
	12: 9.1 ←		17: 9.0 ←		
	13: 5.7 ←		18: 10.3x ↗		
	14: 7.7 ↑		19: 8.5 ↗		
	15: 9.7 ↗		20: 9.5 ←		
	Serie 39.0		Serie 45.0		
	Total 134.0		Total 179.0		

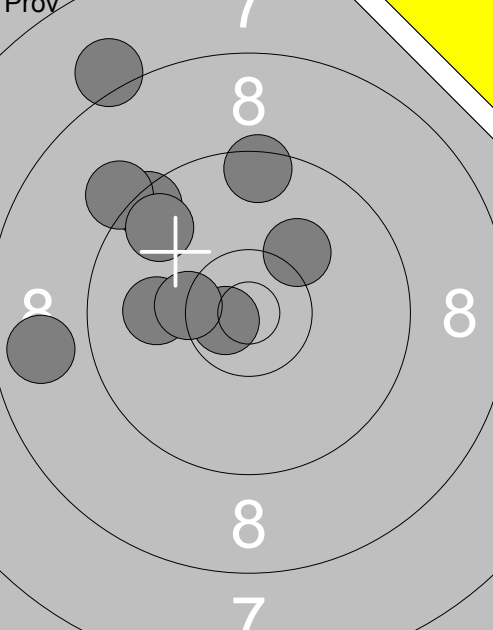
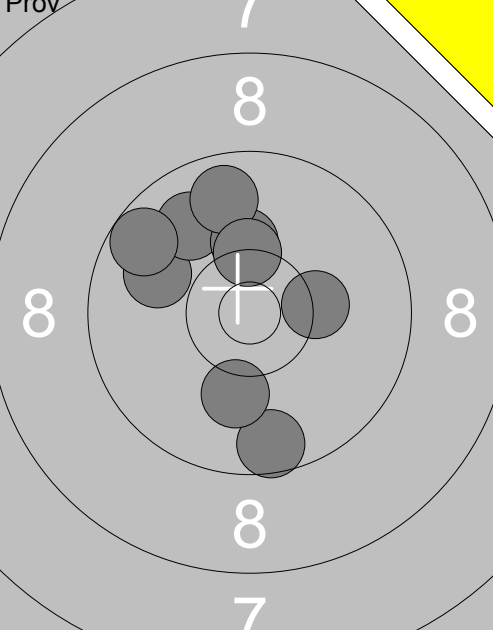
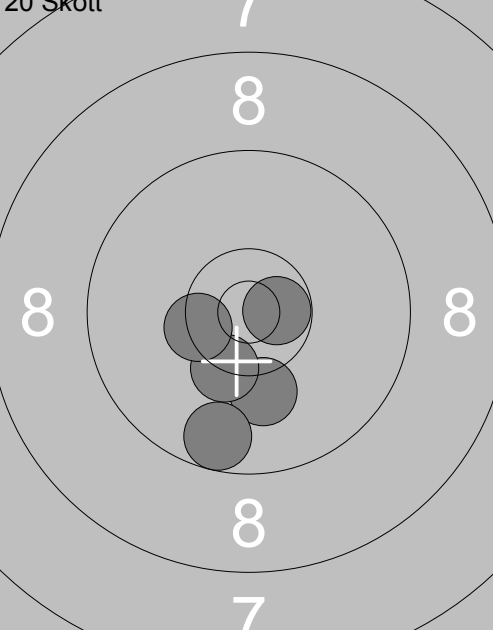
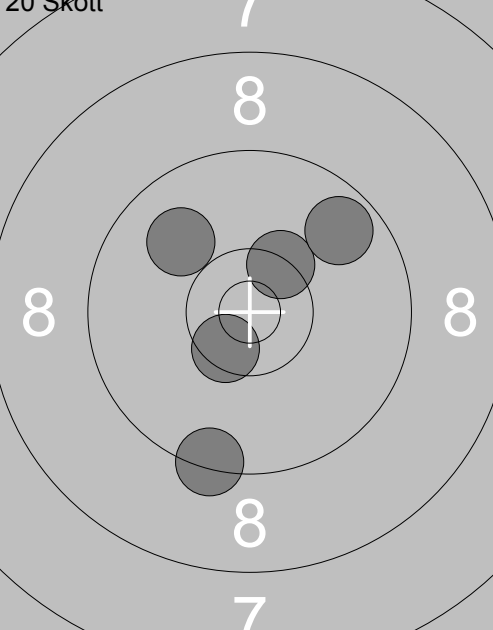
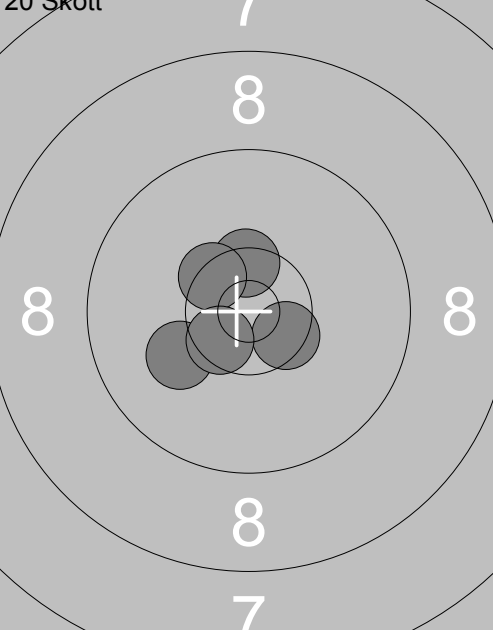
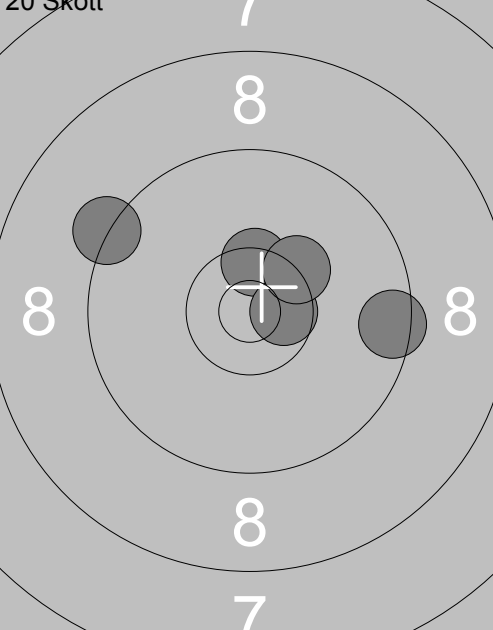
 <p style="text-align:center;">7 8 8 8</p>	<p>1: 9.5 ↖ 2: 8.1 ↖ 3: 9.5 ↑ 4: 9.2 ↖ 5: 10.7x↔ 6: 10.0← 7: 9.7 ↖ 8: 8.8 ← 9: 10.2 ↗ 10: 10.3x↔</p> <p>Serie 92.0 Total 0.0</p>	 <p style="text-align:center;">7 8 8 8</p>	<p>11: 9.9 ↖ 12: 9.9 ↖ 13: 10.2 ↑ 14: 9.7 ↖ 15: 9.8 ↑ 16: 10.3x↑ 17: 9.6 ↓ 18: 10.3→ 19: 10.1 ↓</p> <p>Serie 85.0 Total 0.0</p>
<p>20 Skott</p>  <p style="text-align:center;">7 8 8 8</p>	<p>1: 10.7x⇒ 2: 10.1 ↓ 3: 10.3x↘ 4: 10.4x↔ 5: 9.6 ↓</p> <p>Serie 49.0 Total 49.0</p>	<p>20 Skott</p>  <p style="text-align:center;">7 8 8 8</p>	<p>6: 9.4 ↓ 7: 10.5x↘ 8: 10.4x↗ 9: 9.9 ↖ 10: 9.7 ↗</p> <p>Serie 47.0 Total 96.0</p>
<p>20 Skott</p>  <p style="text-align:center;">7 8 8 8</p>	<p>11: 10.5x↘ 12: 10.5x↑ 13: 10.4x↘ 14: 10.1 ↖ 15: 10.5x↘</p> <p>Serie 50.0 Total 146.0</p>	<p>20 Skott</p>  <p style="text-align:center;">7 8 8 8</p>	<p>16: 10.4x↑ 17: 9.5 → 18: 10.6x⇒ 19: 10.3x↗ 20: 9.3 ↖</p> <p>Serie 48.0 Total 194.0</p>

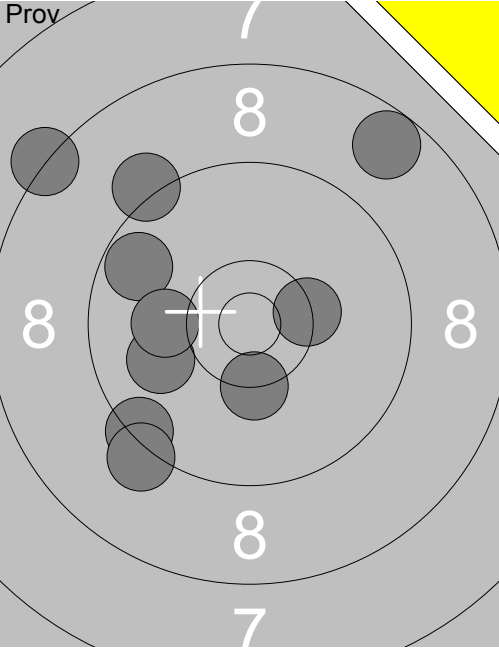
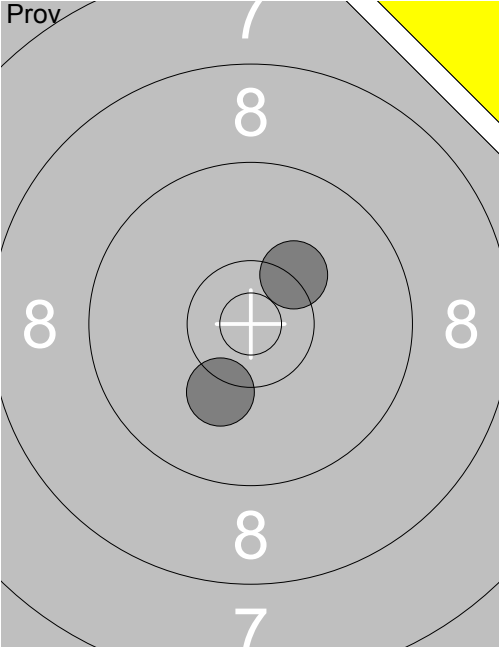
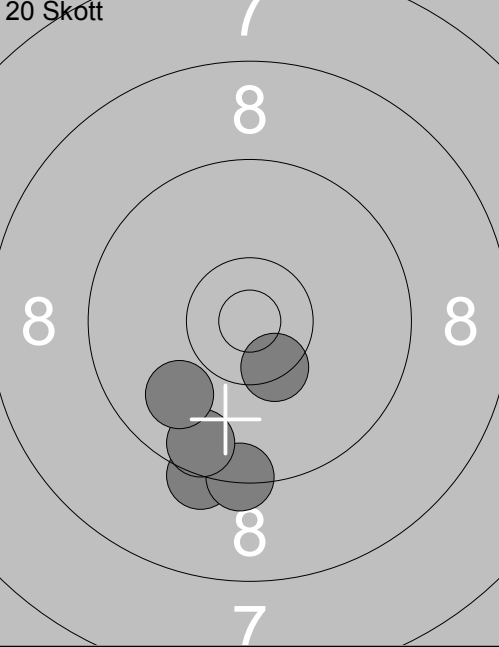
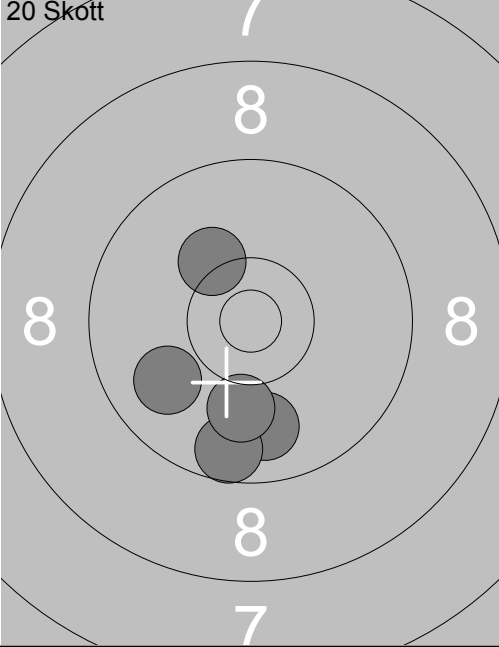
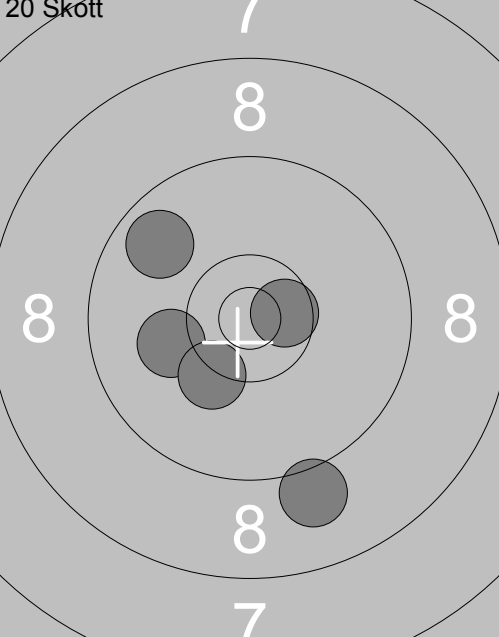
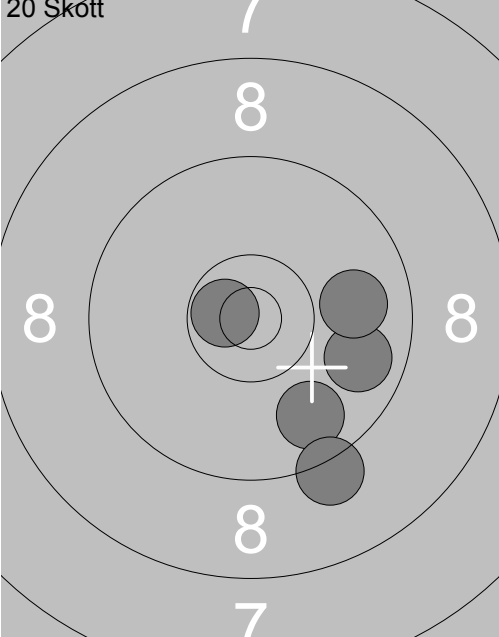
Skjuttag	Tavla	Jennifer Gustafsson			
5	2	Ramselefors		13	Vb
11.07.2017	Tavelträffen Korthåll 2017		Ramselefors SKF		
Prov		1: 8.7 ↗ 2: 8.3 ↖ 3: 9.2 ↖ 4: 9.4 ↘ 5: 10.4x→ 6: 10.3x↓ 7: 9.7 ↖ 8: 9.2 ↘ 9: 10.0↙ 10: 10.1↙	Prov		11: 10.2 ↘ 12: 10.3 ↗
		Serie 92.0		Serie 20.0	
		Total 0.0		Total 0.0	
20 Skott		1: 9.3 ↘ 2: 9.4 ↘ 3: 10.4x↓ 4: 9.6 ↘ 5: 9.9 ↘	20 Skott		6: 9.9 ↘ 7: 9.6 ↘ 8: 10.1 ↘ 9: 10.2 ↖ 10: 9.9 ↙
		Serie 46.0		Serie 47.0	
		Total 46.0		Total 93.0	
20 Skott		11: 9.8 ↖ 12: 10.1↙ 13: 10.3↘ 14: 9.1 ↘ 15: 10.6x→	20 Skott		16: 9.8 ↘ 17: 9.2 ↘ 18: 10.7x↖ 19: 9.8 → 20: 9.9 →
		Serie 48.0		Serie 46.0	
		Total 141.0		Total 187.0	

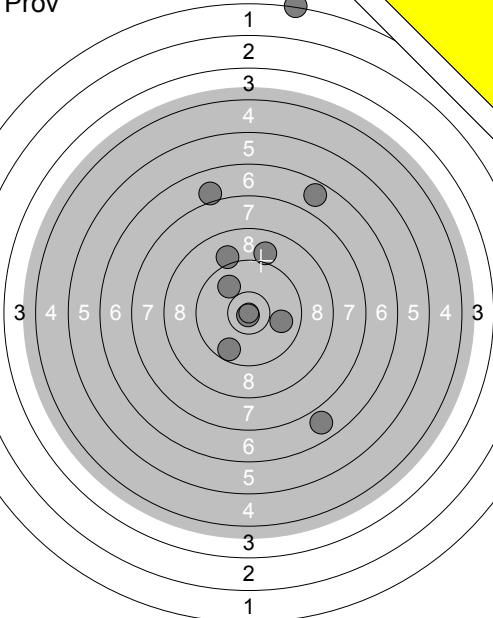
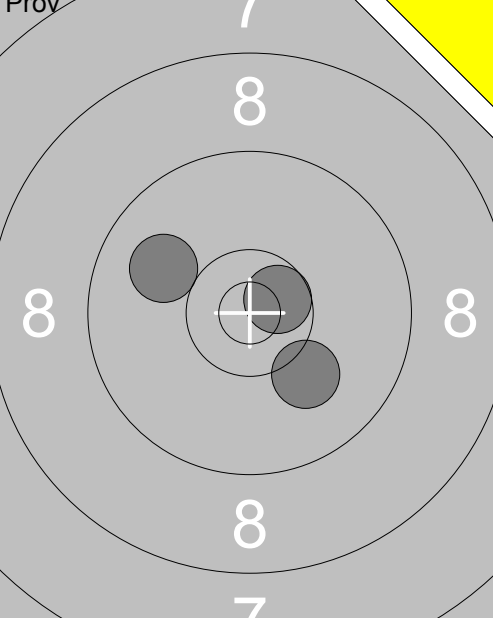
	<p>1: 1.3 ↑</p> <p>2: 6.7 ↗</p> <p>3: 7.0 ↑</p> <p>4: 6.8 ↓</p> <p>5: 10.9x↓</p> <p>6: 9.1 ↑</p> <p>7: 9.0 ↑</p> <p>8: 9.9 →</p> <p>9: 9.7 ↓</p> <p>10: 9.9 ↖</p>		<p>11: 10.1 ↓</p> <p>12: 10.6x↗</p> <p>13: 10.0 ↖</p>
Serie 75.0		Serie 30.0	
Total 0.0		Total 0.0	

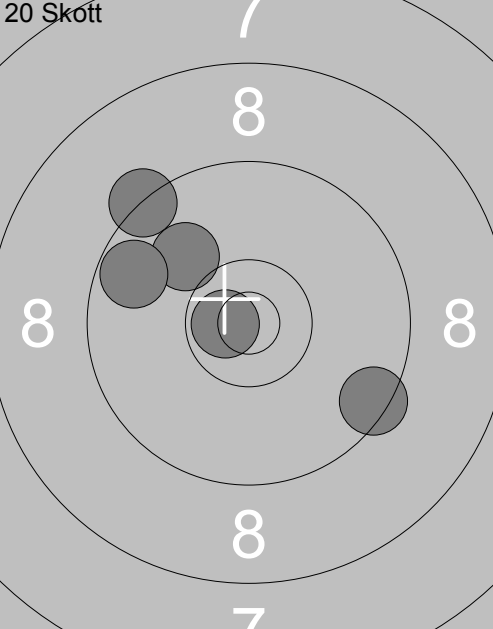
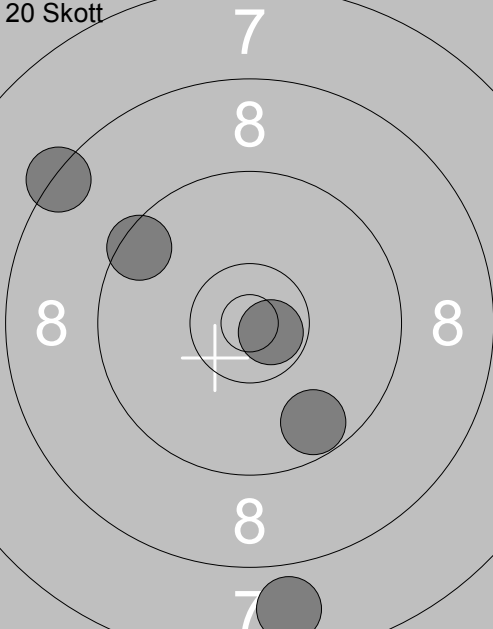
<p>20 Skott</p> 	<p>1: 9.3 ↖</p> <p>2: 10.0 ↖</p> <p>3: 9.7 ↖</p> <p>4: 10.7x↖</p> <p>5: 9.5 ↓</p>	<p>20 Skott</p> 	<p>6: 7.8 ↓</p> <p>7: 9.7 ↓</p> <p>8: 10.7x↗</p> <p>9: 8.4 ↗</p> <p>10: 9.5 ↖</p>
Serie 47.0		Serie 43.0	
Total 47.0		Total 90.0	

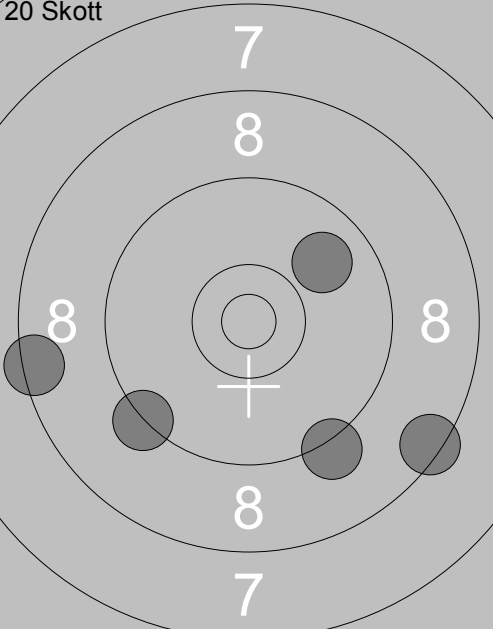
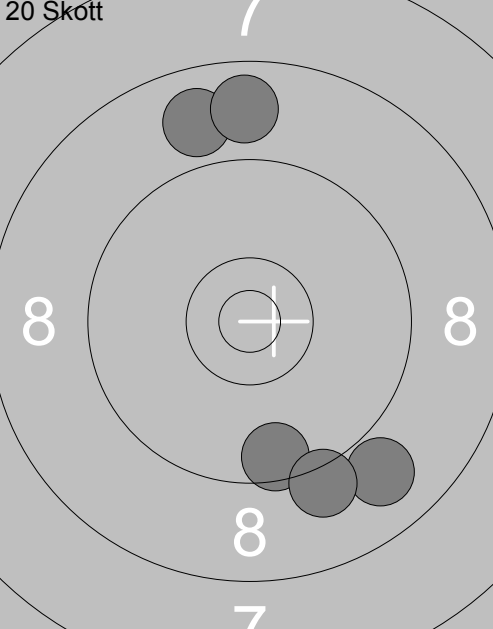
<p>20 Skott</p> 	<p>11: 8.4 ↖</p> <p>12: 9.9 ↗</p> <p>13: 9.2 ↓</p> <p>14: 9.3 ↖</p> <p>15: 8.4 ↓</p>	<p>20 Skott</p> 	<p>16: 8.9 ↑</p> <p>17: 8.8 ↑</p> <p>18: 9.5 ↓</p> <p>19: 8.9 ↓</p> <p>20: 9.1 ↓</p>
Serie 43.0		Serie 42.0	
Total 133.0		Total 175.0	

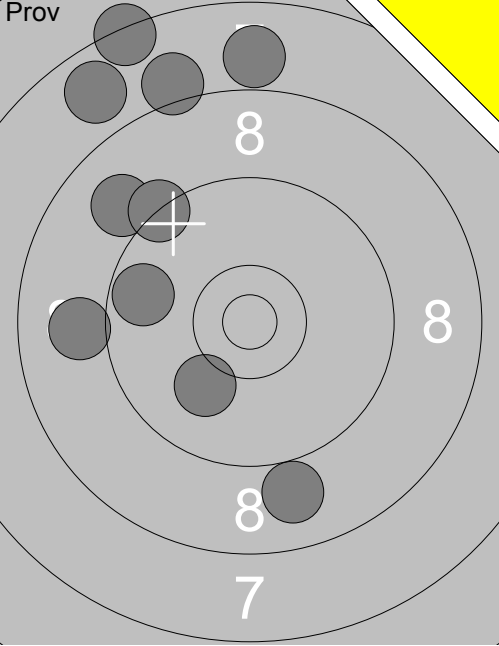
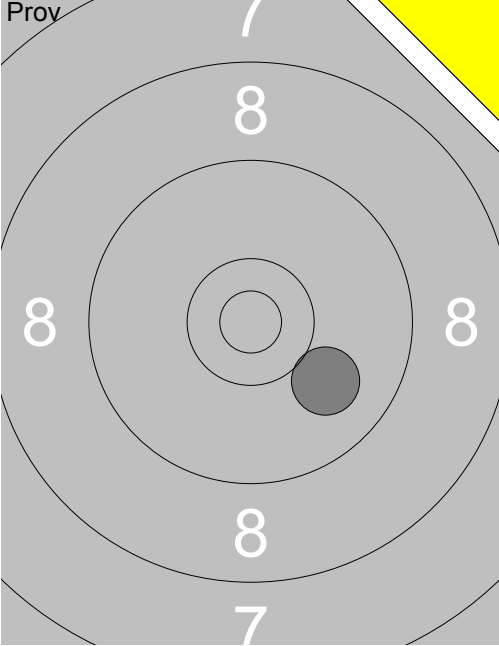
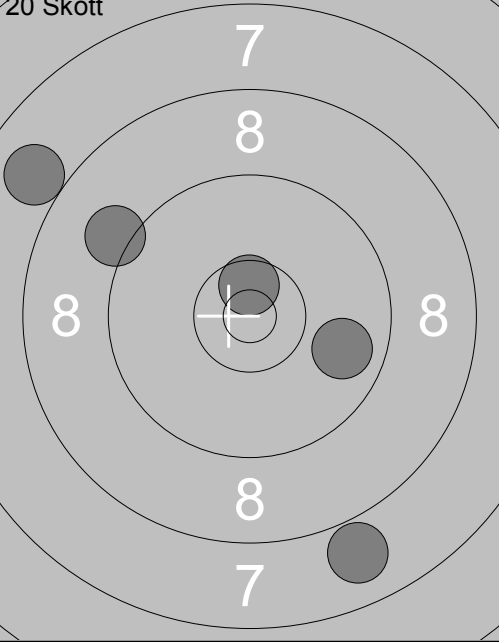
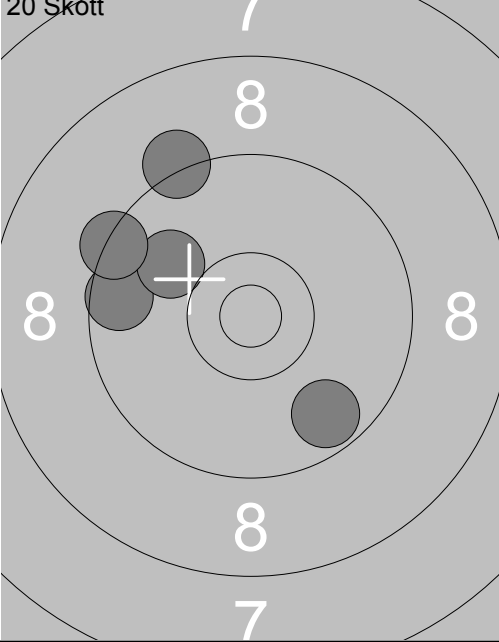
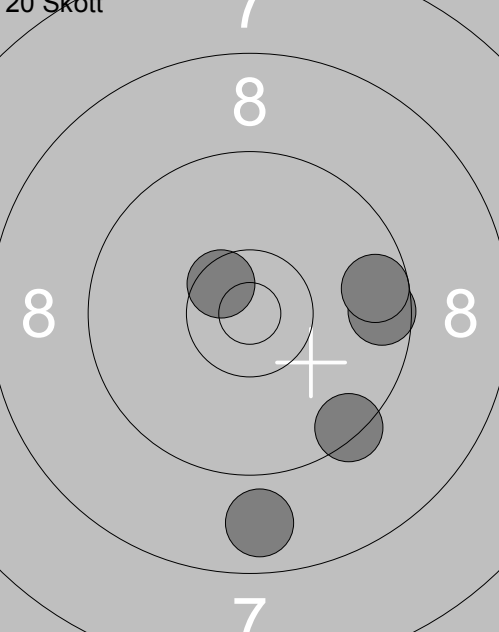
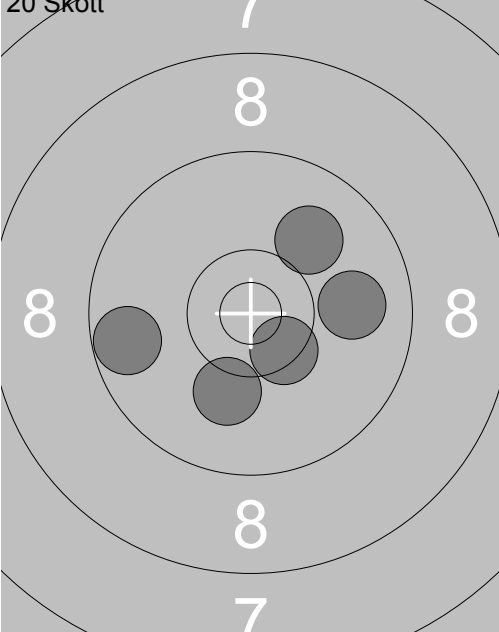
Skjutlag	Tavla	Mattias Eriksson			
5	4	Ramselefors		Sen-L	Vb
11.07.2017	Tavelträffen Korthåll 2017		Ramselefors SKF		
Prov		1: 10.1 ↘ 2: 9.0 ↖ 3: 7.4 ↗ 4: 9.0 ← 5: 7.8 ↗ 6: 9.7 ← 7: 7.9 ↑ 8: 9.3 ↗ 9: 8.9 ↓ 10: 8.1 ↑	Prov		11: 10.0 ↘
		Serie 83.0		Serie 10.0	
		Total 0.0		Total 0.0	
20 Skott		1: 9.1 ↖ 2: 10.6x↑ 3: 9.8 → 4: 7.9 ↓ 5: 7.9 ↖	20 Skott		6: 9.6 ← 7: 9.7 ↘ 8: 10.0 ↖ 9: 9.4 ↖ 10: 9.2 ↗
		Serie 42.0		Serie 46.0	
		Total 42.0		Total 88.0	
20 Skott		11: 9.6 → 12: 9.6 → 13: 8.8 ↓ 14: 10.5x↘ 15: 9.4 ↘	20 Skott		16: 10.1 ↓ 17: 10.4x↘ 18: 9.9 → 19: 10.0 ↗ 20: 9.7 ←
		Serie 45.0		Serie 48.0	
		Total 133.0		Total 181.0	

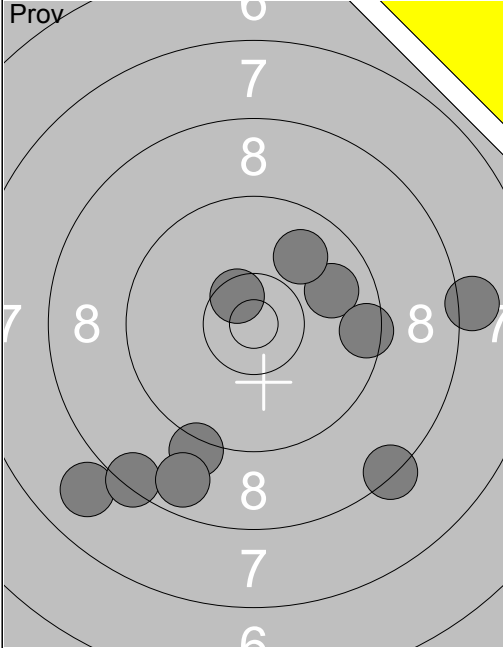
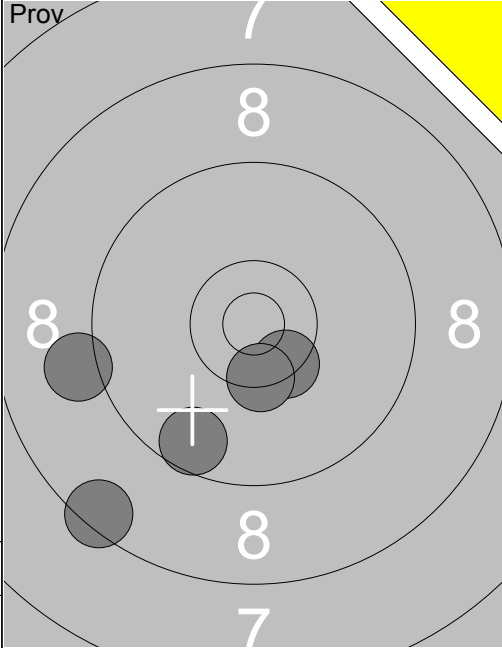
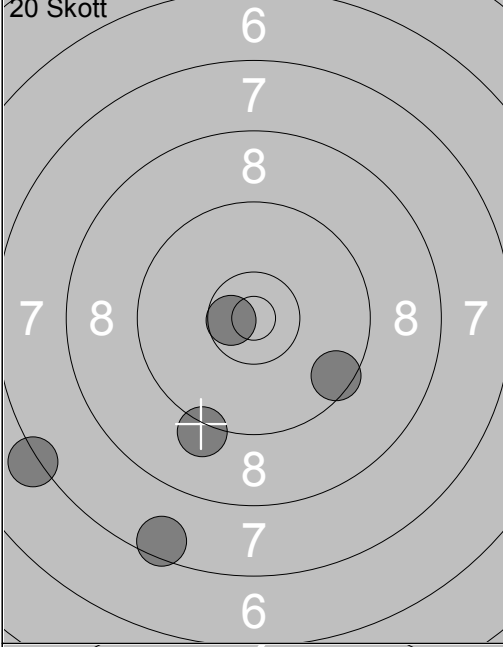
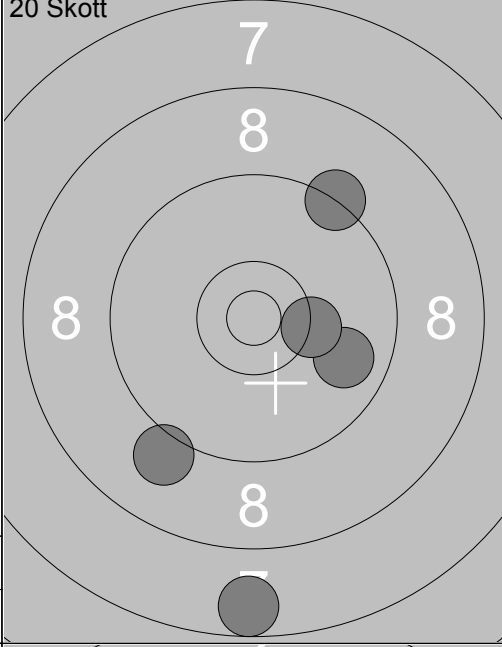
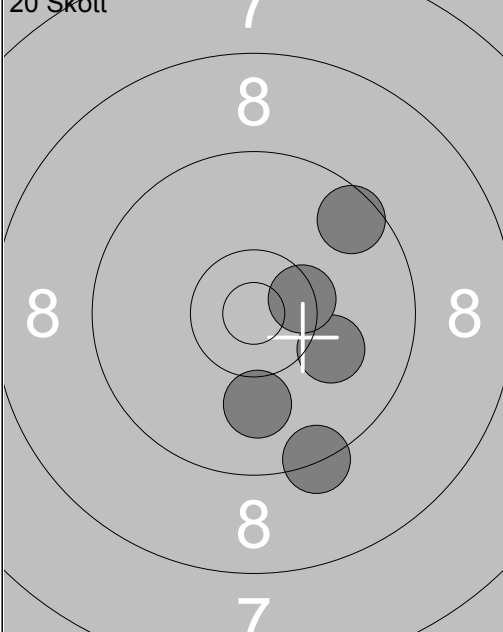
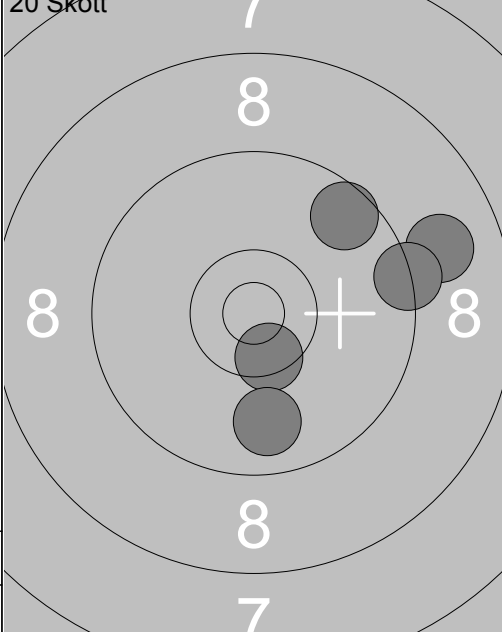
Skjutlag	Tavla	Mikael Gustafsson				
5	5	Vindeln		Ramselefors	Sen-L	Vb
11.07.2017		Tavelträffen Korthåll 2017		Ramselefors SKF		
	1: 9.9 →		11: 10.4x↘			
	2: 9.2 ↓		12: 8.5 ↓			
	3: 8.1 →		13: 10.4x↓			
	4: 8.4 ↘		14: 9.6 ↓			
	5: 9.5 →		15: 9.1 ←			
	6: 9.9 ↗					
	7: 7.9 ↓					
	8: 8.4 ↓					
	9: 10.5x↘					
	10: 8.8 ↓					
	Serie 85.0		Serie 46.0			
	Total 0.0		Total 0.0			
	1: 9.5 ↘		6: 9.3 ↗			
	2: 7.2 ↙		7: 9.1 ↓			
	3: 9.2 ↓		8: 7.6 ↓			
	4: 7.5 ↓		9: 9.8 →			
	5: 10.6x←		10: 10.3 →			
	Serie 42.0		Serie 44.0			
	Total 42.0		Total 86.0			
	11: 9.3 ↓		16: 9.6 ↗			
	12: 10.1 →		17: 10.5x↓			
	13: 10.0 ↓		18: 8.9 →			
	14: 9.6 ↗		19: 9.3 →			
	15: 10.4x→		20: 9.8 ↓			
	Serie 48.0		Serie 45.0			
	Total 134.0		Total 179.0			

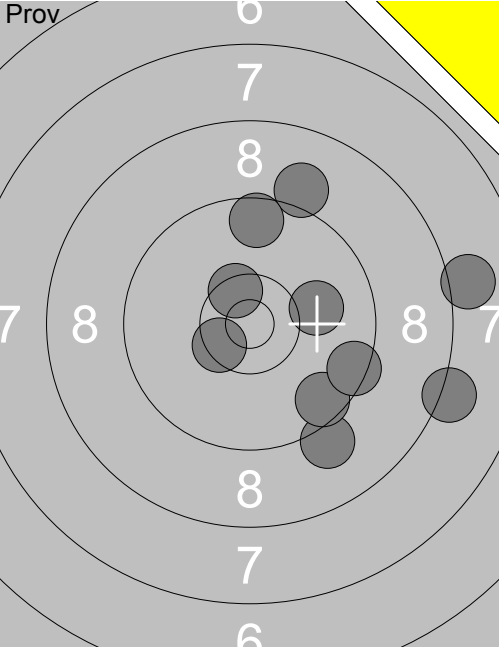
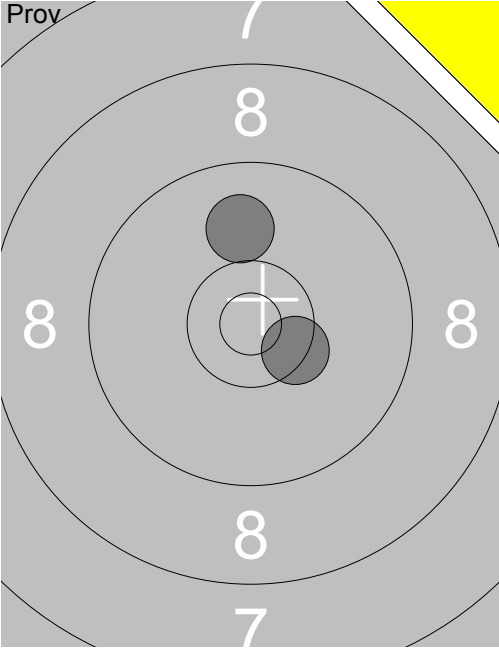
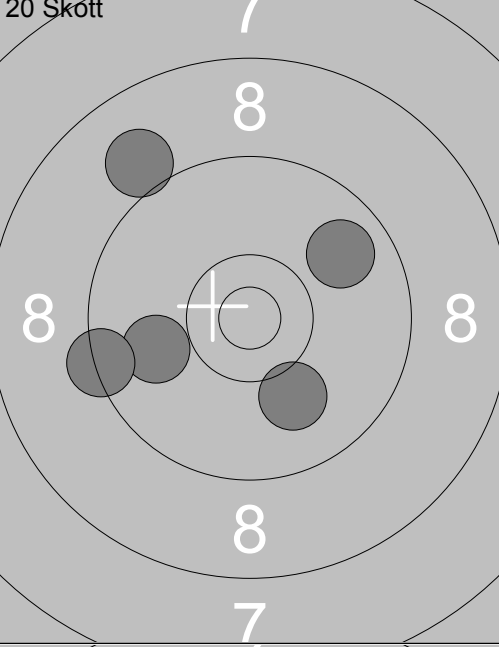
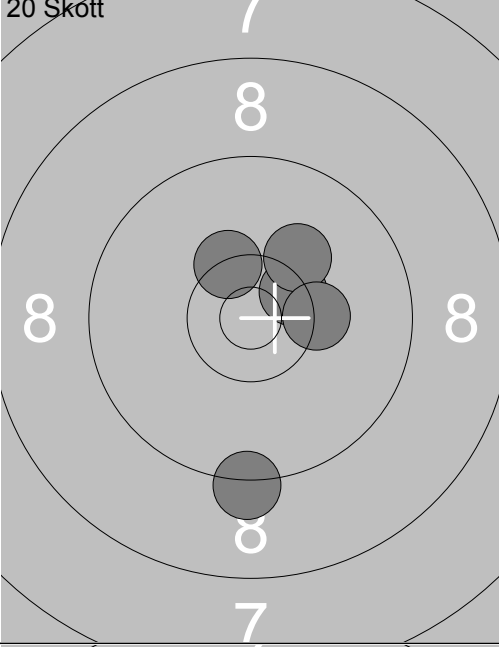
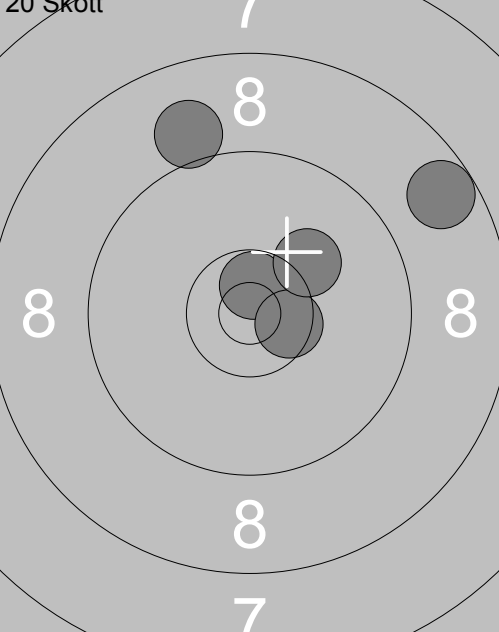
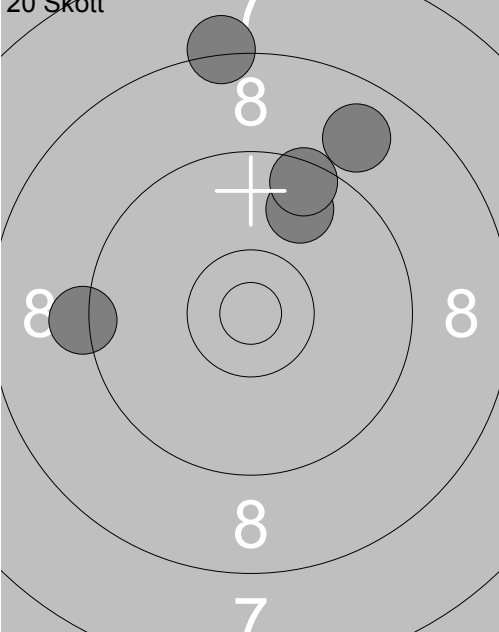
Skjuttag	Tavla	Bert-Ove Hägglund			
5	6	Ramselefors		Vet-L	Vb
11.07.2017	Tavelträffen Korthåll 2017		Ramselefors SKF		
Prov		1: 9.1 ↘		11: 10.4x↘	
		2: 8.2 ➔		12: 10.0 ↑	
		3: 9.6 ↘			
		4: 9.1 ↑			
		5: 10.5x↘			
		6: 8.0 ➔			
		7: 10.1 ➔			
		8: 9.6 ↑			
		9: 10.5x↘			
		10: 9.5 ➔			
		Serie 91.0		Serie 20.0	
		Total 0.0		Total 0.0	
20 Skott		1: 9.0 ↖		6: 10.4x↗	
		2: 10.0 ↘		7: 9.2 ↓	
		3: 9.9 ←		8: 10.4x↘	
		4: 9.4 ←		9: 10.2 ↗	
		5: 9.8 ↗		10: 10.3 ➔	
		Serie 46.0		Serie 49.0	
		Total 46.0		Total 95.0	
20 Skott		11: 9.0 ↑		16: 8.2 ↑	
		12: 10.7x↗		17: 9.2 ←	
		13: 8.7 ↗		18: 9.8 ↗	
		14: 10.5x➔		19: 8.9 ↗	
		15: 10.2 ↗		20: 9.5 ↑	
		Serie 47.0		Serie 43.0	
		Total 142.0		Total 185.0	

	<p>1: 9.8 → 2: 9.0 ↓ 3: 8.0 ↘ 4: 10.3 ↗ 5: 9.8 ↘ 6: 9.5 → 7: 10.8x→ 8: 10.7x→</p>		<p>1: 9.9 ← 2: 10.0 ↘ 3: 10.3x↘ 4: 9.9 ↘ 5: 9.2 ↗</p>
<p>Serie 74.0 Total 0.0</p>		<p>Serie 47.0 Total 47.0</p>	
	<p>6: 9.3 ↗ 7: 9.8 ↓ 8: 9.1 ↓ 9: 9.3 ↓ 10: 9.5 ↘</p>		<p>11: 9.7 ↗ 12: 10.2 ↓ 13: 10.1 ← 14: 9.5 ← 15: 8.9 ↘</p>
<p>Serie 45.0 Total 92.0</p>		<p>Serie 46.0 Total 138.0</p>	
	<p>16: 9.8 ↑ 17: 9.4 ↓ 18: 10.9x↗ 19: 9.7 ↓ 20: 10.1 ↓</p>		
<p>Serie 47.0 Total 185.0</p>			

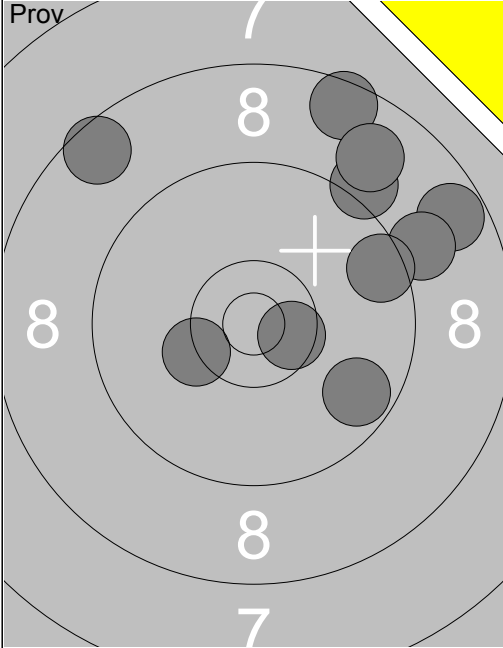
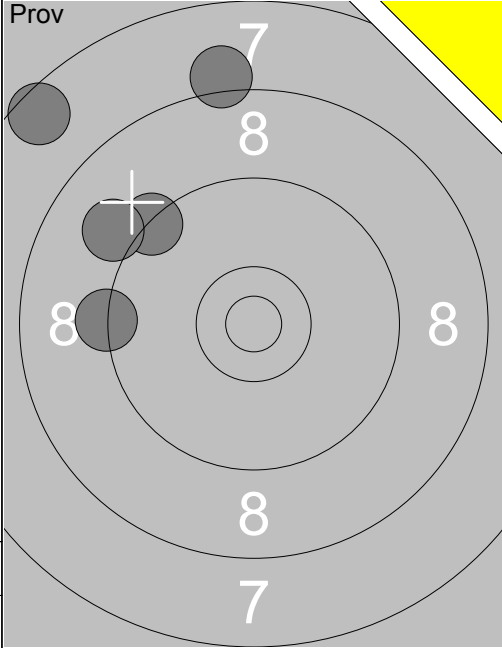
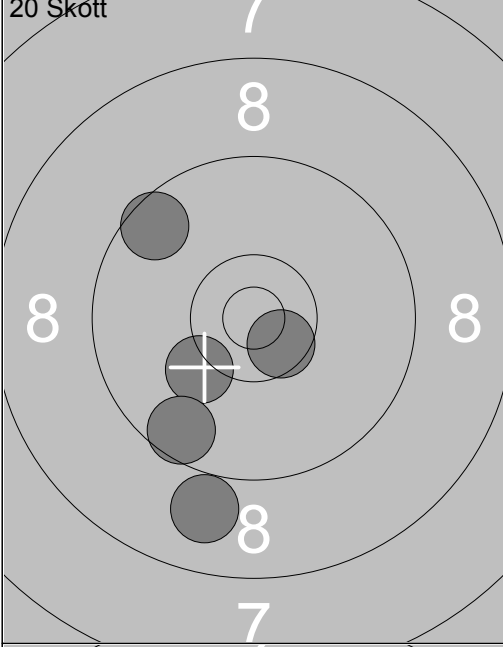
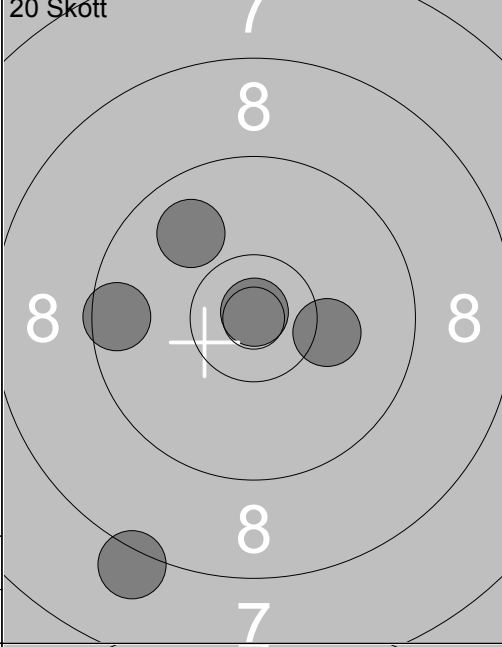
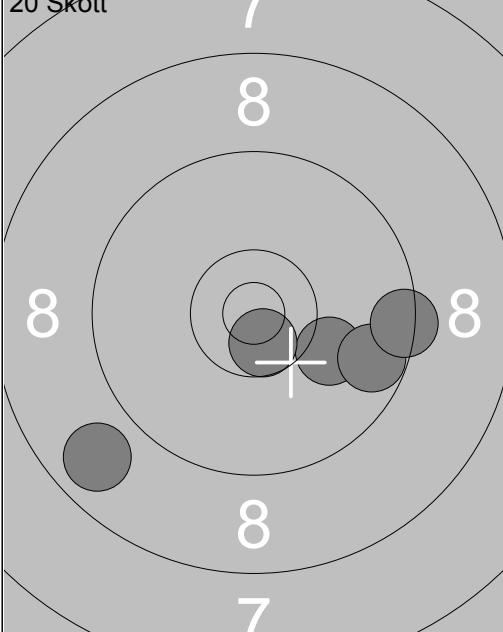
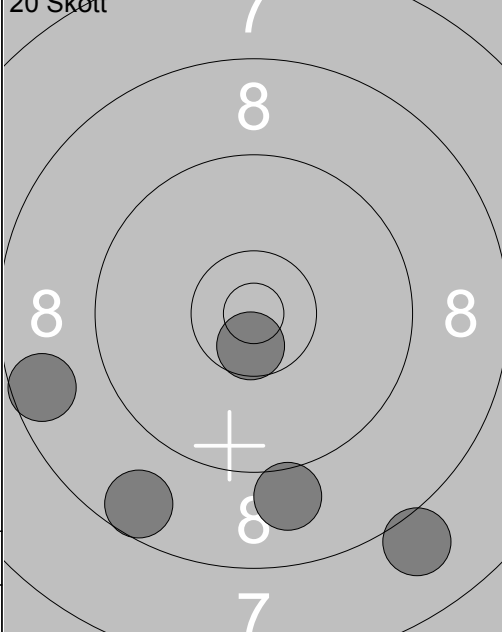
Skjuttag	Tavla	Andre Engström		Jun-L	No
5	8	Vindeln	Piteå		
11.07.2017		Tavelträffen Korthåll 2017	Ramselefors SKF		
Prov		1: 8.7 ↗ 2: 9.7 ↘ 3: 10.5x↘ 4: 9.1 ↗ 5: 9.5 ↗ 6: 9.1 ↗ 7: 8.5 ↗ 8: 8.9 ↗ 9: 8.6 ↖ 10: 10.3x↖	Prov	11: 9.3 ↖ 12: 9.3 ← 13: 8.1 ↑ 14: 7.6 ↖ 15: 9.0 ↖	
		Serie 88.0 Total 0.0		Serie 42.0 Total 0.0	
20 Skott		1: 9.6 ↖ 2: 10.2 ↘ 3: 9.6 ↘ 4: 8.9 ↘ 5: 10.6x↘	20 Skott	6: 8.2 ↘ 7: 10.9x↗ 8: 9.9 ↖ 9: 9.6 ← 10: 10.2 →	
		Serie 46.0 Total 46.0		Serie 46.0 Total 92.0	
20 Skott		11: 8.8 ↘ 12: 10.1 ↘ 13: 9.7 ↘ 14: 9.4 → 15: 10.6x↘	20 Skott	16: 8.6 ← 17: 8.6 ↘ 18: 8.0 ↘ 19: 10.6x↘ 20: 9.0 ↘	
		Serie 46.0 Total 138.0		Serie 43.0 Total 181.0	

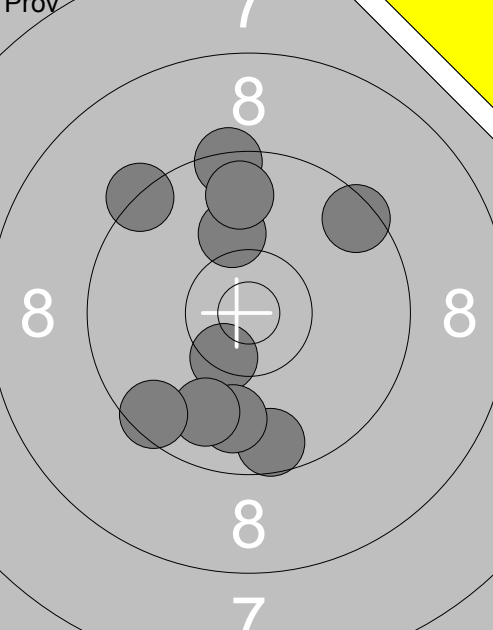
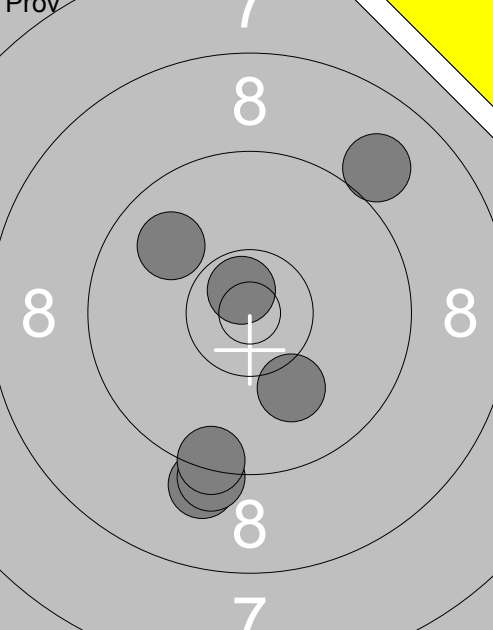
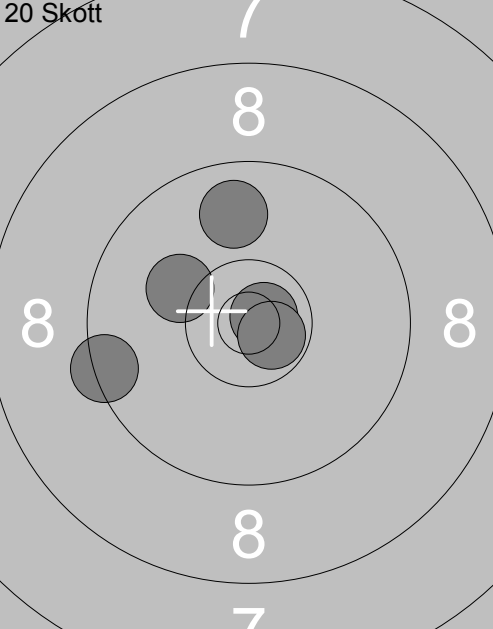
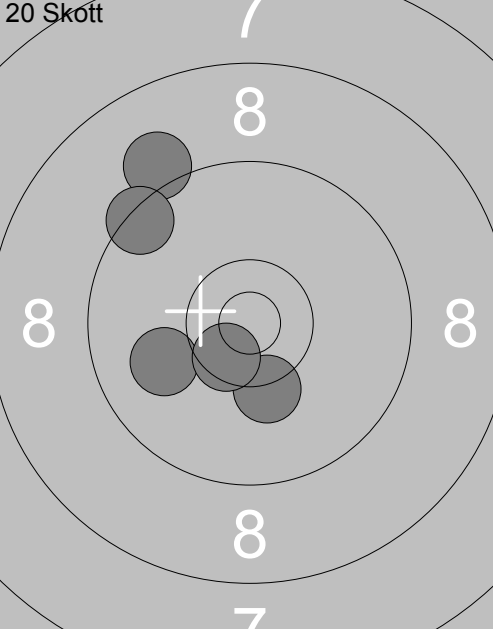
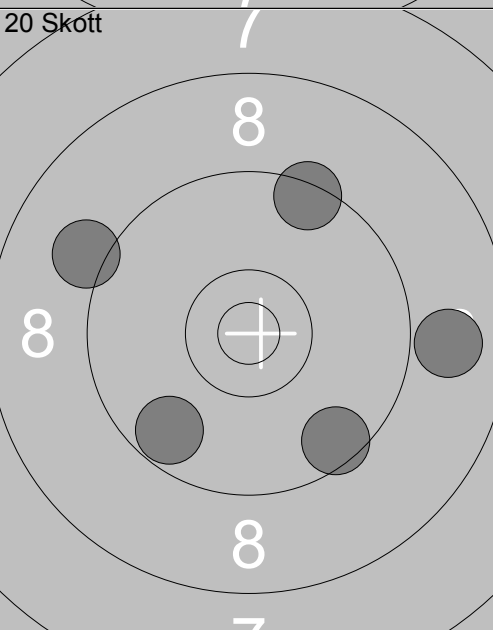
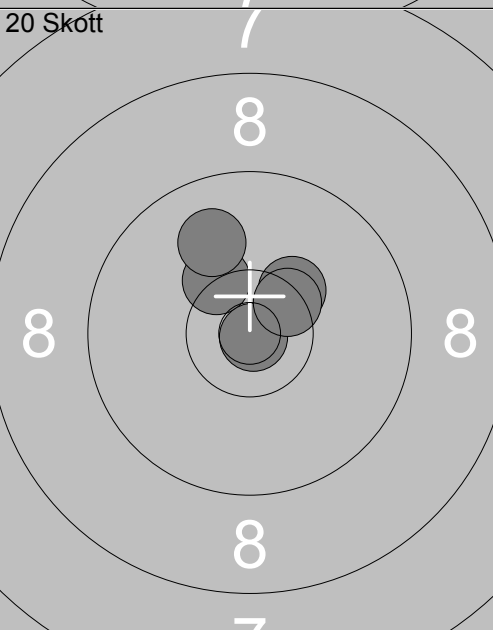
<div style="text-align: center;">Prov</div> 	<div style="text-align: center;">Prov</div> 	<table style="width:100%; border-collapse: collapse;"> <tr><td>1:</td><td>9.5 ↗</td><td>11:</td><td>9.0 ↗</td></tr> <tr><td>2:</td><td>9.6 ↓</td><td>12:</td><td>9.9 ↖</td></tr> <tr><td>3:</td><td>10.4x ↘</td><td>13:</td><td>9.1 ↓</td></tr> <tr><td>4:</td><td>9.4 ↑</td><td>14:</td><td>9.2 ↓</td></tr> <tr><td>5:</td><td>9.9 ↓</td><td>15:</td><td>10.1 ↘</td></tr> <tr><td>6:</td><td>10.1 ↑</td><td>16:</td><td>10.7x ↗</td></tr> <tr><td>7:</td><td>9.8 ↓</td><td>17:</td><td>9.4 ↓</td></tr> <tr><td>8:</td><td>9.3 ↖</td><td></td><td></td></tr> <tr><td>9:</td><td>9.5 ↘</td><td></td><td></td></tr> <tr><td>10:</td><td>9.7 ↑</td><td></td><td></td></tr> <tr><td colspan="2">Serie 92.0</td><td colspan="2">Serie 65.0</td></tr> <tr><td colspan="2">Total 0.0</td><td colspan="2">Total 0.0</td></tr> </table>	1:	9.5 ↗	11:	9.0 ↗	2:	9.6 ↓	12:	9.9 ↖	3:	10.4x ↘	13:	9.1 ↓	4:	9.4 ↑	14:	9.2 ↓	5:	9.9 ↓	15:	10.1 ↘	6:	10.1 ↑	16:	10.7x ↗	7:	9.8 ↓	17:	9.4 ↓	8:	9.3 ↖			9:	9.5 ↘			10:	9.7 ↑			Serie 92.0		Serie 65.0		Total 0.0		Total 0.0	
1:	9.5 ↗	11:	9.0 ↗																																															
2:	9.6 ↓	12:	9.9 ↖																																															
3:	10.4x ↘	13:	9.1 ↓																																															
4:	9.4 ↑	14:	9.2 ↓																																															
5:	9.9 ↓	15:	10.1 ↘																																															
6:	10.1 ↑	16:	10.7x ↗																																															
7:	9.8 ↓	17:	9.4 ↓																																															
8:	9.3 ↖																																																	
9:	9.5 ↘																																																	
10:	9.7 ↑																																																	
Serie 92.0		Serie 65.0																																																
Total 0.0		Total 0.0																																																
<div style="text-align: center;">20 Skott</div> 	<div style="text-align: center;">20 Skott</div> 	<table style="width:100%; border-collapse: collapse;"> <tr><td>1:</td><td>9.4 ←</td><td>6:</td><td>9.1 ↖</td></tr> <tr><td>2:</td><td>10.8x ↗</td><td>7:</td><td>10.0 ←</td></tr> <tr><td>3:</td><td>10.7x ↘</td><td>8:</td><td>10.3 ↓</td></tr> <tr><td>4:</td><td>9.8 ↑</td><td>9:</td><td>10.5x ↘</td></tr> <tr><td>5:</td><td>10.2 ↖</td><td>10:</td><td>9.4 ↖</td></tr> <tr><td colspan="2">Serie 48.0</td><td colspan="2">Serie 48.0</td></tr> <tr><td colspan="2">Total 48.0</td><td colspan="2">Total 96.0</td></tr> </table>	1:	9.4 ←	6:	9.1 ↖	2:	10.8x ↗	7:	10.0 ←	3:	10.7x ↘	8:	10.3 ↓	4:	9.8 ↑	9:	10.5x ↘	5:	10.2 ↖	10:	9.4 ↖	Serie 48.0		Serie 48.0		Total 48.0		Total 96.0																					
1:	9.4 ←	6:	9.1 ↖																																															
2:	10.8x ↗	7:	10.0 ←																																															
3:	10.7x ↘	8:	10.3 ↓																																															
4:	9.8 ↑	9:	10.5x ↘																																															
5:	10.2 ↖	10:	9.4 ↖																																															
Serie 48.0		Serie 48.0																																																
Total 48.0		Total 96.0																																																
<div style="text-align: center;">20 Skott</div> 	<div style="text-align: center;">20 Skott</div> 	<table style="width:100%; border-collapse: collapse;"> <tr><td>11:</td><td>8.9 →</td><td>16:</td><td>10.3x ↗</td></tr> <tr><td>12:</td><td>9.1 ↖</td><td>17:</td><td>10.3x ↖</td></tr> <tr><td>13:</td><td>9.5 ↓</td><td>18:</td><td>10.9x ↘</td></tr> <tr><td>14:</td><td>9.4 ↑</td><td>19:</td><td>9.9 ↑</td></tr> <tr><td>15:</td><td>9.7 ↓</td><td>20:</td><td>10.5x ↗</td></tr> <tr><td colspan="2">Serie 44.0</td><td colspan="2">Serie 49.0</td></tr> <tr><td colspan="2">Total 140.0</td><td colspan="2">Total 189.0</td></tr> </table>	11:	8.9 →	16:	10.3x ↗	12:	9.1 ↖	17:	10.3x ↖	13:	9.5 ↓	18:	10.9x ↘	14:	9.4 ↑	19:	9.9 ↑	15:	9.7 ↓	20:	10.5x ↗	Serie 44.0		Serie 49.0		Total 140.0		Total 189.0																					
11:	8.9 →	16:	10.3x ↗																																															
12:	9.1 ↖	17:	10.3x ↖																																															
13:	9.5 ↓	18:	10.9x ↘																																															
14:	9.4 ↑	19:	9.9 ↑																																															
15:	9.7 ↓	20:	10.5x ↗																																															
Serie 44.0		Serie 49.0																																																
Total 140.0		Total 189.0																																																

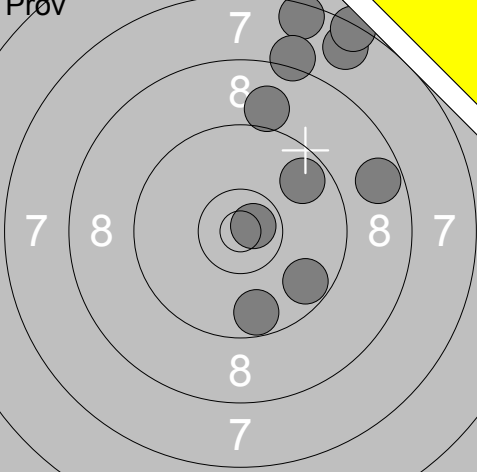
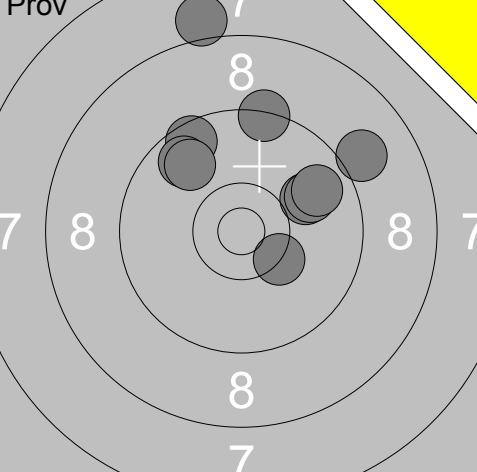
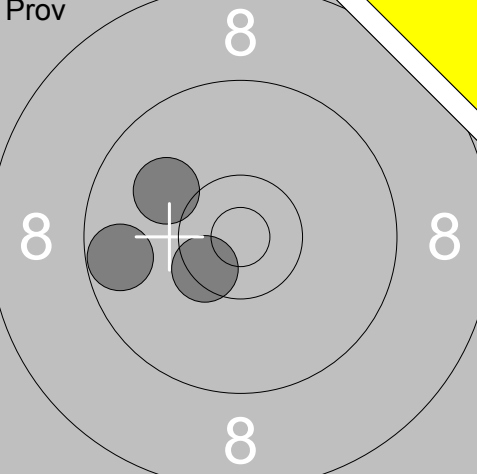
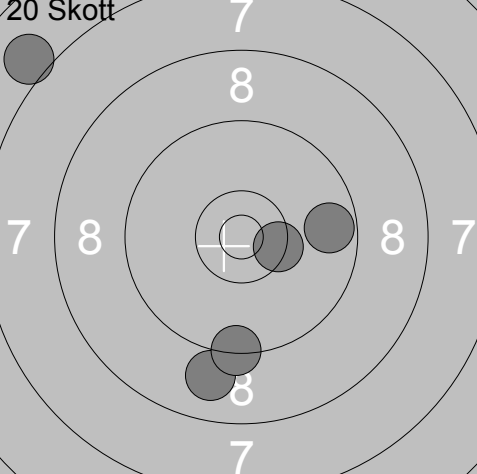
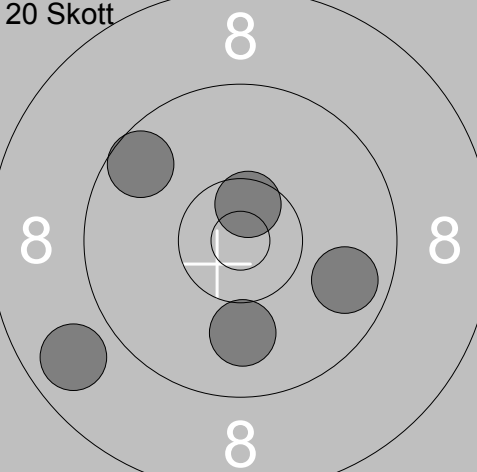
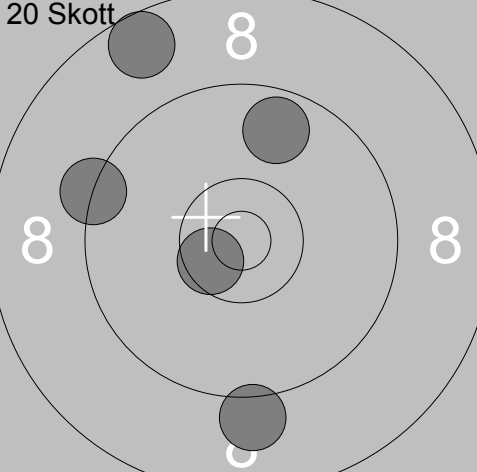
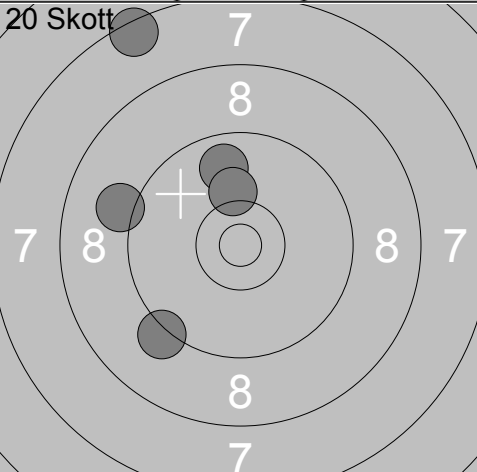
<p>Prov</p> 	<table border="1" style="width:100%; border-collapse: collapse;"> <tr><td>1:</td><td>7.7</td><td>↗</td></tr> <tr><td>2:</td><td>8.7</td><td>→</td></tr> <tr><td>3:</td><td>7.5</td><td>↗</td></tr> <tr><td>4:</td><td>7.4</td><td>↗</td></tr> <tr><td>5:</td><td>8.2</td><td>↗</td></tr> <tr><td>6:</td><td>9.7</td><td>↗</td></tr> <tr><td>7:</td><td>10.7x</td><td>→</td></tr> <tr><td>8:</td><td>9.0</td><td>↗</td></tr> <tr><td>9:</td><td>9.7</td><td>↓</td></tr> <tr><td>10:</td><td>9.7</td><td>↘</td></tr> <tr><td colspan="2">Serie</td><td>83.0</td></tr> <tr><td colspan="2">Total</td><td>0.0</td></tr> </table>	1:	7.7	↗	2:	8.7	→	3:	7.5	↗	4:	7.4	↗	5:	8.2	↗	6:	9.7	↗	7:	10.7x	→	8:	9.0	↗	9:	9.7	↓	10:	9.7	↘	Serie		83.0	Total		0.0	<p>Prov</p> 	<table border="1" style="width:100%; border-collapse: collapse;"> <tr><td>11:</td><td>10.0</td><td>→</td></tr> <tr><td>12:</td><td>8.0</td><td>↗</td></tr> <tr><td>13:</td><td>9.0</td><td>→</td></tr> <tr><td>14:</td><td>9.9</td><td>→</td></tr> <tr><td>15:</td><td>9.8</td><td>→</td></tr> <tr><td>16:</td><td>9.4</td><td>↗</td></tr> <tr><td>17:</td><td>10.3x</td><td>↘</td></tr> <tr><td>18:</td><td>9.6</td><td>↗</td></tr> <tr><td>19:</td><td>9.7</td><td>↗</td></tr> <tr><td>20:</td><td>9.8</td><td>↗</td></tr> <tr><td colspan="2">Serie</td><td>91.0</td></tr> <tr><td colspan="2">Total</td><td>0.0</td></tr> </table>	11:	10.0	→	12:	8.0	↗	13:	9.0	→	14:	9.9	→	15:	9.8	→	16:	9.4	↗	17:	10.3x	↘	18:	9.6	↗	19:	9.7	↗	20:	9.8	↗	Serie		91.0	Total		0.0
1:	7.7	↗																																																																									
2:	8.7	→																																																																									
3:	7.5	↗																																																																									
4:	7.4	↗																																																																									
5:	8.2	↗																																																																									
6:	9.7	↗																																																																									
7:	10.7x	→																																																																									
8:	9.0	↗																																																																									
9:	9.7	↓																																																																									
10:	9.7	↘																																																																									
Serie		83.0																																																																									
Total		0.0																																																																									
11:	10.0	→																																																																									
12:	8.0	↗																																																																									
13:	9.0	→																																																																									
14:	9.9	→																																																																									
15:	9.8	→																																																																									
16:	9.4	↗																																																																									
17:	10.3x	↘																																																																									
18:	9.6	↗																																																																									
19:	9.7	↗																																																																									
20:	9.8	↗																																																																									
Serie		91.0																																																																									
Total		0.0																																																																									
<p>Prov</p> 	<table border="1" style="width:100%; border-collapse: collapse;"> <tr><td>21:</td><td>10.4x</td><td>↙</td></tr> <tr><td>22:</td><td>9.7</td><td>←</td></tr> <tr><td>23:</td><td>10.0</td><td>↖</td></tr> <tr><td colspan="2">Serie</td><td>29.0</td></tr> <tr><td colspan="2">Total</td><td>0.0</td></tr> </table>	21:	10.4x	↙	22:	9.7	←	23:	10.0	↖	Serie		29.0	Total		0.0	<p>20 Skott</p> 	<table border="1" style="width:100%; border-collapse: collapse;"> <tr><td>1:</td><td>7.0</td><td>↖</td></tr> <tr><td>2:</td><td>8.9</td><td>↓</td></tr> <tr><td>3:</td><td>10.4x</td><td>→</td></tr> <tr><td>4:</td><td>9.7</td><td>→</td></tr> <tr><td>5:</td><td>9.3</td><td>↓</td></tr> <tr><td colspan="2">Serie</td><td>43.0</td></tr> <tr><td colspan="2">Total</td><td>43.0</td></tr> </table>	1:	7.0	↖	2:	8.9	↓	3:	10.4x	→	4:	9.7	→	5:	9.3	↓	Serie		43.0	Total		43.0																																				
21:	10.4x	↙																																																																									
22:	9.7	←																																																																									
23:	10.0	↖																																																																									
Serie		29.0																																																																									
Total		0.0																																																																									
1:	7.0	↖																																																																									
2:	8.9	↓																																																																									
3:	10.4x	→																																																																									
4:	9.7	→																																																																									
5:	9.3	↓																																																																									
Serie		43.0																																																																									
Total		43.0																																																																									
<p>20 Skott</p> 	<table border="1" style="width:100%; border-collapse: collapse;"> <tr><td>6:</td><td>10.6x</td><td>↗</td></tr> <tr><td>7:</td><td>9.6</td><td>↗</td></tr> <tr><td>8:</td><td>8.8</td><td>↙</td></tr> <tr><td>9:</td><td>10.0</td><td>↓</td></tr> <tr><td>10:</td><td>9.8</td><td>↘</td></tr> <tr><td colspan="2">Serie</td><td>46.0</td></tr> <tr><td colspan="2">Total</td><td>89.0</td></tr> </table>	6:	10.6x	↗	7:	9.6	↗	8:	8.8	↙	9:	10.0	↓	10:	9.8	↘	Serie		46.0	Total		89.0	<p>20 Skott</p> 	<table border="1" style="width:100%; border-collapse: collapse;"> <tr><td>11:</td><td>9.7</td><td>↗</td></tr> <tr><td>12:</td><td>9.3</td><td>←</td></tr> <tr><td>13:</td><td>10.6x</td><td>↙</td></tr> <tr><td>14:</td><td>8.6</td><td>↗</td></tr> <tr><td>15:</td><td>9.1</td><td>↓</td></tr> <tr><td colspan="2">Serie</td><td>45.0</td></tr> <tr><td colspan="2">Total</td><td>134.0</td></tr> </table>	11:	9.7	↗	12:	9.3	←	13:	10.6x	↙	14:	8.6	↗	15:	9.1	↓	Serie		45.0	Total		134.0																														
6:	10.6x	↗																																																																									
7:	9.6	↗																																																																									
8:	8.8	↙																																																																									
9:	10.0	↓																																																																									
10:	9.8	↘																																																																									
Serie		46.0																																																																									
Total		89.0																																																																									
11:	9.7	↗																																																																									
12:	9.3	←																																																																									
13:	10.6x	↙																																																																									
14:	8.6	↗																																																																									
15:	9.1	↓																																																																									
Serie		45.0																																																																									
Total		134.0																																																																									
<p>20 Skott</p> 	<table border="1" style="width:100%; border-collapse: collapse;"> <tr><td>16:</td><td>9.2</td><td>↙</td></tr> <tr><td>17:</td><td>9.8</td><td>↗</td></tr> <tr><td>18:</td><td>9.1</td><td>←</td></tr> <tr><td>19:</td><td>7.5</td><td>↗</td></tr> <tr><td>20:</td><td>10.2</td><td>↗</td></tr> <tr><td colspan="2">Serie</td><td>44.0</td></tr> <tr><td colspan="2">Total</td><td>178.0</td></tr> </table>	16:	9.2	↙	17:	9.8	↗	18:	9.1	←	19:	7.5	↗	20:	10.2	↗	Serie		44.0	Total		178.0																																																					
16:	9.2	↙																																																																									
17:	9.8	↗																																																																									
18:	9.1	←																																																																									
19:	7.5	↗																																																																									
20:	10.2	↗																																																																									
Serie		44.0																																																																									
Total		178.0																																																																									

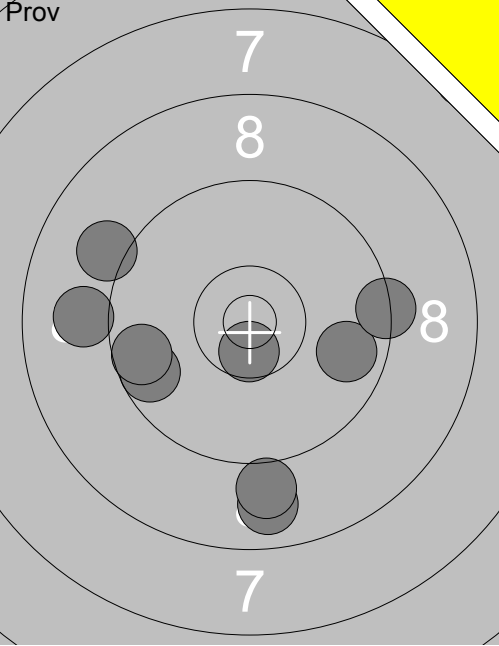
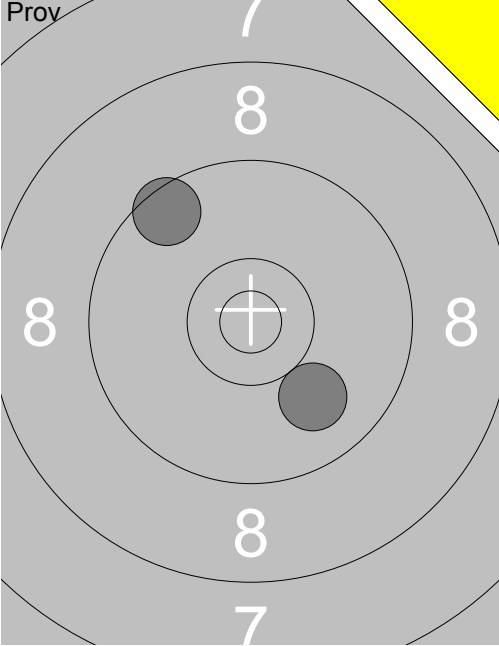
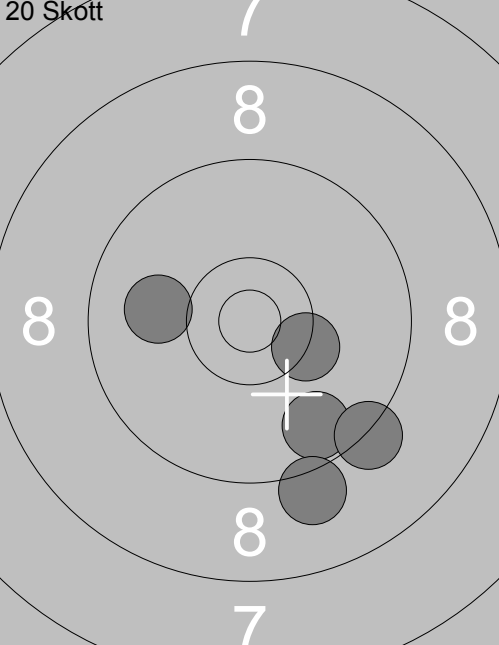
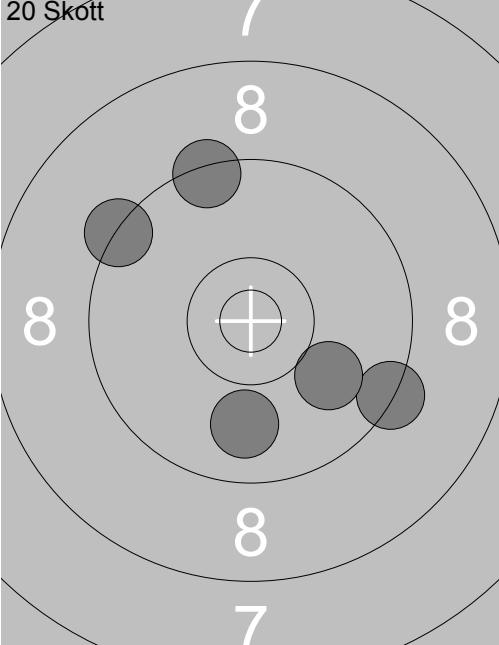
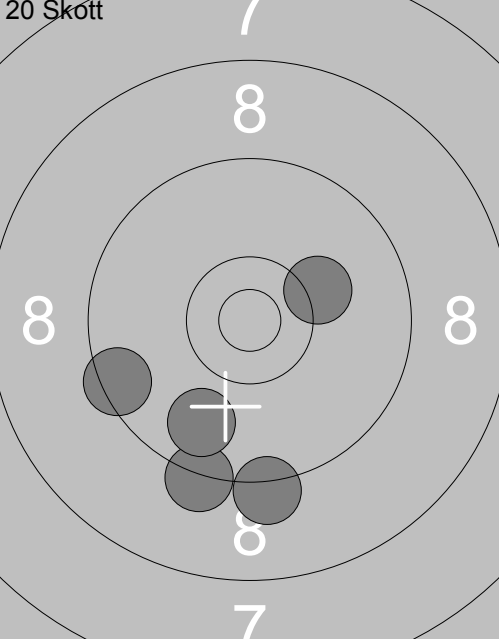
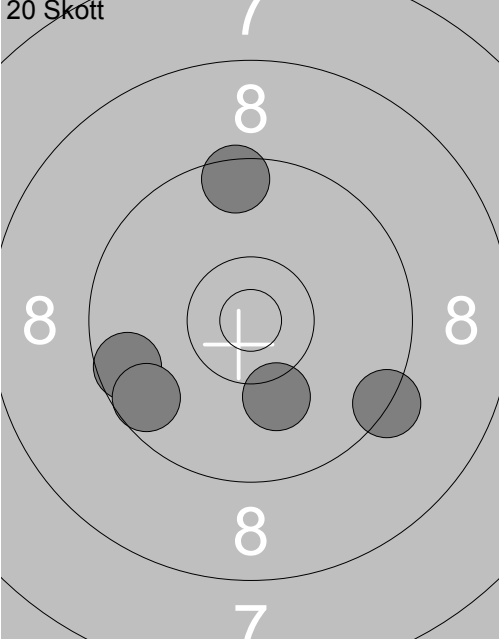
Skjuttag	Tavla	Hanna Johansson			
5	11	Vindeln	Vännäs	Jun-L	Vb
11.07.2017	Tavelträffen Korthåll 2017	Ramselefors SKF			
Prov		1: 7.1 ↗ 2: 9.8 ➔ 3: 9.4 ➔ 4: 9.1 ↙ 5: 8.8 ↓ 6: 9.6 ↙ 7: 9.0 ← 8: 10.6x↓ 9: 9.6 ↙ 10: 9.0 ↓	Prov		11: 10.0 ↘ 12: 9.5 ↗
	Serie 88.0			Serie 19.0	
	Total 0.0			Total 0.0	
20 Skott		1: 10.0← 2: 10.3x➔ 3: 9.7 ↓ 4: 9.1 ↓ 5: 9.3 ↓	20 Skott		6: 9.3 ➔ 7: 9.4 ↑ 8: 10.0↘ 9: 9.9 ↓ 10: 9.3 ↗
	Serie 47.0			Serie 46.0	
	Total 47.0			Total 93.0	
20 Skott		11: 9.2 ↓ 12: 9.3 ↓ 13: 9.5 ↙ 14: 10.2➔ 15: 9.8 ↓	20 Skott		16: 9.5 ↑ 17: 9.3 ➔ 18: 9.6 ↙ 19: 10.1 ↓ 20: 9.6 ↙
	Serie 46.0			Serie 46.0	
	Total 139.0			Total 185.0	

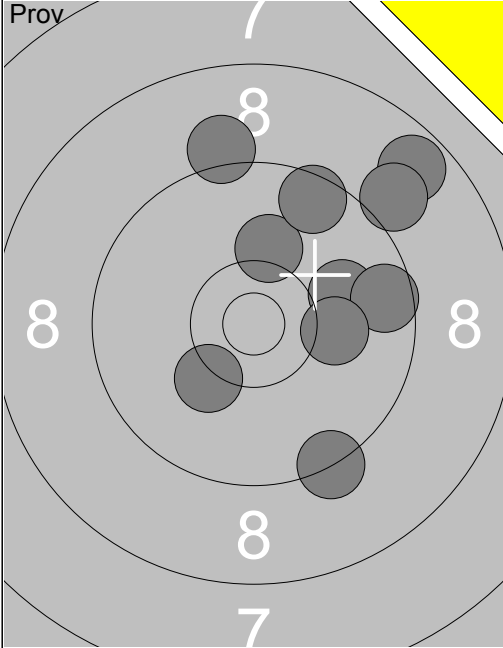
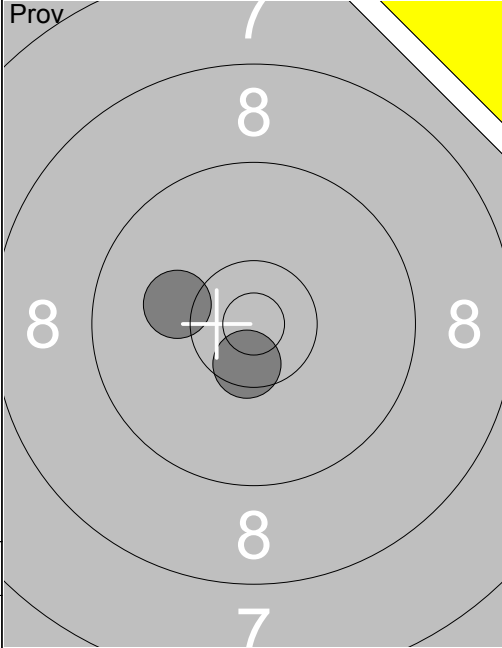
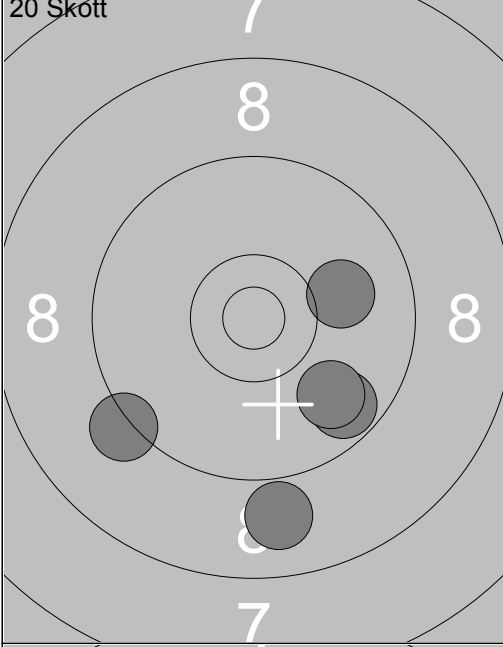
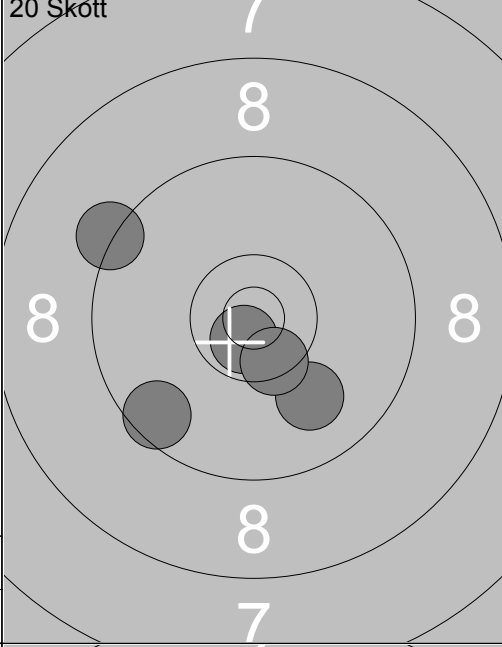
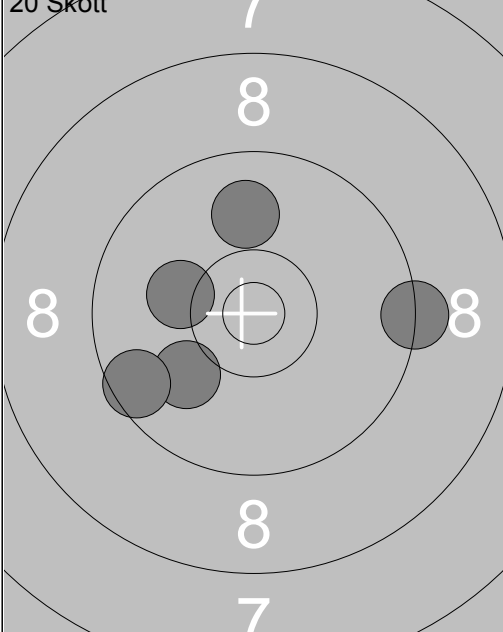
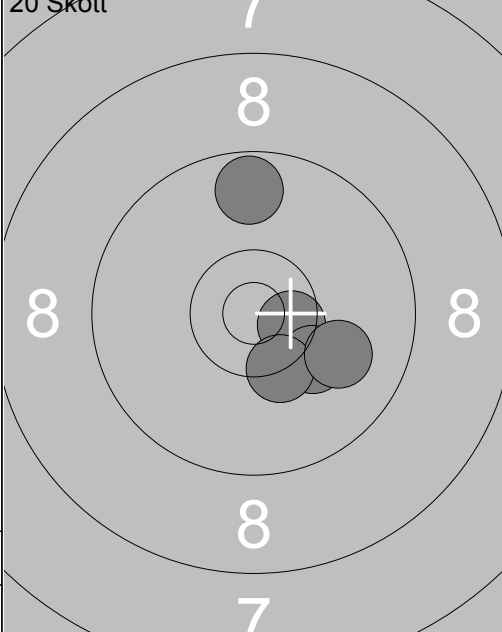
Skjutlag	Tavla	Sören Fredriksson			
5	12	Örsundsbro		Vet-L	Up
11.07.2017		Tavelträffen Korthåll 2017		Ramselefors SKF	
Prov		1: 8.7 ↗		11: 10.1 ↖	
		2: 10.0 →		12: 10.5x ↓	
		3: 9.6 →			
		4: 9.0 ↗			
		5: 10.2 ↑			
		6: 9.1 ↑			
		7: 10.1 →			
		8: 9.3 ↓			
		9: 9.5 ↗			
		10: 10.2x ↓			
		Serie 93.0		Serie 20.0	
		Total 0.0		Total 0.0	
20 Skott		1: 9.7 ↓		6: 10.0 ↓	
		2: 8.9 ↓		7: 9.3 ↖	
		3: 9.2 ↙		8: 9.6 ↓	
		4: 10.0 →		9: 10.7x ↓	
		5: 9.8 ↓		10: 10.5x ↓	
		Serie 45.0		Serie 48.0	
		Total 45.0		Total 93.0	
20 Skott		11: 10.0 ↙		16: 10.5x →	
		12: 9.3 →		17: 9.7 ↑	
		13: 10.2 ↖		18: 10.2 ↓	
		14: 9.9 ↑		19: 10.3x ↓	
		15: 9.6 ↙		20: 10.0 →	
		Serie 47.0		Serie 49.0	
		Total 140.0		Total 189.0	

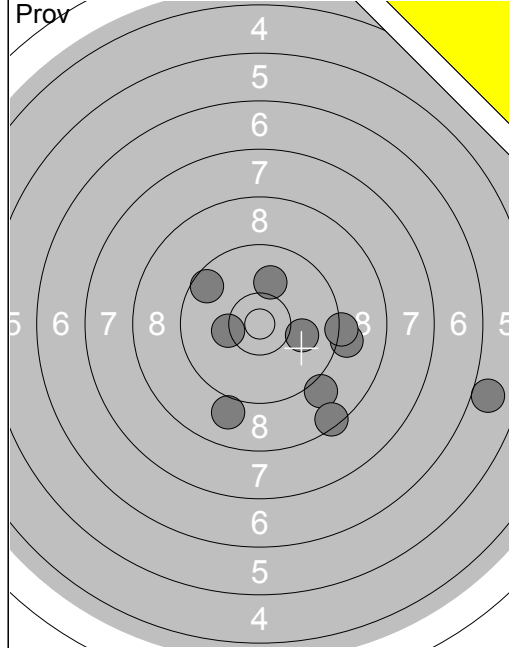

1:	6.0	➔
2:	10.3	←
3:	9.1	➔
4:	9.2	➔
5:	9.0	↘
6:	8.5	↘
7:	9.0	↘
8:	10.0	➔
9:	9.6	↖
10:	10.1	↗
Serie	89.0	
Total	0.0	

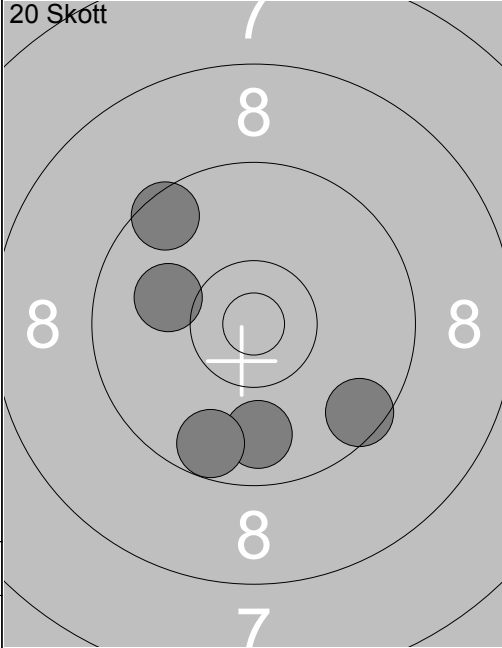

1:	9.5	↘
2:	9.8	↓
3:	9.5	↗
4:	10.0	←
5:	9.7	↘
Serie	46.0	
Total	46.0	

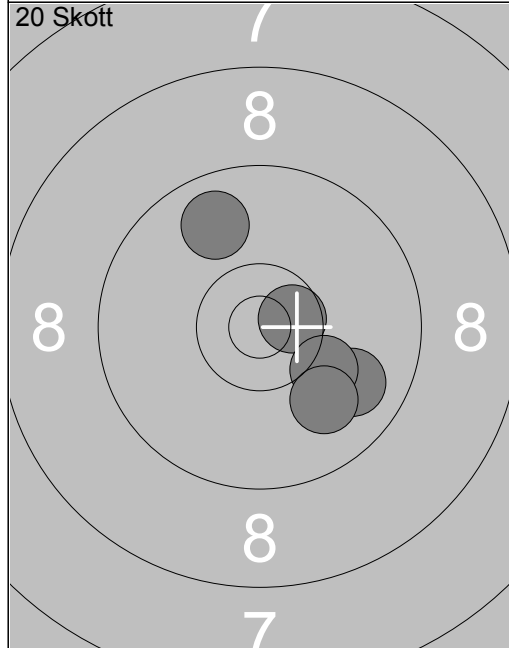

6:	9.8	↗
7:	9.9	↘
8:	10.6x	➔
9:	10.2	↘
10:	10.0	↘
Serie	48.0	
Total	94.0	

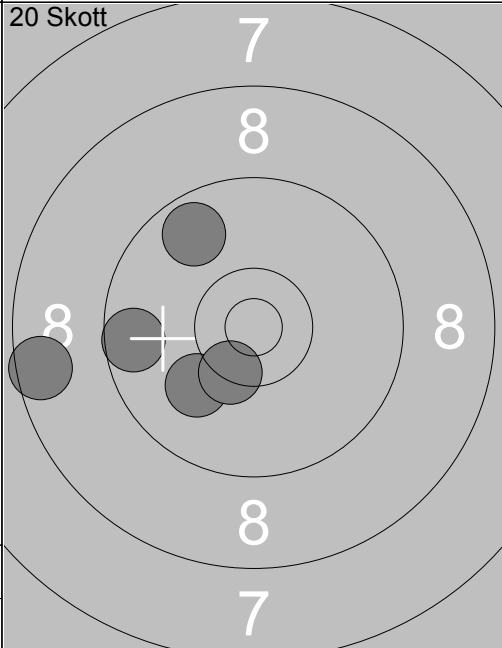

11:	9.7	↖
12:	8.6	←
13:	10.1	↘
14:	9.6	←
15:	10.4x	↘
Serie	46.0	
Total	140.0	

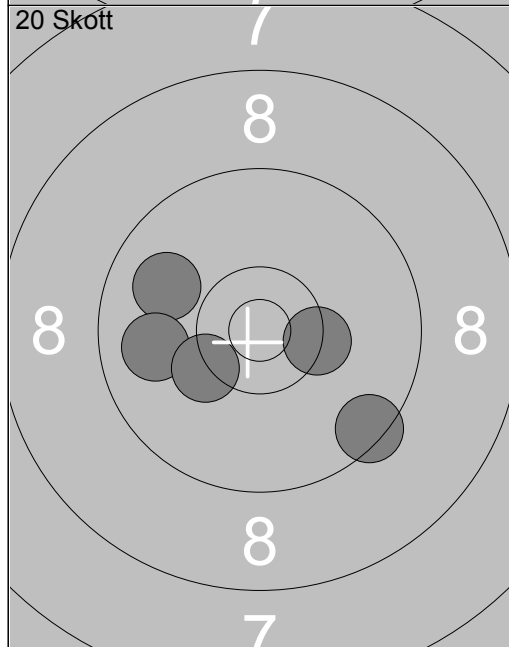

16:	10.4x	➔
17:	9.9	↖
18:	9.5	↘
19:	9.9	←
20:	10.3	↘
Serie	47.0	
Total	187.0	

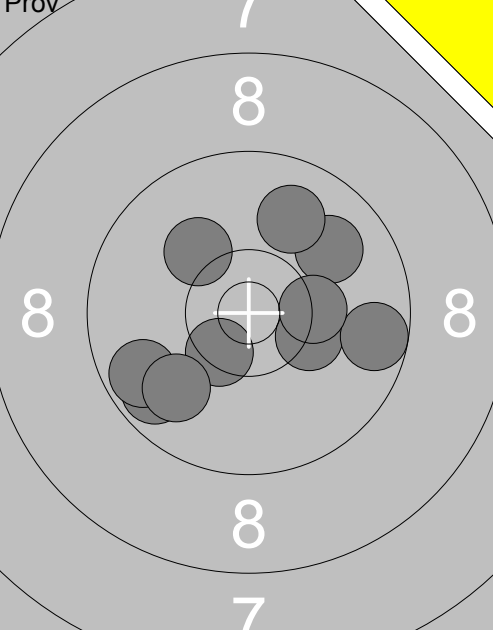
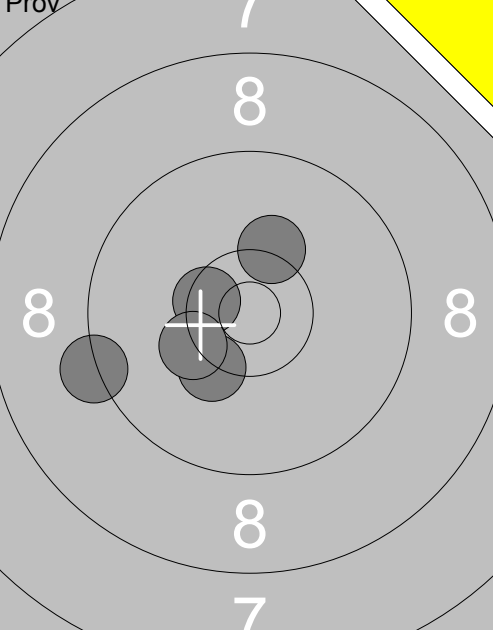
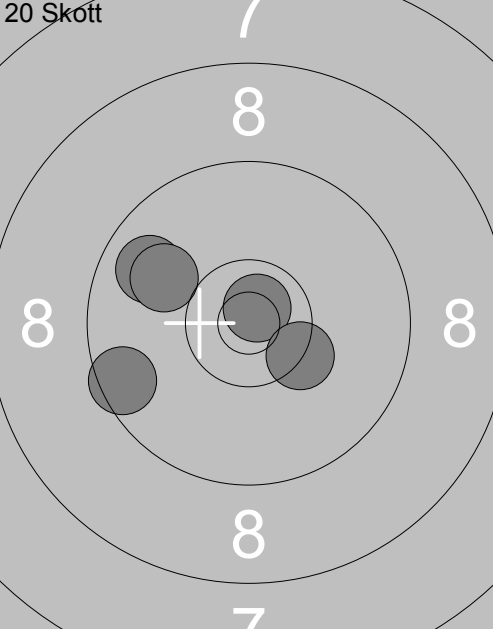
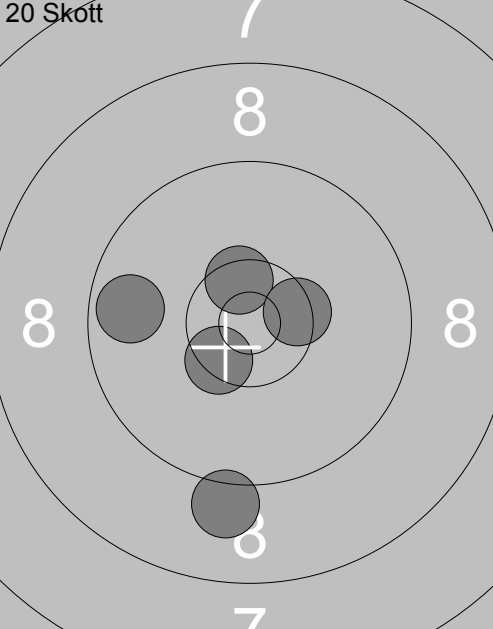
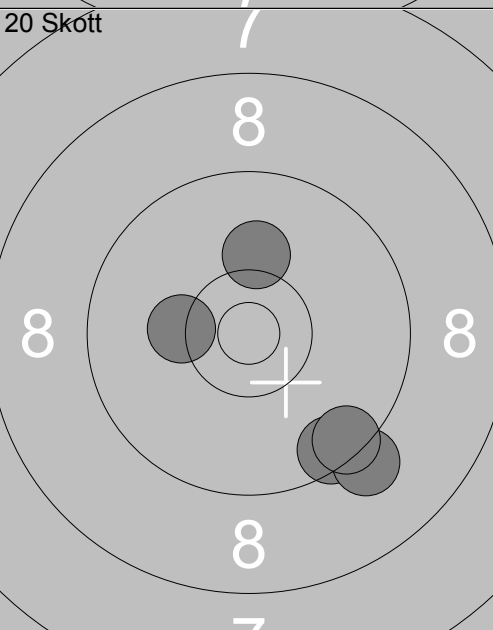
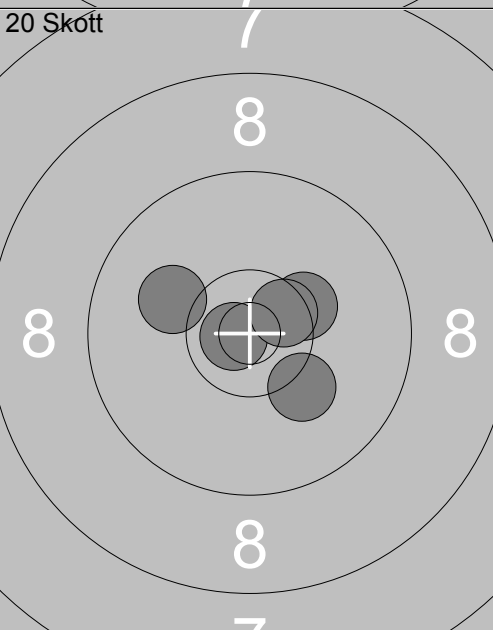
<div style="text-align: center;">Prov</div> 	<div style="text-align: center;">Prov</div> 	<table style="width:100%; border-collapse: collapse;"> <tr><td>1:</td><td>9.9 ↗</td><td>11:</td><td>10.3 ↘</td></tr> <tr><td>2:</td><td>10.4x ↘</td><td>12:</td><td>10.5x ↘</td></tr> <tr><td>3:</td><td>9.7 ↙</td><td>13:</td><td>10.3x ↘</td></tr> <tr><td>4:</td><td>9.7 ↙</td><td>14:</td><td>10.3 ↗</td></tr> <tr><td>5:</td><td>9.9 ↗</td><td>15:</td><td>9.3 ↙</td></tr> <tr><td>6:</td><td>10.3x →</td><td></td><td></td></tr> <tr><td>7:</td><td>10.1 ↗</td><td></td><td></td></tr> <tr><td>8:</td><td>9.7 →</td><td></td><td></td></tr> <tr><td>9:</td><td>9.9 ↙</td><td></td><td></td></tr> <tr><td>10:</td><td>10.3x →</td><td></td><td></td></tr> <tr><td colspan="2">Serie 94.0</td><td colspan="2">Serie 49.0</td></tr> <tr><td colspan="2">Total 0.0</td><td colspan="2">Total 0.0</td></tr> </table>	1:	9.9 ↗	11:	10.3 ↘	2:	10.4x ↘	12:	10.5x ↘	3:	9.7 ↙	13:	10.3x ↘	4:	9.7 ↙	14:	10.3 ↗	5:	9.9 ↗	15:	9.3 ↙	6:	10.3x →			7:	10.1 ↗			8:	9.7 →			9:	9.9 ↙			10:	10.3x →			Serie 94.0		Serie 49.0		Total 0.0		Total 0.0	
1:	9.9 ↗	11:	10.3 ↘																																															
2:	10.4x ↘	12:	10.5x ↘																																															
3:	9.7 ↙	13:	10.3x ↘																																															
4:	9.7 ↙	14:	10.3 ↗																																															
5:	9.9 ↗	15:	9.3 ↙																																															
6:	10.3x →																																																	
7:	10.1 ↗																																																	
8:	9.7 →																																																	
9:	9.9 ↙																																																	
10:	10.3x →																																																	
Serie 94.0		Serie 49.0																																																
Total 0.0		Total 0.0																																																
<div style="text-align: center;">20 Skott</div> 	<div style="text-align: center;">20 Skott</div> 	<table style="width:100%; border-collapse: collapse;"> <tr><td>1:</td><td>9.8 ↙</td><td>6:</td><td>10.5x ↘</td></tr> <tr><td>2:</td><td>9.5 ↙</td><td>7:</td><td>9.1 ↓</td></tr> <tr><td>3:</td><td>10.0 ↙</td><td>8:</td><td>10.5x ↗</td></tr> <tr><td>4:</td><td>10.8x ↗</td><td>9:</td><td>10.5x →</td></tr> <tr><td>5:</td><td>10.3x →</td><td>10:</td><td>9.7 ↙</td></tr> <tr><td colspan="2">Serie 48.0</td><td colspan="2">Serie 48.0</td></tr> <tr><td colspan="2">Total 48.0</td><td colspan="2">Total 96.0</td></tr> </table>	1:	9.8 ↙	6:	10.5x ↘	2:	9.5 ↙	7:	9.1 ↓	3:	10.0 ↙	8:	10.5x ↗	4:	10.8x ↗	9:	10.5x →	5:	10.3x →	10:	9.7 ↙	Serie 48.0		Serie 48.0		Total 48.0		Total 96.0																					
1:	9.8 ↙	6:	10.5x ↘																																															
2:	9.5 ↙	7:	9.1 ↓																																															
3:	10.0 ↙	8:	10.5x ↗																																															
4:	10.8x ↗	9:	10.5x →																																															
5:	10.3x →	10:	9.7 ↙																																															
Serie 48.0		Serie 48.0																																																
Total 48.0		Total 96.0																																																
<div style="text-align: center;">20 Skott</div> 	<div style="text-align: center;">20 Skott</div> 	<table style="width:100%; border-collapse: collapse;"> <tr><td>11:</td><td>9.5 ↘</td><td>16:</td><td>10.1 ↙</td></tr> <tr><td>12:</td><td>10.1 ↗</td><td>17:</td><td>10.2 ↘</td></tr> <tr><td>13:</td><td>9.2 ↘</td><td>18:</td><td>10.8x ↘</td></tr> <tr><td>14:</td><td>9.5 ↘</td><td>19:</td><td>10.3x →</td></tr> <tr><td>15:</td><td>10.3 ↙</td><td>20:</td><td>10.5x →</td></tr> <tr><td colspan="2">Serie 47.0</td><td colspan="2">Serie 50.0</td></tr> <tr><td colspan="2">Total 143.0</td><td colspan="2">Total 193.0</td></tr> </table>	11:	9.5 ↘	16:	10.1 ↙	12:	10.1 ↗	17:	10.2 ↘	13:	9.2 ↘	18:	10.8x ↘	14:	9.5 ↘	19:	10.3x →	15:	10.3 ↙	20:	10.5x →	Serie 47.0		Serie 50.0		Total 143.0		Total 193.0																					
11:	9.5 ↘	16:	10.1 ↙																																															
12:	10.1 ↗	17:	10.2 ↘																																															
13:	9.2 ↘	18:	10.8x ↘																																															
14:	9.5 ↘	19:	10.3x →																																															
15:	10.3 ↙	20:	10.5x →																																															
Serie 47.0		Serie 50.0																																																
Total 143.0		Total 193.0																																																

<div style="text-align: center;">Prov</div>	<div style="text-align: center;">Prov</div>	
1: 8.9 ↘ 2: 9.8 ↘ 3: 8.1 ← 4: 10.0 ↓ 5: 9.2 ↑ 6: 9.6 → 7: 7.7 ↑ 8: 9.1 ↑ 9: 7.1 ↑ 10: 10.2 ↙	11: 7.6 ↓ 12: 7.0 ↓ 13: 9.2 ↙ 14: 9.0 ↓ 15: 10.7x↑	
Serie 86.0	Serie 42.0	
Total 0.0	Total 0.0	
<div style="text-align: center;">20 Skott</div>	<div style="text-align: center;">20 Skott</div>	
1: 9.5 ↘ 2: 10.4x↓ 3: 10.4x↑ 4: 9.9 ↘ 5: 8.5 ↙	6: 9.6 ↖ 7: 10.3x↑ 8: 10.4x↘ 9: 9.5 → 10: 9.5 ↓	
Serie 46.0	Serie 47.0	
Total 46.0	Total 93.0	
<div style="text-align: center;">20 Skott</div>	<div style="text-align: center;">20 Skott</div>	
11: 9.1 ↘ 12: 10.0 ↓ 13: 9.1 ↓ 14: 8.1 ↗ 15: 10.2 ↑	16: 6.3 ↙ 17: 8.6 ↑ 18: 10.9x↘ 19: 10.2 ← 20: 8.7 ↙	
Serie 46.0	Serie 42.0	
Total 139.0	Total 181.0	

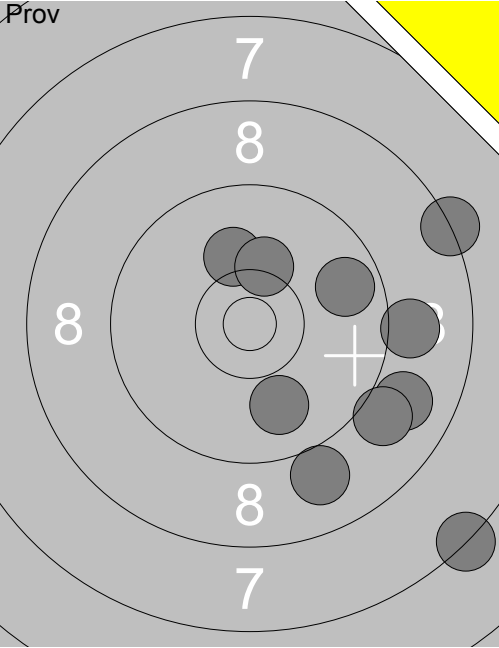
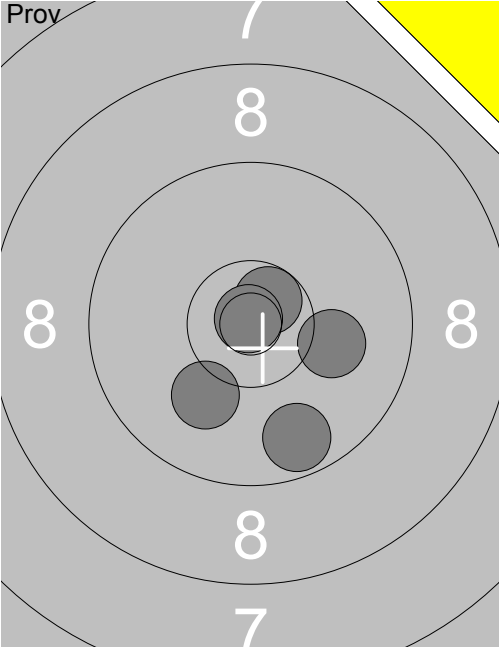
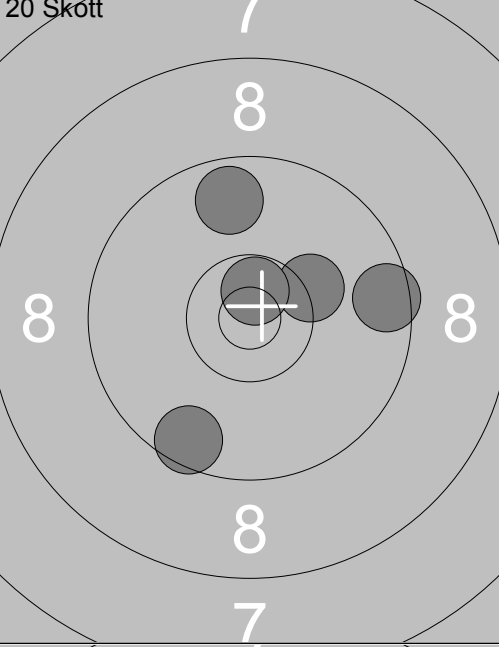
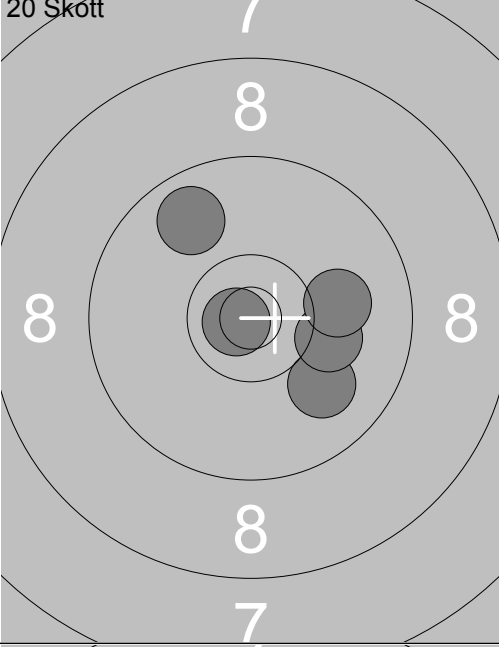
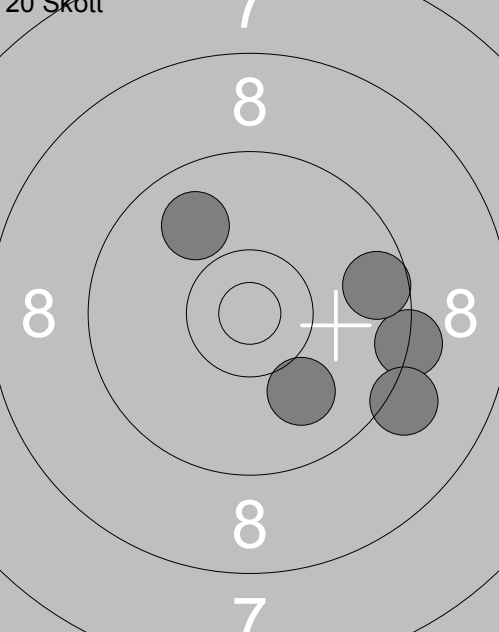
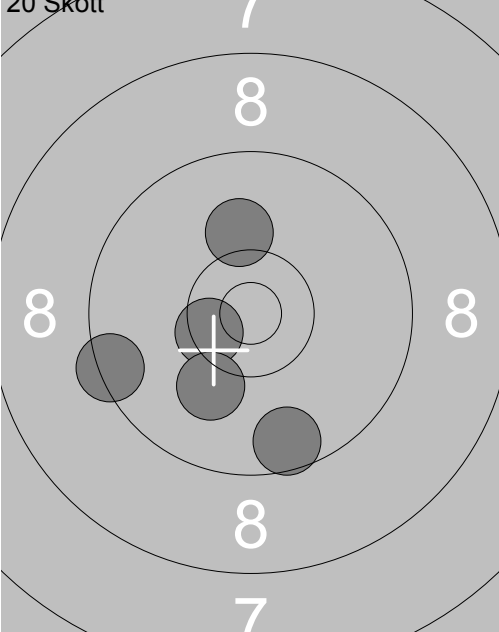
Skjuttag	Tavla	Berndt Steffen			
Vindeln	Frötuna	Vet-L		St	
11.07.2017	Tavelträffen Korthåll 2017	Ramselefors SKF			
	1: 7.3 ↘		11: 10.7x ↗		
	2: 9.9 ↘		12: 9.7 ↘		
	3: 8.9 ↘		13: 10.1 →		
	4: 9.0 ↘		14: 10.1 ↘		
	5: 9.0 ↘		15: 10.9x ↗		
	6: 10.1 ↑				
	7: 8.3 →				
	8: 9.7 →				
	9: 10.2 ↑				
	10: 9.0 →				
Serie	88.0	Serie	49.0		
Total	0.0	Total	0.0		
	1: 10.3 →		6: 9.8 ↖		
	2: 9.7 ↑		7: 10.0 ↘		
	3: 9.6 ↘		8: 10.8x ↖		
	4: 9.5 →		9: 10.1 →		
	5: 10.7x ↗		10: 10.1 →		
Serie	47.0	Serie	49.0		
Total	47.0	Total	96.0		
	11: 10.0 ↘		16: 9.6 ↘		
	12: 9.9 ↗		17: 9.4 ↖		
	13: 9.3 →		18: 10.5x ↖		
	14: 9.6 →		19: 10.1 ↘		
	15: 9.1 ↘		20: 10.1 ↑		
Serie	46.0	Serie	48.0		
Total	142.0	Total	190.0		

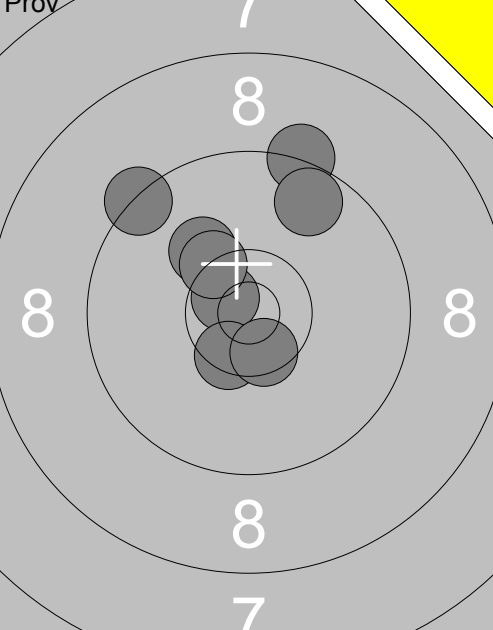
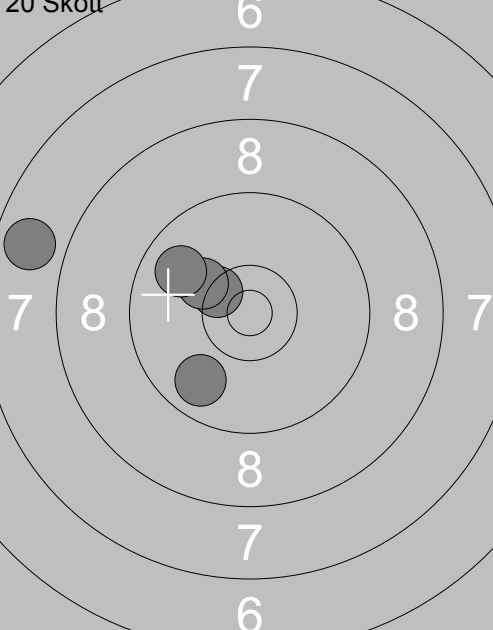
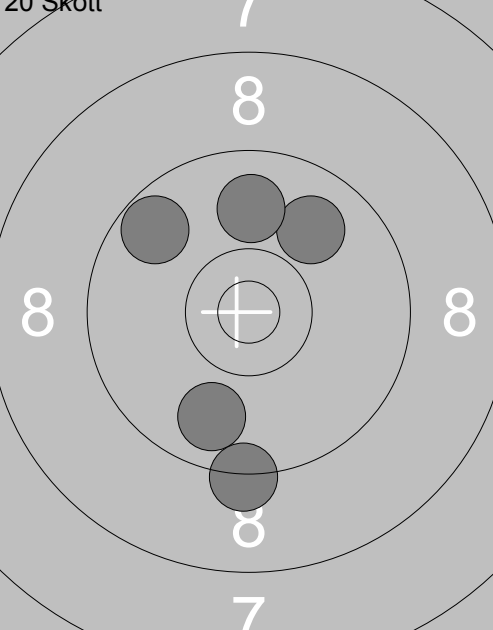
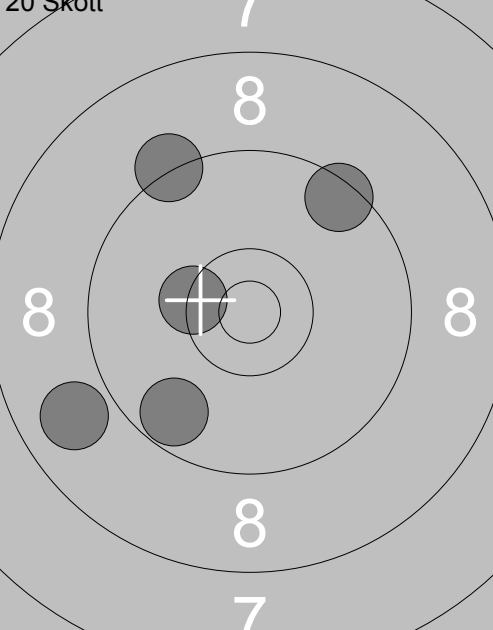
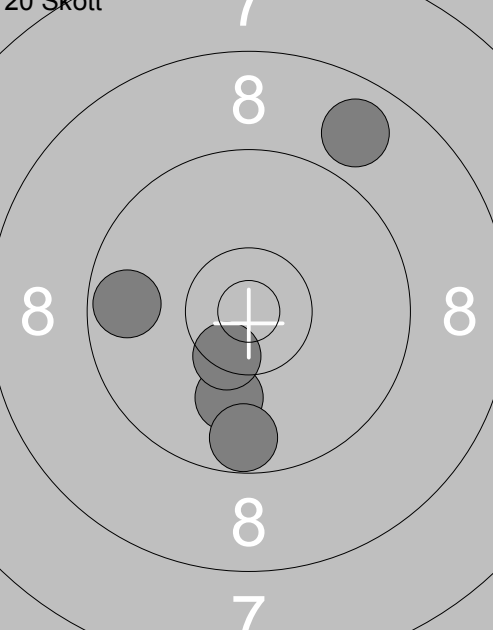
Prov 	20 Skott 	1: 9.3 ↗ 2: 9.7 ↗ 3: 10.2 ↘ 4: 10.7 ✕ 5: 10.3 ✕ 6: 9.4 ↖ 7: 10.5 ✕ 8: 10.5 ✕ Serie 77.0 Total 0.0	1: 7.8 ↖ 2: 10.4 ✕ 3: 9.8 ↘ 4: 10.2 ↖ 5: 9.8 ↖ Serie 45.0 Total 45.0
20 Skott 	20 Skott 	6: 9.7 ↖ 7: 9.9 ↗ 8: 9.8 ↘ 9: 9.9 ↗ 10: 9.3 ↘ Serie 45.0 Total 90.0	11: 9.5 ↗ 12: 9.3 ↘ 13: 10.4 ✕ 14: 9.7 ↘ 15: 8.9 ↖ Serie 45.0 Total 135.0
20 Skott 	16: 9.7 ↖ 17: 10.0 ↘ 18: 10.4 ✕ 19: 9.7 ↘ 20: 8.8 ↗ Serie 46.0 Total 181.0		

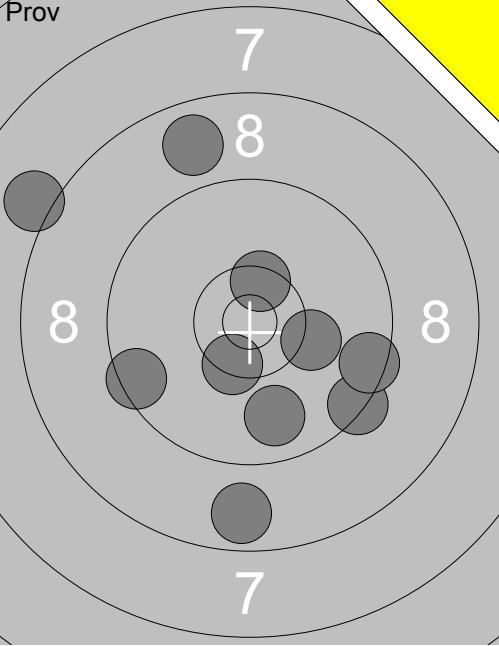
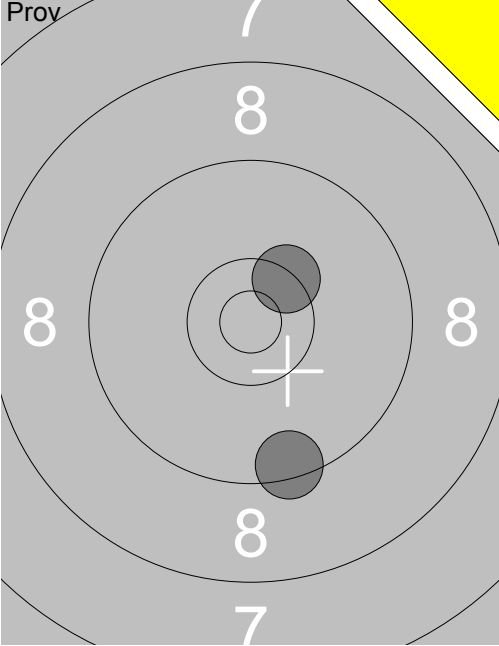
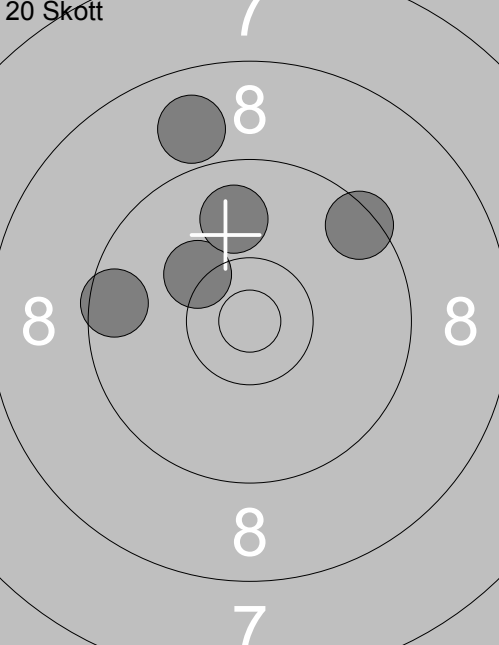
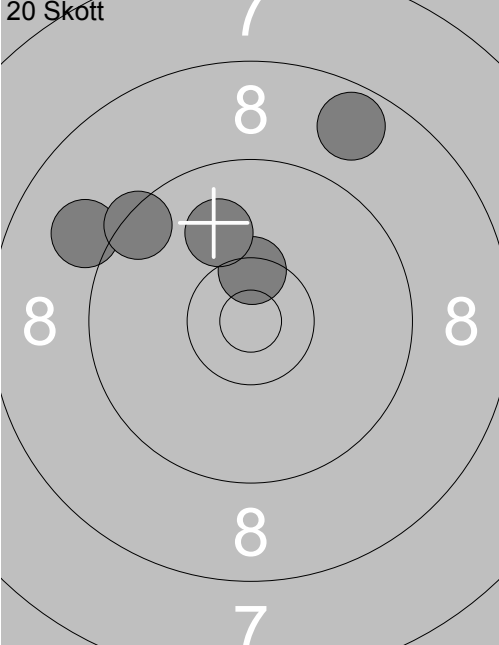
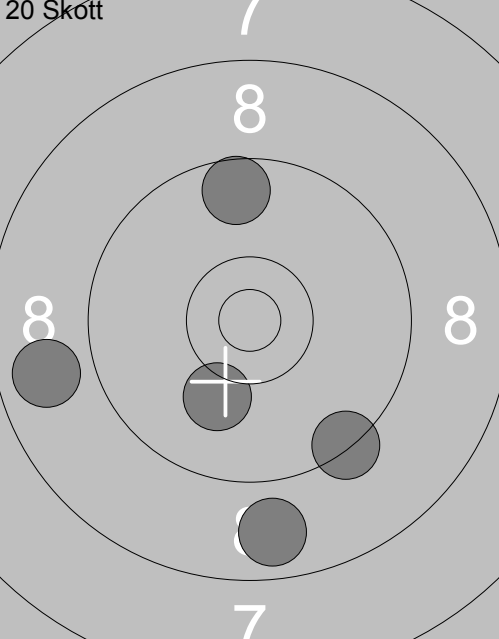
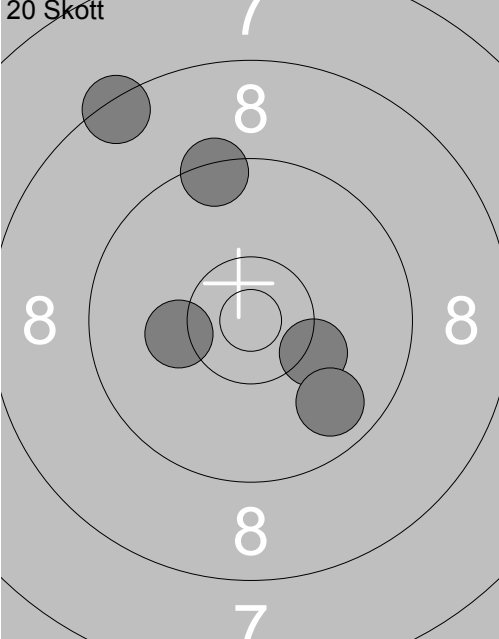
Skjutlag	Tavla	Bertil Ruisniemi			
5	18	Vindeln	Övertorneå	Vet-L	No
11.07.2017	Tavelträffen Korthåll 2017	Ramselefors SKF			
Prov		1: 8.1 ↖		11: 9.4 ↓	
		2: 8.8 ↑		12: 10.4x ↗	
		3: 9.5 ↙			
		4: 8.7 ↓			
		5: 9.8 ↓			
		6: 9.4 ↘			
		7: 9.5 →			
		8: 10.4x ↘			
		9: 10.5x ↗			
		10: 10.2 →			
	Serie 90.0		Serie 19.0		
	Total 0.0		Total 0.0		
20 Skott		1: 9.6 ↙		6: 10.4x ↗	
		2: 9.5 ↗		7: 8.7 ↗	
		3: 8.9 ↑		8: 10.0 ↑	
		4: 10.2 ↖		9: 9.0 ↙	
		5: 9.9 ↑		10: 9.4 ↙	
	Serie 45.0		Serie 46.0		
	Total 45.0		Total 91.0		
20 Skott		11: 8.8 ↙		16: 10.2 ↘	
		12: 8.8 ↓		17: 9.8 ↘	
		13: 10.1 ↘		18: 8.4 ↗	
		14: 9.6 ↑		19: 10.2 ↙	
		15: 9.3 ↘		20: 9.4 ↑	
	Serie 44.0		Serie 46.0		
	Total 135.0		Total 181.0		

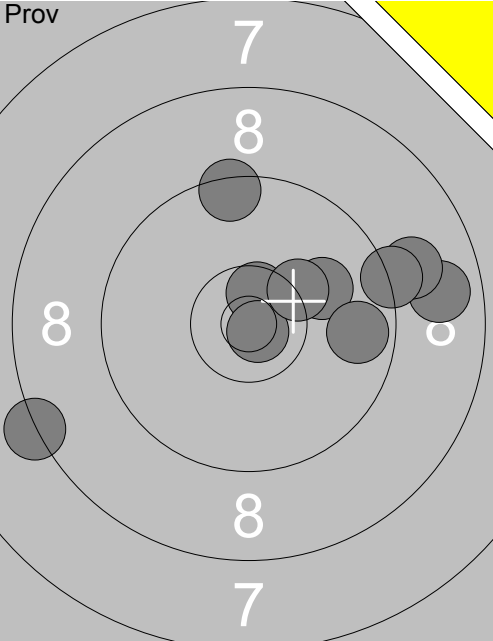
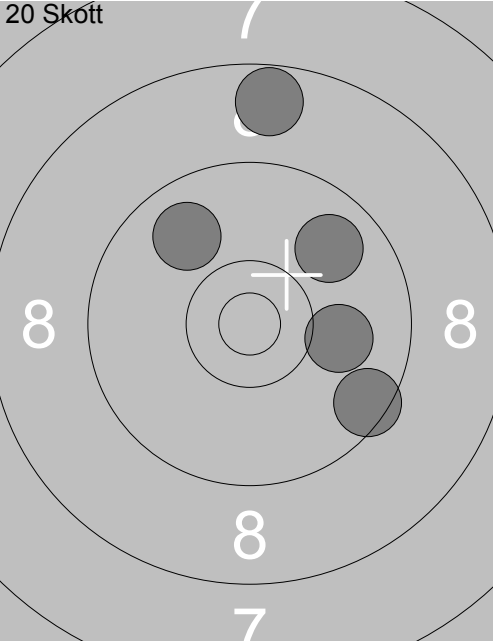
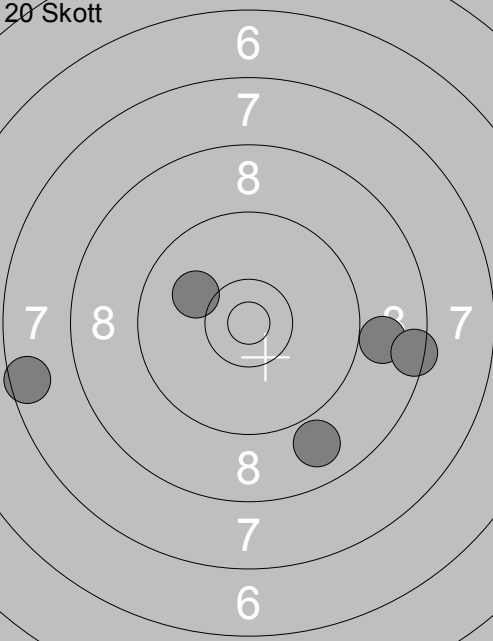
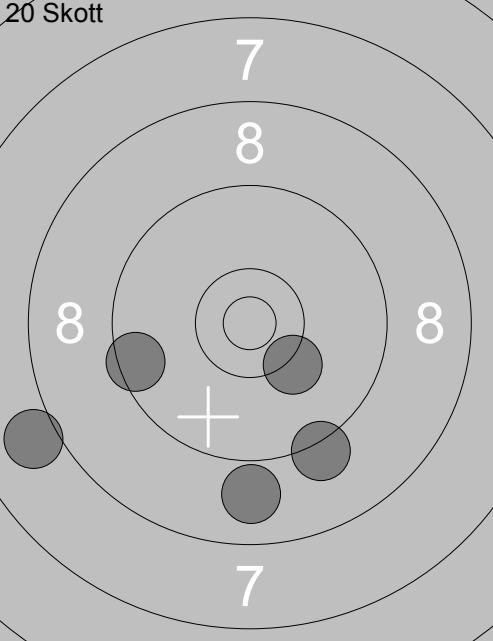
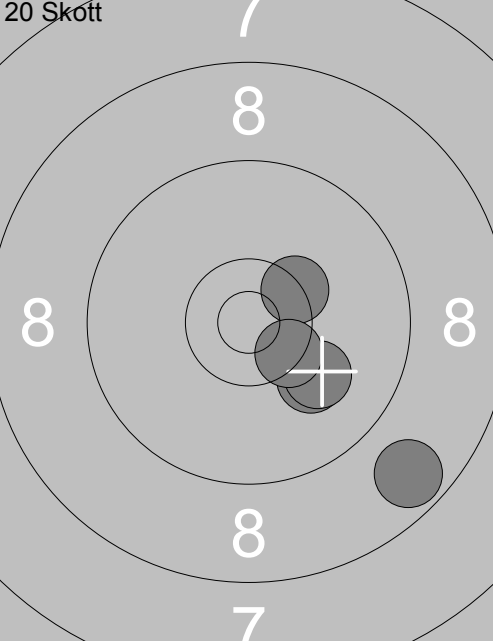
Skjutlag	Tavla	Bertil Omark		Vet-L	No
5	19				
Vindeln	Övertorneå				
11.07.2017	Tavelträffen Korthåll 2017		Ramselefors SKF		
Prov		1: 8.3 ← 2: 8.8 → 3: 10.6x↗ 4: 9.4 ↑ 5: 10.0 ↗ 6: 10.8x↘ 7: 9.0 → 8: 9.3 → 9: 9.7 → 10: 10.3 ↗ Serie 92.0 Total 0.0	20 Skott		1: 10.0 → 2: 9.5 ↘ 3: 9.9 ↖ 4: 9.8 ↗ 5: 8.7 ↑ Serie 45.0 Total 45.0
20 Skott		6: 8.9 → 7: 10.1 ↖ 8: 7.6 ← 9: 8.9 ↘ 10: 8.5 → Serie 41.0 Total 86.0	20 Skott		11: 9.2 ↘ 12: 9.5 ← 13: 8.9 ↓ 14: 10.2 ↘ 15: 8.0 ← Serie 44.0 Total 130.0
20 Skott		16: 10.1 ↘ 17: 10.1 ↘ 18: 10.4x↗ 19: 8.7 ↘ 20: 10.4x↘ Serie 48.0 Total 178.0			