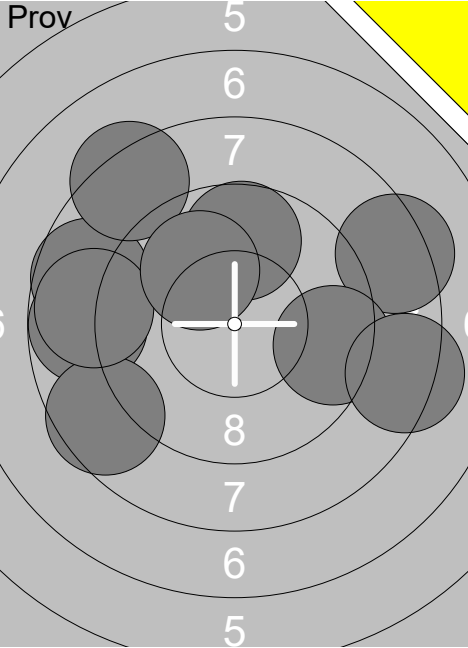
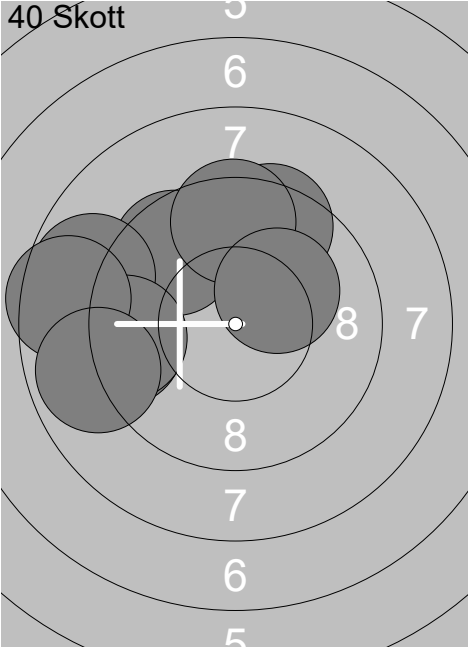
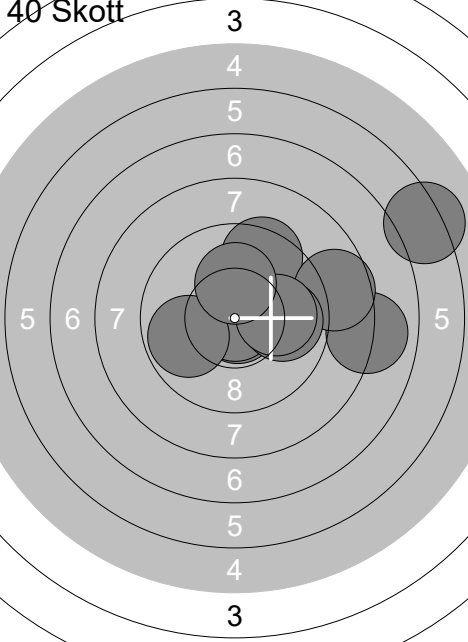
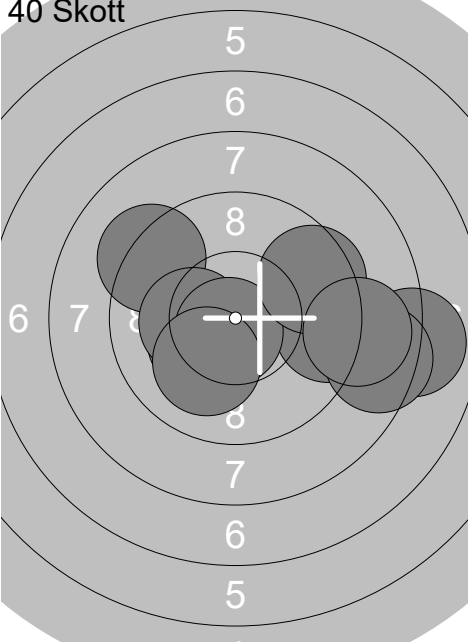
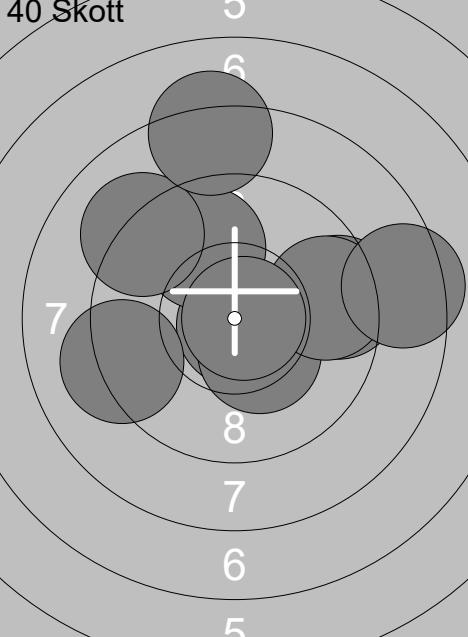
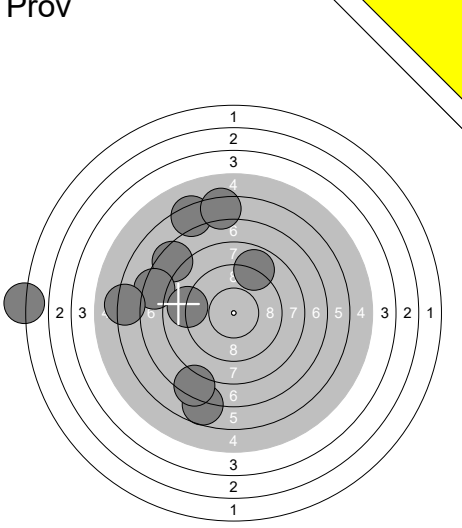
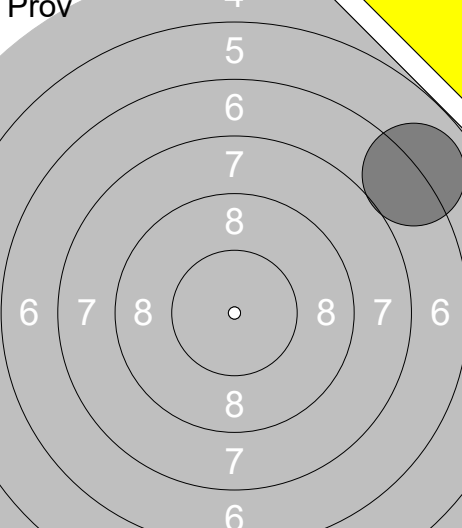

Skjuttag	Tavla	Amanda Hosseini		
1	11	Ramselefors	Ramselefors	7 Vb
04.11.2018	Vindelnskyttet 2018	Ramselefors SKF		
Prov 	1: 6.2 ↘ 2: 9.6 ↘ 3: 7.9 ↗ 4: 7.5 ↖ 5: 8.8 ← 6: 10.5x ↗ 7: 9.3 ↘ 8: 10.6x ← 9: 8.8 ↑ 10: 8.1 ↗	Prov 	11: 10.3x ↘	
	Serie 82		Serie 10	
	Total 0		Total 0	
40 Skott 	1: 10.5x ↑ 2: 10.5x ↑ 3: 6.2 ↘ 4: 7.1 ← 5: 9.5 ↗ 6: 10.0 → 7: 6.1 ↘ 8: 9.0 ↘ 9: 8.1 ↘ 10: 8.5 →	40 Skott 	11: 7.2 ↘ 12: 8.3 ↘ 13: 4.3 → 14: 9.0 ↘ 15: 6.4 ↘ 16: 9.1 ↑ 17: 9.5 ↘ 18: 7.3 → 19: 7.5 → 20: 8.2 ↘	
	Serie 83		Serie 74	
	Total 83		Total 157	
40 Skott 	21: 8.7 → 22: 9.0 ← 23: 10.5x ↑ 24: 9.0 ↗ 25: 7.1 ↘ 26: 8.5 ↘ 27: 8.1 ← 28: 8.0 ↘ 29: 7.4 → 30: 9.4 ←	40 Skott 	31: 8.5 ↗ 32: 9.2 ↘ 33: 7.2 → 34: 6.8 ↘ 35: 8.3 ↘ 36: 9.8 ↘ 37: 9.4 ↘ 38: 8.6 ← 39: 8.0 ↗ 40: 10.3x ↗	
	Serie 83		Serie 82	
	Total 240		Total 322	

Skjuttag	Tavla	Dennis Alenius			
1	12	Ramselefors	Ramselefors	7	Vb
04.11.2018	Vindelnskyttet 2018	Ramselefors SKF			
Prov 	1: 9.7 ↗	Prov 	11: 9.9 ↖		
	2: 9.8 ↗		12: 8.9 ←		
	3: 10.3x ↓		13: 9.9 ↑		
	4: 9.0 ↙		14: 10.2x →		
	5: 10.0 ←				
	6: 9.0 ↗				
	7: 10.2x ↑				
	8: 7.4 ↙				
	9: 9.4 ↑				
	10: 9.5 →				
	Serie 91		Serie 36		
	Total 0		Total 0		
40 Skott 	1: 10.1 ↘	40 Skott 	11: 9.9 ←		
	2: 10.1 ↑		12: 10.4x →		
	3: 9.7 ↘		13: 7.7 →		
	4: 6.2 ←		14: 8.4 ↘		
	5: 9.5 ↗		15: 9.9 ↗		
	6: 10.4x ←		16: 9.7 ←		
	7: 10.0 ←		17: 10.4x ↙		
	8: 10.6x ↙		18: 8.9 →		
	9: 9.9 ↘		19: 9.8 ↘		
	10: 9.5 ←		20: 9.4 ↙		
	Serie 92		Serie 88		
	Total 92		Total 180		
40 Skott 	21: 9.5 ←	40 Skott 	31: 10.6x ↓		
	22: 9.1 ↘		32: 9.6 ↗		
	23: 9.5 ↗		33: 10.5x ↗		
	24: 9.0 →		34: 10.6x ↑		
	25: 9.7 ↑		35: 10.7x ↘		
	26: 9.3 ↘		36: 9.6 ↘		
	27: 9.5 ←		37: 10.8x →		
	28: 9.1 ←		38: 8.8 →		
	29: 10.3x ↓		39: 10.7x →		
	30: 10.0 ↓		40: 9.4 ↙		
	Serie 92		Serie 95		
	Total 272		Total 367		

Skjutlag	Tavla	Ellen Alenius		
1	13	Ramselefors	Ramselefors	7 Vb
04.11.2018	Vindelnskyttet 2018	Ramselefors SKF		
Prov 	1: 8.3 → 2: 9.4 → 3: 8.7 ← 4: 8.8 ← 5: 8.6 ← 6: 8.8 ← 7: 8.3 ↗ 8: 8.3 → 9: 9.7 ↑ 10: 10.0 ↗ Serie 84 Total 0	40 Skott 	1: 9.1 ← 2: 9.6 ↖ 3: 9.5 ↗ 4: 9.5 ↑ 5: 10.2x ↗ 6: 8.8 ← 7: 9.3 ← 8: 9.4 ← 9: 8.5 ← 10: 8.9 ← Serie 88 Total 88	
40 Skott 	11: 10.8x ↓ 12: 9.5 ↗ 13: 8.0 → 14: 6.2 ↗ 15: 10.9x ↓ 16: 8.6 → 17: 9.9 → 18: 9.9 ← 19: 10.0 → 20: 10.2x ↑ Serie 89 Total 177	40 Skott 	21: 9.4 → 22: 9.2 ↖ 23: 10.3x ↙ 24: 8.0 → 25: 10.2x ← 26: 10.7x ↓ 27: 8.5 → 28: 10.1 ↓ 29: 9.5 ↗ 30: 8.9 → Serie 91 Total 268	
40 Skott 	31: 10.8x ↓ 32: 9.4 → 33: 10.3x ↓ 34: 9.8 ↗ 35: 9.2 ← 36: 9.1 ↗ 37: 8.2 ↑ 38: 9.6 → 39: 10.8x → 40: 8.5 → Serie 91 Total 359			

Skjuttag	Tavla	Erika Gustafsson	
1	14	Ramselefors	Vb
04.11.2018	Vindelnskyttet 2018	Ramselefors SKF	
Prov	40 Skott	40 Skott	40 Skott
	1: 9.6 ← 2: 10.5x ↘ 3: 9.7 ← 4: 10.4x → 5: 10.2x → 6: 10.6x →		1: 10.4x ↓ 2: 10.0 ↗ 3: 10.3x ↓ 4: 10.1 → 5: 10.3x ↓ 6: 10.4x ↓ 7: 9.6 ↖ 8: 10.8x ↓ 9: 10.6x ↗ 10: 10.1 ↗
	Serie 58		Serie 99
	Total 0		Total 99
40 Skott	40 Skott	40 Skott	40 Skott
	11: 9.5 ↗ 12: 10.4x ↖ 13: 10.6x ↓ 14: 10.3x ← 15: 10.6x ↗ 16: 0.0 → 17: 10.6x → 18: 10.0 ← 19: 10.0 ↑ 20: 10.2x ↗		21: 10.5x ↙ 22: 10.3x ↗ 23: 9.5 ← 24: 10.6x ↓ 25: 10.5x ← 26: 10.6x ↓ 27: 10.5x → 28: 10.8x ↓ 29: 10.6x ← 30: 10.5x ↖
	Serie 89		Serie 99
	Total 188		Total 287
40 Skott	40 Skott		
	31: 10.5x ↖ 32: 10.5x ↗ 33: 10.4x ↓ 34: 10.3x ↘ 35: 10.5x ↓ 36: 10.7x ↓ 37: 10.1 ↙ 38: 10.5x ↖ 39: 10.0 ↓ 40: 10.9x ↖		
	Serie 100		
	Total 387		

Prov 	1: 8.9 ↗ 2: 7.5 ↘ 3: 6.3 ↗ 4: 6.7 ↓ 5: 7.3 ← 6: 7.3 ↓ 7: 8.9 ← 8: 6.4 ↑ 9: 6.2 ← 10: 1.8 ← <hr/> Serie 62 Total 0	Prov 	11: 7.0 ↗ <hr/> Serie 7 Total 0
--	--	--	---------------------------------------

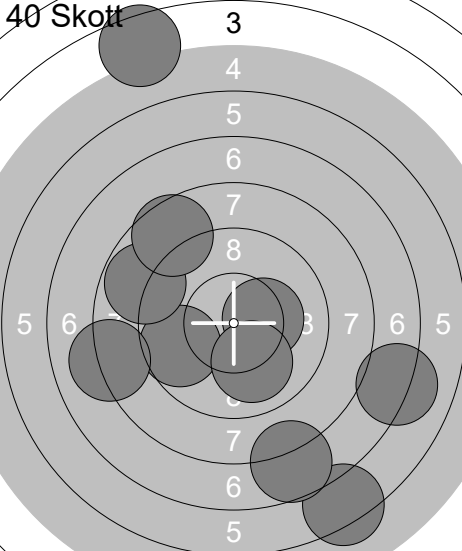
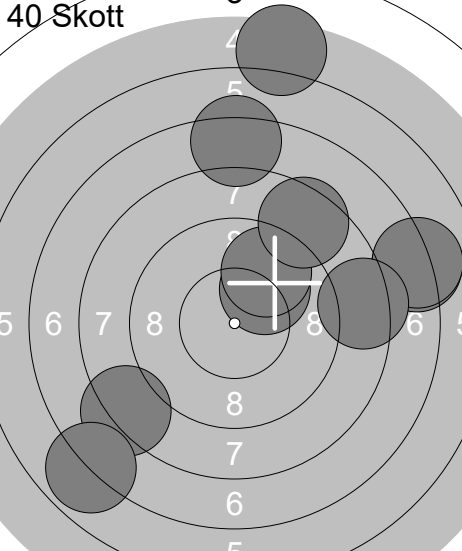
40 Skott 	1: 9.7 ← 2: 10.3x → 3: 10.0 ↓ 4: 7.1 → 5: 8.1 ← 6: 6.3 ↓ 7: 8.8 ↗ 8: 4.5 ↑ 9: 7.7 ↓ 10: 8.6 ↗ <hr/> Serie 77 Total 77	40 Skott 	11: 10.0 ↗ 12: 5.4 ↑ 13: 7.1 → 14: 9.7 ↗ 15: 7.3 ↑ 16: 7.1 → 17: 8.2 ↘ 18: 6.9 ↘ 19: 8.5 ↗ 20: 8.4 → <hr/> Serie 75 Total 152
---	--	---	--

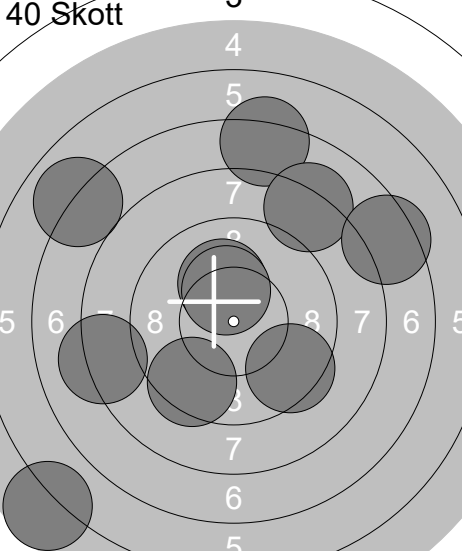
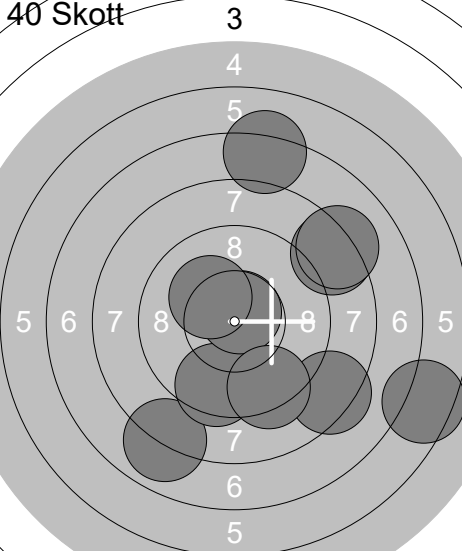
40 Skott 	21: 8.2 ← 22: 9.5 ↘ 23: 7.2 ↑ 24: 5.6 ↘ 25: 10.1 ↑ 26: 9.5 ↓ 27: 7.0 ↘ 28: 8.2 ↗ 29: 10.3x ↑ 30: 7.4 → <hr/> Serie 80 Total 232	40 Skott 	31: 7.2 ↑ 32: 8.0 ↓ 33: 6.5 → 34: 8.4 ↗ 35: 9.5 ↓ 36: 8.2 ↗ 37: 10.7x ↗ 38: 10.2x ↘ 39: 8.4 ↘ 40: 9.3 ↓ <hr/> Serie 83 Total 315
--	--	--	---

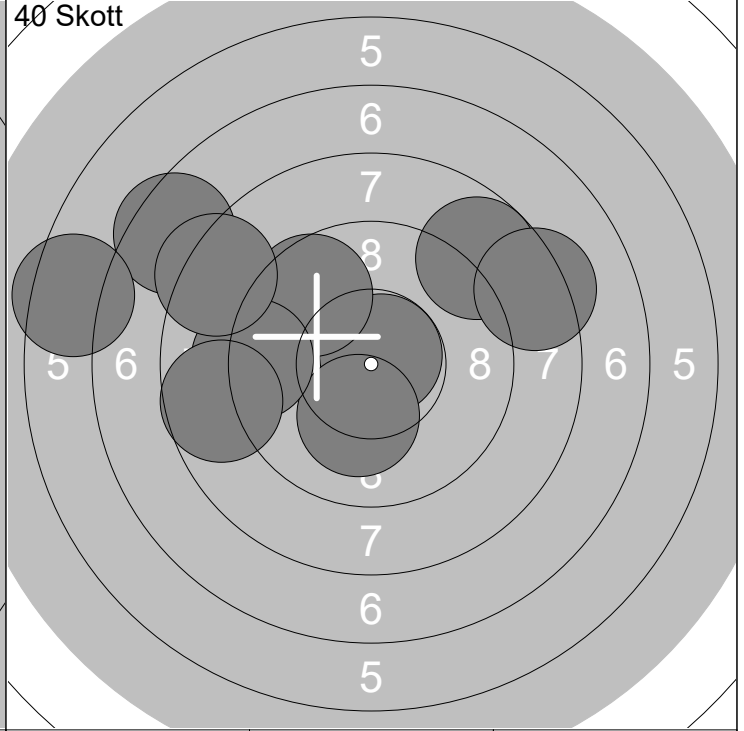
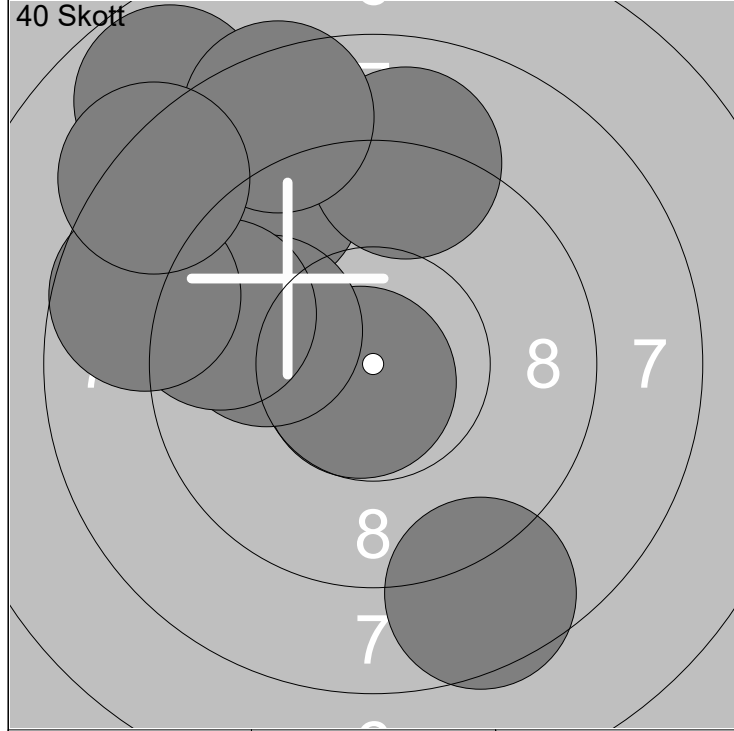

1: 7.8 ↖	6: 9.4 ←	Serie	85
2: 9.1 ↗	7: 9.0 ↑		
3: 10.7x ↘	8: 8.7 ←	Total	85
4: 9.9 ←	9: 8.5 ↑		
5: 8.6 ↘	10: 8.2 ↖		

11: 7.5 ↖	16: 10.2x ↓	Serie	83
12: 8.8 ↗	17: 6.5 ←		
13: 10.8x ↗	18: 9.2 ←	Total	168
14: 9.6 ↖	19: 8.7 ←		
15: 8.3 ↗	20: 8.3 ↖		

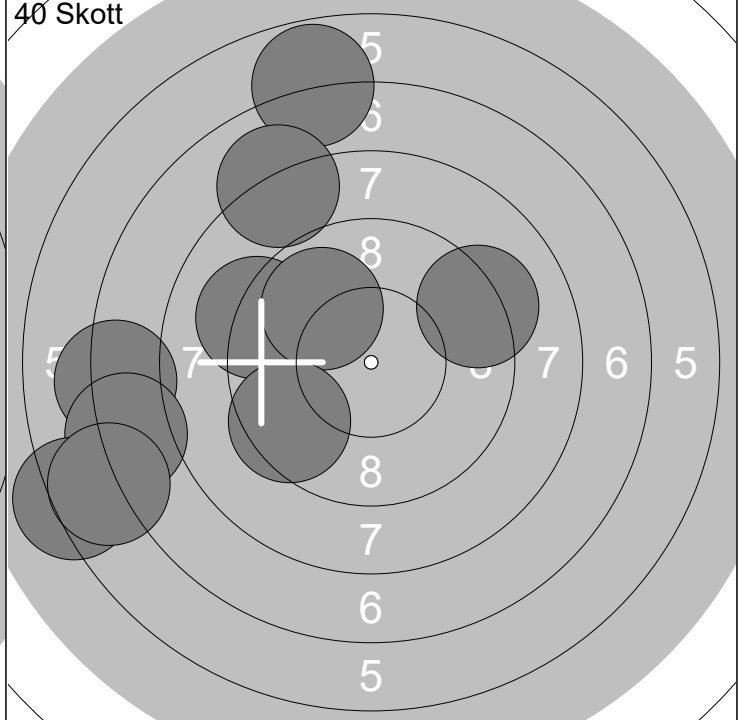
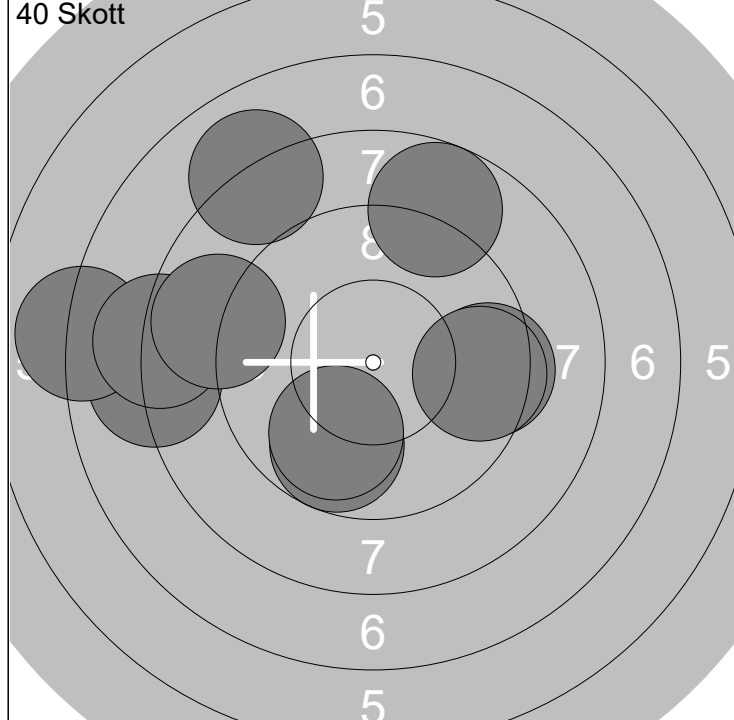

21: 8.0 ↖	26: 8.0 ←	Serie	83
22: 9.4 →	27: 7.0 ←		
23: 9.7 ↘	28: 8.1 ←	Total	251
24: 9.5 →	29: 8.8 ←		
25: 8.8 ↑	30: 9.9 ↘		

31: 9.2 ↖	36: 7.2 ←	Serie	76
32: 9.9 ↖	37: 9.5 ↘		
33: 9.2 ↗	38: 8.0 ↖	Total	327
34: 6.8 ↑	39: 6.2 ←		
35: 7.2 ←	40: 6.7 ←		

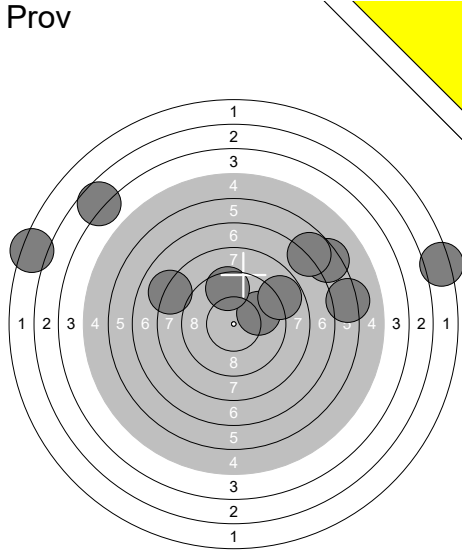
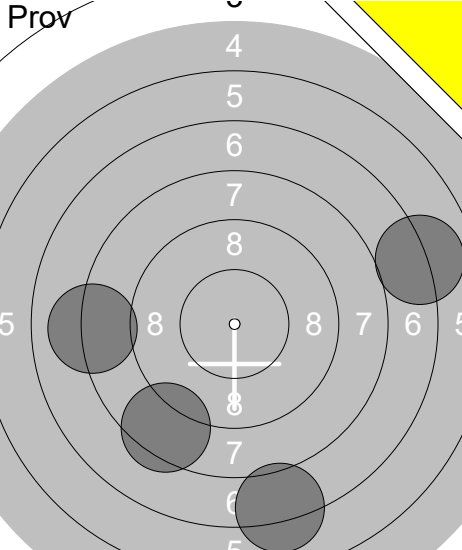
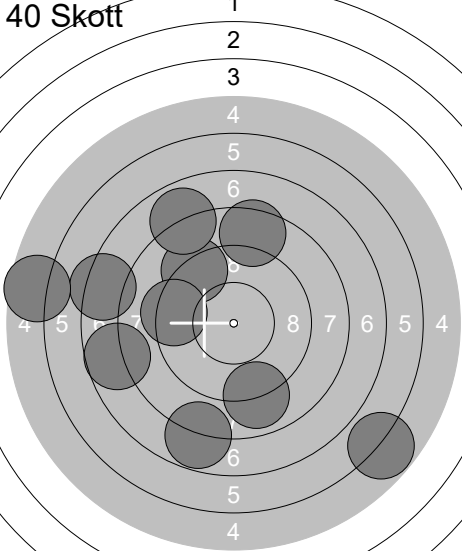
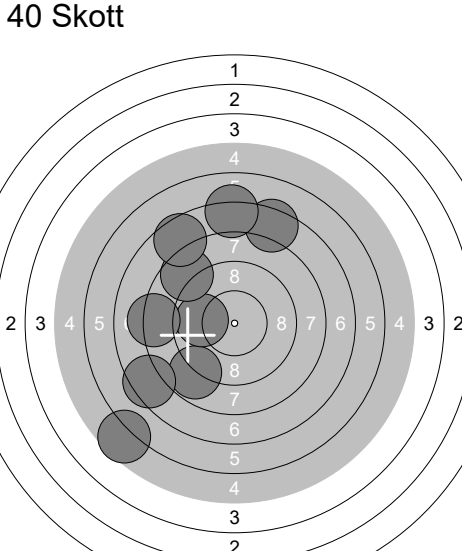
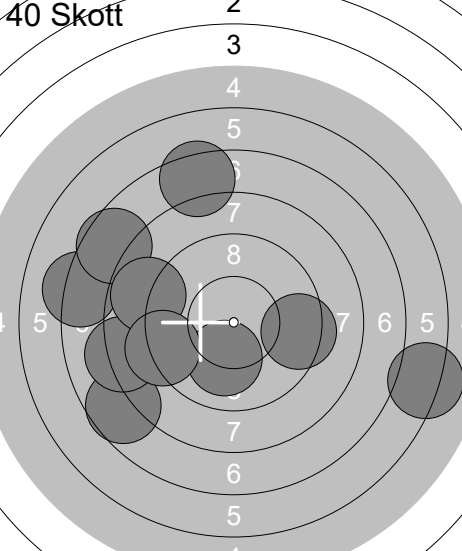
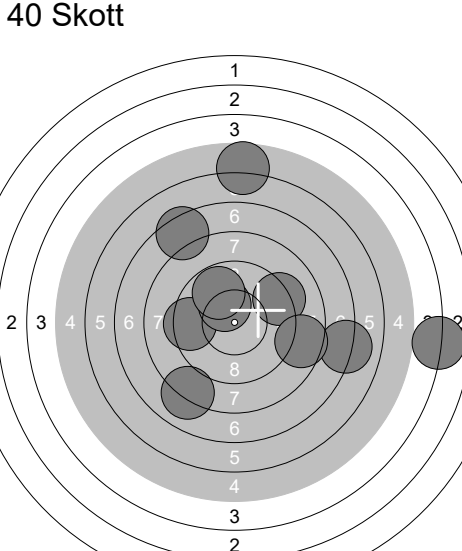
Skjuttag	Tavla	Samrawit Bereket	
1	17		
Ramselefors	Ramselefors	7	Vb
04.11.2018	Vindelnskyttet 2018	Ramselefors SKF	
Prov 	1: 9.8 →	Prov 	11: 8.4 ↘
	2: 2.2 ←		12: 7.1 ↓
	3: 3.6 ↗		13: 7.0 →
	4: 8.8 →		14: 8.1 ←
	5: 2.2 →		
	6: 6.2 →		
	7: 6.4 →		
	8: 9.5 ↑		
	9: 8.1 ←		
	10: 6.8 ↗		
	Serie 59		Serie 30
	Total 0		Total 0
40 Skott 	1: 5.8 ↘	40 Skott 	11: 8.8 ↘
	2: 9.2 ↗		12: 7.4 ↑
	3: 8.9 ↓		13: 9.8 ←
	4: 7.8 ↓		14: 7.2 ↑
	5: 7.7 ←		15: 7.4 ↘
	6: 7.3 ←		16: 8.2 ←
	7: 5.6 ←		17: 5.6 ↘
	8: 9.3 ←		18: 0.0 ↓
	9: 7.9 ↗		19: 8.7 ↘
	10: 8.5 ↑		20: 7.6 ↗
	Serie 72		Serie 66
	Total 72		Total 138
40 Skott 	21: 9.4 →	40 Skott 	31: 5.7 ↑
	22: 7.7 ↘		32: 9.2 →
	23: 6.2 →		33: 7.4 ↗
	24: 7.2 ←		34: 9.4 ←
	25: 7.4 ↑		35: 10.3x ↗
	26: 10.1 ↓		36: 4.0 →
	27: 7.6 ↘		37: 7.1 →
	28: 8.2 ←		38: 8.1 ↘
	29: 8.8 ←		39: 8.6 →
	30: 9.1 ←		40: 9.8 ↗
	Serie 78		Serie 76
	Total 216		Total 292

Skjutlag	Tavla	Ylva Lundstedt		
1	18	Ramselefors	Ramselefors	7 Vb
04.11.2018	Vindelnskyttet 2018	Ramselefors SKF		
Prov 	1: 10.7x ↙ 2: 10.4x ← 3: 10.3x ← 4: 10.4x ↘ 5: 9.7 ↙ 6: 10.6x → 7: 10.7x →	40 Skott 	1: 10.7x ↗ 2: 9.9 ↓ 3: 9.7 ↓ 4: 10.4x ← 5: 10.9x ↑ 6: 10.2x ↖ 7: 10.7x ↓ 8: 10.4x ↓ 9: 10.0 ↗ 10: 10.5x ↑	
	Serie 69		Serie 98	
	Total 0		Total 98	
40 Skott 	11: 10.2x ← 12: 10.4x ↗ 13: 10.3x ↗ 14: 9.1 ↘ 15: 10.5x ← 16: 10.0 ↗ 17: 10.3x → 18: 10.4x ← 19: 10.6x ↖ 20: 10.5x ↗	40 Skott 	21: 10.4x ↗ 22: 10.2x ↓ 23: 9.6 ↓ 24: 9.9 ← 25: 10.3x ↑ 26: 10.2x ↗ 27: 10.7x ↓ 28: 10.5x ↑ 29: 9.9 ↓ 30: 9.7 ↓	
	Serie 99		Serie 96	
	Total 197		Total 293	
40 Skott 	31: 10.1 ↙ 32: 8.7 ↓ 33: 9.7 ← 34: 9.4 → 35: 10.3x ↘ 36: 10.8x ↗ 37: 9.7 → 38: 9.8 ↘ 39: 9.5 ↗ 40: 9.9 ←			
	Serie 92			
	Total 385			

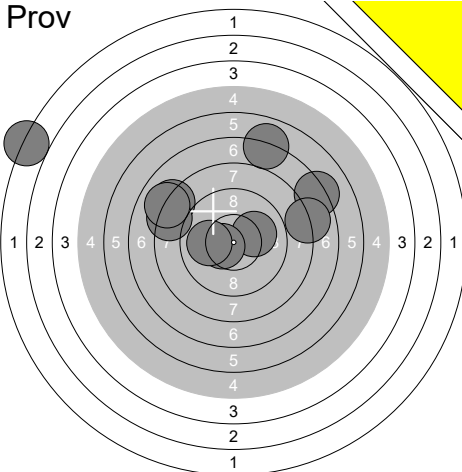
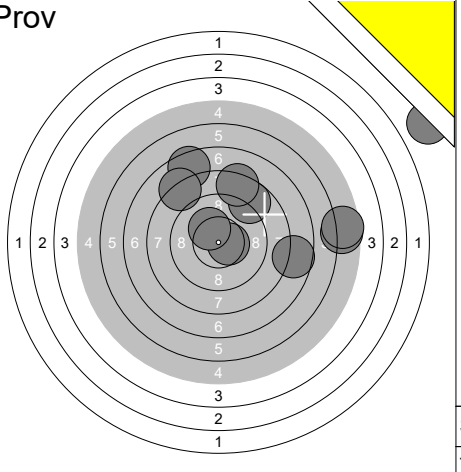
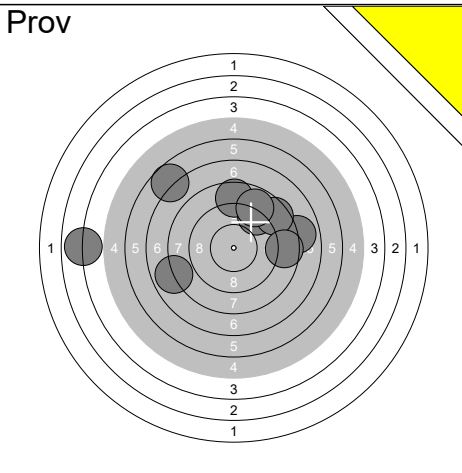
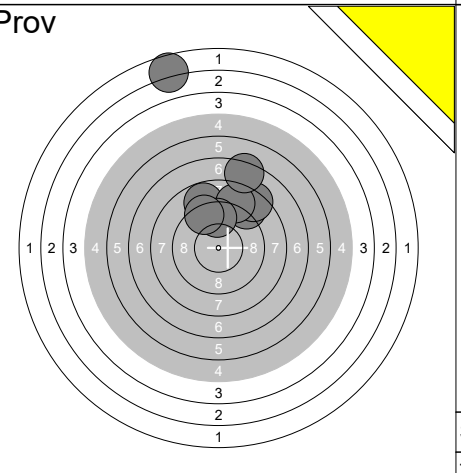
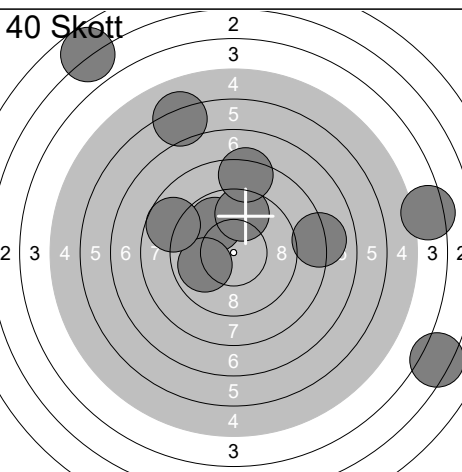
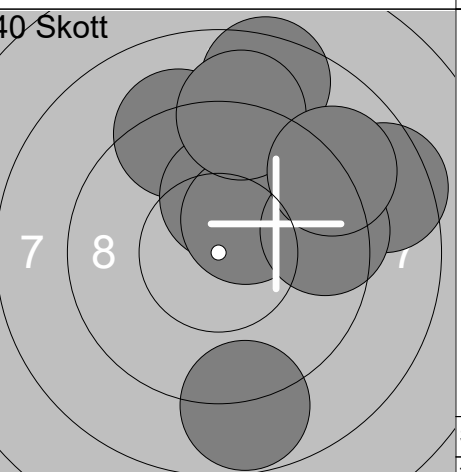
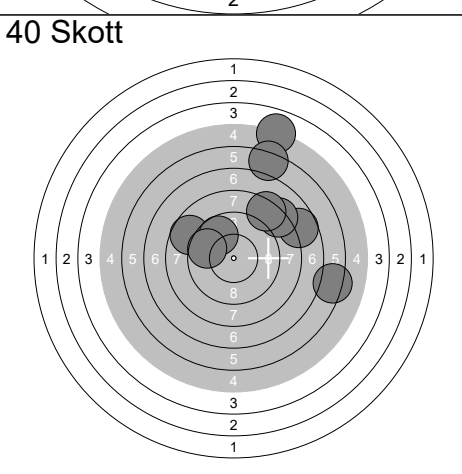
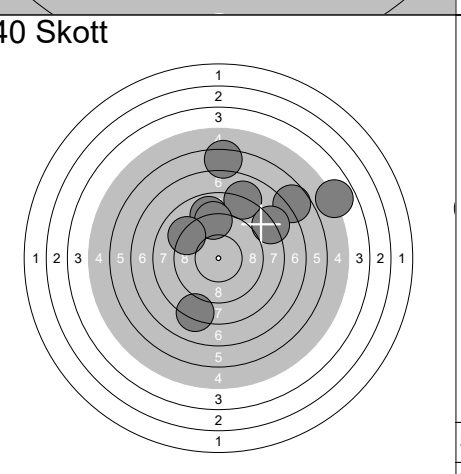
Skjuttag	Tavla	Elina Stivens	
1	19	Ramselefors	Vb
Ramselefors	Ramselefors	9	
04.11.2018	Vindelnskyttet 2018	Ramselefors SKF	
Prov 	1: 8.1 ↗ 2: 10.1 → 3: 7.0 ↗ 4: 8.3 ↗ 5: 7.2 → 6: 10.5x ← 7: 8.0 ↗ 8: 10.0 ← 9: 2.0 ↗ 10: 7.9 → Serie 77 Total 0	Prov 	11: 10.5x → 12: 8.8 ↗ 13: 7.7 → 14: 0.0 → 15: 5.6 → 16: 10.2x ↗ 17: 7.5 ↗ 18: 8.1 ↗ 19: 5.6 → 20: 8.3 ↗ Serie 68 Total 0
Prov 	21: 7.9 → 22: 7.9 ← 23: 8.6 ↗ 24: 9.1 ↗ 25: 8.5 ↗ 26: 6.7 ↗ 27: 8.6 → 28: 3.9 ← 29: 8.8 ↗ 30: 0.0 → Serie 64 Total 0	Prov 	31: 8.8 ↗ 32: 8.8 ↗ 33: 2.6 ↗ 34: 8.3 ↗ 35: 0.0 ↓ 36: 8.8 ↗ 37: 9.6 ↗ 38: 7.3 ↗ 39: 9.3 ↗ Serie 59 Total 0
40 Skott 	1: 8.1 → 2: 9.8 ↗ 3: 9.6 ↗ 4: 9.9 ← 5: 6.2 ↗ 6: 2.8 ↗ 7: 3.3 ↓ 8: 4.4 → 9: 8.7 ↗ 10: 8.3 ↗ Serie 66 Total 66	40 Skott 	11: 8.8 ↓ 12: 9.2 ↗ 13: 10.2x ↗ 14: 9.4 → 15: 8.5 ↗ 16: 10.4x ↗ 17: 8.5 → 18: 9.4 → 19: 9.0 ↗ 20: 9.0 ↗ Serie 89 Total 155
40 Skott 	21: 8.7 ↗ 22: 7.7 → 23: 6.3 → 24: 8.2 ↗ 25: 8.3 ↗ 26: 5.0 ↗ 27: 6.2 ↗ 28: 9.7 ↗ 29: 0.0 ↓ 30: 9.6 ↗ Serie 66 Total 221	40 Skott 	31: 4.8 → 32: 8.2 ↓ 33: 6.3 ↗ 34: 6.7 ↗ 35: 8.9 ↗ 36: 8.0 ↗ 37: 9.2 ↗ 38: 0.0 → 39: 8.0 → 40: 9.1 ↗ Serie 66 Total 287

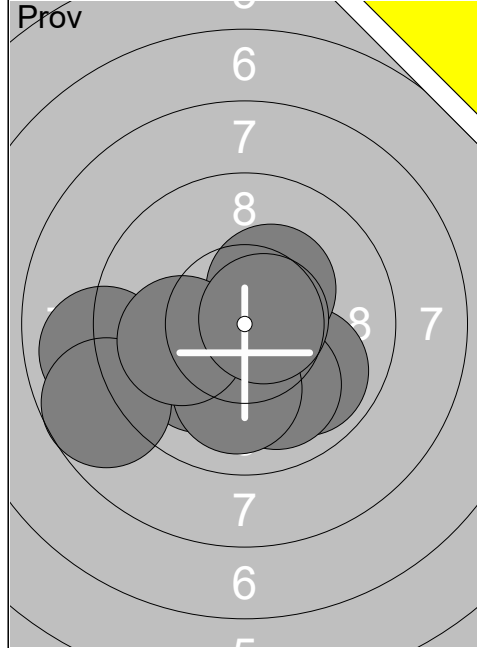

1:	9.9	↘
2:	10.3x	↗
3:	9.0	←
4:	10.1	↙
5:	8.7	↙
7:	10.0	↘
8:	10.0	↘
9:	10.1	←
10:	10.7x	→
Serie		86
Total		0

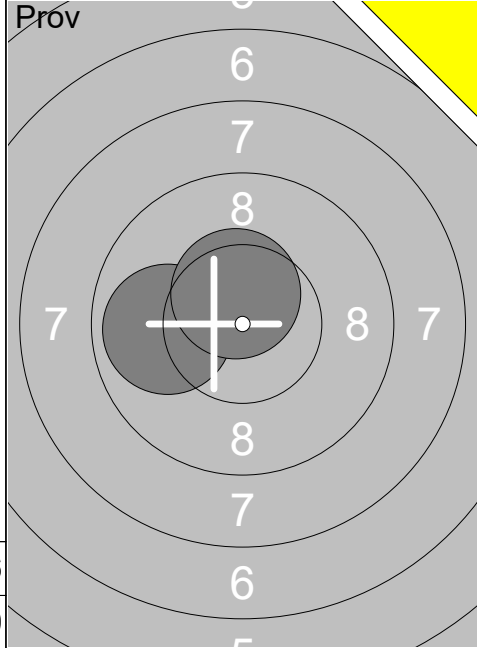

11:	9.9	←
12:	10.5x	↗
Serie		19
Total		0

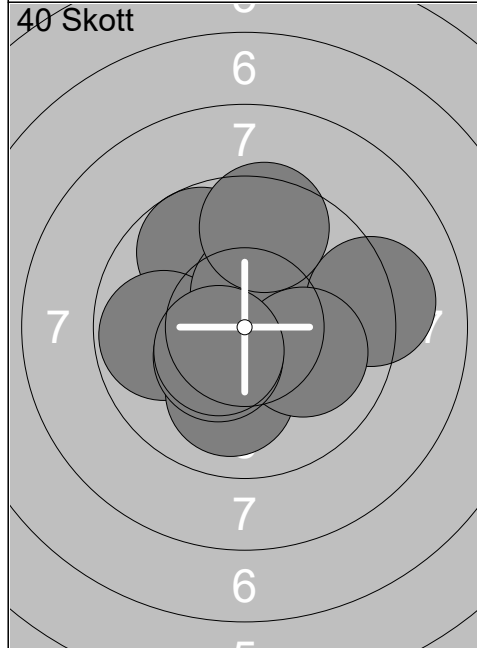

1:	10.1	→
2:	9.7	↗
3:	9.8	←
4:	10.0	↘
5:	10.5x	↗
6:	9.2	→
7:	10.1	→
8:	10.4x	↙
9:	9.5	↗
10:	10.5x	↙
Serie		96
Total		96

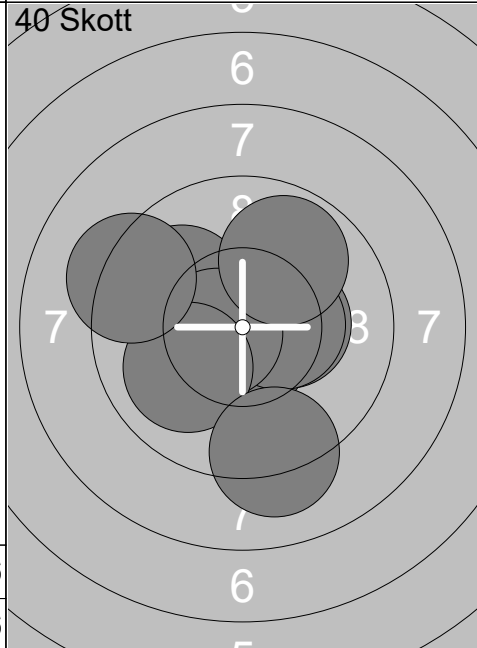

11:	10.0	↖
12:	10.3x	→
13:	10.7x	↘
14:	10.7x	→
15:	10.4x	→
16:	10.6x	←
17:	10.0	↙
18:	9.9	↗
19:	9.2	↘
20:	9.3	↖
Serie		97
Total		193

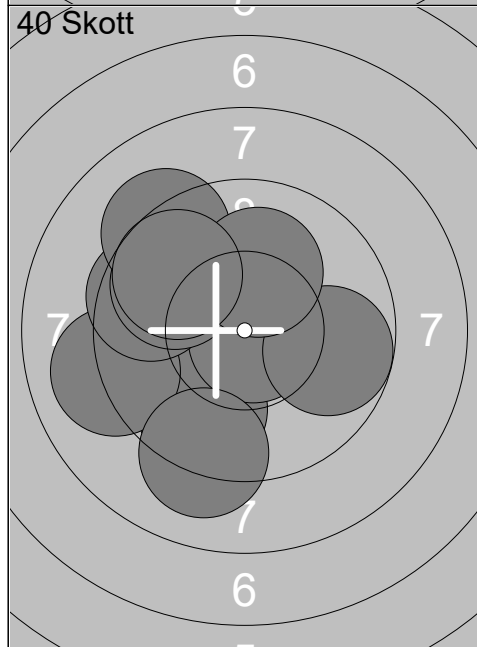

21:	9.7	↘
22:	10.8x	↘
23:	9.1	←
24:	9.6	←
25:	9.8	↗
26:	9.2	↘
27:	9.2	↗
28:	9.8	→
29:	10.1	↗
30:	9.7	↖
Serie		92
Total		285

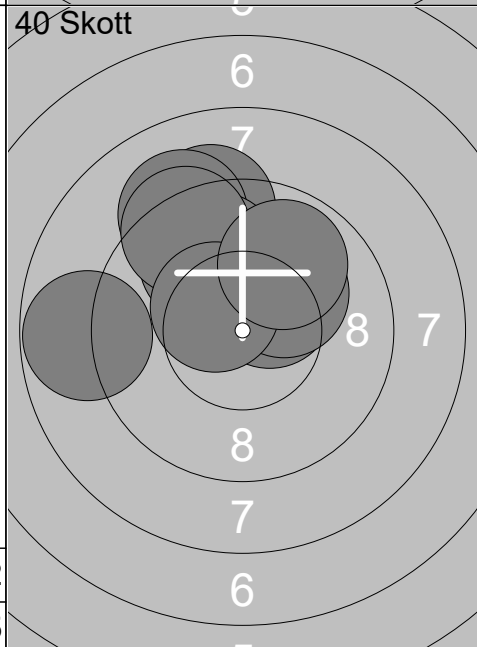

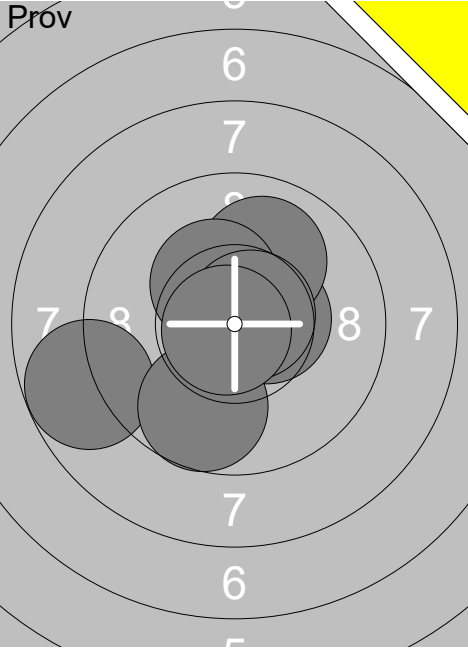
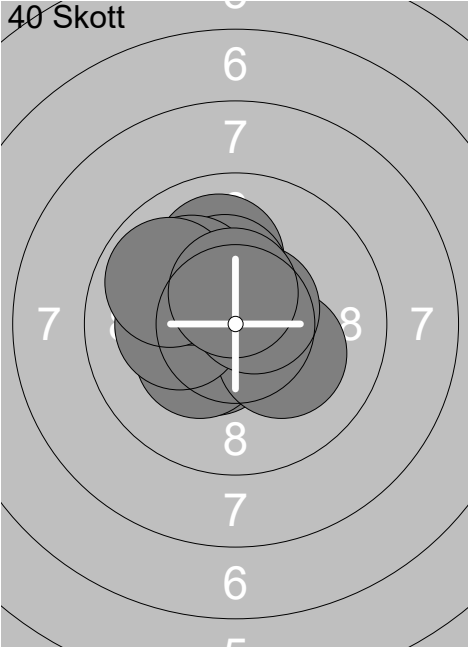
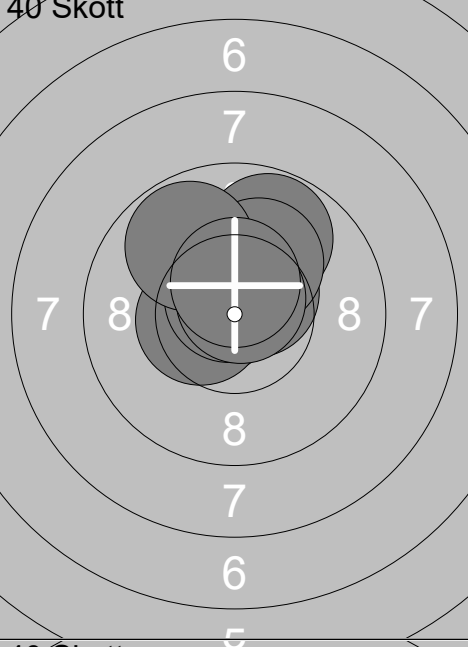
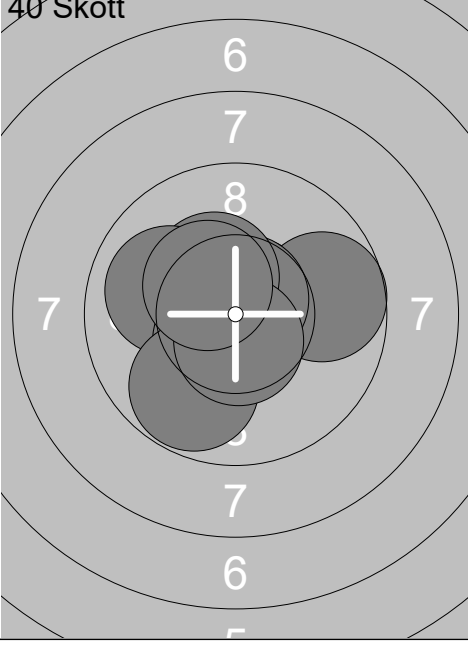
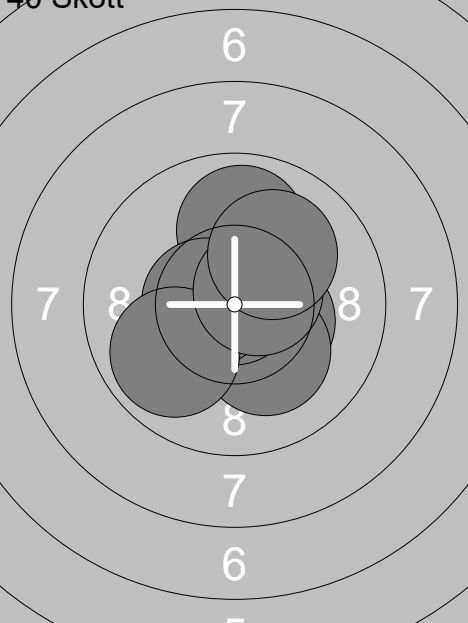

31:	9.8	↗
32:	8.8	←
33:	10.4x	↗
34:	9.2	↗
35:	9.1	↗
36:	9.9	↗
37:	9.4	↗
38:	10.2x	↗
39:	10.5x	↖
40:	9.9	↗
Serie		92
Total		377

Skjutlag	Tavla	Linus Lind		
1	22	Ramselefors	Skoga-Ekshärad	9 Vä
04.11.2018	Vindelnskyttet 2018	Ramselefors SKF		
Prov 	1: 10.9x → 2: 9.7 ↙ 3: 10.5x ↘ 4: 9.6 ↘ 5: 10.7x ↗ 6: 10.4x ← 7: 9.9 ↖ 8: 10.2x → 9: 10.2x ↗ 10: 10.6x ↗	Prov 	11: 10.5x ↘	
	Serie 97		Serie 10	
	Total 0		Total 0	
40 Skott 	1: 10.2x ↘ 2: 10.6x ↘ 3: 9.9 ↑ 4: 10.3x ↙ 5: 10.5x ↑ 6: 10.7x ↑ 7: 9.9 ↑ 8: 10.4x ← 9: 10.6x ← 10: 10.4x →	40 Skott 	11: 10.6x ← 12: 10.1 ↑ 13: 10.5x ← 14: 10.4x ↗ 15: 9.8 ← 16: 10.1 ← 17: 10.1 ↖ 18: 10.3x ← 19: 10.7x ← 20: 10.5x ↑	
	Serie 98		Serie 99	
	Total 98		Total 197	
40 Skott 	21: 9.8 ↑ 22: 9.9 → 23: 10.6x ↘ 24: 10.3x ↑ 25: 10.5x ↑ 26: 10.2x ↑ 27: 10.0 ↑ 28: 10.3x ↖ 29: 9.9 ↘ 30: 10.6x →	40 Skott 	31: 10.5x ↘ 32: 10.1 ← 33: 9.1 ← 34: 10.8x ↗ 35: 10.8x ↖ 36: 10.5x ← 37: 9.3 ← 38: 10.1 ↗ 39: 10.4x ↗ 40: 10.9x ←	
	Serie 97		Serie 98	
	Total 294		Total 392	

Skjutlag 1	Tavla 23	Vilhelm Lundstedt		
Ramselefors	Ramselefors	11	Vb	
04.11.2018	Vindelnskyttet 2018	Ramselefors SKF		
Prov 	1: 8.8 ← 2: 10.5x → 3: 10.0 ↗ 4: 10.3x ↖ 5: 9.7 ↓ 6: 10.7x ↗ 7: 10.8x ↙	40 Skott 	1: 10.5x ↙ 2: 10.3x ↙ 3: 10.2x ↘ 4: 10.2x ← 5: 10.6x ↗ 6: 10.0 ↑ 7: 10.3x ↑ 8: 10.1 ↖ 9: 9.9 ↖ 10: 10.5x ↑	
	Serie 67		Serie 99	
	Total 0		Total 99	
40 Skott 	11: 10.2x ↖ 12: 10.6x ← 13: 10.5x ↗ 14: 9.8 ↗ 15: 10.5x ← 16: 10.2x ↗ 17: 10.7x ↗ 18: 9.8 ↖ 19: 10.7x ↗ 20: 10.5x ↑	40 Skott 	21: 10.7x ↗ 22: 10.5x ↙ 23: 9.7 → 24: 10.7x ↗ 25: 10.4x ↖ 26: 10.0 ← 27: 10.5x ↙ 28: 9.8 ↓ 29: 10.6x ↓ 30: 10.4x ↖	
	Serie 98		Serie 98	
	Total 197		Total 295	
40 Skott 	31: 10.7x ↗ 32: 10.4x ↘ 33: 10.4x ↑ 34: 9.9 ↑ 35: 10.2x ↘ 36: 10.9x ↗ 37: 10.6x ← 38: 9.9 ↙ 39: 10.6x ↗ 40: 10.1 ↗			
	Serie 98			
	Total 393			

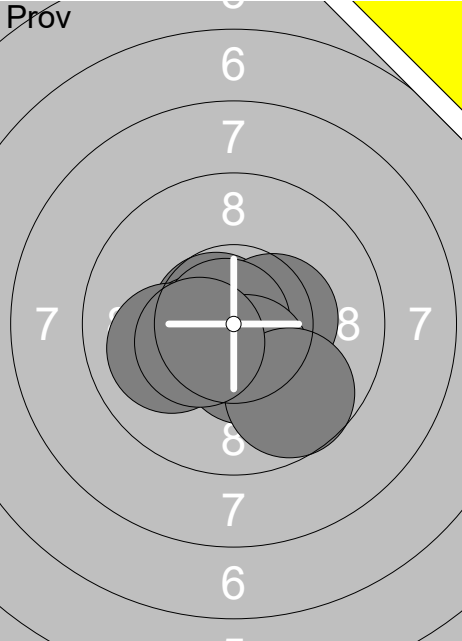

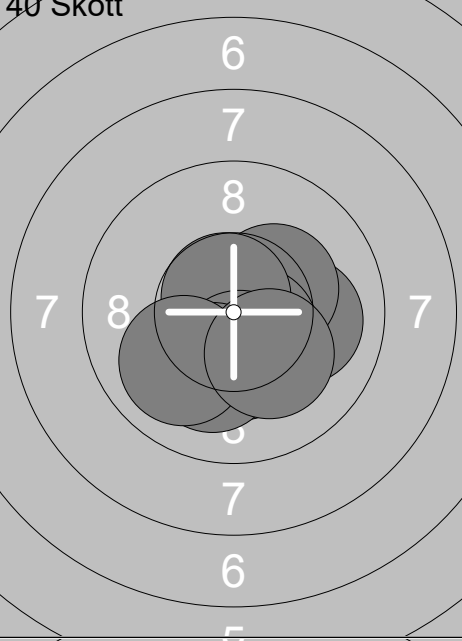
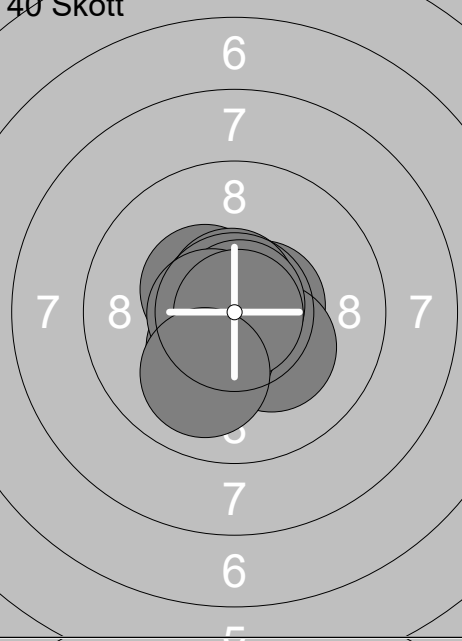
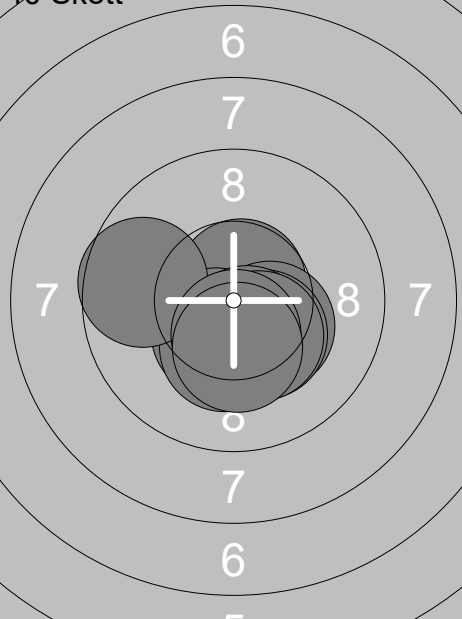
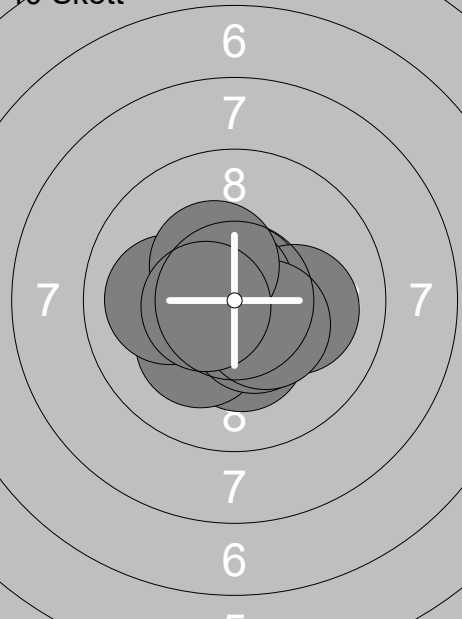
Skjuttag 1	Tavla 24	Alfred Nybom		
Ramselefors	Ramselefors	11	Vb	
04.11.2018	Vindelnskyttet 2018	Ramselefors SKF		
Pröv 	1: 10.4x ↗ 2: 9.0 ↗ 3: 10.3x ← 4: 9.9 ← 5: 9.2 ↗ 6: 10.7x → 7: 9.7 ↗ 8: 10.4x ↗ 9: 9.8 ↗ 10: 9.9 ↗ Serie 94 Total 0	Pröv 	11: 8.8 → 12: 9.3 ← 13: 9.3 → 14: 10.0 ↗ 15: 10.1 ↗ 16: 9.5 ↗ 17: 10.2x → 18: 9.8 ↗ 19: 10.6x ↓ Serie 84 Total 0	
Pröv 	21: 9.9 ← Serie 9 Total 0	40 Skott 	1: 9.6 ↗ 2: 10.3x → 3: 9.5 ↗ 4: 9.8 → 5: 10.4x ↓ 6: 9.8 ↓ 7: 10.4x ↓ 8: 10.0 ↗ 9: 10.2x ← 10: 10.6x ↗ Serie 96 Total 96	
40 Skott 	11: 9.6 ← 12: 10.8x ↗ 13: 10.5x ← 14: 10.2x ↗ 15: 10.6x → 16: 10.4x ↗ 17: 10.2x → 18: 10.4x ← 19: 10.5x ↗ 20: 10.6x ← Serie 99 Total 195	40 Skott 	21: 10.3x ↗ 22: 10.7x ↗ 23: 7.5 → 24: 10.2x ↓ 25: 10.4x ↗ 26: 10.1 ↗ 27: 10.4x ← 28: 10.6x ↗ 29: 10.1 ↗ 30: 10.3x ← Serie 97 Total 292	
40 Skott 	31: 10.4x ← 32: 10.2x → 33: 10.2x ↓ 34: 10.3x → 35: 10.1 ↗ 36: 9.5 → 37: 10.0 ↗ 38: 10.4x ↗ 39: 10.2x ↗ 40: 10.6x ↗ Serie 99 Total 391			

Skjuttag	Tavla	Tilda Rosendahl		
1	25	Ramselefors	11	Vb
04.11.2018	Vindelnskyttet 2018	Ramselefors SKF		
Prov 	1: 10.7x ↙	Prov 	11: 10.5x ↙	
	2: 10.7x →		12: 10.9x ↙	
	3: 10.4x ↙			
	4: 10.4x →			
	5: 10.0 ↙			
	6: 10.6x ↓			
	7: 10.8x ↙			
	8: 10.4x ↓			
	9: 9.7 ↓			
	10: 10.4x ↙			
	Serie 99		Serie 20	
	Total 0		Total 0	
40 Skott 	1: 10.4x ↓	40 Skott 	11: 10.4x ↖	
	2: 10.1 →		12: 10.5x ↓	
	3: 10.4x ↓		13: 10.6x →	
	4: 10.3x ↗		14: 10.7x ↑	
	5: 10.6x ↓		15: 10.2x ↓	
	6: 10.7x ↗		16: 10.8x ↗	
	7: 10.3x ↓		17: 10.4x ↓	
	8: 10.1 ↓		18: 10.6x ↙	
	9: 10.0 ↙		19: 10.9x →	
	10: 10.2x ↓		20: 10.0 ↓	
	Serie 100		Serie 100	
	Total 100		Total 200	
40 Skott 	21: 10.7x ↗	40 Skott 	31: 10.3x ↓	
	22: 10.3x ↘		32: 10.2x ↙	
	23: 10.4x ↓		33: 10.8x ↗	
	24: 10.3x ↓		34: 10.1 →	
	25: 9.7 ↙		35: 10.5x ↓	
	26: 10.3x ↓		36: 10.0 ↙	
	27: 10.5x ↓		37: 10.8x ↗	
	28: 10.3x ↓		38: 10.4x ↘	
	29: 10.5x ↓		39: 10.4x ↗	
	30: 10.3x ↓		40: 10.5x ↙	
	Serie 99		Serie 100	
	Total 299		Total 399	

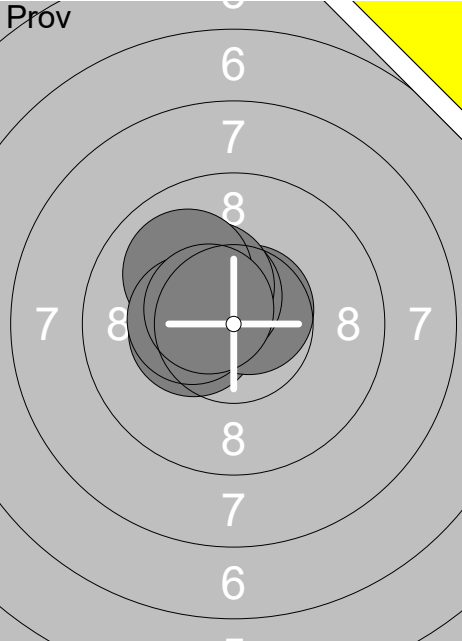
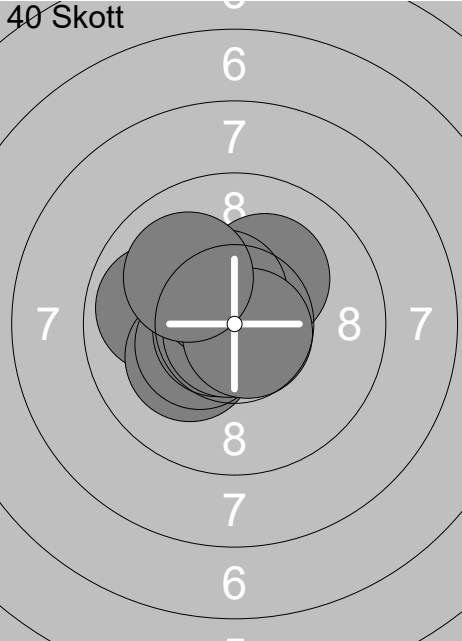
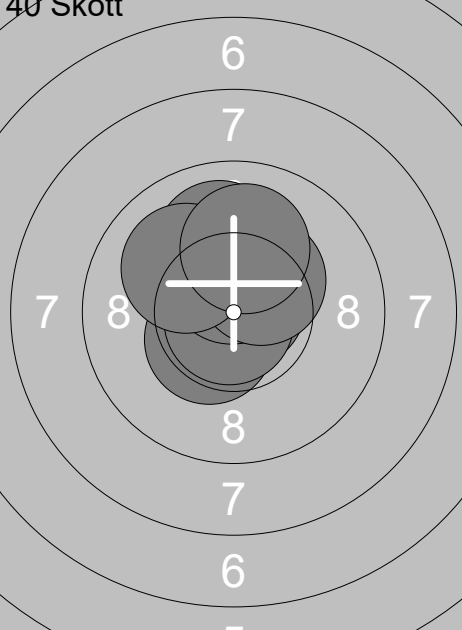
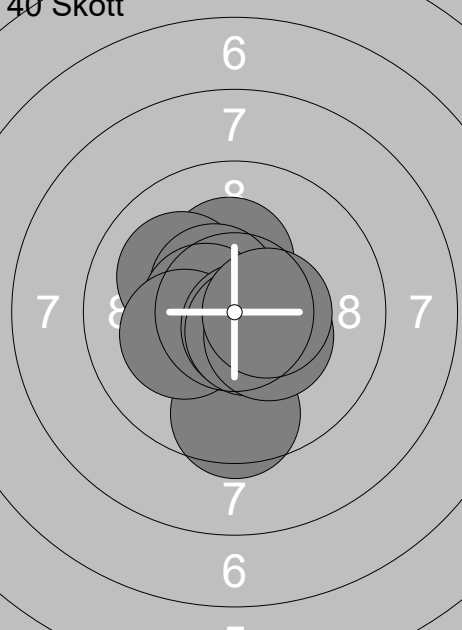
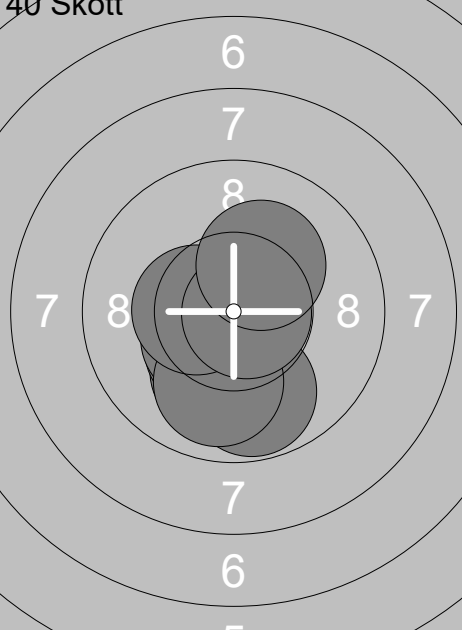
Skjuttag	Tavla	Agnes Ebbhagen		
1	26	Ramselefors	13	Vb
04.11.2018	Vindelnskyttet 2018	Ramselefors SKF		
Prov 	1: 9.6 ↙	Prov 	12: 10.3x ➤	
	2: 8.9 ↓		13: 10.2x ↓	
	3: 9.1 ↙		14: 10.3x ➤	
	4: 10.0 ↙		15: 10.1 ↙	
	5: 9.6 ↓		16: 10.3x ↙	
	6: 10.3x ↓		17: 10.5x ➤	
	7: 10.2x ↓		18: 10.7x ➤	
	8: 10.4x ↙			
	9: 10.5x ↑			
	10: 10.3x ↓			
	Serie 95		Serie 70	
	Total 0		Total 0	
40 Skott 	1: 10.5x ↗	40 Skott 	11: 10.0 ➔	
	2: 10.3x ➔		12: 10.7x ↗	
	3: 10.4x ↙		13: 10.7x ↗	
	4: 10.1 ↙		14: 10.2x ➤	
	5: 10.4x ↙		15: 10.3x ↑	
	6: 10.4x ➤		16: 10.8x ➤	
	7: 10.1 ↓		17: 10.7x ↙	
	8: 10.6x ↗		18: 10.1 ➔	
	9: 10.7x ➔		19: 10.4x ↑	
	10: 10.5x ↙		20: 10.5x ↘	
	Serie 100		Serie 100	
	Total 100		Total 200	
40 Skott 	21: 10.6x ↓	40 Skott 	31: 10.7x ↙	
	22: 9.8 ↓		32: 10.1 ↓	
	23: 10.1 ↓		33: 10.8x ↙	
	24: 10.5x ➤		34: 10.3x ↓	
	25: 10.5x ↗		35: 10.2x ↓	
	26: 10.6x ↑		36: 10.4x ↙	
	27: 10.3x ↓		37: 10.1 ↑	
	28: 10.6x ↗		38: 10.7x ↙	
	29: 10.5x ➔		39: 10.1 ↓	
	30: 10.6x ➤		40: 10.6x ➤	
	Serie 99		Serie 100	
	Total 299		Total 399	

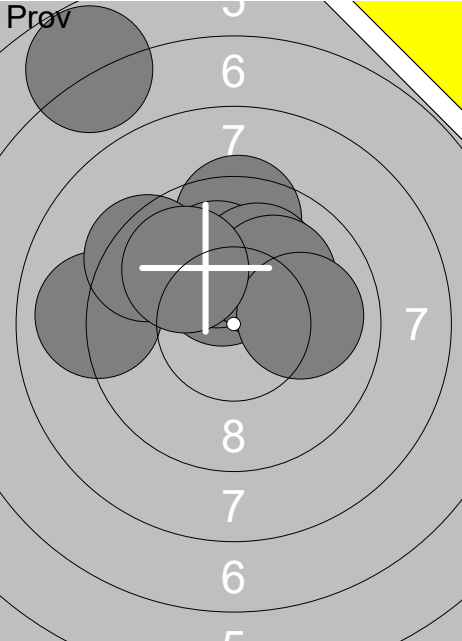
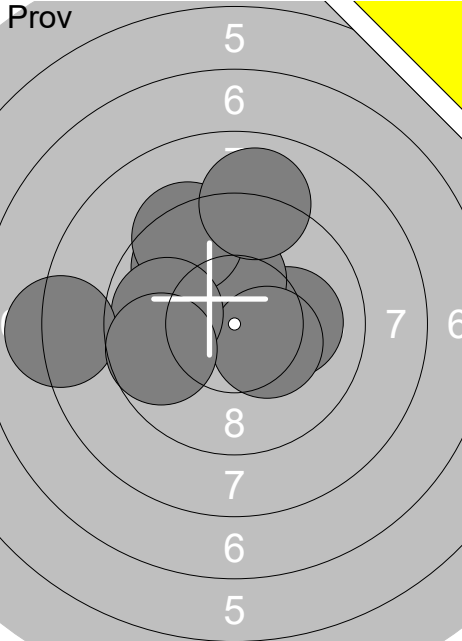
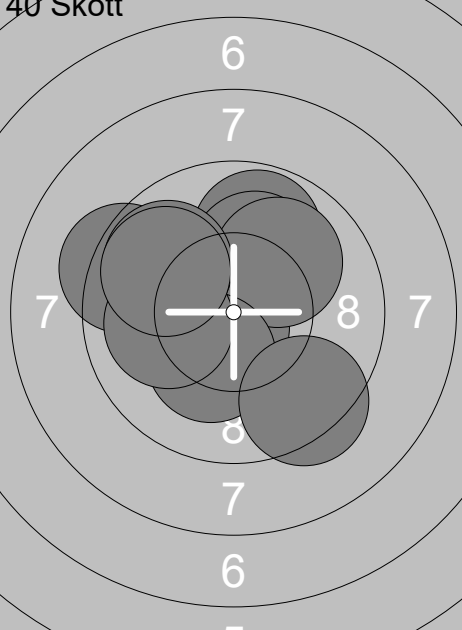
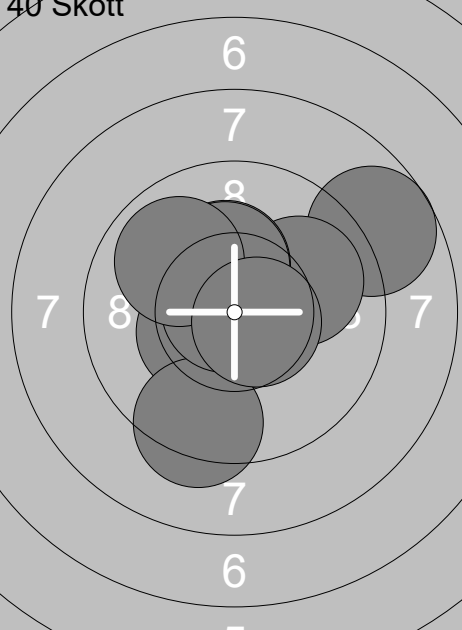
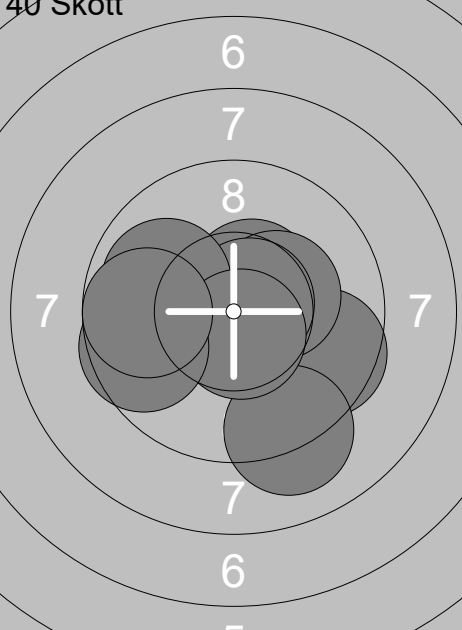
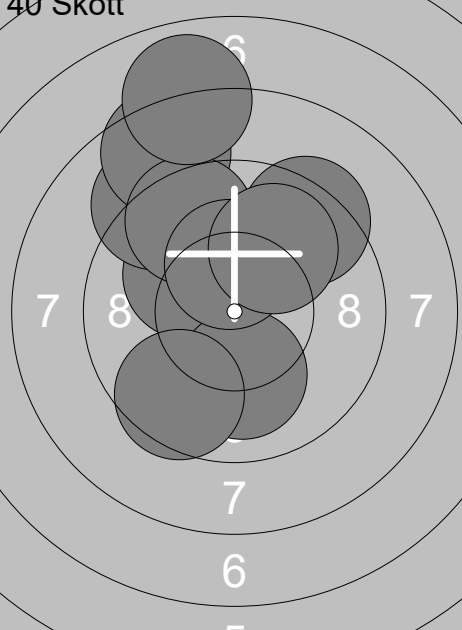
Skjutlag	Tavla	Jennifer Gustafsson		
1	27	Ramselefors	Ramselefors	13 Vb
04.11.2018	Vindelnskyttet 2018	Ramselefors SKF		
Prov 	1: 10.4x ← 2: 10.7x ↗ 3: 10.5x ↘ 4: 10.3x ↗ 5: 10.0 ↘ 6: 10.4x ← 7: 10.5x ↘ Serie 70 Total 0	40 Skott 	1: 10.2x ↗ 2: 10.4x ← 3: 9.9 ← 4: 10.2x ↙ 5: 10.4x ↙ 6: 10.7x ↙ 7: 10.8x ↙ 8: 10.5x ↗ 9: 10.7x ↘ 10: 10.0 ↘ Serie 99 Total 99	
40 Skott 	11: 10.4x ↙ 12: 10.3x ↗ 13: 10.8x ↗ 14: 10.5x ↘ 15: 10.0 ↗ 16: 10.8x ↙ 17: 10.5x ↗ 18: 10.4x ↗ 19: 10.0 ↘ 20: 10.1 ↗ Serie 100 Total 199	40 Skott 	21: 10.3x ↗ 22: 10.1 ↘ 23: 10.5x ↘ 24: 10.6x ← 25: 9.5 ↓ 26: 10.2x ← 27: 10.7x ↘ 28: 10.6x ↘ 29: 10.4x ↘ 30: 10.5x → Serie 99 Total 298	
40 Skott 	31: 10.9x ↘ 32: 9.8 ↓ 33: 10.1 ↓ 34: 10.3x ↙ 35: 10.4x ↙ 36: 10.9x ↙ 37: 10.0 ↓ 38: 10.4x ← 39: 10.8x → 40: 10.2x ↗ Serie 99 Total 397			

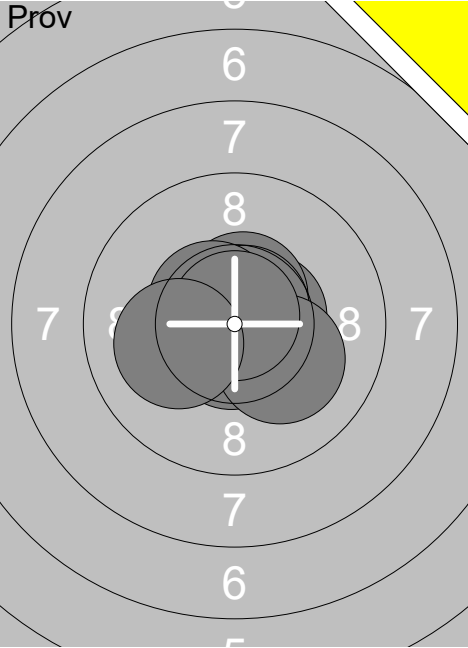
Skjutlag 1	Tavla 28	Robin Alfredsson			
Ramselefors		Umeå		7	Vb
04.11.2018		Vindelnskyttet 2018		Ramselefors SKF	
Prov 	1: 9.4 ↑ 2: 9.0 ← 3: 6.8 ↗ 4: 10.3x ↑ 5: 10.1 ↑ 6: 9.4 ↖ 7: 10.1 ↑ 8: 10.1 ↗ 9: 10.0 → 10: 9.9 ↖	Prov 	11: 10.7x ↑ 12: 9.8 ↖ 13: 10.1 → 14: 10.2x ↑ 15: 9.4 ↖ 16: 10.4x ↘ 17: 9.9 ← 18: 8.1 ← 19: 9.0 ↑ 20: 9.7 ←	Serie 92	Serie 93
	Total 0		Total 0		Total 0
40 Skott 	1: 9.8 ↑ 2: 9.3 ← 3: 10.1 ↑ 4: 10.7x ↘ 5: 10.0 ↗ 6: 10.2x ↘ 7: 10.0 ← 8: 9.8 ↖ 9: 9.8 ↖ 10: 9.4 ↘	40 Skott 	11: 8.7 ↗ 12: 10.7x ↘ 13: 10.4x ↙ 14: 10.0 → 15: 9.3 ↓ 16: 10.8x ↖ 17: 10.3x ↑ 18: 10.3x ↑ 19: 9.9 ↖ 20: 10.6x ↘	Serie 95	Serie 96
	Total 95		Total 191		Total 191
40 Skott 	21: 9.6 ↘ 22: 10.5x ↗ 23: 10.8x → 24: 10.3x → 25: 10.7x → 26: 9.9 ← 27: 9.1 ↓ 28: 10.6x ↘ 29: 9.6 ← 30: 9.7 ←	40 Skott 	31: 10.1 ↖ 32: 9.1 ↖ 33: 10.1 ↓ 34: 8.5 ↑ 35: 9.5 ↖ 36: 7.9 ↑ 37: 10.3x ↑ 38: 9.4 ↗ 39: 9.9 ↗ 40: 9.6 ↘	Serie 95	Serie 90
	Total 286		Total 376		Total 376

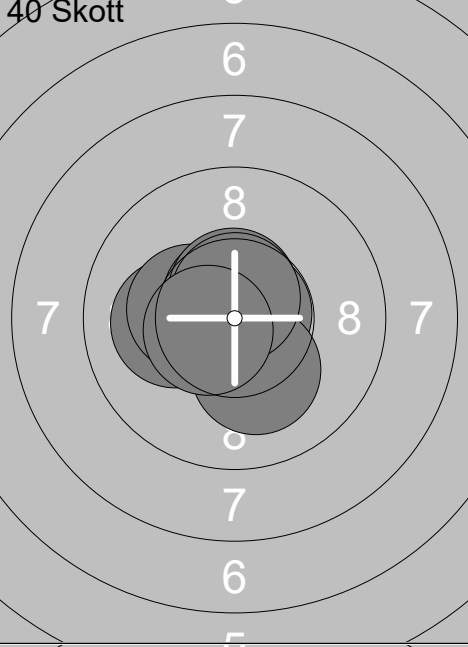
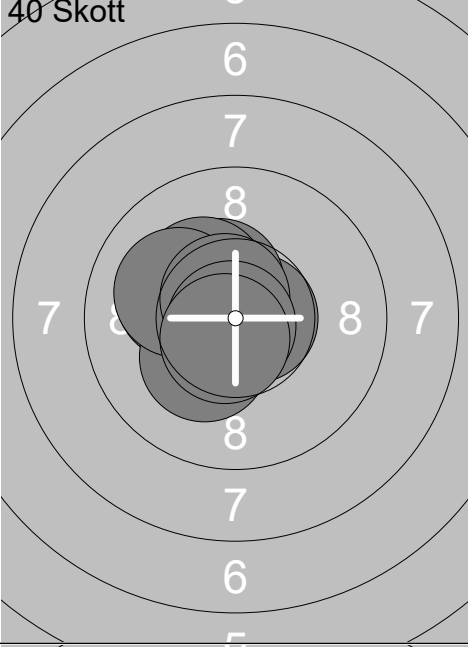
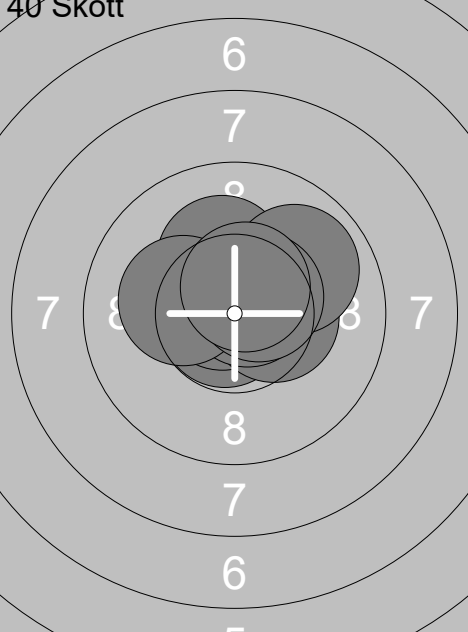
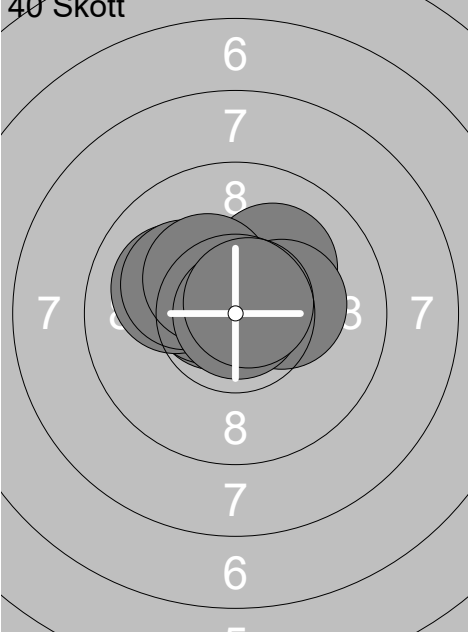
Skjutlag	Tavla	Rasmus Alfredsson			
1	29	Umeå	11	Vb	
04.11.2018	Vindelnskyttet 2018	Ramselefors SKF			
Prov		1: 10.6x → 2: 10.7x ↓ 3: 10.7x ↓ 4: 10.8x ↗ 5: 10.6x ↗ 6: 10.7x ↗ 7: 10.2x ↘ 8: 10.6x ↘ 9: 10.8x ↗ 10: 10.1 ←	Prov		11: 10.7x ↓ 12: 10.7x ←
	Serie 100		Serie 20		
	Total 0		Total 0		
40 Skott		1: 10.7x ← 2: 10.8x ↓ 3: 10.8x → 4: 10.1 ← 5: 10.2x ↓ 6: 10.3x ← 7: 10.7x ↗ 8: 10.6x ↗ 9: 10.7x ↗ 10: 10.5x ←	40 Skott		11: 10.1 ← 12: 10.7x ← 13: 10.7x → 14: 10.4x ↗ 15: 10.3x ↓ 16: 10.3x ↘ 17: 10.1 ← 18: 10.6x ↗ 19: 10.8x ↓ 20: 10.6x ↓
	Serie 100		Serie 100		
	Total 100		Total 200		
40 Skott		21: 10.8x ↘ 22: 10.7x ↘ 23: 10.4x ↘ 24: 10.2x ↗ 25: 10.4x → 26: 9.9 ↗ 27: 10.7x ↗ 28: 10.2x ← 29: 10.5x ↗ 30: 10.6x ↗	40 Skott		31: 10.7x → 32: 10.7x ← 33: 10.1 ↗ 34: 10.5x ← 35: 10.1 ← 36: 10.1 ← 37: 10.3x → 38: 10.3x ↘ 39: 10.9x → 40: 10.7x ↗
	Serie 99		Serie 100		
	Total 299		Total 399		

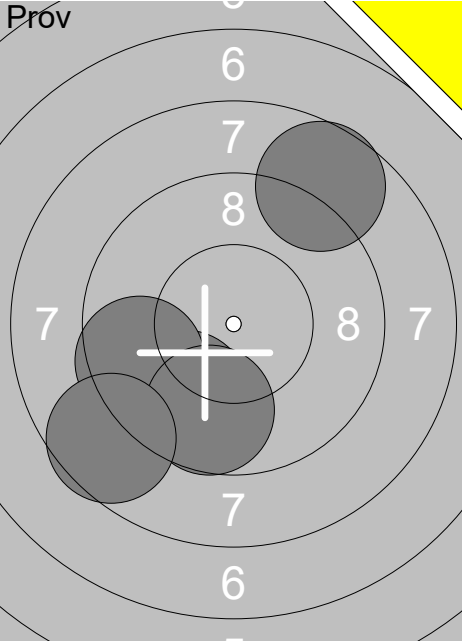
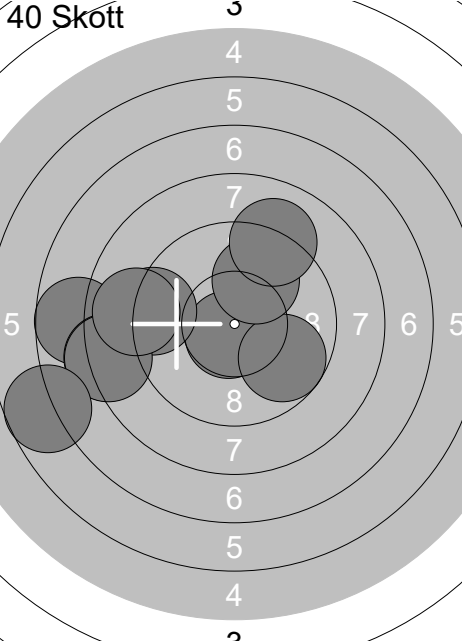
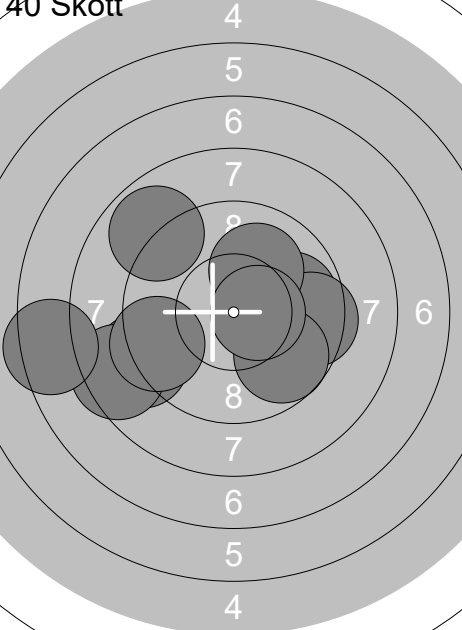
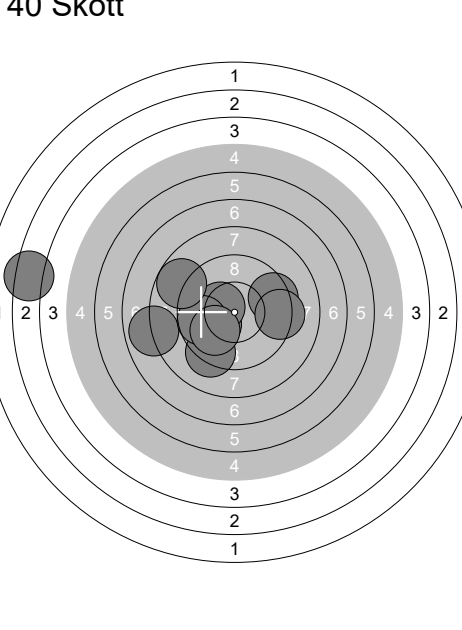
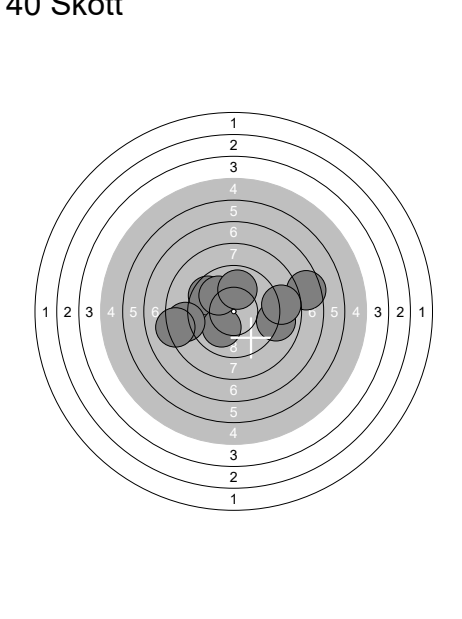
Skjutlag 1	Tavla 30	Atle Chen Brinkstam		
Ramselefors	Umeå	9	Vb	
04.11.2018	Vindelnskyttet 2018	Ramselefors SKF		
Prov		40 Skott 	1: 9.7 ↘ 2: 9.5 ← 3: 8.7 ↗ 4: 9.7 ↓ 5: 8.6 ↙	1: 10.7x ↘ 2: 9.7 ↘ 3: 7.7 ← 4: 9.2 ← 5: 8.2 ← 6: 8.3 ← 7: 8.9 ← 8: 9.9 ↗ 9: 9.1 ↗ 10: 6.7 ←
	Serie 43		Serie 83	
	Total 0		Total 83	
40 Skott		40 Skott 	11: 9.9 → 12: 9.0 ← 13: 8.9 ↗ 14: 9.5 → 15: 8.5 ← 16: 7.4 ← 17: 10.1 ↗ 18: 9.4 ← 19: 9.7 ↓ 20: 10.5x →	21: 9.5 → 22: 10.2x ↘ 23: 9.3 ↓ 24: 7.9 ← 25: 10.4x ↘ 26: 9.3 → 27: 3.4 ← 28: 9.7 ← 29: 10.0 ↓ 30: 8.7 ↘
	Serie 88		Serie 84	
	Total 171		Total 255	
40 Skott				
	Serie 78			
	Total 333			

Skjuttlag 2	Tavla 11	Elvina Bohman		
Ramselefors	Gideå	11	Vn	
04.11.2018	Vindelnskyttet 2018	Ramselefors SKF		
Pröv 	1: 10.6x ↓ 2: 10.5x ↑ 3: 10.3x ← 4: 10.4x ↓ 5: 10.6x ↑ 6: 10.4x → 7: 9.7 ↑ 8: 10.6x ↗ 9: 10.5x ← 10: 9.9 ↗ Serie 98 Total 0	Pröv 	11: 10.3x → 12: 10.4x ↑ 13: 9.3 ↑ 14: 10.9x ↑ 15: 10.6x ↗ 16: 9.2 ↗ 17: 9.2 → 18: 10.5x ↑ 19: 10.6x ↑ 20: 10.0 ↗ Serie 97 Total 0	
Pröv 	21: 10.5x ← 22: 9.7 → 23: 9.9 ↗ 24: 10.8x ↓ 25: 10.7x ↓ Serie 48 Total 0	40 Skott 	1: 10.3x ↗ 2: 10.5x ↓ 3: 10.2x ↓ 4: 10.4x ← 5: 10.8x ↓ 6: 10.3x ↑ 7: 10.5x ↓ 8: 10.0 ← 9: 10.2x → 10: 9.7 ↑ Serie 99 Total 99	
40 Skott 	11: 10.5x ↓ 12: 10.6x ↑ 13: 10.7x ↗ 14: 10.4x ↑ 15: 10.6x ↓ 16: 10.9x ↓ 17: 10.1 ↓ 18: 10.7x ← 19: 10.8x ↓ 20: 10.3x → Serie 100 Total 199	40 Skott 	21: 10.1 ← 22: 10.4x ↓ 23: 10.5x ↓ 24: 10.0 ↑ 25: 10.7x ← 26: 10.8x → 27: 9.9 ↗ 28: 9.6 ↑ 29: 10.7x ↓ 30: 10.7x ↓ Serie 98 Total 297	
40 Skott 	31: 10.3x ↓ 32: 10.4x ← 33: 10.5x ↗ 34: 9.9 ↗ 35: 10.4x ← 36: 10.6x ↗ 37: 10.4x ↓ 38: 10.8x ↓ 39: 10.4x ↗ 40: 10.7x ← Serie 99 Total 396			

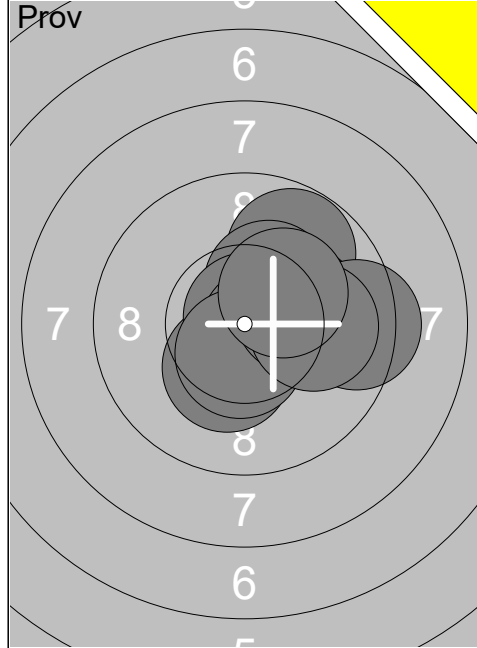

1: 9.8 ↗
2: 10.3x ↗
3: 10.3x ↓
4: 10.8x ↗
5: 10.7x →
6: 10.5x ↓
7: 10.2x →
8: 9.4 →
9: 10.0 →
10: 10.3x ↗
Serie 98
Total 0

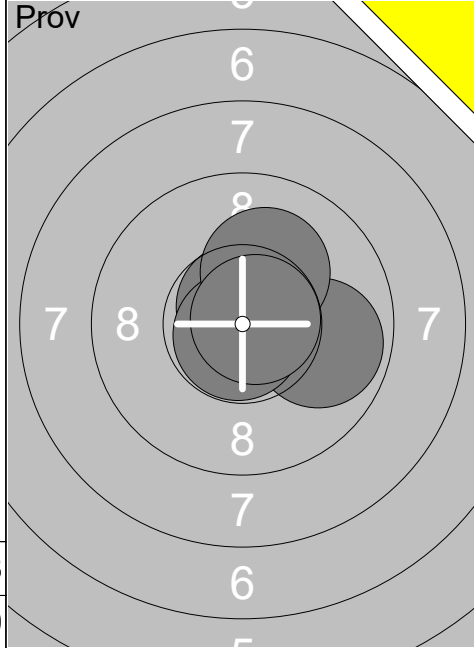

11: 10.7x ↑
12: 9.9 →
13: 10.8x ↓
14: 10.2x ↗
15: 10.8x →
Serie 49
Total 0

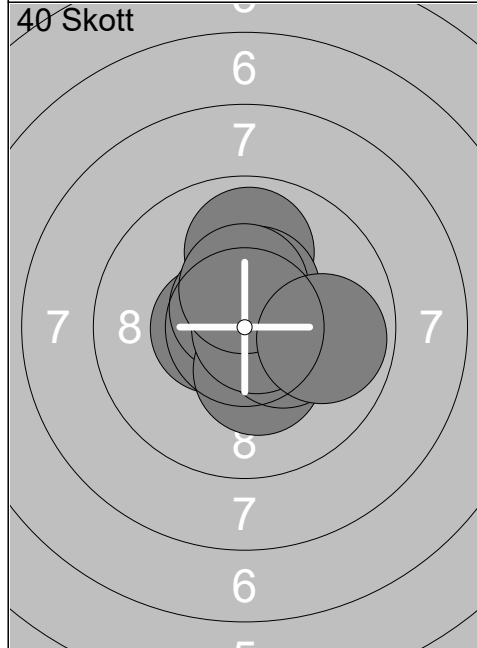

1: 9.9 ↑
2: 10.8x ↙
3: 10.5x ←
4: 10.6x ↖
5: 10.4x ↗
6: 10.3x ↓
7: 10.4x →
8: 10.8x →
9: 10.4x ↑
10: 9.9 →
Serie 98
Total 98

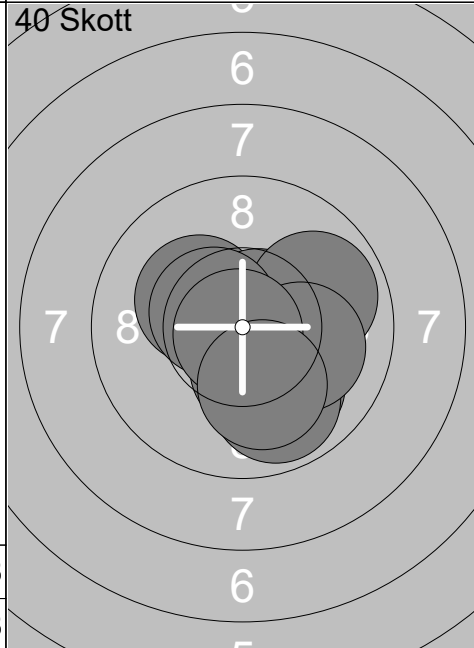

11: 10.2x ↖
12: 10.0 ↓
13: 9.9 ↓
14: 10.7x ↗
15: 9.9 →
16: 10.4x ↓
17: 10.5x ↖
18: 10.1 →
19: 10.8x ↓
20: 10.1 ↓
Serie 98
Total 196

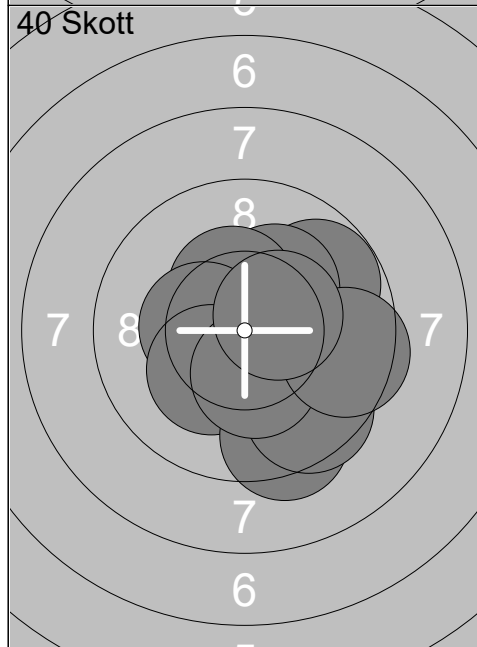

21: 9.8 ↗
22: 10.2x ↗
23: 10.4x ↗
24: 10.4x ←
25: 10.2x ↓
26: 9.4 ↓
27: 9.5 ↓
28: 10.3x ↓
29: 9.5 →
30: 10.4x ↗
Serie 96
Total 292

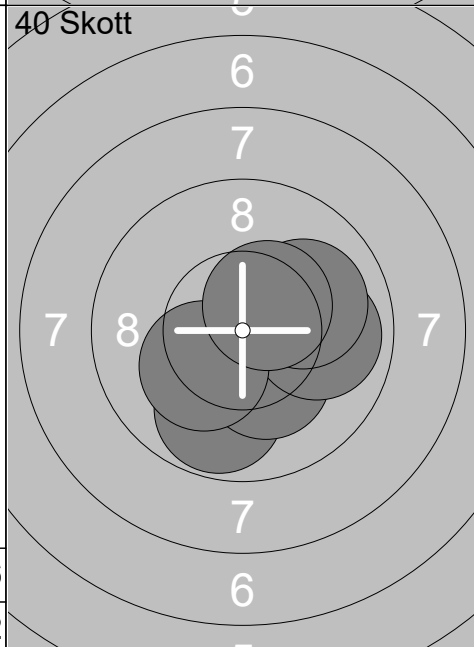

31: 10.6x →
32: 10.2x ↓
33: 10.2x →
34: 9.8 ↓
35: 10.6x →
36: 10.3x ↓
37: 9.9 →
38: 10.0 →
39: 10.2x ↙
40: 10.5x ↗
Serie 98
Total 390

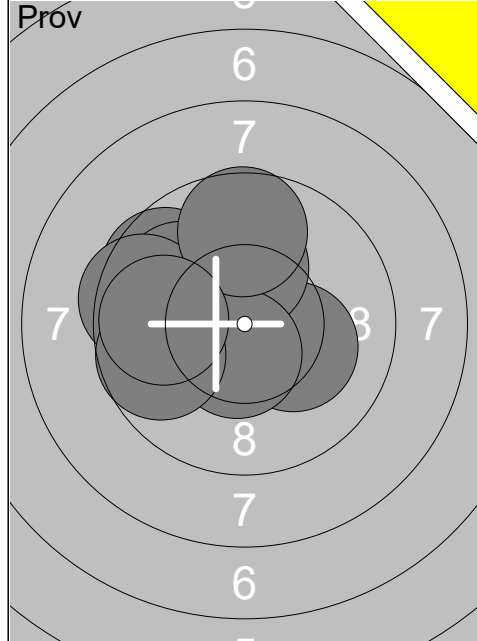

1: 10.2x	➤
2: 10.5x	↙
3: 9.6	↖
4: 10.2x	↑
5: 9.9	↖
6: 9.5	←
7: 10.5x	↓
8: 9.7	↑
9: 9.7	←
10: 9.8	←
Serie	94
Total	0

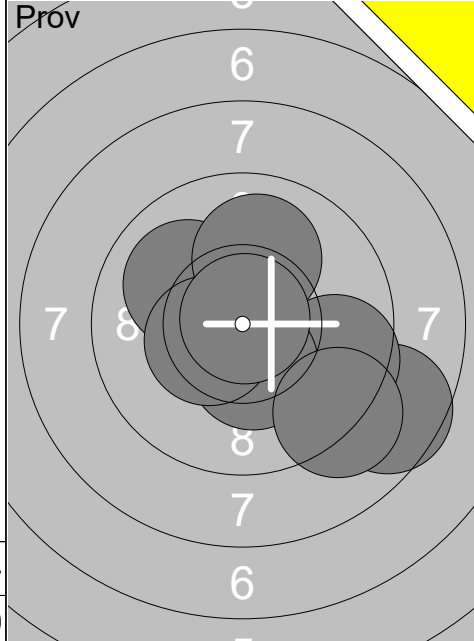

11: 8.6	↘
12: 10.0	↖
13: 9.6	➤
14: 10.0	↑
15: 10.4x	↓
16: 9.1	↘
17: 10.4x	↙
18: 10.9x	↑
Serie	76
Total	0

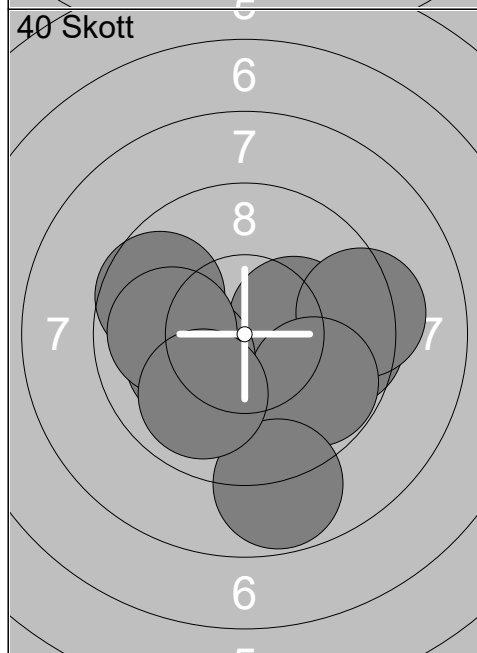

1: 10.2x	➤
2: 9.6	➤
3: 10.2x	➤
4: 9.3	➤
5: 9.8	↘
6: 10.1	←
7: 9.7	↖
8: 9.9	←
9: 8.8	↓
10: 9.9	↘
Serie	92
Total	92

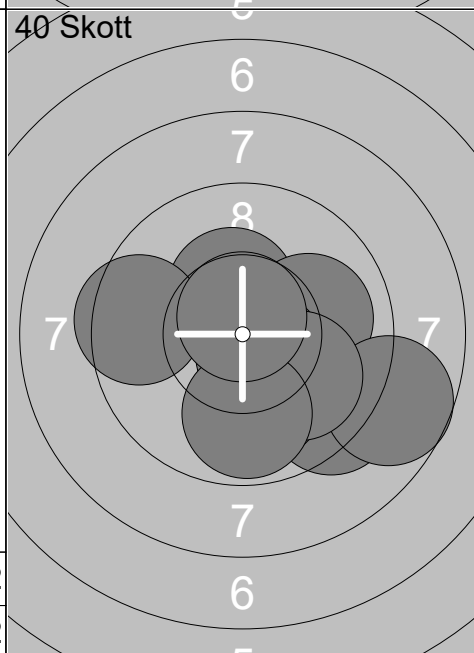

11: 10.4x	↑
12: 9.3	↘
13: 10.0	↓
14: 10.0	➤
15: 10.6x	↘
16: 8.7	➤
17: 10.0	↘
18: 9.8	↓
19: 9.5	←
20: 10.7x	↑
Serie	95
Total	187

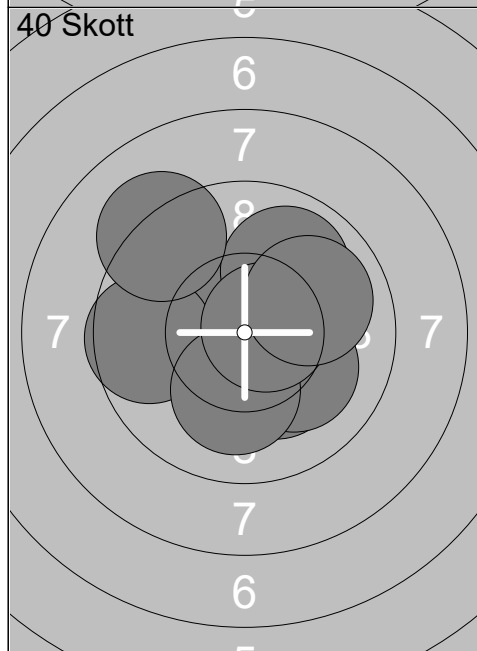

21: 10.6x	➤
22: 10.7x	↖
23: 9.6	←
24: 10.2x	↘
25: 10.1	↘
26: 10.1	↓
27: 9.9	↗
28: 10.6x	➤
29: 9.2	↖
30: 10.0	➤
Serie	97
Total	284

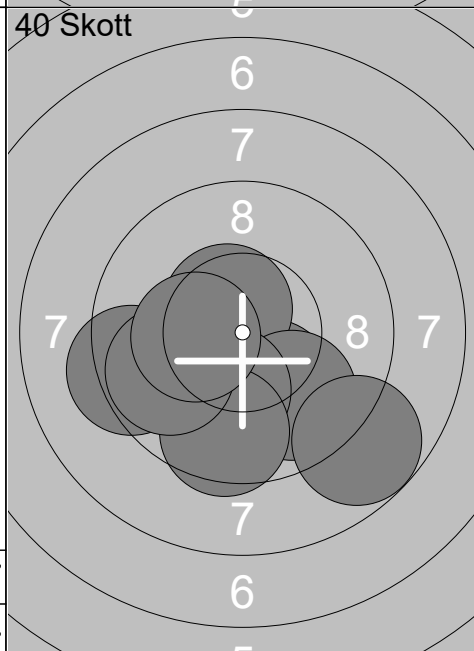

31: 10.1	↓
32: 9.3	←
33: 10.0	↓
34: 10.6x	↖
35: 9.8	↘
36: 10.1	↓
37: 9.6	↓
38: 9.8	←
39: 10.3x	←
40: 8.8	↘
Serie	94
Total	378

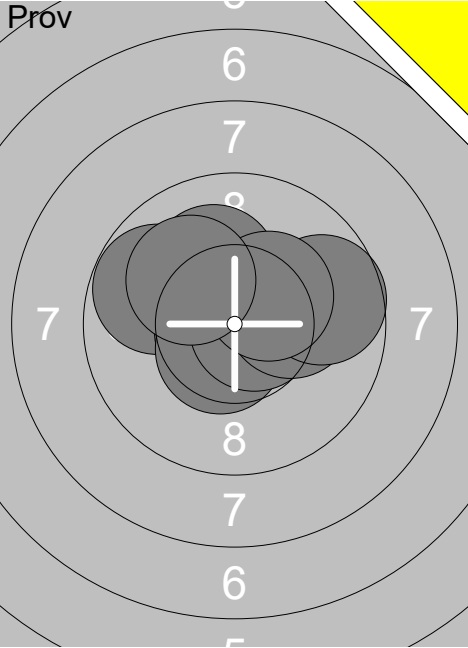
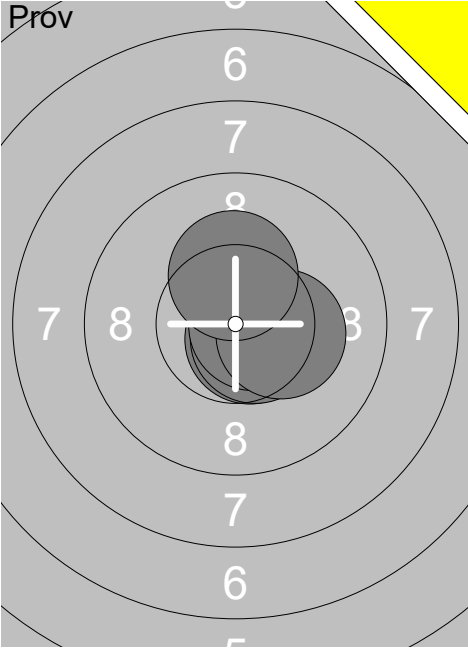
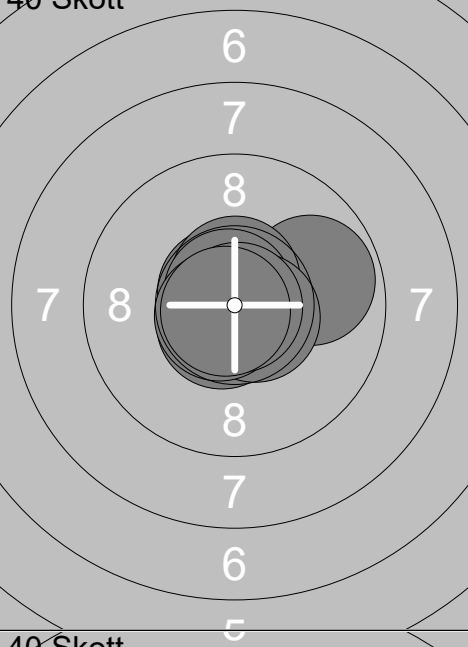
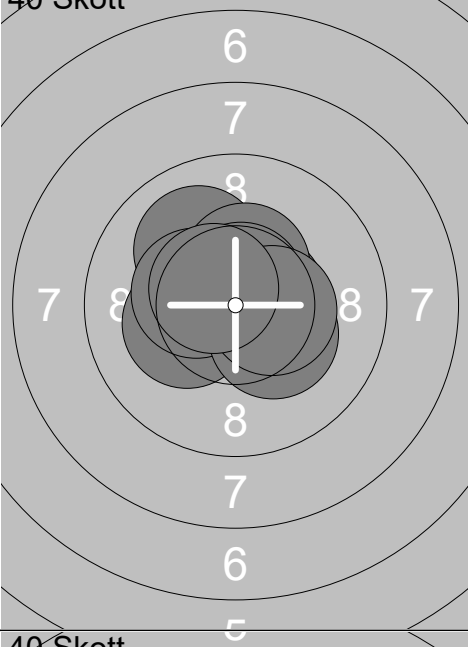
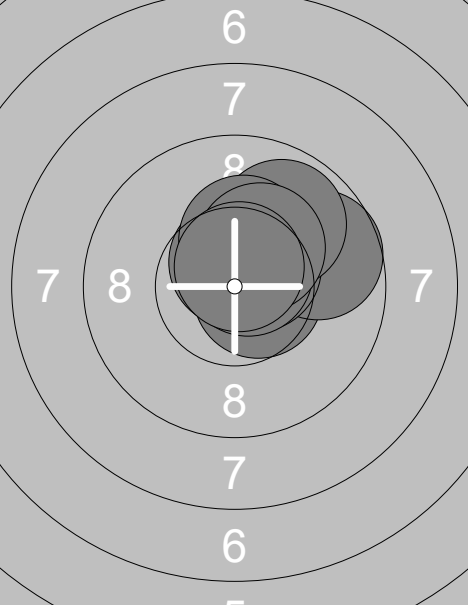
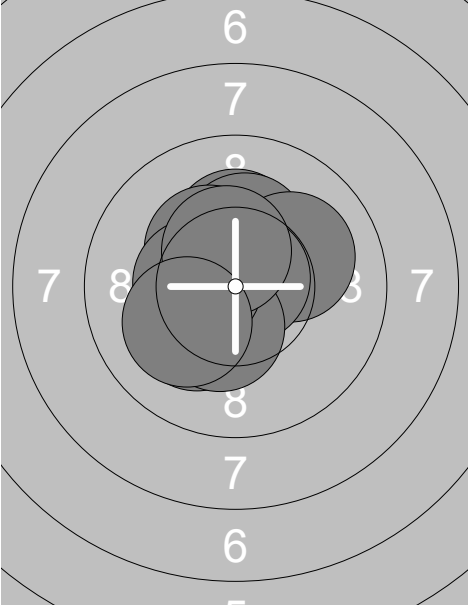
Skjutlag	Tavla	Johan Utsi Hæggrud		
2	14	Ramselefors	Gällivare	9 No
04.11.2018	Vindelnskyttet 2018	Ramselefors SKF		
Prov		1: 9.8 ↙	Prov	11: 10.7x ↘
		2: 10.7x ↙		12: 10.6x ↘
		3: 10.7x →		13: 10.7x →
		4: 10.5x ↘		14: 10.3x →
		5: 10.7x →		15: 10.3x ↑
		6: 10.2x →		
		7: 10.1 ↑		
		8: 9.7 →		
		9: 10.3x ↗		
		10: 10.1 ↙		
		Serie 98		Serie 50
		Total 0		Total 0
40 Skott		1: 10.7x ↘	40 Skott	11: 10.2x ↙
		2: 9.8 →		12: 10.6x →
		3: 10.7x ↙		13: 10.5x ↑
		4: 10.6x ↑		14: 10.0 ↙
		5: 10.6x ↘		15: 10.4x ↙
		6: 10.8x ↙		16: 10.4x ↑
		7: 10.6x →		17: 10.7x ↑
		8: 10.7x ↙		18: 10.3x ↘
		9: 10.9x ↘		19: 10.4x →
		10: 10.8x ↙		20: 10.6x ↙
		Serie 99		Serie 100
		Total 99		Total 199
40 Skott		21: 10.6x →	40 Skott	31: 10.2x ↑
		22: 10.6x ↑		32: 10.3x ↑
		23: 9.7 →		33: 10.1 ↗
		24: 10.5x ↗		34: 10.3x ↙
		25: 9.9 ↗		35: 10.2x ↘
		26: 10.5x ↗		36: 10.8x ↗
		27: 10.7x ↗		37: 10.4x ↘
		28: 10.3x ↑		38: 10.4x ↙
		29: 10.3x ↗		39: 10.4x ↑
		30: 10.7x ↑		40: 10.1 ↙
		Serie 98		Serie 100
		Total 297		Total 397

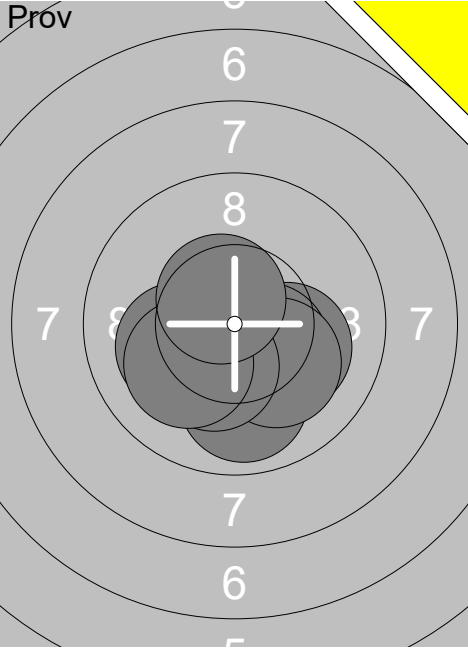
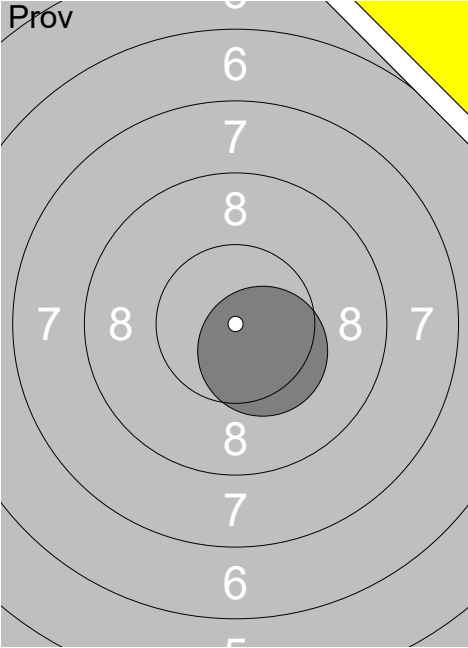
Skjutlag	Tavla	Caroline Rannebo	
2	15	Ramselefors	Gällivare
04.11.2018	Vindelnskyttet 2018	11	No
Prov		Ramselefors SKF	
	1: 10.2x ➤ 2: 9.9 ↓ 3: 10.4x ➤ 4: 10.7x ↓ 5: 10.2x ➤ 6: 10.2x ↙ 7: 10.3x ↓ 8: 10.1 ← 9: 10.1 ↙ 10: 10.6x ↗ Serie 99 Total 0		11: 10.4x ↘ Serie 10 Total 0
40 Skott	1: 10.3x ↙ 2: 10.7x ➤ 3: 10.7x ↓ 4: 10.2x ↗ 5: 10.3x ↙ 6: 10.0 ↓ 7: 10.7x ↑ 8: 10.7x ↗ 9: 10.4x ↗ 10: 10.6x ↙ Serie 100 Total 100	40 Skott	11: 10.7x ➤ 12: 10.9x ➤ 13: 10.4x ↓ 14: 10.5x ↑ 15: 10.2x ↙ 16: 10.6x ↙ 17: 10.3x ↓ 18: 10.5x ➤ 19: 10.6x ↙ 20: 10.3x ↙ Serie 100 Total 200
40 Skott	21: 9.9 ↙ 22: 10.5x ↙ 23: 10.3x ↓ 24: 10.6x ➤ 25: 10.5x ↗ 26: 10.8x ↙ 27: 10.4x ↓ 28: 10.6x ↙ 29: 10.8x ↗ 30: 10.8x ↗ Serie 99 Total 299	40 Skott	31: 10.2x ↓ 32: 10.6x ↙ 33: 10.6x ➤ 34: 10.4x ↓ 35: 10.5x ↙ 36: 10.3x ↓ 37: 10.8x ↙ 38: 10.8x ↓ 39: 10.8x ↑ 40: 10.8x ➤ Serie 100 Total 399

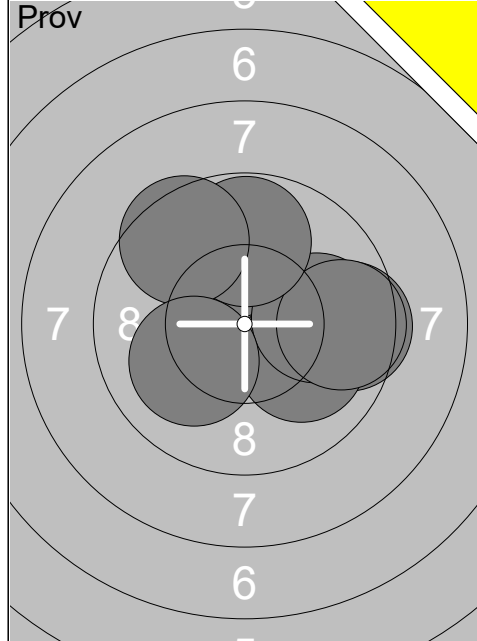

1:	9.9	→
2:	10.3x	↑
3:	9.5	→
4:	10.0	↘
5:	10.0	↑
6:	10.0	→
7:	9.6	→
8:	9.8	↑
9:	9.5	↖
10:	10.1	↙
Serie		95
Total		0

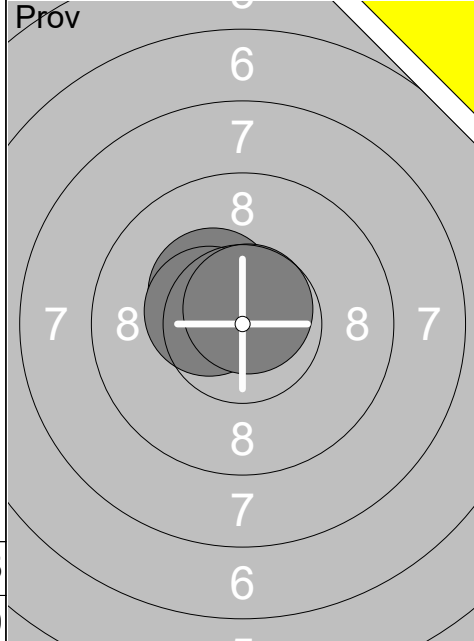

11:	10.4x	↖
12:	10.5x	↙
13:	10.7x	↗
Serie		30
Total		0

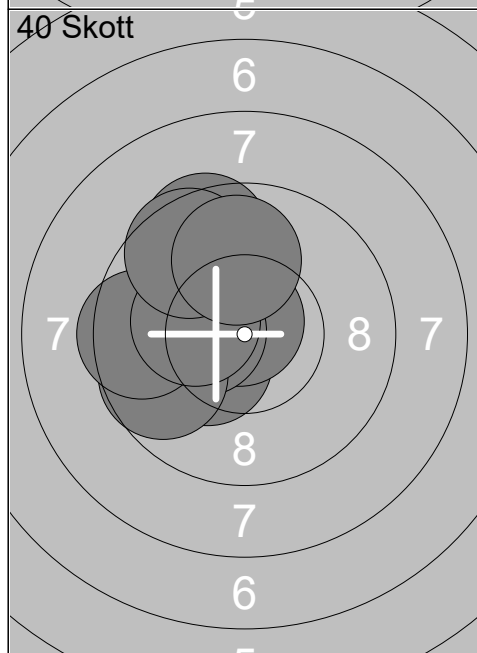

1:	10.3x	↙
2:	10.3x	↙
3:	10.8x	↗
4:	10.3x	↙
5:	9.7	↙
6:	9.5	↑
7:	9.5	←
8:	10.2x	↙
9:	9.6	↗
10:	9.9	↑
Serie		95
Total		95

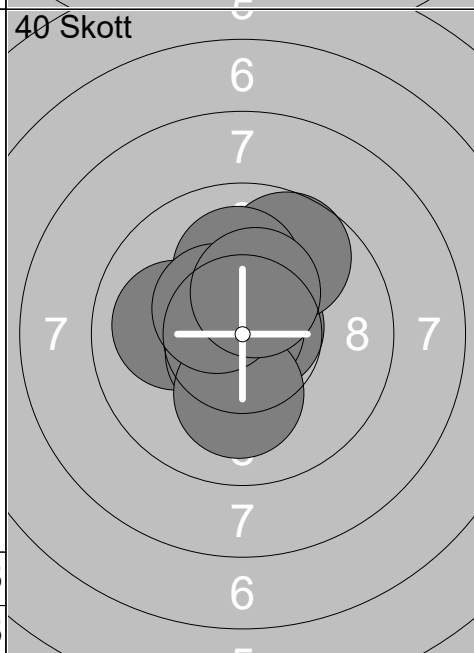

11:	10.0	←
12:	10.6x	↙
13:	10.7x	↗
14:	9.7	↗
15:	10.9x	↖
16:	10.5x	↖
17:	10.1	↑
18:	10.1	↓
19:	10.4x	↖
20:	10.3x	↗
Serie		99
Total		194

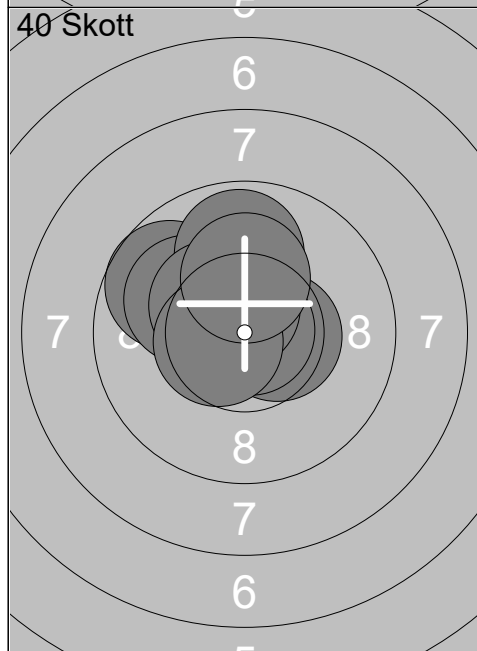

21:	9.7	↖
22:	10.3x	↖
23:	10.5x	→
24:	10.9x	↗
25:	10.0	↖
26:	9.9	↑
27:	10.6x	↑
28:	10.4x	↖
29:	10.6x	↙
30:	10.2x	↑
Serie		98
Total		292

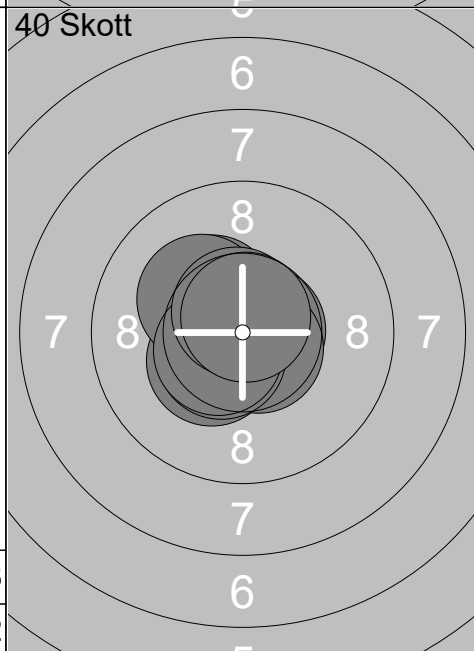

31:	10.3x	↖
32:	10.7x	→
33:	10.7x	↙
34:	10.6x	↘
35:	10.4x	↙
36:	10.5x	↙
37:	10.2x	↖
38:	10.5x	↙
39:	10.7x	↗
40:	10.7x	↗
Serie		100
Total		392

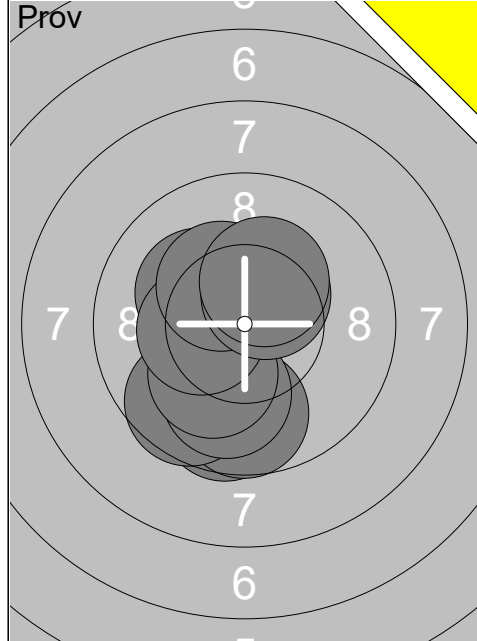

1:	9.6	↓
2:	9.7	↓
3:	9.6	↙
4:	10.0	↓
5:	10.1	↓
6:	10.2x	↖
7:	10.3x	←
8:	10.3x	↖
9:	10.4x	↗
10:	10.3x	↗
Serie		97
Total		0

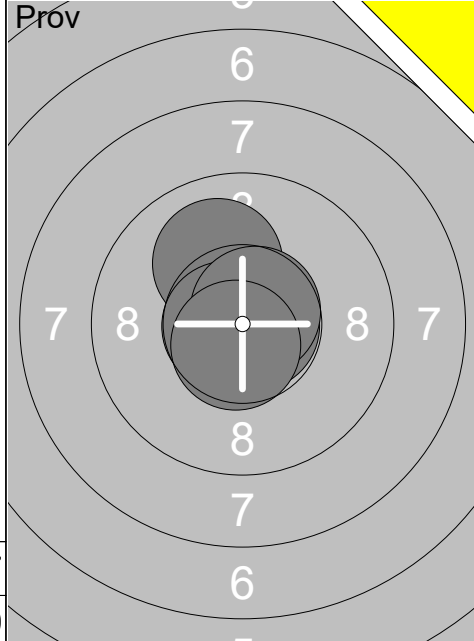

11:	10.8x	→
12:	10.0	↑
13:	10.7x	←
14:	10.7x	↗
15:	10.6x	↓
Serie		50
Total		0

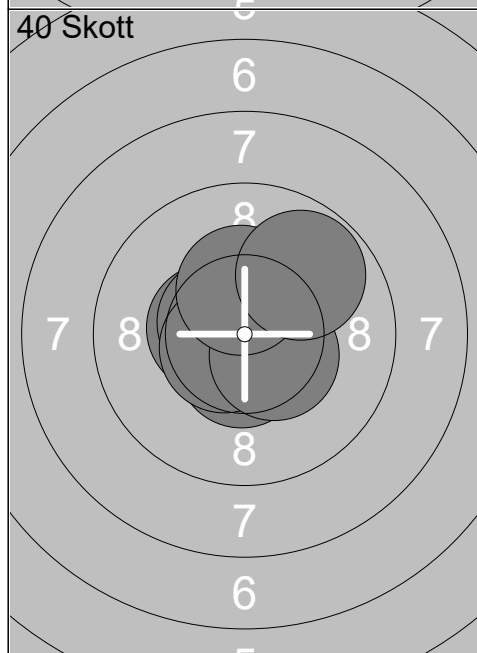

1:	10.5x	←
2:	10.6x	↖
3:	10.5x	↑
4:	10.7x	→
5:	10.5x	↓
6:	10.6x	↖
7:	10.4x	↗
8:	10.4x	↘
9:	10.3x	↑
10:	9.8	↗
Serie		99
Total		99

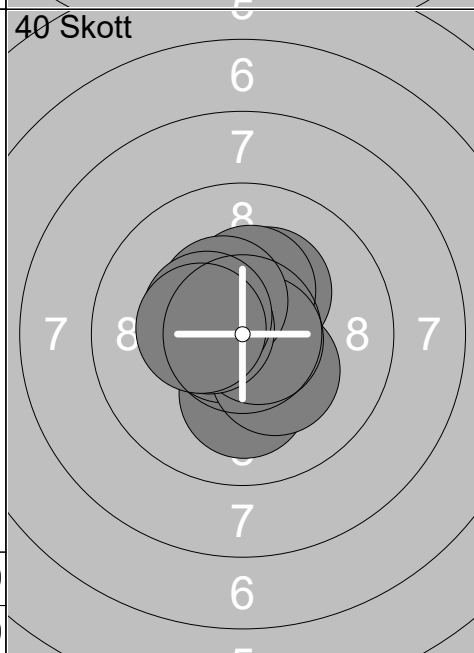

11:	10.1	↓
12:	10.7x	←
13:	10.3x	↗
14:	10.3x	↘
15:	10.3x	↑
16:	10.7x	→
17:	10.4x	↖
18:	10.5x	←
19:	10.4x	↖
20:	10.4x	←
Serie		100
Total		199

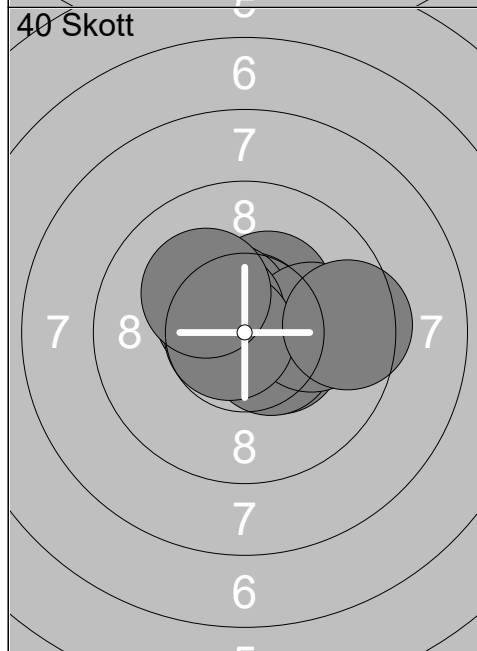

21:	10.3x	↗
22:	10.4x	→
23:	10.5x	↘
24:	10.7x	↑
25:	10.5x	↖
26:	10.0	→
27:	10.5x	↖
28:	10.7x	←
29:	10.2x	↖
30:	9.5	→
Serie		99
Total		298

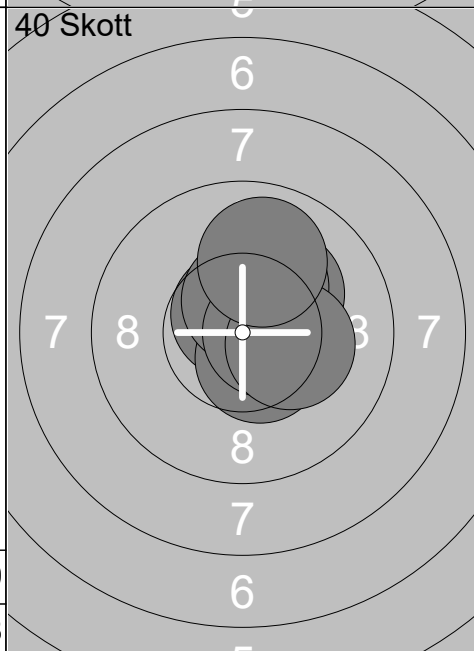

31:	10.5x	→
32:	10.8x	→
33:	10.2x	↗
34:	10.7x	↑
35:	10.5x	↘
36:	10.2x	↗
37:	10.5x	↑
38:	10.6x	→
39:	10.3x	→
40:	9.9	↑
Serie		99
Total		397

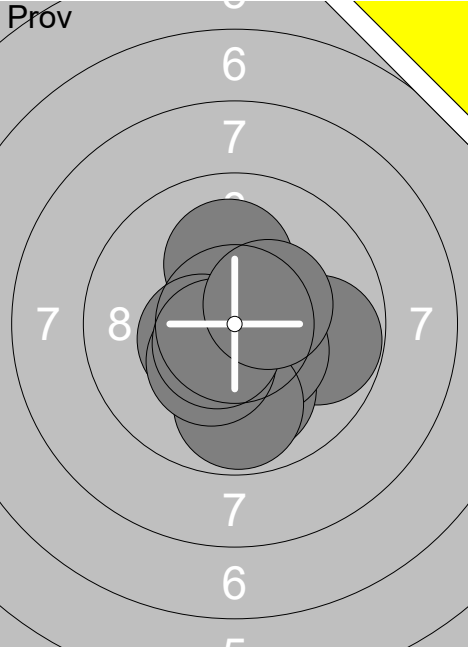
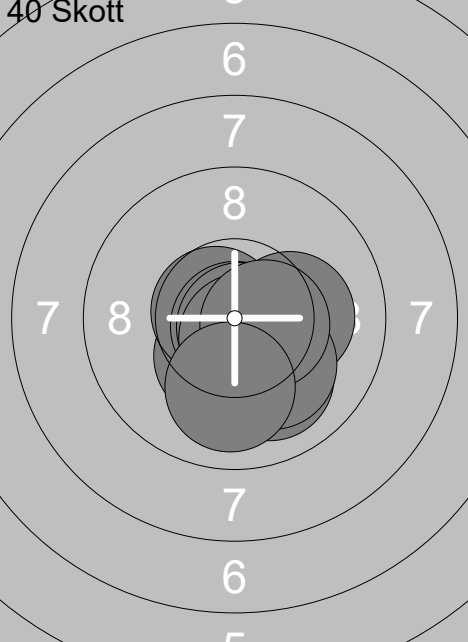
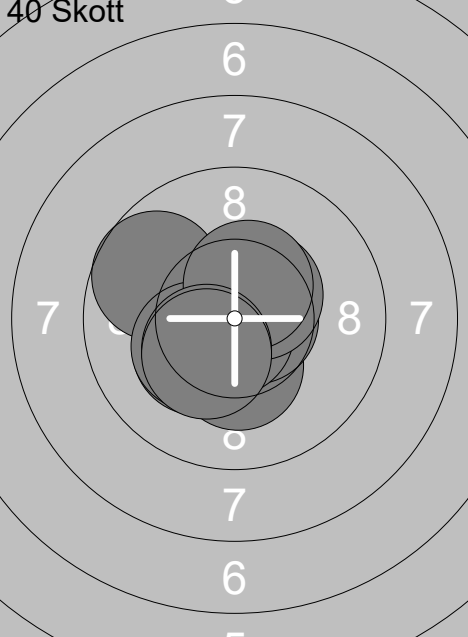
Skjutlag	Tavla	Sofia Öhman	
2	18	Ramselefors	Gällivare
04.11.2018		Vindelnskyttet 2018	Ramselefors SKF
13		No	
Prov		1: 9.8 → 2: 10.0 ↓ 3: 10.5x ↓ 4: 10.4x ↓ 5: 9.8 ↓ 6: 10.1 ↑ 7: 10.5x ← 8: 10.3x ↓ 9: 10.6x ↓ 10: 10.4x →	11: 10.2x → 12: 9.7 ↓ 13: 10.1 ↓ 14: 10.4x ↑
	Serie 98	Serie 39	
	Total 0	Total 0	
40 Skott		1: 10.0 ↓ 2: 10.2x → 3: 10.4x ↓ 4: 10.7x ← 5: 10.8x ↓ 6: 10.1 ↓ 7: 10.8x ↓ 8: 10.6x ↓ 9: 10.5x → 10: 10.0 ↓	11: 10.5x ↓ 12: 10.3x → 13: 10.2x ← 14: 10.7x ↑ 15: 10.2x ↑ 16: 10.7x ↓ 17: 10.6x ↓ 18: 10.4x ↓ 19: 10.2x ↓ 20: 10.6x →
	Serie 100	Serie 100	
	Total 100	Total 200	
40 Skott		21: 10.3x ↓ 22: 10.7x → 23: 10.8x ↓ 24: 10.3x ← 25: 9.7 ← 26: 10.5x → 27: 10.3x ← 28: 10.5x ↑ 29: 10.4x ↓ 30: 10.3x ↓	31: 10.1 ↓ 32: 10.0 ↑ 33: 10.5x ← 34: 10.4x ← 35: 10.5x ← 36: 10.5x → 37: 10.6x → 38: 10.4x ↑ 39: 10.8x → 40: 10.5x →
	Serie 99	Serie 100	
	Total 299	Total 399	

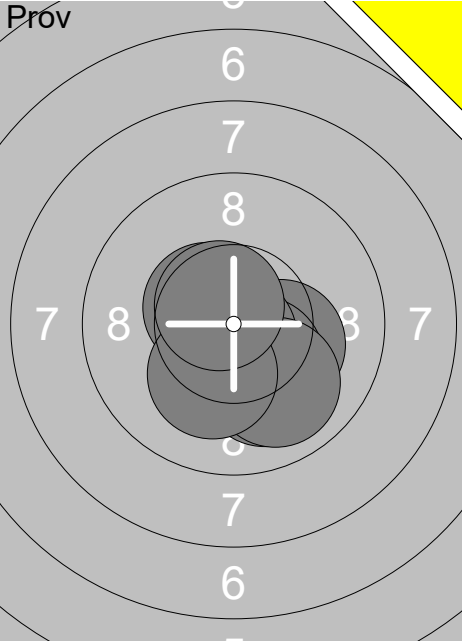
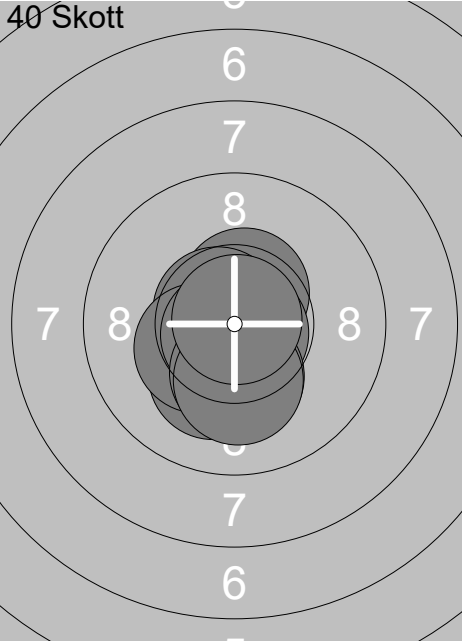
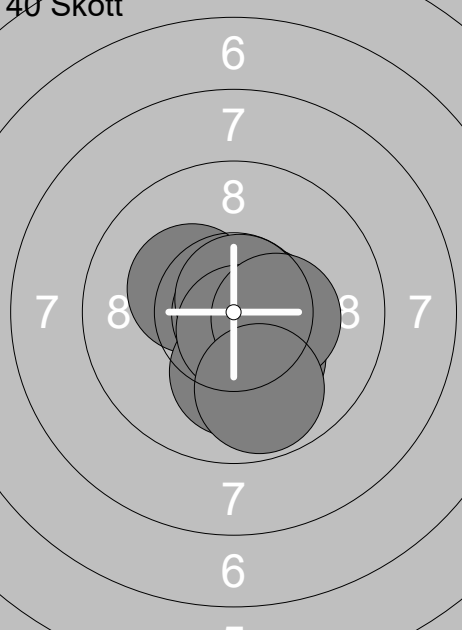
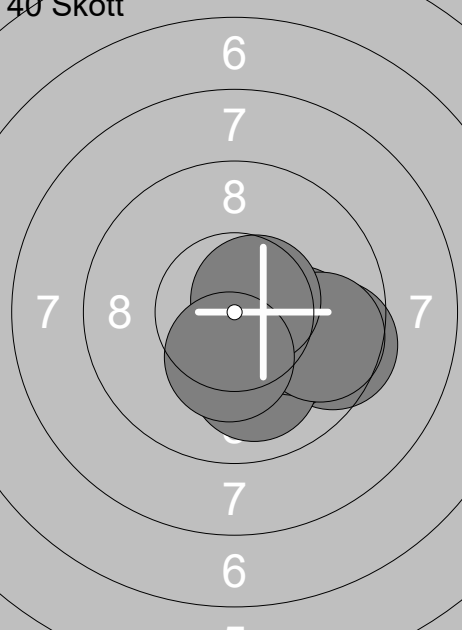
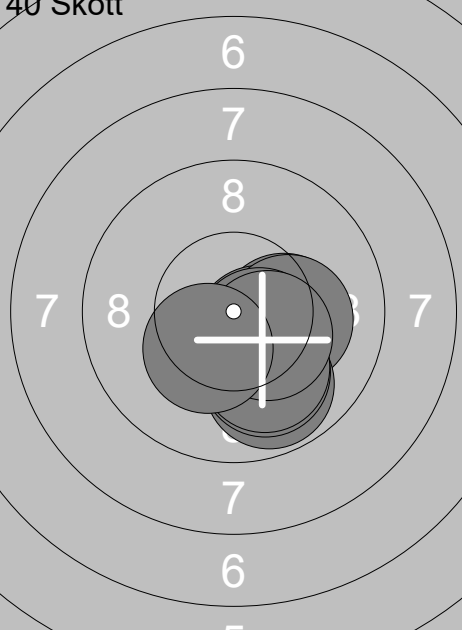
Skjutlag 2	Tavla 19	Vilda Stridsson	
Ramselefors	Gällivare	11	No
04.11.2018	Vindelnskyttet 2018	Ramselefors SKF	
Prov 	1: 10.5x ↗ 2: 10.2x ➤ 3: 10.3x ↘ 4: 10.8x ↓ 5: 10.0 ↓ 6: 10.0 ↓ 7: 10.2x ↘ 8: 10.6x ↗	40 Skott 	1: 10.5x ↗ 2: 10.2x ↓ 3: 10.8x ↘ 4: 10.7x ↗ 5: 10.2x ↓ 6: 10.3x ↙ 7: 10.8x ↙ 8: 10.3x ↓ 9: 10.2x ↓ 10: 10.9x ↗
	Serie 80		Serie 100
	Total 0		Total 100
40 Skott 	11: 10.3x ↗ 12: 10.1 ↓ 13: 10.9x ↘ 14: 10.4x ➤ 15: 10.2x ↘ 16: 10.6x ➔ 17: 10.8x ↗ 18: 10.7x ↘ 19: 10.4x ➔ 20: 9.8 ↓	40 Skott 	21: 10.4x ↘ 22: 10.4x ↘ 23: 9.5 ➔ 24: 10.2x ↘ 25: 10.6x ➔ 26: 10.0 ↓ 27: 10.1 ➔ 28: 9.7 ➔ 29: 10.6x ↗ 30: 10.3x ↓
	Serie 99		Serie 98
	Total 199		Total 297
40 Skott 	31: 10.3x ➔ 32: 10.5x ↘ 33: 10.2x ➔ 34: 9.8 ↓ 35: 10.5x ↘ 36: 10.2x ↘ 37: 10.0 ↓ 38: 10.1 ↓ 39: 10.4x ↘ 40: 10.3x ↘		
	Serie 99		
	Total 396		

Skjuttag	Tavla	Frank Nilsson		
2	20	Ramselefors	Rönnskär	11
04.11.2018	Vindelnskytten 2018	Ramselefors SKF		
Prov 	1: 8.9 → 2: 8.7 → 3: 10.1 ↘ 4: 10.0 ↘ 5: 10.1 → 6: 10.3x → 7: 10.5x ← 8: 9.6 ↗ 9: 10.1 ↗ 10: 10.5x ← Serie 95 Total 0	Prov 	11: 9.9 ↗ 12: 9.5 → 13: 10.4x ↖ 14: 10.5x ↓ 15: 9.8 ↓ Serie 47 Total 0	
40 Skott 	1: 9.3 ↗ 2: 10.3x ↗ 3: 10.2x → 4: 9.5 → 5: 10.6x ↗ 6: 9.2 → 7: 9.1 ↗ 8: 9.9 ← 9: 10.5x ↑ 10: 9.8 ↘ Serie 94 Total 94	40 Skott 	11: 8.9 → 12: 9.8 → 13: 10.5x ← 14: 10.4x ↘ 15: 9.9 → 16: 9.4 → 17: 9.7 ↗ 18: 10.0 → 19: 9.8 → 20: 10.2x ↗ Serie 93 Total 187	
40 Skott 	21: 10.4x ↑ 22: 10.6x ↗ 23: 10.2x ↗ 24: 10.5x → 25: 10.7x ↓ 26: 10.4x ↓ 27: 10.2x ← 28: 10.0 ← 29: 10.1 ↑ 30: 10.0 → Serie 100 Total 287	40 Skott 	31: 10.3x → 32: 9.9 → 33: 10.0 → 34: 10.3x ← 35: 10.4x → 36: 10.7x ← 37: 10.6x ↓ 38: 9.7 ↑ 39: 10.1 ↗ 40: 10.0 ← Serie 98 Total 385	

<p>Pröv</p>	<p>1: 8.5 ↓ 2: 9.0 ↓ 3: 9.8 ↓ 4: 10.2x ↓ 5: 10.5x ↑ 6: 9.6 ↓ 7: 10.6x ↓ 8: 10.5x ↓ 9: 10.4x ↓ 10: 9.5 ↓</p> <p>Serie 94 Total 0</p>	<p>Pröv</p>	<p>11: 10.4x ↓ 12: 10.4x ↘ 13: 9.3 ↓ 14: 9.7 ↓ 15: 10.7x → 16: 10.6x ↑ 17: 9.7 ↙ 18: 9.3 ↓ 19: 9.4 ↓ 20: 10.8x ↗</p> <p>Serie 95 Total 0</p>
--------------------	---	--------------------	--

<p>Pröv</p>	<p>21: 9.9 ↓ 22: 9.9 ↓ 23: 10.6x ↓ 24: 10.4x ← 25: 10.1 →</p> <p>Serie 48 Total 0</p>	<p>40 Skott</p>	<p>1: 9.7 ↙ 2: 10.7x ↑ 3: 10.1 ↓ 4: 10.3x → 5: 9.5 ↓ 6: 9.2 ↓ 7: 10.6x ↗ 8: 10.4x ↘ 9: 10.0 ↗ 10: 10.3x ↘</p> <p>Serie 97 Total 97</p>
--------------------	---	------------------------	--

<p>40 Skott</p>	<p>11: 10.4x ↑ 12: 10.1 ↓ 13: 10.4x ↑ 14: 10.3x ← 15: 9.8 ↓ 16: 10.7x ↑ 17: 10.5x ↓ 18: 10.6x → 19: 10.6x ↗ 20: 10.1 ↓</p> <p>Serie 99 Total 196</p>	<p>40 Skott</p>	<p>21: 10.4x ↙ 22: 10.7x → 23: 10.3x ↙ 24: 10.0 ↙ 25: 10.3x ↓ 26: 10.3x ↙ 27: 10.1 ↓ 28: 10.3x → 29: 9.6 ↓ 30: 10.0 →</p> <p>Serie 99 Total 295</p>
------------------------	--	------------------------	---

<p>40 Skott</p>	<p>31: 10.0 ↓ 32: 10.7x ↗ 33: 9.4 ← 34: 10.5x ↙ 35: 10.0 ↓ 36: 9.6 ↓ 37: 10.6x → 38: 10.6x ↑ 39: 10.8x ↑ 40: 10.3x ↗</p> <p>Serie 98 Total 393</p>		
------------------------	--	--	--

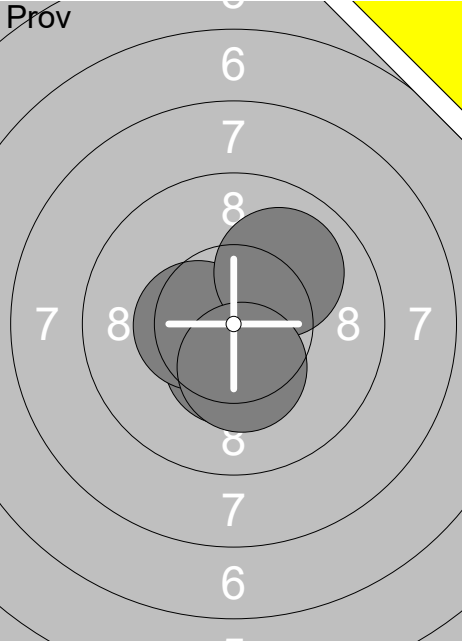
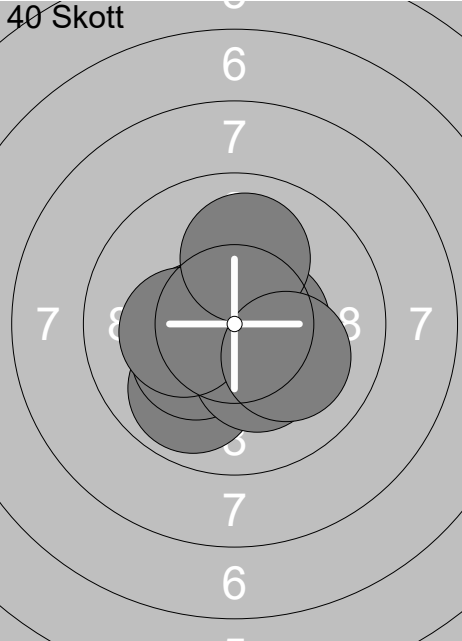
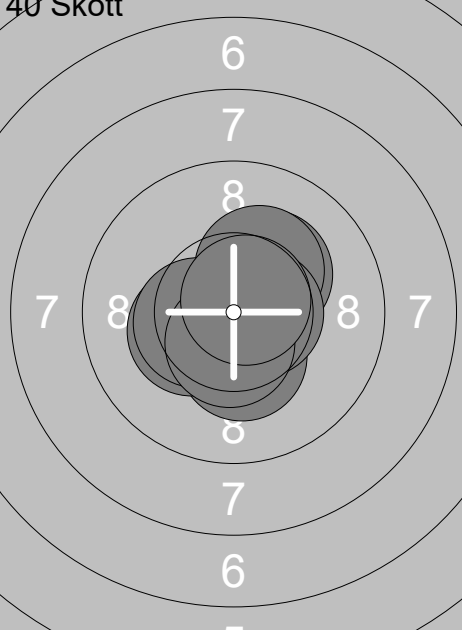
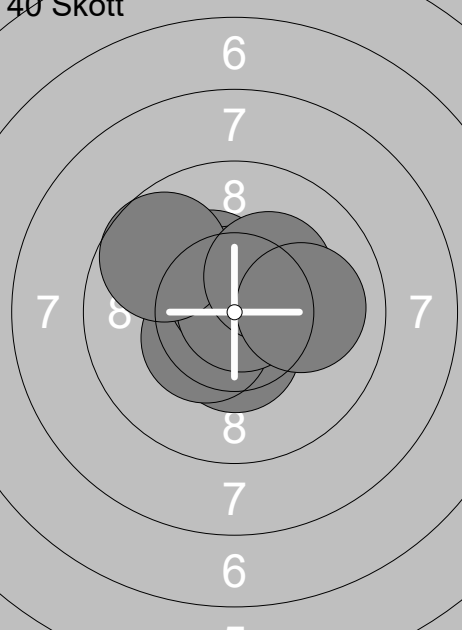
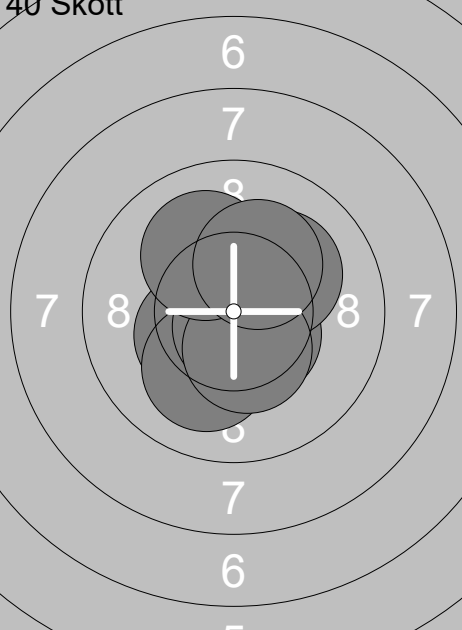
Skjutlag 2	Tavla 22	Rådgård Chen Brinkstam	
Ramselefors	Umeå	13	Vb
04.11.2018	Vindelnskytten 2018	Ramselefors SKF	
Prov 	1: 10.4x ↓ 2: 10.5x ← 3: 10.0 ↗ 4: 10.3x ↓ Serie 40 Total 0	40 Skott 	1: 10.4x ↙ 2: 10.9x ↗ 3: 9.9 ↓ 4: 10.5x ← 5: 10.5x → 6: 10.3x ↙ 7: 10.3x ↓ 8: 10.2x ← 9: 10.0 ↑ 10: 10.1 ↘ Serie 99 Total 99
40 Skott 	11: 10.6x ↓ 12: 10.2x ↗ 13: 10.3x ↓ 14: 10.3x ↗ 15: 10.8x ↙ 16: 10.6x → 17: 10.3x ← 18: 10.4x ← 19: 10.5x ↓ 20: 10.7x ↗ Serie 100 Total 199	40 Skott 	21: 10.7x ← 22: 10.5x → 23: 10.4x ↓ 24: 10.3x ↘ 25: 10.4x ↙ 26: 10.7x ↑ 27: 10.8x ↗ 28: 9.7 ↖ 29: 10.3x ↗ 30: 10.0 → Serie 99 Total 298
40 Skott 	31: 10.5x ↘ 32: 10.6x ↓ 33: 10.8x ↓ 34: 10.2x ↗ 35: 10.4x ↙ 36: 10.1 ↓ 37: 10.7x ↓ 38: 10.4x ↓ 39: 10.1 ↗ 40: 10.2x ↗ Serie 100 Total 398		

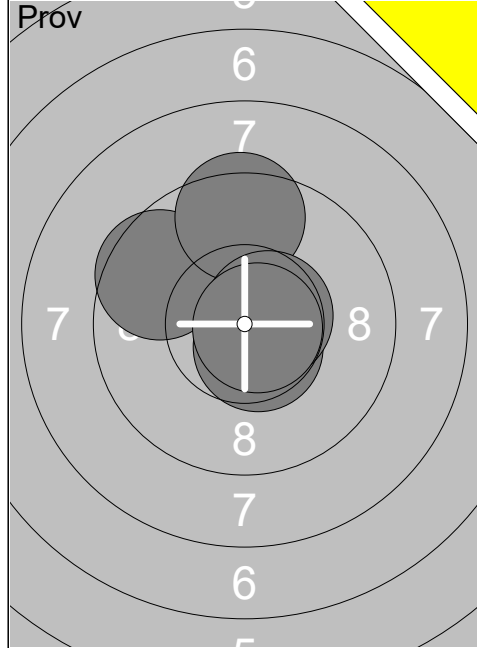

1: 9.6 ↖
2: 10.6x ↘
3: 9.5 ↑
4: 10.6x →
5: 10.8x →
Serie 48
Total 0

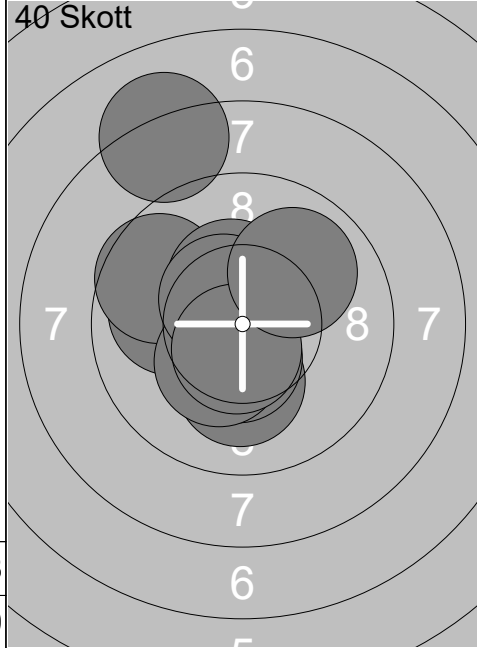

1: 10.1 ↓
2: 10.0 ←
3: 9.6 ↖
4: 10.4x ↑
5: 10.5x ↓
6: 10.3x ↘
7: 8.1 ↑
8: 10.5x ↖
9: 10.6x ↓
10: 10.0 ↗
Serie 97
Total 97

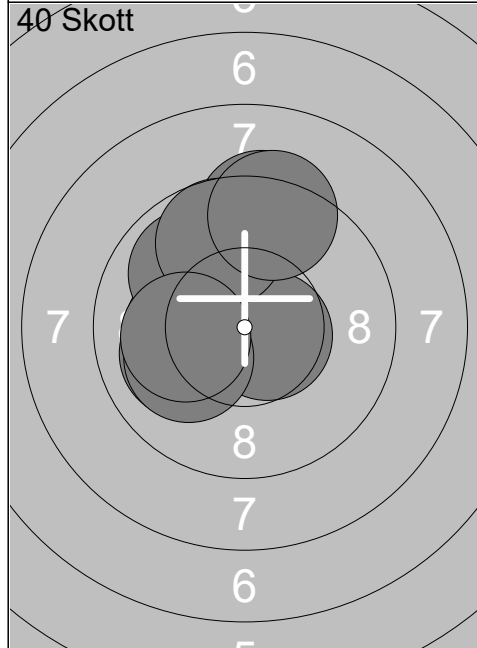

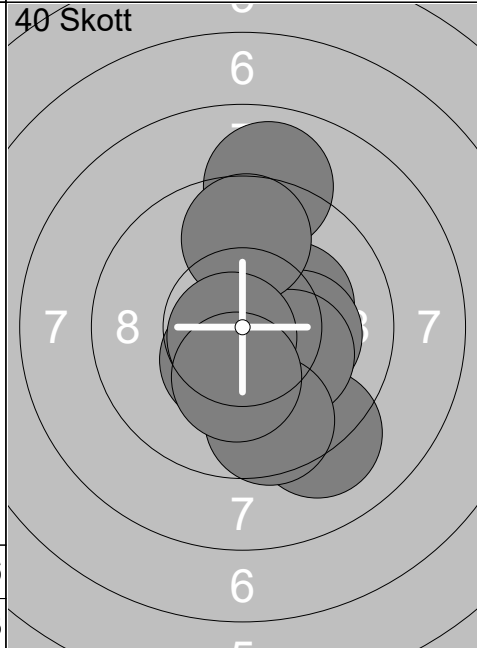

11: 10.2x ←
12: 10.1 ↗
13: 9.9 ↖
14: 10.0 ←
15: 9.4 ↑
16: 10.6x →
17: 9.7 ↑
18: 10.1 ←
19: 10.1 ←
20: 9.3 ↑
Serie 96
Total 193

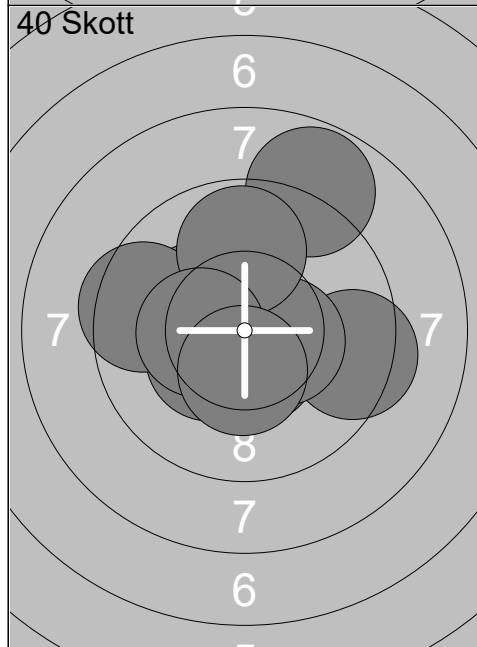

21: 9.1 ↘
22: 10.4x ↘
23: 10.2x →
24: 10.2x →
25: 10.2x →
26: 9.0 ↑
27: 9.6 ↓
28: 9.7 ↑
29: 10.8x ↙
30: 10.2x ↓
Serie 96
Total 289

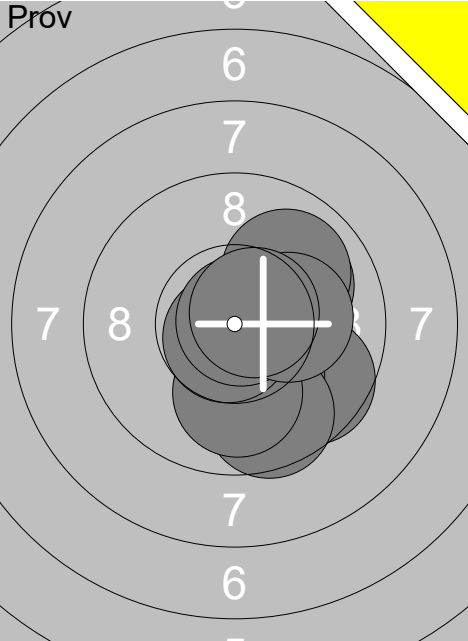

31: 10.5x ↓
32: 10.4x ↙
33: 9.4 →
34: 8.8 ↑
35: 10.4x →
36: 10.3x ↖
37: 9.5 ←
38: 9.8 ↑
39: 10.3x ←
40: 10.4x ↓
Serie 95
Total 384

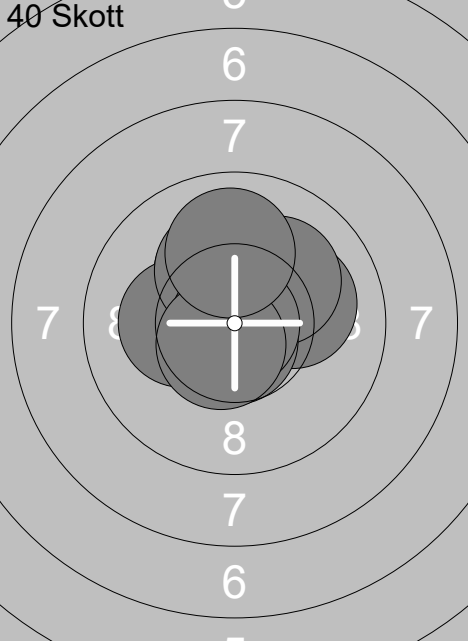
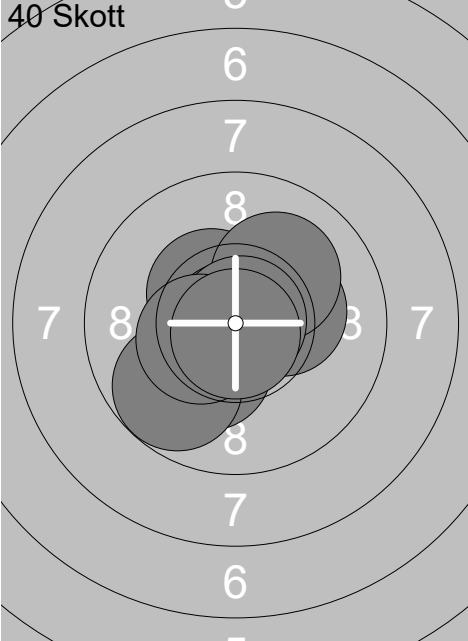
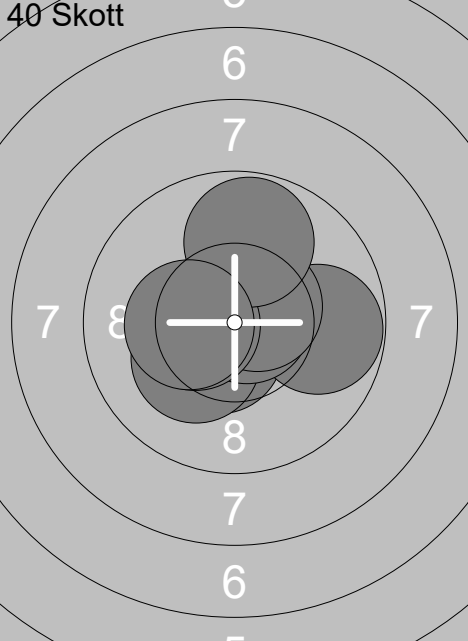
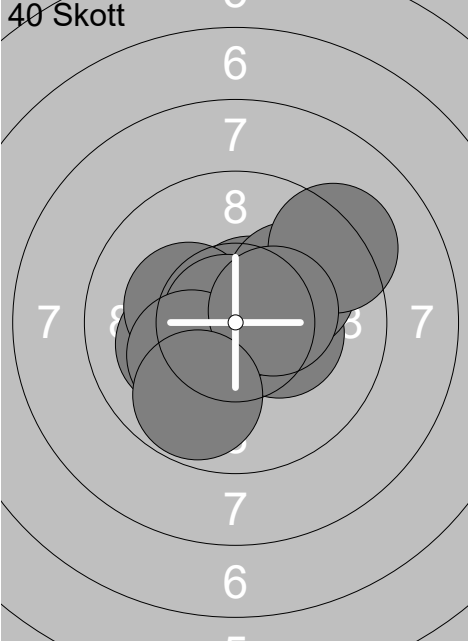
Skjutlag	Tavla	Mattias Lind	
2	24	Ramselefors	Skoga-Ekshärad
04.11.2018	Vindelnskyttet 2018	Ramselefors SKF	Sitt Vä
Prov		Prov	
	1: 9.6 ↘ 2: 10.2x ↘ 3: 9.6 ↘ 4: 10.0 ↓ 5: 10.7x ↘ 6: 10.0 ↗ 7: 10.0 ↗ 8: 10.9x ↗ 9: 10.2x → 10: 10.6x ↗ Serie 98 Total 0		11: 10.2x ↑ 12: 10.0 ↑ 13: 10.6x ↖ 14: 10.2x ↗ 15: 10.8x ↘ Serie 50 Total 0
40 Skott		40 Skott	
	1: 10.1 → 2: 10.1 ↗ 3: 10.5x ↖ 4: 10.2x ↖ 5: 10.2x ← 6: 10.2x ↖ 7: 10.7x ↓ 8: 10.9x ↓ 9: 10.6x ↘ 10: 10.0 ↑ Serie 100 Total 100		11: 10.3x → 12: 10.8x ↘ 13: 10.2x ↘ 14: 10.4x ↖ 15: 10.9x ↘ 16: 9.8 ↘ 17: 10.1 ↗ 18: 10.9x → 19: 10.4x ← 20: 10.8x ↓ Serie 99 Total 199
40 Skott		40 Skott	
	21: 10.5x ↘ 22: 10.2x ↘ 23: 9.8 → 24: 10.6x ↖ 25: 10.8x → 26: 10.7x ↖ 27: 10.6x ↗ 28: 10.4x ← 29: 9.8 ↑ 30: 10.3x ← Serie 98 Total 297		31: 10.6x ↗ 32: 10.3x → 33: 10.0 ↗ 34: 10.1 ← 35: 10.3x ← 36: 10.8x ← 37: 10.2x ↘ 38: 9.2 ↗ 39: 10.4x → 40: 9.8 ↓ Serie 98 Total 395

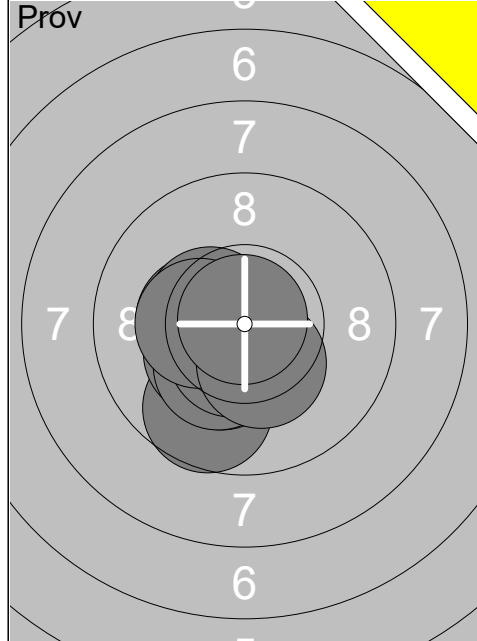

1: 9.7	↘
2: 10.3x	↙
3: 10.3x	↘
4: 10.3x	↘
5: 10.3x	←
6: 10.5x	↘
7: 10.5x	←
8: 10.3x	←
9: 10.4x	↘
10: 10.9x	↗
Serie	99
Total	0

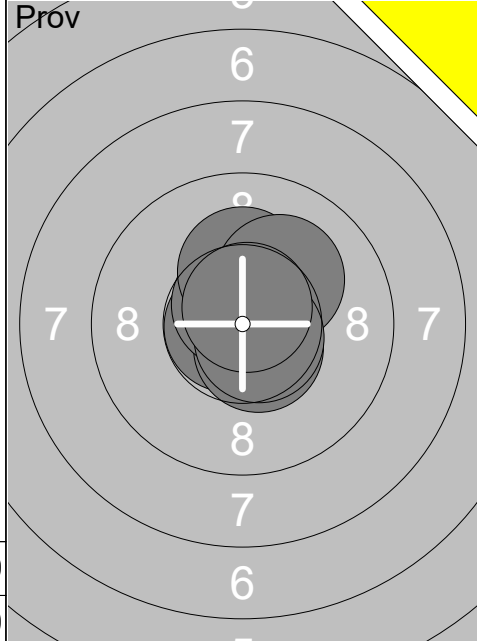

11: 10.8x	←
12: 10.6x	↘
13: 10.7x	↗
14: 10.2x	↑
15: 10.1	↗
16: 10.6x	↘
17: 10.7x	↗
Serie	70
Total	0

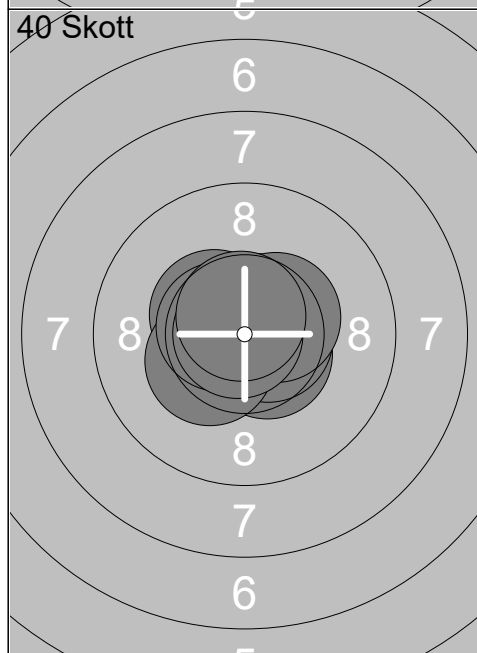

1: 10.6x	→
2: 10.5x	↘
3: 10.6x	→
4: 10.4x	↖
5: 10.3x	↙
6: 10.7x	↗
7: 10.5x	↗
8: 10.6x	←
9: 10.9x	←
10: 10.7x	↑
Serie	100
Total	100

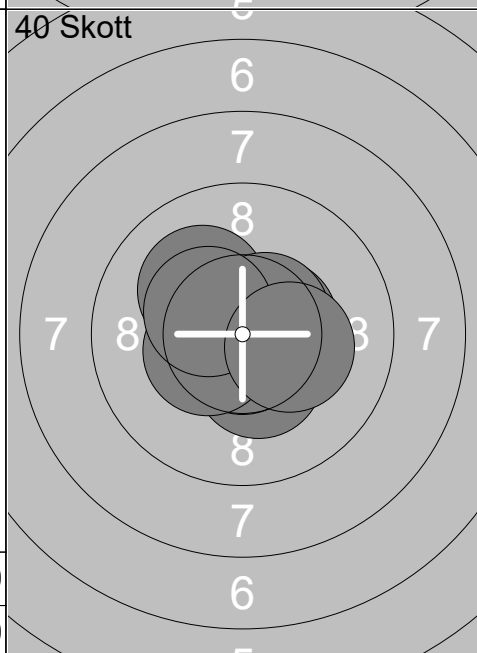

11: 10.1	↖
12: 10.6x	→
13: 10.9x	←
14: 10.4x	↘
15: 10.5x	→
16: 10.7x	↓
17: 10.6x	↗
18: 10.4x	←
19: 10.4x	↖
20: 10.3x	→
Serie	100
Total	200

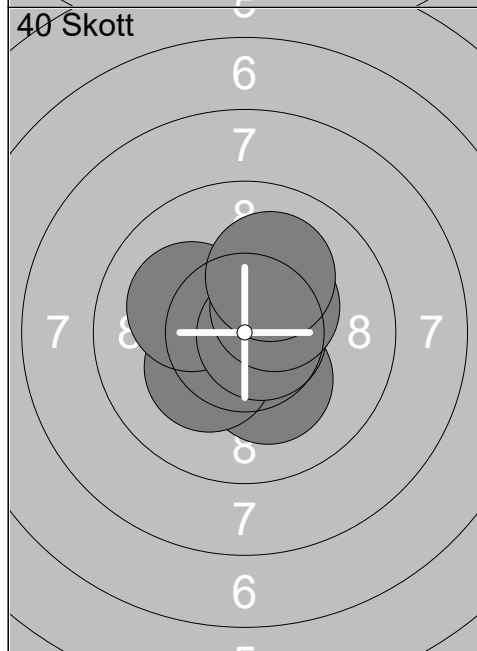

21: 10.6x	↗
22: 10.8x	↗
23: 10.9x	↘
24: 10.2x	↘
25: 10.6x	←
26: 10.3x	↙
27: 10.1	←
28: 10.7x	→
29: 10.4x	↗
30: 10.1	↗
Serie	100
Total	300

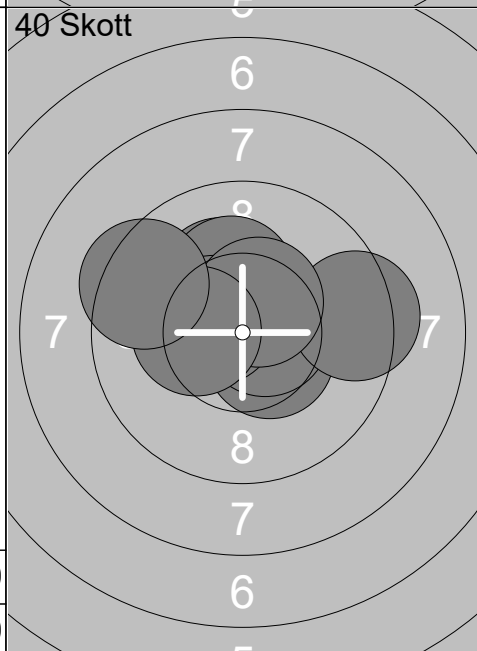

31: 10.5x	↘
32: 10.5x	↘
33: 10.6x	→
34: 10.2x	↗
35: 9.4	→
36: 10.2x	↑
37: 10.5x	←
38: 10.5x	↗
39: 10.3x	←
40: 9.4	←
Serie	98
Total	398

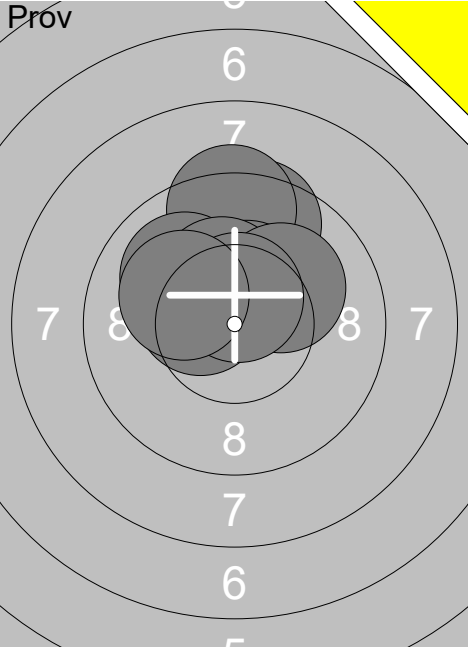
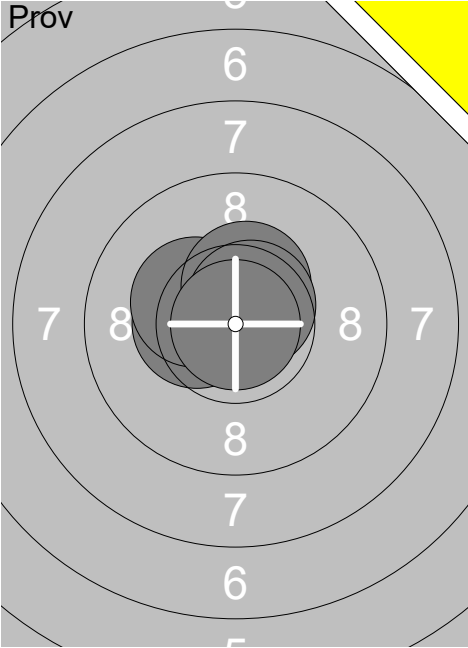
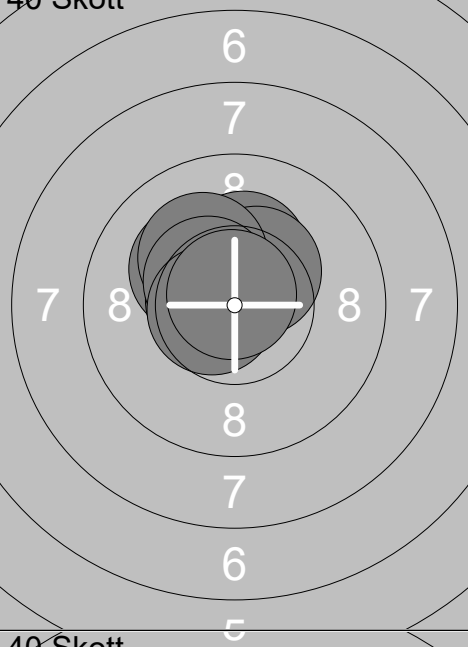
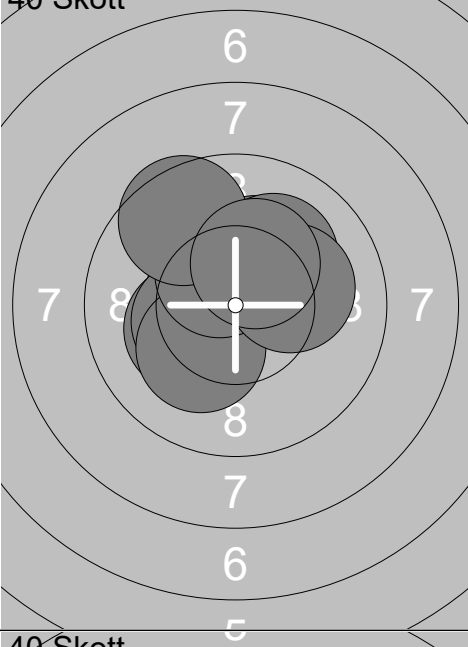
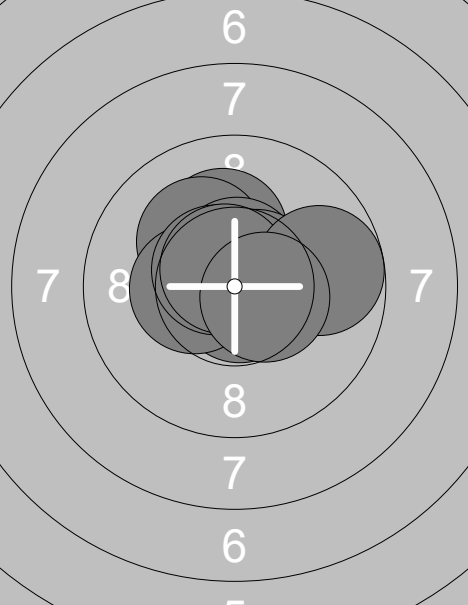
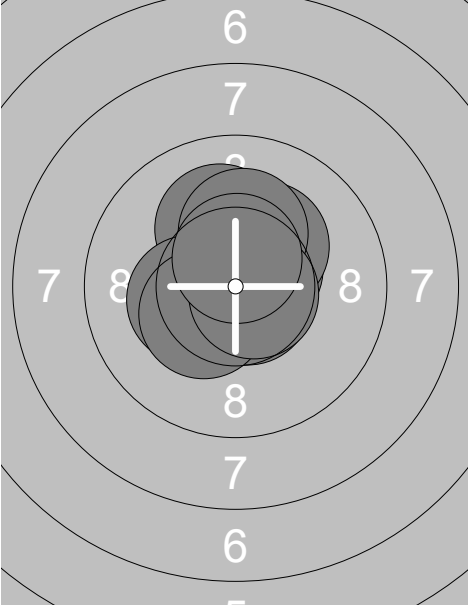
Skjutlag	Tavla	Anton Lind	
2	26	Ramselefors	Skoga-Ekshärad
04.11.2018	Vindelnskyttet 2018	Ramselefors SKF	Sitt Vä
Prov		Prov	
	1: 10.4x ↑ 2: 9.5 ↑ 3: 9.4 ↑ 4: 10.4x ↑ 5: 10.0 ↖ 6: 10.3x ↑ 7: 10.1 ↗ 8: 10.4x ↖ 9: 10.6x ↑ 10: 10.1 ↖ Serie 98 Total 0		11: 10.4x ← 12: 10.3x ↖ 13: 10.4x ↑ 14: 10.6x ↗ 15: 10.9x ↓ Serie 50 Total 0
40 Skott		40 Skott	
	1: 10.3x ↑ 2: 10.7x ↖ 3: 10.4x ↖ 4: 10.2x ↖ 5: 10.4x ↗ 6: 10.2x ↖ 7: 10.6x ↖ 8: 10.5x ↖ 9: 10.6x ↖ 10: 10.8x ↑ Serie 100 Total 100		11: 10.2x ↖ 12: 10.5x ↖ 13: 10.4x ↖ 14: 10.2x ↖ 15: 10.5x ↖ 16: 10.3x ↑ 17: 10.1 ↗ 18: 10.2x → 19: 9.6 ↖ 20: 10.3x ↑ Serie 99 Total 199
40 Skott		40 Skott	
	21: 10.8x ↓ 22: 10.2x ↑ 23: 10.2x ↖ 24: 10.6x ↑ 25: 10.4x ← 26: 10.6x ↖ 27: 10.6x ↗ 28: 10.7x ↖ 29: 9.8 → 30: 10.5x → Serie 99 Total 298		31: 10.1 ↑ 32: 10.7x ↘ 33: 10.5x ↗ 34: 10.3x ↗ 35: 10.3x ← 36: 10.2x ↑ 37: 10.9x ↖ 38: 10.4x ↖ 39: 10.7x → 40: 10.6x ↑ Serie 100 Total 398

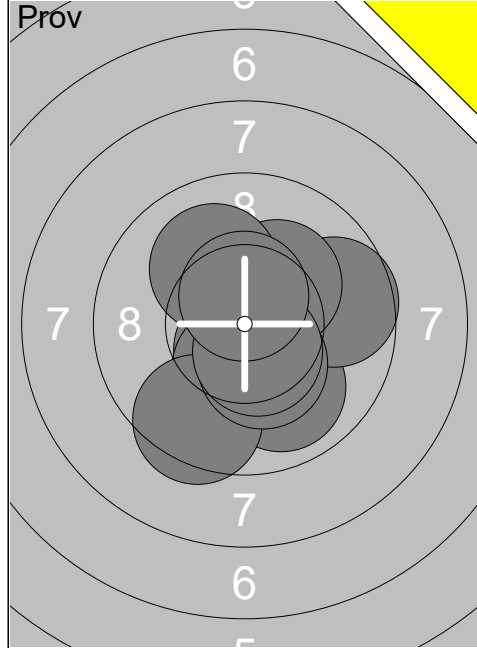

1:	10.6x ↓
2:	9.9 ↓
3:	9.7 →
4:	10.3x ↓
5:	9.5 ↓
6:	10.2x ↗
7:	10.3x ↓
8:	10.5x ↓
9:	10.1 ↗
10:	10.6x ↑
Serie	97
Total	0

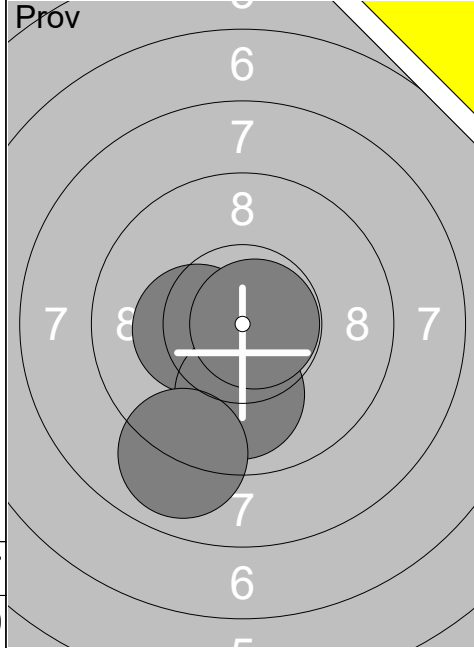

11:	10.8x ↓
12:	10.5x ↓
13:	10.3x ←
14:	10.0 ↓
15:	9.0 ↓
16:	10.8x →
Serie	59
Total	0

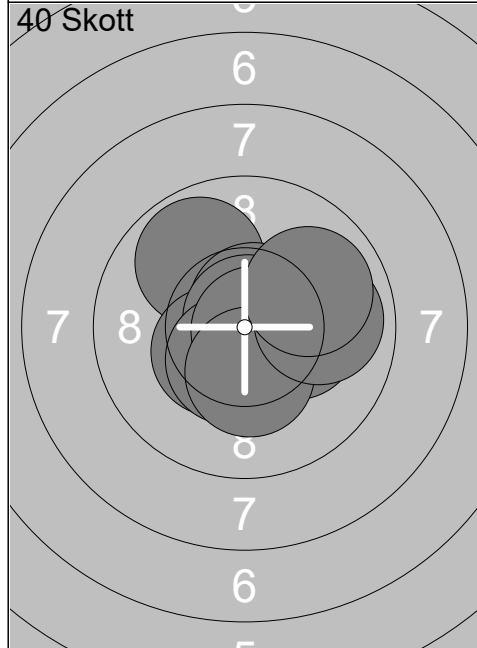

1:	9.9 ↖
2:	10.4x ↙
3:	10.6x ↗
4:	10.3x →
5:	10.8x ↗
6:	10.5x ↓
7:	10.8x →
8:	10.3x ↓
9:	9.9 →
10:	9.9 ↗
Serie	97
Total	97

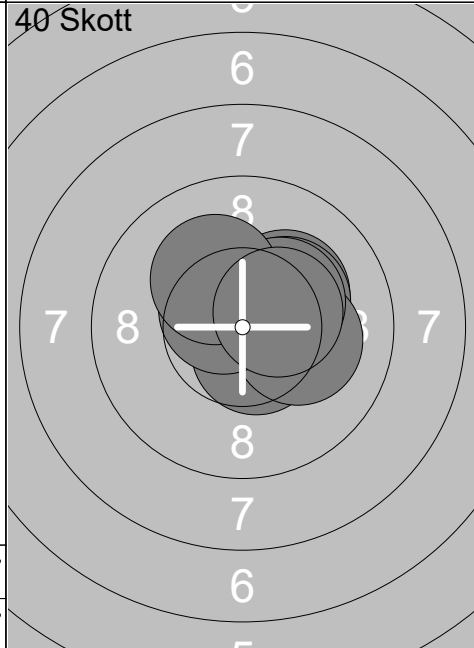

11:	10.4x →
12:	10.6x ↓
13:	10.2x ↗
14:	10.3x ↗
15:	10.4x ↖
16:	10.2x →
17:	10.3x ↗
18:	10.6x ↖
19:	10.2x ↖
20:	10.4x →
Serie	100
Total	197

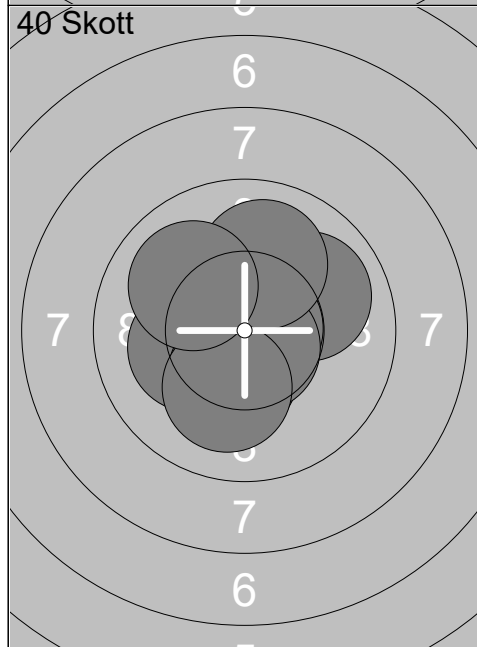

21:	10.6x ↙
22:	10.7x ↓
23:	10.2x ←
24:	10.0 ↗
25:	10.8x →
26:	10.3x ↓
27:	10.7x ↓
28:	10.0 ↑
29:	10.1 ↓
30:	10.0 ↖
Serie	100
Total	297

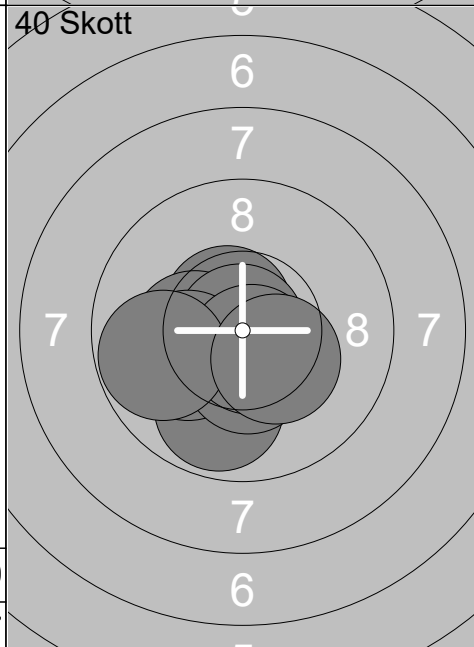

31:	10.6x ↖
32:	9.8 ↓
33:	10.3x ←
34:	10.7x ↓
35:	10.9x ↖
36:	10.1 ←
37:	10.4x ↓
38:	10.7x ↓
39:	9.8 ←
40:	10.3x ↘
Serie	98
Total	395

Skjutlag	Tavla	Erika Augustsson	
2	29		
Ramselefors	Vännäs	Sitt	Vb
04.11.2018	Vindelnskyttet 2018	Ramselefors SKF	
Prov 	1: 9.5 ↘	Prov 	11: 10.7x ↘
	2: 10.0 →		12: 10.6x ↑
	3: 10.1 →		
	4: 10.0 ↘		
	5: 10.7x ↙		
	6: 10.6x →		
	7: 10.3x ↙		
	8: 10.1 ↓		
	9: 10.6x ↓		
	10: 10.4x →		
	Serie 99		Serie 20
	Total 0		Total 0
40 Skott 	1: 10.0 ←	40 Skott 	11: 10.7x ↙
	2: 10.5x ↓		12: 10.7x ↓
	3: 10.4x →		13: 10.2x ↙
	4: 10.5x →		14: 10.5x ↗
	5: 10.5x ↘		15: 10.6x ↙
	6: 10.9x ↗		16: 10.8x ↓
	7: 10.4x ↓		17: 10.4x ↙
	8: 10.9x ↗		18: 10.4x ↑
	9: 10.0 ↓		19: 10.8x ↓
	10: 10.5x ↗		20: 10.5x ↓
	Serie 100		Serie 100
	Total 100		Total 200
40 Skott 	21: 10.3x ↙	40 Skott 	31: 10.5x ↙
	22: 10.6x ↙		32: 10.6x →
	23: 10.8x ↗		33: 10.9x ↙
	24: 10.5x ↙		34: 10.7x ↓
	25: 10.2x ↙		35: 10.1 ↘
	26: 10.8x ↓		36: 10.5x ↙
	27: 10.6x ↓		37: 10.4x ↓
	28: 10.7x ↓		38: 10.5x →
	29: 10.9x ↓		39: 10.7x ↓
	30: 10.5x ↓		40: 10.6x ↓
	Serie 100		Serie 100
	Total 300		Total 400

Skjutlag	Tavla	Beatrice Andersson					
2	30	Ramselefors	Ramselefors	Rem	Vb		
04.11.2018	Vindelnskyttet 2018	Ramselefors SKF					
Prov 	1: 10.4x ↘ 2: 10.7x ↑ 3: 10.5x → 4: 10.3x → 5: 10.6x → 6: 10.2x → 7: 10.3x ↓ 8: 10.7x ↓ 9: 10.7x ↓ 10: 10.2x ↓	40 Skott 	1: 10.7x ↗ 2: 10.0 → 3: 10.5x ↙ 4: 10.6x ↗ 5: 10.3x ↙ 6: 9.5 ↘ 7: 10.5x ↙ 8: 10.2x ↘ 9: 9.7 ↘ 10: 10.5x ↙	Serie	100	Serie	98
	Total		0	Total	98		
	40 Skott 		11: 10.7x ↓ 12: 10.4x ↓ 13: 10.4x ↗ 14: 10.6x ↙ 15: 10.4x ↘ 16: 10.3x ↓ 17: 10.3x ↗ 18: 10.6x ↙ 19: 10.5x ↙ 20: 9.9 →	40 Skott 	21: 10.7x ↗ 22: 10.6x ↑ 23: 10.0 ↑ 24: 10.5x ↗ 25: 10.7x ↙ 26: 9.3 ← 27: 10.3x ↙ 28: 10.5x ↙ 29: 10.7x ↓ 30: 10.3x ↑	Serie	99
Total		197	Total		296		
40 Skott 		31: 10.5x ↗ 32: 10.2x ↓ 33: 10.2x ↙ 34: 10.3x → 35: 10.2x ↘ 36: 9.6 ↘ 37: 9.6 ← 38: 9.9 → 39: 9.7 ↓ 40: 10.2x ↘				Serie	96
	Total	392					

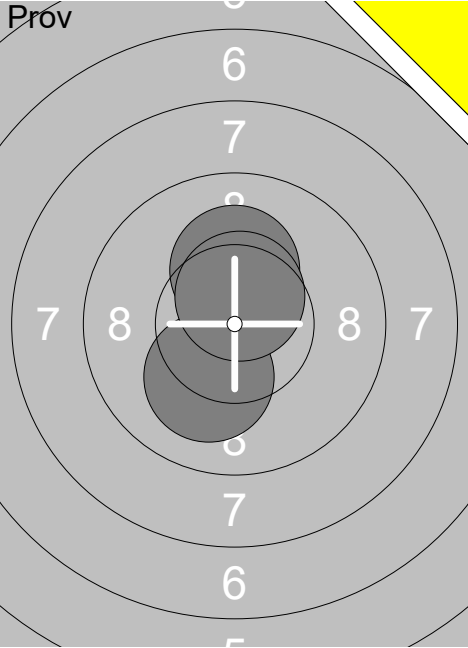
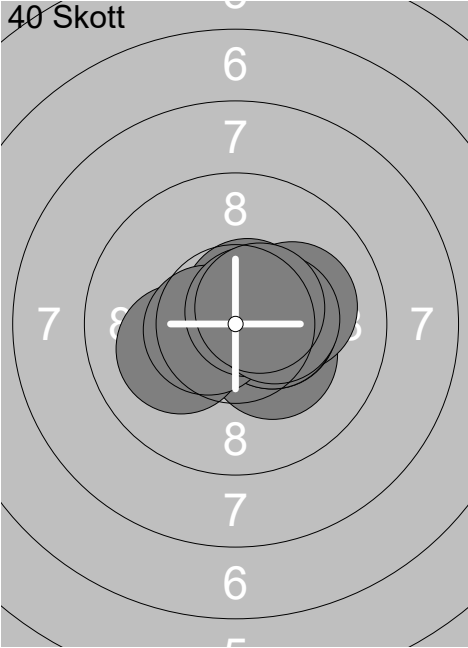
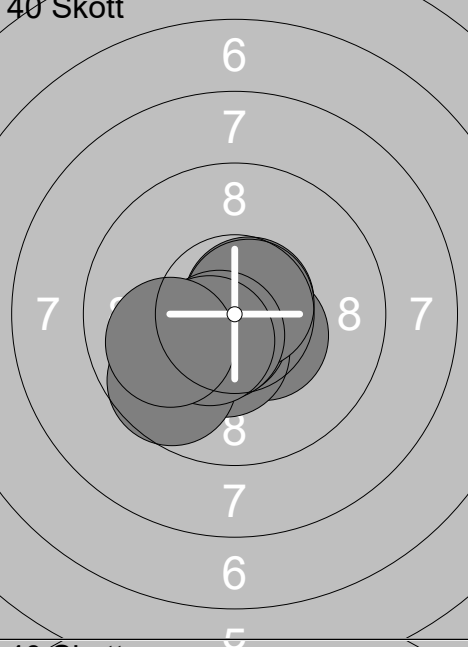
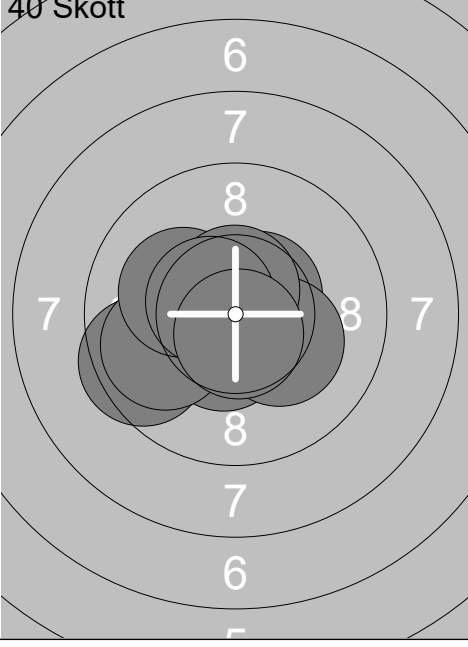
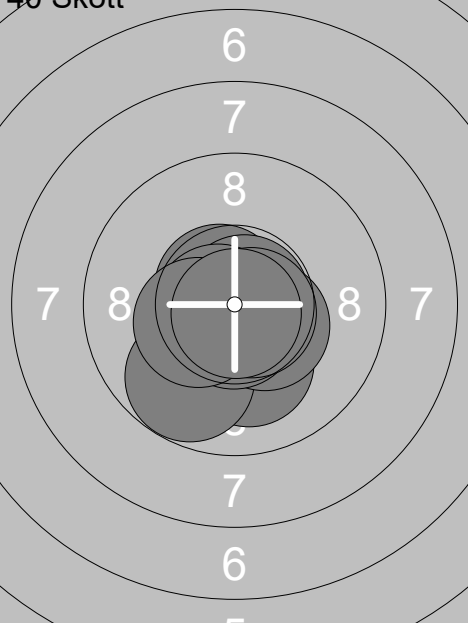
Skjuttag	Tavla	Jennifer Gustafsson			
2	31	Ramselefors	Ramselefors	Rem	Vb
04.11.2018	Vindelnskyttet 2018	Ramselefors SKF			
Prov 	1: 10.2x ↑ 2: 10.1 ↓ 3: 10.6x ↑	40 Skott 	1: 10.3x ↘ 2: 10.1 → 3: 10.4x → 4: 10.4x → 5: 10.1 ← 6: 10.6x ↗ 7: 10.6x ← 8: 10.7x ↗ 9: 10.4x → 10: 10.6x ↗	Serie 30 Total 0	Serie 100 Total 100
40 Skott 	11: 10.7x ↘ 12: 10.7x ↗ 13: 10.5x ↘ 14: 10.4x ↓ 15: 10.6x ↓ 16: 9.7 ← 17: 10.7x ↗ 18: 10.6x ↓ 19: 10.4x ↘ 20: 10.0 ←	40 Skott 	21: 10.6x ↗ 22: 10.6x ← 23: 10.5x ↓ 24: 9.5 ← 25: 9.9 ← 26: 10.2x ↖ 27: 10.2x ↘ 28: 10.6x ↑ 29: 10.6x ↖ 30: 10.7x ↓	Serie 99 Total 199	Serie 98 Total 297
40 Skott 	31: 10.7x ↖ 32: 10.8x → 33: 10.1 ↓ 34: 10.7x ← 35: 9.8 ↓ 36: 10.4x ↘ 37: 10.7x ↓ 38: 10.4x ↖ 39: 10.7x ↘ 40: 10.8x ↓			Serie 99 Total 396	

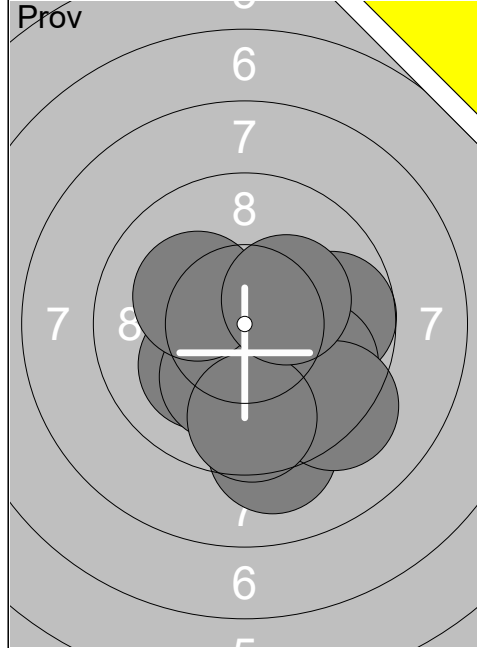

1:	9.7	→
2:	9.8	↘
3:	9.2	↓
4:	10.1	↓
5:	9.3	↘
6:	10.1	↙
7:	10.2x	↓
8:	10.2x	↖
9:	9.7	↓
10:	10.3x	↗
Serie		95
Total		0

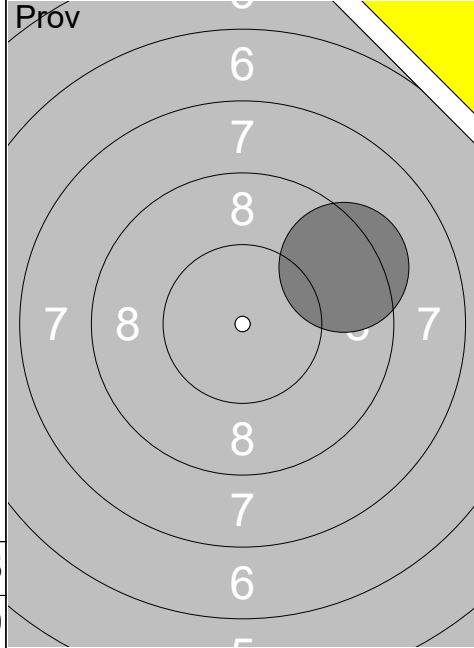

11:	9.3	↗
Serie		9
Total		0

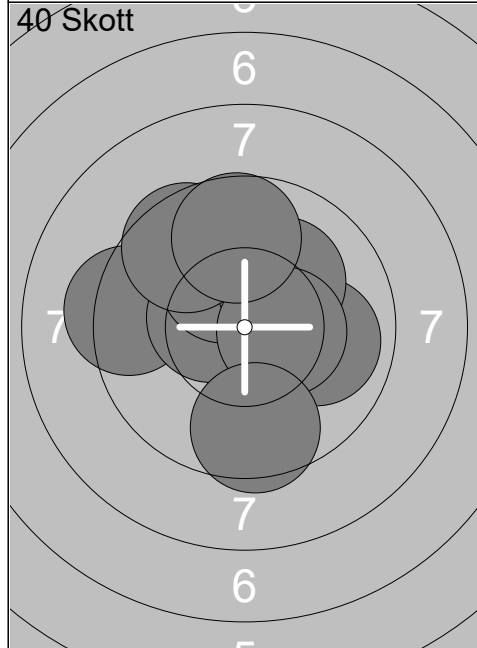

1:	9.3	←
2:	10.6x	↗
3:	9.9	→
4:	10.5x	↖
5:	10.2x	↗
6:	10.1	↗
7:	10.4x	→
8:	9.5	↓
9:	9.6	↗
10:	9.7	↑
Serie		95
Total		95

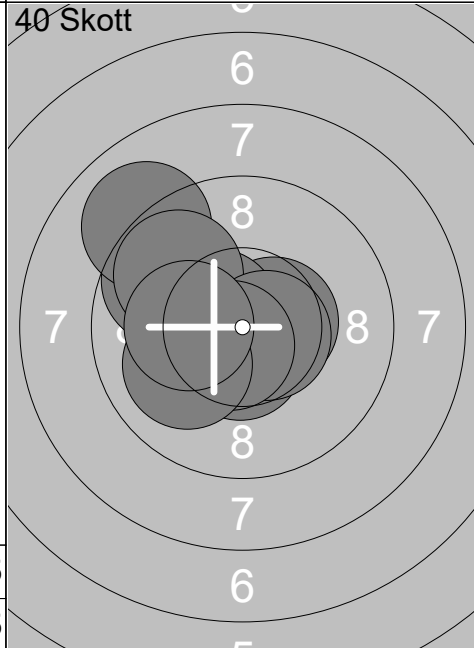

11:	10.6x	↓
12:	9.7	↖
13:	9.0	↖
14:	10.5x	→
15:	10.5x	↖
16:	9.8	↖
17:	10.6x	→
18:	10.6x	↘
19:	10.0	↙
20:	10.2x	↖
Serie		97
Total		192

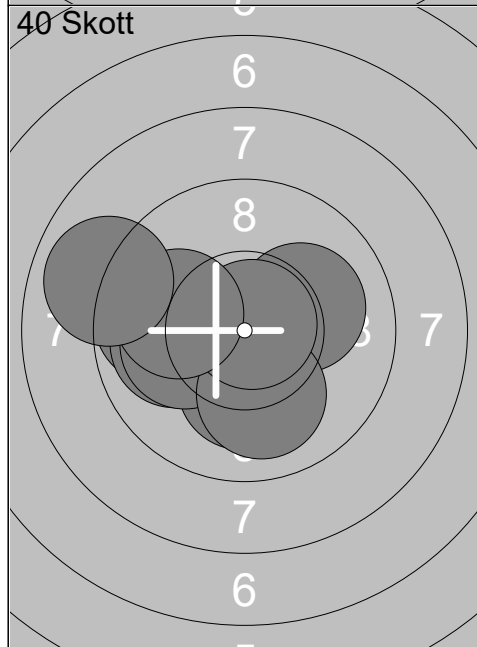

21:	10.2x	↓
22:	9.8	←
23:	10.9x	↓
24:	10.0	←
25:	10.1	←
26:	10.1	→
27:	10.0	↓
28:	10.8x	↗
29:	10.0	←
30:	8.9	←
Serie		97
Total		289

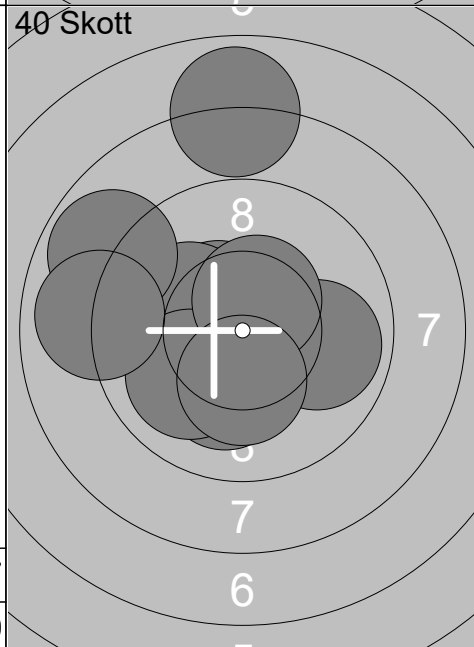

31:	9.9	→
32:	10.5x	↖
33:	10.2x	↓
34:	10.1	←
35:	10.0	↙
36:	8.9	↖
37:	7.9	↑
38:	9.0	←
39:	10.5x	↗
40:	10.3x	↓
Serie		93
Total		382

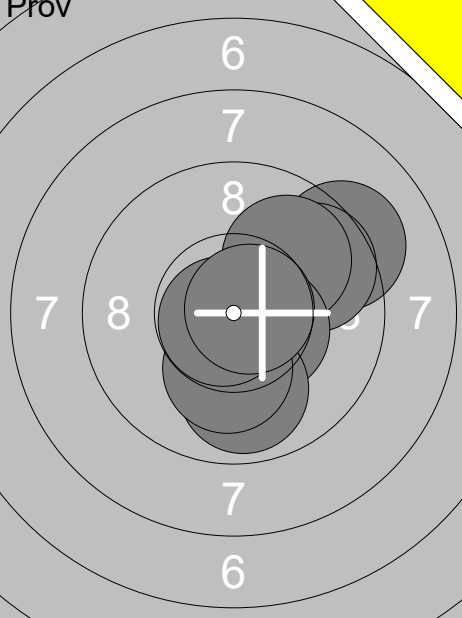
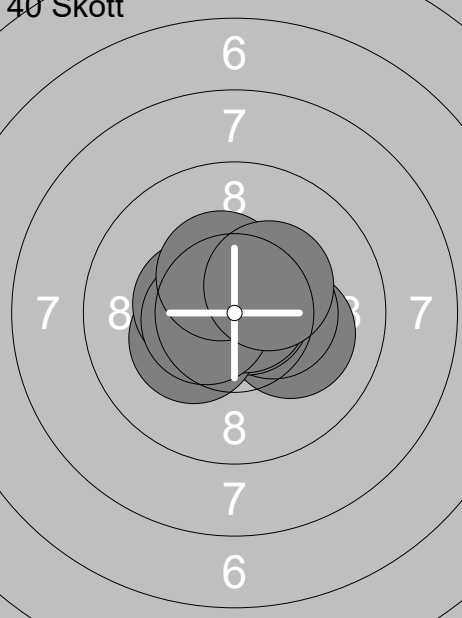
Prov 	40 Skott 	
1: 9.2 ↗ 2: 9.7 ↗ 3: 9.9 ↗ 4: 10.5x ➤ 5: 9.9 ↓ 6: 10.2x ↓ 7: 10.8x ↙ 8: 10.7x ➤	1: 10.6x ➤ 2: 10.1 ➤ 3: 10.4x ➤ 4: 10.8x ➤ 5: 10.3x ↙ 6: 10.8x ↗ 7: 10.4x ↙ 8: 10.5x ↙ 9: 10.4x ↗ 10: 10.3x ↗	
Serie 76	Serie 100	
Total 0	Total 100	

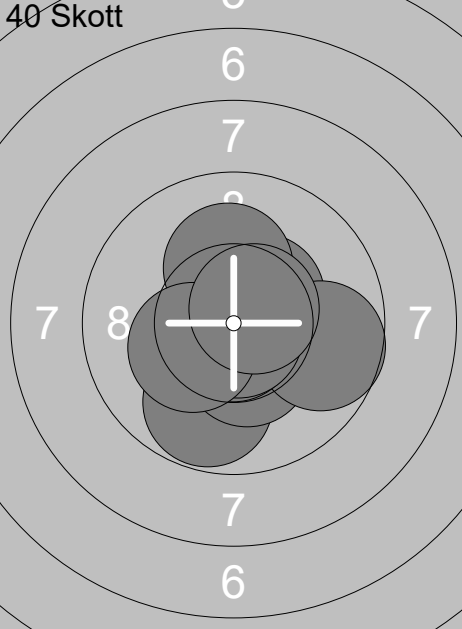
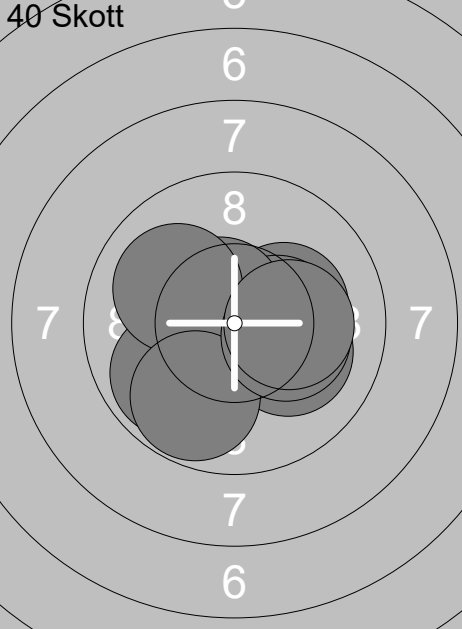
40 Skott 	40 Skott 	
11: 10.4x ↙ 12: 10.4x ↗ 13: 10.2x ↑ 14: 9.8 ↓ 15: 10.4x ↓ 16: 9.7 ➤ 17: 10.8x ↓ 18: 10.8x ↓ 19: 10.3x ↙ 20: 10.6x ↗	21: 9.9 ↙ 22: 10.1 ➤ 23: 10.8x ↗ 24: 10.2x ➤ 25: 10.4x ➤ 26: 10.6x ↗ 27: 10.0 ↗ 28: 9.8 ↓ 29: 10.2x ➤ 30: 10.2x ➤	
Serie 98	Serie 98	
Total 198	Total 296	

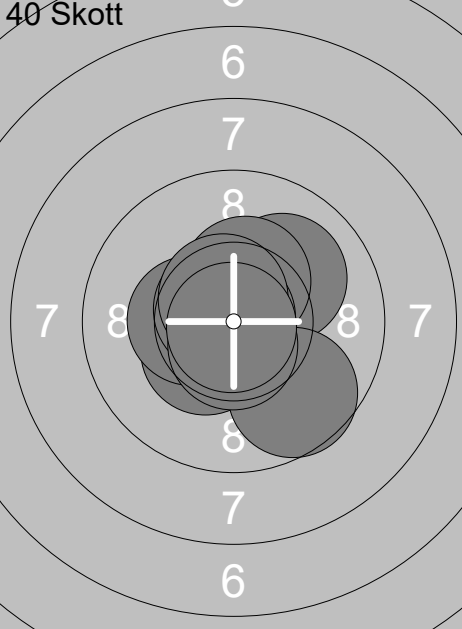
40 Skott 	
31: 10.4x ↙ 32: 10.0 ↗ 33: 10.4x ↙ 34: 9.7 ↓ 35: 10.4x ↑ 36: 10.7x ↗ 37: 10.9x ↗ 38: 10.6x ↗ 39: 10.6x ↓ 40: 10.9x ↓	
Serie 99	
Total 395	

Skjuttag	Tavla	Hanna Augustsson			
2	34	Ramselefors	Vännäs	Sitt	Vb
04.11.2018	Vindelnskyttet 2018	Ramselefors SKF			
Prov 	1: 10.0 ↓	Prov 	11: 10.4x ↓		
	2: 10.2x →		12: 10.0 ↓		
	3: 10.3x ↓		13: 10.1 ↑		
	4: 10.3x ↓		14: 10.4x ↓		
	5: 10.3x →		15: 10.4x →		
	6: 10.4x ↓		16: 10.0 ↓		
	7: 9.9 ↓		17: 10.4x ↓		
	8: 10.4x ↓		18: 10.3x ←		
	9: 10.7x ↖		19: 10.5x ↗		
	10: 10.3x ↓				
	Serie 99		Serie 90		
	Total 0		Total 0		
40 Skott 	1: 10.4x ↓	40 Skott 	11: 10.7x ↖		
	2: 10.3x ↗		12: 10.6x ←		
	3: 10.5x ↓		13: 10.2x ↖		
	4: 10.4x ↗		14: 10.6x ↓		
	5: 10.9x →		15: 10.8x ↗		
	6: 10.3x ↖		16: 10.6x ↓		
	7: 10.6x ←		17: 10.4x ↗		
	8: 10.4x ←		18: 10.3x ↓		
	9: 10.3x ↖		19: 10.7x ↑		
	10: 10.6x ↙		20: 10.5x ↖		
	Serie 100		Serie 100		
	Total 100		Total 200		
40 Skott 	21: 10.3x ↖	40 Skott 	31: 10.5x ↓		
	22: 9.9 ↑		32: 10.5x ↖		
	23: 10.0 ↑		33: 10.7x ↗		
	24: 10.6x ↓		34: 10.9x ←		
	25: 10.5x ↗		35: 10.5x ↗		
	26: 10.5x →		36: 10.1 ←		
	27: 10.3x ←		37: 10.5x ←		
	28: 10.3x ←		38: 10.1 ↖		
	29: 10.1 ←		39: 10.4x ↓		
	30: 10.4x ←		40: 10.8x ↓		
	Serie 99		Serie 100		
	Total 299		Total 399		

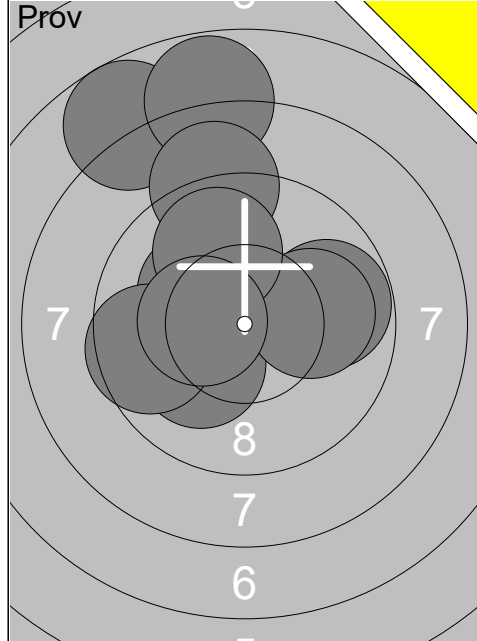

1:	7.7	↖
2:	7.8	↑
3:	9.0	↑
4:	10.2x	↖
5:	10.1	↙
6:	9.6	←
7:	9.8	→
8:	10.0	→
9:	9.9	↑
10:	10.4x	←
Serie		90
Total		0

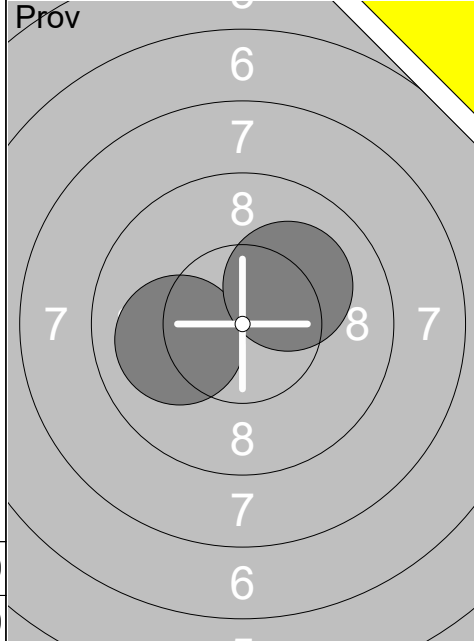

11:	10.0	←
12:	10.1	↗
Serie		20
Total		0

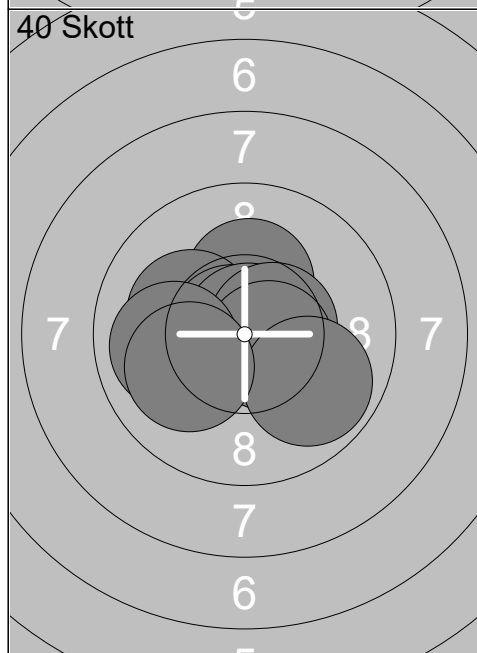

1:	10.1	←
2:	10.2x	↑
3:	10.2x	↖
4:	10.8x	↖
5:	10.9x	↗
6:	10.5x	→
7:	10.6x	→
8:	10.0	←
9:	9.9	↘
10:	10.1	←
Serie		99
Total		99

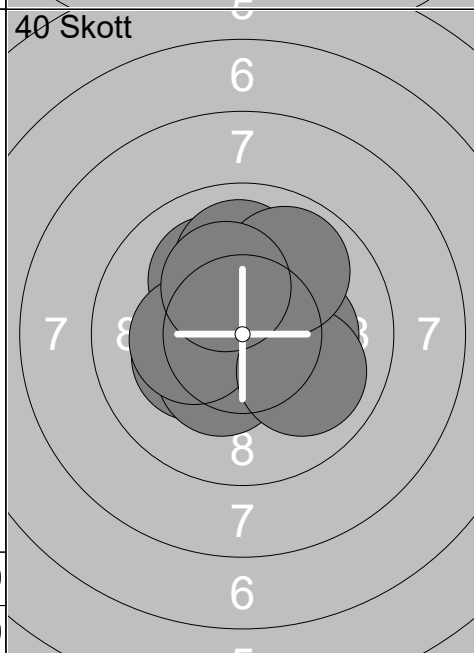

11:	10.1	↖
12:	10.6x	↑
13:	10.2x	↖
14:	10.4x	↙
15:	10.0	↑
16:	10.2x	→
17:	10.3x	←
18:	10.0	↘
19:	9.9	↗
20:	10.2x	↑
Serie		99
Total		198

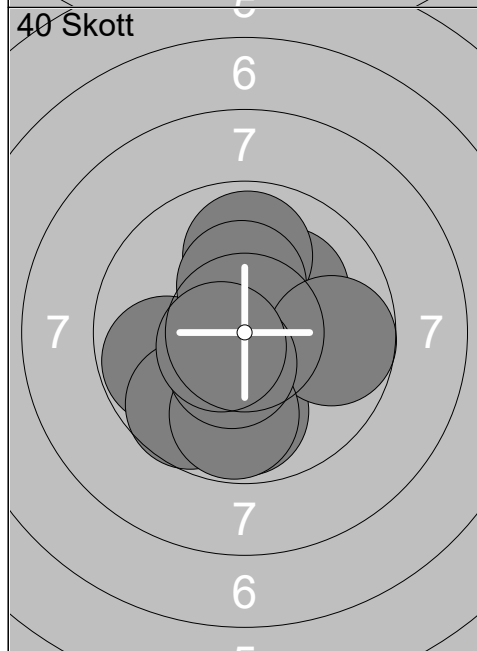

21:	9.9	↓
22:	10.2x	↗
23:	9.8	←
24:	9.9	↑
25:	10.3x	↑
26:	9.7	↙
27:	9.7	→
28:	9.8	↓
29:	10.5x	↙
30:	10.6x	↖
Serie		94
Total		292

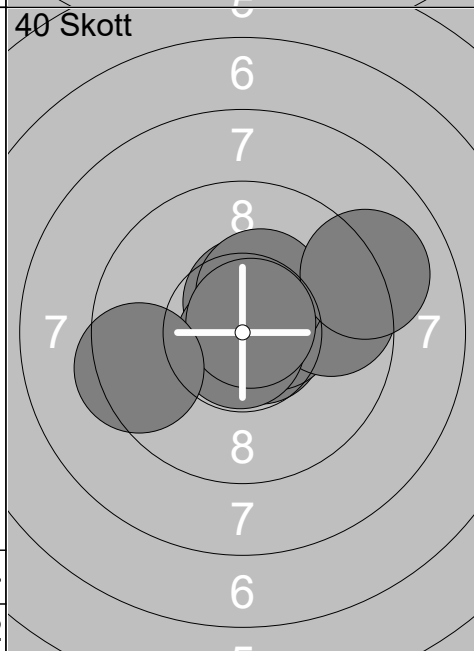

31:	10.7x	→
32:	10.5x	→
33:	10.6x	↑
34:	9.7	→
35:	10.5x	↑
36:	10.4x	↑
37:	9.1	↗
38:	10.8x	↓
39:	10.8x	↗
40:	9.4	←
Serie		97
Total		389

Skjuttag	Tavla	Oskar Nygren			
2	36	Ramselefors	Ramselefors	Funk	Vb
04.11.2018	Vindelnskyttet 2018	Ramselefors SKF			
Prov 	1: 9.9 →	40 Skott 	1: 10.1 ↗		
	2: 10.1 ↓		2: 9.4 ↓		
	3: 9.2 ↓		3: 10.1 ↓		
	4: 8.9 ←		4: 8.2 ↗		
	5: 9.8 ↗		5: 9.4 ↗		
			6: 8.5 →		
			7: 10.1 →		
			8: 9.3 ↗		
			9: 9.5 ↓		
			10: 10.1 ↑		
	Serie 45		Serie 92		
	Total 0		Total 92		
40 Skott 	11: 6.5 ↑	40 Skott 	21: 8.7 ↗		
	12: 8.3 →		22: 9.3 ↗		
	13: 9.2 ←		23: 8.8 →		
	14: 8.4 ↗		24: 8.7 ↗		
	15: 9.4 ↑		25: 10.6x ←		
	16: 8.6 →		26: 10.6x ←		
	17: 10.4x ↓		27: 10.0 ←		
	18: 10.0 →		28: 9.9 →		
	19: 10.0 ↓		29: 8.1 →		
	20: 7.7 →		30: 7.2 ↗		
	Serie 85		Serie 87		
	Total 177		Total 264		
40 Skott 	31: 10.0 ↓				
	32: 7.6 ↗				
	33: 7.5 ←				
	34: 8.6 ↗				
	35: 7.8 ←				
	36: 7.5 ↗				
	37: 8.0 ↗				
	38: 10.7x ←				
	39: 9.5 ↑				
	40: 9.1 ←				
	Serie 82				
	Total 346				

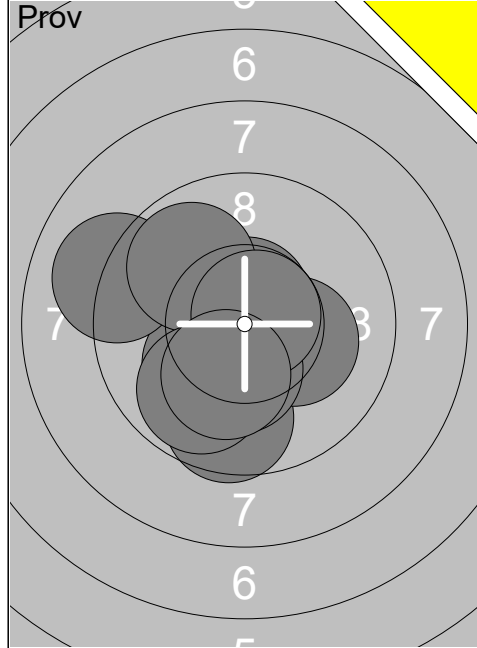

1: 9.6 ↓
2: 10.2x →
3: 10.6x ↑
4: 10.2x ↙
5: 10.3x ↓
6: 9.1 ←
7: 9.9 ↗
8: 9.9 ↓
9: 10.8x ↗
10: 10.2x ↓
Serie 96
Total 0

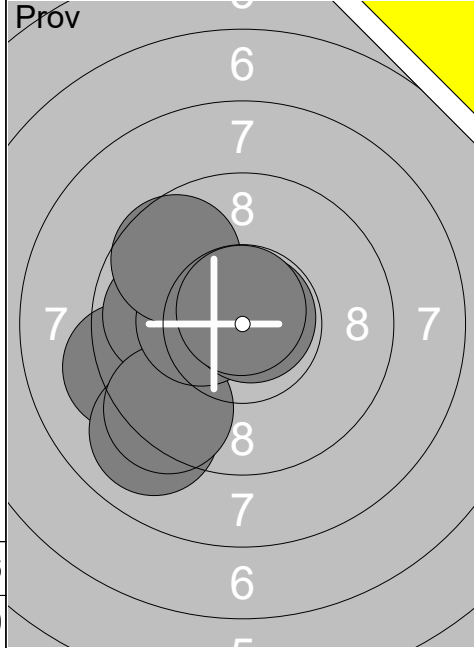

11: 9.2 ←
12: 9.0 ↙
13: 9.9 ←
14: 9.4 ↙
15: 10.4x ←
16: 9.7 ↖
17: 10.8x ↗
18: 10.8x ↑
Serie 75
Total 0

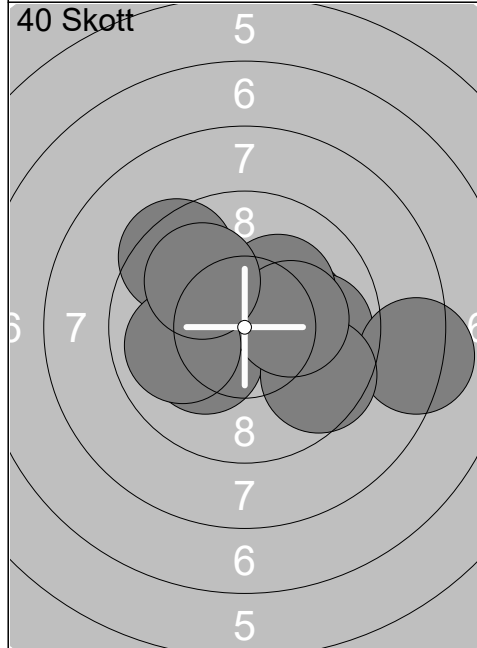

1: 10.2x →
2: 9.9 →
3: 8.3 →
4: 10.2x ↙
5: 9.6 ↘
6: 10.2x ↗
7: 10.2x →
8: 9.4 ↖
9: 10.0 ←
10: 10.0 ↖
Serie 95
Total 95

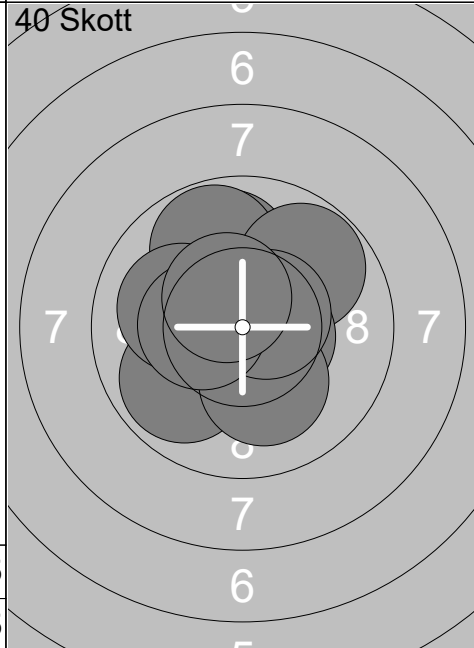

11: 9.9 ↙
12: 9.9 ↑
13: 9.8 ↑
14: 9.8 ↗
15: 10.5x →
16: 10.2x ↓
17: 10.1 ←
18: 10.6x ↗
19: 10.4x ←
20: 10.5x ↖
Serie 96
Total 191

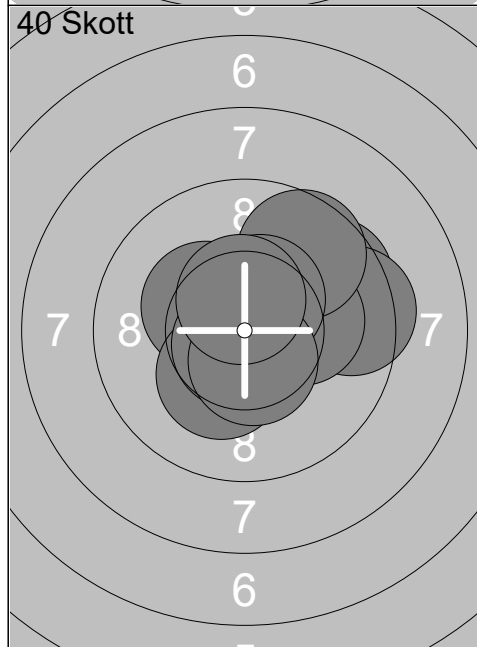

21: 9.6 ↗
22: 10.3x ↖
23: 9.4 →
24: 10.2x →
25: 10.3x ↓
26: 10.7x ↙
27: 9.6 ↗
28: 10.5x ↗
29: 10.5x ↓
30: 10.5x ↑
Serie 97
Total 288

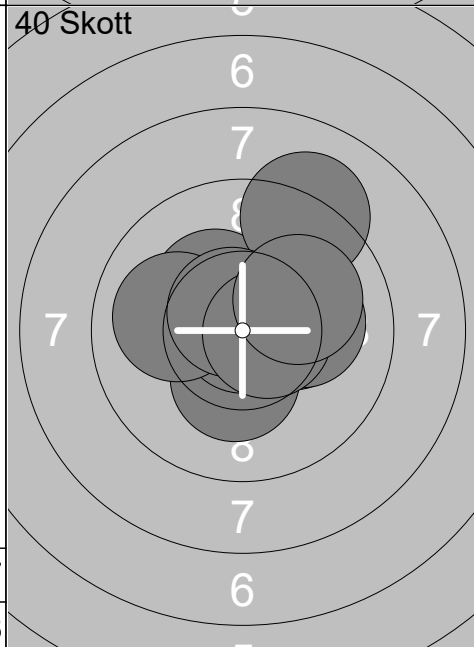

31: 10.3x ↖
32: 10.3x →
33: 10.1 →
34: 10.3x ↓
35: 10.9x ↗
36: 9.1 ↗
37: 10.0 ←
38: 10.7x ↖
39: 10.6x →
40: 10.1 ↗
Serie 99
Total 387

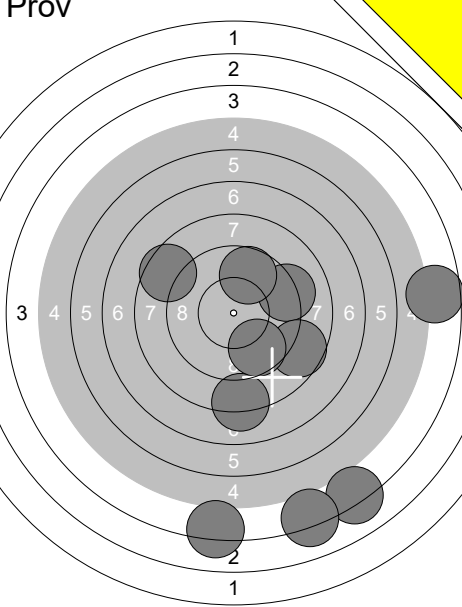
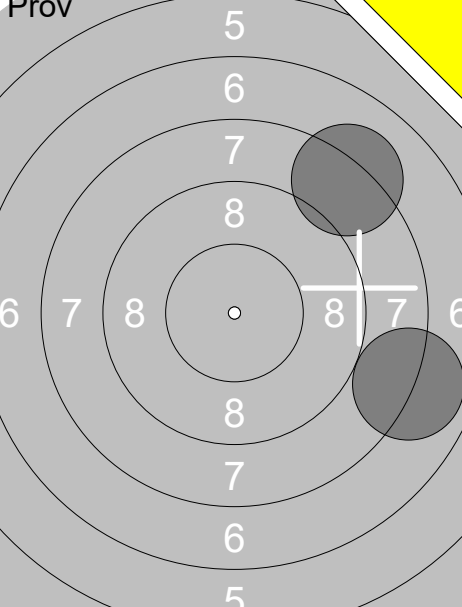
Prov 	<table style="width:100%; border-collapse: collapse;"> <tr><td>1:</td><td>4.1</td><td>↘</td></tr> <tr><td>2:</td><td>8.2</td><td>↓</td></tr> <tr><td>3:</td><td>4.1</td><td>↘</td></tr> <tr><td>4:</td><td>9.2</td><td>→</td></tr> <tr><td>5:</td><td>8.5</td><td>↖</td></tr> <tr><td>6:</td><td>9.7</td><td>↗</td></tr> <tr><td>7:</td><td>8.7</td><td>↘</td></tr> <tr><td>8:</td><td>4.6</td><td>→</td></tr> <tr><td>9:</td><td>4.2</td><td>↓</td></tr> <tr><td>10:</td><td>9.6</td><td>↘</td></tr> <tr><td>Serie</td><td>67</td><td></td></tr> <tr><td>Total</td><td>0</td><td></td></tr> </table>	1:	4.1	↘	2:	8.2	↓	3:	4.1	↘	4:	9.2	→	5:	8.5	↖	6:	9.7	↗	7:	8.7	↘	8:	4.6	→	9:	4.2	↓	10:	9.6	↘	Serie	67		Total	0		Prov  <table style="width:100%; border-collapse: collapse;"> <tr><td>11:</td><td>7.9</td><td>→</td></tr> <tr><td>12:</td><td>8.2</td><td>↗</td></tr> <tr><td>Serie</td><td>15</td><td></td></tr> <tr><td>Total</td><td>0</td><td></td></tr> </table>	11:	7.9	→	12:	8.2	↗	Serie	15		Total	0	
1:	4.1	↘																																																
2:	8.2	↓																																																
3:	4.1	↘																																																
4:	9.2	→																																																
5:	8.5	↖																																																
6:	9.7	↗																																																
7:	8.7	↘																																																
8:	4.6	→																																																
9:	4.2	↓																																																
10:	9.6	↘																																																
Serie	67																																																	
Total	0																																																	
11:	7.9	→																																																
12:	8.2	↗																																																
Serie	15																																																	
Total	0																																																	

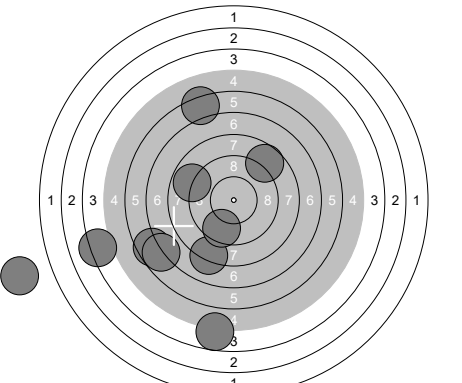
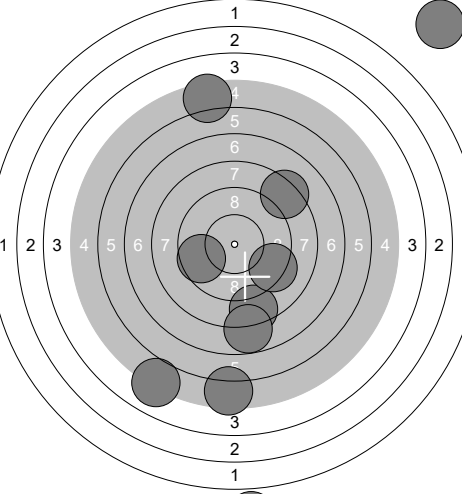
40 Skott 	<table style="width:100%; border-collapse: collapse;"> <tr><td>1:</td><td>6.3</td><td>↗</td></tr> <tr><td>2:</td><td>4.2</td><td>←</td></tr> <tr><td>3:</td><td>0.0</td><td>←</td></tr> <tr><td>4:</td><td>4.7</td><td>↓</td></tr> <tr><td>5:</td><td>6.5</td><td>←</td></tr> <tr><td>6:</td><td>8.8</td><td>←</td></tr> <tr><td>7:</td><td>8.7</td><td>↗</td></tr> <tr><td>8:</td><td>8.1</td><td>↓</td></tr> <tr><td>9:</td><td>9.5</td><td>↓</td></tr> <tr><td>10:</td><td>6.8</td><td>←</td></tr> <tr><td>Serie</td><td>59</td><td></td></tr> <tr><td>Total</td><td>59</td><td></td></tr> </table>	1:	6.3	↗	2:	4.2	←	3:	0.0	←	4:	4.7	↓	5:	6.5	←	6:	8.8	←	7:	8.7	↗	8:	8.1	↓	9:	9.5	↓	10:	6.8	←	Serie	59		Total	59		40 Skott  <table style="width:100%; border-collapse: collapse;"> <tr><td>11:</td><td>5.0</td><td>↘</td></tr> <tr><td>12:</td><td>8.4</td><td>↓</td></tr> <tr><td>13:</td><td>5.5</td><td>↓</td></tr> <tr><td>14:</td><td>5.4</td><td>↗</td></tr> <tr><td>15:</td><td>9.3</td><td>↘</td></tr> <tr><td>16:</td><td>8.3</td><td>↗</td></tr> <tr><td>17:</td><td>0.0</td><td>↓</td></tr> <tr><td>18:</td><td>7.7</td><td>↓</td></tr> <tr><td>19:</td><td>9.6</td><td>←</td></tr> <tr><td>20:</td><td>0.0</td><td>↗</td></tr> <tr><td>Serie</td><td>56</td><td></td></tr> <tr><td>Total</td><td>115</td><td></td></tr> </table>	11:	5.0	↘	12:	8.4	↓	13:	5.5	↓	14:	5.4	↗	15:	9.3	↘	16:	8.3	↗	17:	0.0	↓	18:	7.7	↓	19:	9.6	←	20:	0.0	↗	Serie	56		Total	115	
1:	6.3	↗																																																																								
2:	4.2	←																																																																								
3:	0.0	←																																																																								
4:	4.7	↓																																																																								
5:	6.5	←																																																																								
6:	8.8	←																																																																								
7:	8.7	↗																																																																								
8:	8.1	↓																																																																								
9:	9.5	↓																																																																								
10:	6.8	←																																																																								
Serie	59																																																																									
Total	59																																																																									
11:	5.0	↘																																																																								
12:	8.4	↓																																																																								
13:	5.5	↓																																																																								
14:	5.4	↗																																																																								
15:	9.3	↘																																																																								
16:	8.3	↗																																																																								
17:	0.0	↓																																																																								
18:	7.7	↓																																																																								
19:	9.6	←																																																																								
20:	0.0	↗																																																																								
Serie	56																																																																									
Total	115																																																																									

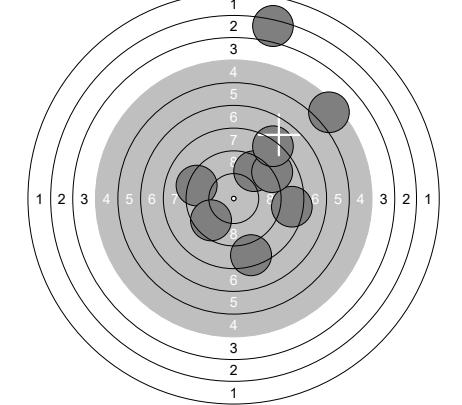
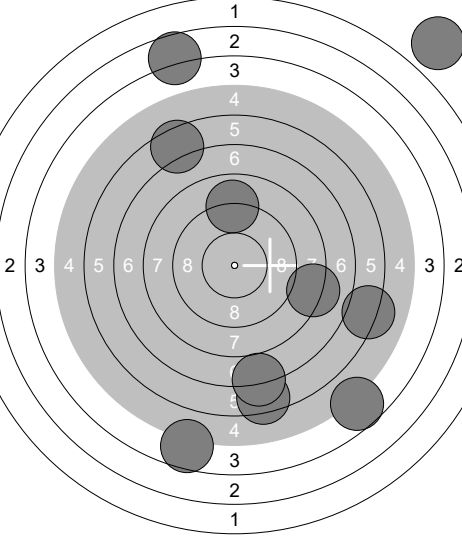
40 Skott 	<table style="width:100%; border-collapse: collapse;"> <tr><td>21:</td><td>8.4</td><td>→</td></tr> <tr><td>22:</td><td>5.3</td><td>↗</td></tr> <tr><td>23:</td><td>9.4</td><td>↗</td></tr> <tr><td>24:</td><td>9.2</td><td>←</td></tr> <tr><td>25:</td><td>8.9</td><td>↗</td></tr> <tr><td>26:</td><td>8.1</td><td>↗</td></tr> <tr><td>27:</td><td>9.5</td><td>←</td></tr> <tr><td>28:</td><td>0.0</td><td>↗</td></tr> <tr><td>29:</td><td>8.3</td><td>↓</td></tr> <tr><td>30:</td><td>3.2</td><td>↗</td></tr> <tr><td>Serie</td><td>67</td><td></td></tr> <tr><td>Total</td><td>182</td><td></td></tr> </table>	21:	8.4	→	22:	5.3	↗	23:	9.4	↗	24:	9.2	←	25:	8.9	↗	26:	8.1	↗	27:	9.5	←	28:	0.0	↗	29:	8.3	↓	30:	3.2	↗	Serie	67		Total	182		40 Skott  <table style="width:100%; border-collapse: collapse;"> <tr><td>31:</td><td>3.7</td><td>↗</td></tr> <tr><td>32:</td><td>4.6</td><td>↓</td></tr> <tr><td>33:</td><td>4.7</td><td>↘</td></tr> <tr><td>34:</td><td>8.2</td><td>→</td></tr> <tr><td>35:</td><td>9.0</td><td>↗</td></tr> <tr><td>36:</td><td>6.5</td><td>↗</td></tr> <tr><td>37:</td><td>0.0</td><td>↗</td></tr> <tr><td>38:</td><td>6.4</td><td>↓</td></tr> <tr><td>39:</td><td>6.1</td><td>→</td></tr> <tr><td>40:</td><td>7.0</td><td>↓</td></tr> <tr><td>Serie</td><td>53</td><td></td></tr> <tr><td>Total</td><td>235</td><td></td></tr> </table>	31:	3.7	↗	32:	4.6	↓	33:	4.7	↘	34:	8.2	→	35:	9.0	↗	36:	6.5	↗	37:	0.0	↗	38:	6.4	↓	39:	6.1	→	40:	7.0	↓	Serie	53		Total	235	
21:	8.4	→																																																																								
22:	5.3	↗																																																																								
23:	9.4	↗																																																																								
24:	9.2	←																																																																								
25:	8.9	↗																																																																								
26:	8.1	↗																																																																								
27:	9.5	←																																																																								
28:	0.0	↗																																																																								
29:	8.3	↓																																																																								
30:	3.2	↗																																																																								
Serie	67																																																																									
Total	182																																																																									
31:	3.7	↗																																																																								
32:	4.6	↓																																																																								
33:	4.7	↘																																																																								
34:	8.2	→																																																																								
35:	9.0	↗																																																																								
36:	6.5	↗																																																																								
37:	0.0	↗																																																																								
38:	6.4	↓																																																																								
39:	6.1	→																																																																								
40:	7.0	↓																																																																								
Serie	53																																																																									
Total	235																																																																									

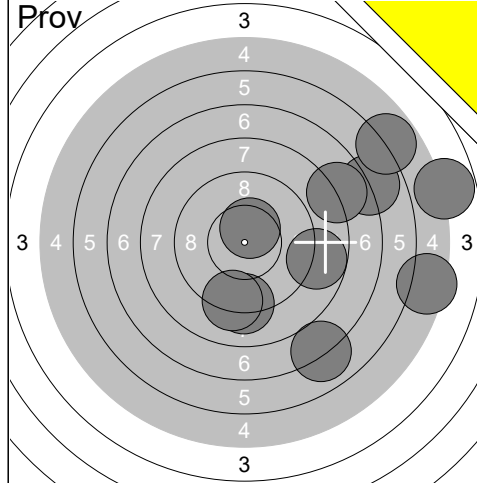

1:	9.1	↓
2:	6.9	→
3:	4.8	→
4:	7.8	→
5:	9.2	↓
6:	5.8	→
7:	7.0	↓
8:	5.4	→
9:	8.8	→
10:	10.5x	↑
Serie		70
Total		0

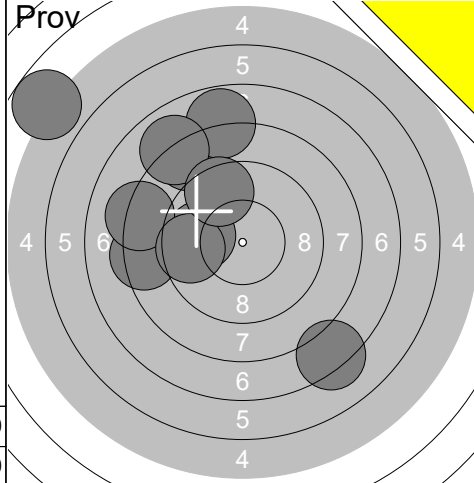

11:	4.8	↖
12:	8.4	←
13:	9.9	←
14:	8.3	↗
15:	8.2	←
16:	7.8	↑
17:	7.2	↓
18:	9.6	←
19:	8.0	↗
20:	9.5	↗
Serie		77
Total		0

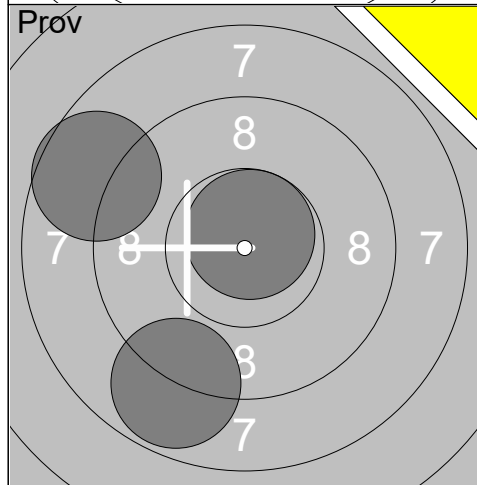

21:	8.7	↖
22:	10.7x	↑
23:	8.8	↓
Serie		26
Total		0

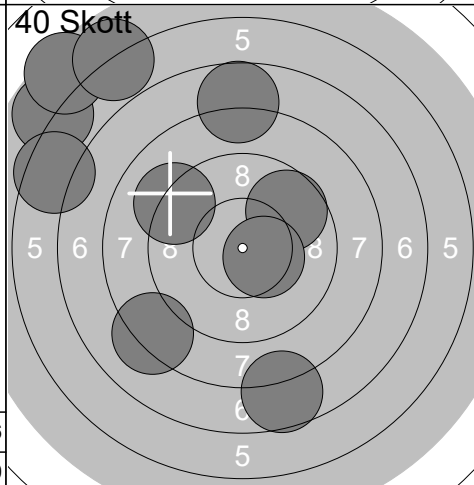

1:	7.7	↓
2:	5.8	↗
3:	8.2	↙
4:	9.7	↗
5:	10.4x	→
6:	5.4	↗
7:	9.1	↗
8:	6.5	↗
9:	5.9	↗
10:	7.7	↑
Serie		71
Total		71

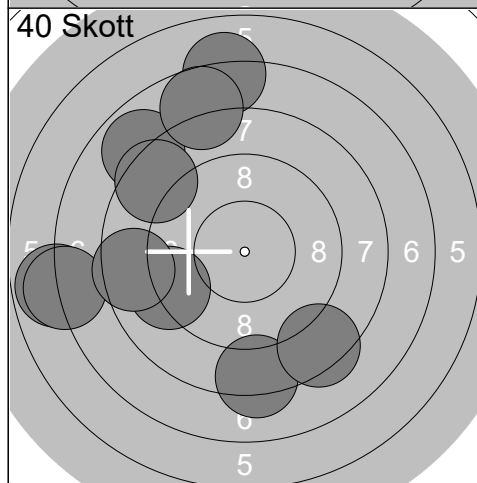

11:	7.9	↗
12:	8.2	↓
13:	6.8	←
14:	7.0	←
15:	7.1	↑
16:	9.1	←
17:	8.5	↗
18:	8.4	↓
19:	8.5	←
20:	7.7	↑
Serie		75
Total		146

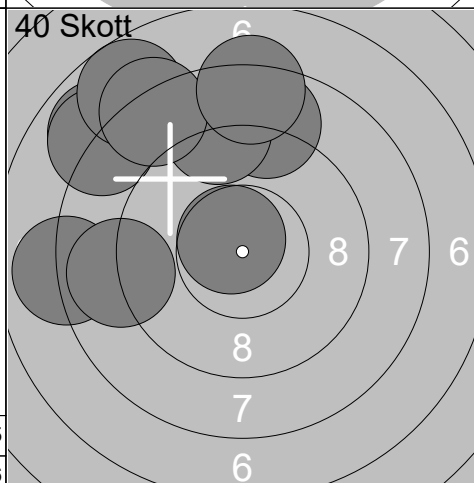

21:	8.0	←
22:	8.8	↑
23:	8.9	↑
24:	8.9	←
25:	7.9	↗
26:	8.0	↗
27:	7.7	↗
28:	8.2	↗
29:	8.3	↑
30:	10.7x	↗
Serie		80
Total		226

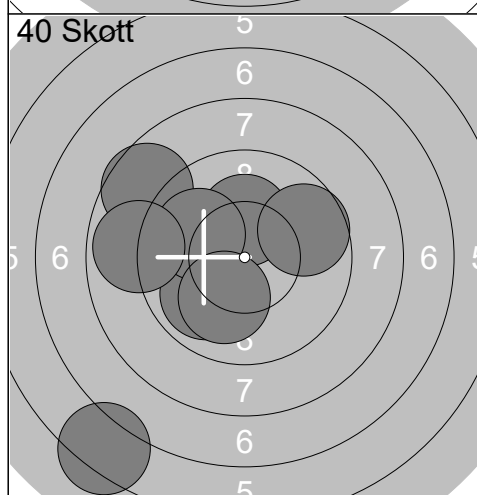

31:	9.4	←
32:	9.8	←
33:	10.2x	↑
34:	8.6	↗
35:	9.9	↙
36:	10.0	↗
37:	9.7	→
38:	6.3	↙
39:	10.1	↓
40:	8.9	←
Serie		88
Total		314

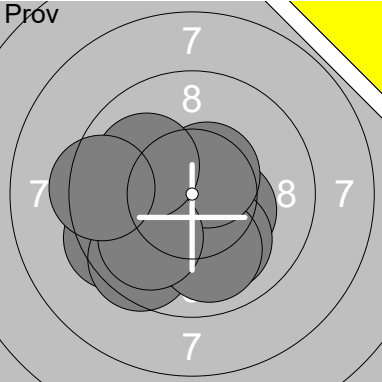
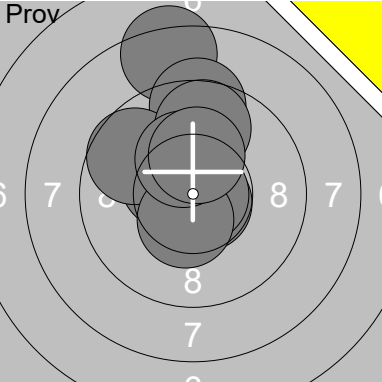
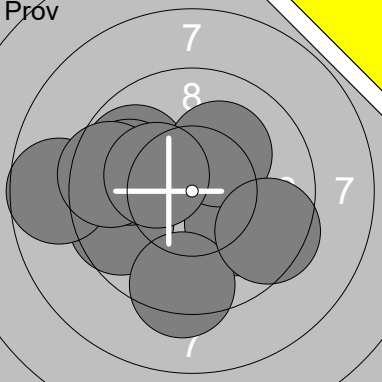
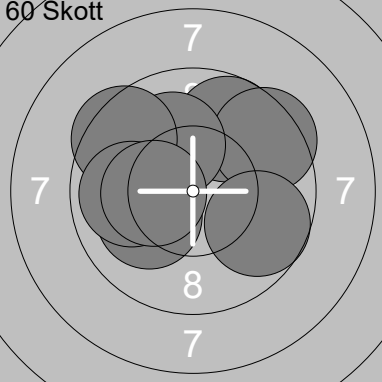
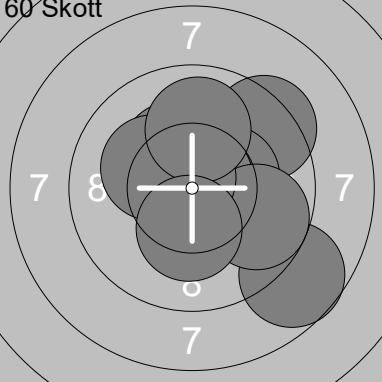
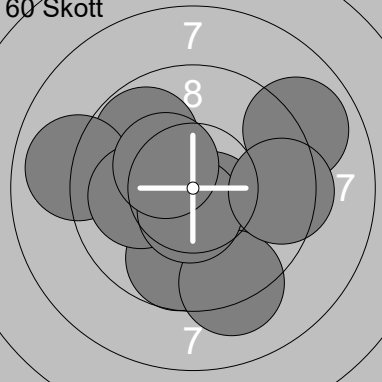
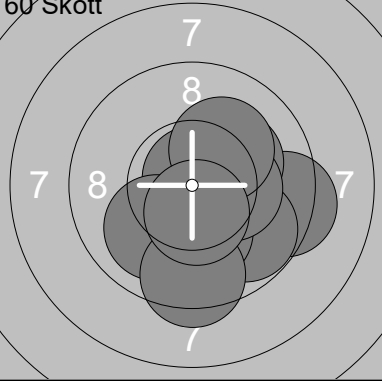
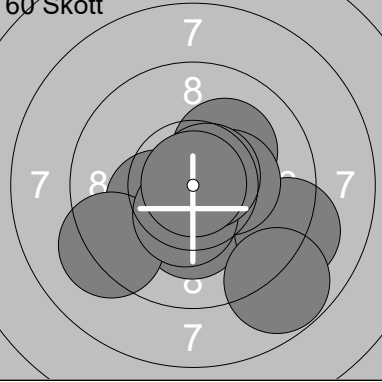
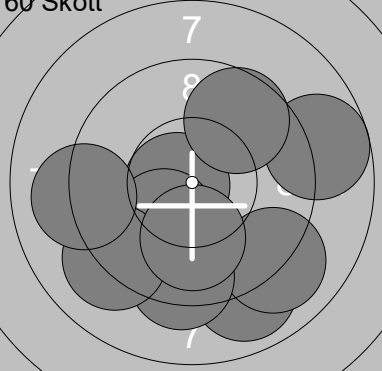
Skjuttlag 3	Tavla 1	Noelle Fessé			
Ramselefors		Gefle Frivilliga Skarp		13S	Gä
04.11.2018		Vindelnskyttet 2018		Ramselefors SKF	
	1: 9.5 ↙ 2: 9.5 ↘ 3: 10.3x → 4: 10.2x ↓ 5: 10.0 ↓ 6: 10.0 ↓ 7: 10.5x ↗ 8: 9.9 ↙ 9: 10.0 ↗ 10: 9.4 ←		11: 10.4x ↖ 12: 8.3 ↑ 13: 10.7x ↓ 14: 10.8x → 15: 9.3 ↑ 16: 9.7 ↖ 17: 9.7 ↑ 18: 10.5x ↓ 19: 10.3x ↑ 20: 10.2x ↑	Serie	99.3
Total		0.0		Serie	99.9
Total		0.0		Total	
	21: 9.8 ↖ 22: 10.0 → 23: 9.6 ← 24: 8.7 ← 25: 9.3 ↓ 26: 10.2x ↗ 27: 9.8 ← 28: 9.5 ← 29: 10.3x ↖ 30: 9.5 →		1: 9.8 ↖ 2: 9.7 ↗ 3: 10.1 ← 4: 9.5 ↗ 5: 10.1 ↗ 6: 9.7 → 7: 10.0 ← 8: 9.5 ↗ 9: 9.9 ← 10: 10.3x ←	Serie	96.7
Total		0.0		Serie	98.6
Total		0.0		Total	
	11: 9.4 ↗ 12: 10.3x → 13: 8.7 ↓ 14: 10.7x ↗ 15: 9.8 → 16: 10.3x ↗ 17: 10.7x ↗ 18: 10.2x ↖ 19: 9.9 ↑ 20: 10.3x ↓		21: 9.8 ↖ 22: 9.7 ↓ 23: 10.6x ↓ 24: 9.0 ← 25: 8.9 ↗ 26: 9.2 ↓ 27: 10.1 ← 28: 10.6x ↓ 29: 10.4x ↖ 30: 9.4 →	Serie	100.3
Total		198.9		Serie	97.7
Total		198.9		Total	
	31: 9.3 → 32: 10.2x ↗ 33: 10.8x ↗ 34: 9.8 ↓ 35: 10.2x ↓ 36: 10.3x → 37: 10.0 ↙ 38: 10.2x ↗ 39: 9.4 ↓ 40: 10.5x ↓		41: 10.3x ↓ 42: 10.2x ↗ 43: 10.3x ← 44: 9.2 → 45: 9.2 ← 46: 10.4x → 47: 10.4x ↓ 48: 10.7x ↗ 49: 8.8 ↓ 50: 10.9x ↗	Serie	100.7
Total		397.3		Serie	100.4
Total		397.3		Total	
	51: 8.9 ↓ 52: 9.0 ↓ 53: 8.7 → 54: 10.7x ← 55: 10.1 ↙ 56: 9.3 ↓ 57: 9.1 ↙ 58: 10.0 ↓ 59: 9.1 ← 60: 9.6 ↗			Serie	94.5
Total		592.2		Serie	94.5
Total		592.2		Total	

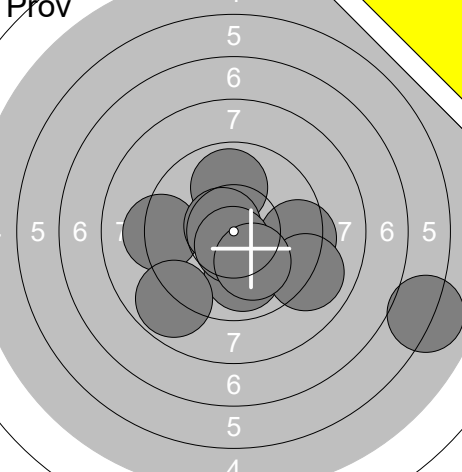
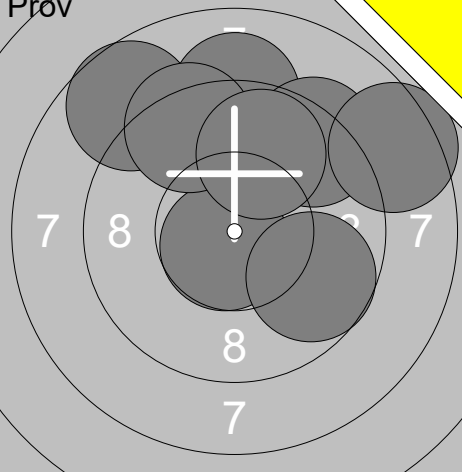
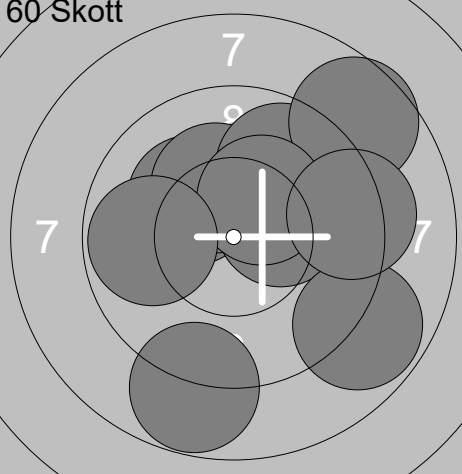
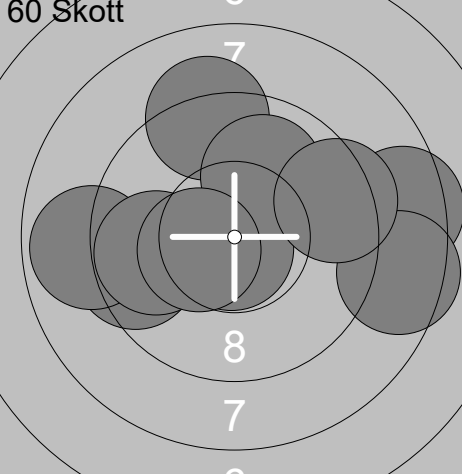
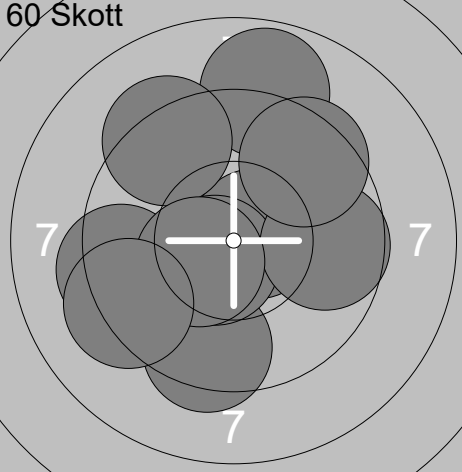
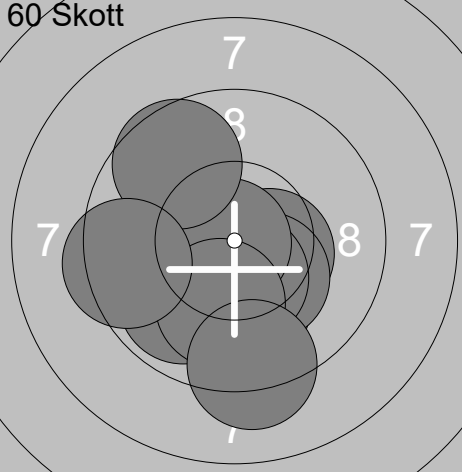
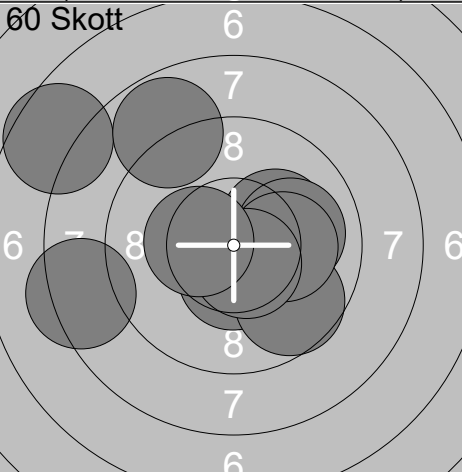
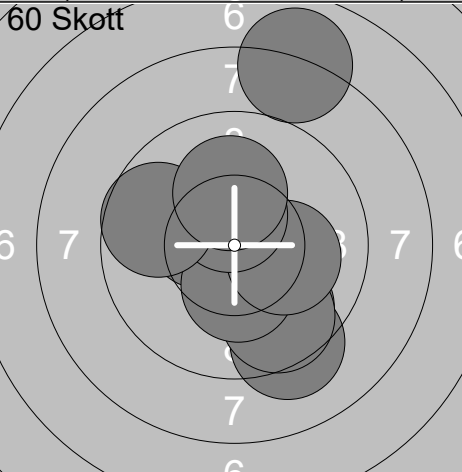
 <p style="text-align: center;">Proov</p>	<table border="1" style="width:100%; border-collapse: collapse;"> <tr><td>1:</td><td>9.3</td><td>←</td></tr> <tr><td>2:</td><td>9.9</td><td>↓</td></tr> <tr><td>3:</td><td>9.9</td><td>↑</td></tr> <tr><td>4:</td><td>8.8</td><td>↓</td></tr> <tr><td>5:</td><td>9.4</td><td>→</td></tr> <tr><td>6:</td><td>6.0</td><td>↓</td></tr> <tr><td>7:</td><td>10.7x</td><td>↗</td></tr> <tr><td>8:</td><td>10.6x</td><td>↓</td></tr> <tr><td>9:</td><td>9.0</td><td>↓</td></tr> <tr><td>10:</td><td>10.1</td><td>↓</td></tr> <tr><td colspan="2">Serie</td><td>93.7</td></tr> <tr><td colspan="2">Total</td><td>0.0</td></tr> </table>	1:	9.3	←	2:	9.9	↓	3:	9.9	↑	4:	8.8	↓	5:	9.4	→	6:	6.0	↓	7:	10.7x	↗	8:	10.6x	↓	9:	9.0	↓	10:	10.1	↓	Serie		93.7	Total		0.0	 <p style="text-align: center;">Proov</p>	<table border="1" style="width:100%; border-collapse: collapse;"> <tr><td>11:</td><td>8.7</td><td>↖</td></tr> <tr><td>12:</td><td>10.7x</td><td>↓</td></tr> <tr><td>13:</td><td>9.1</td><td>↑</td></tr> <tr><td>14:</td><td>9.3</td><td>↗</td></tr> <tr><td>15:</td><td>9.7</td><td>↘</td></tr> <tr><td>16:</td><td>8.5</td><td>↗</td></tr> <tr><td>17:</td><td>9.4</td><td>↑</td></tr> <tr><td>18:</td><td>9.8</td><td>↑</td></tr> <tr><td colspan="2">Serie</td><td>75.2</td></tr> <tr><td colspan="2">Total</td><td>0.0</td></tr> </table>	11:	8.7	↖	12:	10.7x	↓	13:	9.1	↑	14:	9.3	↗	15:	9.7	↘	16:	8.5	↗	17:	9.4	↑	18:	9.8	↑	Serie		75.2	Total		0.0						
1:	9.3	←																																																																									
2:	9.9	↓																																																																									
3:	9.9	↑																																																																									
4:	8.8	↓																																																																									
5:	9.4	→																																																																									
6:	6.0	↓																																																																									
7:	10.7x	↗																																																																									
8:	10.6x	↓																																																																									
9:	9.0	↓																																																																									
10:	10.1	↓																																																																									
Serie		93.7																																																																									
Total		0.0																																																																									
11:	8.7	↖																																																																									
12:	10.7x	↓																																																																									
13:	9.1	↑																																																																									
14:	9.3	↗																																																																									
15:	9.7	↘																																																																									
16:	8.5	↗																																																																									
17:	9.4	↑																																																																									
18:	9.8	↑																																																																									
Serie		75.2																																																																									
Total		0.0																																																																									
 <p style="text-align: center;">60 Skott</p>	<table border="1" style="width:100%; border-collapse: collapse;"> <tr><td>1:</td><td>10.2x</td><td>↗</td></tr> <tr><td>2:</td><td>10.3x</td><td>→</td></tr> <tr><td>3:</td><td>10.2x</td><td>↑</td></tr> <tr><td>4:</td><td>9.8</td><td>↗</td></tr> <tr><td>5:</td><td>8.8</td><td>↓</td></tr> <tr><td>6:</td><td>8.8</td><td>↓</td></tr> <tr><td>7:</td><td>8.6</td><td>↗</td></tr> <tr><td>8:</td><td>10.3x</td><td>↗</td></tr> <tr><td>9:</td><td>9.3</td><td>→</td></tr> <tr><td>10:</td><td>9.8</td><td>←</td></tr> <tr><td colspan="2">Serie</td><td>96.1</td></tr> <tr><td colspan="2">Total</td><td>96.1</td></tr> </table>	1:	10.2x	↗	2:	10.3x	→	3:	10.2x	↑	4:	9.8	↗	5:	8.8	↓	6:	8.8	↓	7:	8.6	↗	8:	10.3x	↗	9:	9.3	→	10:	9.8	←	Serie		96.1	Total		96.1	 <p style="text-align: center;">60 Skott</p>	<table border="1" style="width:100%; border-collapse: collapse;"> <tr><td>11:</td><td>10.8x</td><td>↓</td></tr> <tr><td>12:</td><td>9.4</td><td>←</td></tr> <tr><td>13:</td><td>8.9</td><td>←</td></tr> <tr><td>14:</td><td>9.2</td><td>↑</td></tr> <tr><td>15:</td><td>10.0</td><td>↑</td></tr> <tr><td>16:</td><td>8.5</td><td>→</td></tr> <tr><td>17:</td><td>8.5</td><td>→</td></tr> <tr><td>18:</td><td>9.8</td><td>←</td></tr> <tr><td>19:</td><td>9.4</td><td>→</td></tr> <tr><td>20:</td><td>10.4x</td><td>←</td></tr> <tr><td colspan="2">Serie</td><td>94.9</td></tr> <tr><td colspan="2">Total</td><td>191.0</td></tr> </table>	11:	10.8x	↓	12:	9.4	←	13:	8.9	←	14:	9.2	↑	15:	10.0	↑	16:	8.5	→	17:	8.5	→	18:	9.8	←	19:	9.4	→	20:	10.4x	←	Serie		94.9	Total		191.0
1:	10.2x	↗																																																																									
2:	10.3x	→																																																																									
3:	10.2x	↑																																																																									
4:	9.8	↗																																																																									
5:	8.8	↓																																																																									
6:	8.8	↓																																																																									
7:	8.6	↗																																																																									
8:	10.3x	↗																																																																									
9:	9.3	→																																																																									
10:	9.8	←																																																																									
Serie		96.1																																																																									
Total		96.1																																																																									
11:	10.8x	↓																																																																									
12:	9.4	←																																																																									
13:	8.9	←																																																																									
14:	9.2	↑																																																																									
15:	10.0	↑																																																																									
16:	8.5	→																																																																									
17:	8.5	→																																																																									
18:	9.8	←																																																																									
19:	9.4	→																																																																									
20:	10.4x	←																																																																									
Serie		94.9																																																																									
Total		191.0																																																																									
 <p style="text-align: center;">60 Skott</p>	<table border="1" style="width:100%; border-collapse: collapse;"> <tr><td>21:</td><td>9.3</td><td>←</td></tr> <tr><td>22:</td><td>9.4</td><td>↓</td></tr> <tr><td>23:</td><td>10.6x</td><td>→</td></tr> <tr><td>24:</td><td>10.6x</td><td>↖</td></tr> <tr><td>25:</td><td>9.7</td><td>→</td></tr> <tr><td>26:</td><td>8.9</td><td>↑</td></tr> <tr><td>27:</td><td>9.3</td><td>↗</td></tr> <tr><td>28:</td><td>9.5</td><td>↗</td></tr> <tr><td>29:</td><td>10.4x</td><td>↖</td></tr> <tr><td>30:</td><td>9.3</td><td>↖</td></tr> <tr><td colspan="2">Serie</td><td>97.0</td></tr> <tr><td colspan="2">Total</td><td>288.0</td></tr> </table>	21:	9.3	←	22:	9.4	↓	23:	10.6x	→	24:	10.6x	↖	25:	9.7	→	26:	8.9	↑	27:	9.3	↗	28:	9.5	↗	29:	10.4x	↖	30:	9.3	↖	Serie		97.0	Total		288.0	 <p style="text-align: center;">60 Skott</p>	<table border="1" style="width:100%; border-collapse: collapse;"> <tr><td>31:</td><td>10.4x</td><td>→</td></tr> <tr><td>32:</td><td>10.0</td><td>↓</td></tr> <tr><td>33:</td><td>10.3x</td><td>↓</td></tr> <tr><td>34:</td><td>10.4x</td><td>↓</td></tr> <tr><td>35:</td><td>9.9</td><td>↖</td></tr> <tr><td>36:</td><td>10.8x</td><td>←</td></tr> <tr><td>37:</td><td>10.1</td><td>↓</td></tr> <tr><td>38:</td><td>9.6</td><td>↗</td></tr> <tr><td>39:</td><td>9.4</td><td>←</td></tr> <tr><td>40:</td><td>9.2</td><td>↓</td></tr> <tr><td colspan="2">Serie</td><td>100.1</td></tr> <tr><td colspan="2">Total</td><td>388.1</td></tr> </table>	31:	10.4x	→	32:	10.0	↓	33:	10.3x	↓	34:	10.4x	↓	35:	9.9	↖	36:	10.8x	←	37:	10.1	↓	38:	9.6	↗	39:	9.4	←	40:	9.2	↓	Serie		100.1	Total		388.1
21:	9.3	←																																																																									
22:	9.4	↓																																																																									
23:	10.6x	→																																																																									
24:	10.6x	↖																																																																									
25:	9.7	→																																																																									
26:	8.9	↑																																																																									
27:	9.3	↗																																																																									
28:	9.5	↗																																																																									
29:	10.4x	↖																																																																									
30:	9.3	↖																																																																									
Serie		97.0																																																																									
Total		288.0																																																																									
31:	10.4x	→																																																																									
32:	10.0	↓																																																																									
33:	10.3x	↓																																																																									
34:	10.4x	↓																																																																									
35:	9.9	↖																																																																									
36:	10.8x	←																																																																									
37:	10.1	↓																																																																									
38:	9.6	↗																																																																									
39:	9.4	←																																																																									
40:	9.2	↓																																																																									
Serie		100.1																																																																									
Total		388.1																																																																									
 <p style="text-align: center;">60 Skott</p>	<table border="1" style="width:100%; border-collapse: collapse;"> <tr><td>41:</td><td>10.5x</td><td>↓</td></tr> <tr><td>42:</td><td>10.2x</td><td>↗</td></tr> <tr><td>43:</td><td>9.7</td><td>↓</td></tr> <tr><td>44:</td><td>10.0</td><td>→</td></tr> <tr><td>45:</td><td>8.3</td><td>←</td></tr> <tr><td>46:</td><td>7.6</td><td>↗</td></tr> <tr><td>47:</td><td>8.8</td><td>↗</td></tr> <tr><td>48:</td><td>10.1</td><td>→</td></tr> <tr><td>49:</td><td>10.6x</td><td>↓</td></tr> <tr><td>50:</td><td>10.4x</td><td>←</td></tr> <tr><td colspan="2">Serie</td><td>96.2</td></tr> <tr><td colspan="2">Total</td><td>484.3</td></tr> </table>	41:	10.5x	↓	42:	10.2x	↗	43:	9.7	↓	44:	10.0	→	45:	8.3	←	46:	7.6	↗	47:	8.8	↗	48:	10.1	→	49:	10.6x	↓	50:	10.4x	←	Serie		96.2	Total		484.3	 <p style="text-align: center;">60 Skott</p>	<table border="1" style="width:100%; border-collapse: collapse;"> <tr><td>51:</td><td>9.8</td><td>↓</td></tr> <tr><td>52:</td><td>9.2</td><td>↓</td></tr> <tr><td>53:</td><td>10.4x</td><td>↖</td></tr> <tr><td>54:</td><td>9.7</td><td>↓</td></tr> <tr><td>55:</td><td>10.3x</td><td>↓</td></tr> <tr><td>56:</td><td>8.0</td><td>↑</td></tr> <tr><td>57:</td><td>10.2x</td><td>→</td></tr> <tr><td>58:</td><td>10.5x</td><td>↑</td></tr> <tr><td>59:</td><td>9.7</td><td>←</td></tr> <tr><td>60:</td><td>10.1</td><td>↑</td></tr> <tr><td colspan="2">Serie</td><td>97.9</td></tr> <tr><td colspan="2">Total</td><td>582.2</td></tr> </table>	51:	9.8	↓	52:	9.2	↓	53:	10.4x	↖	54:	9.7	↓	55:	10.3x	↓	56:	8.0	↑	57:	10.2x	→	58:	10.5x	↑	59:	9.7	←	60:	10.1	↑	Serie		97.9	Total		582.2
41:	10.5x	↓																																																																									
42:	10.2x	↗																																																																									
43:	9.7	↓																																																																									
44:	10.0	→																																																																									
45:	8.3	←																																																																									
46:	7.6	↗																																																																									
47:	8.8	↗																																																																									
48:	10.1	→																																																																									
49:	10.6x	↓																																																																									
50:	10.4x	←																																																																									
Serie		96.2																																																																									
Total		484.3																																																																									
51:	9.8	↓																																																																									
52:	9.2	↓																																																																									
53:	10.4x	↖																																																																									
54:	9.7	↓																																																																									
55:	10.3x	↓																																																																									
56:	8.0	↑																																																																									
57:	10.2x	→																																																																									
58:	10.5x	↑																																																																									
59:	9.7	←																																																																									
60:	10.1	↑																																																																									
Serie		97.9																																																																									
Total		582.2																																																																									

Skjutlag	Tavla	Maja Wadman			
3	3	Ramselefors	Hållnäs	13S	Up
04.11.2018	Vindelnskyttet 2018	Ramselefors SKF			
Prov 	1: 9.4 ↗ 2: 8.0 → 3: 9.1 ↗ 4: 10.0 ↖ 5: 9.5 → 6: 9.0 ← 7: 9.7 ↗ 8: 9.4 ↖ 9: 9.2 → 10: 9.5 →	Prov 	11: 10.2x ↗ 12: 8.5 → 13: 9.9 ↘ 14: 10.8x ↖ 15: 8.4 ↘ 16: 10.4x ↘ 17: 9.8 ↑ 18: 9.6 → 19: 8.5 → 20: 9.3 ↗		
	Serie 92.8		Serie 95.4		
	Total 0.0		Total 0.0		
60 Skott 	1: 8.0 ↘ 2: 9.3 ↘ 3: 9.7 → 4: 9.6 ↘ 5: 8.7 ↗ 6: 8.9 ↗ 7: 9.0 ↗ 8: 9.2 ↗ 9: 9.6 → 10: 9.3 →	60 Skott 	11: 10.9x ↗ 12: 9.1 ↘ 13: 8.9 ↘ 14: 10.7x → 15: 10.0 ↘ 16: 8.8 ← 17: 9.4 → 18: 9.1 ↘ 19: 10.6x ↘ 20: 9.6 ↑		
	Serie 91.3		Serie 97.1		
	Total 91.3		Total 188.4		
60 Skott 	21: 10.8x ↘ 22: 9.3 ← 23: 10.4x ↗ 24: 9.1 ↗ 25: 10.2x → 26: 9.4 ← 27: 10.4x ↘ 28: 10.0 ↘ 29: 7.5 ↗ 30: 10.1 →	60 Skott 	31: 9.8 → 32: 9.7 ↗ 33: 10.2x ↘ 34: 10.5x ↗ 35: 8.1 → 36: 10.0 → 37: 10.6x ↗ 38: 9.8 ↘ 39: 8.9 → 40: 8.7 →		
	Serie 97.2		Serie 96.3		
	Total 285.6		Total 381.9		
60 Skott 	41: 9.5 ↘ 42: 9.5 → 43: 10.3x ↗ 44: 10.3x ← 45: 9.7 → 46: 9.8 → 47: 9.0 → 48: 10.1 ↘ 49: 7.7 ↘ 50: 9.9 →	60 Skott 	51: 10.6x ← 52: 10.6x ↘ 53: 10.3x ↘ 54: 9.2 ↖ 55: 8.2 ↖ 56: 9.9 ↘ 57: 9.7 ↘ 58: 10.2x ↖ 59: 9.1 ← 60: 9.3 ↘		
	Serie 95.8		Serie 97.1		
	Total 477.7		Total 574.8		

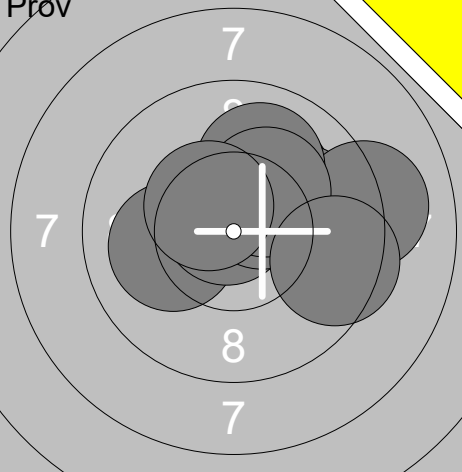
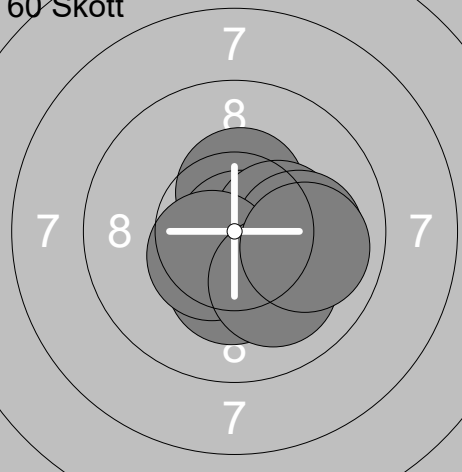
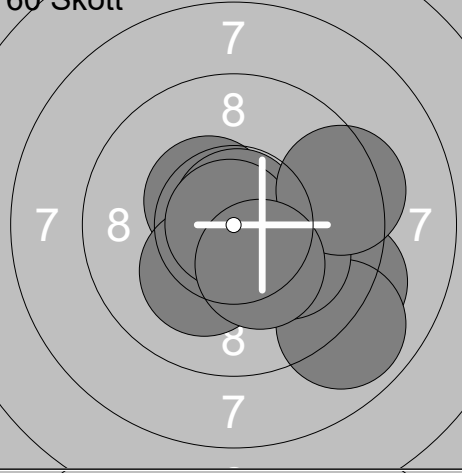
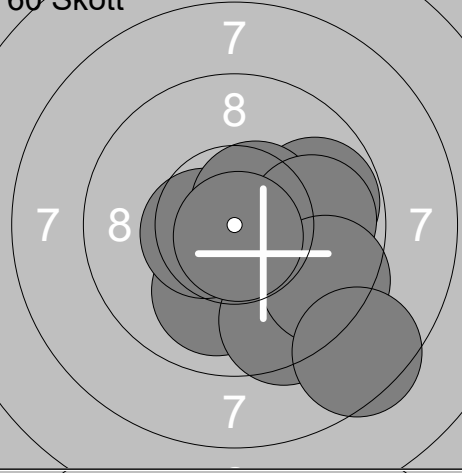
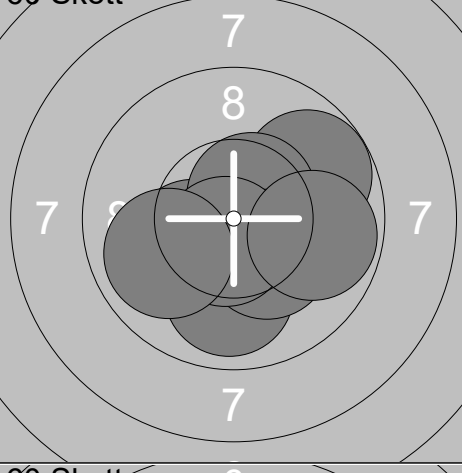
Prov 	<table style="width:100%; border-collapse: collapse;"> <tr><td>1:</td><td>10.1</td><td>↗</td></tr> <tr><td>2:</td><td>10.1</td><td>←</td></tr> <tr><td>3:</td><td>10.0</td><td>→</td></tr> <tr><td>4:</td><td>9.1</td><td>→</td></tr> <tr><td>5:</td><td>10.0</td><td>↗</td></tr> <tr><td>6:</td><td>10.8x</td><td>↗</td></tr> <tr><td>7:</td><td>10.4x</td><td>↗</td></tr> <tr><td>8:</td><td>10.2x</td><td>↗</td></tr> <tr><td>9:</td><td>10.5x</td><td>↗</td></tr> <tr><td>10:</td><td>9.5</td><td>↘</td></tr> <tr><td colspan="2">Serie</td><td>100.7</td></tr> <tr><td colspan="2">Total</td><td>0.0</td></tr> </table>	1:	10.1	↗	2:	10.1	←	3:	10.0	→	4:	9.1	→	5:	10.0	↗	6:	10.8x	↗	7:	10.4x	↗	8:	10.2x	↗	9:	10.5x	↗	10:	9.5	↘	Serie		100.7	Total		0.0	60 Skott  <table style="width:100%; border-collapse: collapse;"> <tr><td>11:</td><td>10.3x</td><td>↘</td></tr> <tr><td>12:</td><td>9.2</td><td>↘</td></tr> <tr><td>13:</td><td>10.5x</td><td>↗</td></tr> <tr><td>14:</td><td>10.2x</td><td>↘</td></tr> <tr><td>15:</td><td>10.8x</td><td>↗</td></tr> <tr><td>16:</td><td>8.9</td><td>↘</td></tr> <tr><td>17:</td><td>10.1</td><td>↘</td></tr> <tr><td>18:</td><td>10.9x</td><td>←</td></tr> <tr><td>19:</td><td>9.4</td><td>→</td></tr> <tr><td>20:</td><td>10.3x</td><td>↘</td></tr> <tr><td colspan="2">Serie</td><td>100.6</td></tr> <tr><td colspan="2">Total</td><td>203.7</td></tr> </table>	11:	10.3x	↘	12:	9.2	↘	13:	10.5x	↗	14:	10.2x	↘	15:	10.8x	↗	16:	8.9	↘	17:	10.1	↘	18:	10.9x	←	19:	9.4	→	20:	10.3x	↘	Serie		100.6	Total		203.7	<table style="width:100%; border-collapse: collapse;"> <tr><td>1:</td><td>10.3x</td><td>↘</td></tr> <tr><td>2:</td><td>10.4x</td><td>↑</td></tr> <tr><td>3:</td><td>10.8x</td><td>↘</td></tr> <tr><td>4:</td><td>10.3x</td><td>→</td></tr> <tr><td>5:</td><td>10.4x</td><td>↘</td></tr> <tr><td>6:</td><td>10.3x</td><td>↘</td></tr> <tr><td>7:</td><td>10.1</td><td>→</td></tr> <tr><td>8:</td><td>10.5x</td><td>↖</td></tr> <tr><td>9:</td><td>10.1</td><td>↘</td></tr> <tr><td>10:</td><td>9.9</td><td>→</td></tr> <tr><td colspan="2">Serie</td><td>103.1</td></tr> <tr><td colspan="2">Total</td><td>103.1</td></tr> </table>	1:	10.3x	↘	2:	10.4x	↑	3:	10.8x	↘	4:	10.3x	→	5:	10.4x	↘	6:	10.3x	↘	7:	10.1	→	8:	10.5x	↖	9:	10.1	↘	10:	9.9	→	Serie		103.1	Total		103.1
1:	10.1	↗																																																																																																													
2:	10.1	←																																																																																																													
3:	10.0	→																																																																																																													
4:	9.1	→																																																																																																													
5:	10.0	↗																																																																																																													
6:	10.8x	↗																																																																																																													
7:	10.4x	↗																																																																																																													
8:	10.2x	↗																																																																																																													
9:	10.5x	↗																																																																																																													
10:	9.5	↘																																																																																																													
Serie		100.7																																																																																																													
Total		0.0																																																																																																													
11:	10.3x	↘																																																																																																													
12:	9.2	↘																																																																																																													
13:	10.5x	↗																																																																																																													
14:	10.2x	↘																																																																																																													
15:	10.8x	↗																																																																																																													
16:	8.9	↘																																																																																																													
17:	10.1	↘																																																																																																													
18:	10.9x	←																																																																																																													
19:	9.4	→																																																																																																													
20:	10.3x	↘																																																																																																													
Serie		100.6																																																																																																													
Total		203.7																																																																																																													
1:	10.3x	↘																																																																																																													
2:	10.4x	↑																																																																																																													
3:	10.8x	↘																																																																																																													
4:	10.3x	→																																																																																																													
5:	10.4x	↘																																																																																																													
6:	10.3x	↘																																																																																																													
7:	10.1	→																																																																																																													
8:	10.5x	↖																																																																																																													
9:	10.1	↘																																																																																																													
10:	9.9	→																																																																																																													
Serie		103.1																																																																																																													
Total		103.1																																																																																																													
60 Skott 	<table style="width:100%; border-collapse: collapse;"> <tr><td>31:</td><td>10.5x</td><td>↘</td></tr> <tr><td>32:</td><td>9.8</td><td>↗</td></tr> <tr><td>33:</td><td>10.4x</td><td>↘</td></tr> <tr><td>34:</td><td>10.3x</td><td>←</td></tr> <tr><td>35:</td><td>9.9</td><td>↘</td></tr> <tr><td>36:</td><td>10.6x</td><td>↗</td></tr> <tr><td>37:</td><td>10.3x</td><td>↘</td></tr> <tr><td>38:</td><td>10.6x</td><td>↘</td></tr> <tr><td>39:</td><td>9.8</td><td>→</td></tr> <tr><td>40:</td><td>9.9</td><td>↖</td></tr> <tr><td colspan="2">Serie</td><td>102.1</td></tr> <tr><td colspan="2">Total</td><td>405.5</td></tr> </table>	31:	10.5x	↘	32:	9.8	↗	33:	10.4x	↘	34:	10.3x	←	35:	9.9	↘	36:	10.6x	↗	37:	10.3x	↘	38:	10.6x	↘	39:	9.8	→	40:	9.9	↖	Serie		102.1	Total		405.5	60 Skott  <table style="width:100%; border-collapse: collapse;"> <tr><td>21:</td><td>10.6x</td><td>↘</td></tr> <tr><td>22:</td><td>10.0</td><td>↘</td></tr> <tr><td>23:</td><td>10.5x</td><td>←</td></tr> <tr><td>24:</td><td>9.8</td><td>→</td></tr> <tr><td>25:</td><td>9.5</td><td>↘</td></tr> <tr><td>26:</td><td>10.6x</td><td>↗</td></tr> <tr><td>27:</td><td>9.9</td><td>→</td></tr> <tr><td>28:</td><td>9.5</td><td>↘</td></tr> <tr><td>29:</td><td>8.5</td><td>↘</td></tr> <tr><td>30:</td><td>10.8x</td><td>↘</td></tr> <tr><td colspan="2">Serie</td><td>99.7</td></tr> <tr><td colspan="2">Total</td><td>303.4</td></tr> </table>	21:	10.6x	↘	22:	10.0	↘	23:	10.5x	←	24:	9.8	→	25:	9.5	↘	26:	10.6x	↗	27:	9.9	→	28:	9.5	↘	29:	8.5	↘	30:	10.8x	↘	Serie		99.7	Total		303.4	<table style="width:100%; border-collapse: collapse;"> <tr><td>41:</td><td>10.3x</td><td>↘</td></tr> <tr><td>42:</td><td>10.6x</td><td>←</td></tr> <tr><td>43:</td><td>10.3x</td><td>↗</td></tr> <tr><td>44:</td><td>10.5x</td><td>↘</td></tr> <tr><td>45:</td><td>9.3</td><td>↖</td></tr> <tr><td>46:</td><td>9.8</td><td>←</td></tr> <tr><td>47:</td><td>10.1</td><td>↘</td></tr> <tr><td>48:</td><td>9.7</td><td>↘</td></tr> <tr><td>49:</td><td>10.6x</td><td>↘</td></tr> <tr><td>50:</td><td>10.1</td><td>↗</td></tr> <tr><td colspan="2">Serie</td><td>101.3</td></tr> <tr><td colspan="2">Total</td><td>506.8</td></tr> </table>	41:	10.3x	↘	42:	10.6x	←	43:	10.3x	↗	44:	10.5x	↘	45:	9.3	↖	46:	9.8	←	47:	10.1	↘	48:	9.7	↘	49:	10.6x	↘	50:	10.1	↗	Serie		101.3	Total		506.8
31:	10.5x	↘																																																																																																													
32:	9.8	↗																																																																																																													
33:	10.4x	↘																																																																																																													
34:	10.3x	←																																																																																																													
35:	9.9	↘																																																																																																													
36:	10.6x	↗																																																																																																													
37:	10.3x	↘																																																																																																													
38:	10.6x	↘																																																																																																													
39:	9.8	→																																																																																																													
40:	9.9	↖																																																																																																													
Serie		102.1																																																																																																													
Total		405.5																																																																																																													
21:	10.6x	↘																																																																																																													
22:	10.0	↘																																																																																																													
23:	10.5x	←																																																																																																													
24:	9.8	→																																																																																																													
25:	9.5	↘																																																																																																													
26:	10.6x	↗																																																																																																													
27:	9.9	→																																																																																																													
28:	9.5	↘																																																																																																													
29:	8.5	↘																																																																																																													
30:	10.8x	↘																																																																																																													
Serie		99.7																																																																																																													
Total		303.4																																																																																																													
41:	10.3x	↘																																																																																																													
42:	10.6x	←																																																																																																													
43:	10.3x	↗																																																																																																													
44:	10.5x	↘																																																																																																													
45:	9.3	↖																																																																																																													
46:	9.8	←																																																																																																													
47:	10.1	↘																																																																																																													
48:	9.7	↘																																																																																																													
49:	10.6x	↘																																																																																																													
50:	10.1	↗																																																																																																													
Serie		101.3																																																																																																													
Total		506.8																																																																																																													
60 Skott 	<table style="width:100%; border-collapse: collapse;"> <tr><td>51:</td><td>9.9</td><td>←</td></tr> <tr><td>52:</td><td>10.0</td><td>↘</td></tr> <tr><td>53:</td><td>10.2x</td><td>↘</td></tr> <tr><td>54:</td><td>8.1</td><td>→</td></tr> <tr><td>55:</td><td>9.8</td><td>↘</td></tr> <tr><td>56:</td><td>9.6</td><td>←</td></tr> <tr><td>57:</td><td>10.2x</td><td>↘</td></tr> <tr><td>58:</td><td>10.5x</td><td>↖</td></tr> <tr><td>59:</td><td>9.8</td><td>↘</td></tr> <tr><td>60:</td><td>10.7x</td><td>←</td></tr> <tr><td colspan="2">Serie</td><td>98.8</td></tr> <tr><td colspan="2">Total</td><td>605.6</td></tr> </table>	51:	9.9	←	52:	10.0	↘	53:	10.2x	↘	54:	8.1	→	55:	9.8	↘	56:	9.6	←	57:	10.2x	↘	58:	10.5x	↖	59:	9.8	↘	60:	10.7x	←	Serie		98.8	Total		605.6																																																																										
51:	9.9	←																																																																																																													
52:	10.0	↘																																																																																																													
53:	10.2x	↘																																																																																																													
54:	8.1	→																																																																																																													
55:	9.8	↘																																																																																																													
56:	9.6	←																																																																																																													
57:	10.2x	↘																																																																																																													
58:	10.5x	↖																																																																																																													
59:	9.8	↘																																																																																																													
60:	10.7x	←																																																																																																													
Serie		98.8																																																																																																													
Total		605.6																																																																																																													

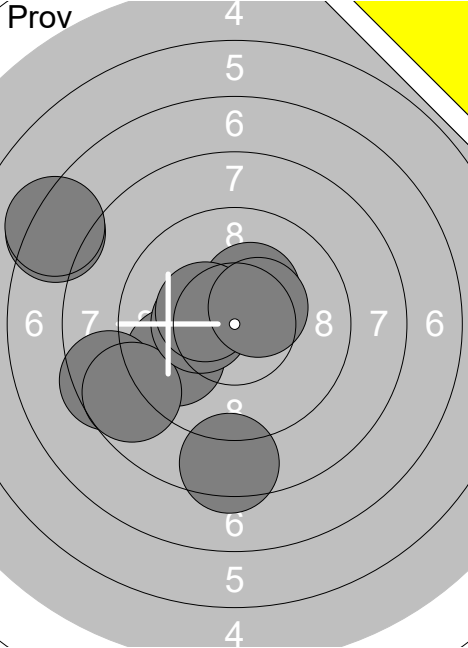
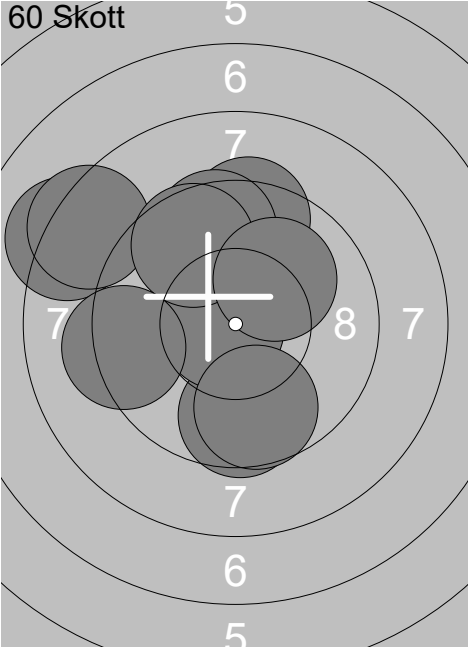
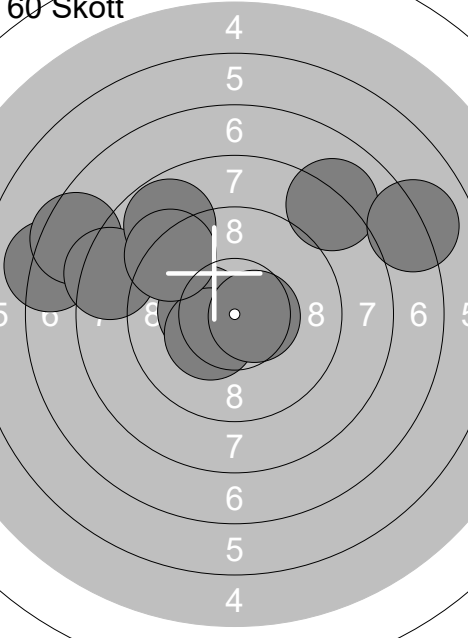
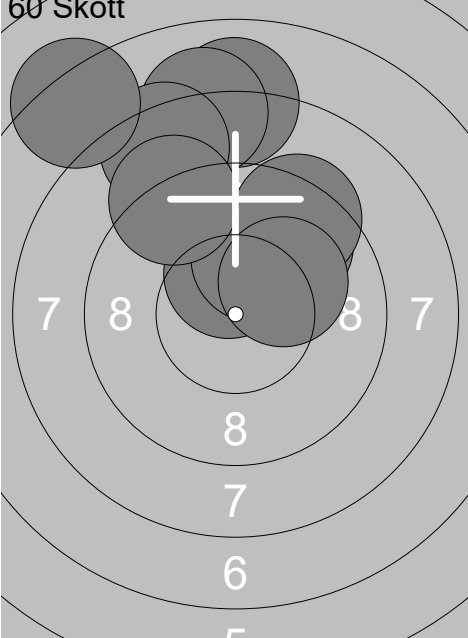
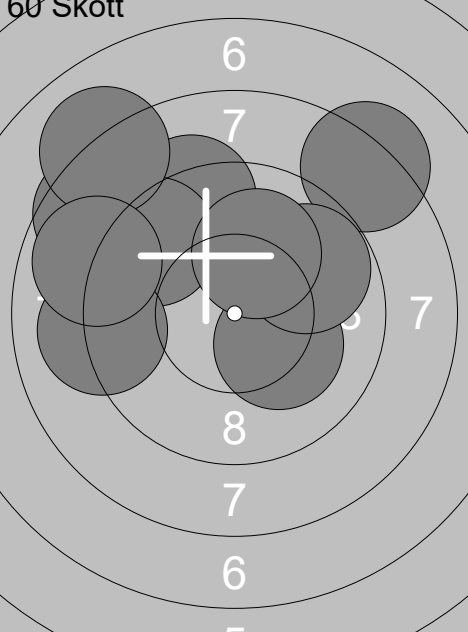

Skjuttag	Tavla	Jennifer Gustafsson			
3	6	Ramselefors	Ramselefors	13S	Vb
04.11.2018	Vindelnskyttet 2018	Ramselefors SKF			
Prov		1: 9.3 ← 2: 9.4 ↗ 3: 8.5 ↗ 4: 8.7 → 5: 8.4 → 6: 7.2 → 7: 9.0 → 8: 8.4 ↗ 9: 9.9 ↑ 10: 9.2 ↓	Prov		11: 9.9 ↑ 12: 9.2 ↗ 13: 7.6 →
	Serie 88.0 Total 0.0			Serie 26.7 Total 0.0	
60 Skott		1: 9.2 ↖ 2: 8.9 ↑ 3: 10.2x ↖ 4: 9.5 ← 5: 8.9 ↗ 6: 7.6 ↗ 7: 10.6x ↓ 8: 8.2 ← 9: 8.7 ↗ 10: 8.3 →	60 Skott		11: 9.7 ↑ 12: 9.6 ↓ 13: 8.8 ↑ 14: 9.1 ↑ 15: 10.2x ↗ 16: 7.7 ↑ 17: 8.0 → 18: 9.2 ↖ 19: 8.6 ↖ 20: 10.1 ↓
	Serie 90.1 Total 90.1			Serie 91.0 Total 181.1	
60 Skott		21: 9.7 ↑ 22: 8.9 ↗ 23: 9.0 ↑ 24: 10.4x ↗ 25: 9.7 ↑ 26: 8.4 → 27: 9.6 ↗ 28: 9.0 ↑ 29: 9.5 ↗ 30: 10.7x ↓	60 Skott		31: 7.6 → 32: 9.9 ↗ 33: 9.9 → 34: 9.5 ↑ 35: 8.7 ↑ 36: 9.1 ← 37: 8.4 → 38: 9.8 ↙ 39: 8.2 ↑ 40: 9.4 →
	Serie 94.9 Total 276.0			Serie 90.5 Total 366.5	
60 Skott		41: 9.3 → 42: 8.8 → 43: 5.2 ↗ 44: 9.5 ↑ 45: 9.0 ↑ 46: 9.5 ← 47: 9.2 ↗ 48: 9.2 ← 49: 10.4x ↓ 50: 7.9 →	60 Skott		51: 9.3 ↗ 52: 10.0 → 53: 10.0 ↑ 54: 6.8 → 55: 9.3 ↑ 56: 9.2 ↓ 57: 10.8x ← 58: 7.0 → 59: 10.1 ↓ 60: 9.4 ↑
	Serie 88.0 Total 454.5			Serie 91.9 Total 546.4	

Skjutlag 3	Tavla 7	Nadja Kurkkio	
Ramselefors	Gällivare	13S	No
04.11.2018	Vindelnskyttet 2018	Ramselefors SKF	
Prov		60 Skott	
	1: 10.3x ↗ 2: 8.5 ↓ 3: 7.3 ↖ 4: 9.7 ↖ 5: 8.5 ↖ 6: 8.7 ↖ 7: 10.3x↖ 8: 10.4x↖ 9: 10.4x↗ 10: 7.3 ↖		1: 9.6 ↓ 2: 10.7x↖ 3: 9.4 ↑ 4: 8.2 ↖ 5: 8.4 ↖ 6: 9.6 ↑ 7: 9.6 ↗ 8: 10.1 ↗ 9: 9.3 ↖ 10: 9.7 ↓
	Serie 91.4		Serie 94.6
	Total 0.0		Total 94.6
60 Skott		60 Skott	
	11: 8.1 ↗ 12: 10.3x↖ 13: 7.2 ↖ 14: 7.5 ↖ 15: 8.4 ↖ 16: 10.3x↖ 17: 10.6x→ 18: 7.1 ↗ 19: 8.8 ↗ 20: 9.2 ↖		21: 8.0 ↑ 22: 10.4x↑ 23: 9.7 ↗ 24: 8.1 ↑ 25: 10.1 ↑ 26: 8.4 ↑ 27: 7.3 ↖ 28: 9.4 ↗ 29: 10.1 ↗ 30: 9.1 ↖
	Serie 87.5		Serie 90.6
	Total 182.1		Total 272.7
60 Skott			
	31: 8.6 ↖ 32: 9.3 ↑ 33: 10.2x↘ 34: 8.2 ↗ 35: 9.4 ↖ 36: 9.1 ↖ 37: 8.1 ↗ 38: 9.8 ↗ 39: 8.9 ↖ 40: 10.1 ↑		
	Serie 91.7		
	Total 364.4		

Skjutlag	Tavla	Hanna Johansson		
3	8	Ramselefors	Vännäs	15S Vb
04.11.2018	Vindelnskyttet 2018	Ramselefors SKF		
Prov 	1: 10.2x ↑	Prov 	11: 10.1 ←	
	2: 9.1 →		12: 9.3 ↑	
	3: 10.3x ↙			
	4: 9.7 →			
	5: 9.2 →			
	6: 10.7x ↗			
	7: 9.8 ↓			
	8: 9.2 ↓			
	9: 9.1 →			
	10: 10.6x ↓			
	Serie 97.9		Serie 19.4	
	Total 0.0		Total 0.0	
60 Skott 	1: 10.7x ↙	60 Skott 	11: 10.4x ↓	
	2: 9.5 ↓		12: 9.4 ↓	
	3: 10.6x ↓		13: 9.5 ↓	
	4: 9.3 ↓		14: 9.2 ↑	
	5: 10.6x ↑		15: 10.0 ←	
	6: 9.9 ↗		16: 9.9 ←	
	7: 10.5x ↓		17: 9.9 →	
	8: 9.0 ↓		18: 10.6x ↗	
	9: 9.5 ↓		19: 10.1 ↓	
	10: 9.4 ↗		20: 10.8x ↓	
	Serie 99.0		Serie 99.8	
	Total 99.0		Total 198.8	
60 Skott 	21: 10.4x →	60 Skott 	31: 9.9 ↑	
	22: 9.8 ↑		32: 10.1 ↑	
	23: 10.1 ↓		33: 9.2 ↑	
	24: 10.1 ↑		34: 9.9 ↗	
	25: 10.0 →		35: 8.8 ←	
	26: 9.3 ←		36: 9.8 ←	
	27: 9.2 ↗		37: 10.0 ←	
	28: 10.0 ↓		38: 10.8x ↓	
	29: 9.3 →		39: 10.6x ↓	
	30: 9.1 →		40: 9.8 ←	
	Serie 97.3		Serie 98.9	
	Total 296.1		Total 395.0	

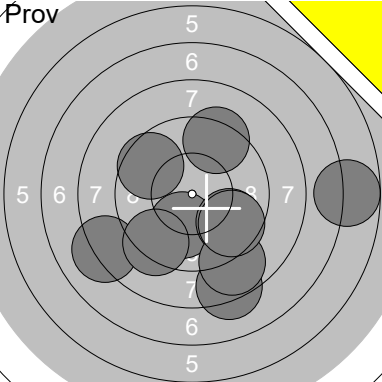

Skjutlag	Tavla	Julia Johansson		
3	9	Ramselefors	Hållnäs	17S Up
04.11.2018	Vindelnskyttet 2018	Ramselefors SKF		
Prov 	1: 10.2x ↑ 2: 10.2x ← 3: 9.3 → 4: 9.4 ↑ 5: 10.6x ↑ 6: 10.0 ↑ 7: 10.2x ↖ 8: 10.0 ↖ 9: 10.6x ↑ 10: 10.5x ↗	Prov 	11: 10.6x →	
Serie 101.0	Total 0.0	Serie 10.6	Total 0.0	
60 Skott 	1: 10.1 ↓ 2: 10.6x ↓ 3: 10.7x ↗ 4: 10.6x → 5: 10.1 ↓ 6: 9.9 → 7: 10.6x ↑ 8: 9.8 → 9: 10.6x ↗ 10: 9.9 ↗	60 Skott 	11: 10.1 ↗ 12: 10.7x ↑ 13: 8.7 ↑ 14: 10.8x ↖ 15: 10.3x ↑ 16: 10.1 ← 17: 9.2 ← 18: 10.4x ↖ 19: 10.5x ↑ 20: 10.9x ↗	
Serie 102.9	Total 102.9	Serie 101.7	Total 204.6	
60 Skott 	21: 10.0 → 22: 9.5 → 23: 10.4x → 24: 10.3x ← 25: 9.9 ↖ 26: 9.4 ← 27: 9.8 ← 28: 10.6x ↘ 29: 10.1 ↗ 30: 10.2x ↗	60 Skott 	31: 9.8 ↗ 32: 10.5x → 33: 8.8 ↖ 34: 10.6x ↖ 35: 9.7 ← 36: 9.2 ← 37: 9.7 ↑ 38: 9.3 → 39: 10.0 ↑ 40: 9.4 →	
Serie 100.2	Total 304.8	Serie 97.0	Total 401.8	
60 Skott 	41: 10.8x ↖ 42: 10.6x ↖ 43: 9.8 ↗ 44: 10.2x ↘ 45: 10.2x ↗ 46: 10.1 ↗ 47: 10.3x ↘ 48: 9.3 ← 49: 9.7 → 50: 9.5 ←	60 Skott 	51: 10.2x ↖ 52: 9.7 ↗ 53: 10.1 → 54: 10.3x ↑ 55: 10.4x ↘ 56: 10.4x ← 57: 10.0 ↗ 58: 9.9 ↖ 59: 10.0 ↘ 60: 10.1 →	
Serie 100.5	Total 502.3	Serie 101.1	Total 603.4	

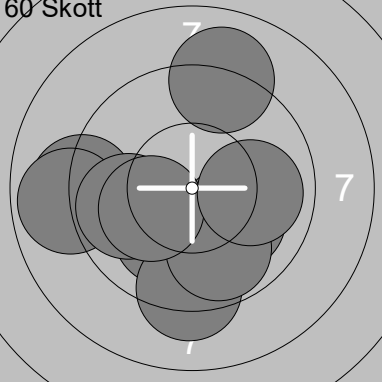
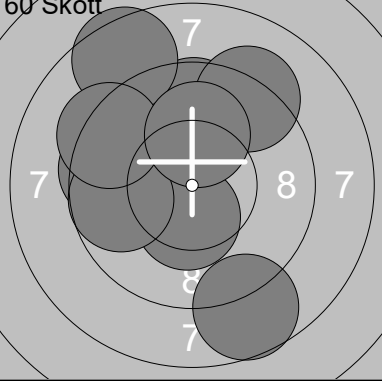
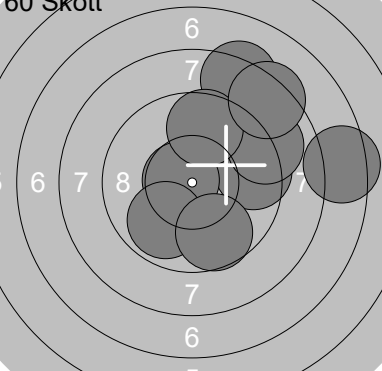
Skjuttag	Tavla	Erika Bergqvist	
3	10	Ramselefors	Umeå
04.11.2018	Vindelnskyttet 2018	15S	Vb
04.11.2018	Vindelnskyttet 2018	Ramselefors SKF	
Prov 	1: 8.9 ← 2: 10.7x → 3: 10.5x ↗ 4: 10.1 ↑ 5: 10.4x ← 6: 10.5x ↗ 7: 10.6x ↗ 8: 10.8x ↗ 9: 10.1 → 10: 9.6 ↑ Serie 102.2 Total 0.0	Prov 	11: 10.1 ↓ 12: 10.3x → 13: 9.4 → 14: 10.3x ↑ 15: 9.6 → Serie 49.7 Total 0.0
60 Skott 	1: 10.8x ↗ 2: 9.1 → 3: 8.1 → 4: 10.1 ↑ 5: 10.8x ↑ 6: 10.0 → 7: 10.5x → 8: 10.2x ↗ 9: 9.4 ← 10: 10.3x → Serie 99.3 Total 99.3	60 Skott 	11: 10.1 ↓ 12: 9.5 ↗ 13: 9.4 ↓ 14: 9.1 → 15: 10.4x ↓ 16: 10.1 ↗ 17: 10.3x ↓ 18: 10.6x → 19: 10.1 → 20: 10.0 ↗ Serie 99.6 Total 198.9
60 Skott 	21: 10.9x ↑ 22: 10.6x ↓ 23: 10.3x ↓ 24: 10.8x ↓ 25: 10.3x ↗ 26: 10.3x ↗ 27: 9.6 ↑ 28: 10.3x → 29: 10.4x ↗ 30: 9.8 ↑ Serie 103.3 Total 302.2	60 Skott 	31: 9.7 ↗ 32: 9.5 ← 33: 9.8 ↗ 34: 9.7 ↓ 35: 9.9 ↗ 36: 10.4x ← 37: 10.1 ↗ 38: 10.4x ↗ 39: 10.0 → 40: 10.2x → Serie 99.7 Total 401.9
60 Skott 	41: 10.3x ↑ 42: 9.3 ↑ 43: 10.4x ↑ 44: 10.5x ↑ 45: 9.9 ↗ 46: 10.1 ← 47: 10.4x ↗ 48: 10.5x ↗ 49: 9.3 ↑ 50: 10.2x ↗ Serie 100.9 Total 502.8	60 Skott 	51: 10.3x ↓ 52: 10.1 ↗ 53: 10.5x → 54: 9.9 ↗ 55: 8.9 → 56: 10.3x → 57: 10.4x ← 58: 10.4x ↓ 59: 10.4x ↓ 60: 10.0 ↓ Serie 101.2 Total 604.0

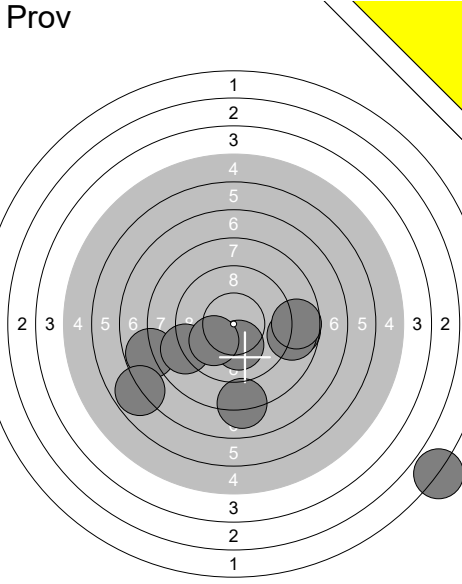
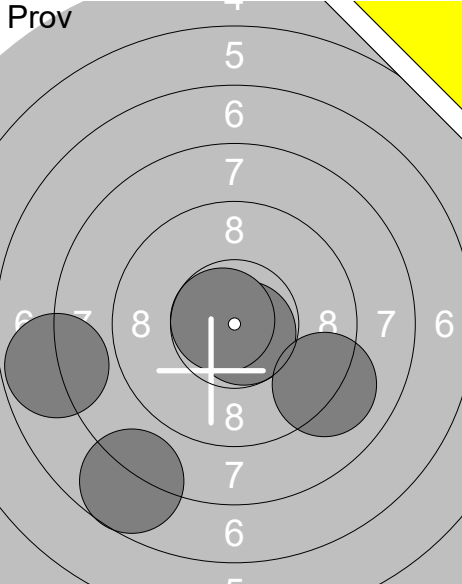
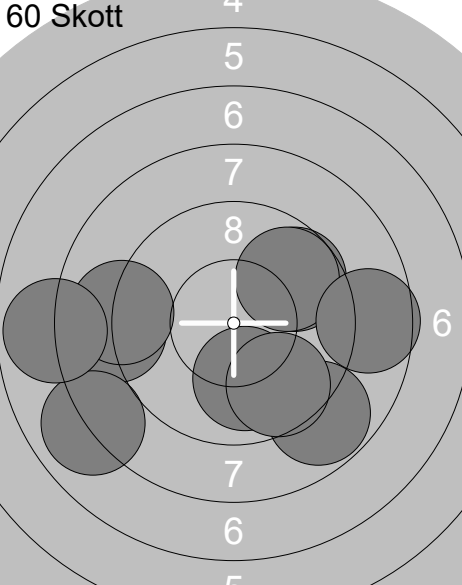
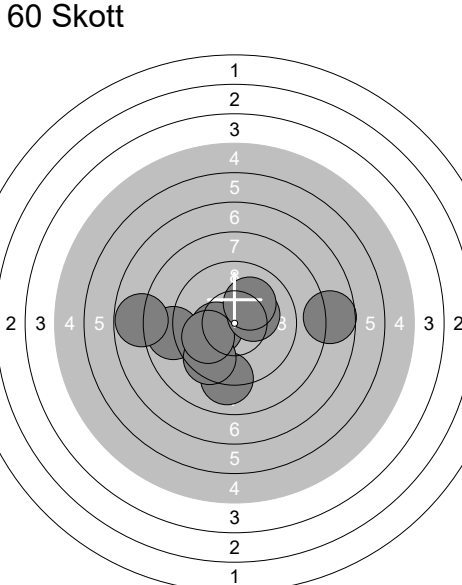
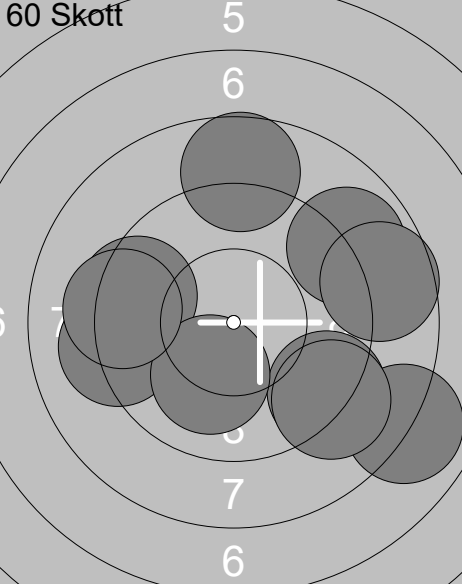
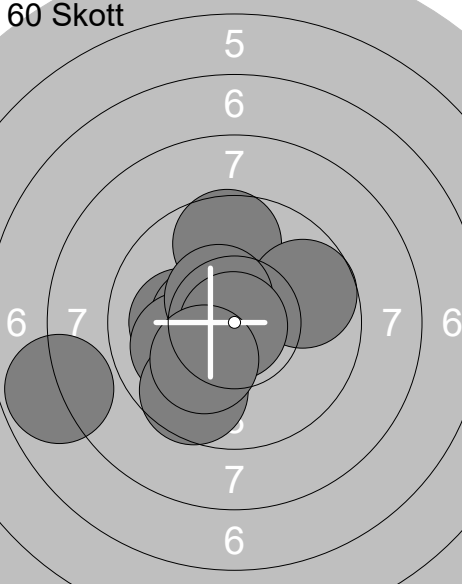
Skjutlag	Tavla	Frida Hornejj	
3	11	Ramselefors	Östhammar
04.11.2018		Vindelnskyttet 2018	Ramselefors SKF
17S	Up		
Prov		1: 9.4 ↗ 2: 8.1 ← 3: 8.3 ↓ 4: 10.1 ↓ 5: 9.7 ↓ 6: 8.8 ↓ 7: 9.3 ↓ 8: 9.6 ↗ 9: 9.6 ↓ 10: 6.7 →	11: 8.7 → 12: 8.4 → 13: 8.9 ↗ 14: 10.1 ← 15: 7.8 ↗ 16: 9.5 ↑ 17: 9.5 ← 18: 8.2 ↗ 19: 8.9 ↗ 20: 8.1 ↗
		Serie 89.6	Serie 88.1
		Total 0.0	Total 0.0
Prov		21: 8.9 ↑ 22: 9.3 ↑	60 Skott 1: 9.3 → 2: 8.8 ↗ 3: 10.8x ↗ 4: 8.9 → 5: 9.6 ↗ 6: 10.3x ← 7: 8.4 ↓ 8: 8.5 ↗ 9: 9.8 ↗ 10: 9.3 →
		Serie 18.2	Serie 93.7
		Total 0.0	Total 93.7
60 Skott		11: 9.1 ← 12: 10.1 ↓ 13: 8.9 ← 14: 9.8 ← 15: 9.2 ↓ 16: 10.1 ↓ 17: 9.8 ↓ 18: 10.2x ← 19: 10.0 → 20: 9.0 ↑	60 Skott 21: 8.6 ← 22: 10.1 ↑ 23: 10.1 ← 24: 8.5 → 25: 8.7 → 26: 10.3x ↗ 27: 8.9 ↗ 28: 10.5x ↓ 29: 10.2x ↑ 30: 8.6 ↗
		Serie 96.2	Serie 94.5
		Total 189.9	Total 284.4
60 Skott		31: 9.7 ↑ 32: 10.2x ↗ 33: 9.5 ← 34: 10.4x ↓ 35: 9.2 ↗ 36: 9.7 ← 37: 8.5 ↗ 38: 9.3 ↗ 39: 8.7 ↓ 40: 10.1 ↑	60 Skott 41: 9.8 ↓ 42: 9.9 → 43: 9.9 ← 44: 10.2x ↑ 45: 10.5x ↗ 46: 9.9 → 47: 9.3 → 48: 10.8x ↗ 49: 8.3 ↓ 50: 10.3x ↗
		Serie 95.3	Serie 98.9
		Total 379.7	Total 478.6
60 Skott		51: 10.1 ↗ 52: 8.3 ↑ 53: 9.5 → 54: 9.0 → 55: 10.7x ← 56: 9.9 ↓ 57: 9.6 ↑ 58: 8.4 ↗ 59: 7.4 → 60: 9.7 ↓	
		Serie 92.6	
		Total 571.2	

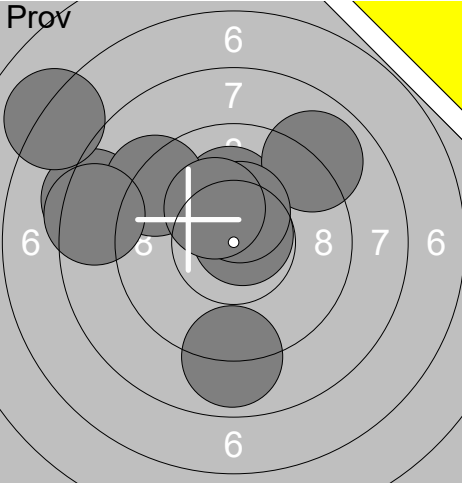
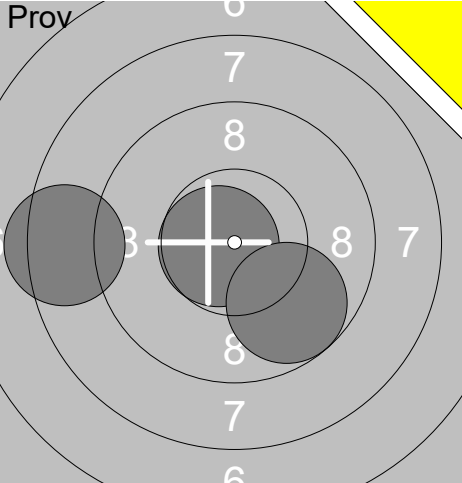
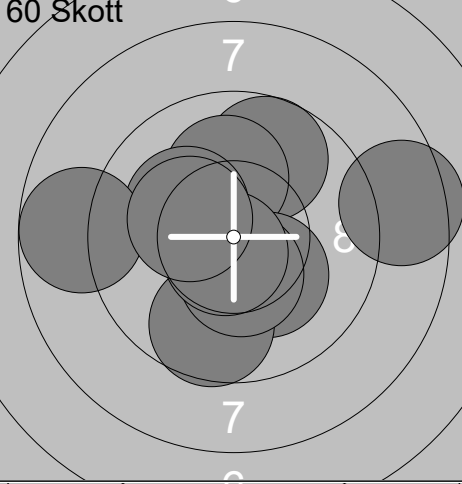
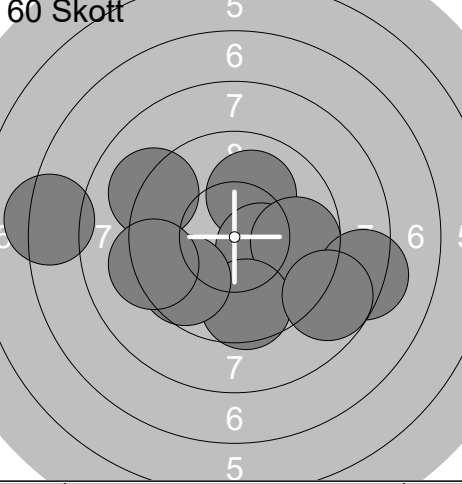
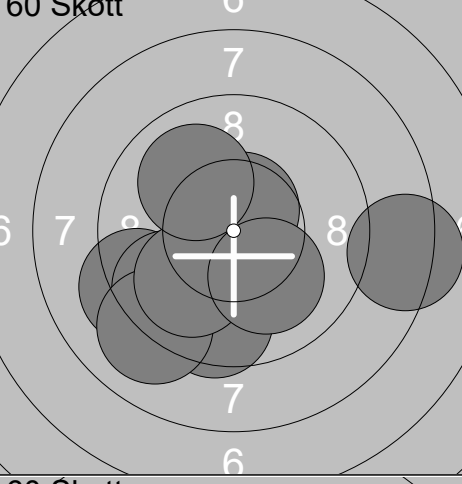
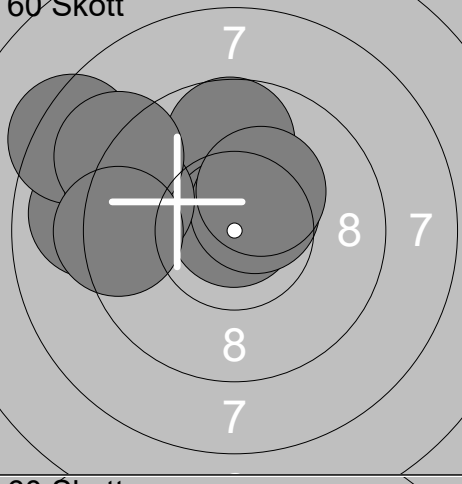
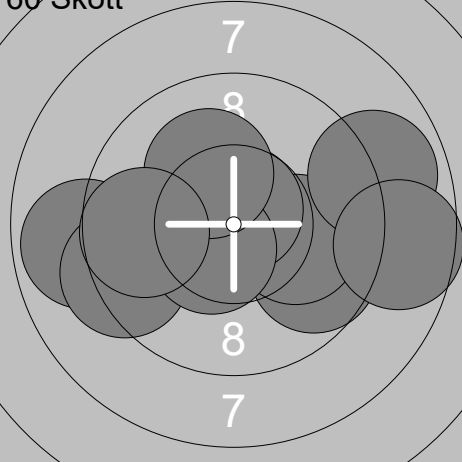
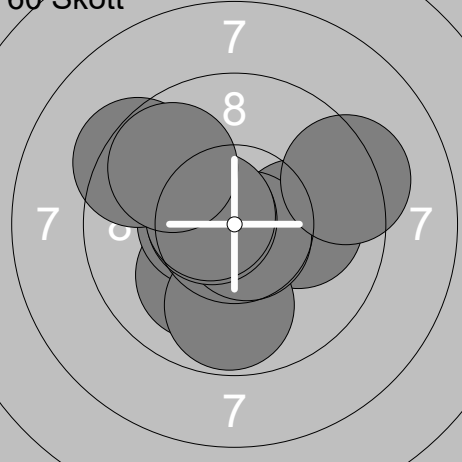
Skjuttlag	Tavla	Anna Grönlund	
3	12	Ramselefors	Piteå
04.11.2018	Vindelnskyttet 2018	15S	No
Prov		Prov	
	1: 7.8 ← 2: 8.7 → 3: 8.8 → 4: 1.8 ↘ 5: 10.2x ↘ 6: 8.1 ↓ 7: 9.0 ← 8: 10.0 ← 9: 6.8 ← 10: 8.7 →		11: 7.8 ← 12: 7.7 ↘ 13: 10.7x ↘ 14: 9.1 ↘ 15: 10.7x ←
Serie	79.9	Serie	46.0
Total	0.0	Total	0.0
60 Skott		60 Skott	
	1: 9.7 ↗ 2: 9.8 ↗ 3: 8.8 ↘ 4: 8.9 ← 5: 8.6 → 6: 9.0 ← 7: 8.0 ← 8: 10.0 ↓ 9: 9.6 ↘ 10: 7.9 ←		11: 9.0 ↓ 12: 10.3x ← 13: 8.8 ← 14: 9.5 ↘ 15: 9.9 ← 16: 10.2x → 17: 7.8 ← 18: 0.0 ↑ 19: 7.7 → 20: 10.1 ↗
Serie	90.3	Serie	83.3
Total	90.3	Total	173.6
60 Skott		60 Skott	
	21: 9.4 ← 22: 9.2 ↘ 23: 8.0 ↘ 24: 8.9 ↗ 25: 9.2 ← 26: 10.1 ↓ 27: 9.3 ← 28: 8.7 → 29: 8.7 ↑ 30: 9.1 ↘		31: 7.8 ← 32: 10.1 ← 33: 9.6 ↑ 34: 10.5x ← 35: 10.0 ← 36: 9.7 → 37: 10.5x ↗ 38: 9.6 ↘ 39: 10.9x ↘ 40: 10.2x ↘
Serie	90.6	Serie	98.9
Total	264.2	Total	363.1

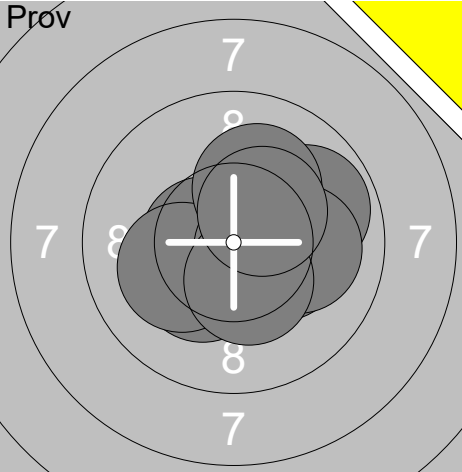
Skjutlag	Tavla	Wilma Wadman	
3	13	Ramselefors	Hållnäs
04.11.2018		Vindelnskyttet 2018	Ramselefors SKF
17S	Up		
Prov		1: 8.3 ← 2: 10.1 ↑ 3: 8.9 ↗ 4: 9.2 ↗ 5: 10.7x ↗ 6: 7.1 ↗ 7: 10.4x ↑ 8: 8.4 ← 9: 8.9 ↓ 10: 10.3x ↗ Serie 92.3 Total 0.0	Prov  11: 10.7x ← 12: 8.4 ← 13: 9.8 ↘ Serie 28.9 Total 0.0
60 Skott		1: 9.7 ↑ 2: 10.1 ↑ 3: 10.2x ↗ 4: 10.2x ↘ 5: 9.7 ↓ 6: 10.4x ↓ 7: 8.8 ← 8: 10.7x ↓ 9: 10.3x ↗ 10: 8.5 → Serie 98.6 Total 98.6	60 Skott  11: 10.1 ↑ 12: 10.4x ↘ 13: 9.1 ↗ 14: 9.7 → 15: 7.3 ← 16: 9.6 ↓ 17: 8.3 → 18: 8.8 ↘ 19: 9.7 ↘ 20: 9.2 ← Serie 92.2 Total 190.8
60 Skott		21: 9.5 ↓ 22: 9.2 ← 23: 10.6x ↘ 24: 10.6x ↑ 25: 9.6 ↘ 26: 9.0 ↘ 27: 8.3 → 28: 10.0 ↘ 29: 10.1 ↘ 30: 10.0 ↗ Serie 96.9 Total 287.7	60 Skott  31: 9.0 ← 32: 10.1 ↑ 33: 8.4 ↗ 34: 9.7 ↑ 35: 10.8x ↑ 36: 10.5x ↗ 37: 9.4 ← 38: 9.0 ↗ 39: 9.3 ← 40: 10.3x ↗ Serie 96.5 Total 384.2
60 Skott		41: 9.7 → 42: 10.1 → 43: 8.9 → 44: 8.9 ← 45: 8.6 → 46: 10.7x ↑ 47: 9.3 ← 48: 10.5x ↘ 49: 10.2x ↗ 50: 9.7 ← Serie 96.6 Total 480.8	60 Skott  51: 10.1 ↘ 52: 10.5x ← 53: 9.4 ↗ 54: 10.1 → 55: 9.8 ↓ 56: 10.7x ↘ 57: 10.6x ← 58: 10.6x ↗ 59: 9.8 ↗ 60: 9.3 → Serie 100.9 Total 581.7

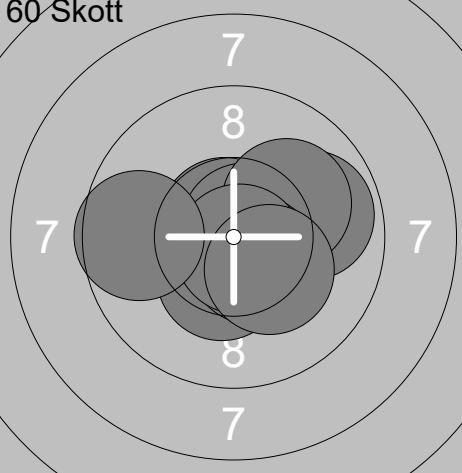
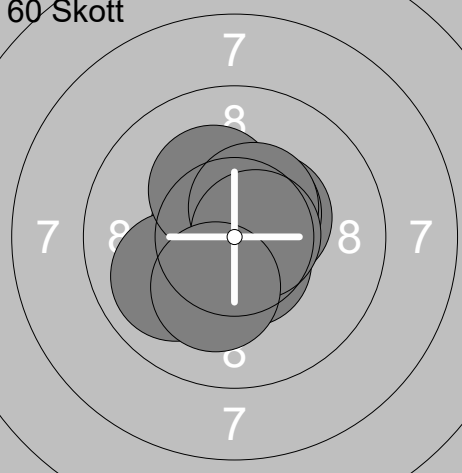
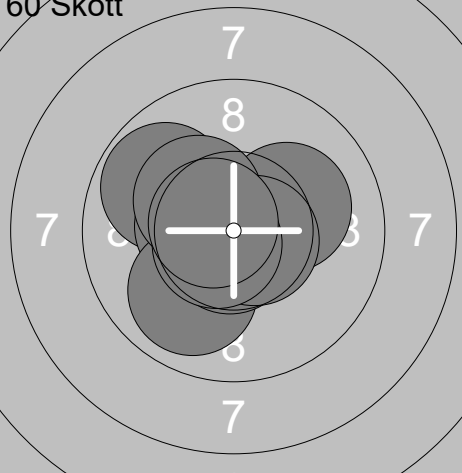
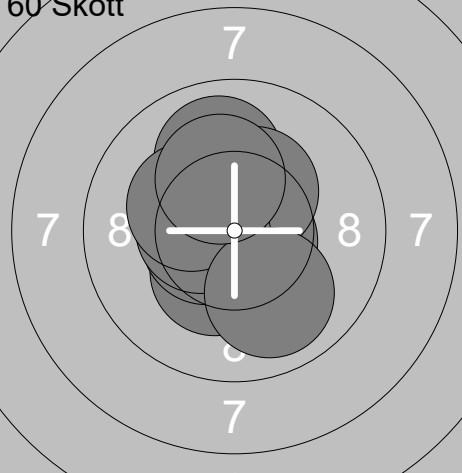
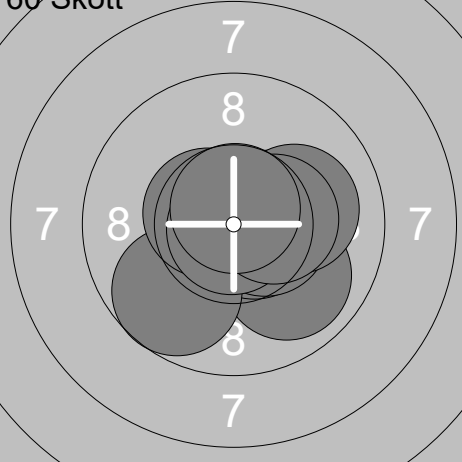
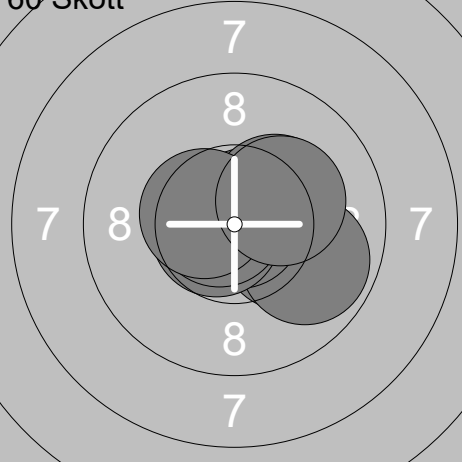
Skjuttag	Tavla	Lotten Johansson			
3	15	Ramselefors	Ramselefors	Sen	Vb
04.11.2018	Vindelnskyttet 2018	Ramselefors SKF			
Pröv 	1: 10.3x ↙ 2: 10.6x ← 3: 10.2x ↙ 4: 9.9 → 5: 10.3x → 6: 10.6x → 7: 10.1 → 8: 10.4x ↓ 9: 10.1 ↗ 10: 10.4x ↗ Serie 102.9 Total 0.0	Pröv 	11: 10.7x ← 12: 10.2x ↗ 13: 10.1 ↗ 14: 10.6x ↑ 15: 10.3x ↗ Serie 51.9 Total 0.0		
60 Skott 	1: 10.7x ↗ 2: 10.4x ↓ 3: 10.7x ↗ 4: 9.9 → 5: 10.7x ↗ 6: 10.1 ↗ 7: 10.5x ↓ 8: 10.8x ↓ 9: 10.3x ↓ 10: 9.6 ← Serie 103.7 Total 103.7	60 Skott 	11: 10.4x ↓ 12: 10.6x ↓ 13: 10.7x ↙ 14: 10.4x → 15: 10.5x ↗ 16: 10.0 ← 17: 10.2x ↗ 18: 10.5x ↗ 19: 10.7x → 20: 10.2x ↓ Serie 104.2 Total 207.9		
60 Skott 	21: 10.7x → 22: 10.2x → 23: 9.8 ↗ 24: 10.5x ← 25: 9.9 ↓ 26: 10.7x ↓ 27: 10.3x ↗ 28: 10.6x → 29: 10.7x ↙ 30: 10.6x ↗ Serie 104.0 Total 311.9	60 Skott 	31: 10.6x ↓ 32: 10.3x ↓ 33: 10.7x → 34: 10.0 ↗ 35: 10.3x ↗ 36: 10.5x ← 37: 10.5x ← 38: 10.3x ↙ 39: 10.0 ↓ 40: 10.2x ↗ Serie 103.4 Total 415.3		
60 Skott 	41: 9.9 ↓ 42: 10.6x ↓ 43: 10.5x → 44: 9.7 ↓ 45: 10.5x → 46: 10.6x ↗ 47: 10.9x ↓ 48: 10.1 → 49: 10.4x → 50: 10.7x ↑ Serie 103.9 Total 519.2	60 Skott 	51: 10.2x → 52: 10.7x ↗ 53: 9.9 → 54: 10.9x → 55: 10.7x ← 56: 10.7x ← 57: 10.3x ↗ 58: 10.7x ← 59: 10.5x ↙ 60: 10.2x ↗ Serie 104.8 Total 624.0		

Skjutlag	Tavla	Maria Lundgren	
3	16		
Ramselefors	Hållnäs	Sen	Up
04.11.2018	Vindelnskyttet 2018	Ramselefors SKF	
Prov 	1: 8.8 → 2: 9.9 ↑ 3: 9.4 → 4: 9.8 ↑ 5: 9.6 → 6: 9.7 ↗ 7: 9.4 → 8: 9.5 → 9: 10.0 ↗ 10: 9.9 ↘ Serie 96.0 Total 0.0	Prov 	11: 10.2x ↗ 12: 10.0 → 13: 10.7x → 14: 9.0 ↗ 15: 9.7 ↓ 16: 10.2x ↗ Serie 59.8 Total 0.0
60 Skott 	1: 10.1 ↗ 2: 10.2x ↓ 3: 10.1 ← 4: 10.2x ↘ 5: 10.5x ↓ 6: 10.6x ← 7: 10.3x ↑ 8: 9.7 ← 9: 10.0 ↗ 10: 10.0 ↗ Serie 101.7 Total 101.7	60 Skott 	11: 10.7x ↘ 12: 10.7x ← 13: 9.4 ← 14: 10.5x → 15: 9.4 ← 16: 9.1 ↓ 17: 9.8 ↓ 18: 10.4x ↗ 19: 10.6x ↓ 20: 10.1 ↓ Serie 100.7 Total 202.4
60 Skott 	21: 10.9x ↓ 22: 10.4x ↓ 23: 10.1 → 24: 8.9 → 25: 9.6 ↓ 26: 10.1 → 27: 10.3x ↓ 28: 10.5x ↗ 29: 10.3x ← 30: 10.3x ↓ Serie 101.4 Total 303.8	60 Skott 	31: 10.9x ↑ 32: 10.0 ↘ 33: 10.3x ← 34: 10.2x ↓ 35: 10.3x ↓ 36: 9.9 ↗ 37: 10.7x ↗ 38: 9.7 → 39: 10.8x ↗ 40: 10.5x → Serie 103.3 Total 407.1
60 Skott 	41: 10.1 ↘ 42: 10.8x ↘ 43: 10.2x ↓ 44: 9.4 ↘ 45: 10.0 ↓ 46: 9.7 ↘ 47: 10.7x ↗ 48: 10.7x ↓ 49: 10.0 → 50: 9.7 ↓ Serie 101.3 Total 508.4	60 Skott 	51: 9.5 ↗ 52: 9.4 ← 53: 9.3 ↓ 54: 9.8 ↓ 55: 10.4x → 56: 10.3x → 57: 10.7x ↗ 58: 10.1 ↓ 59: 9.8 ↘ 60: 10.5x → Serie 99.8 Total 608.2

Skjuttag	Tavla	Maria Hägglund					
3	17	Ramselefors	Ramselefors	Sen	Vb		
04.11.2018	Vindelnskyttet 2018	Ramselefors SKF					
Prov 	1: 8.9 ↓ 2: 9.5 ← 3: 9.9 ↙ 4: 10.1 ↗ 5: 10.3x ↑ 6: 10.0 ↗ 7: 9.3 ↑ 8: 10.7x ↘ 9: 10.5x → 10: 10.4x ↓	Prov 	11: 10.4x ↘ 12: 10.3x ↘ 13: 10.7x → 14: 10.6x ↓ 15: 9.9 ↑ 16: 10.3x ↗ 17: 9.7 ↓ 18: 10.5x →	Serie	99.6	Serie	82.4
	Total		0.0	Total	0.0		
	60 Skott 		1: 9.7 ↗ 2: 9.8 ↗ 3: 10.2x ↘ 4: 10.4x ↙ 5: 10.2x ↓ 6: 9.5 ↘ 7: 10.6x ↘ 8: 10.4x → 9: 10.8x ← 10: 10.8x ↓	60 Skott 	11: 10.4x ↗ 12: 10.0 ↘ 13: 10.1 ↓ 14: 10.3x ↗ 15: 10.5x ← 16: 10.5x ↓ 17: 10.4x ↘ 18: 9.7 ↗ 19: 10.1 ↑ 20: 10.4x →	Serie	102.4
Total		102.4	Total		204.8		
60 Skott 		21: 10.2x → 22: 9.7 → 23: 10.5x ↓ 24: 10.1 → 25: 10.9x ↓ 26: 10.4x ↗ 27: 10.6x ↓ 28: 10.0 → 29: 10.0 ↗ 30: 10.5x ↙	60 Skott 		31: 10.2x ↗ 32: 10.5x ↗ 33: 10.6x ↗ 34: 10.4x ← 35: 10.6x ↓ 36: 9.9 ↗ 37: 10.4x → 38: 10.1 ↗ 39: 10.2x ↑ 40: 10.6x ↑	Serie	102.9
	Total	307.7		Total	411.2		
	60 Skott 	41: 10.8x ↑ 42: 10.4x ← 43: 10.6x ↓ 44: 10.5x ← 45: 10.7x ← 46: 10.7x ↓ 47: 10.4x ← 48: 10.7x ↓ 49: 10.1 ← 50: 10.3x →		60 Skott 	51: 10.5x ↘ 52: 10.3x → 53: 10.4x ↗ 54: 10.4x ↑ 55: 10.3x ↗ 56: 10.8x ↘ 57: 9.9 → 58: 10.8x ↗ 59: 10.0 ← 60: 10.6x ↙	Serie	105.2
Total		516.4	Total		620.4		

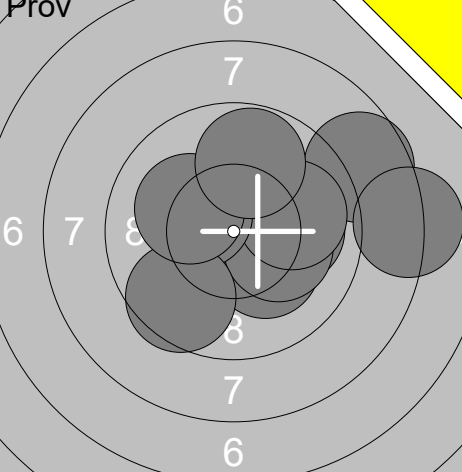
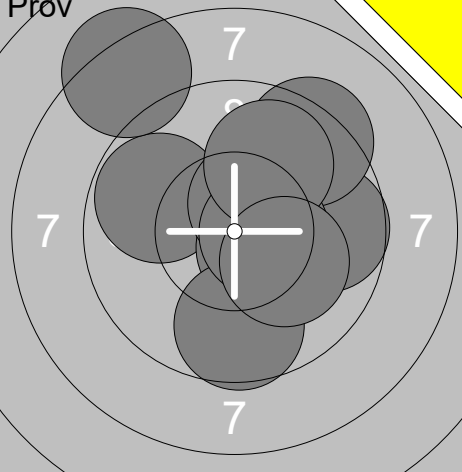
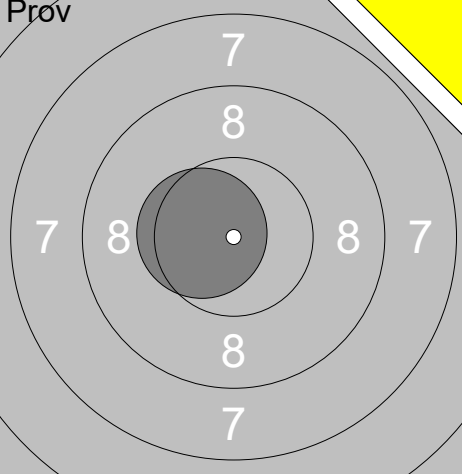
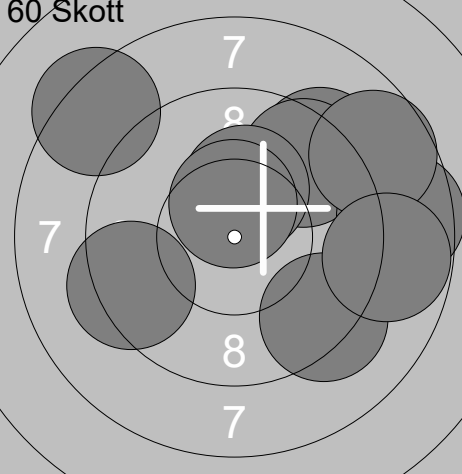
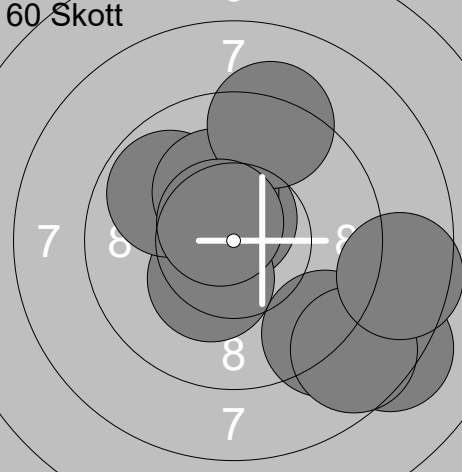
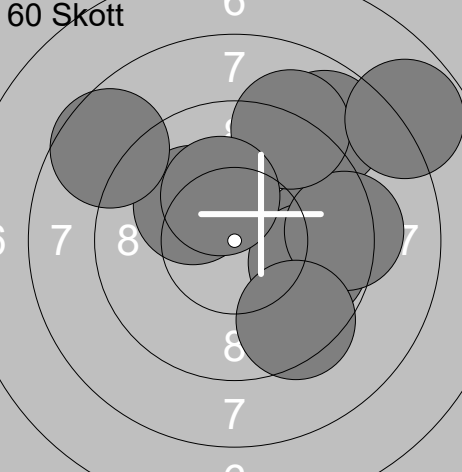
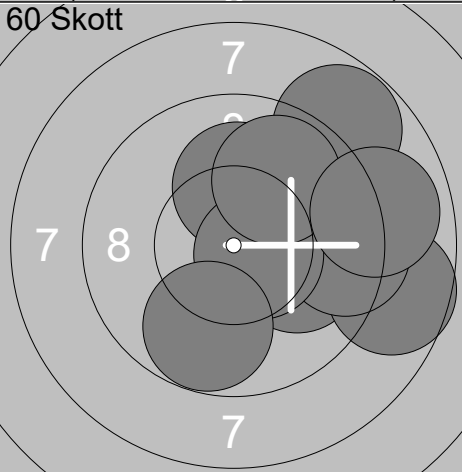
<p>Prov</p> 	<table style="width:100%; border-collapse: collapse;"> <tr><td>1:</td><td>10.2x</td><td>↘</td></tr> <tr><td>2:</td><td>8.7</td><td>→</td></tr> <tr><td>3:</td><td>10.0</td><td>→</td></tr> <tr><td>4:</td><td>8.1</td><td>→</td></tr> <tr><td>5:</td><td>10.2x</td><td>→</td></tr> <tr><td>6:</td><td>10.0</td><td>→</td></tr> <tr><td>7:</td><td>10.3x</td><td>↗</td></tr> <tr><td>8:</td><td>9.6</td><td>↙</td></tr> <tr><td>9:</td><td>10.1</td><td>↖</td></tr> <tr><td>10:</td><td>9.8</td><td>↑</td></tr> <tr style="border-top: 1px solid black;"><td colspan="2">Serie</td><td style="text-align: right;">97.0</td></tr> <tr><td colspan="2">Total</td><td style="text-align: right;">0.0</td></tr> </table>	1:	10.2x	↘	2:	8.7	→	3:	10.0	→	4:	8.1	→	5:	10.2x	→	6:	10.0	→	7:	10.3x	↗	8:	9.6	↙	9:	10.1	↖	10:	9.8	↑	Serie		97.0	Total		0.0	<p>Prov</p> 	<table style="width:100%; border-collapse: collapse;"> <tr><td>11:</td><td>9.8</td><td>↖</td></tr> <tr><td>12:</td><td>10.5x</td><td>↘</td></tr> <tr><td>13:</td><td>8.3</td><td>↗</td></tr> <tr><td>14:</td><td>9.7</td><td>→</td></tr> <tr><td>15:</td><td>10.5x</td><td>↗</td></tr> <tr><td>16:</td><td>9.6</td><td>↓</td></tr> <tr><td>17:</td><td>9.3</td><td>↗</td></tr> <tr><td>18:</td><td>10.5x</td><td>→</td></tr> <tr><td>19:</td><td>9.9</td><td>↗</td></tr> <tr><td>20:</td><td>10.1</td><td>↘</td></tr> <tr style="border-top: 1px solid black;"><td colspan="2">Serie</td><td style="text-align: right;">98.2</td></tr> <tr><td colspan="2">Total</td><td style="text-align: right;">0.0</td></tr> </table>	11:	9.8	↖	12:	10.5x	↘	13:	8.3	↗	14:	9.7	→	15:	10.5x	↗	16:	9.6	↓	17:	9.3	↗	18:	10.5x	→	19:	9.9	↗	20:	10.1	↘	Serie		98.2	Total		0.0
1:	10.2x	↘																																																																									
2:	8.7	→																																																																									
3:	10.0	→																																																																									
4:	8.1	→																																																																									
5:	10.2x	→																																																																									
6:	10.0	→																																																																									
7:	10.3x	↗																																																																									
8:	9.6	↙																																																																									
9:	10.1	↖																																																																									
10:	9.8	↑																																																																									
Serie		97.0																																																																									
Total		0.0																																																																									
11:	9.8	↖																																																																									
12:	10.5x	↘																																																																									
13:	8.3	↗																																																																									
14:	9.7	→																																																																									
15:	10.5x	↗																																																																									
16:	9.6	↓																																																																									
17:	9.3	↗																																																																									
18:	10.5x	→																																																																									
19:	9.9	↗																																																																									
20:	10.1	↘																																																																									
Serie		98.2																																																																									
Total		0.0																																																																									
<p>Prov</p> 	<table style="width:100%; border-collapse: collapse;"> <tr><td>21:</td><td>10.5x</td><td>←</td></tr> <tr style="border-top: 1px solid black;"><td colspan="2">Serie</td><td style="text-align: right;">10.5</td></tr> <tr><td colspan="2">Total</td><td style="text-align: right;">0.0</td></tr> </table>	21:	10.5x	←	Serie		10.5	Total		0.0	<p>60 Skott</p> 	<table style="width:100%; border-collapse: collapse;"> <tr><td>1:</td><td>9.3</td><td>↗</td></tr> <tr><td>2:</td><td>8.3</td><td>↖</td></tr> <tr><td>3:</td><td>9.5</td><td>↗</td></tr> <tr><td>4:</td><td>9.3</td><td>↖</td></tr> <tr><td>5:</td><td>9.3</td><td>↘</td></tr> <tr><td>6:</td><td>8.6</td><td>→</td></tr> <tr><td>7:</td><td>10.3x</td><td>↑</td></tr> <tr><td>8:</td><td>8.7</td><td>↗</td></tr> <tr><td>9:</td><td>8.8</td><td>→</td></tr> <tr><td>10:</td><td>10.5x</td><td>↑</td></tr> <tr style="border-top: 1px solid black;"><td colspan="2">Serie</td><td style="text-align: right;">92.6</td></tr> <tr><td colspan="2">Total</td><td style="text-align: right;">92.6</td></tr> </table>	1:	9.3	↗	2:	8.3	↖	3:	9.5	↗	4:	9.3	↖	5:	9.3	↘	6:	8.6	→	7:	10.3x	↑	8:	8.7	↗	9:	8.8	→	10:	10.5x	↑	Serie		92.6	Total		92.6																											
21:	10.5x	←																																																																									
Serie		10.5																																																																									
Total		0.0																																																																									
1:	9.3	↗																																																																									
2:	8.3	↖																																																																									
3:	9.5	↗																																																																									
4:	9.3	↖																																																																									
5:	9.3	↘																																																																									
6:	8.6	→																																																																									
7:	10.3x	↑																																																																									
8:	8.7	↗																																																																									
9:	8.8	→																																																																									
10:	10.5x	↑																																																																									
Serie		92.6																																																																									
Total		92.6																																																																									
<p>60 Skott</p> 	<table style="width:100%; border-collapse: collapse;"> <tr><td>11:</td><td>10.6x</td><td>↑</td></tr> <tr><td>12:</td><td>8.3</td><td>↘</td></tr> <tr><td>13:</td><td>9.1</td><td>↘</td></tr> <tr><td>14:</td><td>10.3x</td><td>↘</td></tr> <tr><td>15:</td><td>9.8</td><td>↗</td></tr> <tr><td>16:</td><td>10.2x</td><td>↗</td></tr> <tr><td>17:</td><td>9.2</td><td>↑</td></tr> <tr><td>18:</td><td>8.7</td><td>↘</td></tr> <tr><td>19:</td><td>10.6x</td><td>↗</td></tr> <tr><td>20:</td><td>8.6</td><td>→</td></tr> <tr style="border-top: 1px solid black;"><td colspan="2">Serie</td><td style="text-align: right;">95.4</td></tr> <tr><td colspan="2">Total</td><td style="text-align: right;">188.0</td></tr> </table>	11:	10.6x	↑	12:	8.3	↘	13:	9.1	↘	14:	10.3x	↘	15:	9.8	↗	16:	10.2x	↗	17:	9.2	↑	18:	8.7	↘	19:	10.6x	↗	20:	8.6	→	Serie		95.4	Total		188.0	<p>60 Skott</p> 	<table style="width:100%; border-collapse: collapse;"> <tr><td>21:</td><td>9.7</td><td>→</td></tr> <tr><td>22:</td><td>9.8</td><td>→</td></tr> <tr><td>23:</td><td>10.1</td><td>↖</td></tr> <tr><td>24:</td><td>8.8</td><td>↗</td></tr> <tr><td>25:</td><td>9.3</td><td>→</td></tr> <tr><td>26:</td><td>9.4</td><td>↘</td></tr> <tr><td>27:</td><td>8.6</td><td>↖</td></tr> <tr><td>28:</td><td>9.1</td><td>↑</td></tr> <tr><td>29:</td><td>7.8</td><td>↗</td></tr> <tr><td>30:</td><td>10.2x</td><td>↑</td></tr> <tr style="border-top: 1px solid black;"><td colspan="2">Serie</td><td style="text-align: right;">92.8</td></tr> <tr><td colspan="2">Total</td><td style="text-align: right;">280.8</td></tr> </table>	21:	9.7	→	22:	9.8	→	23:	10.1	↖	24:	8.8	↗	25:	9.3	→	26:	9.4	↘	27:	8.6	↖	28:	9.1	↑	29:	7.8	↗	30:	10.2x	↑	Serie		92.8	Total		280.8
11:	10.6x	↑																																																																									
12:	8.3	↘																																																																									
13:	9.1	↘																																																																									
14:	10.3x	↘																																																																									
15:	9.8	↗																																																																									
16:	10.2x	↗																																																																									
17:	9.2	↑																																																																									
18:	8.7	↘																																																																									
19:	10.6x	↗																																																																									
20:	8.6	→																																																																									
Serie		95.4																																																																									
Total		188.0																																																																									
21:	9.7	→																																																																									
22:	9.8	→																																																																									
23:	10.1	↖																																																																									
24:	8.8	↗																																																																									
25:	9.3	→																																																																									
26:	9.4	↘																																																																									
27:	8.6	↖																																																																									
28:	9.1	↑																																																																									
29:	7.8	↗																																																																									
30:	10.2x	↑																																																																									
Serie		92.8																																																																									
Total		280.8																																																																									
<p>60 Skott</p> 	<table style="width:100%; border-collapse: collapse;"> <tr><td>31:</td><td>10.1</td><td>→</td></tr> <tr><td>32:</td><td>10.1</td><td>↑</td></tr> <tr><td>33:</td><td>10.0</td><td>↘</td></tr> <tr><td>34:</td><td>8.7</td><td>↘</td></tr> <tr><td>35:</td><td>9.4</td><td>→</td></tr> <tr><td>36:</td><td>8.8</td><td>↗</td></tr> <tr><td>37:</td><td>10.6x</td><td>↘</td></tr> <tr><td>38:</td><td>9.9</td><td>↗</td></tr> <tr><td>39:</td><td>9.8</td><td>↓</td></tr> <tr><td>40:</td><td>8.9</td><td>→</td></tr> <tr style="border-top: 1px solid black;"><td colspan="2">Serie</td><td style="text-align: right;">96.3</td></tr> <tr><td colspan="2">Total</td><td style="text-align: right;">377.1</td></tr> </table>	31:	10.1	→	32:	10.1	↑	33:	10.0	↘	34:	8.7	↘	35:	9.4	→	36:	8.8	↗	37:	10.6x	↘	38:	9.9	↗	39:	9.8	↓	40:	8.9	→	Serie		96.3	Total		377.1																																						
31:	10.1	→																																																																									
32:	10.1	↑																																																																									
33:	10.0	↘																																																																									
34:	8.7	↘																																																																									
35:	9.4	→																																																																									
36:	8.8	↗																																																																									
37:	10.6x	↘																																																																									
38:	9.9	↗																																																																									
39:	9.8	↓																																																																									
40:	8.9	→																																																																									
Serie		96.3																																																																									
Total		377.1																																																																									

Skjutlag	Tavla	Anna Östman					
3	19	Ramselefors	Ramselefors	Sen	Vb		
04.11.2018	Vindelnskyttet 2018	Ramselefors SKF					
Prov 	1: 10.1 ↓ 2: 10.3x ← 3: 9.6 ← 4: 9.3 ↓ 5: 10.0 ↓ 6: 10.7x ↑ 7: 10.5x ↗ 8: 9.3 ← 9: 10.0 ↗ 10: 10.2x ↖	Prov 	11: 10.8x ↓ 12: 10.0 ← 13: 10.7x → 14: 10.7x ↑ 15: 10.0 ↗ 16: 10.7x ↗ 17: 10.1 ←	Serie	100.0	Serie	73.0
	Total		0.0	Total	0.0		
	60 Skott 		1: 10.4x ↖ 2: 10.3x ↗ 3: 9.0 → 4: 10.0 ↑ 5: 10.0 ↓ 6: 10.4x ← 7: 10.5x ← 8: 10.3x → 9: 10.1 ↗ 10: 9.7 ←	60 Skott 	11: 10.0 ← 12: 9.8 → 13: 10.3x → 14: 10.5x ↗ 15: 10.2x ↗ 16: 9.5 ← 17: 10.2x ↓ 18: 8.9 → 19: 8.7 ↓ 20: 9.9 ↗	Serie	100.7
Total		100.7	Total		198.7		
60 Skott 		21: 9.9 → 22: 10.2x ↗ 23: 9.9 ← 24: 9.9 ↓ 25: 9.8 ↓ 26: 10.8x ← 27: 9.5 → 28: 10.1 ↓ 29: 10.4x ↓ 30: 10.8x →	60 Skott 		31: 9.9 → 32: 10.9x ↓ 33: 10.2x ↓ 34: 10.0 ↓ 35: 8.8 ← 36: 9.7 ↓ 37: 9.8 ↓ 38: 10.6x ↓ 39: 10.2x → 40: 10.8x →	Serie	101.3
	Total	300.0		Total	400.9		
	60 Skott 	41: 10.4x ↗ 42: 10.9x ← 43: 10.2x ↓ 44: 10.5x ← 45: 10.5x ↓ 46: 9.2 ↖ 47: 10.0 ← 48: 10.2x → 49: 8.7 ← 50: 10.2x ↑		60 Skott 	51: 10.5x ↗ 52: 10.0 ↖ 53: 9.5 ← 54: 9.6 → 55: 9.9 ← 56: 9.9 ↑ 57: 10.4x ↖ 58: 9.7 ← 59: 10.6x ↗ 60: 9.7 ←	Serie	100.8
Total		501.7	Total		601.5		

Skjutlag 3	Tavla 21	Jonathan Sundström			
Ramselefors		Rönnskär		Sen	Vb
04.11.2018		Vindelnskyttet 2018		Ramselefors SKF	
Prov 	1: 6.0 ← 2: 8.8 ↙ 3: 8.9 ↙ 4: 6.5 ↗ 5: 6.9 ↗ 6: 9.9 ↙ 7: 8.9 ← 8: 8.4 ← 9: 8.3 ← 10: 10.5x ↘ Serie 83.1 Total 0.0	Prov 	11: 10.0 ← 12: 6.0 ↙ 13: 8.7 ↑ 14: 9.0 ↗ 15: 8.3 ↗ 16: 9.9 ← 17: 7.6 → 18: 6.6 ↗ 19: 9.3 → 20: 6.9 ↗ Serie 82.3 Total 0.0		
Prov 	21: 10.4x ↗ 22: 6.5 ↗ 23: 8.3 ↗ 24: 9.0 ↗ 25: 9.2 ↙ 26: 10.1 ↗ 27: 8.0 ↗ 28: 9.3 ↙ Serie 70.8 Total 0.0	60 Skott 	1: 6.9 ↗ 2: 8.4 ← 3: 8.5 → 4: 10.1 ↗ 5: 9.2 ↗ 6: 8.8 ↗ 7: 7.1 ← 8: 8.0 → 9: 6.2 → 10: 9.5 ↗ Serie 82.7 Total 82.7		
60 Skott 	11: 10.2x ↙ 12: 3.9 ↗ 13: 4.9 ↗ 14: 9.1 ↑ 15: 6.7 → 16: 9.2 ↗ 17: 5.9 ↘ 18: 10.0 ↗ 19: 10.1 ← 20: 8.7 ← Serie 78.7 Total 161.4	60 Skott 	21: 9.3 → 22: 8.6 ↗ 23: 9.6 ↑ 24: 10.0 ↑ 25: 10.1 ← 26: 6.6 ← 27: 8.2 → 28: 9.7 ↗ 29: 5.6 ↗ 30: 8.6 ↗ Serie 86.3 Total 247.7		
60 Skott 	31: 0.0 → 32: 8.3 ↗ 33: 9.2 ↘ 34: 7.1 ← 35: 8.5 ↗ 36: 8.7 ↑ 37: 5.7 ↗ 38: 7.6 ↑ 39: 9.3 ← 40: 9.1 ↘ Serie 73.5 Total 321.2				

Skjuttag	Tavla	Saul Johansson			
3	22	Ramselefors	Ramselefors	Sen	Vb
04.11.2018	Vindelnskyttet 2018	Ramselefors SKF			
Prov 	1: 10.5x ← 2: 10.3x ← 3: 9.7 ↗ 4: 10.1 ↗ 5: 10.5x → 6: 10.4x ↓ 7: 10.6x ← 8: 10.6x ↓ 9: 9.9 ↙ 10: 10.4x ↓	Prov 	11: 10.2x ↑ 12: 10.8x → 13: 10.7x ↑ 14: 10.2x ← 15: 9.8 → 16: 10.2x ↓ 17: 10.3x ←	Serie 103.0 Total 0.0	Serie 72.2 Total 0.0
60 Skott 	1: 10.5x → 2: 10.4x ↗ 3: 10.1 ↓ 4: 10.0 ↓ 5: 10.1 ↓ 6: 10.7x ↗ 7: 10.9x ↓ 8: 10.6x ↓ 9: 10.7x ↑ 10: 10.5x ←	60 Skott 	11: 9.9 ↙ 12: 10.6x ↓ 13: 10.4x ↓ 14: 10.7x ↗ 15: 10.0 ↓ 16: 10.5x ↑ 17: 10.1 → 18: 10.7x ↗ 19: 9.8 ↙ 20: 10.7x ←	Serie 104.5 Total 104.5	Serie 103.4 Total 207.9
60 Skott 	21: 9.6 → 22: 10.2x ↗ 23: 10.8x ↗ 24: 9.2 ↗ 25: 10.6x → 26: 10.7x ↓ 27: 9.7 ↓ 28: 10.2x ↖ 29: 10.7x ↓ 30: 10.3x ↓	60 Skott 	31: 10.8x ↗ 32: 10.3x ↓ 33: 9.9 ↘ 34: 9.8 ↑ 35: 9.9 ↗ 36: 10.5x ↑ 37: 10.3x ← 38: 10.1 ↘ 39: 10.4x → 40: 9.5 ↓	Serie 102.0 Total 309.9	Serie 101.5 Total 411.4
60 Skott 	41: 10.4x ↓ 42: 10.6x → 43: 9.7 ↓ 44: 10.7x ↖ 45: 10.1 ↑ 46: 9.9 ← 47: 10.4x ↗ 48: 10.4x ↓ 49: 10.6x ↓ 50: 10.5x ↗	60 Skott 	51: 9.9 ↓ 52: 10.0 ↓ 53: 10.6x ↑ 54: 10.2x ↘ 55: 10.7x ↓ 56: 9.8 ↖ 57: 9.1 ↘ 58: 10.5x ↘ 59: 10.6x ↑ 60: 10.0 ↓	Serie 103.3 Total 514.7	Serie 101.4 Total 616.1

Skjutlag	Tavla	Tomas Hed	
3	23		
Ramselefors	Forsa	Sen	Gä
04.11.2018	Vindelnskyttet 2018	Ramselefors SKF	
Prov 	1: 10.3x ↗ 2: 10.2x ↖ 3: 9.2 → 4: 10.0 ↗ 5: 9.7 ↗ 6: 9.9 → 7: 10.4x ↓ 8: 10.0 ↓ 9: 9.7 ↗ 10: 10.2x ↗ Serie 99.6 Total 0.0	Prov 	11: 9.9 ↗ 12: 10.7x ↑ 13: 10.6x ↗ 14: 10.0 → 15: 9.6 → 16: 10.7x ↓ Serie 61.5 Total 0.0
60 Skott 	1: 10.7x ↓ 2: 10.7x ↗ 3: 10.7x → 4: 9.2 → 5: 10.1 ↑ 6: 9.6 ↓ 7: 10.2x ↗ 8: 10.7x ↖ 9: 10.3x ↓ 10: 10.1 → Serie 102.3 Total 102.3	60 Skott 	11: 9.9 → 12: 10.7x ↖ 13: 9.6 ← 14: 9.8 → 15: 10.4x → 16: 10.6x ↖ 17: 10.7x ↑ 18: 9.7 ← 19: 10.0 ↗ 20: 10.6x ↑ Serie 102.0 Total 204.3
60 Skott 	21: 10.2x ↓ 22: 10.6x ↓ 23: 9.7 → 24: 10.3x ↗ 25: 10.5x ↓ 26: 10.1 ↗ 27: 9.9 ↗ 28: 10.4x ↗ 29: 10.3x ↗ 30: 10.1 ↑ Serie 102.1 Total 306.4	60 Skott 	31: 10.1 → 32: 9.7 ↓ 33: 10.5x ↗ 34: 10.1 ↖ 35: 9.2 ← 36: 10.1 ↑ 37: 10.0 → 38: 9.6 ← 39: 10.7x → 40: 10.2x ↖ Serie 100.2 Total 406.6
60 Skott 	41: 10.7x ↓ 42: 9.9 → 43: 9.5 ← 44: 10.2x ↗ 45: 10.0 ↑ 46: 10.6x ↑ 47: 9.9 ← 48: 9.7 ← 49: 9.8 ↑ 50: 10.4x ← Serie 100.7 Total 507.3	60 Skott 	51: 10.2x ← 52: 10.2x ← 53: 9.8 → 54: 10.2x ← 55: 9.9 → 56: 10.3x ↓ 57: 10.4x ↗ 58: 9.7 ↗ 59: 10.6x ← 60: 10.2x ↗ Serie 101.5 Total 608.8

Skjutlag	Tavla	Mattias Lind	
3	24	Ramselefors	Skoga-Ekshärad
04.11.2018	Vindelnskyttet 2018	Sen	Vä
Prov		Ramselefors SKF	
	1: 8.7 ↑ 2: 10.0 ↑ 3: 10.3x ← 4: 6.7 ↗ 5: 9.9 ↑ 6: 9.5 ↗ 7: 9.2 ↘ 8: 10.3x ↑ 9: 9.3 ↘ 10: 9.8 ↘ Serie 93.7 Total 0.0		11: 9.3 ↙ 12: 8.1 ↓ 13: 8.0 ↙ 14: 8.8 ↘ 15: 10.1 → 16: 8.9 ↙ 17: 9.5 ↑ 18: 9.9 ↑ 19: 10.3x ↓ 20: 9.1 ↗ Serie 92.0 Total 0.0
	1: 9.3 ↓ 2: 10.0 ↓ 3: 9.0 ↙ 4: 9.3 ↖ 5: 9.5 ↙ 6: 8.3 ↖ 7: 9.2 ↖ 8: 7.1 → 9: 10.0 ↓ 10: 10.2x ↗ Serie 91.9 Total 91.9		11: 10.7x ← 12: 10.7x ↑ 13: 9.5 → 14: 9.2 → 15: 9.6 ↗ 16: 10.4x ↗ 17: 9.1 ← 18: 9.8 ↘ 19: 10.4x → 20: 9.0 ← Serie 98.4 Total 190.3
	21: 9.1 ↗ 22: 8.5 ↗ 23: 10.0 ← 24: 8.7 ↘ 25: 10.0 ↗ 26: 9.8 ↘ 27: 9.8 ↓ 28: 9.7 ← 29: 10.2x → 30: 8.4 → Serie 94.2 Total 284.5		31: 8.5 ↘ 32: 10.5x → 33: 10.4x ↙ 34: 10.2x → 35: 6.3 ← 36: 6.9 ← 37: 9.9 → 38: 9.4 ↗ 39: 9.8 ↗ 40: 9.7 ↑ Serie 91.6 Total 376.1
	41: 8.8 ↘ 42: 10.3x → 43: 8.2 → 44: 9.9 ← 45: 8.5 ↘ 46: 9.0 ↓ 47: 9.7 → 48: 10.8x ← 49: 9.7 ↓ 50: 9.9 ↗ Serie 94.8 Total 470.9		51: 9.2 ↘ 52: 9.8 ↘ 53: 8.9 ← 54: 7.7 → 55: 10.2x ↗ 56: 9.4 ↘ 57: 9.7 ↗ 58: 9.5 ↗ 59: 9.7 ← 60: 9.5 ↗ Serie 93.6 Total 564.5

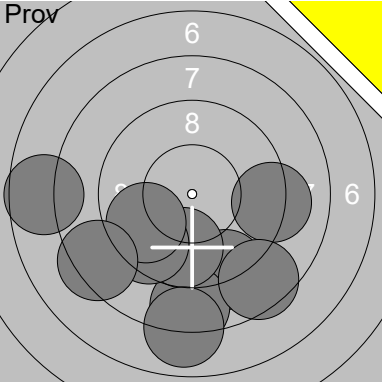
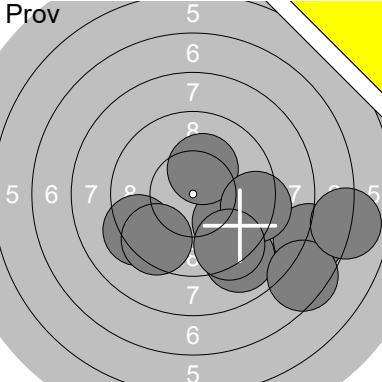
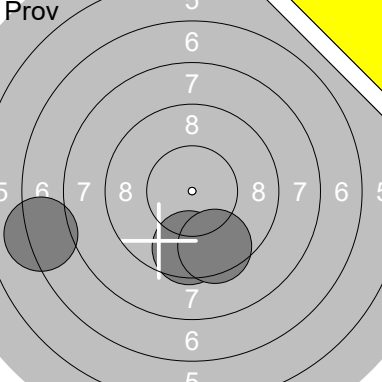
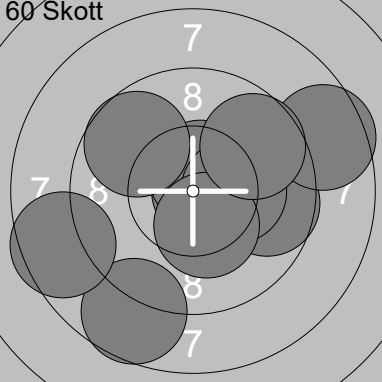
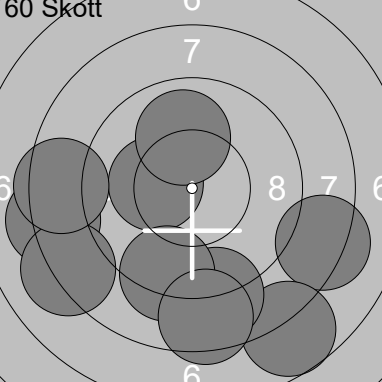
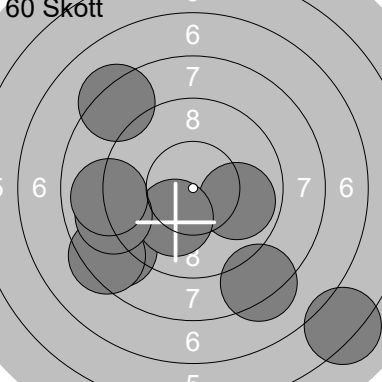
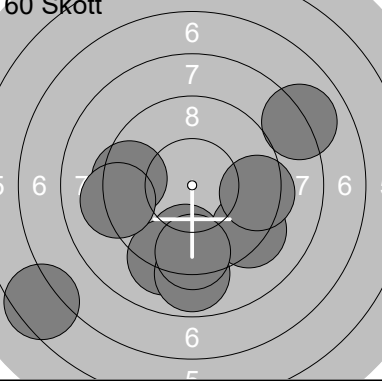
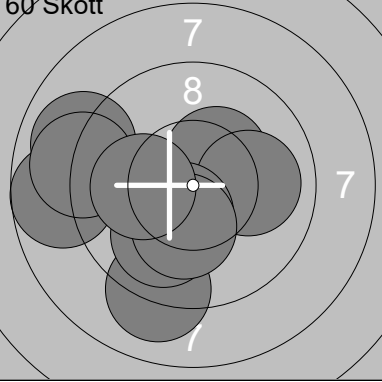
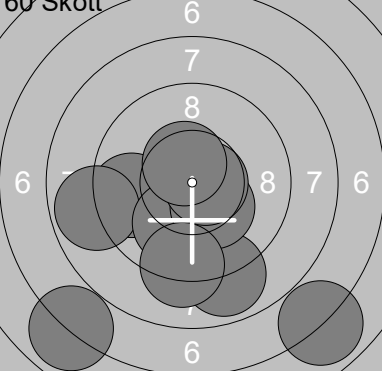
Skjutlag 3	Tavla 26	Anton Lind			
Ramselefors		Skoga-Ekshärad		15S	Vä
04.11.2018		Vindelnskyttet 2018		Ramselefors SKF	
Prov 	1: 9.1 ↓ 2: 8.4 ↓↓ 3: 9.7 ↓↓ 4: 9.2 → 5: 8.5 ↓↓ 6: 9.5 ↓ 7: 9.7 ← 8: 8.0 ↓ 9: 8.4 ← 10: 7.6 ←	Prov 	11: 9.8 ↓ 12: 9.3 ← 13: 9.0 ↓ 14: 10.3x ↑ 15: 9.5 ↓ 16: 7.8 ↓ 17: 9.3 → 18: 7.5 ↓ 19: 9.4 ↓ 20: 7.0 →	Serie 88.1	Serie 88.9
	Total 0.0		Total 0.0	Total 0.0	Total 0.0
Prov 	21: 7.2 ← 22: 9.6 ↓ 23: 9.5 ↓	60 Skott 	1: 8.7 ↓ 2: 10.8x → 3: 10.6x ↑ 4: 8.6 ← 5: 9.7 → 6: 10.3x → 7: 8.6 → 8: 10.3x ↓ 9: 9.7 ↗ 10: 9.7 ↗	Serie 26.3	Serie 97.0
	Total 0.0		Total 97.0	Total 0.0	Total 97.0
60 Skott 	11: 8.3 → 12: 7.7 ↓ 13: 8.2 ← 14: 10.3x ← 15: 8.9 ↓ 16: 10.0 ↑ 17: 8.1 ← 18: 8.5 ← 19: 9.3 ↓ 20: 8.5 ↓	60 Skott 	21: 9.0 ← 22: 8.3 ↓ 23: 6.2 ↓ 24: 8.7 ← 25: 8.3 ↗ 26: 9.9 → 27: 10.1 ↓ 28: 8.4 ← 29: 9.0 ← 30: 9.0 ←	Serie 87.8	Serie 86.9
	Total 184.8		Total 271.7	Total 87.8	Total 271.7
60 Skott 	31: 9.6 ↓ 32: 9.2 ↓ 33: 9.1 ↓ 34: 8.9 ↓ 35: 9.4 ↓ 36: 9.5 ← 37: 9.4 → 38: 8.0 → 39: 9.2 ← 40: 6.5 ←	60 Skott 	41: 9.1 ↓ 42: 10.0 ↓ 43: 10.4x ↗ 44: 8.7 ← 45: 10.0 → 46: 9.0 ← 47: 10.4x ↓ 48: 9.0 ← 49: 10.2x ↓ 50: 10.1 ←	Serie 88.8	Serie 96.9
	Total 360.5		Total 457.4	Total 88.8	Total 457.4
60 Skott 	51: 9.6 ← 52: 8.9 ↓ 53: 8.8 ← 54: 10.0 ↓ 55: 6.9 ↓ 56: 10.3x ↓ 57: 9.2 ↓ 58: 10.7x → 59: 10.5x ↗ 60: 6.9 ↓			Serie 91.8	
	Total 549.2			Total 549.2	

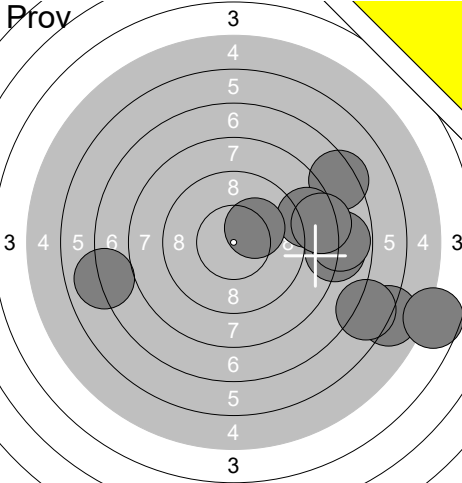
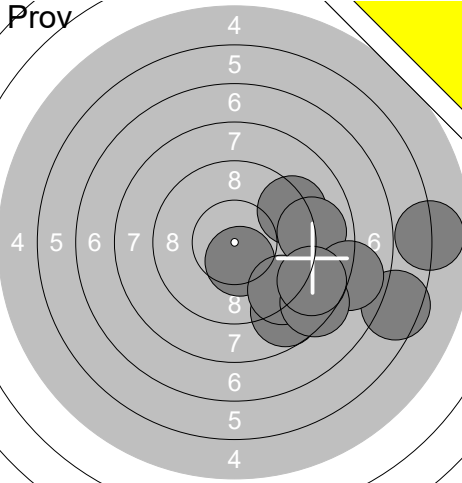
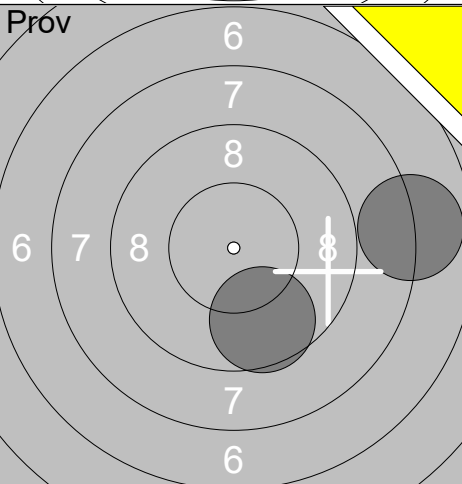
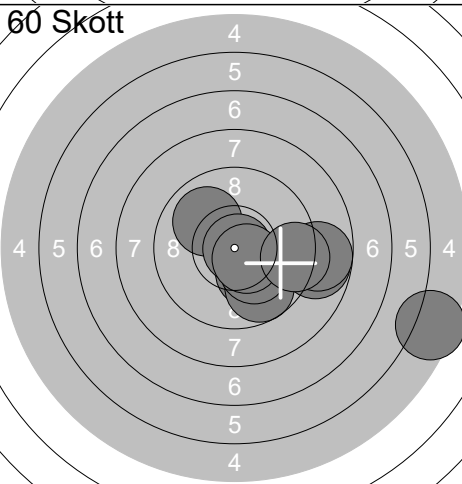
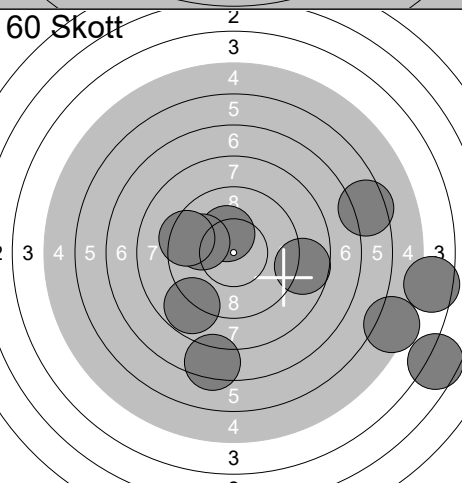
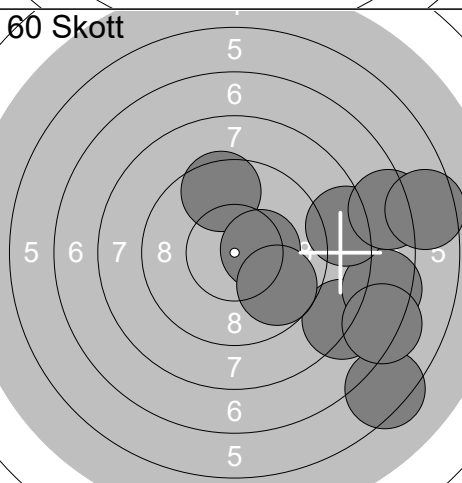
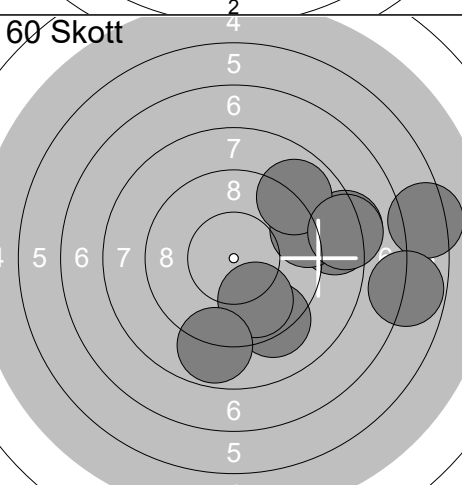

Skjutlag 3	Tavla 27	Einar Kurkkio	
Ramselefors		Gällivare	13S No
04.11.2018		Vindelnskyttet 2018	Ramselefors SKF
Prov 	1: 7.4 → 2: 8.7 → 3: 10.2x → 4: 7.9 → 5: 5.9 ↘ 6: 7.0 ← 7: 7.8 → 8: 8.3 → 9: 6.6 ↘ 10: 4.7 ↘ Serie 74.5 Total 0.0	Prov 	11: 10.4x ↓ 12: 8.7 ↓ 13: 9.2 ↓ 14: 6.5 → 15: 9.3 → 16: 8.9 → 17: 7.9 → 18: 8.4 ↓ 19: 8.7 ↓ 20: 5.9 → Serie 83.9 Total 0.0
Prov 	21: 7.9 → 22: 9.6 ↓ Serie 17.5 Total 0.0	60 Skott 	1: 10.2x ↓ 2: 8.8 → 3: 10.0 ↗ 4: 9.7 ↓ 5: 10.2x ↓ 6: 8.8 → 7: 10.9x → 8: 10.5x ↓ 9: 9.3 → 10: 5.5 ↘ Serie 93.9 Total 93.9
60 Skott 	11: 8.8 ↓ 12: 5.4 → 13: 7.4 ↓ 14: 6.5 → 15: 10.3x ↗ 16: 4.5 → 17: 8.7 → 18: 9.9 ← 19: 3.6 ↘ 20: 9.4 ← Serie 74.5 Total 168.4	60 Skott 	21: 9.5 ↑ 22: 8.1 ↓ 23: 6.4 ↓ 24: 10.4x → 25: 7.5 ↘ 26: 8.4 → 27: 9.7 ↓ 28: 7.2 ↓ 29: 7.3 → 30: 6.5 → Serie 81.0 Total 249.4
60 Skott 	31: 9.2 ↓ 32: 6.3 → 33: 6.8 → 34: 8.2 → 35: 8.5 → 36: 9.1 → 37: 9.8 ↓ 38: 8.9 ↗ 39: 8.2 → 40: 8.8 ↓ Serie 83.8 Total 333.2		

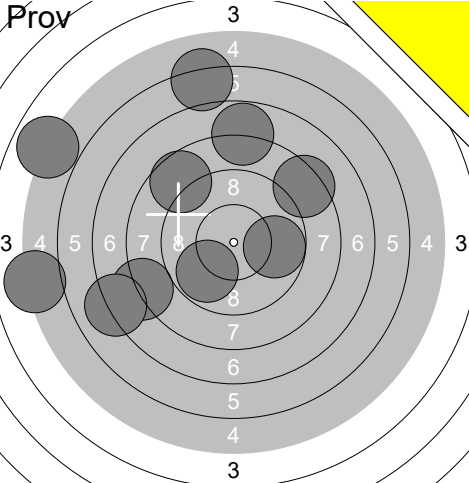
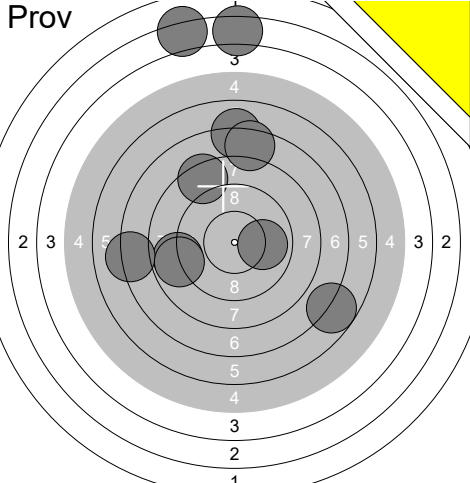
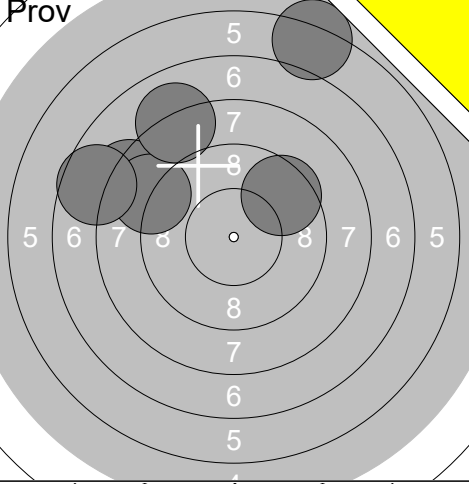
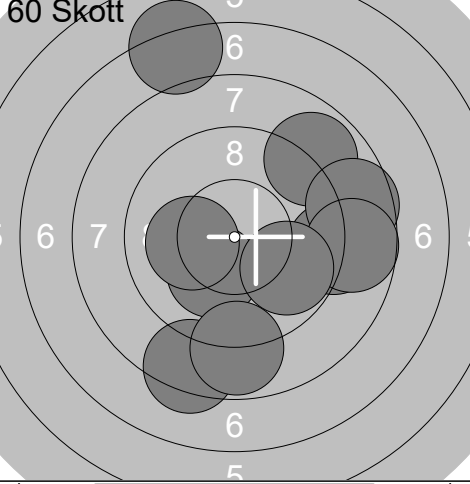
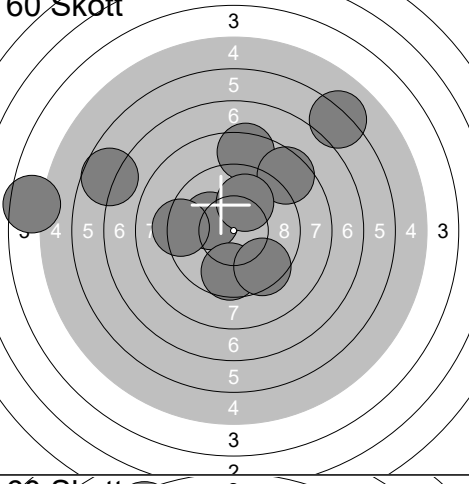
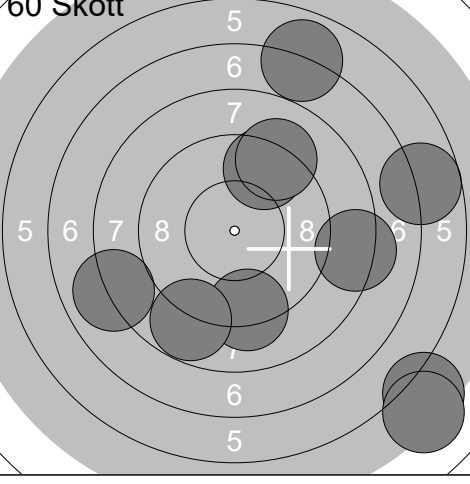
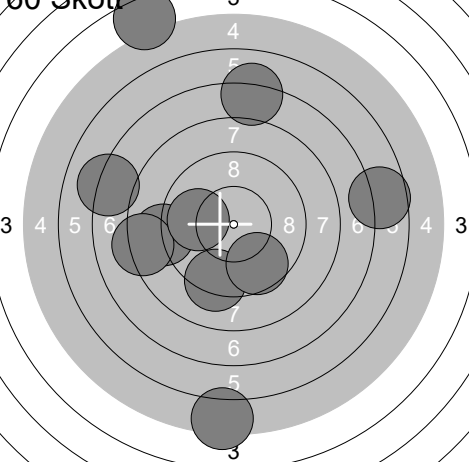
Skjutlag	Tavla	Hugo Zadewasser			
3	28	Ramselefors	Skoga-Ekshärad	15S	Vä
04.11.2018	Vindelnskyttet 2018	Ramselefors SKF			
Prov 	1: 9.6 ↗ 2: 10.1 ↗ 3: 10.6x ← 4: 9.8 ↙ 5: 8.9 ↘ 6: 9.8 → 7: 10.0 ↗ 8: 10.6x ← 9: 10.4x ↗ 10: 9.5 ↑	Prov 	11: 8.5 → 12: 10.4x ← 13: 9.5 ← 14: 10.0 ↗ 15: 10.6x ↗ 16: 10.0 → 17: 9.5 ↓ 18: 10.6x ↙		
	Serie 99.3		Serie 79.1		
	Total 0.0		Total 0.0		
60 Skott 	1: 9.9 ↗ 2: 10.0 ↗ 3: 9.4 ← 4: 10.4x ↗ 5: 9.7 ↓ 6: 10.1 ← 7: 10.0 → 8: 10.4x ↘ 9: 9.2 ↓ 10: 10.4x ←	60 Skott 	11: 9.9 ↓ 12: 9.1 → 13: 9.6 ↓ 14: 9.7 ← 15: 10.3x ↗ 16: 10.3x ↗ 17: 9.4 ↓ 18: 8.9 → 19: 9.5 ← 20: 10.3x ←		
	Serie 99.5		Serie 97.0		
	Total 99.5		Total 196.5		
60 Skott 	21: 10.5x ↗ 22: 10.1 ↑ 23: 9.0 → 24: 9.9 ↙ 25: 9.6 → 26: 9.3 ↘ 27: 10.3x ↘ 28: 9.8 → 29: 10.4x ↗ 30: 8.9 ↓	60 Skott 	31: 10.2x ↘ 32: 10.1 ↘ 33: 9.8 ↗ 34: 9.4 ↘ 35: 9.6 ← 36: 9.7 → 37: 10.0 ↘ 38: 8.9 ↘ 39: 10.0 → 40: 8.3 ↓		
	Serie 97.8		Serie 96.0		
	Total 294.3		Total 390.3		
60 Skott 	41: 9.1 → 42: 10.4x ↗ 43: 9.9 ↑ 44: 9.7 → 45: 10.2x ↗ 46: 9.9 ↓ 47: 10.2x ↗ 48: 10.4x ↘ 49: 10.2x ← 50: 9.4 ←	60 Skott 	51: 10.0 ↗ 52: 9.8 ↗ 53: 10.3x ← 54: 10.2x ↑ 55: 10.2x ↗ 56: 10.6x ↓ 57: 9.7 ← 58: 10.0 ← 59: 10.1 → 60: 10.2x ↓		
	Serie 99.4		Serie 101.1		
	Total 489.7		Total 590.8		

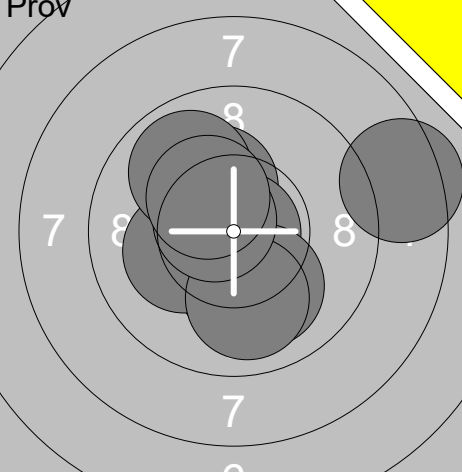
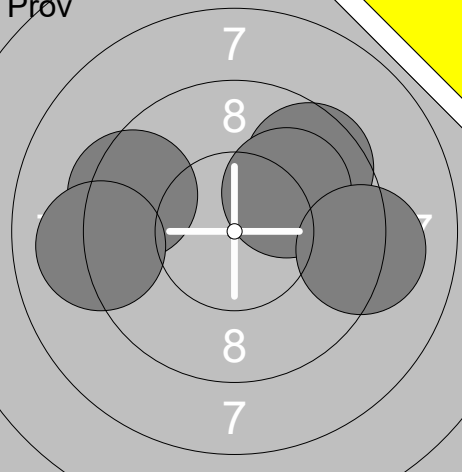
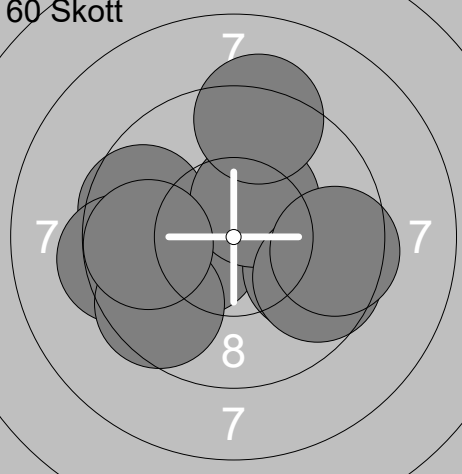
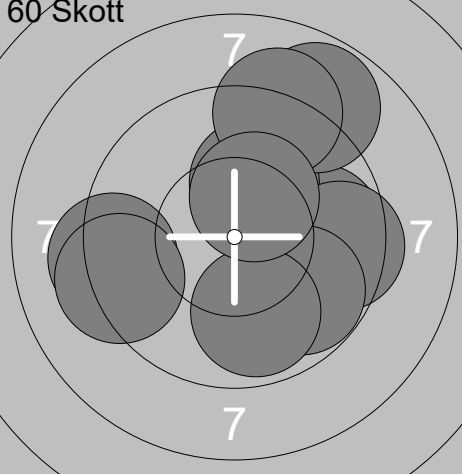
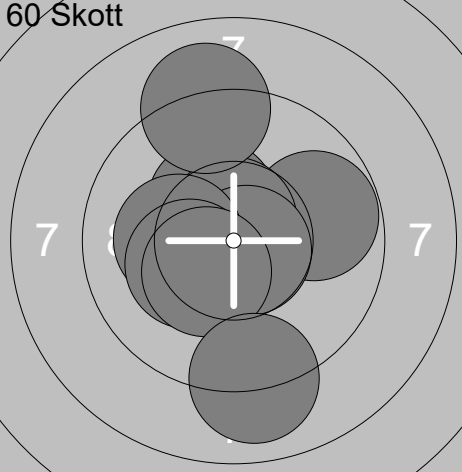
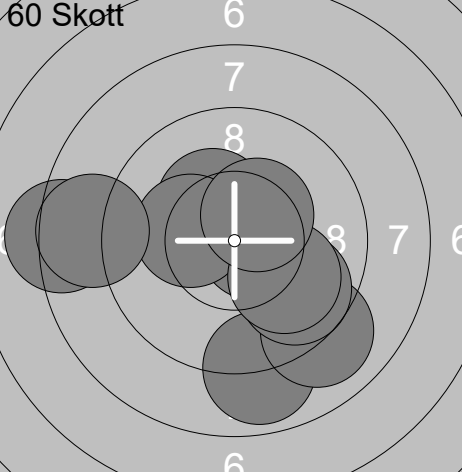
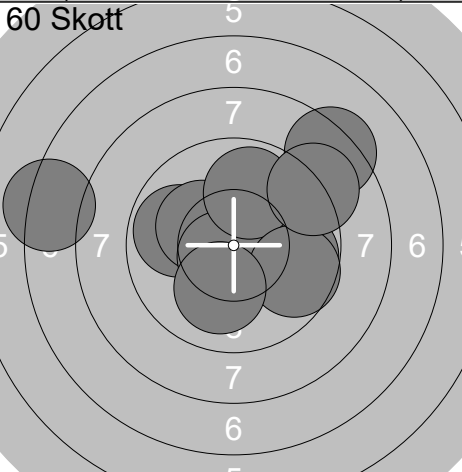
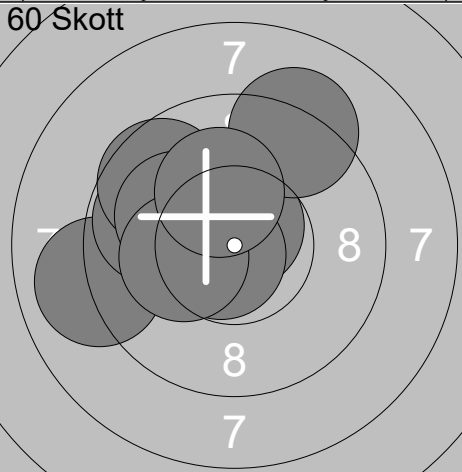
Skjuttag 3	Tavla 29	Elis Eliasson	
Ramselefors		Piteå	13S No
04.11.2018	Vindelnskyttet 2018	Ramselefors SKF	
Prov 	1: 8.0 ← 2: 6.2 ↑ 3: 9.8 → 4: 8.3 ↗ 5: 8.6 ↗ 6: 9.8 ↘ 7: 7.1 ← 8: 5.1 ← 9: 4.9 ↖ 10: 7.8 ↑ Serie 75.6 Total 0.0	Prov 	11: 3.2 ↑ 12: 7.0 ↑ 13: 8.8 ← 14: 7.2 ← 15: 3.3 ↑ 16: 8.9 ← 17: 9.9 → 18: 8.4 ↗ 19: 7.4 ↑ 20: 6.7 ↘ Serie 70.8 Total 0.0
Prov 	21: 8.3 ↖ 22: 8.8 ↖ 23: 6.2 ↑ 24: 7.7 ↖ 25: 8.1 ↗ 26: 9.5 ↗ Serie 48.6 Total 0.0	60 Skott 	1: 8.9 ↗ 2: 8.3 ↘ 3: 10.2x ↘ 4: 7.2 ↑ 5: 9.0 → 6: 8.8 ↓ 7: 8.6 → 8: 8.7 → 9: 10.1 ← 10: 9.8 ↘ Serie 89.6 Total 89.6
60 Skott 	11: 10.1 ↖ 12: 9.7 ↓ 13: 9.3 ← 14: 6.1 ↗ 15: 4.5 ← 16: 8.4 ↑ 17: 9.5 ↘ 18: 8.6 ↗ 19: 6.7 ↖ 20: 10.0 ↑ Serie 82.9 Total 172.5	60 Skott 	21: 9.5 ↑ 22: 9.2 ↓ 23: 6.9 ↑ 24: 5.5 ↘ 25: 9.1 ↗ 26: 8.0 ← 27: 8.3 → 28: 6.7 → 29: 5.2 ↘ 30: 8.8 ↓ Serie 77.2 Total 249.7
60 Skott 	31: 5.3 ↓ 32: 7.1 ↑ 33: 8.9 ← 34: 7.1 ↖ 35: 8.3 ← 36: 6.6 → 37: 9.3 ↓ 38: 9.6 ↘ 39: 9.9 ← 40: 4.4 ↗ Serie 76.5 Total 326.2		

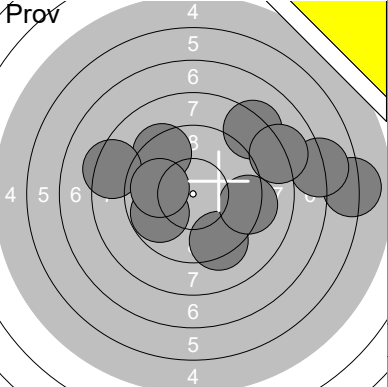
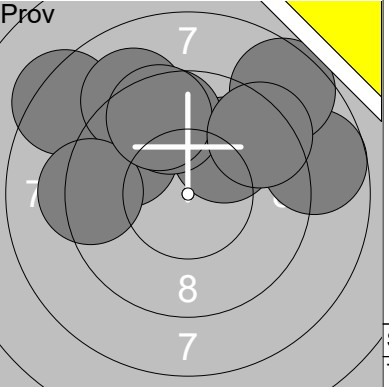
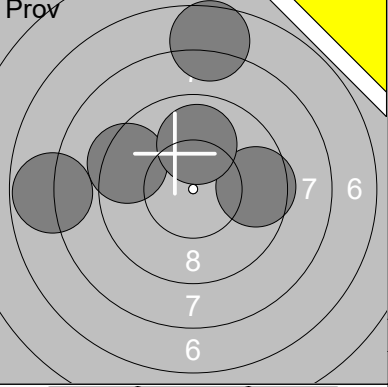
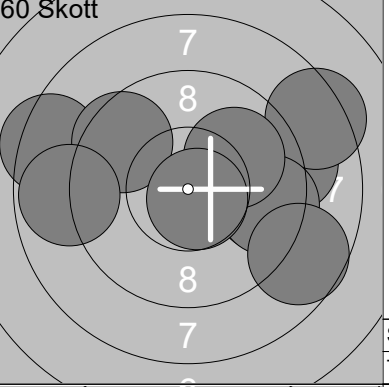
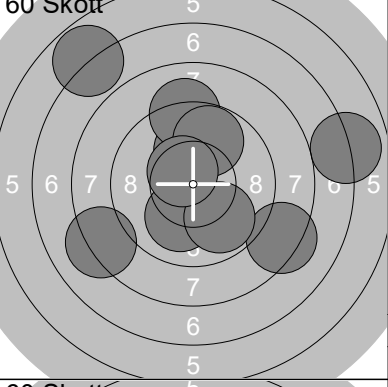
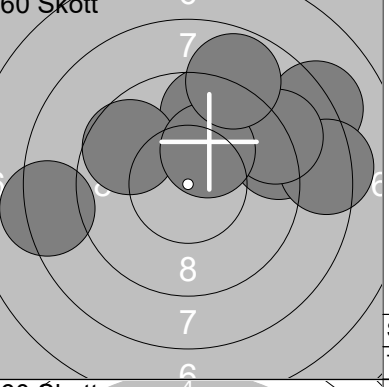
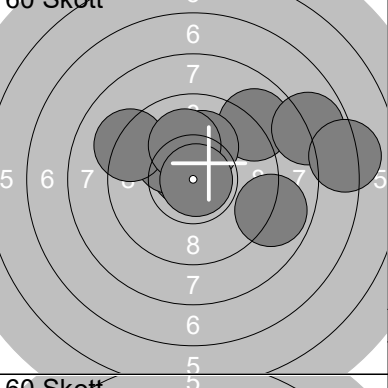
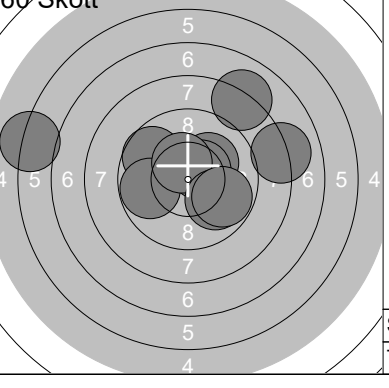
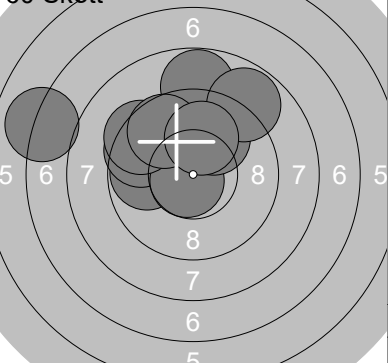
Prov 	1: 10.3x ↗ 2: 10.9x → 3: 10.3x ↓ 4: 10.1 ↓ 5: 10.2x ← 6: 9.9 ↗ 7: 10.0 ↓ 8: 8.4 → 9: 10.6x ↗ 10: 10.3x ↗ <hr/> Serie 101.0 Total 0.0	Prov 	11: 9.6 ↗ 12: 9.4 ← 13: 9.1 ← 14: 10.0 ↗ 15: 9.2 → <hr/> Serie 47.3 Total 0.0
60 Skott 	1: 10.4x ← 2: 9.6 ← 3: 9.4 ← 4: 9.8 → 5: 10.4x ↗ 6: 9.6 ← 7: 9.3 ↗ 8: 9.7 → 9: 9.8 ← 10: 9.5 → <hr/> Serie 97.5 Total 97.5	60 Skott 	11: 9.8 → 12: 10.1 ↗ 13: 9.5 → 14: 9.2 ← 15: 8.8 ↗ 16: 9.1 ↗ 17: 9.2 ← 18: 9.8 → 19: 9.9 ↓ 20: 10.3x ↗ <hr/> Serie 95.7 Total 193.2
60 Skott 	21: 9.8 → 22: 10.5x ↓ 23: 10.4x ↗ 24: 10.7x ↗ 25: 10.7x → 26: 10.2x ← 27: 9.1 ↗ 28: 10.3x ← 29: 10.4x ↓ 30: 9.0 ↓ <hr/> Serie 101.1 Total 294.3	60 Skott 	31: 10.6x → 32: 8.2 ← 33: 8.9 ↓ 34: 10.3x ↗ 35: 10.2x ← 36: 9.0 ↓ 37: 9.7 ↓ 38: 10.0 ↓ 39: 8.7 ← 40: 10.4x ↗ <hr/> Serie 96.0 Total 390.3
60 Skott 	41: 9.8 ← 42: 10.2x ↗ 43: 9.8 → 44: 8.3 ↗ 45: 10.6x ↓ 46: 7.3 ← 47: 9.9 ↗ 48: 9.7 → 49: 9.1 ↗ 50: 10.1 ↓ <hr/> Serie 94.8 Total 485.1	60 Skott 	51: 10.7x ↗ 52: 10.1 ↗ 53: 9.0 ← 54: 9.8 ← 55: 10.7x ← 56: 9.6 ↗ 57: 9.2 ↗ 58: 10.1 ← 59: 10.2x ← 60: 10.2x ↗ <hr/> Serie 99.6 Total 584.7

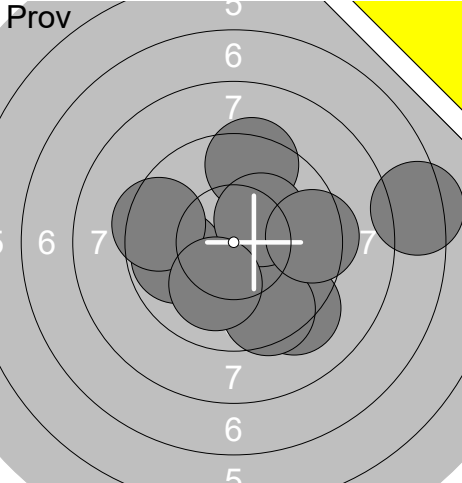
Skjutlag 3	Tavla 32	André Engström			
Ramselefors		Piteå		17S	No
04.11.2018		Vindelnskyttet 2018		Ramselefors SKF	
	1: 9.3 ↘ 2: 8.3 ↗ 3: 6.1 → 4: 9.4 ↗ 5: 7.0 → 6: 8.1 → 7: 8.4 ← 8: 9.2 → 9: 9.8 ← 10: 9.9 ← Serie 85.5 Total 0.0		11: 9.7 ↖ 12: 10.0 ↗ 13: 8.7 → 14: 8.3 ↖ 15: 9.1 ↗ 16: 9.3 ← 17: 8.6 ↗ 18: 9.7 ↑ 19: 9.6 ↑ 20: 9.4 ↗ Serie 92.4 Total 0.0		
	21: 9.4 ← 22: 7.8 ← 23: 7.6 ↑ 24: 9.5 → 25: 10.0 ↑ Serie 44.3 Total 0.0		1: 9.1 → 2: 9.6 → 3: 8.4 ↗ 4: 8.4 ← 5: 9.5 → 6: 8.7 ↘ 7: 9.5 ↗ 8: 10.0 ↗ 9: 10.7x ↘ 10: 8.8 ← Serie 92.7 Total 92.7		
	11: 7.0 → 12: 8.2 ← 13: 10.1 ↘ 14: 10.1 ↑ 15: 8.3 ↘ 16: 9.9 ↘ 17: 6.8 ↗ 18: 9.2 ↑ 19: 9.8 ↑ 20: 10.5x ↗ Serie 89.9 Total 182.6		21: 9.6 ↑ 22: 8.3 ← 23: 8.2 ↗ 24: 9.7 ↗ 25: 9.1 → 26: 8.3 → 27: 9.1 ↗ 28: 9.7 ↖ 29: 10.2x ↑ 30: 8.8 ↑ Serie 91.0 Total 273.6		
	31: 8.9 → 32: 10.7x ↗ 33: 10.2x ↗ 34: 8.9 ↗ 35: 9.2 ↖ 36: 7.9 → 37: 7.2 → 38: 10.1 ↑ 39: 10.1 ↑ 40: 10.9x → Serie 94.1 Total 367.7		41: 9.7 ↖ 42: 8.1 ↗ 43: 10.2x ↗ 44: 9.8 ← 45: 10.5x ↗ 46: 10.4x ↑ 47: 9.9 ↘ 48: 9.8 → 49: 8.1 → 50: 6.1 ← Serie 92.6 Total 460.3		
	51: 9.8 ← 52: 9.5 ↖ 53: 8.8 ↑ 54: 10.7x ↖ 55: 9.9 ↗ 56: 9.4 ↗ 57: 8.8 ↗ 58: 9.7 ↗ 59: 10.0 ↑ 60: 7.0 ← Serie 93.6 Total 553.9				

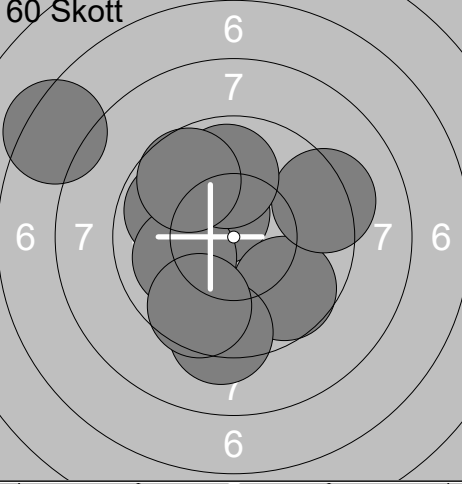
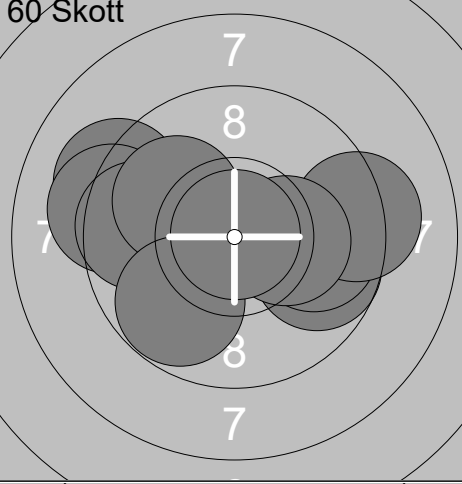
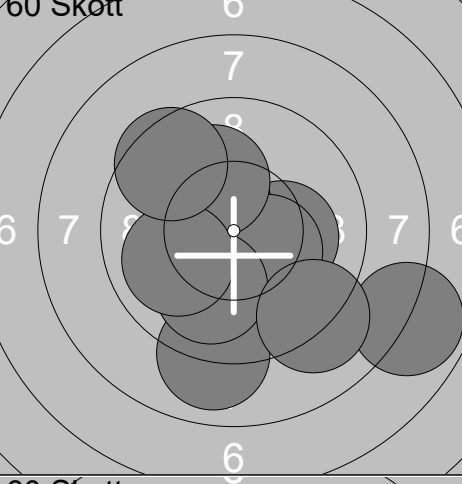
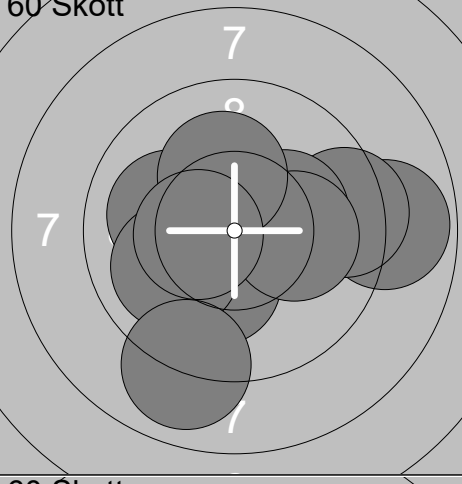
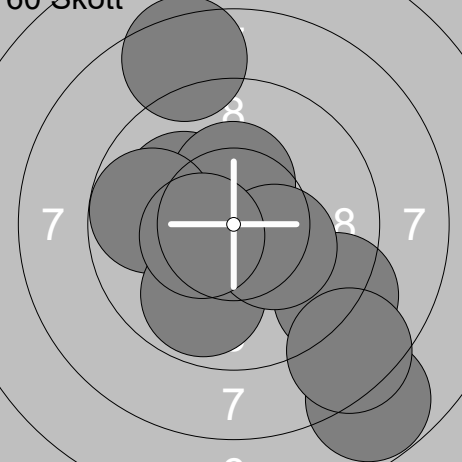
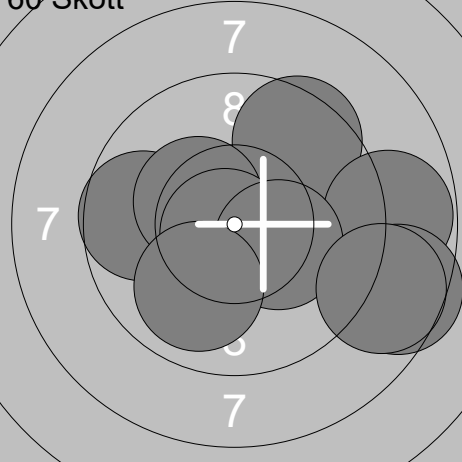
Skjuttag	Tavla	Casper Fredriksson			
3	33	Ramselefors	Ramselefors	17S	Vb
04.11.2018	Vindelnskyttet 2018	Ramselefors SKF			
Prov 	1: 10.3x ↓ 2: 9.8 ← 3: 9.2 ↓ 4: 9.5 ↖ 5: 9.4 ↑ 6: 9.5 ↓ 7: 7.4 → 8: 10.3x ↗ 9: 9.4 → 10: 10.1 ↓ Serie 94.9 Total 0.0	Prov 	11: 10.2x → 12: 9.4 ↗ 13: 10.2x ↑ Serie 29.8 Total 0.0		
60 Skott 	1: 10.5x ↗ 2: 9.7 ↓ 3: 9.9 ↖ 4: 9.3 ↓ 5: 10.0 ← 6: 9.3 → 7: 9.9 ↑ 8: 9.6 ↓ 9: 9.7 ↗ 10: 7.4 ↗ Serie 95.3 Total 95.3	60 Skott 	11: 9.7 → 12: 9.8 → 13: 9.2 → 14: 9.2 ↖ 15: 9.2 ← 16: 9.6 ← 17: 10.0 ↗ 18: 10.2x → 19: 9.8 ↓ 20: 10.9x ↑ Serie 97.6 Total 192.9		
60 Skott 	21: 10.2x → 22: 10.4x ↗ 23: 9.0 ↓ 24: 10.3x ↓ 25: 10.0 ↓ 26: 10.1 ↗ 27: 7.9 ↓ 28: 10.0 ← 29: 9.5 ↗ 30: 9.1 ↓ Serie 96.5 Total 289.4	60 Skott 	31: 8.9 → 32: 9.4 → 33: 10.2x ↓ 34: 10.0 ← 35: 10.2x → 36: 10.1 → 37: 10.0 ← 38: 9.0 ↓ 39: 10.2x ↑ 40: 10.4x ← Serie 98.4 Total 387.8		
60 Skott 	41: 10.1 ↗ 42: 10.4x ↑ 43: 9.8 ← 44: 9.2 ↓ 45: 7.8 ↓ 46: 8.5 ↗ 47: 9.9 ↓ 48: 10.3x ↓ 49: 8.5 ↓ 50: 10.5x ← Serie 95.0 Total 482.8	60 Skott 	51: 10.0 ← 52: 9.5 ↗ 53: 8.8 → 54: 9.7 ← 55: 8.5 → 56: 10.4x ↖ 57: 10.8x ↖ 58: 10.3x → 59: 10.0 ↓ 60: 8.7 → Serie 96.7 Total 579.5		

Prov 	<table style="width:100%; border-collapse: collapse;"> <tr><td>1: 8.5</td><td>↗</td></tr> <tr><td>2: 7.9</td><td>↗</td></tr> <tr><td>3: 10.3x</td><td>↗</td></tr> <tr><td>4: 9.8</td><td>↗</td></tr> <tr><td>5: 10.1</td><td>↗</td></tr> <tr><td>6: 9.0</td><td>↗</td></tr> <tr><td>7: 8.2</td><td>→</td></tr> <tr><td>8: 9.4</td><td>↓</td></tr> <tr><td>9: 9.4</td><td>↓</td></tr> <tr><td>10: 9.9</td><td>↗</td></tr> <tr style="border-top: 1px solid black;"><td>Serie</td><td style="text-align: right;">92.5</td></tr> <tr><td>Total</td><td style="text-align: right;">0.0</td></tr> </table>	1: 8.5	↗	2: 7.9	↗	3: 10.3x	↗	4: 9.8	↗	5: 10.1	↗	6: 9.0	↗	7: 8.2	→	8: 9.4	↓	9: 9.4	↓	10: 9.9	↗	Serie	92.5	Total	0.0	Prov 	<table style="width:100%; border-collapse: collapse;"> <tr><td>11: 9.4</td><td>→</td></tr> <tr><td>12: 10.0</td><td>↗</td></tr> <tr><td>13: 10.5x</td><td>←</td></tr> <tr><td>14: 10.4x</td><td>→</td></tr> <tr><td>15: 10.1</td><td>←</td></tr> <tr><td>16: 10.4x</td><td>→</td></tr> <tr style="border-top: 1px solid black;"><td>Serie</td><td style="text-align: right;">60.8</td></tr> <tr><td>Total</td><td style="text-align: right;">0.0</td></tr> </table>	11: 9.4	→	12: 10.0	↗	13: 10.5x	←	14: 10.4x	→	15: 10.1	←	16: 10.4x	→	Serie	60.8	Total	0.0								
1: 8.5	↗																																																		
2: 7.9	↗																																																		
3: 10.3x	↗																																																		
4: 9.8	↗																																																		
5: 10.1	↗																																																		
6: 9.0	↗																																																		
7: 8.2	→																																																		
8: 9.4	↓																																																		
9: 9.4	↓																																																		
10: 9.9	↗																																																		
Serie	92.5																																																		
Total	0.0																																																		
11: 9.4	→																																																		
12: 10.0	↗																																																		
13: 10.5x	←																																																		
14: 10.4x	→																																																		
15: 10.1	←																																																		
16: 10.4x	→																																																		
Serie	60.8																																																		
Total	0.0																																																		
60 Skott 	<table style="width:100%; border-collapse: collapse;"> <tr><td>1: 10.4x</td><td>↓</td></tr> <tr><td>2: 10.3x</td><td>←</td></tr> <tr><td>3: 10.8x</td><td>↓</td></tr> <tr><td>4: 10.1</td><td>←</td></tr> <tr><td>5: 9.6</td><td>←</td></tr> <tr><td>6: 10.8x</td><td>←</td></tr> <tr><td>7: 10.1</td><td>↗</td></tr> <tr><td>8: 10.2x</td><td>↗</td></tr> <tr><td>9: 8.6</td><td>↗</td></tr> <tr><td>10: 10.5x</td><td>↘</td></tr> <tr style="border-top: 1px solid black;"><td>Serie</td><td style="text-align: right;">101.4</td></tr> <tr><td>Total</td><td style="text-align: right;">101.4</td></tr> </table>	1: 10.4x	↓	2: 10.3x	←	3: 10.8x	↓	4: 10.1	←	5: 9.6	←	6: 10.8x	←	7: 10.1	↗	8: 10.2x	↗	9: 8.6	↗	10: 10.5x	↘	Serie	101.4	Total	101.4	60 Skott 	<table style="width:100%; border-collapse: collapse;"> <tr><td>11: 10.4x</td><td>→</td></tr> <tr><td>12: 10.4x</td><td>↗</td></tr> <tr><td>13: 9.3</td><td>←</td></tr> <tr><td>14: 9.6</td><td>→</td></tr> <tr><td>15: 10.1</td><td>→</td></tr> <tr><td>16: 10.6x</td><td>→</td></tr> <tr><td>17: 9.2</td><td>←</td></tr> <tr><td>18: 10.5x</td><td>↗</td></tr> <tr><td>19: 9.3</td><td>←</td></tr> <tr><td>20: 8.9</td><td>→</td></tr> <tr style="border-top: 1px solid black;"><td>Serie</td><td style="text-align: right;">98.3</td></tr> <tr><td>Total</td><td style="text-align: right;">199.7</td></tr> </table>	11: 10.4x	→	12: 10.4x	↗	13: 9.3	←	14: 9.6	→	15: 10.1	→	16: 10.6x	→	17: 9.2	←	18: 10.5x	↗	19: 9.3	←	20: 8.9	→	Serie	98.3	Total	199.7
1: 10.4x	↓																																																		
2: 10.3x	←																																																		
3: 10.8x	↓																																																		
4: 10.1	←																																																		
5: 9.6	←																																																		
6: 10.8x	←																																																		
7: 10.1	↗																																																		
8: 10.2x	↗																																																		
9: 8.6	↗																																																		
10: 10.5x	↘																																																		
Serie	101.4																																																		
Total	101.4																																																		
11: 10.4x	→																																																		
12: 10.4x	↗																																																		
13: 9.3	←																																																		
14: 9.6	→																																																		
15: 10.1	→																																																		
16: 10.6x	→																																																		
17: 9.2	←																																																		
18: 10.5x	↗																																																		
19: 9.3	←																																																		
20: 8.9	→																																																		
Serie	98.3																																																		
Total	199.7																																																		
60 Skott 	<table style="width:100%; border-collapse: collapse;"> <tr><td>21: 9.9</td><td>←</td></tr> <tr><td>22: 10.5x</td><td>←</td></tr> <tr><td>23: 9.3</td><td>→</td></tr> <tr><td>24: 9.8</td><td>→</td></tr> <tr><td>25: 10.9x</td><td>↘</td></tr> <tr><td>26: 9.5</td><td>←</td></tr> <tr><td>27: 10.4x</td><td>↓</td></tr> <tr><td>28: 10.0</td><td>←</td></tr> <tr><td>29: 10.6x</td><td>↓</td></tr> <tr><td>30: 9.4</td><td>→</td></tr> <tr style="border-top: 1px solid black;"><td>Serie</td><td style="text-align: right;">100.3</td></tr> <tr><td>Total</td><td style="text-align: right;">300.0</td></tr> </table>	21: 9.9	←	22: 10.5x	←	23: 9.3	→	24: 9.8	→	25: 10.9x	↘	26: 9.5	←	27: 10.4x	↓	28: 10.0	←	29: 10.6x	↓	30: 9.4	→	Serie	100.3	Total	300.0	60 Skott 	<table style="width:100%; border-collapse: collapse;"> <tr><td>31: 9.7</td><td>↘</td></tr> <tr><td>32: 9.9</td><td>→</td></tr> <tr><td>33: 9.5</td><td>→</td></tr> <tr><td>34: 10.4x</td><td>↓</td></tr> <tr><td>35: 10.8x</td><td>↘</td></tr> <tr><td>36: 10.5x</td><td>↓</td></tr> <tr><td>37: 10.4x</td><td>↗</td></tr> <tr><td>38: 10.2x</td><td>→</td></tr> <tr><td>39: 9.4</td><td>←</td></tr> <tr><td>40: 10.1</td><td>↓</td></tr> <tr style="border-top: 1px solid black;"><td>Serie</td><td style="text-align: right;">100.9</td></tr> <tr><td>Total</td><td style="text-align: right;">400.9</td></tr> </table>	31: 9.7	↘	32: 9.9	→	33: 9.5	→	34: 10.4x	↓	35: 10.8x	↘	36: 10.5x	↓	37: 10.4x	↗	38: 10.2x	→	39: 9.4	←	40: 10.1	↓	Serie	100.9	Total	400.9
21: 9.9	←																																																		
22: 10.5x	←																																																		
23: 9.3	→																																																		
24: 9.8	→																																																		
25: 10.9x	↘																																																		
26: 9.5	←																																																		
27: 10.4x	↓																																																		
28: 10.0	←																																																		
29: 10.6x	↓																																																		
30: 9.4	→																																																		
Serie	100.3																																																		
Total	300.0																																																		
31: 9.7	↘																																																		
32: 9.9	→																																																		
33: 9.5	→																																																		
34: 10.4x	↓																																																		
35: 10.8x	↘																																																		
36: 10.5x	↓																																																		
37: 10.4x	↗																																																		
38: 10.2x	→																																																		
39: 9.4	←																																																		
40: 10.1	↓																																																		
Serie	100.9																																																		
Total	400.9																																																		
60 Skott 	<table style="width:100%; border-collapse: collapse;"> <tr><td>41: 9.4</td><td>↗</td></tr> <tr><td>42: 8.9</td><td>←</td></tr> <tr><td>43: 9.7</td><td>↗</td></tr> <tr><td>44: 9.4</td><td>←</td></tr> <tr><td>45: 9.0</td><td>←</td></tr> <tr><td>46: 9.2</td><td>↗</td></tr> <tr><td>47: 9.7</td><td>↗</td></tr> <tr><td>48: 10.1</td><td>→</td></tr> <tr><td>49: 10.6x</td><td>↗</td></tr> <tr><td>50: 9.1</td><td>←</td></tr> <tr style="border-top: 1px solid black;"><td>Serie</td><td style="text-align: right;">95.1</td></tr> <tr><td>Total</td><td style="text-align: right;">496.0</td></tr> </table>	41: 9.4	↗	42: 8.9	←	43: 9.7	↗	44: 9.4	←	45: 9.0	←	46: 9.2	↗	47: 9.7	↗	48: 10.1	→	49: 10.6x	↗	50: 9.1	←	Serie	95.1	Total	496.0	60 Skott 	<table style="width:100%; border-collapse: collapse;"> <tr><td>51: 9.5</td><td>↗</td></tr> <tr><td>52: 10.1</td><td>→</td></tr> <tr><td>53: 9.8</td><td>→</td></tr> <tr><td>54: 8.2</td><td>←</td></tr> <tr><td>55: 10.2x</td><td>←</td></tr> <tr><td>56: 9.6</td><td>↗</td></tr> <tr><td>57: 9.3</td><td>↗</td></tr> <tr><td>58: 9.8</td><td>→</td></tr> <tr><td>59: 10.0</td><td>↗</td></tr> <tr><td>60: 9.6</td><td>↗</td></tr> <tr style="border-top: 1px solid black;"><td>Serie</td><td style="text-align: right;">96.1</td></tr> <tr><td>Total</td><td style="text-align: right;">592.1</td></tr> </table>	51: 9.5	↗	52: 10.1	→	53: 9.8	→	54: 8.2	←	55: 10.2x	←	56: 9.6	↗	57: 9.3	↗	58: 9.8	→	59: 10.0	↗	60: 9.6	↗	Serie	96.1	Total	592.1
41: 9.4	↗																																																		
42: 8.9	←																																																		
43: 9.7	↗																																																		
44: 9.4	←																																																		
45: 9.0	←																																																		
46: 9.2	↗																																																		
47: 9.7	↗																																																		
48: 10.1	→																																																		
49: 10.6x	↗																																																		
50: 9.1	←																																																		
Serie	95.1																																																		
Total	496.0																																																		
51: 9.5	↗																																																		
52: 10.1	→																																																		
53: 9.8	→																																																		
54: 8.2	←																																																		
55: 10.2x	←																																																		
56: 9.6	↗																																																		
57: 9.3	↗																																																		
58: 9.8	→																																																		
59: 10.0	↗																																																		
60: 9.6	↗																																																		
Serie	96.1																																																		
Total	592.1																																																		

Skjuttlag	Tavla	Mats Österlund			
3	36	Ramselefors	Ramselefors	Vet	Vb
04.11.2018	Vindelnskyttet 2018	Ramselefors SKF			
Prov 	1: 9.6 ↘ 2: 9.1 ↘ 3: 7.6 ↗ 4: 9.3 ↗ 5: 8.9 ↘ 6: 8.4 ↙ 7: 9.6 ↗ 8: 7.5 ↘ 9: 9.6 ↗ 10: 9.3 ↖	Prov 	11: 9.8 ↗ 12: 10.0 ↗ 13: 9.7 ↘ 14: 8.0 → 15: 10.5x ↖ 16: 8.5 ↗ 17: 10.4x → 18: 10.6x ↙ 19: 8.9 ↘ 20: 9.8 →	Serie 88.9 Total 0.0	Serie 96.2 Total 0.0
60 Skott 	1: 8.6 ↘ 2: 9.5 ↘ 3: 10.5x ↗ 4: 9.4 ↗ 5: 9.8 ↗ 6: 9.8 ↗ 7: 8.2 → 8: 10.1 → 9: 9.9 ↘ 10: 9.4 ↘	60 Skott 	11: 9.3 ↘ 12: 10.2x ↘ 13: 8.5 → 14: 8.9 ↘ 15: 8.0 ↗ 16: 8.4 → 17: 9.9 ↘ 18: 7.6 ↘ 19: 9.6 ↘ 20: 9.8 →	Serie 95.2 Total 95.2	Serie 90.2 Total 185.4
60 Skott 	21: 9.4 ↘ 22: 9.1 ↖ 23: 9.3 ↘ 24: 10.4x ↗ 25: 9.0 ↗ 26: 10.1 ↘ 27: 9.3 ↗ 28: 10.4x ↘ 29: 10.8x ↗ 30: 8.8 ↖	60 Skott 	31: 9.4 ↗ 32: 8.3 ↖ 33: 9.3 ↘ 34: 10.3x ↘ 35: 9.5 ↘ 36: 9.2 ↗ 37: 8.7 ↗ 38: 9.5 ↗ 39: 10.3x ↗ 40: 8.9 ↘	Serie 96.6 Total 282.0	Serie 93.4 Total 375.4
60 Skott 	41: 9.3 ↘ 42: 8.8 ↗ 43: 9.7 ↘ 44: 9.4 ↖ 45: 7.8 ↗ 46: 9.9 ↗ 47: 8.4 ↘ 48: 9.8 ↘ 49: 9.9 ↖ 50: 9.7 ↗	60 Skott 	51: 10.8x ↘ 52: 8.2 ↗ 53: 10.8x ↗ 54: 10.7x → 55: 9.3 ↖ 56: 10.5x ↘ 57: 10.3x ↗ 58: 9.6 ↗ 59: 9.5 ↘ 60: 9.9 ↗	Serie 92.7 Total 468.1	Serie 99.6 Total 567.7

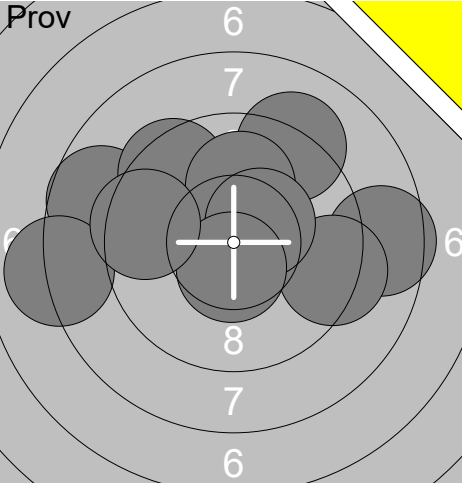
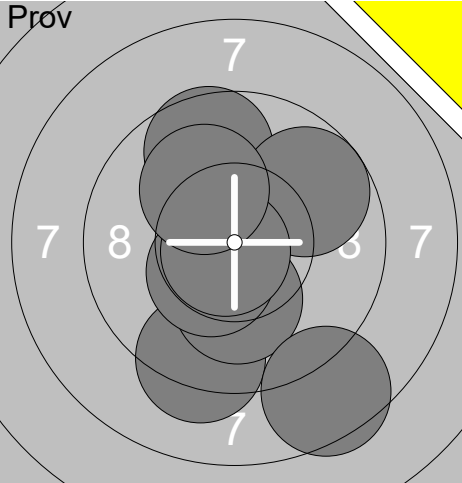
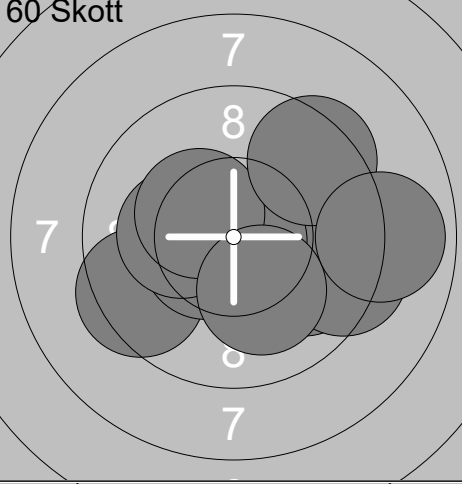
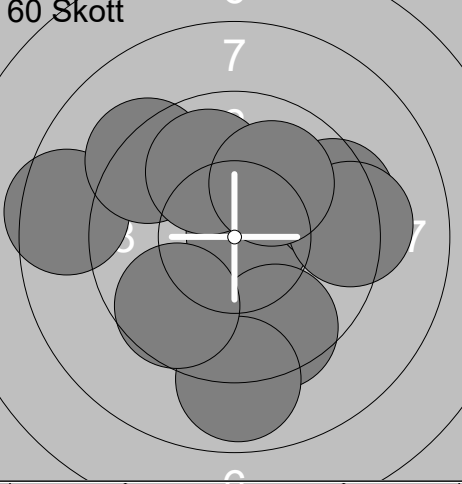
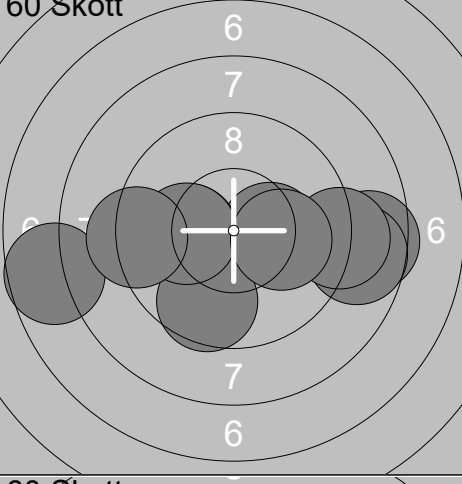
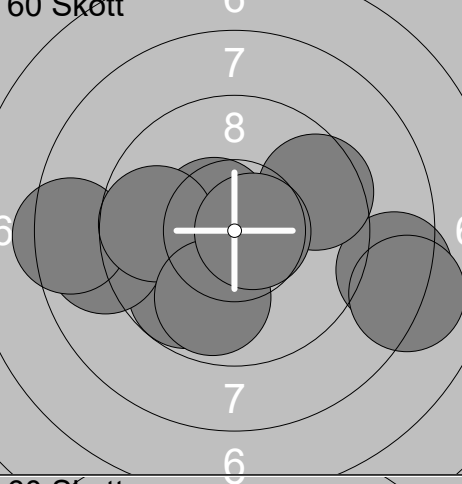
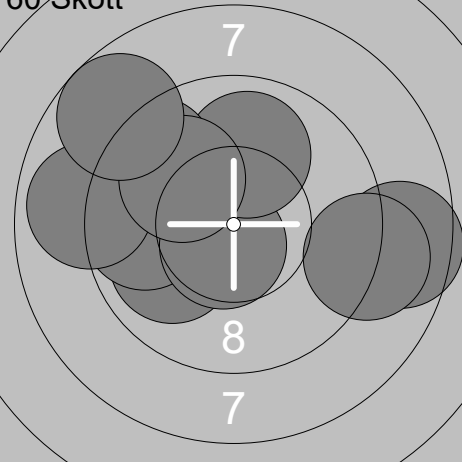
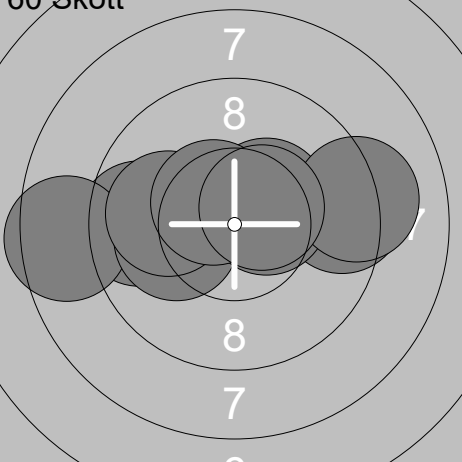
Skjutlag	Tavla	Anders Andersson			
3	37	Ramselefors	Skoga-Ekshärad	Vet	Vä
04.11.2018	Vindelnskyttet 2018	Ramselefors SKF			
Prov 	1: 9.1 ↗	Prov 	11: 9.3 ↓		
	2: 8.7 ↖		12: 9.6 ↗		
	3: 8.5 →		13: 10.2x ↓		
	4: 9.5 ↗		14: 9.7 ↗		
	5: 10.0 ↑		15: 10.4x ↓		
	6: 9.3 →		16: 8.5 ↓		
	7: 8.1 ↖		17: 10.8x ↖		
	8: 10.4x ↗		18: 10.1 ↗		
	9: 10.5x ↓				
	10: 9.5 ↖				
	Serie 93.6		Serie 78.6		
	Total 0.0		Total 0.0		
60 Skott 	1: 9.5 ↖	60 Skott 	11: 8.5 ↖		
	2: 10.5x ↖		12: 10.7x →		
	3: 9.9 ↘		13: 9.5 ↓		
	4: 9.3 ↘		14: 9.3 ↗		
	5: 10.8x ↘		15: 9.9 ↗		
	6: 10.2x ↖		16: 9.4 →		
	7: 10.4x ↗		17: 8.9 ↓		
	8: 9.4 ↗		18: 9.7 ↖		
	9: 10.1 ↓		19: 9.3 →		
	10: 8.9 →		20: 10.0 ↗		
	Serie 99.0		Serie 95.2		
	Total 99.0		Total 194.2		
60 Skott 	21: 10.3x →	60 Skott 	31: 8.4 →		
	22: 10.1 ↖		32: 9.6 →		
	23: 7.7 ↖		33: 10.6x ↖		
	24: 8.5 →		34: 9.8 ↓		
	25: 9.6 ↓		35: 8.9 ↖		
	26: 10.1 ↖		36: 8.1 →		
	27: 9.2 ↖		37: 8.4 ↖		
	28: 8.7 →		38: 9.7 ↖		
	29: 9.1 →		39: 9.9 ↓		
	30: 10.1 →		40: 10.7x →		
	Serie 93.4		Serie 94.1		
	Total 287.6		Total 381.7		
60 Skott 	41: 9.9 ↖	60 Skott 	51: 9.6 ↖		
	42: 9.7 ↖		52: 9.4 →		
	43: 10.6x ↓		53: 8.5 ↖		
	44: 9.9 ↗		54: 10.4x ↗		
	45: 9.5 ↗		55: 10.1 ↖		
	46: 8.6 →		56: 10.5x →		
	47: 8.9 ↖		57: 10.0 ↖		
	48: 10.0 ↗		58: 10.5x ↗		
	49: 8.7 ↗		59: 9.2 →		
	50: 9.0 ↘		60: 10.5x ↗		
	Serie 94.8		Serie 98.7		
	Total 476.5		Total 575.2		

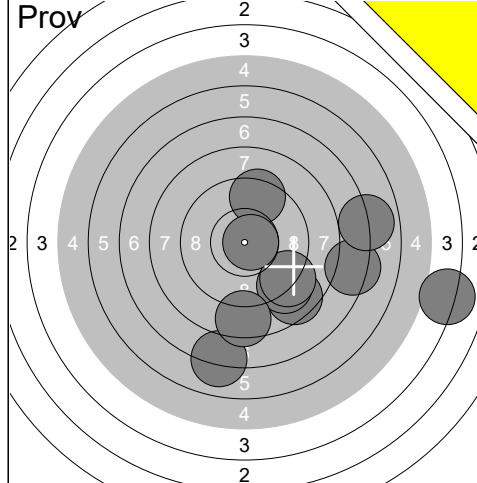

1:	7.3	→
2:	6.9	→
3:	8.5	↓
4:	9.0	↓
5:	7.1	↓
6:	8.4	↓
7:	9.4	↑
8:	9.1	↓
9:	10.8x	→
10:	4.1	→
Serie		80.6
Total		0.0

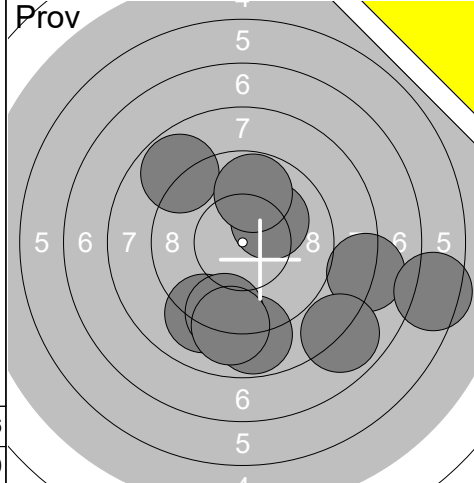

11:	8.8	↓
12:	10.2x	↗
13:	8.1	→
14:	9.1	↓
15:	6.4	→
16:	7.9	↓
17:	9.3	↓
18:	8.8	↗
19:	9.8	↑
20:	9.0	↓
Serie		87.4
Total		0.0

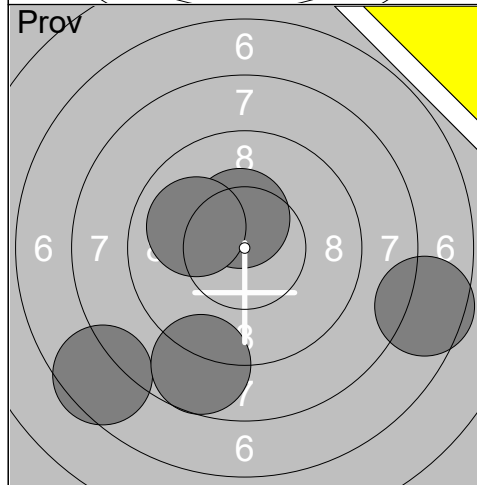

21:	7.5	↙
22:	10.4x	↑
23:	10.0	↖
24:	8.7	↓
25:	7.6	→
Serie		44.2
Total		0.0

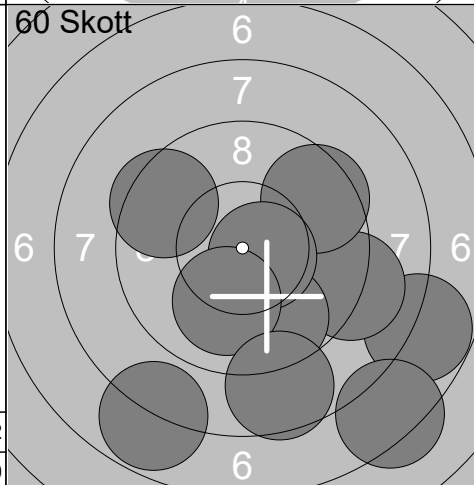

1:	9.5	↖
2:	7.8	→
3:	9.1	→
4:	9.5	↗
5:	9.7	↓
6:	10.6x	→
7:	10.0	↓
8:	7.8	↓
9:	8.6	↓
10:	7.3	↓
Serie		89.9
Total		89.9

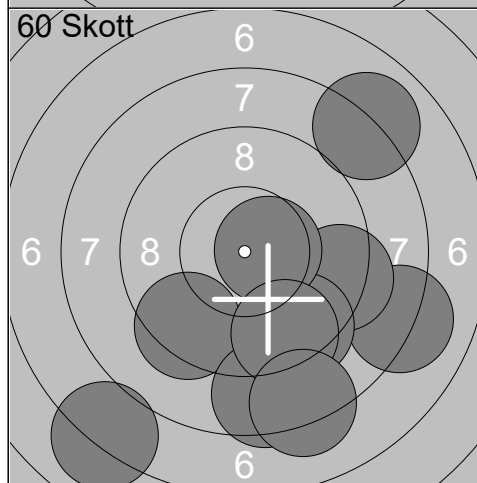

11:	9.4	↙
12:	8.1	→
13:	8.0	↗
14:	9.3	→
15:	9.4	↓
16:	10.6x	→
17:	7.1	↙
18:	8.5	↓
19:	9.4	↓
20:	8.2	↓
Serie		88.0
Total		177.9

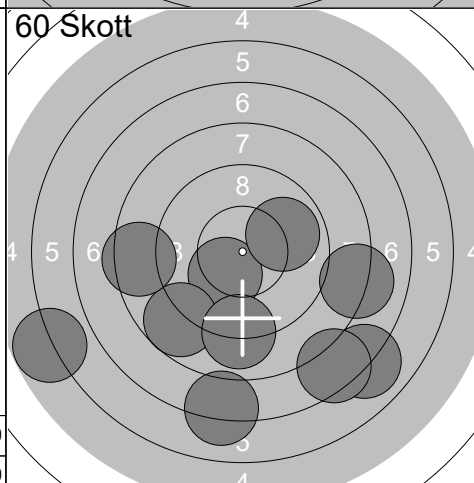

21:	10.3x	↙
22:	8.7	↙
23:	7.0	↙
24:	7.4	↙
25:	8.1	→
26:	8.4	←
27:	9.0	↓
28:	7.1	↓
29:	5.8	↙
30:	9.9	↗
Serie		81.7
Total		259.6

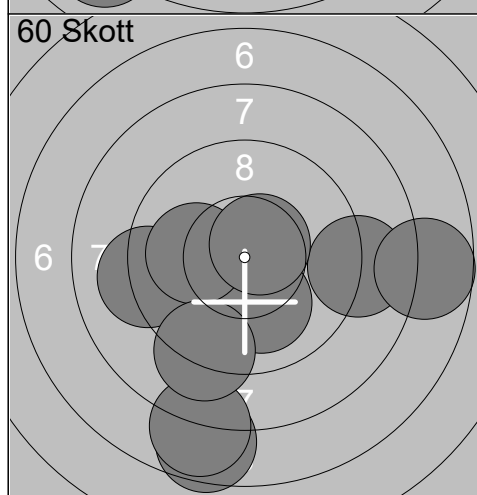

31:	10.0	↙
32:	8.9	→
33:	9.2	←
34:	10.1	↓
35:	7.6	↓
36:	7.8	↓
37:	10.1	←
38:	10.6x	↗
39:	9.1	↓
40:	7.7	→
Serie		91.1
Total		350.7

Skjutlag 3	Tavla 40	Lennart Westermark	
Ramselefors	Drängsmark	Sitt	Vb
04.11.2018	Vindelnskyttet 2018	Ramselefors SKF	
Prov 	1: 10.3x ↗ 2: 9.0 ↑ 3: 9.9 ↑ 4: 10.2x → 5: 10.3x ↗ 6: 9.8 ↘ 7: 9.9 ← 8: 10.5x ↗ 9: 10.6x ↖ 10: 10.0 ↘ Serie 96 Total 0	40 Skott 	1: 10.6x ↘ 2: 10.4x ↘ 3: 10.6x ↘ 4: 10.0 ↑ 5: 10.4x ↘ 6: 10.5x → 7: 9.2 → 8: 10.0 → 9: 10.3x ↘ 10: 9.9 ↑ Serie 98 Total 98
40 Skott 	11: 9.0 ↘ 12: 10.3x ↘ 13: 10.0 → 14: 10.2x ↘ 15: 9.9 ↘ 16: 9.3 ↗ 17: 10.1 → 18: 10.6x ↘ 19: 10.2x ↘ 20: 10.8x ↗ Serie 97 Total 195	40 Skott 	21: 10.3x ↗ 22: 9.4 → 23: 10.0 → 24: 9.9 ↘ 25: 10.3x ↘ 26: 10.0 ↖ 27: 10.5x ← 28: 10.6x ↘ 29: 9.7 ↗ 30: 10.1 ↗ Serie 97 Total 292
40 Skott 	31: 9.5 → 32: 10.4x ↖ 33: 9.8 ↑ 34: 10.4x ↑ 35: 10.6x ↘ 36: 9.9 ← 37: 10.0 ↑ 38: 10.4x ↘ 39: 10.1 ↑ 40: 10.2x ↘ Serie 97 Total 389		