

Skjuttag <b>1</b>	Tavla <b>19</b>	<b>Lia Edholm</b>	
S		Umeå	
13.01.2019		Skyttiaden 2019	Umeå skytteallians
Prov 	1: 10.2x↗ 2: 10.5x↘ 3: 10.2x↘ 4: 10.2x↗ 5: 10.6x➔	60 Skott 	1: 10.4x↘ 2: 10.7x↘ 3: 10.5x↘ 4: 10.3x↘ 5: 10.8x↘ 6: 10.3x↘ 7: 10.4x↗ 8: 9.3 ↓ 9: 10.2x↗ 10: 10.2x↗
	Serie 51.7		Serie 103.1
	Total 0.0		Total 103.1
60 Skott 	11: 10.0 ↗ 12: 10.5x↗ 13: 10.5x↘ 14: 10.3x↗ 15: 10.6x↗ 16: 10.5x↘ 17: 10.8x↘ 18: 10.3x↗ 19: 10.6x↘ 20: 10.7x↗	60 Skott 	21: 10.4x↗ 22: 10.2x↘ 23: 10.5x↗ 24: 10.7x↗ 25: 10.8x↗ 26: 10.6x↘ 27: 10.5x↘ 28: 10.6x➔ 29: 10.5x↘ 30: 10.5x↘
	Serie 104.8		Serie 105.3
	Total 207.9		Total 313.2
60 Skott 	31: 10.5x↘ 32: 10.6x➔ 33: 10.4x↘ 34: 10.6x↘ 35: 10.8x↗ 36: 10.5x↗ 37: 10.6x↗ 38: 10.4x↗ 39: 10.5x↘ 40: 10.9x↘		
	Serie 105.8		
	Total 419.0		

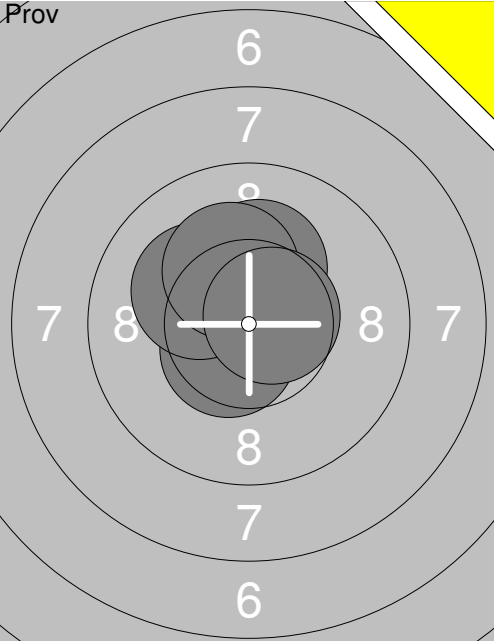
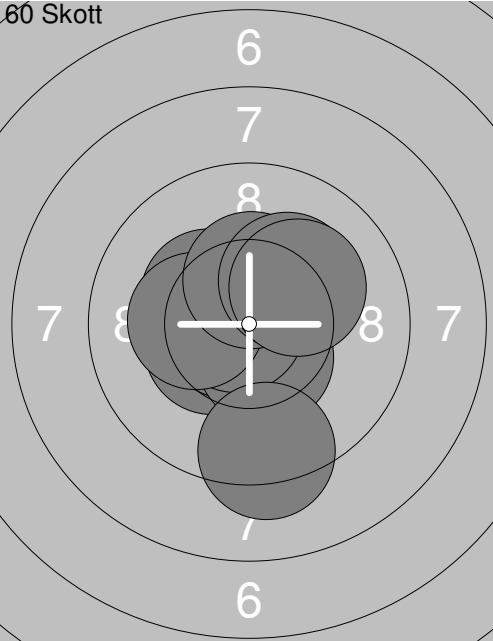
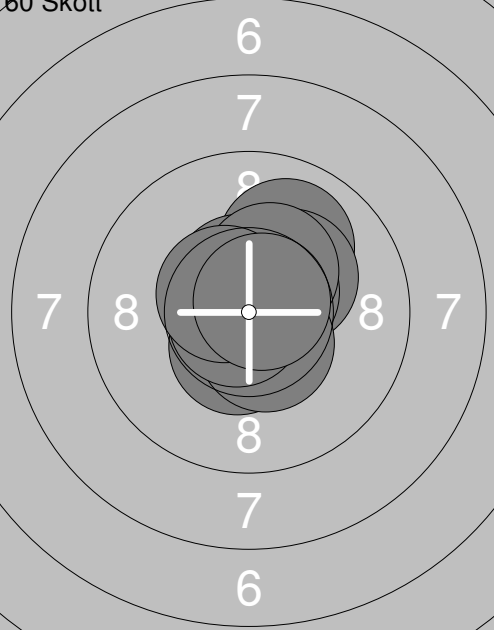
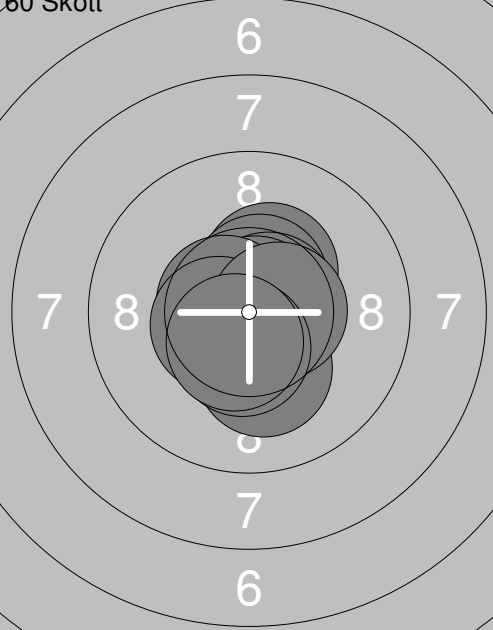
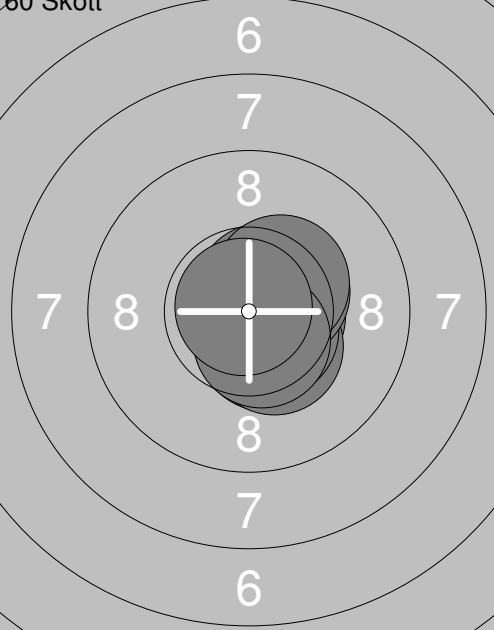
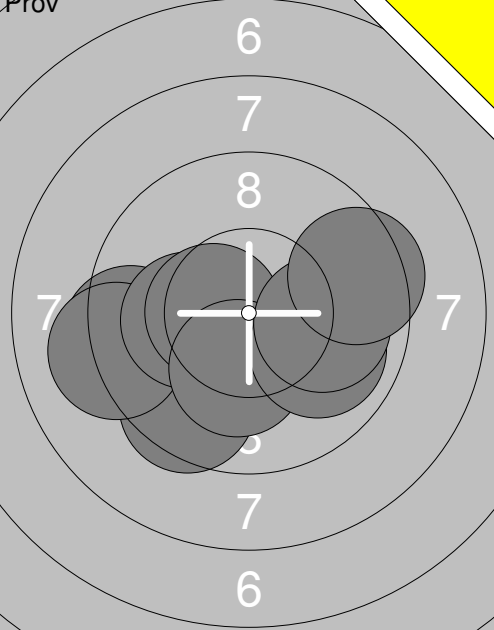
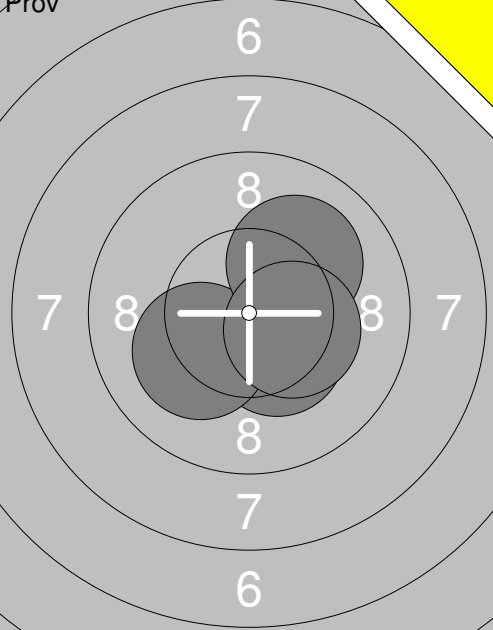
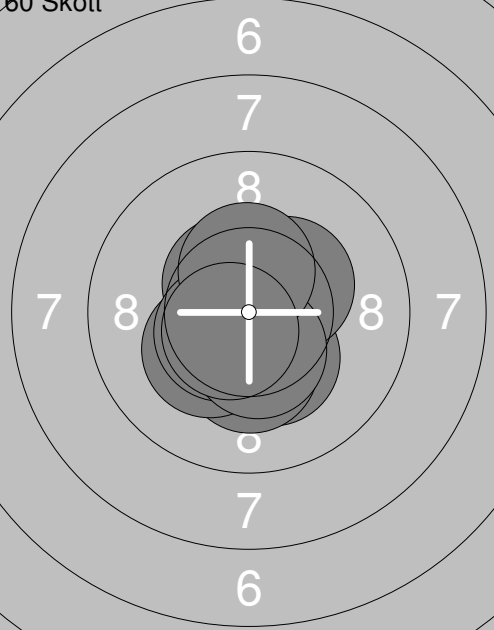
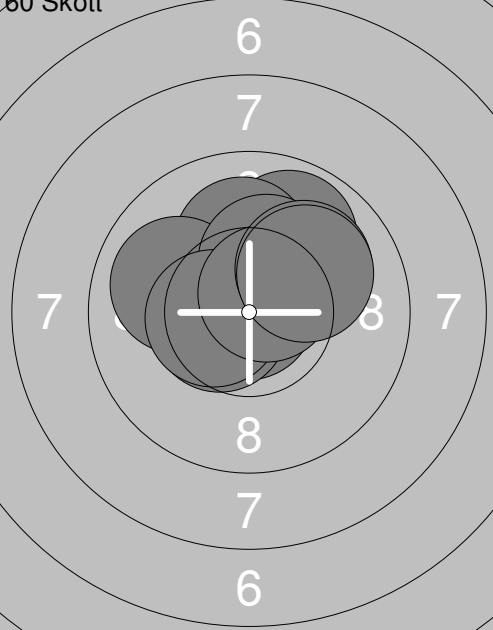
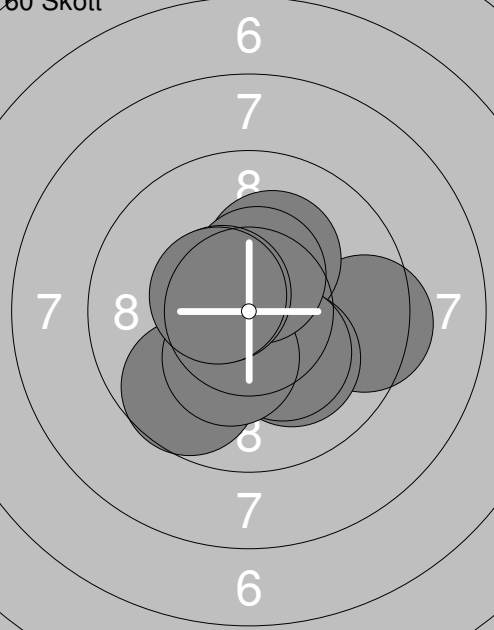
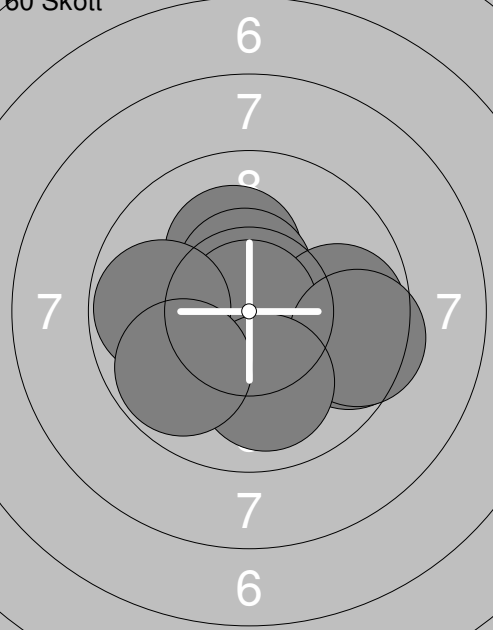
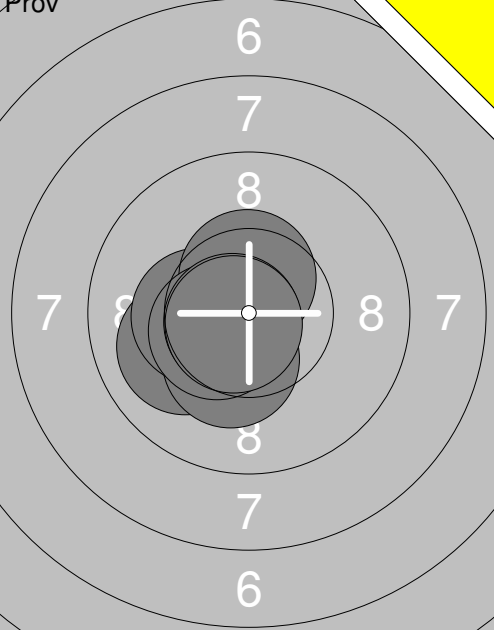
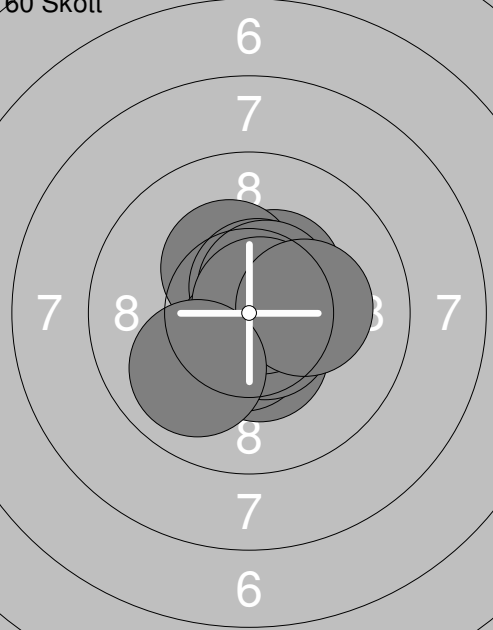
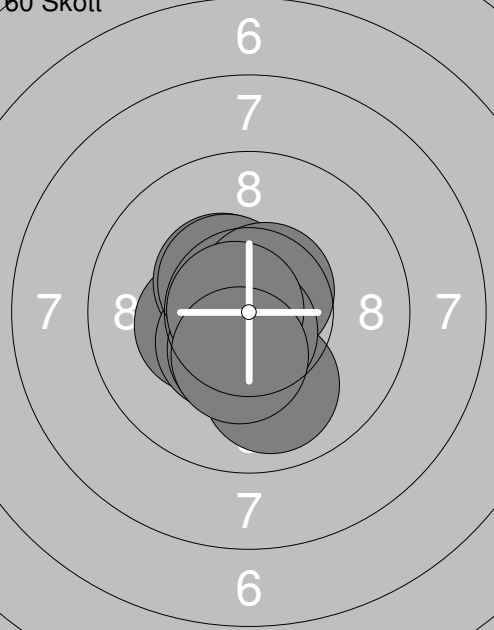
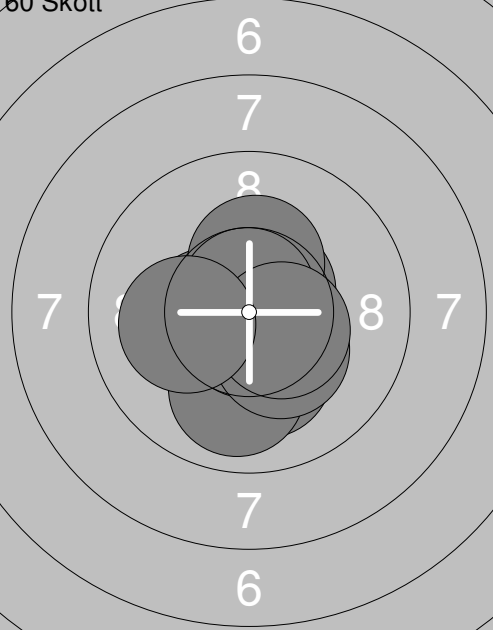
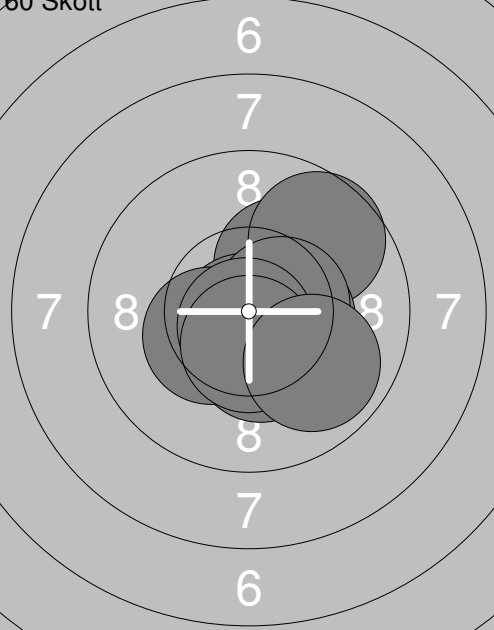
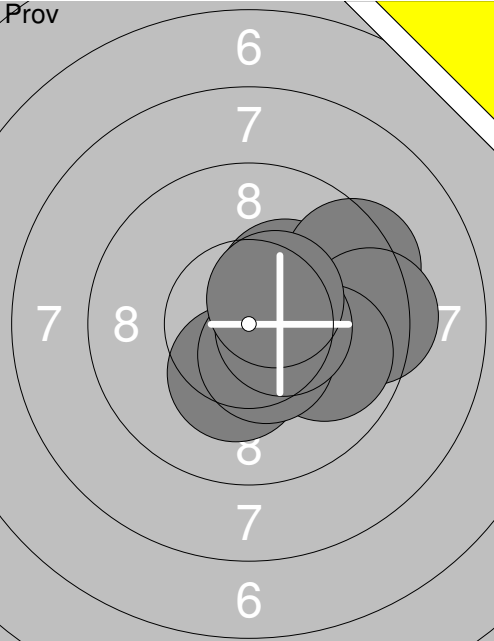
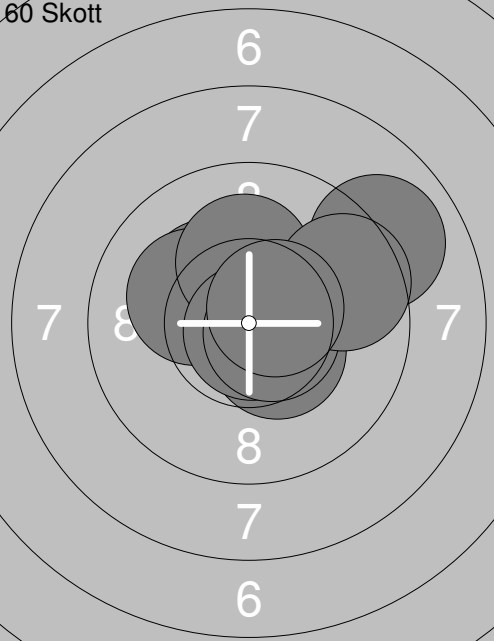
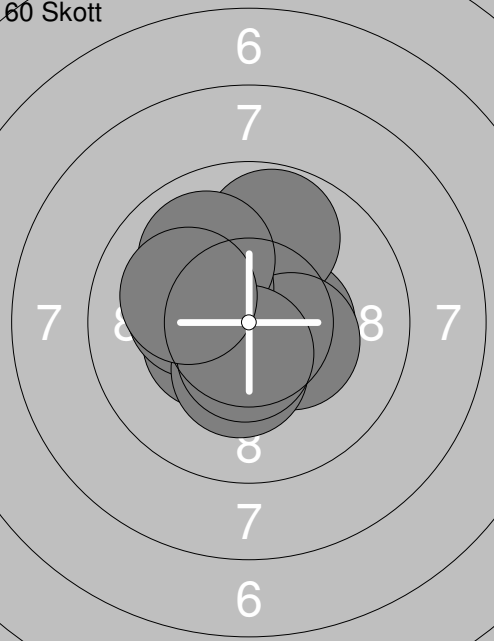

<p>Prov</p> 	<p>1: 9.4 ←</p> <p>2: 9.5 ←</p> <p>3: 9.5 ↘</p> <p>4: 9.2 ←</p> <p>5: 10.2x ←</p> <p>6: 10.5x ←</p> <p>7: 10.2x ↘</p> <p>8: 9.9 ↘</p> <p>9: 10.0 →</p> <p>10: 9.5 →</p> <p>Serie 97.9</p> <p>Total 0.0</p>	<p>Prov</p> 	<p>11: 10.4x ↘</p> <p>12: 10.2x ↘</p> <p>13: 10.1 ↗</p> <p>14: 10.3x →</p> <p>Serie 41.0</p> <p>Total 0.0</p>
<p>60 Skott</p> 	<p>1: 10.6x ↗</p> <p>2: 10.3x ↘</p> <p>3: 10.4x ↗</p> <p>4: 10.3x ↘</p> <p>5: 10.2x ↘</p> <p>6: 10.5x ↘</p> <p>7: 10.5x ↘</p> <p>8: 10.4x ↘</p> <p>9: 10.4x ↗</p> <p>10: 10.6x ↘</p> <p>Serie 104.2</p> <p>Total 104.2</p>	<p>60 Skott</p> 	<p>11: 9.9 ↗</p> <p>12: 10.1 ↑</p> <p>13: 10.9x ↘</p> <p>14: 10.0 ←</p> <p>15: 10.3x ↗</p> <p>16: 10.5x ↘</p> <p>17: 10.5x ↘</p> <p>18: 10.6x ↗</p> <p>19: 10.1 ↗</p> <p>20: 10.1 ↗</p> <p>Serie 103.0</p> <p>Total 207.2</p>
<p>60 Skott</p> 	<p>21: 9.4 →</p> <p>22: 10.2x ↗</p> <p>23: 10.1 ↘</p> <p>24: 10.8x ↗</p> <p>25: 10.3x ↘</p> <p>26: 9.7 ↘</p> <p>27: 10.3x ↘</p> <p>28: 10.5x ↗</p> <p>29: 10.5x ↘</p> <p>30: 10.5x ↘</p> <p>Serie 102.3</p> <p>Total 309.5</p>	<p>60 Skott</p> 	<p>31: 10.7x ↘</p> <p>32: 10.2x ↗</p> <p>33: 10.5x ↗</p> <p>34: 9.6 →</p> <p>35: 9.8 →</p> <p>36: 10.9x ↗</p> <p>37: 9.5 →</p> <p>38: 9.8 ←</p> <p>39: 10.0 ↘</p> <p>40: 9.8 ↘</p> <p>Serie 100.8</p> <p>Total 410.3</p>

<p>Prov</p>  <p style="text-align: center;">6 7 8 7 8 7 6</p>	<p>1: 10.0 ↙ 2: 10.3x ↘ 3: 10.3x ↙ 4: 10.5x ↗ 5: 10.5x ↘ 6: 10.7x ↘ 7: 10.7x ↘</p> <p>Serie 73.0 Total 0.0</p>	<p>60 Skott</p>  <p style="text-align: center;">6 7 8 7 8 7 6</p> <p>8: 10.4x ↘ 9: 10.4x ↗ 10: 10.6x ↗ 11: 10.6x ↘ 12: 10.6x ↗ 13: 10.8x ↗ 14: 10.2x ↘</p> <p>Serie 104.5 Total 104.5</p>
<p>60 Skott</p>  <p style="text-align: center;">6 7 8 7 8 7 6</p>	<p>11: 10.3x ↙ 12: 10.4x ↘ 13: 10.4x ↘ 14: 10.0 ↓ 15: 10.5x ↘ 16: 10.4x ↘ 17: 10.6x ↗ 18: 10.7x ↘ 19: 10.8x ↙ 20: 10.4x ↘</p> <p>Serie 104.5 Total 209.0</p>	<p>60 Skott</p>  <p style="text-align: center;">6 7 8 7 8 7 6</p> <p>21: 10.5x ↙ 22: 10.2x ↘ 23: 10.6x ↗ 24: 9.9 ↓ 25: 10.7x ↘ 26: 10.3x ↗ 27: 10.3x ↘ 28: 10.7x ↗ 29: 10.5x ↘ 30: 10.1 ←</p> <p>Serie 103.8 Total 312.8</p>
<p>60 Skott</p>  <p style="text-align: center;">6 7 8 7 8 7 6</p>	<p>31: 10.2x ↗ 32: 10.4x ↘ 33: 9.7 ↗ 34: 10.8x ↘ 35: 10.4x ↘ 36: 10.4x ➤ 37: 10.5x ➤ 38: 10.8x ↘ 39: 10.5x ↘ 40: 9.9 ↘</p> <p>Serie 103.6 Total 416.4</p>	

Skjuttag	Tavla	Tilda Rosendahl	
1	23		
S	Ramselefors		
13.01.2019	Skyttiaden 2019	Umeå skytteallians	
Prov		1: 10.3x↓ 2: 10.3x↗ 3: 10.5x↗ 4: 9.4 ↗ 5: 10.1 ➤ 6: 9.4 ➔ 7: 9.9 ➤ 8: 10.5x↓ 9: 10.5x➤ 10: 10.5x↗ Serie 101.4 Total 0.0	11: 9.6 ↗ 12: 10.3x↗ 13: 10.3x➤ 14: 9.6 ↗ 15: 10.2x↑ Serie 50.0 Total 0.0
60 Skott		1: 10.4x↘ 2: 10.3x↘ 3: 9.0 ↗ 4: 10.2x↘ 5: 10.5x↗ 6: 10.2x↑ 7: 10.8x↓ 8: 10.6x➤ 9: 9.6 ↗ 10: 10.6x↗ Serie 102.2 Total 102.2	11: 10.2x↘ 12: 10.8x↓ 13: 10.4x↑ 14: 10.9x➤ 15: 10.3x➤ 16: 10.3x↑ 17: 10.5x↘ 18: 10.4x↘ 19: 10.4x➤ 20: 10.6x➤ Serie 104.8 Total 207.0
60 Skott		21: 10.5x➤ 22: 9.8 ↗ 23: 10.4x↘ 24: 10.3x➤ 25: 10.2x↘ 26: 10.2x↘ 27: 10.0 ↖ 28: 10.3x↓ 29: 10.5x↓ 30: 10.1 ↖ Serie 102.3 Total 309.3	31: 10.0 ↗ 32: 10.6x↘ 33: 10.1 ➔ 34: 10.7x➤ 35: 10.9x↘ 36: 9.9 ➔ 37: 10.6x↗ 38: 10.3x↗ 39: 10.6x↘ 40: 10.2x↗ Serie 103.9 Total 413.2

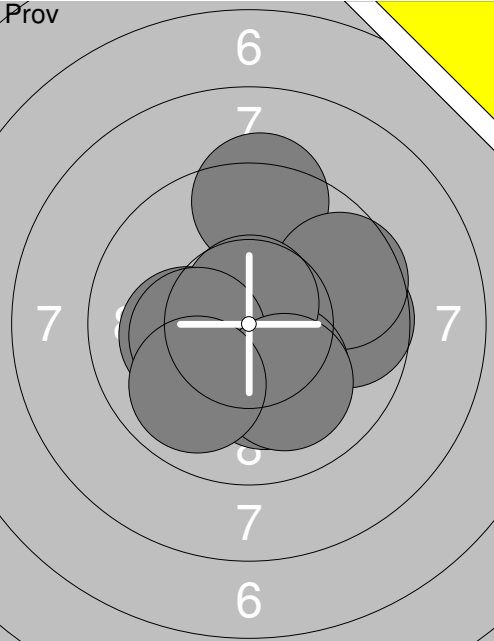
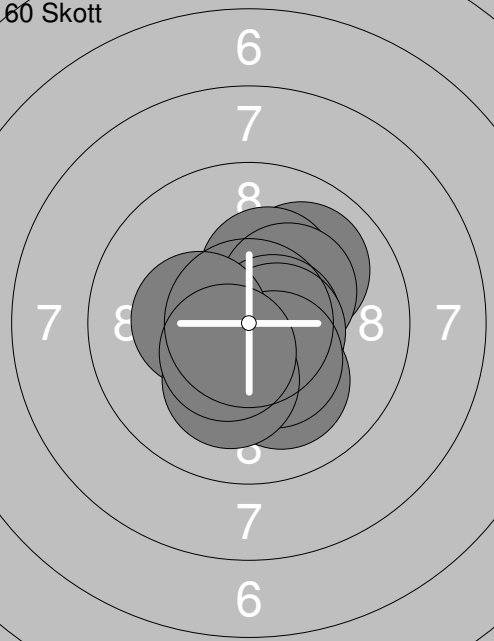
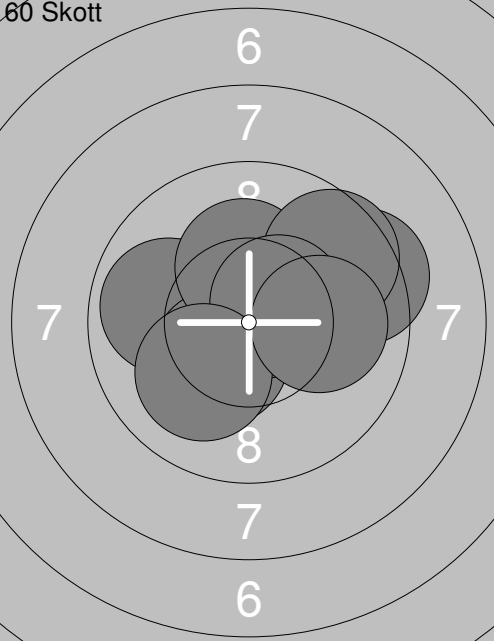
Skjutlag <b>1</b>	Tavla <b>24</b>	<b>Oscar Jonsson</b>			
<b>S</b>		<b>Vännäs</b>			
<b>13.01.2019</b>		<b>Skyttiaden 2019</b>	<b>Umeå skytteallians</b>		
<b>Pröv</b>		1: 10.4x ↗ 2: 9.5 ↓ 3: 9.0 ↓ 4: 9.3 ↖ 5: 10.2x ↓ 6: 9.8 → 7: 9.7 ↘ 8: 9.2 ↗ 9: 9.4 ↗ 10: 10.1 ↗ Serie 96.6 Total 0.0	<b>Pröv</b>		11: 9.9 ↖ 12: 10.2x ↗ 13: 9.1 ↑ 14: 9.2 ↗ 15: 9.8 ↗ 16: 9.4 ↗ 17: 9.4 ↖ 18: 9.9 ↑ 19: 9.8 ↖ 20: 10.0 ↖ Serie 96.7 Total 0.0
<b>Pröv</b>		21: 10.5x ↓ 22: 10.1 ↖ Serie 20.6 Total 0.0	<b>60 Skott</b>		1: 10.6x ↓ 2: 9.8 ↑ 3: 10.0 ↗ 4: 10.2x ↖ 5: 9.0 ↓ 6: 10.0 ↘ 7: 9.5 ↓ 8: 10.0 ↗ 9: 10.7x ↖ 10: 8.7 ↓ Serie 98.5 Total 98.5
<b>60 Skott</b>		11: 9.6 ↖ 12: 10.3x ↗ 13: 8.9 ↖ 14: 9.4 ↖ 15: 10.5x ↗ 16: 9.7 ↖ 17: 10.7x ↘ 18: 9.1 ↖ 19: 10.7x ↗ 20: 10.7x ↗ Serie 99.6 Total 198.1	<b>60 Skott</b>		21: 10.6x → 22: 9.5 ↖ 23: 10.2x ↓ 24: 9.9 ↘ 25: 10.2x ↓ 26: 10.8x ↑ 27: 8.4 ↖ 28: 10.3x → 29: 9.8 ↖ 30: 9.9 ↖ Serie 99.6 Total 297.7
<b>60 Skott</b>		31: 10.2x ↗ 32: 9.8 ↖ 33: 9.4 ↖ 34: 10.0 ↗ 35: 9.7 ↗ 36: 10.1 → 37: 8.9 ↓ 38: 10.7x ↗ 39: 9.8 ↗ 40: 10.3x ↘ Serie 98.9 Total 396.6			

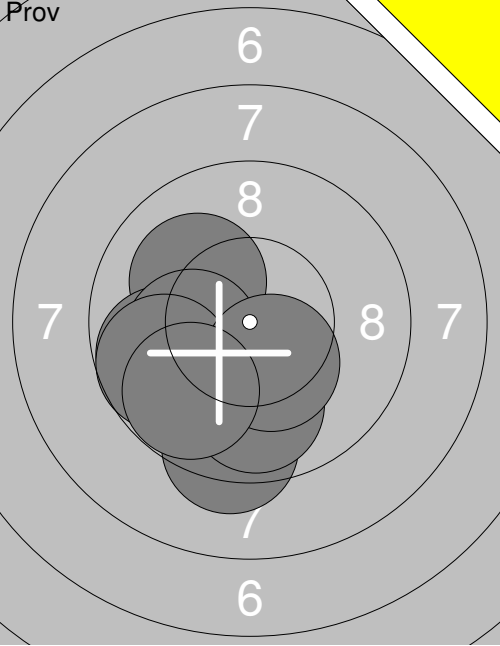
Skjutlag	Tavla	Vilhelm Lundstedt	
S		Ramselefors	
13.01.2019	Skyttiaden 2019	Umeå skytteallians	
Prov		1: 9.3 ↑ 2: 9.7 → 3: 9.6 ↗ 4: 10.2x↓ 5: 10.2x↓ 6: 10.1 ← 7: 10.7x↑ 8: 10.3x← 9: 10.1 ↓ 10: 9.9 ↙ Serie 100.1 Total 0.0	11: 9.6 ↘ 12: 10.4x↖ 13: 10.5x← Serie 30.5 Total 0.0
60 Skott		1: 10.0 ↗ 2: 10.3x↑ 3: 10.3x↗ 4: 10.6x→ 5: 10.6x→ 6: 10.1 ↓ 7: 10.4x↓ 8: 10.3x← 9: 10.2x↓ 10: 10.5x↓ Serie 103.3 Total 103.3	11: 10.8x↑ 12: 10.4x↖ 13: 10.6x↘ 14: 10.4x↓ 15: 10.5x↓ 16: 10.2x→ 17: 9.9 → 18: 10.2x← 19: 10.4x↓ 20: 10.3x↗ Serie 103.7 Total 207.0
60 Skott		21: 10.4x↖ 22: 9.9 ← 23: 10.4x↓ 24: 10.7x↗ 25: 9.4 → 26: 10.2x↑ 27: 9.6 ↗ 28: 10.5x↗ 29: 10.1 ↓ 30: 10.0 → Serie 101.2 Total 308.2	31: 10.7x↓ 32: 10.1 ↓ 33: 10.1 ↖ 34: 10.0 → 35: 10.0 ↓ 36: 10.8x↑ 37: 10.7x↖ 38: 10.0 ↑ 39: 10.0 → 40: 10.3x↑ Serie 102.7 Total 410.9

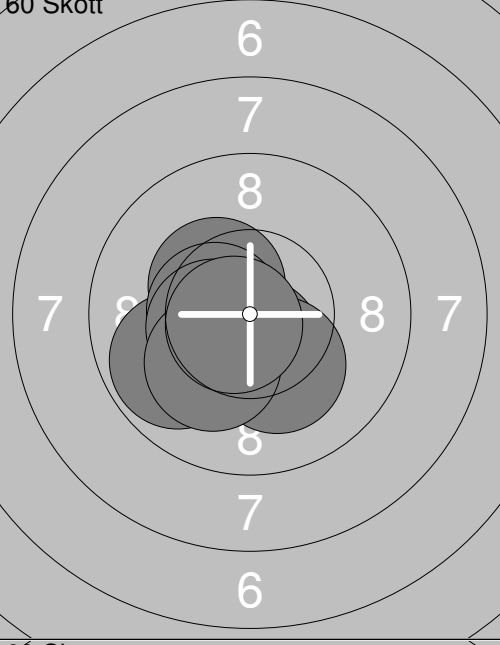
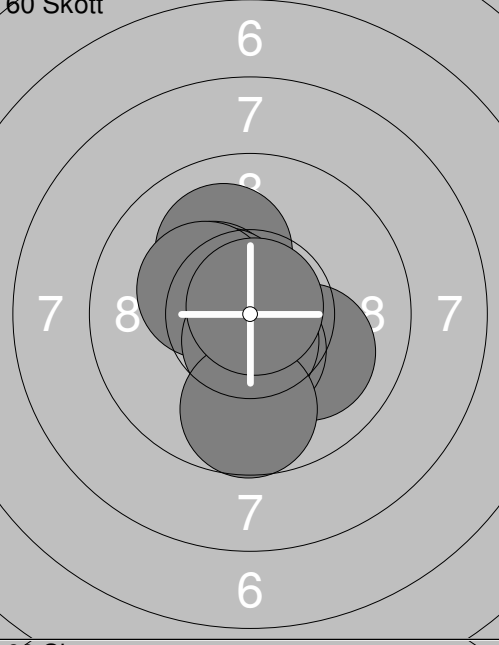
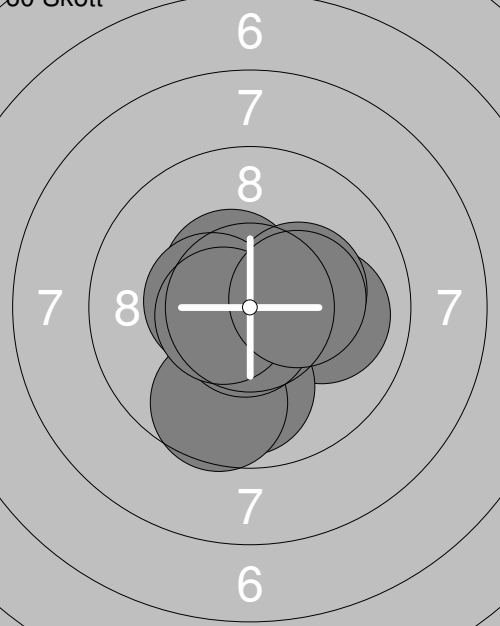
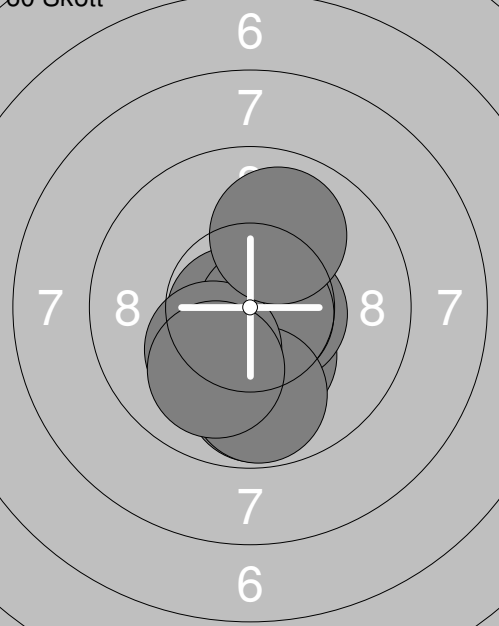
Skjuttlag	Tavla	Ebba Lundstedt	
1	27		
S	Ramselefors		
13.01.2019	Skyttiaden 2019	Umeå skytteallians	
Prov		Prov	
	1: 9.9 ↙ 2: 9.3 ↓ 3: 10.1 ↖ 4: 9.8 ← 5: 10.2x ↘ 6: 10.2x ↘ 7: 9.7 ← 8: 9.9 ↓ 9: 10.4x ↓ 10: 9.8 ↙		11: 10.6x ↓ 12: 10.4x ↓ 13: 10.1 ↓ 14: 10.0 ↓ 15: 10.3x ↓ 16: 10.3x ↘
	Serie 99.3		Serie 61.7
	Total 0.0		Total 0.0
60 Skott		60 Skott	
	1: 10.4x ↘ 2: 10.4x ↘ 3: 9.8 ↙ 4: 10.5x ↘ 5: 10.2x ↘ 6: 10.5x ↘ 7: 10.5x ↓ 8: 10.2x ↓ 9: 10.2x ↘ 10: 10.7x ↘		11: 10.4x ↘ 12: 10.1 ↘ 13: 10.1 ↗ 14: 10.4x ↘ 15: 10.5x ↓ 16: 10.5x ↘ 17: 10.3x ↘ 18: 10.6x ↓ 19: 9.7 ↓ 20: 10.8x ↗
	Serie 103.4		Serie 103.4
	Total 103.4		Total 206.8
60 Skott		60 Skott	
	21: 10.0 → 22: 9.9 ↓ 23: 9.6 ↓ 24: 10.5x ↘ 25: 10.9x ↘ 26: 10.3x → 27: 10.7x ↓ 28: 10.5x ↘ 29: 10.6x ↘ 30: 10.3x →		31: 10.3x ↓ 32: 10.6x ↓ 33: 10.6x → 34: 10.7x ↘ 35: 9.8 ↓ 36: 10.7x → 37: 9.8 ↓ 38: 10.2x ↘ 39: 10.0 ↓ 40: 9.9 ↗
	Serie 103.3		Serie 102.6
	Total 310.1		Total 412.7

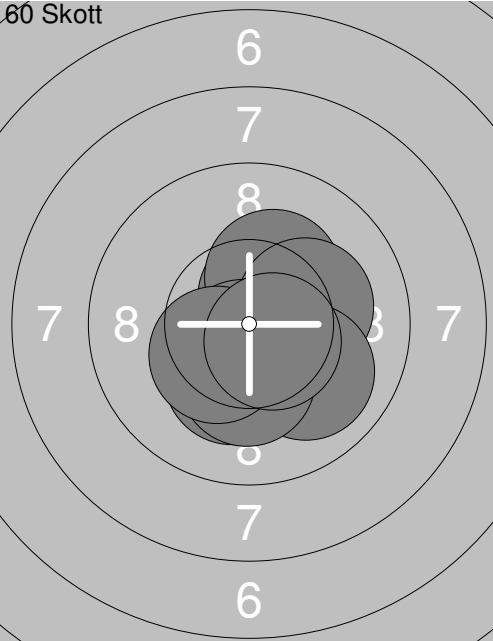
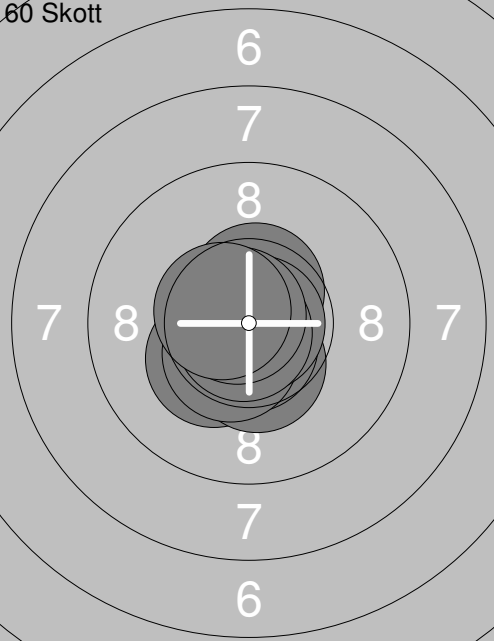
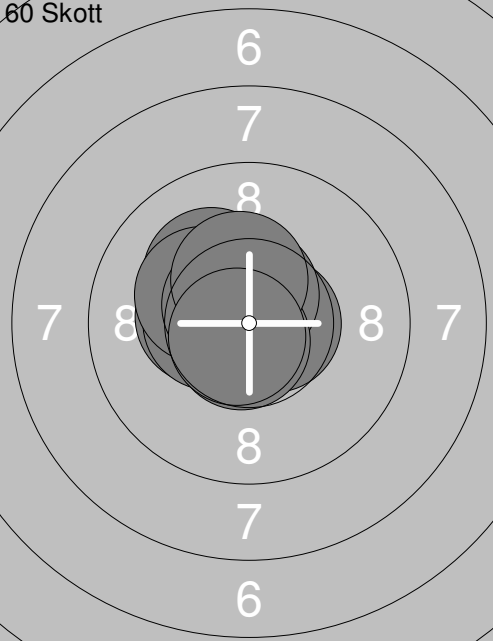
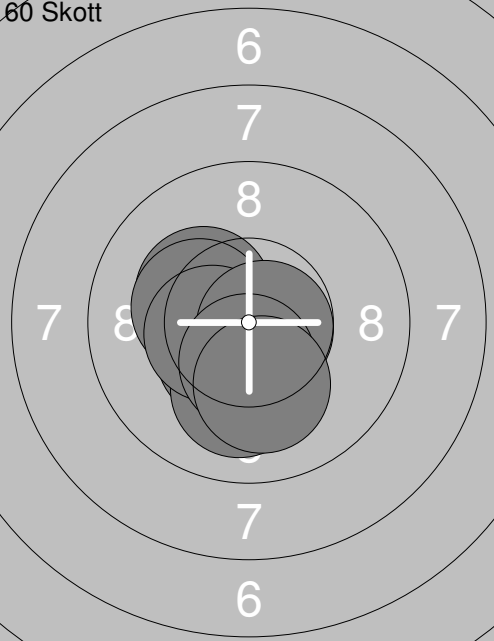
Skjutlag	Tavla	Beatrice Andersson	
1	28		
S	Ramselefors		
13.01.2019	Skyttiaden 2019	Umeå skytteallians	
Prov		60 Skott	
	1: 10.8 <del>x</del>		1: 10.6 <del>x</del> ↘
	2: 10.7 <del>x</del> ↗		2: 10.5 <del>x</del> ↗
	3: 10.4 <del>x</del> ↗		3: 10.3 <del>x</del> ↗
	4: 10.7 <del>x</del> ↘		4: 10.2 <del>x</del> ↗
			5: 10.0 ↘
			6: 10.6 <del>x</del> ↘
			7: 10.2 <del>x</del> ↘
			8: 10.3 <del>x</del> ↘
			9: 10.4 <del>x</del> ↘
			10: 10.6 <del>x</del> ↘
	Serie 42.6		Serie 103.7
	Total 0.0		Total 103.7
60 Skott		60 Skott	
	11: 10.3 <del>x</del> ↘		21: 10.2 <del>x</del> ↘
	12: 10.4 <del>x</del> ↘		22: 10.4 <del>x</del> ↘
	13: 10.7 <del>x</del> ↘		23: 10.6 <del>x</del> ↗
	14: 10.5 <del>x</del> ↘		24: 10.5 <del>x</del> ↘
	15: 10.9 <del>x</del> ↘		25: 10.6 <del>x</del> ↗
	16: 10.5 <del>x</del> ↗		26: 10.7 <del>x</del> ↘
	17: 10.8 <del>x</del> ↗		27: 10.2 <del>x</del> ↘
	18: 10.8 <del>x</del> ↘		28: 10.6 <del>x</del> ↘
	19: 10.8 <del>x</del> ↘		29: 10.4 <del>x</del> ↗
	20: 10.6 <del>x</del> ↘		30: 10.7 <del>x</del> ↘
	Serie 106.3		Serie 104.9
	Total 210.0		Total 314.9
60 Skott			
	31: 10.3 <del>x</del> ↘		
	32: 10.4 <del>x</del> ↘		
	33: 10.1 ↓		
	34: 10.7 <del>x</del> ↘		
	35: 10.5 <del>x</del> ↘		
	36: 10.3 <del>x</del> ↘		
	37: 10.5 <del>x</del> ↘		
	38: 10.7 <del>x</del> ↗		
	39: 10.4 <del>x</del> ↘		
	40: 10.1 ↓		
	Serie 104.0		
	Total 418.9		

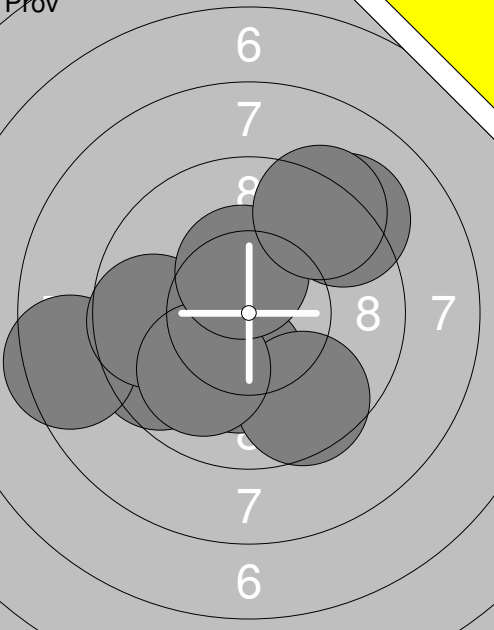
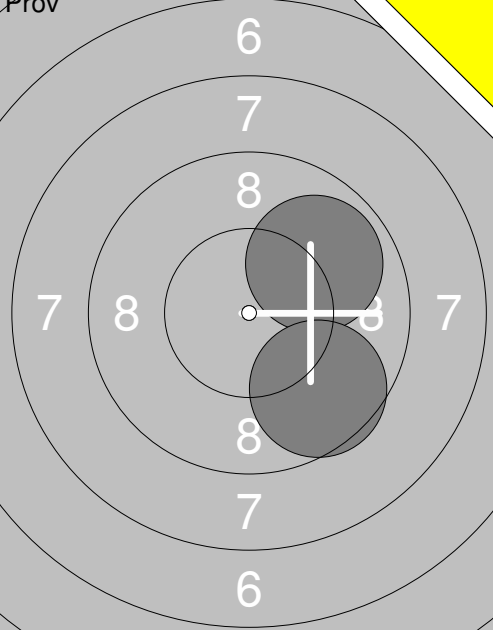
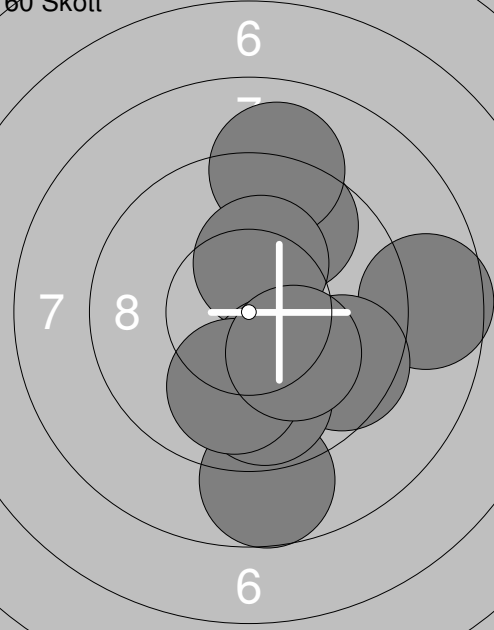
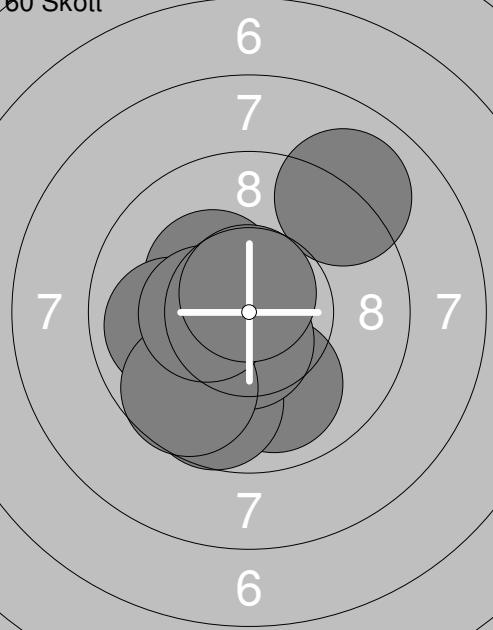
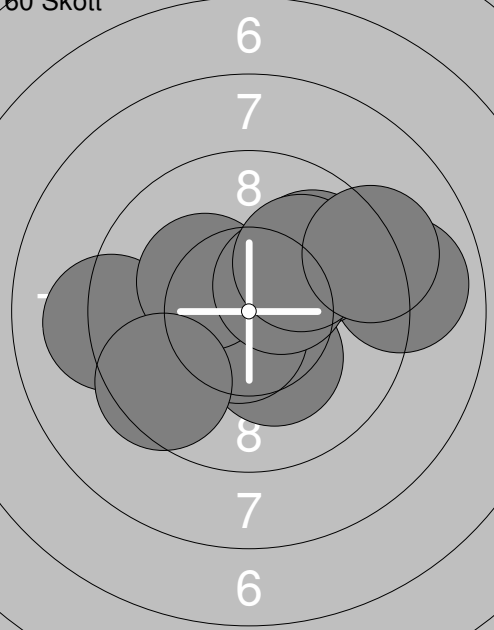
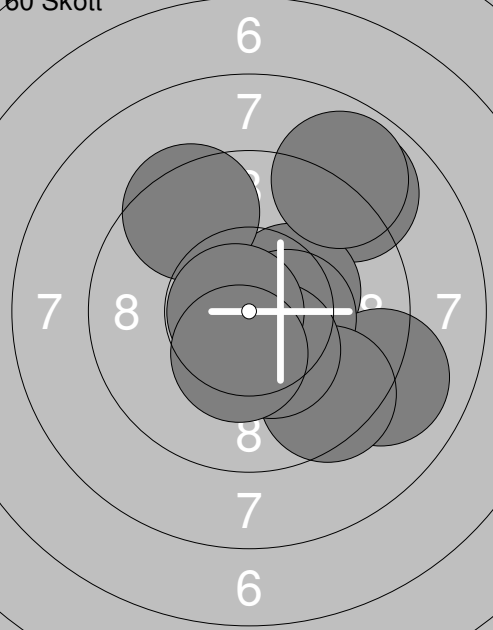

Skjutlag	Tavla	Hanna Augustsson	
1	29		
S	Vännäs		
13.01.2019	Skyttiaden 2019	Umeå skytteallians	
Provs 	1: 10.0 ↘ 2: 10.0 ➡ 3: 10.2x ↗ 4: 10.2x ↓ 5: 10.2x ↓ 6: 10.4x ↓ 7: 10.6x ↗ 8: 10.5x ↘ 9: 10.4x ↗ 10: 10.5x ➡	Provs 	11: 10.7x ↘ 12: 10.3x ➡ 13: 10.4x ↓ 14: 10.5x ↓ 15: 10.5x ➡ 16: 10.1 ↖ 17: 9.8 ↘ 18: 10.5x ↗ 19: 10.4x ➡ 20: 10.7x ↗
	Serie 103.0		Serie 103.9
	Total 0.0		Total 0.0
60 Skott 	1: 10.5x ↗ 2: 10.0 ↓ 3: 10.3x ➡ 4: 10.4x ↘ 5: 10.3x ↓ 6: 10.9x ↓ 7: 10.1 ↓ 8: 10.5x ↗ 9: 10.4x ➡ 10: 10.1 ↓	60 Skott 	11: 10.6x ↓ 12: 10.7x ↘ 13: 10.2x ↘ 14: 9.9 ↓ 15: 10.7x ↓ 16: 10.4x ↓ 17: 10.8x ↘ 18: 10.6x ↗ 19: 10.6x ↓ 20: 10.8x ↗
	Serie 103.5		Serie 105.3
	Total 103.5		Total 208.8
60 Skott 	21: 10.7x ↘ 22: 10.2x ➡ 23: 10.3x ➡ 24: 10.7x ↓ 25: 10.3x ↗ 26: 10.3x ➡ 27: 10.7x ➡ 28: 10.6x ↓ 29: 10.5x ↗ 30: 10.0 ↓	60 Skott 	31: 10.7x ↓ 32: 10.5x ↓ 33: 10.3x ↘ 34: 9.9 ← 35: 10.0 ← 36: 10.6x ↓ 37: 10.2x ↗ 38: 9.8 ↓ 39: 10.5x ↓ 40: 10.0 ↘
	Serie 104.3		Serie 102.5
	Total 313.1		Total 415.6

Skjutlag	Tavla	Dennis Alenius	
1	30		
S	Ramselefors		
13.01.2019	Skyttiaden 2019	Umeå skytteallians	
Prov 	1: 9.6 ↙	Prov 	11: 9.9 ↗
	2: 8.5 ←		12: 9.6 ↘
	3: 10.5x ↘		
	4: 10.2x ↓		
	5: 9.7 ←		
	6: 9.6 ↘		
	7: 10.0 ↘		
	8: 10.4x ↑		
	9: 9.2 ↗		
	10: 9.3 ↗		
	Serie 97.0		Serie 19.5
	Total 0.0		Total 0.0
60 Skott 	1: 9.7 ↗	60 Skott 	11: 10.3x ↘
	2: 9.0 ↑		12: 10.3x ↘
	3: 8.6 →		13: 10.0 ↓
	4: 10.3x ↑		14: 9.7 ↓
	5: 9.6 ↘		15: 9.0 ↗
	6: 10.2x ↓		16: 10.6x ↓
	7: 8.7 ↓		17: 9.9 ←
	8: 9.8 ↓		18: 9.7 ↘
	9: 10.0 ↓		19: 10.4x ↘
	10: 10.2x ↘		20: 10.7x ↑
	Serie 96.1		Serie 100.6
	Total 96.1		Total 196.7
60 Skott 	21: 10.3x ↓	60 Skott 	31: 8.9 ↗
	22: 10.6x ↓		32: 10.3x ↗
	23: 9.2 ←		33: 9.5 ↗
	24: 10.3x ↘		34: 9.0 ↘
	25: 9.5 ↙		35: 8.9 ↗
	26: 8.9 →		36: 10.4x →
	27: 9.9 ↗		37: 9.5 ↘
	28: 10.4x ↗		38: 10.4x ↓
	29: 10.0 ↗		39: 10.8x ↘
	30: 9.2 ↗		40: 10.4x ↓
	Serie 98.3		Serie 98.1
	Total 295.0		Total 393.1

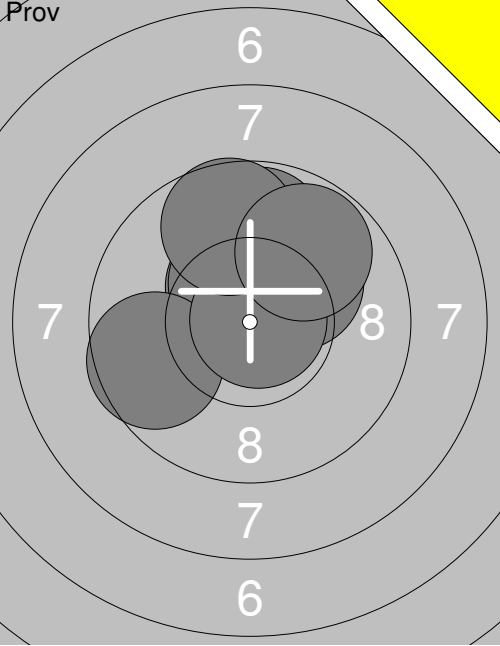
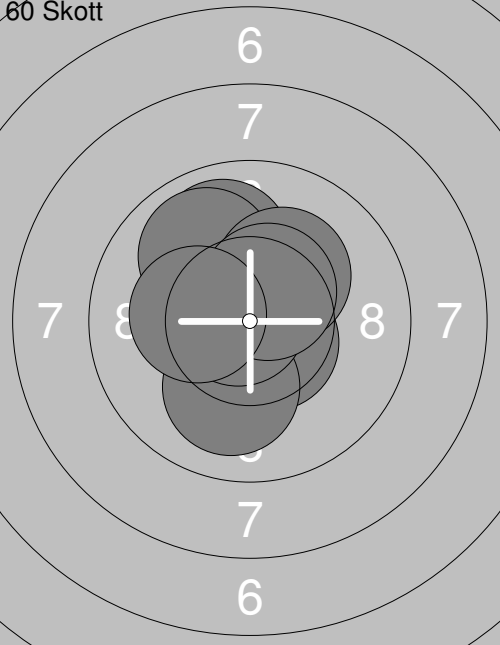
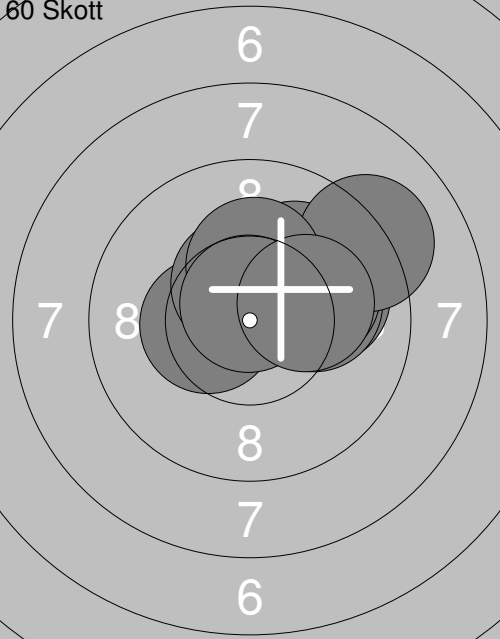
Skjutlag	Tavla	Ylva Lundstedt	
1	31		
S	Ramselefors		
13.01.2019	Skyttiaden 2019	Umeå skytteallians	
Prov		1: 10.4x ↗ 2: 9.8 ↑ 3: 10.2x ↗ 4: 9.9 ↑ 5: 10.4x ↗ 6: 10.4x ↗ 7: 9.6 ← 8: 10.8x → 9: 9.7 ↑ 10: 9.8 ↗	11: 10.2x ↗ 12: 10.5x ↘
		Serie 101.0	Serie 20.7
		Total 0.0	Total 0.0
60 Skott		1: 10.6x ↘ 2: 9.9 ↑ 3: 10.3x ↘ 4: 10.5x ↘ 5: 10.1 ↓ 6: 10.8x ↘ 7: 9.9 ↗ 8: 10.2x ↗ 9: 10.5x ↗ 10: 10.3x ↘	11: 9.5 ↙ 12: 10.7x ↗ 13: 10.2x ↗ 14: 10.2x ↘ 15: 10.3x ↘ 16: 9.1 ↑ 17: 9.7 ↓ 18: 10.4x ↘ 19: 9.6 ↑ 20: 10.0 →
		Serie 103.1	Serie 99.7
		Total 103.1	Total 202.8
60 Skott		21: 10.0 → 22: 10.1 → 23: 10.4x ↘ 24: 10.5x ↗ 25: 10.1 ↗ 26: 10.1 → 27: 9.1 ↗ 28: 10.2x ↗ 29: 10.7x ↗ 30: 10.2x →	31: 9.5 ↗ 32: 10.6x ↗ 33: 10.5x ↘ 34: 10.6x ↘ 35: 10.5x ↗ 36: 10.9x ↘ 37: 10.1 ↑ 38: 9.9 → 39: 10.1 ↑ 40: 10.5x ↘
		Serie 101.4	Serie 103.2
		Total 304.2	Total 407.4

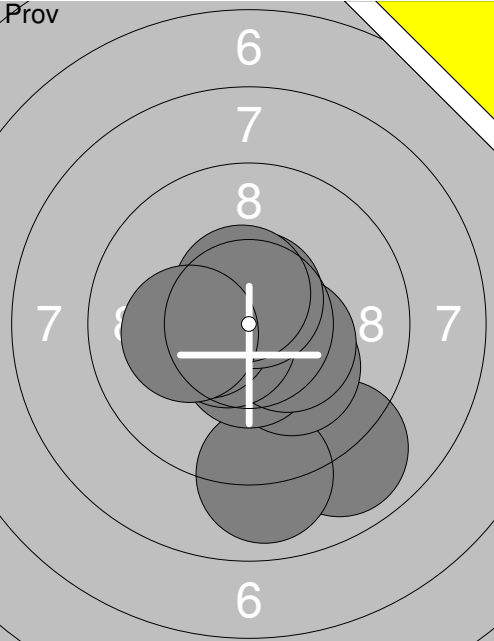
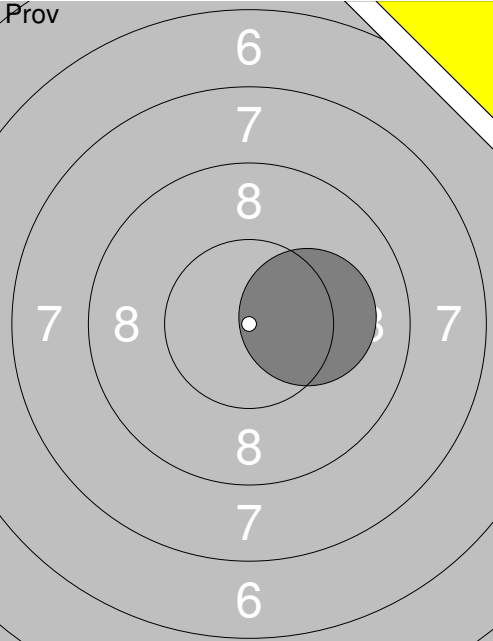
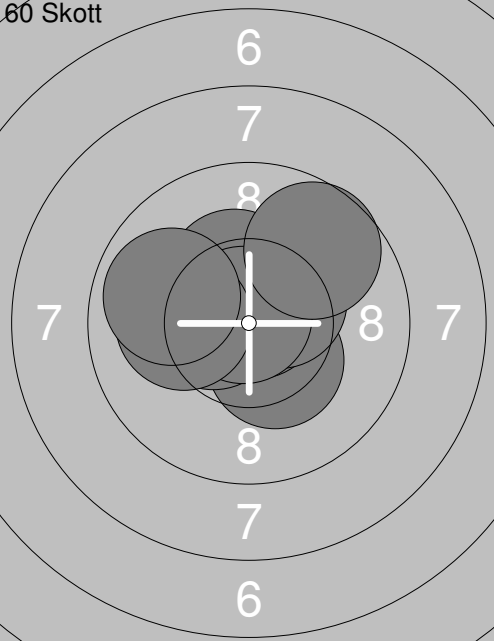
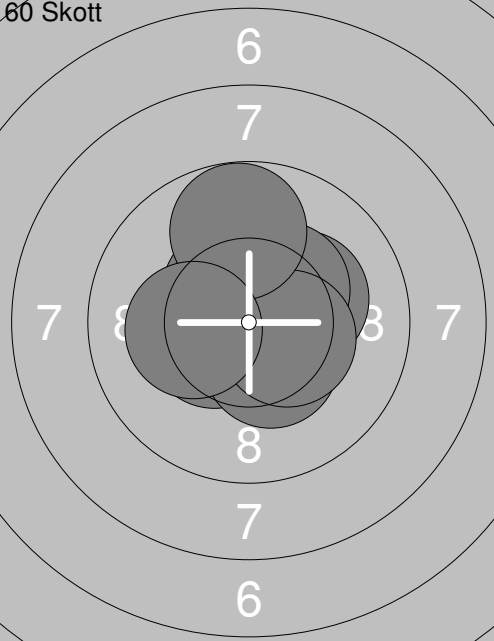
Skjutlag	Tavla	Izabelle Mikaelsson	
1	32		
S	Ramselefors		
13.01.2019	Skyttiaden 2019	Umeå skytteallians	
Prov		1: 8.9 ↘ 2: 9.0 ↓ 3: 10.2x↘ 4: 10.5x↓ 5: 10.4x↘ 6: 10.6x↙ 7: 10.4x← 8: 10.6x↗ 9: 10.5x↗ 10: 10.2x← Serie 101.3 Total 0.0	11: 10.2x➤  Serie 10.2 Total 0.0
60 Skott		1: 10.4x↗ 2: 10.4x↘ 3: 10.5x← 4: 10.8x↗ 5: 10.5x↗ 6: 10.3x↗ 7: 10.8x↘ 8: 10.1← 9: 9.7 ↗ 10: 9.9 ← Serie 103.4 Total 103.4	11: 9.9 ↗ 12: 9.8 ↑ 13: 10.3x↗ 14: 9.9 ↗ 15: 10.8x← 16: 10.7x➤ 17: 10.4x↓ 18: 10.4x↓ 19: 10.0➔ 20: 10.0← Serie 102.2 Total 205.6
60 Skott		21: 10.5x↘ 22: 10.8x↘ 23: 10.5x← 24: 10.5x↗ 25: 10.4x↘ 26: 10.2x➤ 27: 10.4x↗ 28: 10.4x➤ 29: 9.8 ↑ 30: 10.2x← Serie 103.7 Total 309.3	31: 10.3x↓ 32: 9.6 ↗ 33: 9.9 ↓ 34: 10.1➤ 35: 9.8 ↓ 36: 10.6x↘ 37: 10.7x← 38: 10.5x↗ 39: 10.6x↘ 40: 9.6 ➤ Serie 101.7 Total 411.0

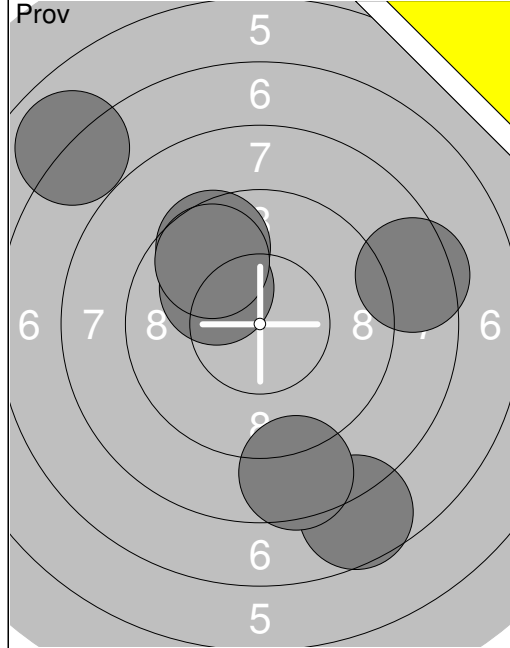

1:	6.9 ↖
2:	9.5 ↖
3:	10.1 ↖
4:	8.4 →
5:	7.6 ↓
6:	8.6 ↓
7:	9.7 ↖
<b>Serie</b>	<b>60.8</b>
<b>Total</b>	<b>0.0</b>

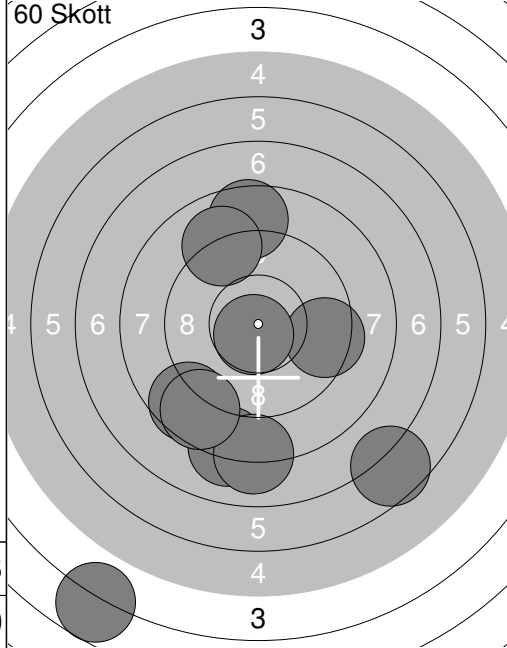

1:	3.7 ↓
2:	6.6 ↓
3:	9.4 →
4:	8.1 ↓
5:	8.6 ↙
6:	8.6 ↑
7:	9.0 ↖
8:	8.0 ↓
9:	10.7x ↘
10:	8.6 ↓
<b>Serie</b>	<b>81.3</b>
<b>Total</b>	<b>81.3</b>

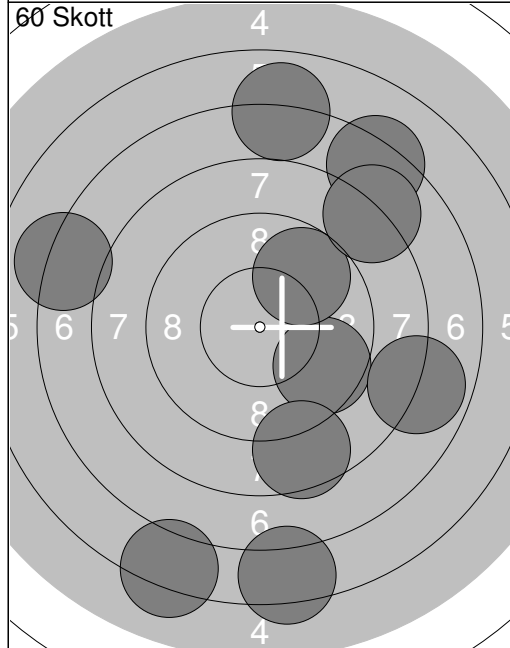

11:	7.1 ←
12:	9.6 →
13:	7.3 ↗
14:	6.4 ↓
15:	8.6 ↓
16:	9.8 ↗
17:	8.0 ↗
18:	6.2 ↓
19:	7.9 →
20:	7.0 ↑
<b>Serie</b>	<b>77.9</b>
<b>Total</b>	<b>159.2</b>

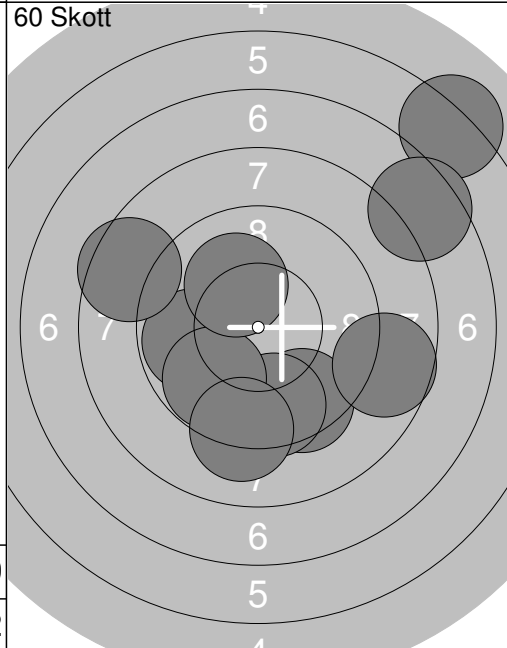

21:	6.2 ↗
22:	9.5 ↓
23:	9.8 ←
24:	8.5 ←
25:	8.7 →
26:	9.6 ↓
27:	9.8 ↙
28:	10.1 ↖
29:	7.5 ↗
30:	9.2 ↓
<b>Serie</b>	<b>88.9</b>
<b>Total</b>	<b>248.1</b>

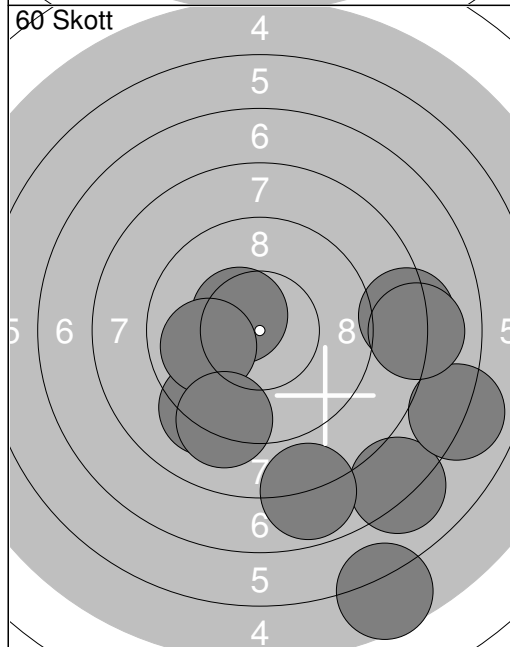

31:	10.5x ↘
32:	9.2 ↓
33:	7.1 ↓
34:	8.2 →
35:	10.0 ←
36:	5.6 ↓
37:	7.0 →
38:	7.8 ↓
39:	9.2 ↓
40:	8.1 →
<b>Serie</b>	<b>82.7</b>
<b>Total</b>	<b>330.8</b>

<p>Prov</p>	<p>60 Skott</p>	
<p>60 Skott</p>	<p>60 Skott</p>	<p>60 Skott</p>
<p>Serie 102.3</p> <p>Total 0.0</p>	<p>Serie 102.8</p> <p>Total 102.8</p>	<p>Serie 100.8</p> <p>Total 203.6</p>
<p>Serie 102.8</p> <p>Total 409.6</p>	<p>Serie 103.2</p> <p>Total 306.8</p>	<p>Serie 102.8</p> <p>Total 409.6</p>

	<p>1: 10.3x ↗</p> <p>2: 8.1 ↙</p> <p>3: 9.2 ↙</p> <p>4: 9.6 ←</p> <p>5: 8.9 →</p> <p>6: 8.0 ↓</p> <p>7: 9.7 →</p> <p>8: 7.4 ↙</p> <p>9: 8.3 ↙</p> <p>10: 9.2 ↗</p>	
Serie 88.7		Serie 10.1
Total 0.0		Total 0.0

	<p>1: 9.6 ↙</p> <p>2: 10.7x ↗</p> <p>3: 10.4x ↘</p> <p>4: 9.6 ↗</p> <p>5: 10.3x ↓</p> <p>6: 7.8 ←</p> <p>7: 9.0 ↓</p> <p>8: 7.8 ↓</p> <p>9: 9.7 ↓</p> <p>10: 8.9 ↗</p>	
Serie 93.8		Serie 88.0
Total 93.8		Total 181.8

	<p>21: 10.3x ↘</p> <p>22: 5.8 →</p> <p>23: 9.4 ↙</p> <p>24: 9.9 ↓</p> <p>25: 8.9 ↗</p> <p>26: 9.3 →</p> <p>27: 10.4x ↘</p> <p>28: 8.8 →</p> <p>29: 7.5 ↑</p> <p>30: 7.0 ←</p>	
Serie 87.3		Serie 89.9
Total 269.1		Total 359.0

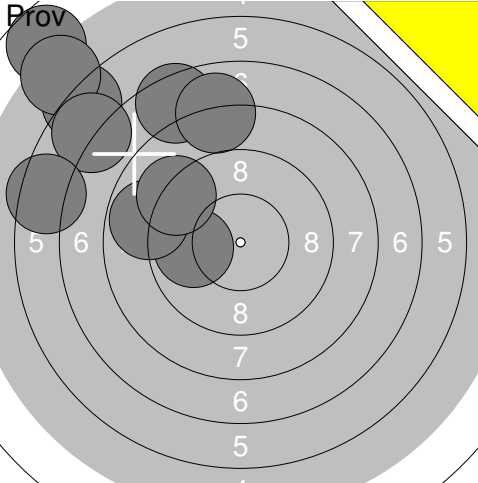
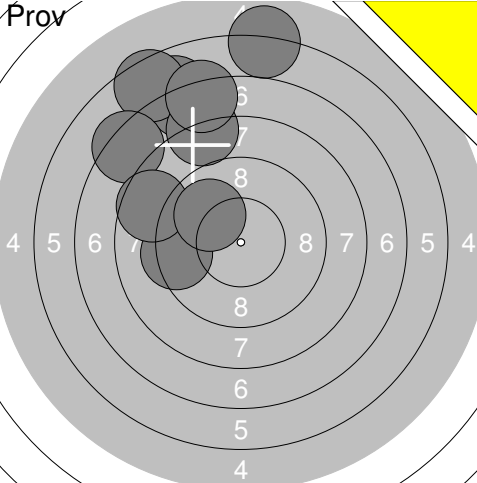
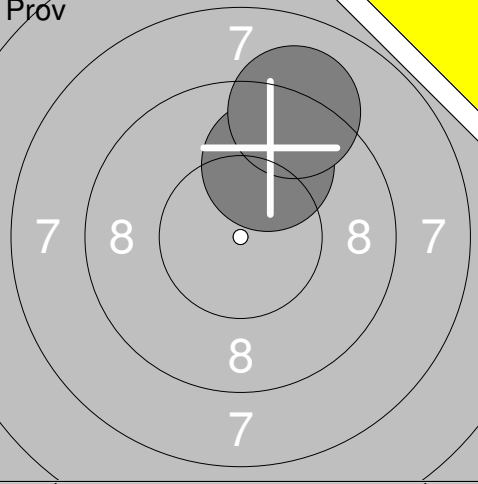
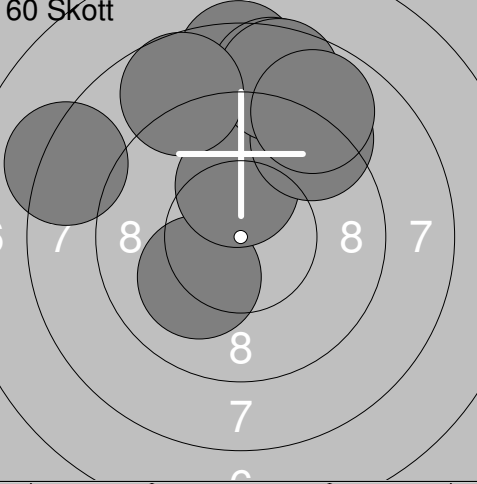
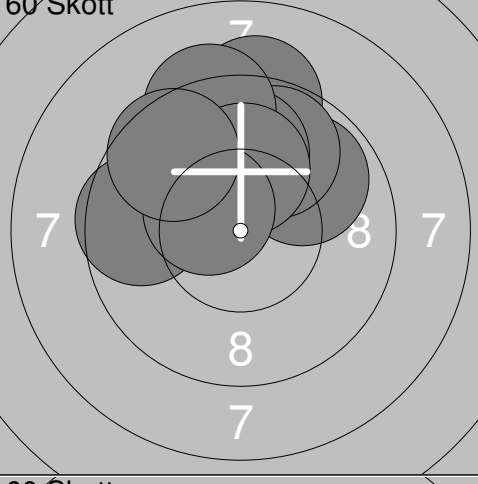
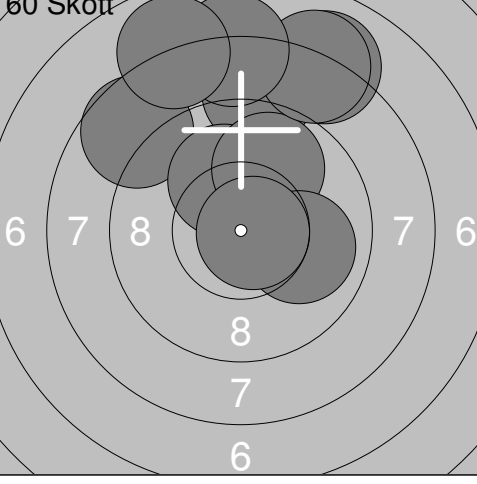
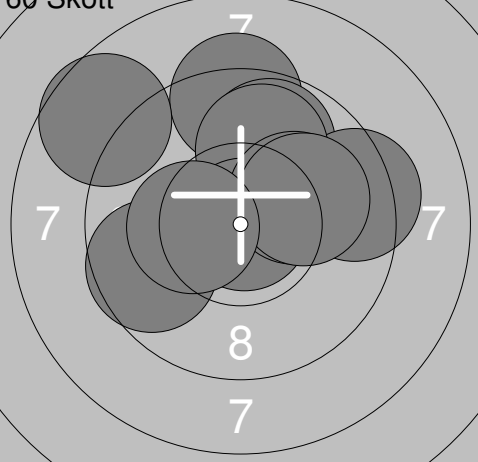
Skjutlag <b>1</b>	Tavla <b>40</b>	<b>Jan-Olov Jonsson</b>			
<b>S</b>		<b>Umeå</b>			
<b>13.01.2019</b>		<b>Skyttiaden 2019</b>		<b>Umeå skytteallians</b>	
<b>Prov</b>		1: 9.9 ← 2: 6.2 ↗ 3: 4.7 ↗ 4: 7.5 ↗ 5: 8.0 ↗ 6: 5.4 ↗ 7: 6.8 ↗ 8: 8.8 ↖ 9: 9.2 ↗ 10: 6.4 ↖	<b>Prov</b>		11: 6.9 ↗ 12: 7.2 ↗ 13: 6.5 ↗ 14: 8.0 ↗ 15: 6.0 ↑ 16: 7.3 ↖ 17: 7.2 ↑ 18: 9.3 ← 19: 8.6 ↖ 20: 9.9 ↖
		Serie 72.9 Total 0.0			Serie 76.9 Total 0.0
<b>Prov</b>		21: 9.9 ↑ 22: 9.1 ↑	<b>60 Skott</b>		1: 9.4 ↑ 2: 8.4 ↑ 3: 10.1 ↙ 4: 8.6 ↑ 5: 10.2x ↑ 6: 9.2 ↗ 7: 8.6 ↑ 8: 8.9 ↑ 9: 8.2 ↖ 10: 8.7 ↖
		Serie 19.0 Total 0.0			Serie 90.3 Total 90.3
<b>60 Skott</b>		11: 9.2 ↑ 12: 9.9 ↗ 13: 9.6 ← 14: 10.0 ↑ 15: 9.8 ↑ 16: 9.9 ↑ 17: 9.3 ↑ 18: 10.1 ↑ 19: 10.4x ↗ 20: 9.6 ↖	<b>60 Skott</b>		21: 8.7 ↑ 22: 8.0 ↗ 23: 8.7 ↖ 24: 10.1 ↗ 25: 9.9 ↗ 26: 10.0 → 27: 10.8x → 28: 8.1 ↑ 29: 8.1 ↑ 30: 7.9 ↖
		Serie 97.8 Total 188.1			Serie 90.3 Total 278.4
<b>60 Skott</b>		31: 9.3 ↑ 32: 9.8 ↑ 33: 8.6 ↖ 34: 9.4 → 35: 9.9 ↑ 36: 9.6 ↖ 37: 10.9x → 38: 10.1 ↗ 39: 10.0 → 40: 10.3x ←			
		Serie 97.9 Total 376.3			

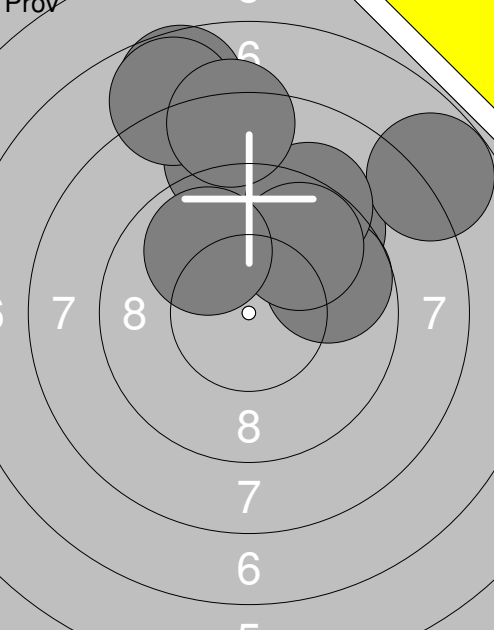
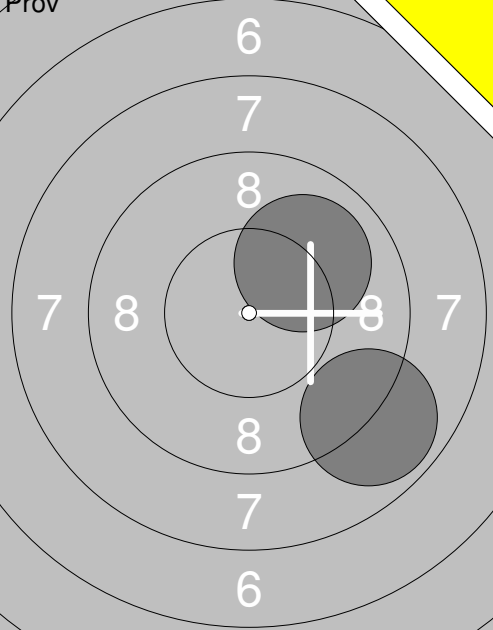
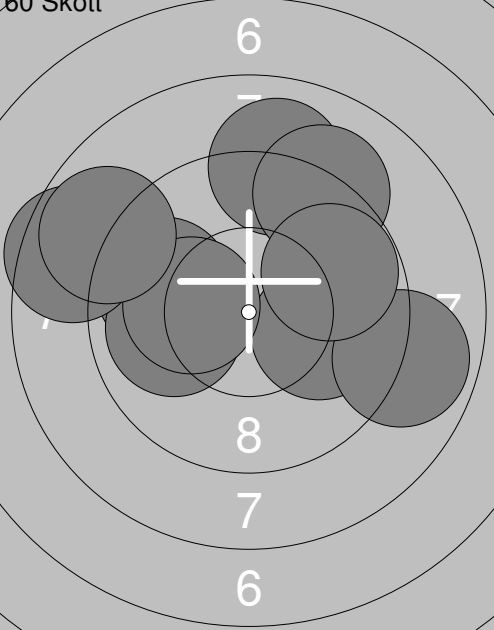
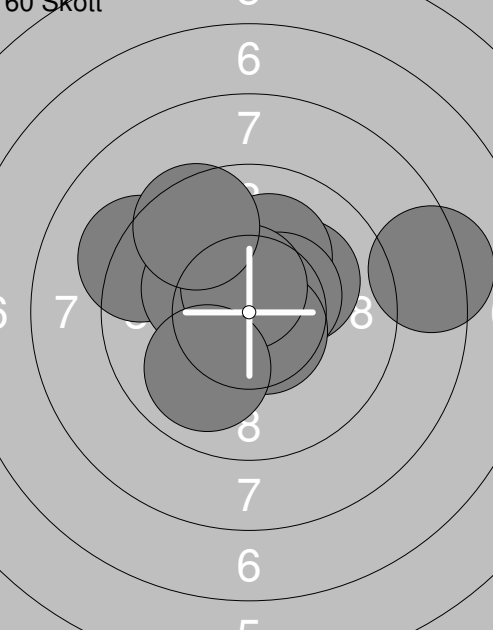
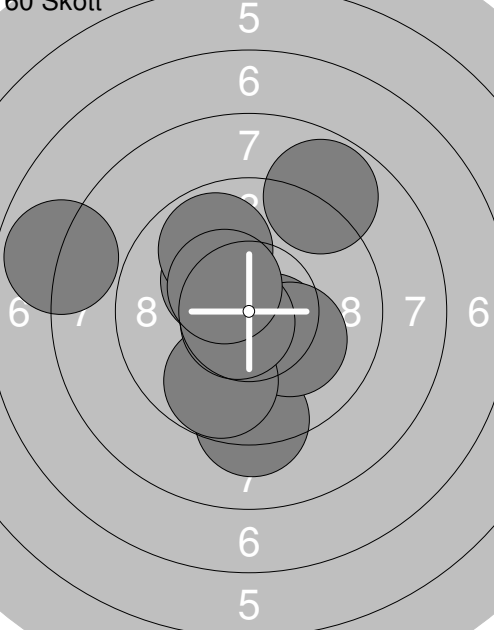
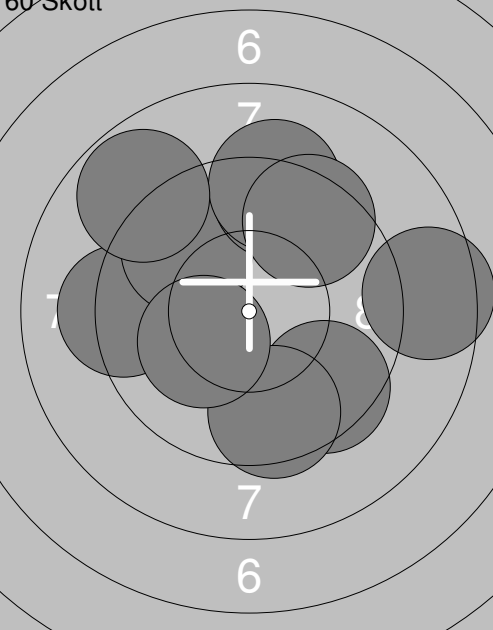

 <p style="font-size: small;">Prov</p>	<p>1: 7.7 ↗</p> <p>2: 9.4 ↗</p> <p>3: 7.8 ↗</p> <p>4: 8.8 ↑</p> <p>5: 7.8 ↖</p> <p>6: 9.7 →</p> <p>7: 9.2 ↗</p> <p>8: 9.8 ↗</p> <p>9: 8.3 ↑</p> <p>10: 9.9 ↖</p> <p>Serie 88.4</p> <p>Total 0.0</p>	 <p style="font-size: small;">Prov</p>	<p>11: 8.9 ↘</p> <p>12: 10.0 ↗</p> <p>Serie 18.9</p> <p>Total 0.0</p>
<p>60 Skott</p> 	<p>1: 10.0 →</p> <p>2: 8.9 →</p> <p>3: 9.8 ←</p> <p>4: 10.0 ←</p> <p>5: 8.5 ←</p> <p>6: 10.2x ←</p> <p>7: 9.0 ↑</p> <p>8: 8.8 ←</p> <p>9: 9.1 ↗</p> <p>10: 9.8 ↗</p> <p>Serie 94.1</p> <p>Total 94.1</p>	<p>60 Skott</p> 	<p>11: 10.1 ↗</p> <p>12: 9.2 ↖</p> <p>13: 10.1 ↑</p> <p>14: 10.2x ↖</p> <p>15: 10.5x ↗</p> <p>16: 8.3 →</p> <p>17: 10.6x ↘</p> <p>18: 10.6x ↗</p> <p>19: 9.5 ↖</p> <p>20: 10.0 ↘</p> <p>Serie 99.1</p> <p>Total 193.2</p>
<p>60 Skott</p> 	<p>21: 9.3 ↓</p> <p>22: 10.3x ↖</p> <p>23: 10.5x ↘</p> <p>24: 7.9 ←</p> <p>25: 9.9 ↖</p> <p>26: 10.2x ↘</p> <p>27: 9.8 ↓</p> <p>28: 10.7x ↖</p> <p>29: 8.8 ↗</p> <p>30: 10.4x ↖</p> <p>Serie 97.8</p> <p>Total 291.0</p>	<p>60 Skott</p> 	<p>31: 9.2 ←</p> <p>32: 9.5 ↘</p> <p>33: 9.8 ↗</p> <p>34: 9.5 ↓</p> <p>35: 9.3 ↑</p> <p>36: 8.5 →</p> <p>37: 9.2 ↑</p> <p>38: 10.2x ↖</p> <p>39: 8.8 ↖</p> <p>40: 9.5 ↗</p> <p>Serie 93.5</p> <p>Total 384.5</p>

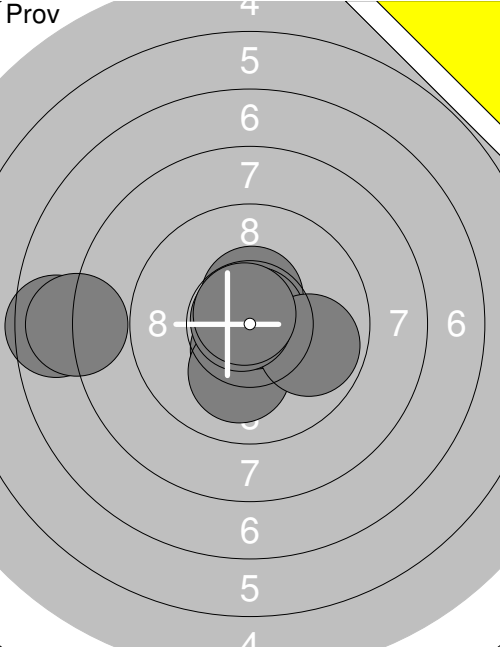
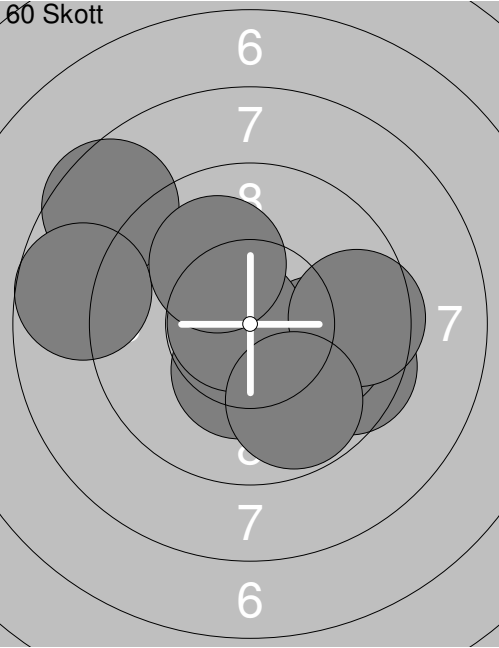
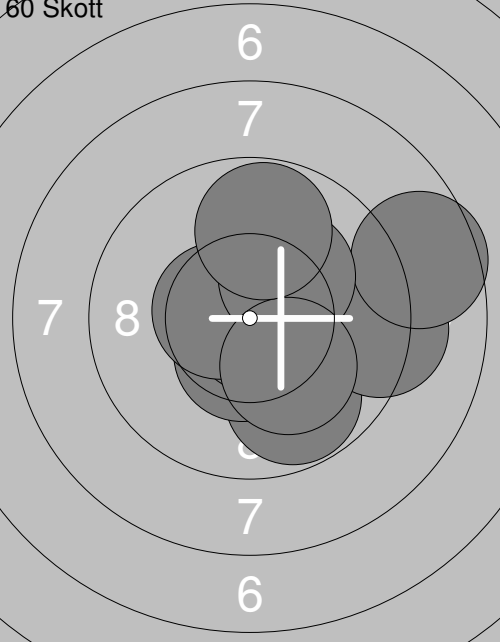
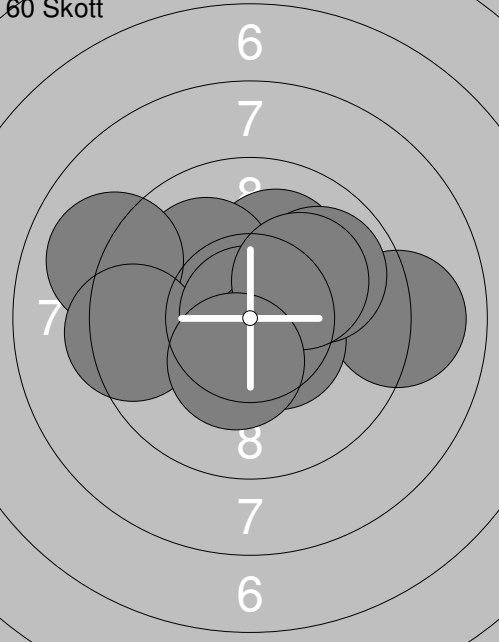
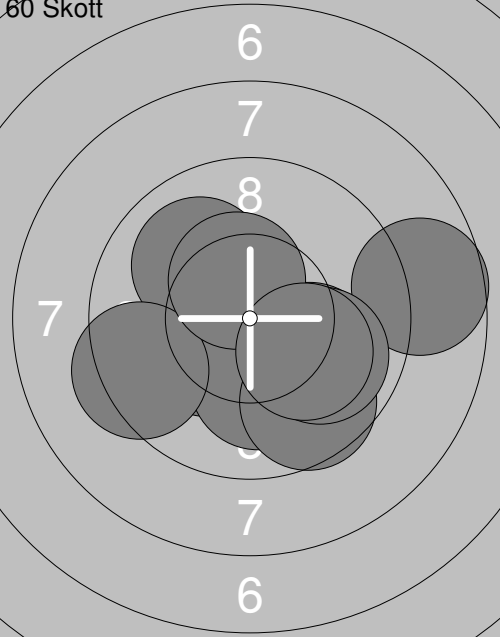
Skjutlag	Tavla	Helena Dreyer Perkiömäki	
2	3		
S	Umeå		
13.01.2019	Skyttiaden 2019	Umeå skytteallians	
Prov		60 Skott	
	1: 7.6 ← 2: 7.9 ← 3: 10.5x ↓ 4: 10.5x ↑ 5: 10.1 ↓ 6: 10.8x ↑ 7: 9.9 → 8: 10.8x ← 9: 10.8x ↓	1: 8.6 ↗ 2: 8.7 ← 3: 9.6 → 4: 10.3x ↓ 5: 10.4x ↓ 6: 10.0 → 7: 10.8x ← 8: 9.6 → 9: 10.1 ↗ 10: 9.8 ↓	
	Serie 88.9	Serie 97.9	
	Total 0.0	Total 97.9	
60 Skott		60 Skott	
	11: 10.6x → 12: 9.8 ↓ 13: 10.5x ↓ 14: 9.2 → 15: 10.8x ↓ 16: 8.6 → 17: 10.5x ← 18: 10.2x ↑ 19: 10.2x ↓ 20: 9.8 ↑	21: 10.1 ↑ 22: 10.1 ↗ 23: 9.0 ← 24: 9.0 → 25: 9.4 ← 26: 10.9x ↓ 27: 10.5x ↓ 28: 9.9 ↗ 29: 10.1 ↗ 30: 10.4x ↓	
	Serie 100.2	Serie 99.4	
	Total 198.1	Total 297.5	
60 Skott			
	31: 10.3x ← 32: 10.0 ↗ 33: 10.1 ↓ 34: 9.4 ← 35: 9.6 ↓ 36: 8.7 → 37: 10.1 → 38: 10.4x ↑ 39: 9.9 → 40: 10.1 ↓		
	Serie 98.6		
	Total 396.1		

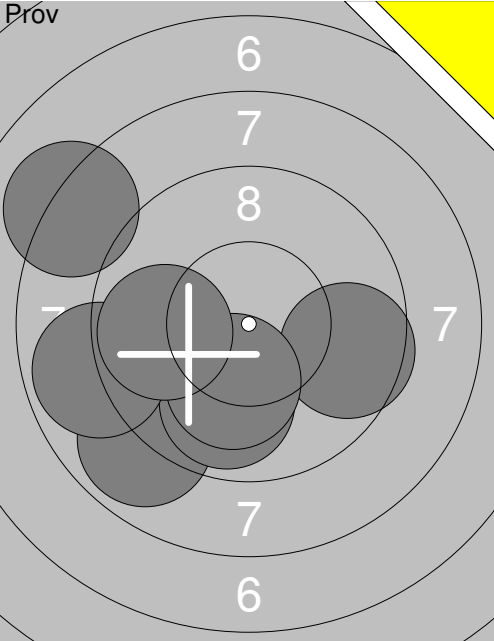
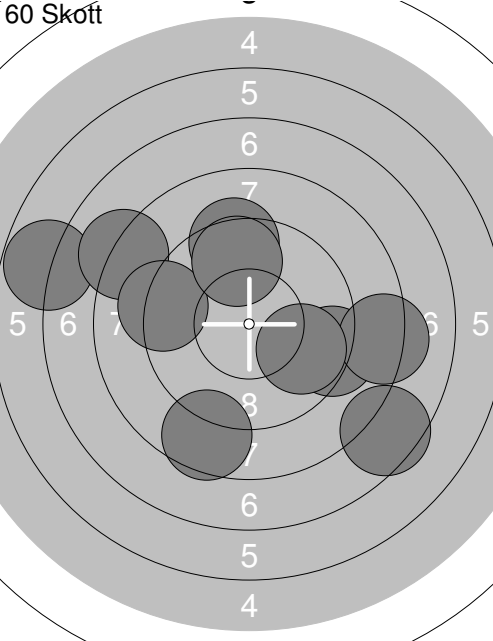
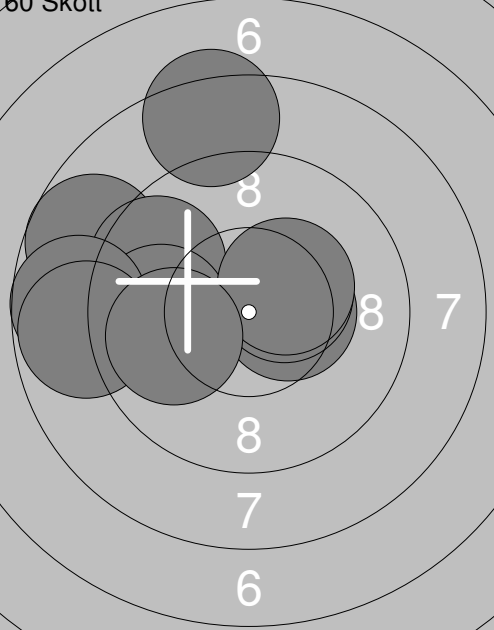
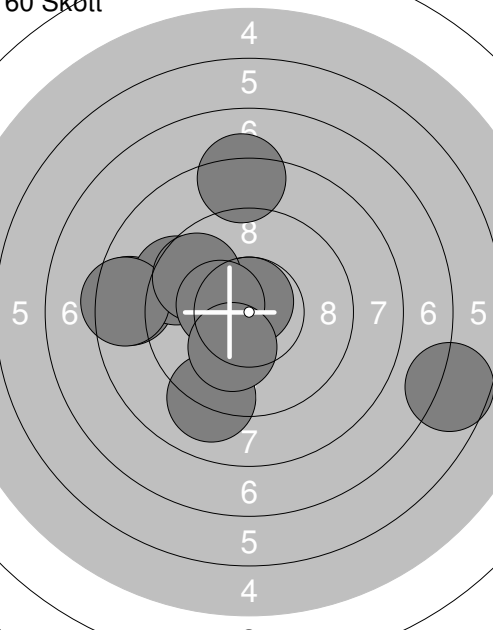
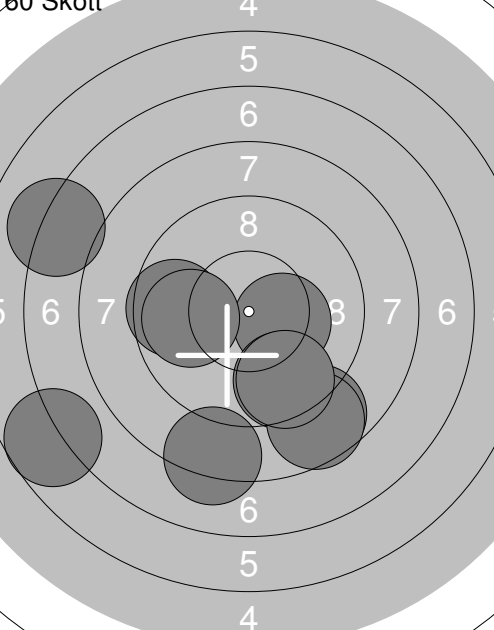
Skjutlag <b>2</b>	Tavla <b>4</b>	<b>Ebba Lundstedt</b>	
S		Ramselefors	
13.01.2019		Skyttiaden 2019	Umeå skytteallians
Pröv		1: 8.1 ↖ 2: 9.6 → 3: 8.9 ↙ 4: 9.9 ↓ 5: 8.9 ← 6: 10.2x↓ 7: 9.8 ←	60 Skott  1: 7.5 ↘ 2: 9.2 → 3: 8.3 → 4: 6.8 ← 5: 8.1 ↖ 6: 9.3 ↑ 7: 9.2 ← 8: 9.7 ↑ 9: 8.6 ↓ 10: 9.8 →
		Serie 65.4	Serie 86.5
		Total 0.0	Total 86.5
60 Skott		11: 10.4x→ 12: 10.4x↗ 13: 8.4 ↑ 14: 8.7 ← 15: 9.6 ← 16: 9.8 ← 17: 10.4x↗ 18: 8.7 ← 19: 8.8 ← 20: 9.9 ←	60 Skott  21: 8.5 ← 22: 8.3 ↑ 23: 9.4 ← 24: 9.1 ↓ 25: 8.4 ← 26: 10.7x↑ 27: 9.7 ↖ 28: 6.7 → 29: 10.3x↖ 30: 10.2x↓
		Serie 95.1	Serie 91.3
		Total 181.6	Total 272.9
60 Skott		31: 7.1 ← 32: 6.7 ← 33: 10.3x→ 34: 9.6 ↓ 35: 9.6 ← 36: 8.7 ↓ 37: 9.9 ← 38: 8.6 ↓ 39: 9.6 ↓ 40: 8.2 ↓	
		Serie 88.3	
		Total 361.2	

Skjutlag <b>2</b>	Tavla <b>5</b>	<b>Hanna Augustsson</b>	
S		Vännäs	
13.01.2019		Skyttiaden 2019	Umeå skytteallians
Prov		1: 7.7 ↗ 2: 9.3 ← 3: 9.7 → 4: 10.0 ← 5: 7.8 → 7: 10.5x → 8: 9.4 ↑ 9: 10.0 ↑ 10: 7.9 →	11: 9.0 ↙ 12: 10.3x ← 13: 9.4 ↗ 14: 9.0 → 15: 6.7 ← 16: 8.1 ← 17: 9.5 → 18: 7.6 ↘ 19: 8.9 ← 20: 9.6 ↑
		Serie 82.3	Serie 88.1
		Total 0.0	Total 0.0
Prov		21: 7.0 → 22: 9.3 ←	1: 9.3 → 2: 8.9 ↘ 3: 9.2 ↑ 4: 10.0 ↗ 5: 9.7 → 6: 4.6 ← 7: 10.1 → 8: 8.3 ↘ 9: 9.4 ↙ 10: 8.0 →
		Serie 16.3	Serie 87.5
		Total 0.0	Total 87.5
60 Skott		11: 8.4 ↙ 12: 9.7 ↙ 13: 9.0 ← 14: 9.0 ← 15: 8.0 ↘ 16: 8.7 ↘ 17: 9.3 → 18: 10.1 ↙ 19: 9.5 ↘ 20: 9.0 →	21: 9.1 ↙ 22: 10.1 ↘ 23: 9.9 ↘ 24: 8.9 ← 25: 9.3 ↗ 26: 9.7 ↘ 27: 9.9 ↗ 28: 9.8 ↗ 29: 9.6 ↘ 30: 10.1 ↘
		Serie 90.7	Serie 96.4
		Total 178.2	Total 274.6
60 Skott		31: 10.4x ↑ 32: 10.7x → 33: 9.6 ↗ 34: 9.4 → 35: 7.0 ← 36: 9.9 ↘ 37: 8.7 → 38: 10.1 ↗ 39: 9.4 ↘ 40: 9.3 ←	
		Serie 94.5	
		Total 369.1	

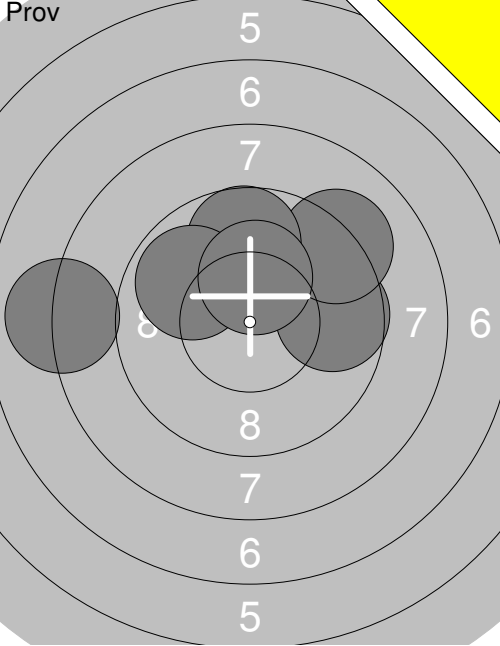
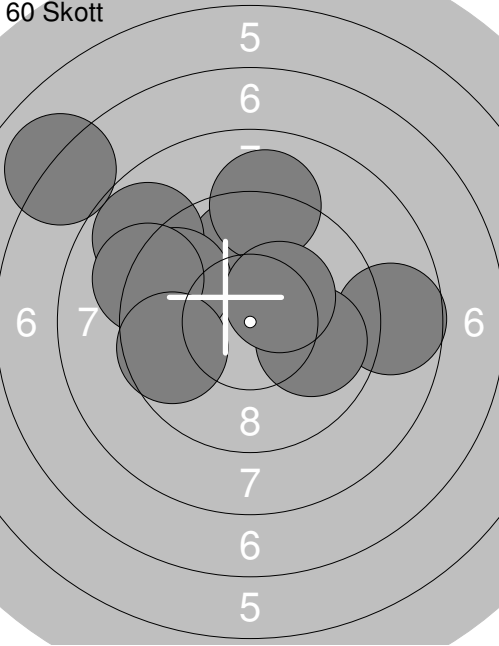
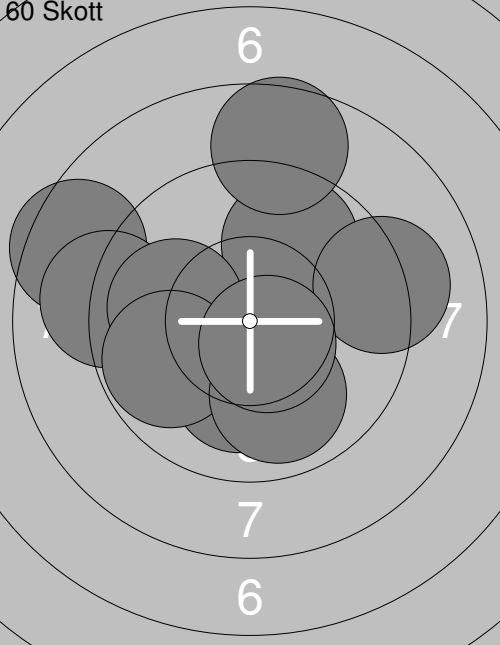
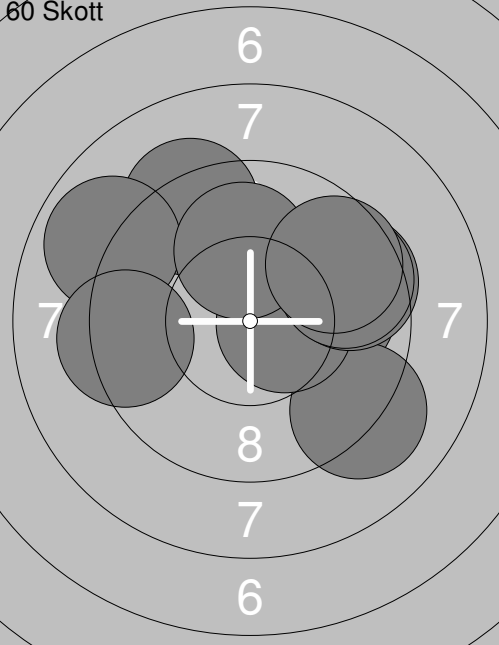
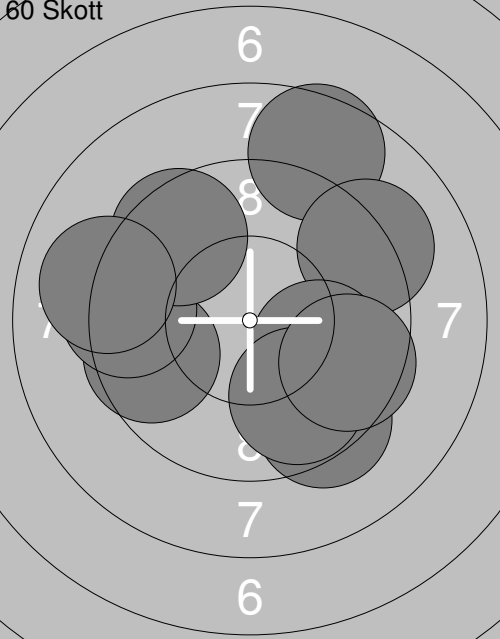
Skjutlag	Tavla	Beatrice Andersson	
S		Ramselefors	
13.01.2019	Skyttiaden 2019	Umeå skytteallians	
Prov		1: 9.7 → 2: 9.2 ↗ 3: 8.0 ← 4: 9.7 ↑ 5: 9.9 ↖ 6: 10.3x↑ Serie 56.8 Total 0.0	60 Skott  1: 8.7 → 2: 9.8 ↑ 3: 8.8 ↖ 4: 9.6 ↖ 5: 9.2 ↖ 6: 7.0 ↖ 7: 9.9 → 8: 9.1 ↑ 9: 10.3x↗ 10: 9.6 ← Serie 92.0 Total 92.0
60 Skott		11: 10.1 ↓ 12: 9.8 ↗ 13: 8.5 ← 14: 8.6 ↑ 15: 9.2 → 16: 9.1 ← 17: 10.0 ← 18: 9.8 ← 19: 9.9 ↓ 20: 10.6x↓ Serie 95.6 Total 187.6	60 Skott  21: 9.9 → 22: 9.1 ↓ 23: 10.5x→ 24: 9.3 ↗ 25: 8.9 ↖ 26: 9.6 → 27: 9.3 ← 28: 10.0 ↑ 29: 9.6 → 30: 9.6 ↗ Serie 95.8 Total 283.4
60 Skott		31: 9.6 ← 32: 9.4 ← 33: 8.6 ↑ 34: 9.2 ↗ 35: 9.5 ↗ 36: 9.0 ← 37: 9.3 ↓ 38: 10.0 → 39: 9.8 ↓ 40: 9.6 → Serie 94.0 Total 377.4	

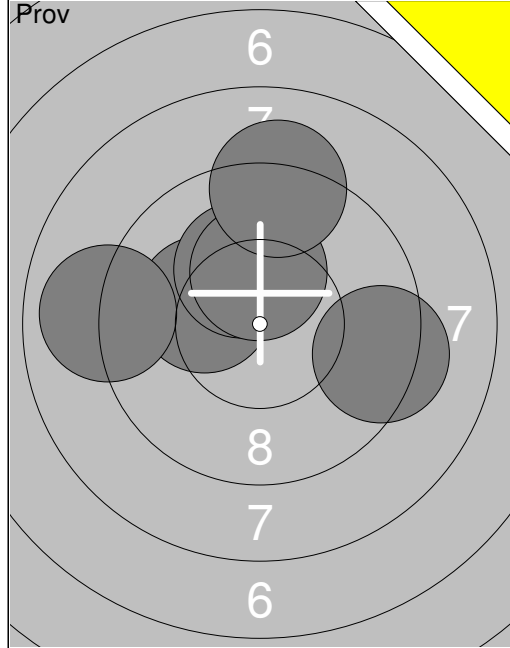

1:	10.2x ↖
2:	10.2x ↗
3:	10.3x ↗
4:	9.0 ←
5:	9.2 ↑
6:	9.3 →
<b>Serie 58.2</b>	
<b>Total 0.0</b>	

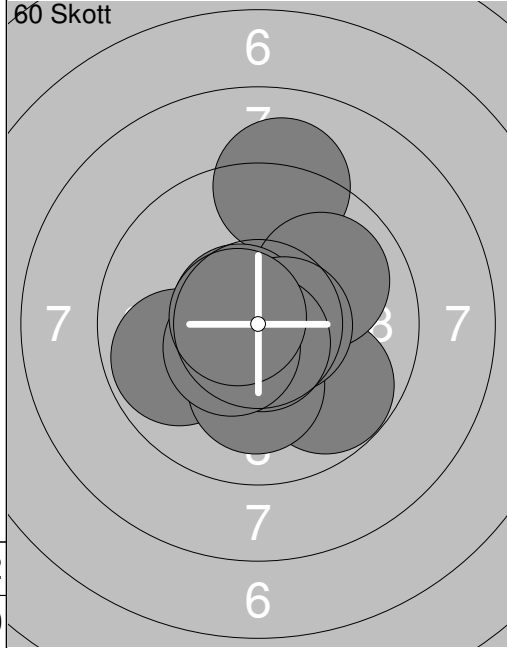

1:	9.8 ←
2:	9.1 ↑
3:	9.8 ↘
4:	10.0 ↗
5:	10.7x ↖
6:	10.1 ↓
7:	10.6x →
8:	10.7x ↓
9:	10.5x ↖
10:	10.7x ↖
<b>Serie 102.0</b>	
<b>Total 102.0</b>	

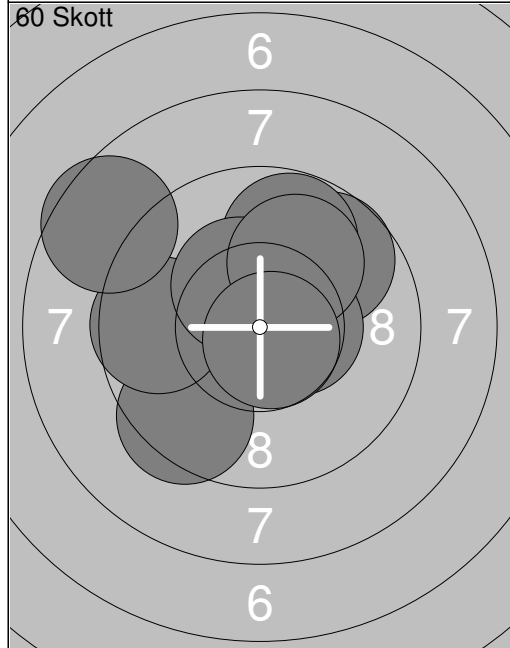

11:	9.7 ↗
12:	10.7x →
13:	9.4 ↘
14:	10.5x →
15:	9.8 ↑
16:	9.6 ←
17:	8.6 ↖
18:	10.3x ↗
19:	10.0 ↗
20:	10.7x ↓
<b>Serie 99.3</b>	
<b>Total 201.3</b>	

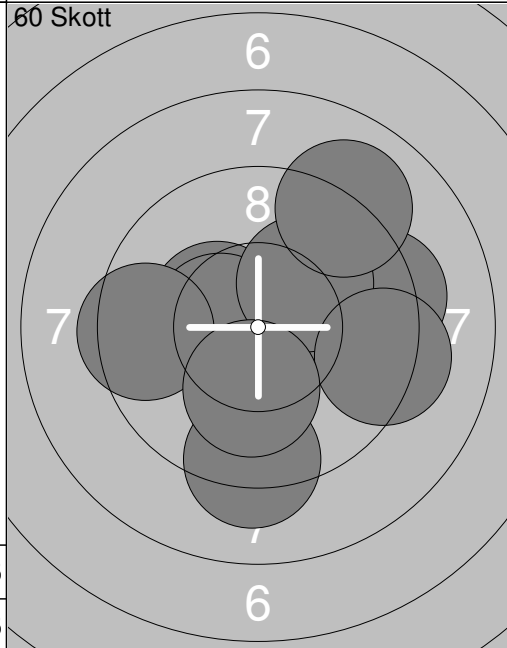

21:	10.2x →
22:	9.3 →
23:	10.4x ↖
24:	9.2 ↓
25:	10.5x ↖
26:	10.1 ↗
27:	9.3 →
28:	9.5 ←
29:	10.1 ↓
30:	9.0 ↗
<b>Serie 97.6</b>	
<b>Total 298.9</b>	

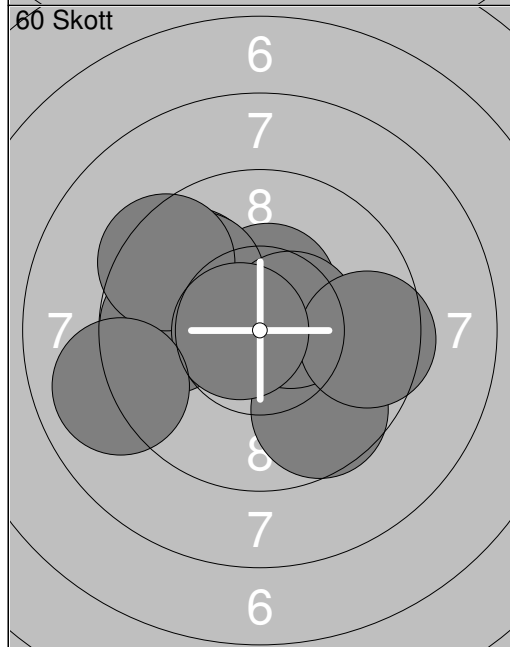

31:	9.8 ↖
32:	10.4x ↗
33:	9.9 ↖
34:	9.7 ↘
35:	10.5x →
36:	9.8 ←
37:	9.4 ↖
38:	9.5 →
39:	10.7x ↖
40:	9.0 ←
<b>Serie 98.7</b>	
<b>Total 397.6</b>	

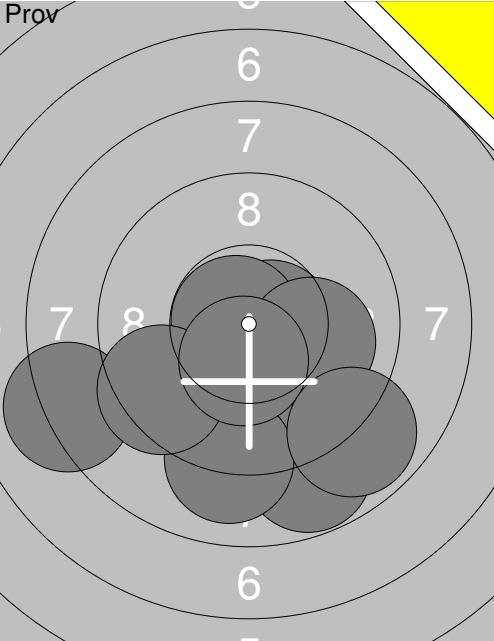
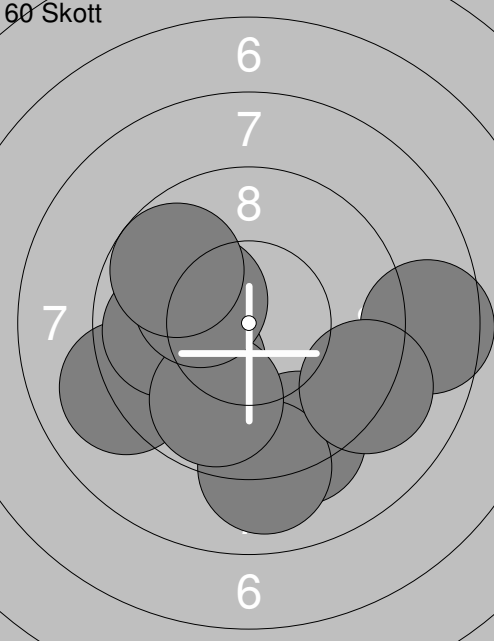
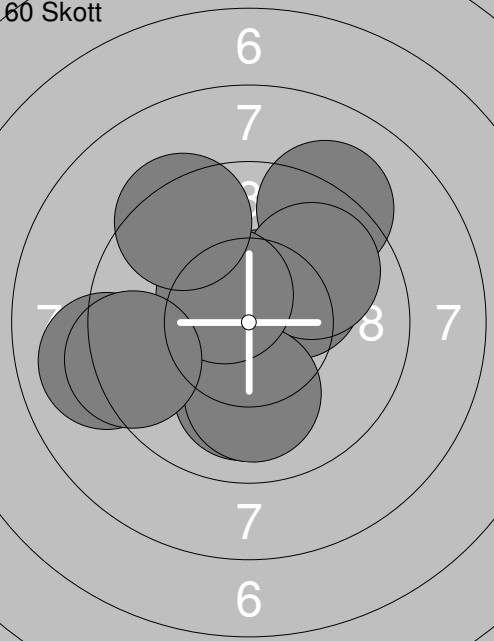
Skjutlag	Tavla	Hanna Johansson	
2	9		
S	Vännäs		
13.01.2019	Skyttiaden 2019	Umeå skytteallians	
Prov		1: 10.7x➤ 2: 9.1 ↓ 3: 8.8 ↓ 4: 9.1 ↓ 5: 10.8x↔ 6: 8.2 ← 7: 9.4 ↙ 8: 10.1 ➤ 9: 10.4x↓ 10: 8.9 ↘ Serie 95.5 Total 0.0	11: 9.0 ↙ 12: 9.0 ↙ 13: 10.2x↓ 14: 10.0 ↘ 15: 10.4x↘ Serie 48.6 Total 0.0
60 Skott		1: 9.3 ↓ 2: 8.6 ➔ 3: 9.0 ↓ 4: 10.1 ↙ 5: 9.1 ← 6: 9.9 ← 7: 9.8 ↓ 8: 9.2 ➤ 9: 10.2x↔ 10: 9.8 ↙ Serie 95.0 Total 95.0	11: 10.0↔ 12: 9.2 ← 13: 10.2x↓ 14: 10.3x↔ 15: 9.6 ↙ 16: 9.7 ← 17: 10.1➔ 18: 9.9 ← 19: 8.9 ➔ 20: 9.9 ↓ Serie 97.8 Total 192.8
60 Skott		21: 10.6x↗ 22: 10.2x↗ 23: 9.2 ↗ 24: 10.0 ↓ 25: 9.9 ↗ 26: 10.0 ↓ 27: 9.0 ← 28: 10.5x↔ 29: 9.4 ↗ 30: 9.4 ← Serie 98.2 Total 291.0	31: 8.5 ➤ 32: 9.6 ← 33: 9.9 ← 34: 10.1 ➤ 35: 9.4 ↓ 36: 8.7 ↓ 37: 10.4x↓ 38: 9.6 ↗ 39: 10.3x↔ 40: 8.7 ↓ Serie 95.2 Total 386.2

Skjuttlag	Tavla	Fluk Jonsson	
S		Ramselefors	
13.01.2019	Skyttiaden 2019	Umeå skytteallians	
Prov		1: 10.0 ↑ 2: 9.1 ➔ 3: 8.6 ← 4: 9.0 ➔ 5: 6.8 ↙ 6: 7.0 ← 7: 8.6 ↗ 8: 7.7 ← 9: 10.2x↓ 10: 8.0 ➔ Serie 85.0 Total 0.0	11: 8.8 ➔ 12: 8.8 ↑ 13: 7.0 ➔ 14: 9.9 ↗ 15: 8.8 ↘ 16: 7.3 ➔ 17: 8.0 ➔ Serie 58.6 Total 0.0
60 Skott		1: 10.5x↘ 2: 8.7 ↑ 3: 8.9 ➔ 4: 8.8 ↘ 5: 9.6 ➔ 6: 7.7 ➔ 7: 7.2 ➔ 8: 10.8x↘ 9: 8.0 ↙ 10: 8.0 ← Serie 88.2 Total 88.2	11: 8.8 ➔ 12: 8.5 ↙ 13: 8.5 ← 14: 8.2 ← 15: 7.3 ↘ 16: 9.2 ↘ 17: 9.0 ↘ 18: 10.0 ↗ 19: 8.9 ➔ 20: 9.4 ➔ Serie 87.8 Total 176.0
60 Skott		21: 7.2 ➔ 22: 10.2x↗ 23: 7.1 ➔ 24: 7.8 ➔ 25: 9.9 ↗ 26: 9.3 ➔ 27: 7.4 ➔ 28: 10.4x↘ 29: 8.7 ↙ 30: 8.6 ↓ Serie 86.6 Total 262.6	31: 8.4 ➔ 32: 9.3 ↘ 33: 10.6x↓ 34: 8.9 ↘ 35: 7.2 ➔ 36: 9.0 ← 37: 9.8 ↙ 38: 8.8 ↙ 39: 8.1 ↗ 40: 10.6x↑ Serie 90.7 Total 353.3



<p>Prov</p>	<p>1: 10.7x➤</p> <p>2: 9.3 ↓</p> <p>3: 10.1 ↖</p> <p>4: 8.9 ←</p> <p>5: 9.6 ←</p> <p>6: 10.2x↑</p> <p>7: 8.6 ←</p> <p>8: 9.7 ↓</p> <p>9: 9.3 ↓</p> <p>10: 8.4 ↑</p> <p>Serie 94.8</p> <p>Total 0.0</p>	<p>Prov</p>	<p>11: 10.2x↘</p> <p>12: 10.0 ↗</p> <p>13: 10.6x↘</p> <p>Serie 30.8</p> <p>Total 0.0</p>
-------------	--	-------------	--

<p>60 Skott</p>	<p>1: 10.3x↘</p> <p>2: 10.7x↘</p> <p>3: 10.5x↘</p> <p>4: 9.4 →</p> <p>5: 10.2x↑</p> <p>6: 8.6 →</p> <p>7: 9.1 ↑</p> <p>8: 9.2 ↓</p> <p>9: 10.4x↘</p> <p>10: 10.6x↘</p> <p>Serie 99.0</p> <p>Total 99.0</p>	<p>60 Skott</p>	<p>11: 9.8 ↖</p> <p>12: 9.6 ↓</p> <p>13: 9.7 ↑</p> <p>14: 10.3x↘</p> <p>15: 9.5 ←</p> <p>16: 7.0 →</p> <p>17: 10.3x↓</p> <p>18: 10.8x↘</p> <p>19: 8.7 ➤</p> <p>20: 10.3x↘</p> <p>Serie 96.0</p> <p>Total 195.0</p>
-----------------	--	-----------------	--

<p>60 Skott</p>	<p>21: 9.0 ↓</p> <p>22: 8.7 ➤</p> <p>23: 8.9 →</p> <p>24: 10.1←</p> <p>25: 9.6 ←</p> <p>26: 8.4 →</p> <p>27: 8.6 →</p> <p>28: 8.9 ↘</p> <p>29: 9.2 ←</p> <p>30: 10.5x↘</p> <p>Serie 91.9</p> <p>Total 286.9</p>	<p>60 Skott</p>	<p>31: 10.7x↑</p> <p>32: 8.9 →</p> <p>33: 10.8x↘</p> <p>34: 9.3 ↗</p> <p>35: 9.9 ↓</p> <p>36: 10.1➤</p> <p>37: 6.3 ←</p> <p>38: 9.0 ←</p> <p>39: 9.6 ➤</p> <p>40: 9.6 ↗</p> <p>Serie 94.2</p> <p>Total 381.1</p>
-----------------	---	-----------------	--

<p>Prov</p> <p style="text-align: right;">Serie 20.8 Total 0.0</p>	<p>60 Skott</p> <p style="text-align: right;">Serie 98.6 Total 197.3</p>	<p>60 Skott</p> <p style="text-align: right;">Serie 98.7 Total 98.7</p>
<p>60 Skott</p> <p style="text-align: right;">Serie 95.7 Total 389.7</p>		

Prov 	1: 9.9 ↙ 2: 10.1 ↓ 3: 10.0 → 4: 9.4 → 5: 9.2 → 6: 9.5 ↗ 7: 10.3x → 8: 10.6x ↘ 9: 8.7 → 10: 9.9 ↑ Serie 97.6 Total 0.0	Prov 	11: 10.0 → Serie 10.0 Total 0.0
60 Skott 	1: 9.7 → 2: 10.0 ↗ 3: 9.2 → 4: 9.6 ↑ 5: 10.1 ↗ 6: 9.9 ↓ 7: 9.0 → 8: 10.0 ← 9: 9.3 → 10: 9.0 → Serie 95.8 Total 95.8	60 Skott 	11: 10.2x ↘ 12: 9.5 ↗ 13: 10.3x ↓ 14: 10.1 ↓ 15: 9.0 → 16: 9.7 ↗ 17: 9.3 → 18: 9.4 ↓ 19: 9.6 → 20: 9.4 → Serie 96.5 Total 192.3
60 Skott 	21: 8.8 → 22: 10.0 → 23: 9.9 → 24: 9.8 ↓ 25: 9.5 ↙ 26: 9.8 ↓ 27: 9.8 → 28: 10.2x ↘ 29: 10.7x ↘ 30: 10.3x ↘ Serie 98.8 Total 291.1	60 Skott 	31: 8.6 ← 32: 10.3x ↗ 33: 10.0 ↗ 34: 10.4x ↗ 35: 10.2x ↗ 36: 10.2x ↓ 37: 9.8 ↓ 38: 9.9 ↗ 39: 10.1 ← 40: 10.0 ← Serie 99.5 Total 390.6

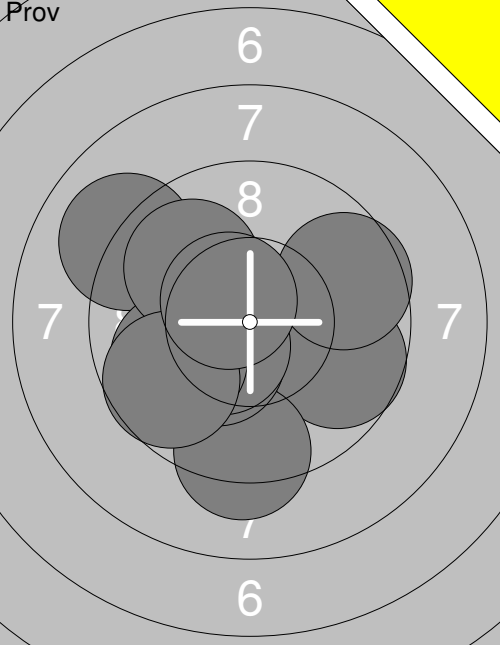
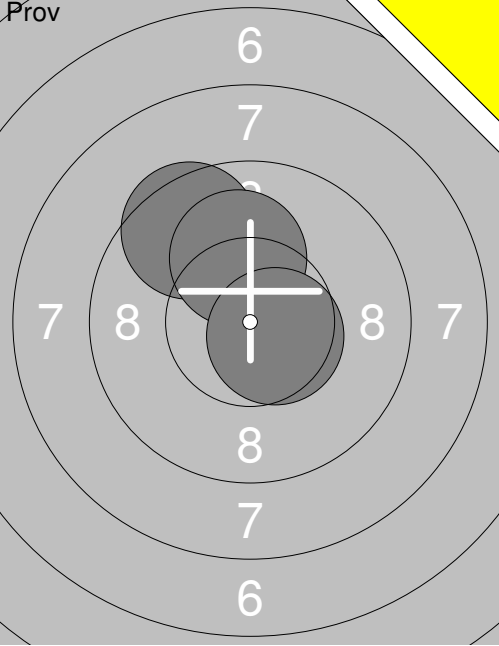
Skjutlag	Tavla	Anna Östman	
2	14		
S	Ramselefors		
13.01.2019	Skyttiaden 2019	Umeå skytteallians	
Prov		Prov	
	1: 9.0 ↖ 2: 9.7 → 3: 9.3 ↓ 4: 10.3x↘ 5: 10.5x↘ 6: 9.9 ← 7: 9.9 ↖ 8: 9.7 ↙ 9: 9.6 → 10: 10.6x↘ Serie 98.5 Total 0.0		11: 9.5 ↖ 12: 10.1 ↑ 13: 10.6x↘ Serie 30.2 Total 0.0
60 Skott	1: 10.0← 2: 9.7 ↙ 3: 9.1 ↖ 4: 8.7 → 5: 9.8 ← 6: 10.7x→ 7: 10.0 → 8: 10.6x↗ 9: 10.7x→ 10: 10.2x↓ Serie 99.5 Total 99.5	60 Skott	11: 10.2x→ 12: 9.8 → 13: 9.8 ↘ 14: 9.4 ← 15: 10.5x↘ 16: 9.8 ↑ 17: 10.5x↘ 18: 10.2x↓ 19: 10.2x↓ 20: 10.5x↘ Serie 100.9 Total 200.4
60 Skott	21: 10.6x↘ 22: 9.3 ↙ 23: 10.3x↘ 24: 10.4x↘ 25: 10.4x↘ 26: 9.7 → 27: 9.6 → 28: 9.1 ↖ 29: 10.1 ↖ 30: 10.4x↗ Serie 99.9 Total 300.3	60 Skott	31: 10.1 ↙ 32: 9.7 ← 33: 10.2x↘ 34: 9.4 ↑ 35: 9.8 ← 36: 9.9 ↑ 37: 9.1 → 38: 10.6x↗ 39: 10.3x↗ 40: 10.8x↓ Serie 99.9 Total 400.2

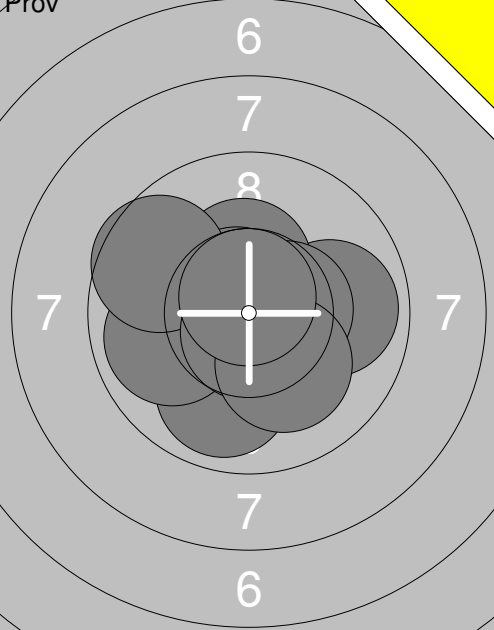
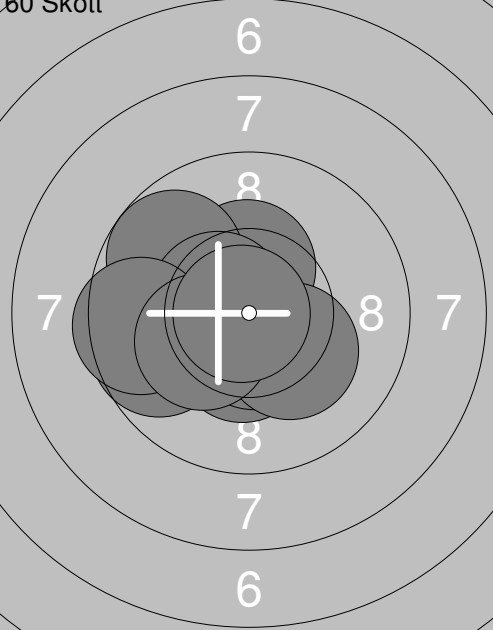
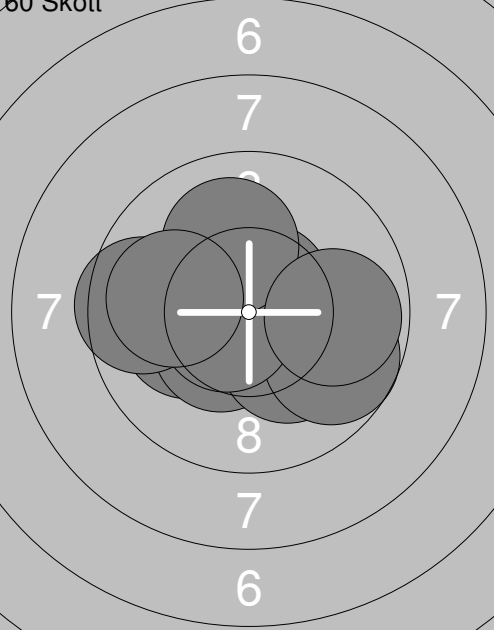
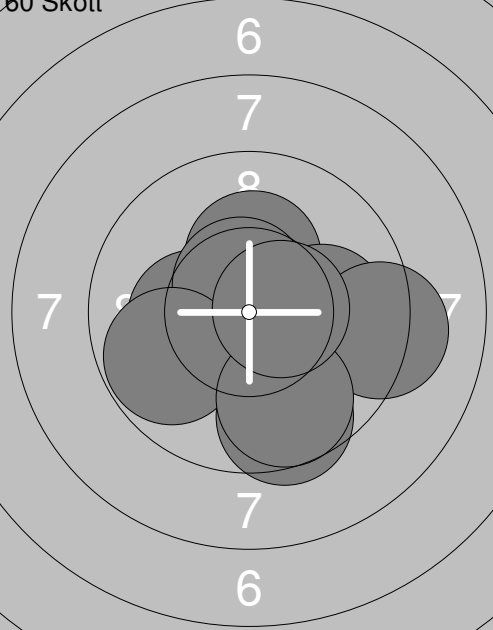
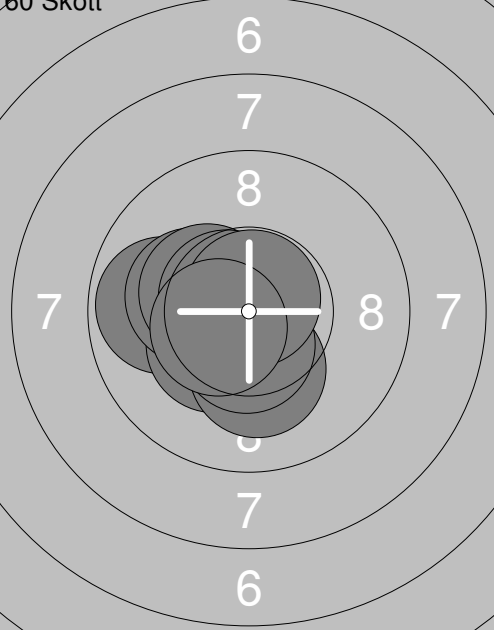
<p>Prov</p>  <p style="text-align: center;">6 7 8 7 6</p>	<p>1: 9.9 →</p> <p>2: 9.9 ↓</p> <p>3: 10.4x↑</p> <p>4: 10.7x↘</p> <p>5: 9.9 ←</p> <p>6: 9.6 ↙</p> <p>7: 10.7x↓</p> <p>8: 10.5x→</p> <p>9: 10.1 ↓</p> <p>10: 10.7x↑</p> <hr/> <p>Serie 102.4</p> <hr/> <p>Total 0.0</p>	<p>60 Skott</p>  <p style="text-align: center;">6 7 8 7 6</p>	<p>1: 10.4x↑</p> <p>2: 9.7 ←</p> <p>3: 9.7 ↖</p> <p>4: 10.5x↖</p> <p>5: 9.5 ←</p> <p>6: 10.4x↓</p> <p>7: 10.6x↓</p> <p>8: 10.2x↘</p> <p>9: 10.2x↙</p> <p>10: 10.8x↖</p> <hr/> <p>Serie 102.0</p> <hr/> <p>Total 102.0</p>
<p>60 Skott</p>  <p style="text-align: center;">6 7 8 7 6</p>	<p>11: 10.1 ←</p> <p>12: 10.4x↙</p> <p>13: 10.6x↗</p> <p>14: 10.2x↘</p> <p>15: 9.7 →</p> <p>16: 10.6x↖</p> <p>17: 9.6 ←</p> <p>18: 10.1 ↑</p> <p>19: 9.9 →</p> <p>20: 10.0 ←</p> <hr/> <p>Serie 101.2</p> <hr/> <p>Total 203.2</p>	<p>60 Skott</p>  <p style="text-align: center;">6 7 8 7 6</p>	<p>21: 9.5 ↓</p> <p>22: 10.5x↖</p> <p>23: 10.3x↑</p> <p>24: 10.3x↖</p> <p>25: 10.0 →</p> <p>26: 10.6x↑</p> <p>27: 9.2 →</p> <p>28: 9.8 ←</p> <p>29: 9.7 ↓</p> <p>30: 10.5x→</p> <hr/> <p>Serie 100.4</p> <hr/> <p>Total 303.6</p>
<p>60 Skott</p>  <p style="text-align: center;">6 7 8 7 6</p>	<p>31: 9.8 ←</p> <p>32: 10.3x↖</p> <p>33: 10.2x↓</p> <p>34: 10.2x↖</p> <p>35: 10.5x↖</p> <p>36: 10.5x↓</p> <p>37: 10.4x↖</p> <p>38: 10.6x↖</p> <p>39: 10.8x↑</p> <p>40: 10.5x↖</p> <hr/> <p>Serie 103.8</p> <hr/> <p>Total 407.4</p>		

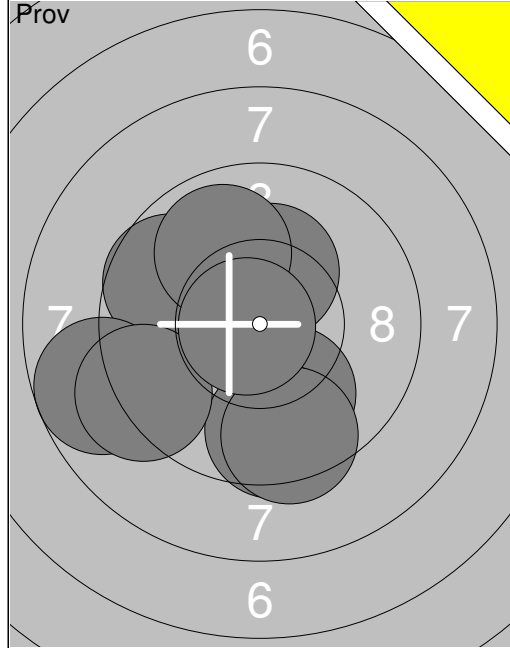

1:	10.3x ↗
2:	10.0 ↓
3:	10.3x ↗
4:	9.7 ↖
5:	9.6 ↓
6:	9.4 ↓
7:	8.7 ↖
8:	9.9 ↗
9:	9.2 ↖
10:	10.8x ↖
<b>Serie</b>	<b>97.9</b>
<b>Total</b>	<b>0.0</b>

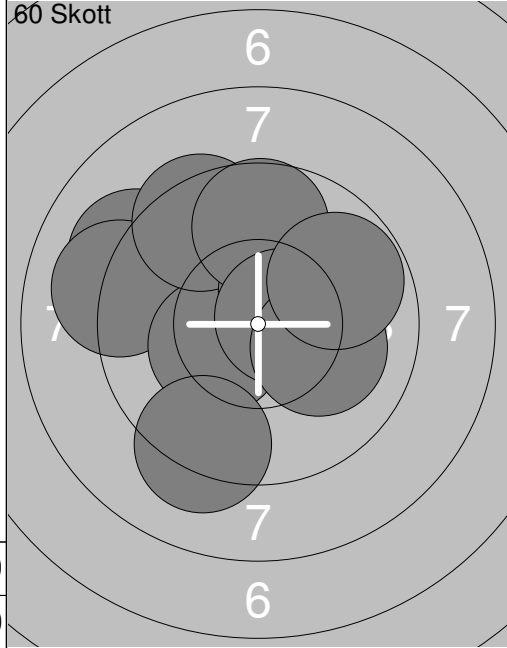

1:	9.1 ↖
2:	9.1 ↖
3:	10.3x ↖
4:	9.4 ↗
5:	10.4x ↗
6:	9.7 ↑
7:	10.6x →
8:	9.2 ↓
9:	10.1 →
10:	9.8 ↗
<b>Serie</b>	<b>97.7</b>
<b>Total</b>	<b>97.7</b>

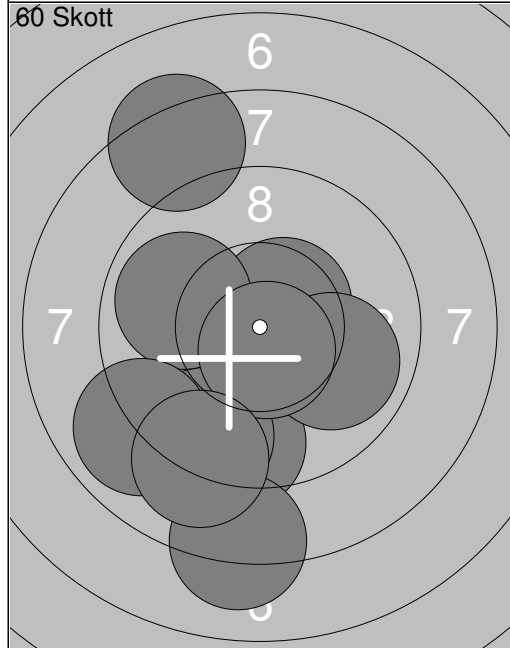

11:	9.4 ↓
12:	10.5x ↗
13:	9.4 ↓
14:	8.1 ↓
15:	9.9 ↖
16:	8.9 ↖
17:	9.9 →
18:	8.3 ↗
19:	10.6x ↓
20:	9.1 ↓
<b>Serie</b>	<b>94.1</b>
<b>Total</b>	<b>191.8</b>

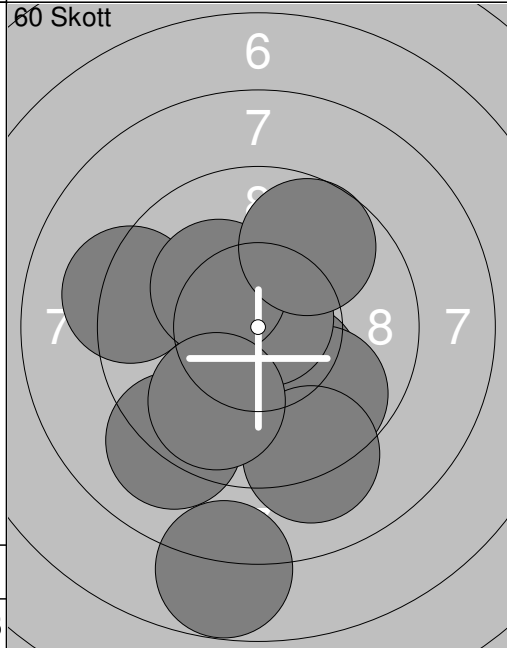

21:	9.2 ↖
22:	10.2x ↘
23:	9.8 ↘
24:	9.1 ↓
25:	10.8x ↗
26:	9.2 ↓
27:	10.2x ↘
28:	9.7 ↗
29:	9.8 ↓
30:	7.8 ↓
<b>Serie</b>	<b>95.8</b>
<b>Total</b>	<b>287.6</b>

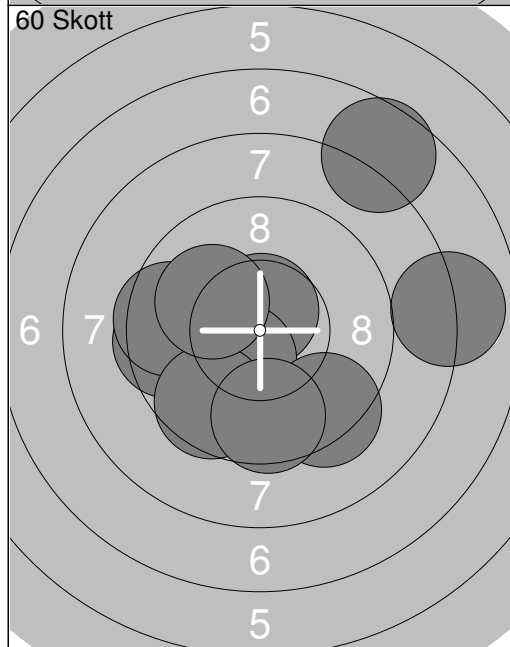

31:	9.5 ↖
32:	9.5 ↖
33:	10.6x ↗
34:	10.4x ↘
35:	9.6 ↓
36:	10.1 ↖
37:	8.0 →
38:	7.6 ↗
39:	9.3 ↓
40:	9.6 ↓
<b>Serie</b>	<b>94.2</b>
<b>Total</b>	<b>381.8</b>

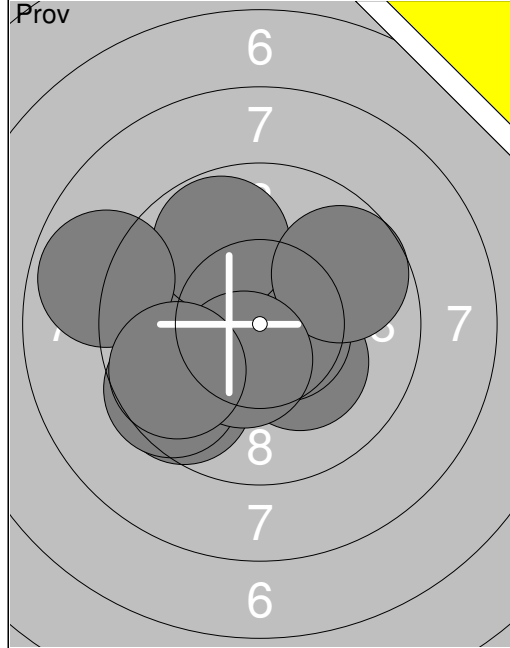

1:	9.6 ↙
2:	9.9 ←
3:	9.5 ↙
4:	10.2x ↘
5:	10.6x →
6:	9.8 ↗
7:	9.7 ↗
8:	10.4x ↘
9:	8.9 ←
10:	9.7 ↙
Serie	98.3
Total	0.0

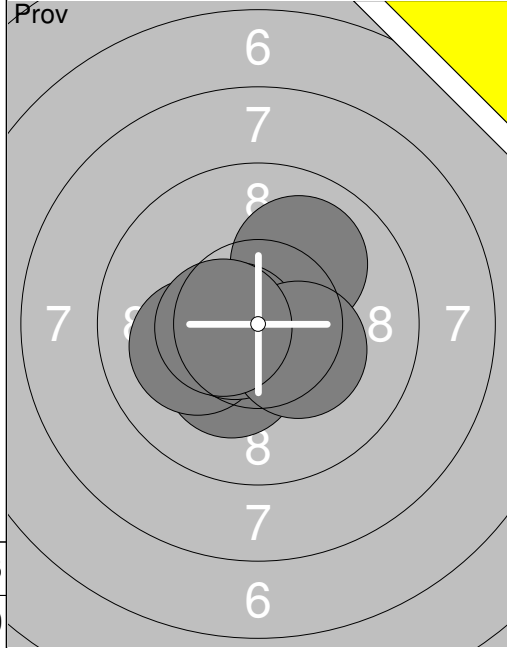

11:	10.3x ↘
12:	10.0 ↗
13:	10.1 ←
14:	10.6x ↘
15:	10.3x ↘
16:	10.5x ←
Serie	61.8
Total	0.0

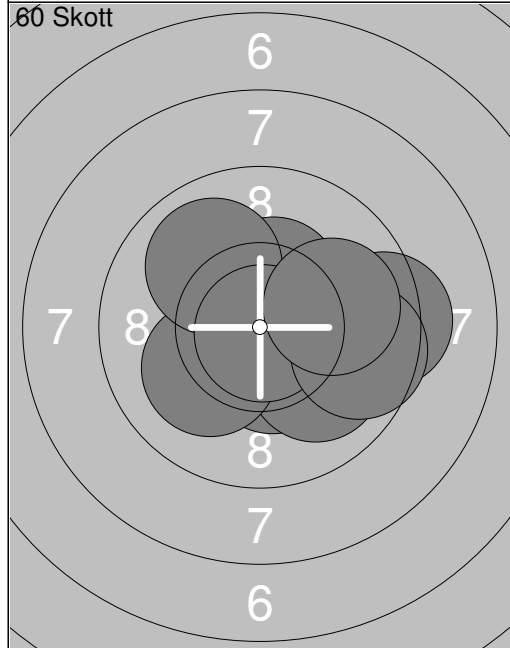

1:	10.6x ↘
2:	10.4x ↘
3:	10.0 ↘
4:	10.1 ↙
5:	10.4x ↗
6:	10.0 ↖
7:	9.3 →
8:	10.9x ↘
9:	9.6 →
10:	10.0 →
Serie	101.3
Total	101.3

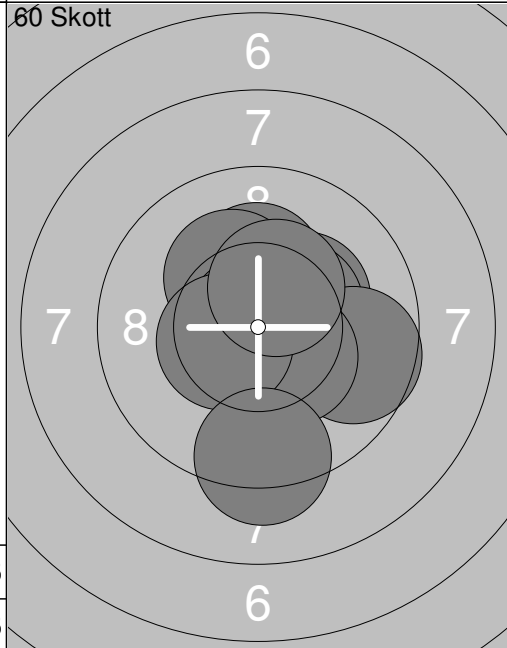

11:	10.3x ↗
12:	10.2x ↗
13:	10.4x ↗
14:	10.2x ↖
15:	9.7 →
16:	10.9x ↘
17:	10.4x ↘
18:	10.5x ↘
19:	10.4x ↗
20:	9.3 ↓
Serie	102.3
Total	203.6

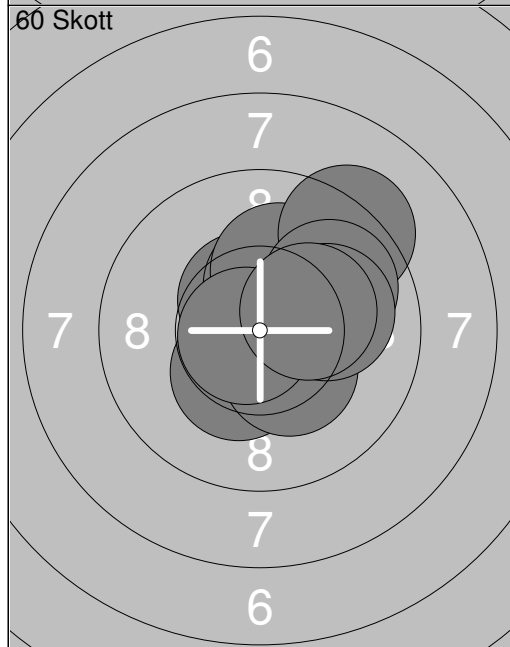

21:	10.5x ↘
22:	10.3x ↘
23:	10.3x ↘
24:	10.3x ↗
25:	10.1 ↗
26:	9.3 ↗
27:	9.9 ↗
28:	10.8x ↘
29:	10.0 →
30:	10.3x ↗
Serie	101.8
Total	305.4

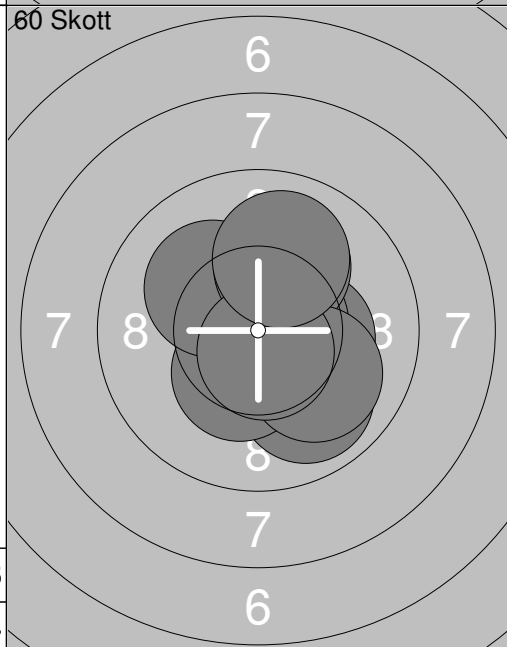

31:	10.3x →
32:	9.9 ↘
33:	10.4x ↘
34:	10.6x ↗
35:	10.6x ↗
36:	10.1 ↖
37:	10.1 ↗
38:	10.0 ↘
39:	10.7x ↘
40:	10.0 ↗
Serie	102.7
Total	408.1

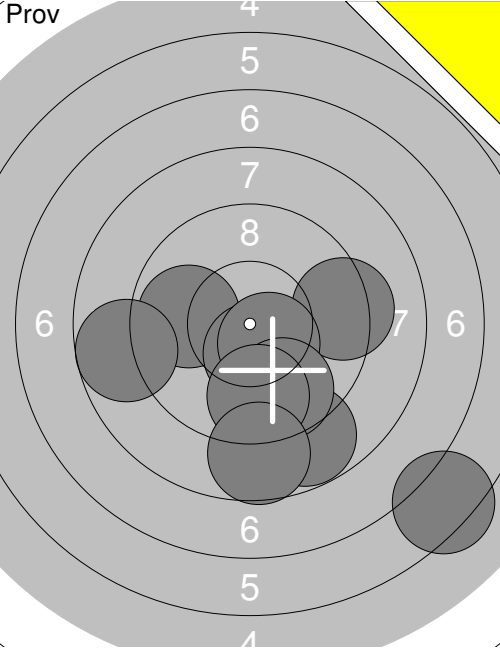
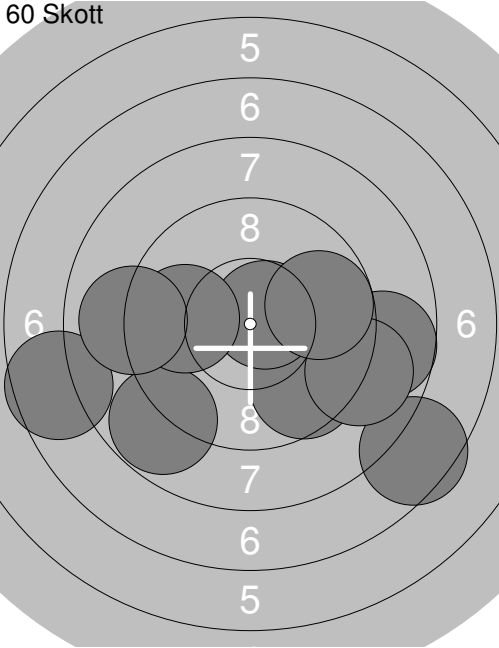
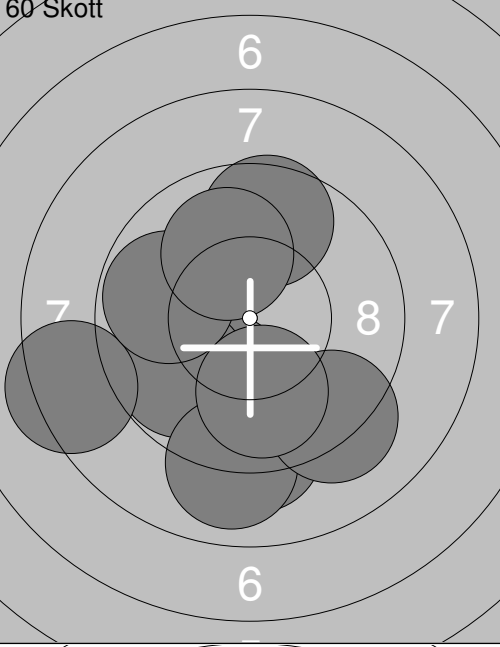
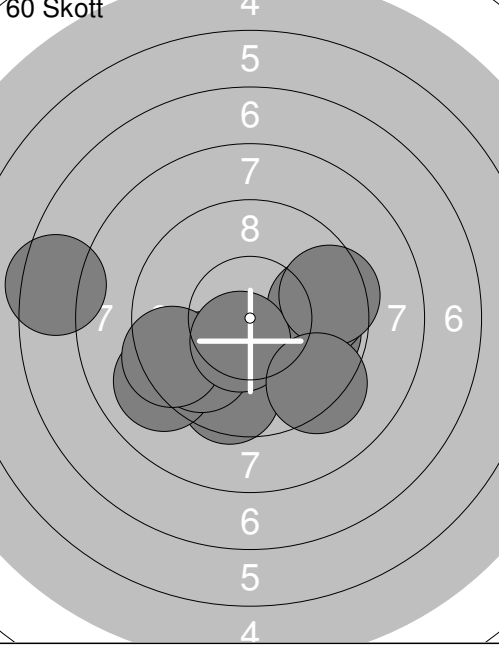
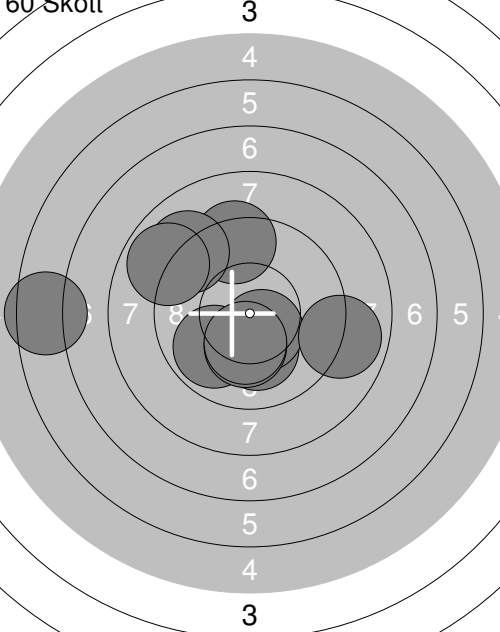
Skjutlag	Tavla	Mats Österlund	
2	20		
S	Ramselefors		
13.01.2019	Skyttiaden 2019	Umeå skytteallians	
Prov		1: 9.9 ← 2: 10.4x↓ 3: 8.8 ↓ 4: 8.7 ← 5: 9.3 → 6: 6.3 ↓ 7: 10.5x↓ 8: 9.7 ↓ 9: 9.7 ↓ 10: 8.7 ↓ Serie 92.0 Total 0.0	60 Skott  1: 9.6 ↘ 2: 8.7 → 3: 10.7x↗ 4: 7.5 ↘ 5: 9.0 → 6: 8.8 ↘ 7: 9.9 ← 8: 7.6 ← 9: 9.8 → 10: 9.0 ← Serie 90.6 Total 90.6
60 Skott		11: 10.1 ↓ 12: 9.8 ↙ 13: 9.2 ↓ 14: 9.6 ↑ 15: 8.4 ← 16: 9.8 ← 17: 9.0 ↓ 18: 9.2 ↓ 19: 10.0 ↑ 20: 9.9 ↓ Serie 95.0 Total 185.6	60 Skott  21: 9.6 ↓ 22: 9.9 → 23: 9.7 → 24: 9.1 ↙ 25: 9.8 ↙ 26: 9.4 ↙ 27: 7.5 ← 28: 10.5x↓ 29: 9.5 → 30: 9.3 ↘ Serie 94.3 Total 279.9
60 Skott		31: 9.4 ↑ 32: 10.2x↓ 33: 9.1 ↖ 34: 8.9 ↙ 35: 10.5x↓ 36: 8.9 → 37: 9.9 ↙ 38: 10.2x↓ 39: 6.5 ← 40: 10.3x↓ Serie 93.9 Total 373.8	

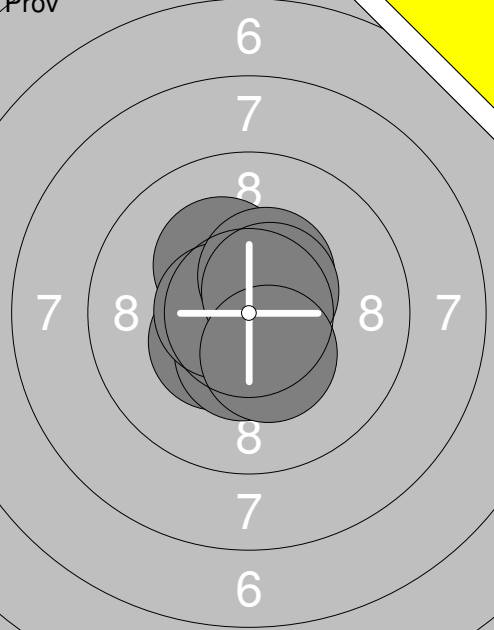
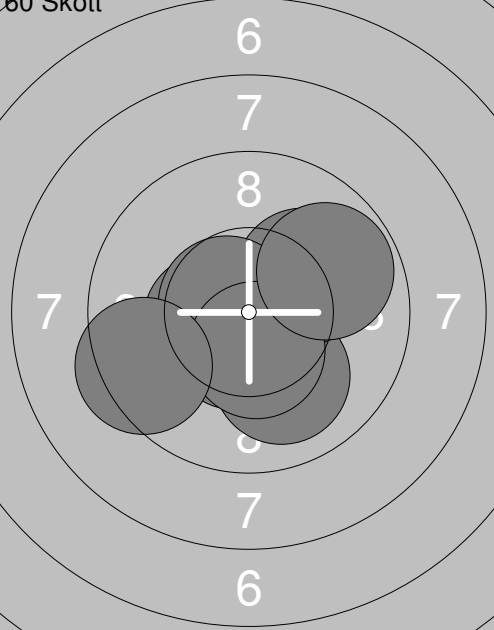
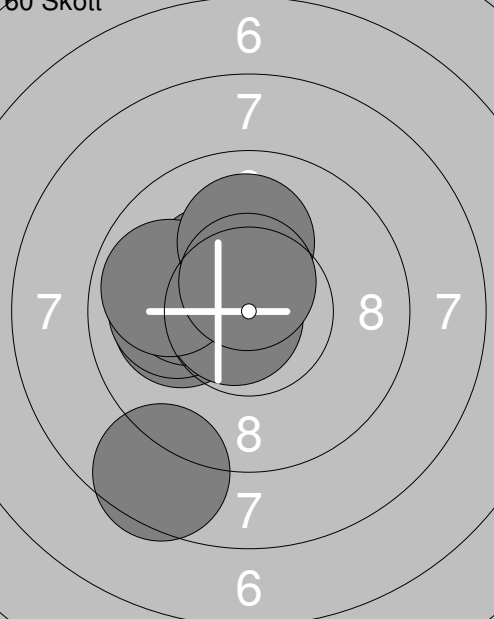

Prov 	1: 10.0 ↑ 2: 10.2x ➤ 3: 10.0 ↑ 4: 10.1 ↖ 5: 10.7x ✕ 6: 10.7x ✕ 7: 9.9 ↑ 8: 10.1 ➤ 9: 9.9 ↓ 10: 10.3x ➤ Serie 101.9 Total 0.0	Prov 	11: 10.5x ✕ 12: 10.6x ↓ 13: 10.4x ↗ 14: 10.4x ✕ Serie 41.9 Total 0.0
60 Skott 	1: 10.7x ➤ 2: 10.8x ✕ 3: 10.5x ✕ 4: 10.7x ➤ 5: 10.8x ↓ 6: 10.5x ➤ 7: 10.1 ↓ 8: 10.8x ➤ 9: 10.2x ↗ 10: 10.2x ✕ Serie 105.3 Total 105.3	60 Skott 	11: 10.6x ↓ 12: 10.7x ➤ 13: 10.4x ➤ 14: 10.5x ↓ 15: 10.6x ↓ 16: 10.7x ↓ 17: 10.4x ↗ 18: 9.8 ➤ 19: 10.6x ✕ 20: 10.0 ↓ Serie 104.3 Total 209.6
60 Skott 	21: 9.9 ↗ 22: 10.5x ➤ 23: 10.1 ↓ 24: 10.6x ✕ 25: 10.7x ↓ 26: 10.5x ✕ 27: 10.0 ➔ 28: 10.2x ↓ 29: 10.7x ↑ 30: 10.1 ↙ Serie 103.3 Total 312.9	60 Skott 	31: 10.5x ↓ 32: 10.7x ✕ 33: 10.2x ↓ 34: 10.5x ↓ 35: 10.3x ➤ 36: 10.0 ↓ 37: 10.5x ↓ 38: 10.6x ↓ 39: 10.6x ✕ 40: 10.6x ➤ Serie 104.5 Total 417.4

<p>Prov</p> 	<p>60 Skott</p> 	<p>60 Skott</p> 
<p>1: 10.4x ↘ 2: 10.9x ↗ 3: 10.8x ↘ 4: 10.6x ↘ 5: 10.2x ↘ 6: 10.4x ↓ 7: 10.6x ← 8: 10.4x ↗ 9: 10.6x ↗ 10: 10.4x ↓</p> <p>Serie 105.3 Total 0.0</p>	<p>11: 10.0 ↓ 12: 10.1 ↗ 13: 10.6x ↓ 14: 10.5x ↓ 15: 10.5x ← 16: 10.7x ↓ 17: 10.6x ← 18: 10.4x ↓ 19: 9.8 ↗ 20: 9.4 ←</p> <p>Serie 102.6 Total 206.4</p>	<p>21: 10.3x ↓ 22: 10.2x ← 23: 10.5x ↓ 24: 10.7x ↘ 25: 10.8x ↗ 26: 9.8 ↖ 27: 10.0 ↗ 28: 10.0 ← 29: 10.0 ↗ 30: 10.0 ←</p> <p>Serie 102.3 Total 308.7</p>
<p>1: 10.3x ↗ 2: 9.9 ↗ 3: 10.7x ↘ 4: 9.9 ↓ 5: 10.6x ↓ 6: 10.7x ↓ 7: 10.1 ↘ 8: 10.4x ↓ 9: 10.8x ← 10: 10.4x ↓</p> <p>Serie 103.8 Total 103.8</p>	<p>31: 8.6 ↓ 32: 10.1 ← 33: 10.0 ← 34: 10.4x ↗ 35: 10.2x ← 36: 10.3x ↘ 37: 10.8x ← 38: 9.9 ← 39: 10.1 ↑ 40: 10.6x ↗</p> <p>Serie 101.0 Total 409.7</p>	

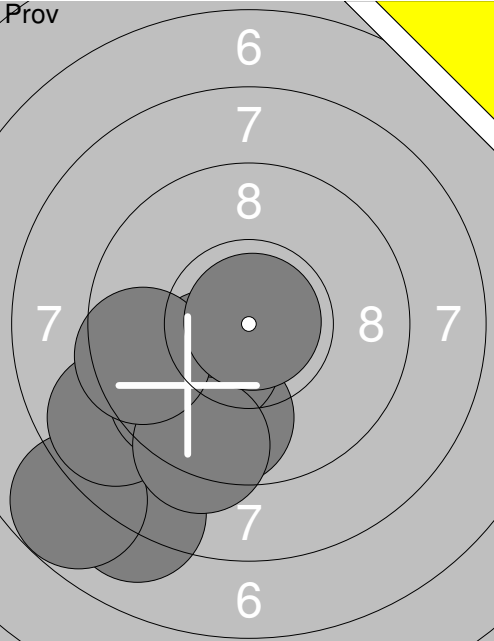
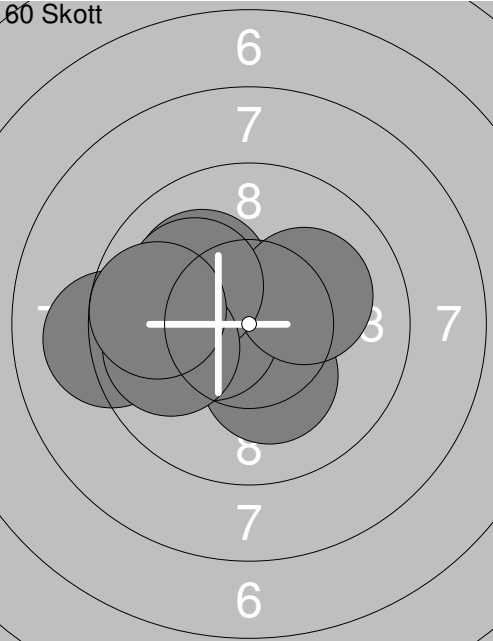
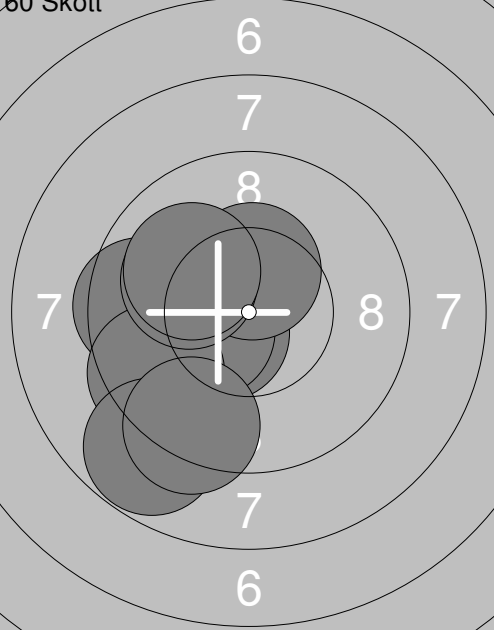
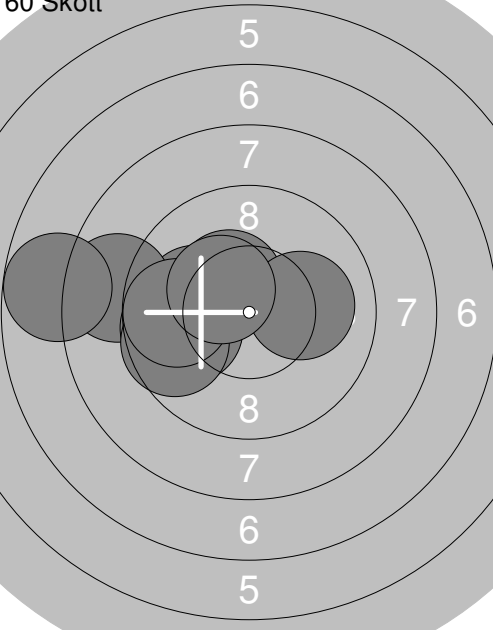
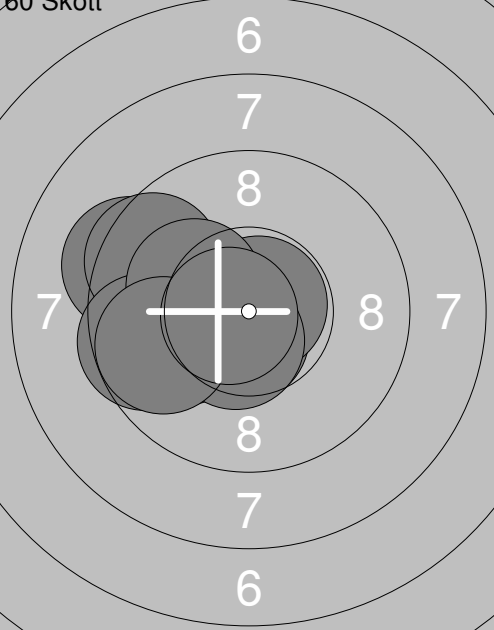
Skjutlag <b>2</b>	Tavla <b>23</b>	<b>Amelia Larsson</b>	
S		Drängsmark	
13.01.2019		Skyttiaden 2019	
Prov		Umeå skytteallians	
	1: 8.1 ↘		1: 10.5x↘
	2: 7.8 ↘		2: 9.9 ←
	3: 9.7 ↘		3: 10.2x↓
	4: 8.8 ↙		4: 9.1 ←
	5: 9.6 ↘		5: 10.4x↘
	6: 10.3x↘		6: 10.1 ↖
	7: 9.3 ↘		7: 10.1 →
	8: 9.5 ←		8: 10.1 ↖
	9: 10.9x↗		9: 9.9 ←
	10: 9.7 ←		10: 9.7 ←
Serie	84.0	Serie	100.0
Total	0.0	Total	100.0
	11: 10.5x↘		21: 10.0 ←
	12: 10.1 ←		22: 8.7 ←
	13: 10.3x↘		23: 9.7 ←
	14: 10.4x↑		24: 9.9 ←
	15: 9.5 ←		25: 10.4x↘
	16: 9.5 ↙		26: 9.6 ←
	17: 8.8 ↘		27: 10.1 →
	18: 9.3 ↘		28: 7.8 ←
	19: 10.1 ↖		29: 9.8 ←
	20: 10.0 ↖		30: 10.4x↘
Serie	98.5	Serie	96.4
Total	198.5	Total	294.9
	31: 10.6x↓		
	32: 9.3 ←		
	33: 10.8x↗		
	34: 9.5 ↖		
	35: 10.0 ←		
	36: 9.6 ←		
	37: 10.2x↘		
	38: 10.5x↓		
	39: 9.7 ←		
	40: 10.7x↘		
Serie	100.9		
Total	395.8		

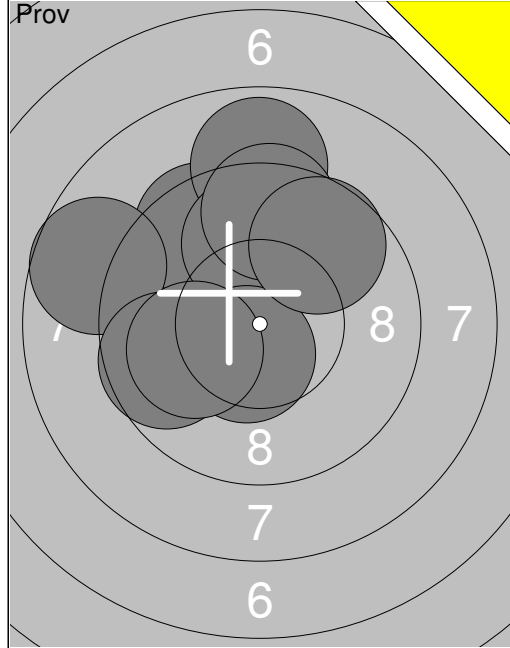

1:	9.5 ↗
2:	8.7 ↖
3:	9.6 ↖
4:	8.9 ↑
5:	10.0 ↑
6:	9.9 ↑
7:	9.5 ↑
8:	10.5x ↘
9:	10.0 ↖
10:	9.7 ↗
<b>Serie</b>	<b>96.3</b>
<b>Total</b>	<b>0.0</b>

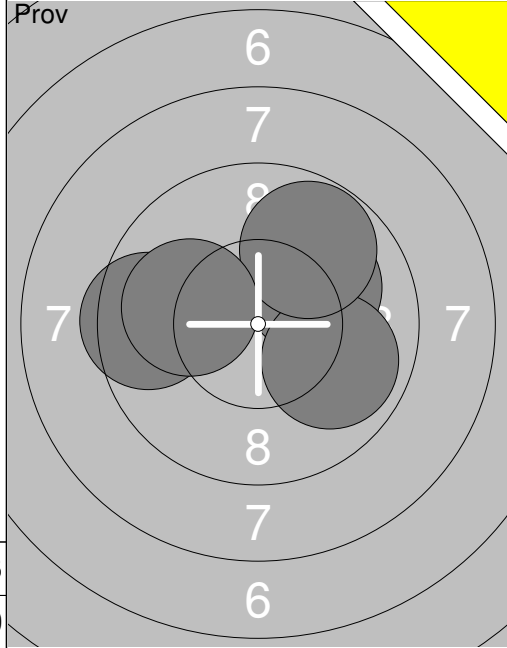

11:	9.5 ↖
12:	10.1 ↗
13:	9.9 ↗
14:	9.8 ↗
15:	10.0 ↖
<b>Serie</b>	<b>49.3</b>
<b>Total</b>	<b>0.0</b>

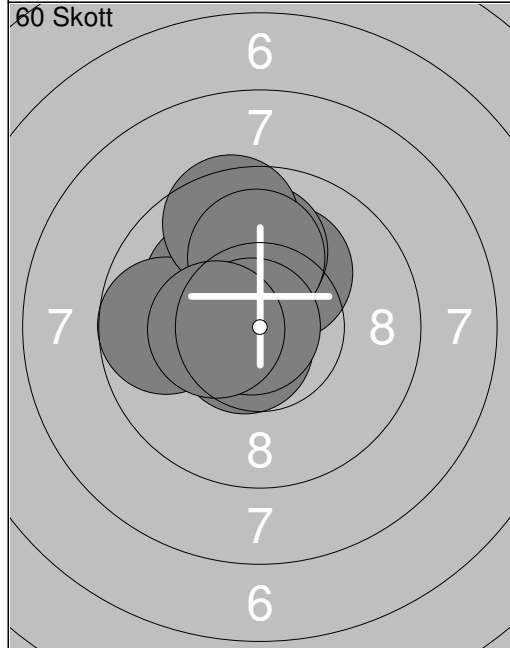

1:	10.3x ↖
2:	10.1 ↖
3:	10.2x ↗
4:	10.6x ↘
5:	10.0 ↑
6:	9.7 ↖
7:	9.5 ↑
8:	10.0 ↑
9:	10.8x ↖
10:	10.4x ↖
<b>Serie</b>	<b>101.6</b>
<b>Total</b>	<b>101.6</b>

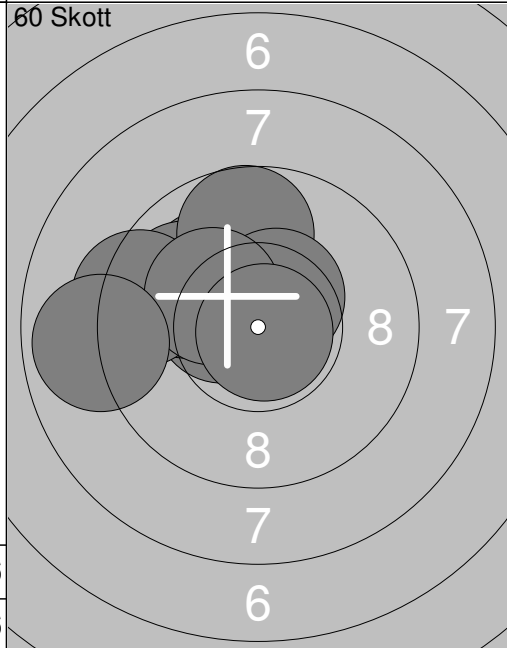

11:	10.1 ↖
12:	10.1 ↑
13:	10.5x ↖
14:	9.9 ↖
15:	9.7 ↑
16:	10.5x ↗
17:	9.4 ↖
18:	10.2x ↖
19:	10.8x ↘
20:	8.9 ↖
<b>Serie</b>	<b>100.1</b>
<b>Total</b>	<b>201.7</b>

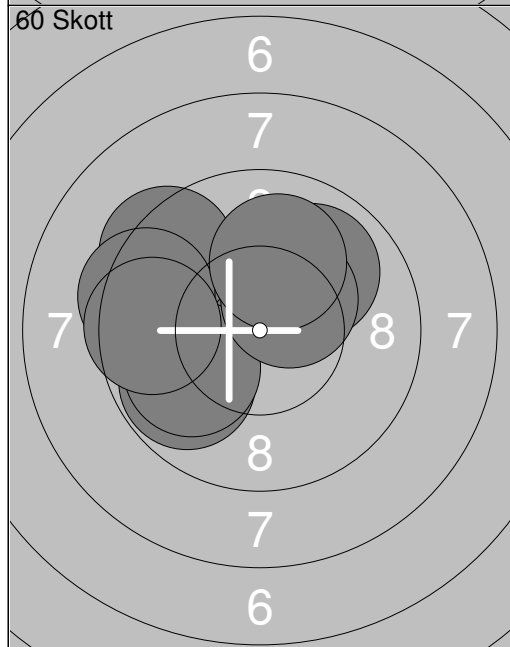

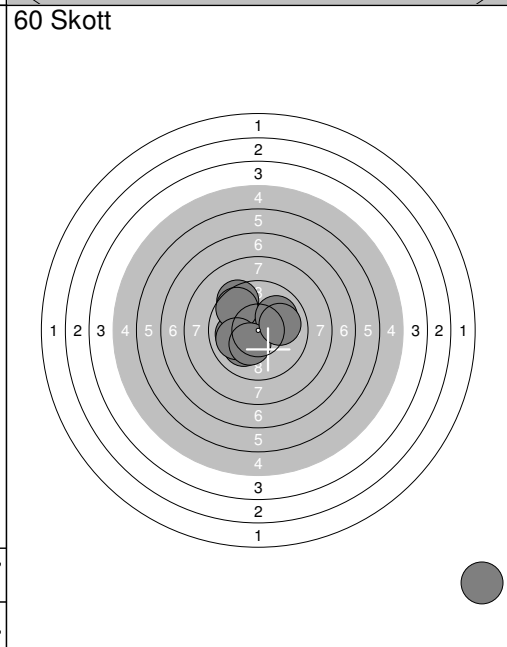

21:	9.8 ↖
22:	9.6 ↖
23:	9.4 ↖
24:	9.8 ↖
25:	9.4 ↖
26:	9.9 ↖
27:	9.9 ↗
28:	10.4x ↗
29:	9.5 ↖
30:	10.0 ↑
<b>Serie</b>	<b>97.7</b>
<b>Total</b>	<b>299.4</b>



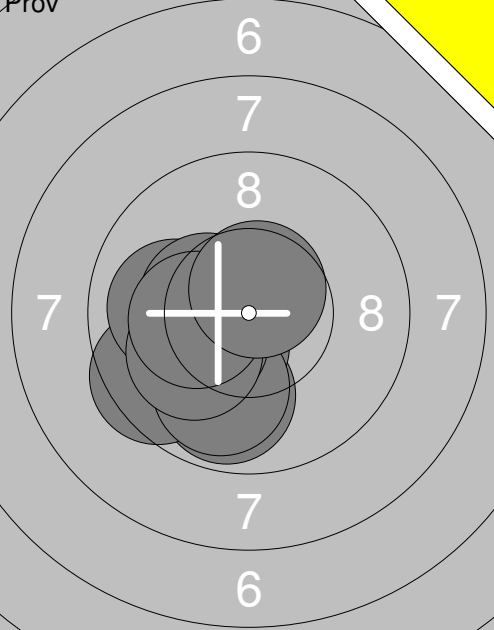

31:	9.4 ↖
32:	10.0 ↖
33:	10.4x ↖
34:	9.7 ↖
35:	0.0 ↘
36:	10.0 ↗
37:	10.1 ↖
38:	10.0 ↖
39:	10.3x ↘
40:	10.0 →
<b>Serie</b>	<b>89.9</b>
<b>Total</b>	<b>389.3</b>

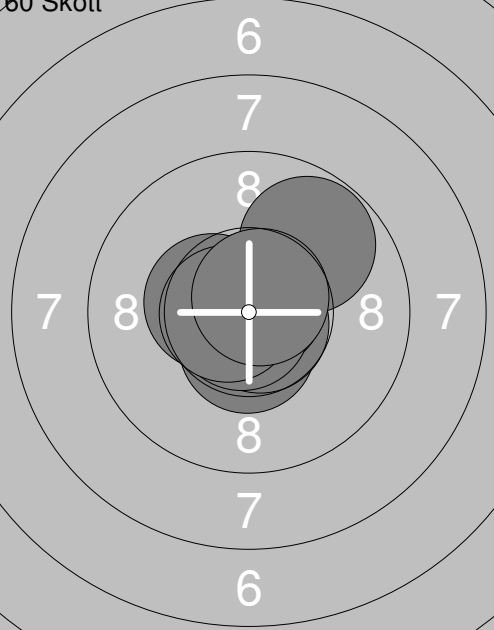
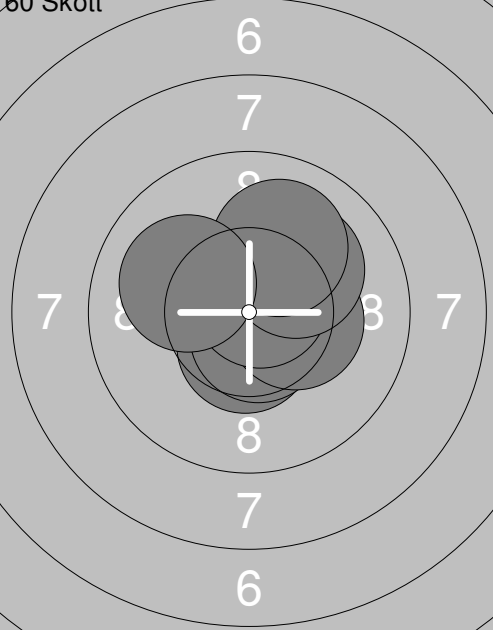
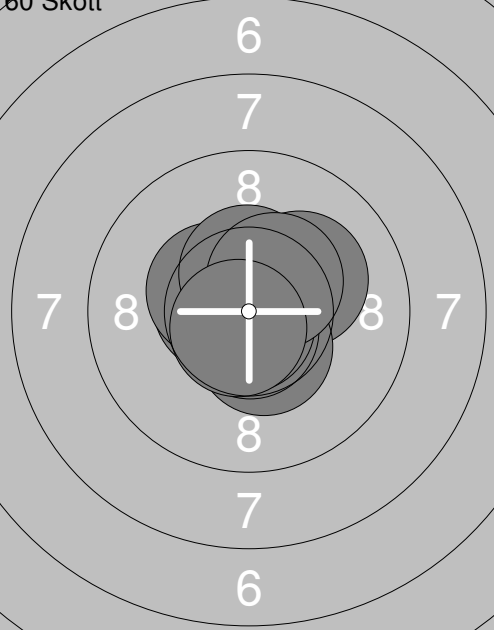
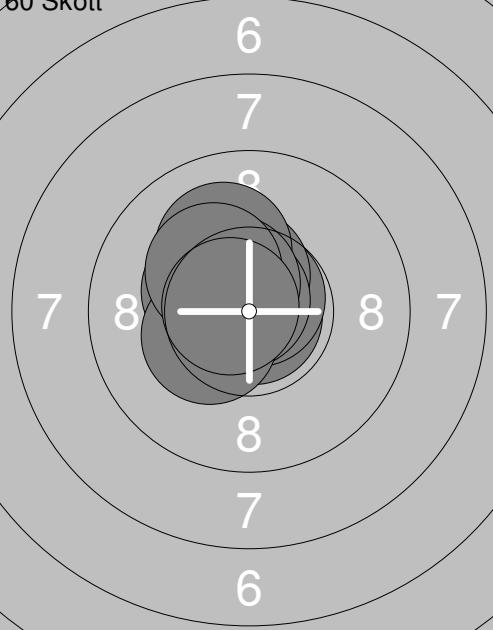
<p>Prov</p>	<p>1: 9.9 ←</p> <p>2: 10.1 ←</p> <p>3: 9.6 ↓</p> <p>4: 10.2x →</p> <p>5: 10.2x ↓</p> <p>6: 10.5x ↑</p> <p>7: 10.1 ↘</p> <p>8: 10.5x →</p> <p>9: 9.8 ↓</p> <p>10: 10.4x ↓</p> <p>Serie 101.3</p> <p>Total 0.0</p>	<p>Prov</p>	<p>11: 10.3x ↑</p> <p>12: 10.5x ↓</p> <p>13: 10.8x ↓</p> <p>14: 10.7x →</p> <p>Serie 42.3</p> <p>Total 0.0</p>
<p>60 Skott</p>	<p>1: 10.8x ↓</p> <p>2: 10.7x ↓</p> <p>3: 10.8x →</p> <p>4: 10.8x ↓</p> <p>5: 10.4x →</p> <p>6: 10.5x ↓</p> <p>7: 10.5x ↓</p> <p>8: 10.1 →</p> <p>9: 10.3x ↓</p> <p>10: 10.5x ↘</p> <p>Serie 105.4</p> <p>Total 105.4</p>	<p>60 Skott</p>	<p>11: 10.6x →</p> <p>12: 10.3x ↓</p> <p>13: 10.8x →</p> <p>14: 10.6x ↘</p> <p>15: 10.6x ↓</p> <p>16: 10.5x →</p> <p>17: 10.9x ↓</p> <p>18: 10.4x →</p> <p>19: 10.7x →</p> <p>20: 10.4x ↘</p> <p>Serie 105.8</p> <p>Total 211.2</p>
<p>60 Skott</p>	<p>21: 10.2x ↘</p> <p>22: 10.2x ↘</p> <p>23: 10.7x ↘</p> <p>24: 10.8x ↘</p> <p>25: 10.6x ↘</p> <p>26: 10.3x ↓</p> <p>27: 10.2x ↓</p> <p>28: 10.8x ↑</p> <p>29: 10.5x ↓</p> <p>30: 10.5x ↘</p> <p>Serie 104.8</p> <p>Total 316.0</p>	<p>60 Skott</p>	<p>31: 10.6x →</p> <p>32: 10.7x ↘</p> <p>33: 10.6x ↗</p> <p>34: 10.3x ↑</p> <p>35: 10.5x ↘</p> <p>36: 10.8x ↓</p> <p>37: 10.2x ↘</p> <p>38: 10.2x ↘</p> <p>39: 10.4x ↓</p> <p>40: 10.5x ↑</p> <p>Serie 104.8</p> <p>Total 420.8</p>

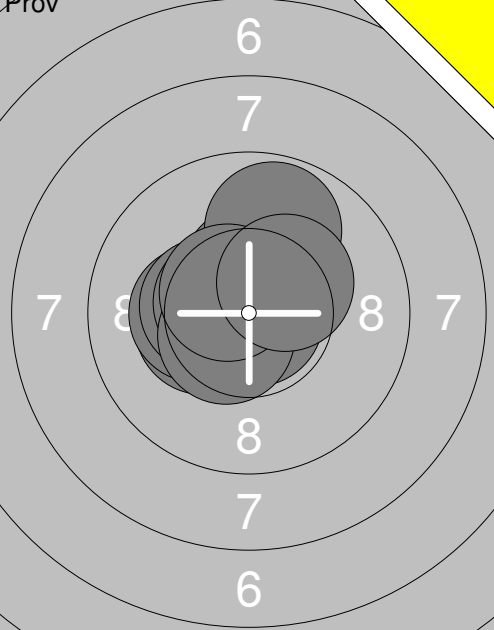
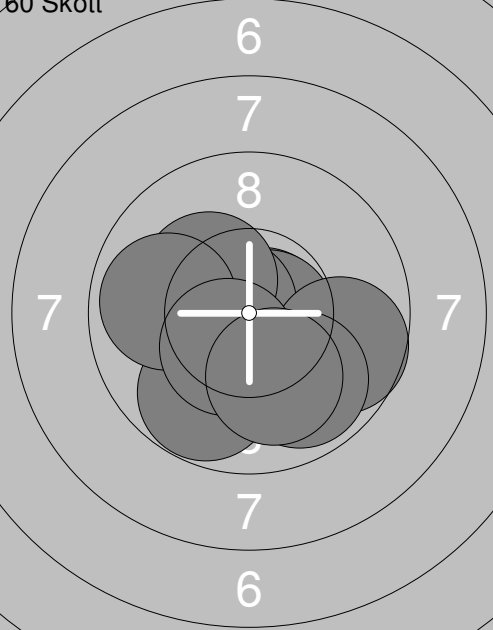
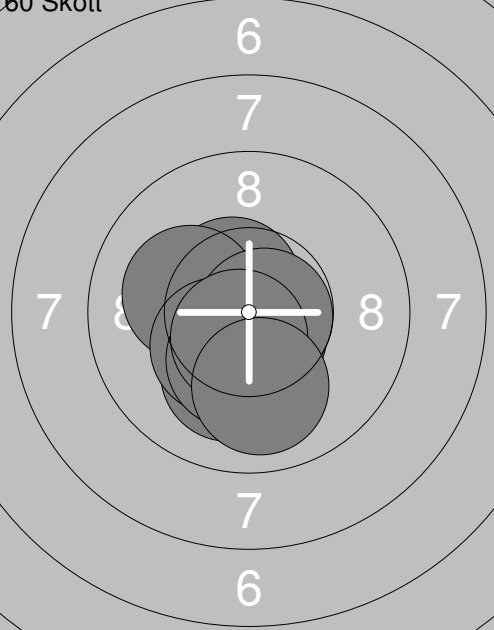
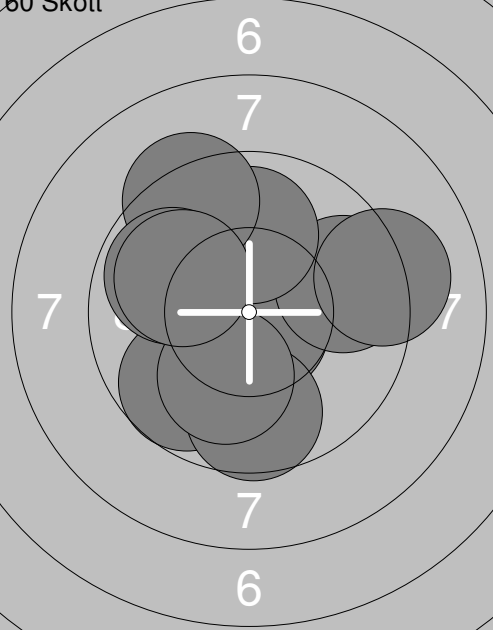
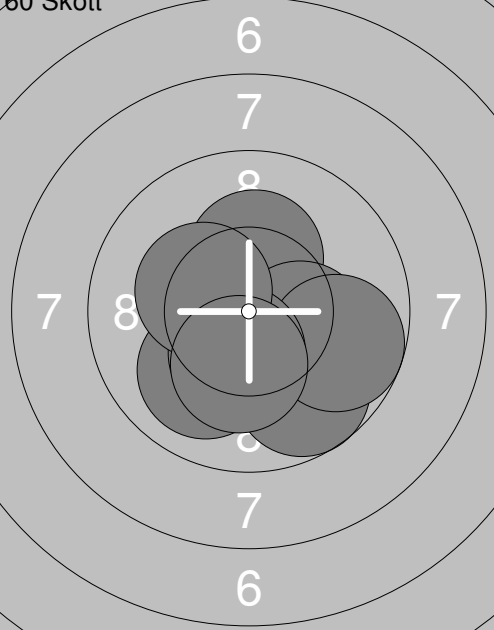
<p>Prov</p> 	<p>1: 9.8 ↓ 2: 10.4x↘ 3: 9.5 ↙ 4: 9.9 ↓ 5: 10.0 ← 6: 10.2x↘ 7: 10.4x↘ 8: 10.1 ↙ 9: 10.3x↘ 10: 10.6x↗</p> <p>Serie 101.2 Total 0.0</p>	<p>Prov</p> 	<p>11: 10.7x↗ 12: 10.5x↗</p> <p>Serie 21.2 Total 0.0</p>
<p>60 Skott</p> 	<p>1: 10.8x↗ 2: 10.5x↓ 3: 10.7x↘ 4: 10.8x↘ 5: 10.8x↗ 6: 10.8x↘ 7: 10.5x↘ 8: 10.7x↘ 9: 9.8 ↗ 10: 10.7x↗</p> <p>Serie 106.1 Total 106.1</p>	<p>60 Skott</p> 	<p>11: 10.5x↓ 12: 10.8x→ 13: 10.7x↗ 14: 10.9x↗ 15: 10.6x↓ 16: 10.3x→ 17: 10.7x↗ 18: 10.1 ↗ 19: 10.0 ↗ 20: 10.1 ↙</p> <p>Serie 104.7 Total 210.8</p>
<p>60 Skott</p> 	<p>21: 10.6x↘ 22: 10.4x↘ 23: 10.5x↗ 24: 10.5x↗ 25: 10.2x↗ 26: 10.5x↓ 27: 10.7x↓ 28: 10.8x↓ 29: 10.4x↗ 30: 10.7x↓</p> <p>Serie 105.3 Total 316.1</p>	<p>60 Skott</p> 	<p>31: 10.9x↓ 32: 10.7x↗ 33: 10.5x↗ 34: 10.8x↘ 35: 10.1 ↗ 36: 10.4x↘ 37: 10.5x↘ 38: 10.3x↘ 39: 10.3x↘ 40: 10.7x↘</p> <p>Serie 105.2 Total 421.3</p>

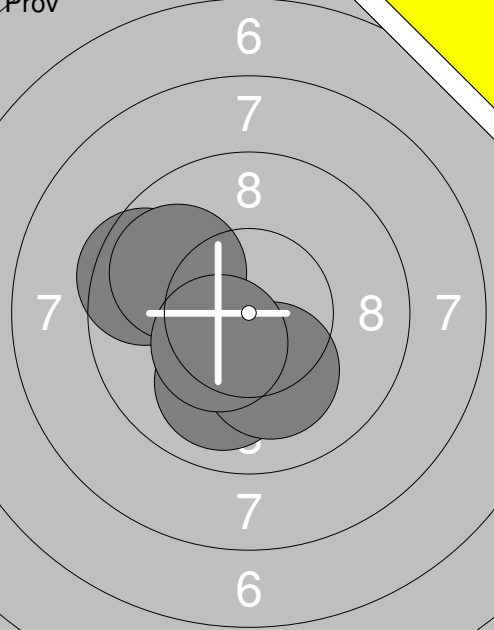
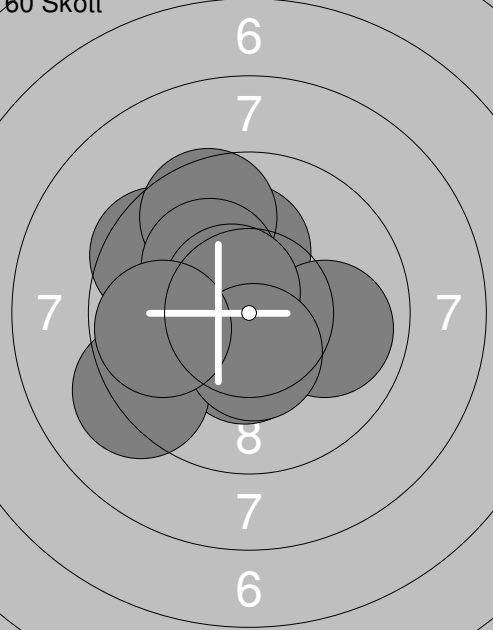
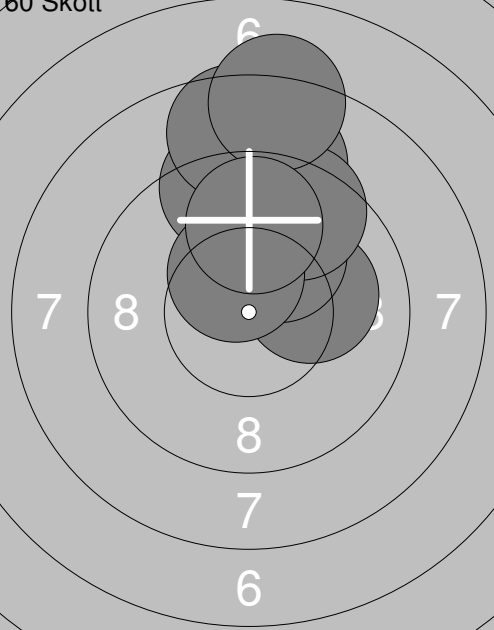
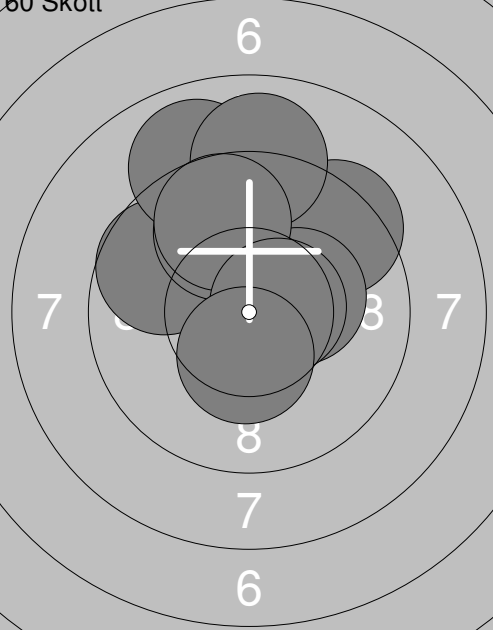
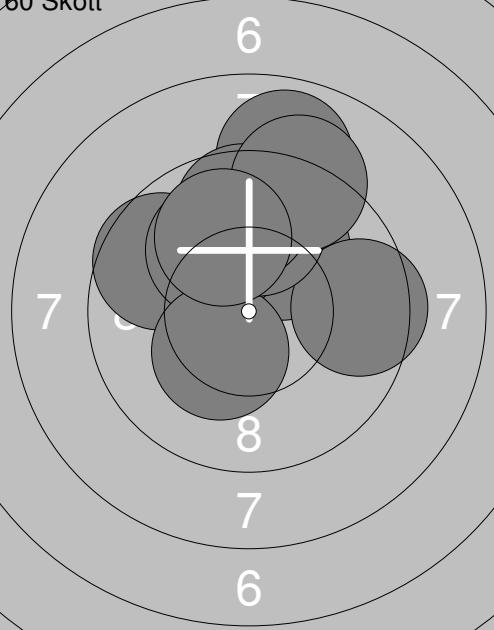
<p>Prov</p> 	<p>60 Skott</p> 	<table style="width:100%; border-collapse: collapse;"> <tr><td>1:</td><td>10.3x↘</td><td>1:</td><td>9.8 ↙</td></tr> <tr><td>2:</td><td>10.8x↘</td><td>2:</td><td>10.8x➤</td></tr> <tr><td>3:</td><td>10.3x↘</td><td>3:</td><td>10.7x➤</td></tr> <tr><td>4:</td><td>10.4x↑</td><td>4:</td><td>10.7x↘</td></tr> <tr><td>5:</td><td>10.4x↘</td><td>5:</td><td>9.7 ➤</td></tr> <tr><td>6:</td><td>10.6x↘</td><td>6:</td><td>9.9 ↙</td></tr> <tr><td>7:</td><td>9.8 ↑</td><td>7:</td><td>10.3x↘</td></tr> <tr><td>8:</td><td>10.5x↘</td><td>8:</td><td>9.9 ←</td></tr> <tr><td>9:</td><td>10.6x↘</td><td>9:</td><td>10.4x↘</td></tr> <tr><td>10:</td><td>10.3x↗</td><td>10:</td><td>10.1 ↙</td></tr> <tr><td colspan="2"><b>Serie 104.0</b></td><td colspan="2"><b>Serie 102.3</b></td></tr> <tr><td colspan="2"><b>Total 0.0</b></td><td colspan="2"><b>Total 102.3</b></td></tr> </table>	1:	10.3x↘	1:	9.8 ↙	2:	10.8x↘	2:	10.8x➤	3:	10.3x↘	3:	10.7x➤	4:	10.4x↑	4:	10.7x↘	5:	10.4x↘	5:	9.7 ➤	6:	10.6x↘	6:	9.9 ↙	7:	9.8 ↑	7:	10.3x↘	8:	10.5x↘	8:	9.9 ←	9:	10.6x↘	9:	10.4x↘	10:	10.3x↗	10:	10.1 ↙	<b>Serie 104.0</b>		<b>Serie 102.3</b>		<b>Total 0.0</b>		<b>Total 102.3</b>	
1:	10.3x↘	1:	9.8 ↙																																															
2:	10.8x↘	2:	10.8x➤																																															
3:	10.3x↘	3:	10.7x➤																																															
4:	10.4x↑	4:	10.7x↘																																															
5:	10.4x↘	5:	9.7 ➤																																															
6:	10.6x↘	6:	9.9 ↙																																															
7:	9.8 ↑	7:	10.3x↘																																															
8:	10.5x↘	8:	9.9 ←																																															
9:	10.6x↘	9:	10.4x↘																																															
10:	10.3x↗	10:	10.1 ↙																																															
<b>Serie 104.0</b>		<b>Serie 102.3</b>																																																
<b>Total 0.0</b>		<b>Total 102.3</b>																																																
<p>60 Skott</p> 	<p>60 Skott</p> 	<table style="width:100%; border-collapse: collapse;"> <tr><td>11:</td><td>10.2x↘</td><td>21:</td><td>10.7x↘</td></tr> <tr><td>12:</td><td>10.6x↘</td><td>22:</td><td>9.7 ↙</td></tr> <tr><td>13:</td><td>10.5x↘</td><td>23:</td><td>9.6 ↙</td></tr> <tr><td>14:</td><td>10.1 ↙</td><td>24:</td><td>9.7 ➤</td></tr> <tr><td>15:</td><td>10.2x↘</td><td>25:</td><td>9.2 ➤</td></tr> <tr><td>16:</td><td>10.4x↘</td><td>26:</td><td>9.9 ↑</td></tr> <tr><td>17:</td><td>10.3x↘</td><td>27:</td><td>10.1 ↙</td></tr> <tr><td>18:</td><td>10.7x➤</td><td>28:</td><td>9.3 ↗</td></tr> <tr><td>19:</td><td>10.6x↘</td><td>29:</td><td>9.8 ↙</td></tr> <tr><td>20:</td><td>10.0 ↙</td><td>30:</td><td>10.0↘</td></tr> <tr><td colspan="2"><b>Serie 103.6</b></td><td colspan="2"><b>Serie 98.0</b></td></tr> <tr><td colspan="2"><b>Total 205.9</b></td><td colspan="2"><b>Total 303.9</b></td></tr> </table>	11:	10.2x↘	21:	10.7x↘	12:	10.6x↘	22:	9.7 ↙	13:	10.5x↘	23:	9.6 ↙	14:	10.1 ↙	24:	9.7 ➤	15:	10.2x↘	25:	9.2 ➤	16:	10.4x↘	26:	9.9 ↑	17:	10.3x↘	27:	10.1 ↙	18:	10.7x➤	28:	9.3 ↗	19:	10.6x↘	29:	9.8 ↙	20:	10.0 ↙	30:	10.0↘	<b>Serie 103.6</b>		<b>Serie 98.0</b>		<b>Total 205.9</b>		<b>Total 303.9</b>	
11:	10.2x↘	21:	10.7x↘																																															
12:	10.6x↘	22:	9.7 ↙																																															
13:	10.5x↘	23:	9.6 ↙																																															
14:	10.1 ↙	24:	9.7 ➤																																															
15:	10.2x↘	25:	9.2 ➤																																															
16:	10.4x↘	26:	9.9 ↑																																															
17:	10.3x↘	27:	10.1 ↙																																															
18:	10.7x➤	28:	9.3 ↗																																															
19:	10.6x↘	29:	9.8 ↙																																															
20:	10.0 ↙	30:	10.0↘																																															
<b>Serie 103.6</b>		<b>Serie 98.0</b>																																																
<b>Total 205.9</b>		<b>Total 303.9</b>																																																
<p>60 Skott</p> 	<table style="width:100%; border-collapse: collapse;"> <tr><td>31:</td><td>9.7 ↙</td></tr> <tr><td>32:</td><td>10.6x↘</td></tr> <tr><td>33:</td><td>10.7x↘</td></tr> <tr><td>34:</td><td>10.3x↑</td></tr> <tr><td>35:</td><td>10.2x➤</td></tr> <tr><td>36:</td><td>9.7 ➤</td></tr> <tr><td>37:</td><td>10.0 ↙</td></tr> <tr><td>38:</td><td>10.4x↘</td></tr> <tr><td>39:</td><td>10.3x↘</td></tr> <tr><td>40:</td><td>10.3x↘</td></tr> <tr><td colspan="2"><b>Serie 102.2</b></td></tr> <tr><td colspan="2"><b>Total 406.1</b></td></tr> </table>	31:	9.7 ↙	32:	10.6x↘	33:	10.7x↘	34:	10.3x↑	35:	10.2x➤	36:	9.7 ➤	37:	10.0 ↙	38:	10.4x↘	39:	10.3x↘	40:	10.3x↘	<b>Serie 102.2</b>		<b>Total 406.1</b>																										
31:	9.7 ↙																																																	
32:	10.6x↘																																																	
33:	10.7x↘																																																	
34:	10.3x↑																																																	
35:	10.2x➤																																																	
36:	9.7 ➤																																																	
37:	10.0 ↙																																																	
38:	10.4x↘																																																	
39:	10.3x↘																																																	
40:	10.3x↘																																																	
<b>Serie 102.2</b>																																																		
<b>Total 406.1</b>																																																		

<p>Prov</p> 	<p>60 Skott</p> 	<table style="width:100%; border-collapse: collapse;"> <tr><td>1:</td><td>9.5</td><td>↖</td></tr> <tr><td>2:</td><td>10.0</td><td>↓</td></tr> <tr><td>3:</td><td>10.1</td><td>↓</td></tr> <tr><td>4:</td><td>9.9</td><td>↖</td></tr> <tr><td>5:</td><td>10.4</td><td>↘</td></tr> </table> <table style="width:100%; border-collapse: collapse; margin-top: 5px;"> <tr><td style="border-top: 1px solid black;">Serie</td><td style="border-top: 1px solid black;">49.9</td></tr> <tr><td style="border-top: 1px solid black;">Total</td><td style="border-top: 1px solid black;">0.0</td></tr> </table>	1:	9.5	↖	2:	10.0	↓	3:	10.1	↓	4:	9.9	↖	5:	10.4	↘	Serie	49.9	Total	0.0															
1:	9.5	↖																																		
2:	10.0	↓																																		
3:	10.1	↓																																		
4:	9.9	↖																																		
5:	10.4	↘																																		
Serie	49.9																																			
Total	0.0																																			
<p>60 Skott</p> 	<p>60 Skott</p> 	<table style="width:100%; border-collapse: collapse;"> <tr><td>6:</td><td>9.6</td><td>↖</td></tr> <tr><td>7:</td><td>10.1</td><td>↑</td></tr> <tr><td>8:</td><td>9.6</td><td>↖</td></tr> <tr><td>9:</td><td>10.4</td><td>↘</td></tr> <tr><td>10:</td><td>9.9</td><td>→</td></tr> <tr><td>11:</td><td>9.2</td><td>↖</td></tr> <tr><td>12:</td><td>10.2</td><td>↘</td></tr> <tr><td>13:</td><td>10.6</td><td>↘</td></tr> <tr><td>14:</td><td>10.4</td><td>↘</td></tr> <tr><td>15:</td><td>9.8</td><td>←</td></tr> </table> <table style="width:100%; border-collapse: collapse; margin-top: 5px;"> <tr><td style="border-top: 1px solid black;">Serie</td><td style="border-top: 1px solid black;">99.8</td></tr> <tr><td style="border-top: 1px solid black;">Total</td><td style="border-top: 1px solid black;">99.8</td></tr> </table>	6:	9.6	↖	7:	10.1	↑	8:	9.6	↖	9:	10.4	↘	10:	9.9	→	11:	9.2	↖	12:	10.2	↘	13:	10.6	↘	14:	10.4	↘	15:	9.8	←	Serie	99.8	Total	99.8
6:	9.6	↖																																		
7:	10.1	↑																																		
8:	9.6	↖																																		
9:	10.4	↘																																		
10:	9.9	→																																		
11:	9.2	↖																																		
12:	10.2	↘																																		
13:	10.6	↘																																		
14:	10.4	↘																																		
15:	9.8	←																																		
Serie	99.8																																			
Total	99.8																																			
<p>60 Skott</p> 	<p>60 Skott</p> 	<table style="width:100%; border-collapse: collapse;"> <tr><td>16:</td><td>10.1</td><td>→</td></tr> <tr><td>17:</td><td>9.3</td><td>↑</td></tr> <tr><td>18:</td><td>9.3</td><td>↑</td></tr> <tr><td>19:</td><td>10.1</td><td>↗</td></tr> <tr><td>20:</td><td>9.0</td><td>↑</td></tr> <tr><td>21:</td><td>8.6</td><td>↑</td></tr> <tr><td>22:</td><td>9.5</td><td>↗</td></tr> <tr><td>23:</td><td>8.2</td><td>↑</td></tr> <tr><td>24:</td><td>10.4</td><td>↘</td></tr> <tr><td>25:</td><td>9.8</td><td>↑</td></tr> </table> <table style="width:100%; border-collapse: collapse; margin-top: 5px;"> <tr><td style="border-top: 1px solid black;">Serie</td><td style="border-top: 1px solid black;">94.3</td></tr> <tr><td style="border-top: 1px solid black;">Total</td><td style="border-top: 1px solid black;">194.1</td></tr> </table>	16:	10.1	→	17:	9.3	↑	18:	9.3	↑	19:	10.1	↗	20:	9.0	↑	21:	8.6	↑	22:	9.5	↗	23:	8.2	↑	24:	10.4	↘	25:	9.8	↑	Serie	94.3	Total	194.1
16:	10.1	→																																		
17:	9.3	↑																																		
18:	9.3	↑																																		
19:	10.1	↗																																		
20:	9.0	↑																																		
21:	8.6	↑																																		
22:	9.5	↗																																		
23:	8.2	↑																																		
24:	10.4	↘																																		
25:	9.8	↑																																		
Serie	94.3																																			
Total	194.1																																			
<p>60 Skott</p>	<p>60 Skott</p>	<table style="width:100%; border-collapse: collapse;"> <tr><td>26:</td><td>9.7</td><td>↖</td></tr> <tr><td>27:</td><td>9.9</td><td>↑</td></tr> <tr><td>28:</td><td>9.4</td><td>↗</td></tr> <tr><td>29:</td><td>9.8</td><td>↑</td></tr> <tr><td>30:</td><td>10.3</td><td>↗</td></tr> <tr><td>31:</td><td>8.9</td><td>↑</td></tr> <tr><td>32:</td><td>9.0</td><td>↑</td></tr> <tr><td>33:</td><td>9.7</td><td>↑</td></tr> <tr><td>34:</td><td>10.6</td><td>↗</td></tr> <tr><td>35:</td><td>10.4</td><td>↘</td></tr> </table> <table style="width:100%; border-collapse: collapse; margin-top: 5px;"> <tr><td style="border-top: 1px solid black;">Serie</td><td style="border-top: 1px solid black;">97.7</td></tr> <tr><td style="border-top: 1px solid black;">Total</td><td style="border-top: 1px solid black;">291.8</td></tr> </table>	26:	9.7	↖	27:	9.9	↑	28:	9.4	↗	29:	9.8	↑	30:	10.3	↗	31:	8.9	↑	32:	9.0	↑	33:	9.7	↑	34:	10.6	↗	35:	10.4	↘	Serie	97.7	Total	291.8
26:	9.7	↖																																		
27:	9.9	↑																																		
28:	9.4	↗																																		
29:	9.8	↑																																		
30:	10.3	↗																																		
31:	8.9	↑																																		
32:	9.0	↑																																		
33:	9.7	↑																																		
34:	10.6	↗																																		
35:	10.4	↘																																		
Serie	97.7																																			
Total	291.8																																			
<p>60 Skott</p>	<p>60 Skott</p>	<table style="width:100%; border-collapse: collapse;"> <tr><td>36:</td><td>10.1</td><td>↗</td></tr> <tr><td>37:</td><td>9.6</td><td>↖</td></tr> <tr><td>38:</td><td>8.9</td><td>↑</td></tr> <tr><td>39:</td><td>10.0</td><td>↖</td></tr> <tr><td>40:</td><td>10.3</td><td>↘</td></tr> <tr><td>41:</td><td>9.5</td><td>→</td></tr> <tr><td>42:</td><td>9.8</td><td>↑</td></tr> <tr><td>43:</td><td>9.7</td><td>↑</td></tr> <tr><td>44:</td><td>9.2</td><td>↗</td></tr> <tr><td>45:</td><td>9.9</td><td>↖</td></tr> </table> <table style="width:100%; border-collapse: collapse; margin-top: 5px;"> <tr><td style="border-top: 1px solid black;">Serie</td><td style="border-top: 1px solid black;">97.0</td></tr> <tr><td style="border-top: 1px solid black;">Total</td><td style="border-top: 1px solid black;">388.8</td></tr> </table>	36:	10.1	↗	37:	9.6	↖	38:	8.9	↑	39:	10.0	↖	40:	10.3	↘	41:	9.5	→	42:	9.8	↑	43:	9.7	↑	44:	9.2	↗	45:	9.9	↖	Serie	97.0	Total	388.8
36:	10.1	↗																																		
37:	9.6	↖																																		
38:	8.9	↑																																		
39:	10.0	↖																																		
40:	10.3	↘																																		
41:	9.5	→																																		
42:	9.8	↑																																		
43:	9.7	↑																																		
44:	9.2	↗																																		
45:	9.9	↖																																		
Serie	97.0																																			
Total	388.8																																			

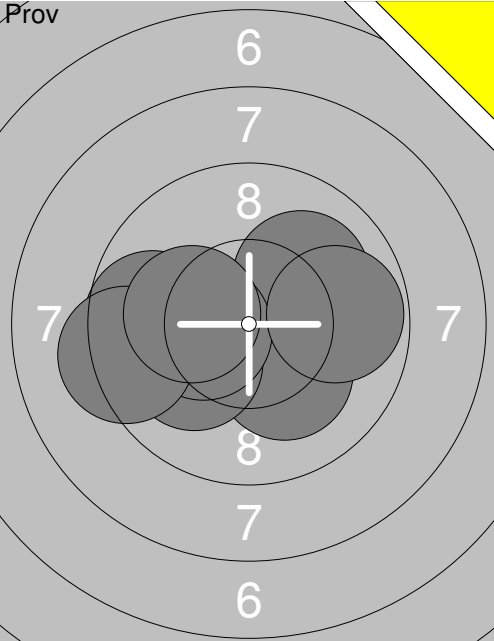
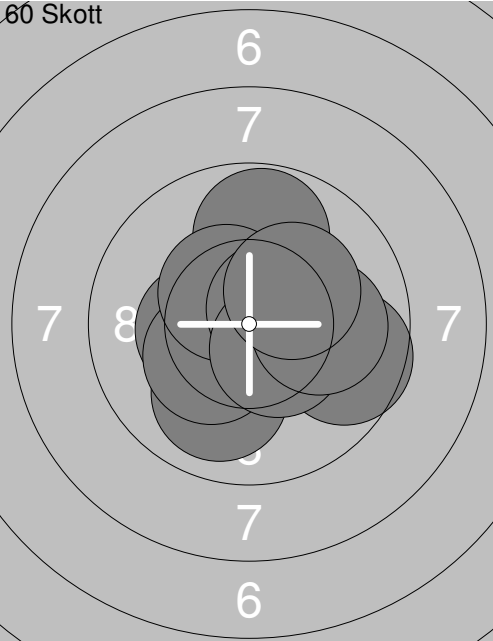
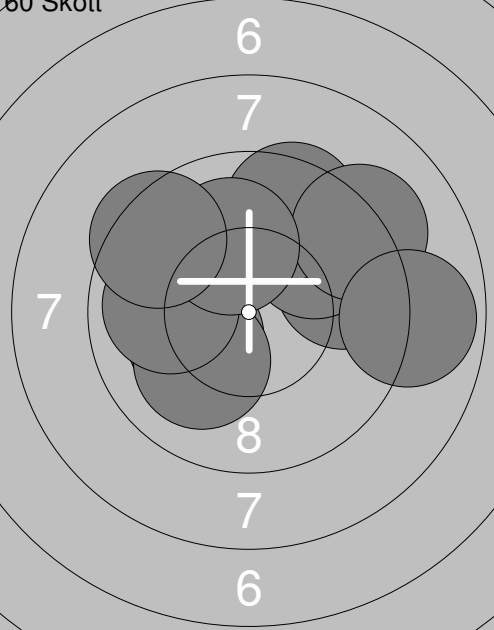
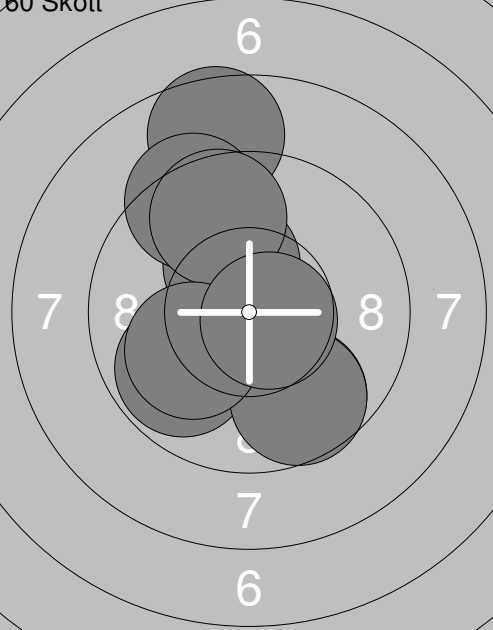
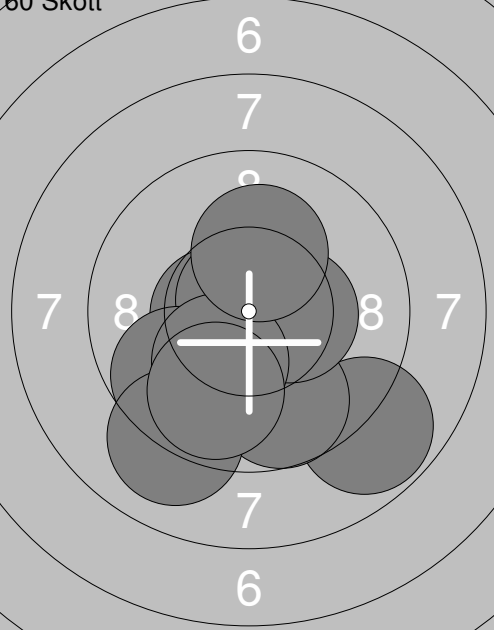

Skjutlag <b>2</b>	Tavla <b>30</b>	<b>Ellen Alenius</b>	
S		Ramselefors	
13.01.2019	Skyttiaden 2019	Umeå skytteallians	
Prov 	1: 10.1 ↗ 2: 10.2 ↘ 3: 10.1 ↙ 4: 10.4 ✕ 5: 9.7 ← 6: 9.3 ← 7: 10.2 ✕ 8: 9.8 → Serie 79.8 Total 0.0	60 Skott 	1: 9.8 ↑ 2: 10.3 ✕ 3: 10.0 ↓ 4: 10.3 ✕ 5: 10.5 ✕ 6: 9.6 → 7: 10.6 ✕ 8: 10.5 ✕ 9: 10.0 → 10: 10.2 ✕ Serie 101.8 Total 101.8
60 Skott 	11: 9.7 → 12: 9.8 ↗ 13: 10.2 ✕ 14: 10.1 ↙ 15: 9.9 ← 16: 9.5 ↑ 17: 9.2 ↗ 18: 8.9 → 19: 10.1 ↑ 20: 9.4 ↙ Serie 96.8 Total 198.6	60 Skott 	21: 9.7 ↓ 22: 9.8 ↙ 23: 10.5 ✕ 24: 10.3 ✕ 25: 8.6 ↑ 26: 9.3 ↑ 27: 9.7 ↓ 28: 9.6 ↑ 29: 10.1 ↙ 30: 10.7 ✕ Serie 98.3 Total 296.9
60 Skott 	31: 8.8 ↓ 32: 9.7 ↓ 33: 10.6 ✕ 34: 10.8 ✕ 35: 10.4 ✕ 36: 9.7 ↙ 37: 10.2 ✕ 38: 10.2 ✕ 39: 9.0 ↓ 40: 9.8 ↓ Serie 99.2 Total 396.1		

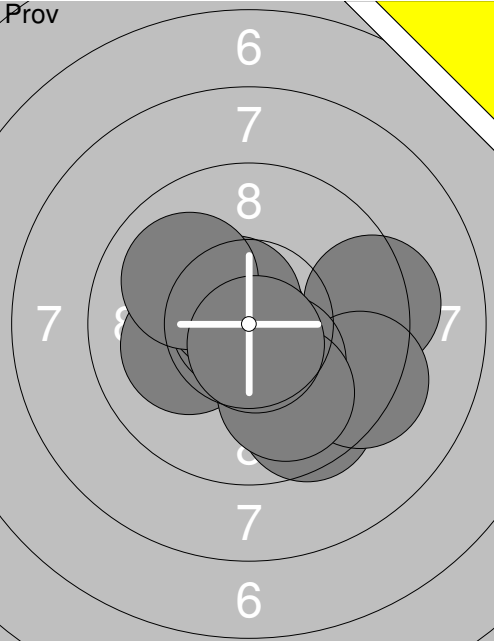
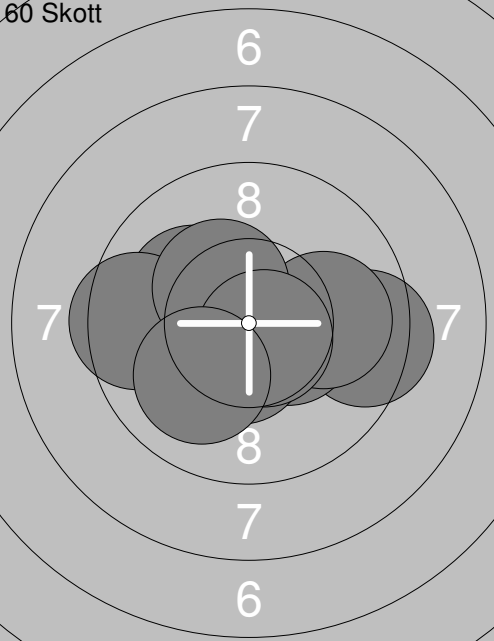
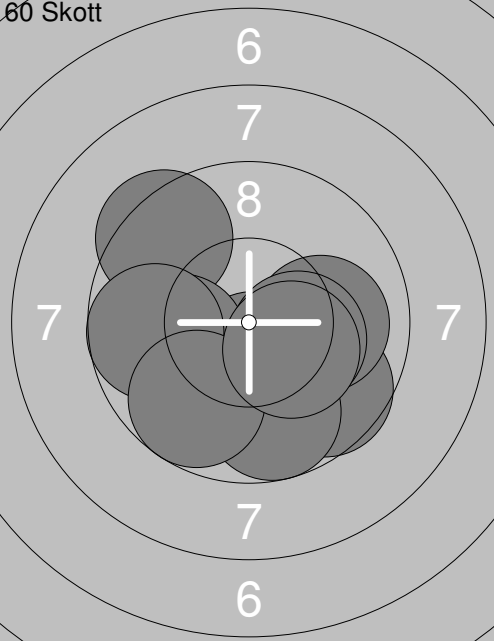
Skjuttlag	Tavla	Olivia Mikaelsson	
S	Ramselefors		
13.01.2019	Skyttiaden 2019	Umeå skytteallians	
Prov		1: 9.6 ↘ 2: 9.3 → 3: 9.3 ↘ 4: 10.3x↘ 5: 10.1 ← 6: 10.8x↗ 7: 9.9 ↘ 8: 10.6x↗ 9: 10.0 ↖ 10: 10.7x↘ Serie 100.6 Total 0.0	11: 10.3x↗ 12: 10.5x↖ 13: 10.1 ↓ 14: 10.5x↘ 15: 9.5 ↙ 16: 10.9x↘ 17: 10.6x↗ 18: 9.7 ↗ 19: 10.3x↘ 20: 10.7x↖ 21: 10.8x↖ Serie 103.6 Total 0.0
60 Skott		1: 9.4 → 2: 10.4x↘ 3: 10.1 ↖ 4: 10.9x↘ 5: 10.0 → 6: 9.5 ← 7: 10.5x↘ 8: 10.4x↗ 9: 10.7x↘ 10: 10.0 ↘ Serie 101.9 Total 101.9	11: 10.5x↖ 12: 10.1 ↓ 13: 10.5x↘ 14: 9.5 ↙ 15: 10.9x↘ 16: 10.6x↗ 17: 9.7 ↗ 18: 10.3x↘ 19: 10.7x↖ 20: 10.8x↖ Serie 103.6 Total 205.5
60 Skott		21: 9.6 ↘ 22: 10.4x↘ 23: 9.4 ↖ 24: 10.0 → 25: 10.0 ← 26: 10.3x↘ 27: 9.7 ← 28: 9.7 ↘ 29: 9.7 ↘ 30: 10.3x↘ Serie 99.1 Total 304.6	31: 9.9 → 32: 10.3x↘ 33: 10.0 ↗ 34: 9.5 ← 35: 10.4x↘ 36: 9.2 ← 37: 10.6x↗ 38: 9.4 ← 39: 10.2x↗ 40: 10.1 ↖ Serie 99.6 Total 404.2

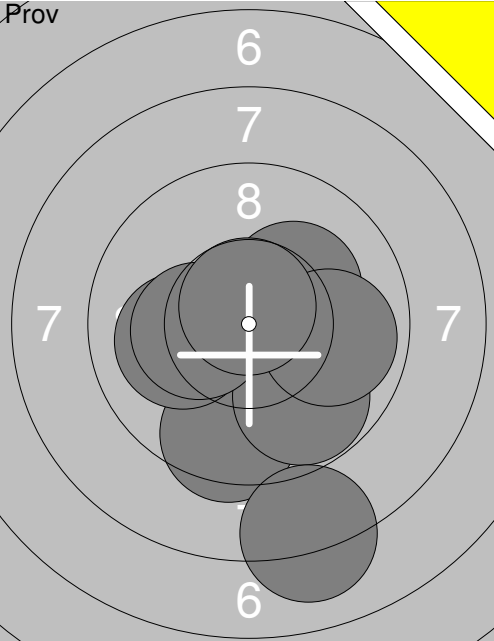
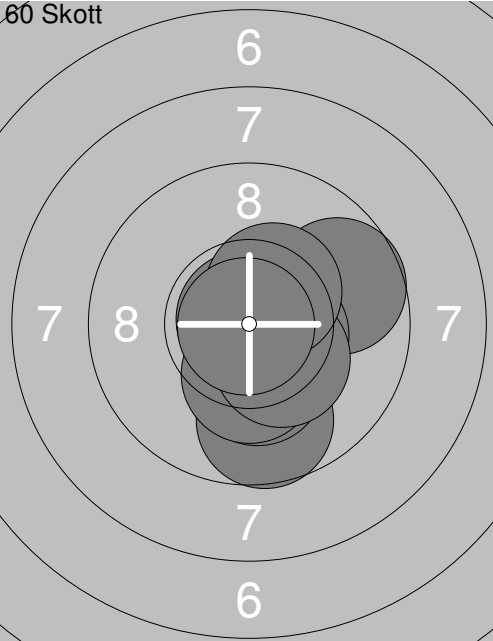
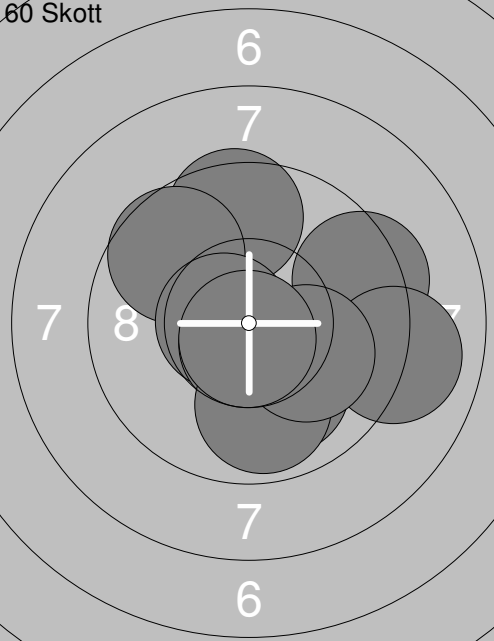
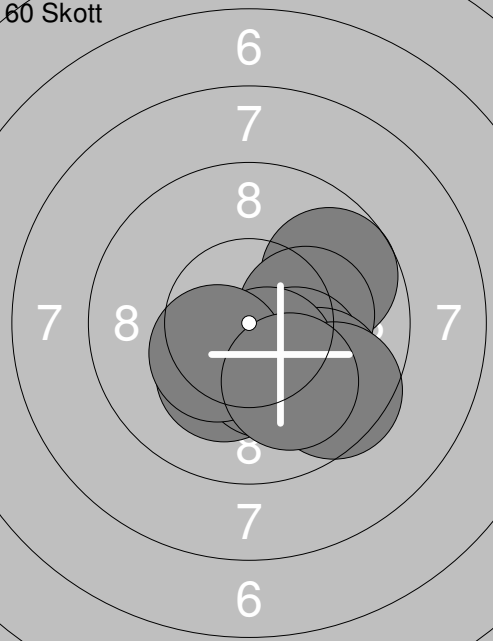
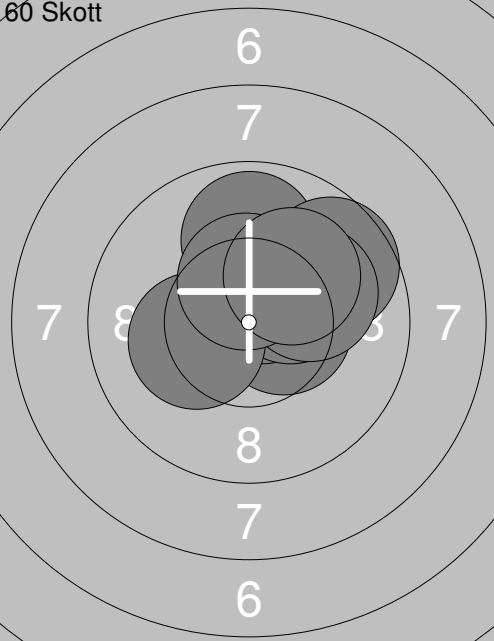
Skjutlag <b>2</b>	Tavla <b>34</b>	<b>Nisse Fredriksson</b>	
S		Umeå	
13.01.2019		Skyttiaden 2019	Umeå skytteallians
	1: 10.2x↓ 2: 9.5 ↓ 3: 10.1← 4: 9.8 ↓ 5: 10.2x↗ 6: 10.3x← 7: 9.9 → 8: 8.1 ↓ 9: 10.7x↑		1: 9.7 ↓ 2: 10.3x↓ 3: 10.6x→ 4: 9.7 → 5: 10.3x↓ 6: 10.5x→ 7: 10.9x↖ 8: 10.3x↓ 9: 10.4x↗ 10: 10.9x↖
	Serie 88.8		Serie 103.6
	Total 0.0		Total 103.6
	11: 9.4 → 12: 10.0 ↓ 13: 9.6 ↑ 14: 9.0 → 15: 9.7 ↖ 16: 10.6x← 17: 10.7x↓ 18: 9.9 ↓ 19: 10.1 → 20: 10.7x↓		21: 9.7 → 22: 10.2x→ 23: 10.2x↓ 24: 10.2x↓ 25: 9.8 ↓ 26: 10.3x↓ 27: 10.5x↓ 28: 9.5 ↓ 29: 10.4x↖ 30: 10.0 ↓
	Serie 99.7		Serie 100.8
	Total 203.3		Total 304.1
	31: 10.5x→ 32: 10.2x↗ 33: 9.9 ↑ 34: 10.6x↗ 35: 9.7 → 36: 10.3x↗ 37: 10.1 → 38: 10.2x← 39: 10.4x↑ 40: 10.1 ↗		
	Serie 102.0		
	Total 406.1		

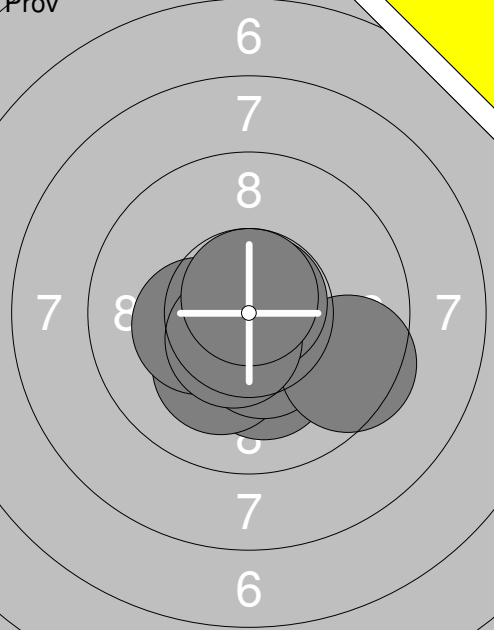
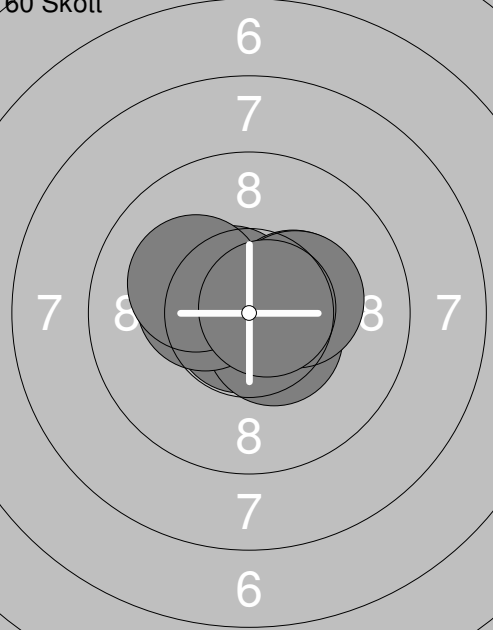
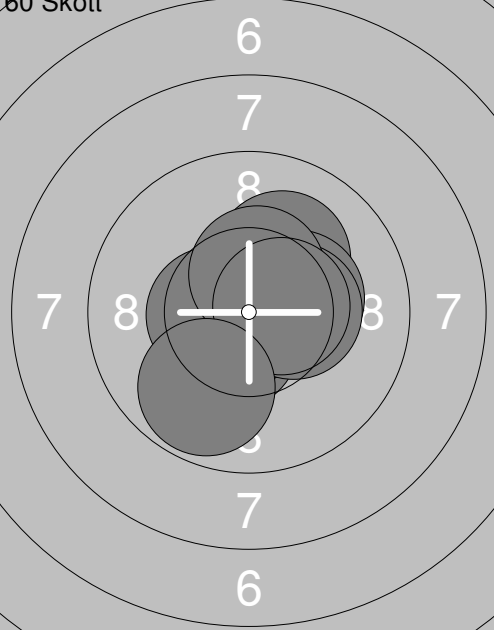
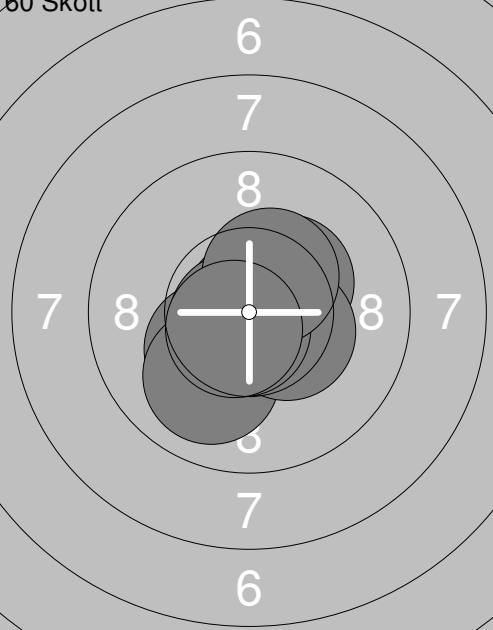
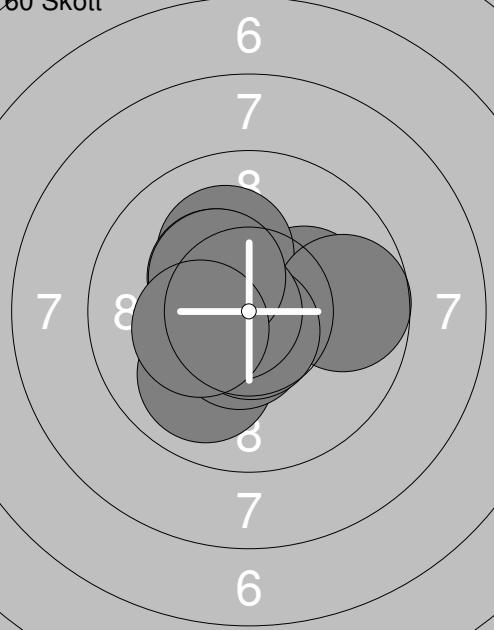
<p>Prov</p>  <p style="text-align: center;">6 7 8 7 6</p>	<p>1: 10.2x↘ 2: 10.2x↘ 3: 10.4x↘ 4: 10.6x↘ 5: 9.5 → 6: 10.8x↗ 7: 10.3x↖ 8: 10.5x↘ 9: 10.7x↑</p> <p>Serie 93.2 Total 0.0</p>	<p>60 Skott</p>  <p style="text-align: center;">6 7 8 7 6</p>	<p>1: 10.4x➤ 2: 10.5x➤ 3: 10.8x↘ 4: 10.6x↖ 5: 10.3x➤ 6: 10.5x↘ 7: 10.3x➤ 8: 10.4x↖ 9: 10.2x↖ 10: 10.7x➤</p> <p>Serie 104.7 Total 104.7</p>
<p>60 Skott</p>  <p style="text-align: center;">6 7 8 7 6</p>	<p>11: 10.3x➤ 12: 10.5x↘ 13: 10.9x↘ 14: 10.1 ↗ 15: 10.3x➤ 16: 10.4x➤ 17: 10.5x↖ 18: 10.4x↑ 19: 10.5x➤ 20: 9.8 ↓</p> <p>Serie 103.7 Total 208.4</p>	<p>60 Skott</p>  <p style="text-align: center;">6 7 8 7 6</p>	<p>21: 10.3x↖ 22: 10.0 ↓ 23: 10.8x↗ 24: 10.3x↗ 25: 10.7x↘ 26: 10.4x➤ 27: 10.8x↖ 28: 10.7x↘ 29: 10.4x↗ 30: 10.7x↘</p> <p>Serie 105.1 Total 313.5</p>
<p>60 Skott</p>  <p style="text-align: center;">6 7 8 7 6</p>	<p>31: 10.2x➤ 32: 10.0 ↓ 33: 10.6x↘ 34: 10.1 ↗ 35: 10.3x↖ 36: 9.7 → 37: 10.7x↘ 38: 10.8x↖ 39: 10.3x↖ 40: 10.3x↖</p> <p>Serie 103.0 Total 416.5</p>		

<p>Prov</p>	<p>1: 10.5x↖</p> <p>2: 10.5x↘</p> <p>3: 10.6x↖</p> <p>4: 10.3x↗</p> <p>5: 9.4 ↗</p> <p>6: 10.6x↗</p> <p>7: 8.9 ↗</p> <p>8: 9.9 ↗</p> <p>9: 10.8x←</p> <p>10: 9.8 ←</p> <hr/> <p>Serie 101.3</p> <hr/> <p>Total 0.0</p>	<p>Prov</p>	<p>11: 10.0←</p> <p>12: 10.2x↖</p> <p>13: 10.5x↓</p> <p>14: 10.4x↗</p> <p>15: 9.7 ↗</p> <p>16: 10.6x↓</p> <p>17: 10.3x→</p> <p>18: 9.0 ↖</p> <p>19: 10.6x↗</p> <p>20: 10.5x↓</p> <hr/> <p>Serie 101.8</p> <hr/> <p>Total 0.0</p>
<p>60 Skott</p>	<p>1: 10.2x↓</p> <p>2: 10.7x↖</p> <p>3: 10.0 ↖</p> <p>4: 9.7 ↗</p> <p>5: 9.6 ↓</p> <p>6: 10.4x↗</p> <p>7: 9.9 ↓</p> <p>8: 10.7x←</p> <p>9: 10.8x→</p> <p>10: 10.5x↗</p> <hr/> <p>Serie 102.5</p> <hr/> <p>Total 102.5</p>	<p>60 Skott</p>	<p>11: 9.7 →</p> <p>12: 10.0 ↘</p> <p>13: 9.3 ↗</p> <p>14: 10.3x↖</p> <p>15: 9.8 ←</p> <p>16: 9.8 ←</p> <p>17: 9.8 →</p> <p>18: 10.3x↖</p> <p>19: 10.7x↖</p> <p>20: 10.8x↖</p> <hr/> <p>Serie 100.5</p> <hr/> <p>Total 203.0</p>
<p>60 Skott</p>	<p>21: 10.8x↖</p> <p>22: 10.5x↖</p> <p>23: 8.6 →</p> <p>24: 10.0 ↗</p> <p>25: 10.0 ↓</p> <p>26: 10.8x↖</p> <p>27: 9.9 ↗</p> <p>28: 9.8 ↓</p> <p>29: 10.4x→</p> <p>30: 10.8x↖</p> <hr/> <p>Serie 101.6</p> <hr/> <p>Total 304.6</p>	<p>60 Skott</p>	<p>31: 9.8 →</p> <p>32: 9.7 ↘</p> <p>33: 9.9 ↓</p> <p>34: 9.2 ↘</p> <p>35: 10.3x↗</p> <p>36: 10.2x↗</p> <p>37: 10.2x↗</p> <p>38: 10.0 ↓</p> <p>39: 9.6 ↓</p> <p>40: 10.2x↗</p> <hr/> <p>Serie 99.1</p> <hr/> <p>Total 403.7</p>