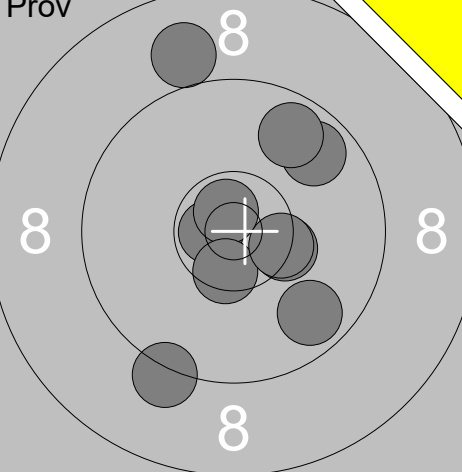
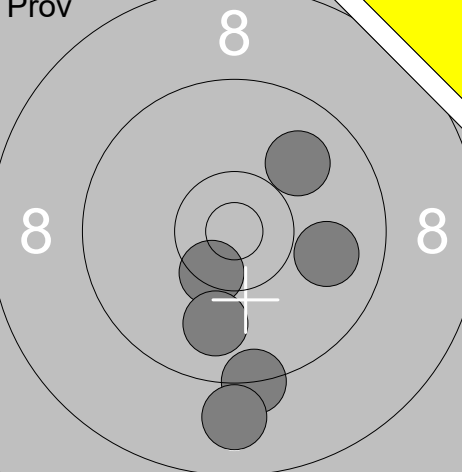
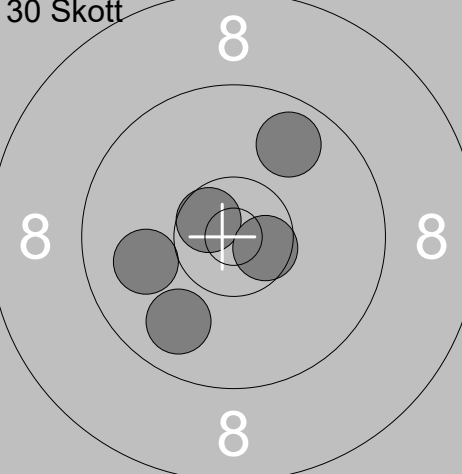
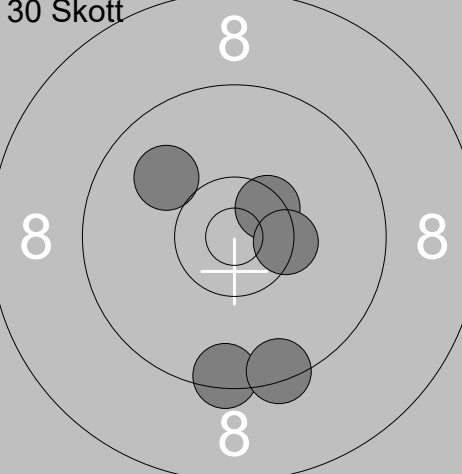
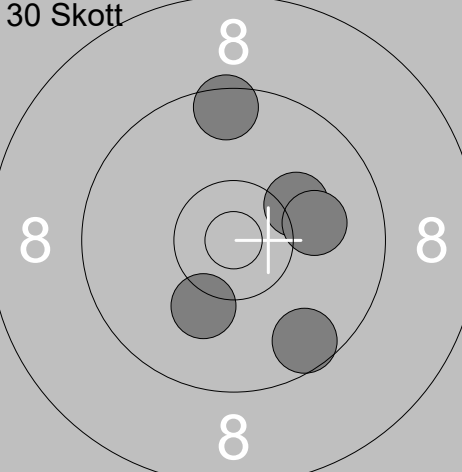
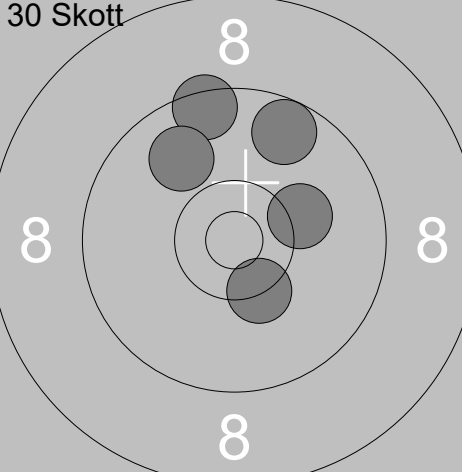
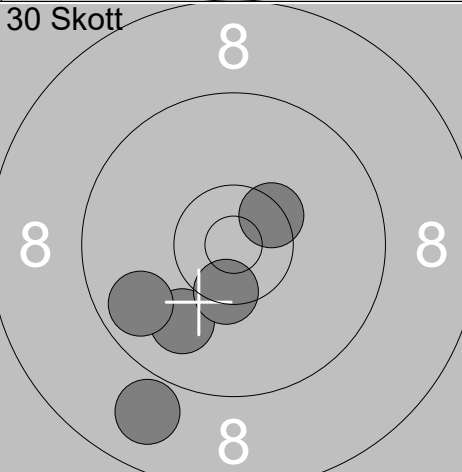
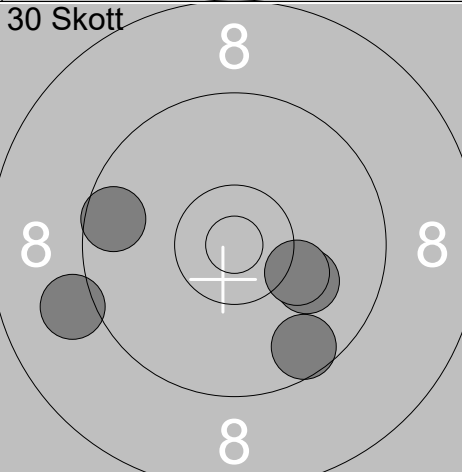
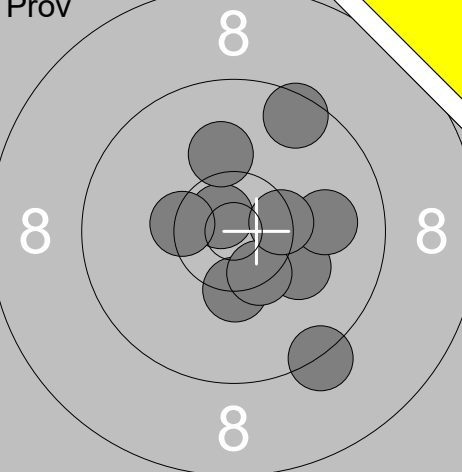
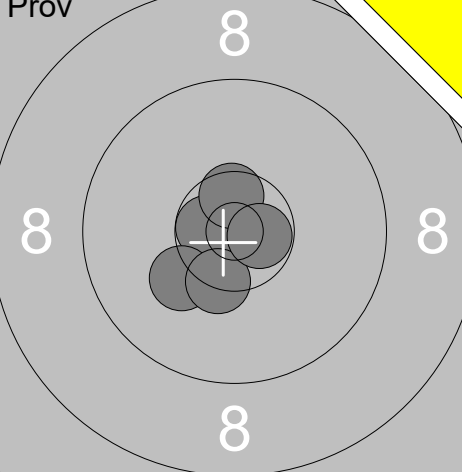
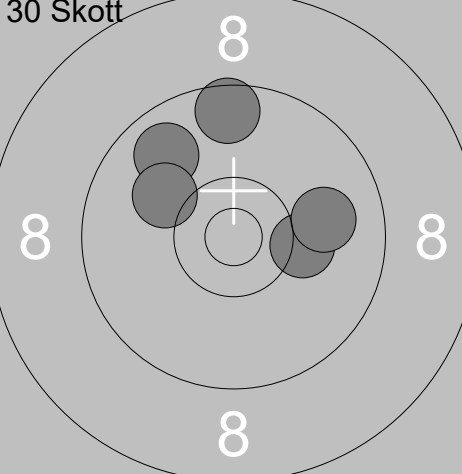
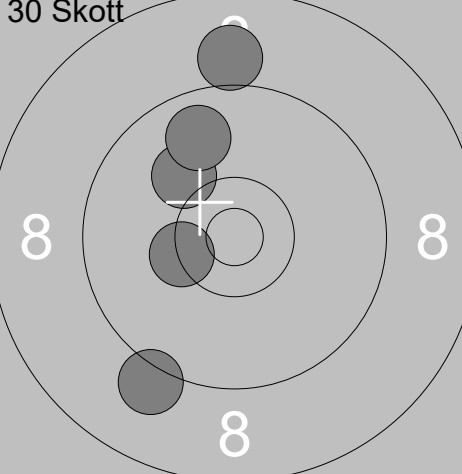
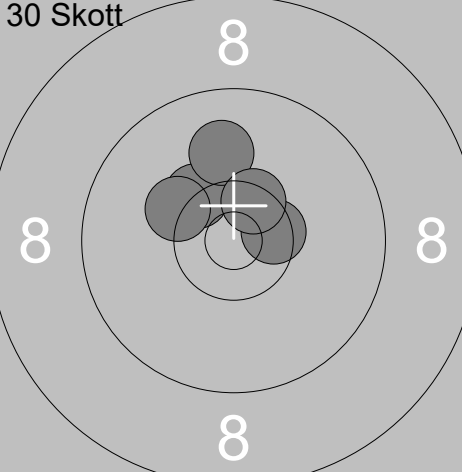
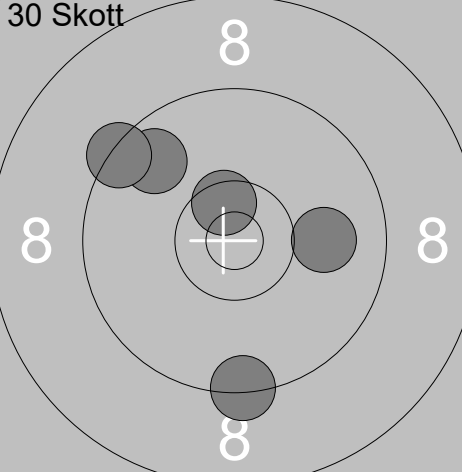
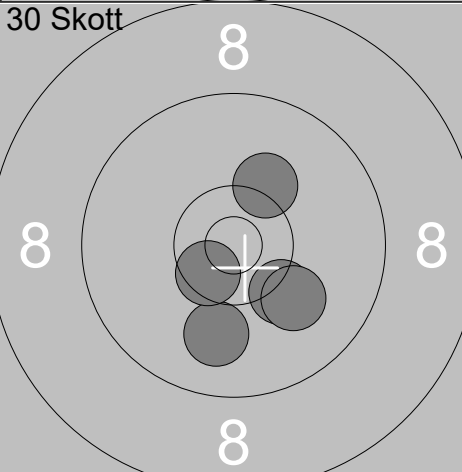
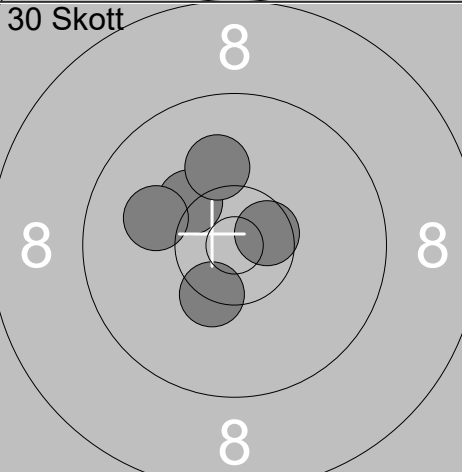
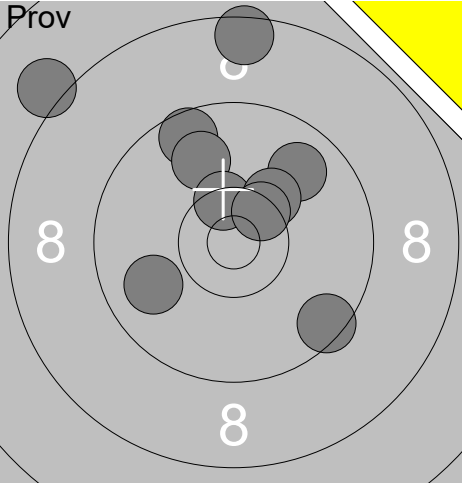
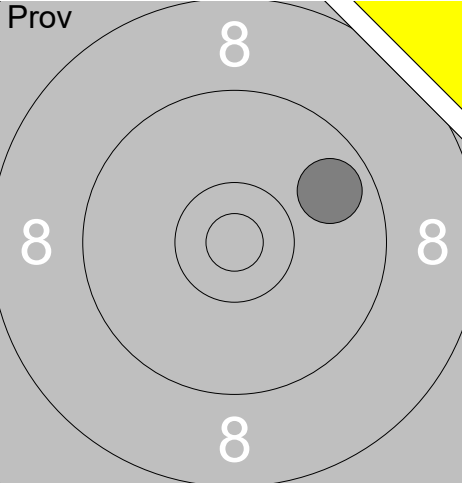
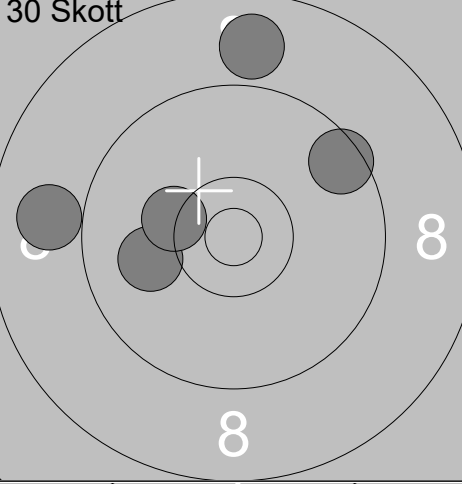
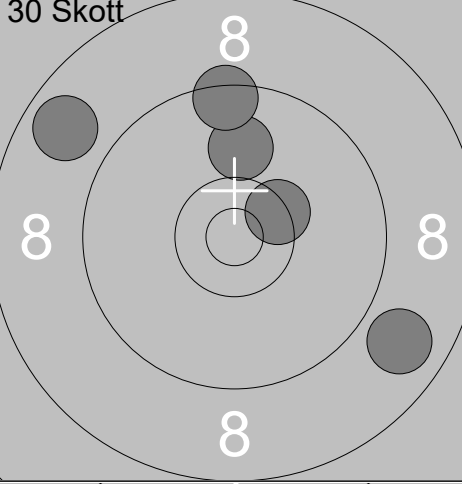
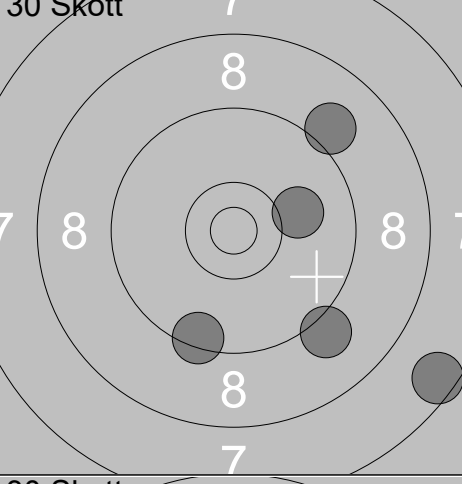
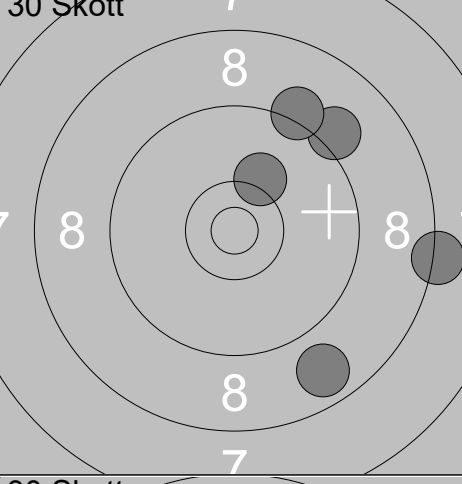
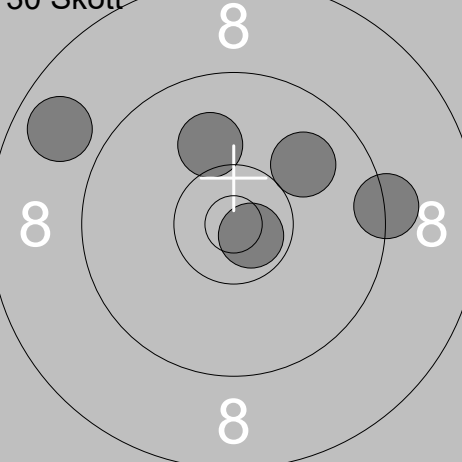
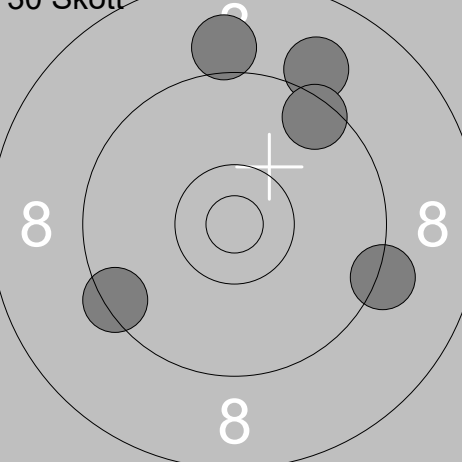
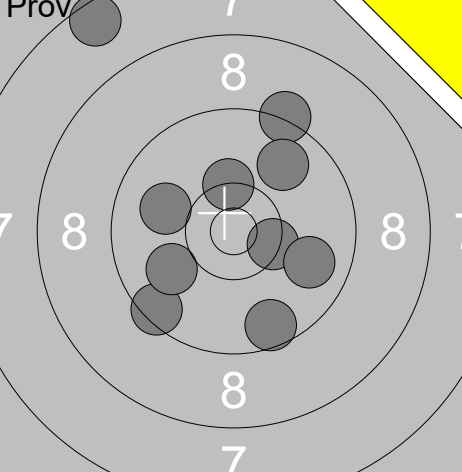
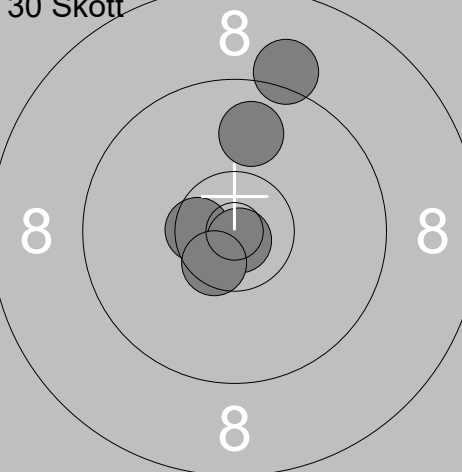
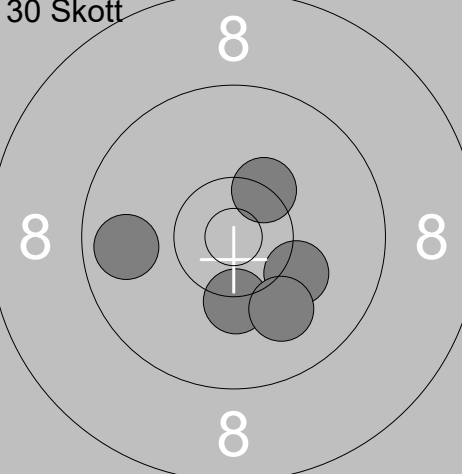
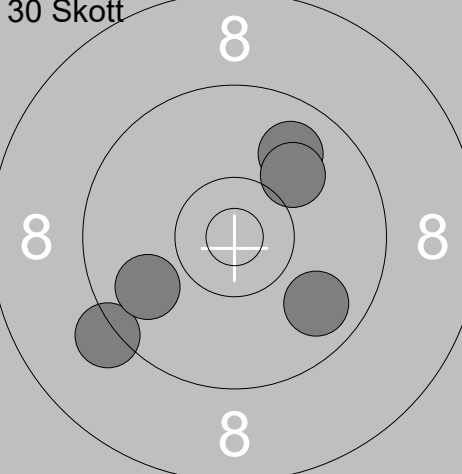
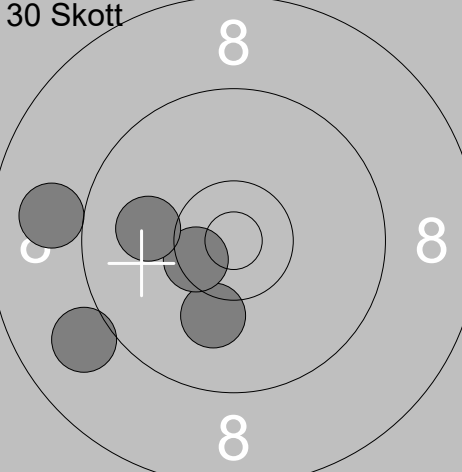
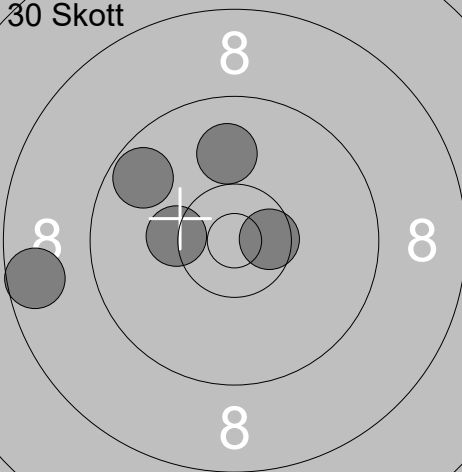
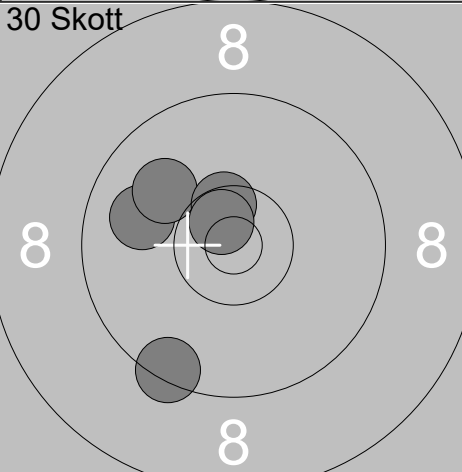

<p>Prov</p> 	<table style="width:100%; border-collapse: collapse;"> <tr><td>1:</td><td>9.0</td><td>↗</td></tr> <tr><td>2:</td><td>9.7</td><td>↘</td></tr> <tr><td>3:</td><td>10.4x</td><td>→</td></tr> <tr><td>4:</td><td>10.7x</td><td>←</td></tr> <tr><td>5:</td><td>10.7x</td><td>↗</td></tr> <tr><td>6:</td><td>9.2</td><td>↘</td></tr> <tr><td>7:</td><td>10.5x</td><td>↘</td></tr> <tr><td>8:</td><td>10.4x</td><td>→</td></tr> <tr><td>9:</td><td>9.7</td><td>↗</td></tr> <tr><td>10:</td><td>9.7</td><td>↗</td></tr> <tr><td colspan="2">Serie</td><td style="text-align: right;">95</td></tr> <tr><td colspan="2">Total</td><td style="text-align: right;">0</td></tr> </table>	1:	9.0	↗	2:	9.7	↘	3:	10.4x	→	4:	10.7x	←	5:	10.7x	↗	6:	9.2	↘	7:	10.5x	↘	8:	10.4x	→	9:	9.7	↗	10:	9.7	↗	Serie		95	Total		0	<p>Prov</p>  <table style="width:100%; border-collapse: collapse;"> <tr><td>11:</td><td>10.4x</td><td>↘</td></tr> <tr><td>12:</td><td>9.9</td><td>↗</td></tr> <tr><td>13:</td><td>9.9</td><td>↘</td></tr> <tr><td>14:</td><td>9.9</td><td>→</td></tr> <tr><td>15:</td><td>9.3</td><td>↘</td></tr> <tr><td>16:</td><td>8.9</td><td>↘</td></tr> <tr><td colspan="2">Serie</td><td style="text-align: right;">54</td></tr> <tr><td colspan="2">Total</td><td style="text-align: right;">0</td></tr> </table>	11:	10.4x	↘	12:	9.9	↗	13:	9.9	↘	14:	9.9	→	15:	9.3	↘	16:	8.9	↘	Serie		54	Total		0
1:	9.0	↗																																																												
2:	9.7	↘																																																												
3:	10.4x	→																																																												
4:	10.7x	←																																																												
5:	10.7x	↗																																																												
6:	9.2	↘																																																												
7:	10.5x	↘																																																												
8:	10.4x	→																																																												
9:	9.7	↗																																																												
10:	9.7	↗																																																												
Serie		95																																																												
Total		0																																																												
11:	10.4x	↘																																																												
12:	9.9	↗																																																												
13:	9.9	↘																																																												
14:	9.9	→																																																												
15:	9.3	↘																																																												
16:	8.9	↘																																																												
Serie		54																																																												
Total		0																																																												
<p>30 Skott</p> 	<table style="width:100%; border-collapse: collapse;"> <tr><td>1:</td><td>10.6x</td><td>↗</td></tr> <tr><td>2:</td><td>10.0</td><td>←</td></tr> <tr><td>3:</td><td>9.8</td><td>↗</td></tr> <tr><td>4:</td><td>10.6x</td><td>→</td></tr> <tr><td>5:</td><td>9.8</td><td>↘</td></tr> <tr><td colspan="2">Serie</td><td style="text-align: right;">48</td></tr> <tr><td colspan="2">Total</td><td style="text-align: right;">48</td></tr> </table>	1:	10.6x	↗	2:	10.0	←	3:	9.8	↗	4:	10.6x	→	5:	9.8	↘	Serie		48	Total		48	<p>30 Skott</p>  <table style="width:100%; border-collapse: collapse;"> <tr><td>6:</td><td>10.5x</td><td>↗</td></tr> <tr><td>7:</td><td>9.4</td><td>↘</td></tr> <tr><td>8:</td><td>10.4x</td><td>→</td></tr> <tr><td>9:</td><td>10.0</td><td>↗</td></tr> <tr><td>10:</td><td>9.4</td><td>↘</td></tr> <tr><td colspan="2">Serie</td><td style="text-align: right;">48</td></tr> <tr><td colspan="2">Total</td><td style="text-align: right;">96</td></tr> </table>	6:	10.5x	↗	7:	9.4	↘	8:	10.4x	→	9:	10.0	↗	10:	9.4	↘	Serie		48	Total		96																		
1:	10.6x	↗																																																												
2:	10.0	←																																																												
3:	9.8	↗																																																												
4:	10.6x	→																																																												
5:	9.8	↘																																																												
Serie		48																																																												
Total		48																																																												
6:	10.5x	↗																																																												
7:	9.4	↘																																																												
8:	10.4x	→																																																												
9:	10.0	↗																																																												
10:	9.4	↘																																																												
Serie		48																																																												
Total		96																																																												
<p>30 Skott</p> 	<table style="width:100%; border-collapse: collapse;"> <tr><td>11:</td><td>10.2</td><td>↗</td></tr> <tr><td>12:</td><td>9.5</td><td>↑</td></tr> <tr><td>13:</td><td>10.1</td><td>→</td></tr> <tr><td>14:</td><td>9.6</td><td>↘</td></tr> <tr><td>15:</td><td>10.2</td><td>↘</td></tr> <tr><td colspan="2">Serie</td><td style="text-align: right;">48</td></tr> <tr><td colspan="2">Total</td><td style="text-align: right;">144</td></tr> </table>	11:	10.2	↗	12:	9.5	↑	13:	10.1	→	14:	9.6	↘	15:	10.2	↘	Serie		48	Total		144	<p>30 Skott</p>  <table style="width:100%; border-collapse: collapse;"> <tr><td>16:</td><td>9.5</td><td>↗</td></tr> <tr><td>17:</td><td>10.3x</td><td>↘</td></tr> <tr><td>18:</td><td>9.9</td><td>↗</td></tr> <tr><td>19:</td><td>10.2</td><td>→</td></tr> <tr><td>20:</td><td>9.7</td><td>↗</td></tr> <tr><td colspan="2">Serie</td><td style="text-align: right;">47</td></tr> <tr><td colspan="2">Total</td><td style="text-align: right;">191</td></tr> </table>	16:	9.5	↗	17:	10.3x	↘	18:	9.9	↗	19:	10.2	→	20:	9.7	↗	Serie		47	Total		191																		
11:	10.2	↗																																																												
12:	9.5	↑																																																												
13:	10.1	→																																																												
14:	9.6	↘																																																												
15:	10.2	↘																																																												
Serie		48																																																												
Total		144																																																												
16:	9.5	↗																																																												
17:	10.3x	↘																																																												
18:	9.9	↗																																																												
19:	10.2	→																																																												
20:	9.7	↗																																																												
Serie		47																																																												
Total		191																																																												
<p>30 Skott</p> 	<table style="width:100%; border-collapse: collapse;"> <tr><td>21:</td><td>9.9</td><td>↘</td></tr> <tr><td>22:</td><td>9.8</td><td>←</td></tr> <tr><td>23:</td><td>10.4x</td><td>↘</td></tr> <tr><td>24:</td><td>10.4x</td><td>↗</td></tr> <tr><td>25:</td><td>8.9</td><td>↘</td></tr> <tr><td colspan="2">Serie</td><td style="text-align: right;">46</td></tr> <tr><td colspan="2">Total</td><td style="text-align: right;">237</td></tr> </table>	21:	9.9	↘	22:	9.8	←	23:	10.4x	↘	24:	10.4x	↗	25:	8.9	↘	Serie		46	Total		237	<p>30 Skott</p>  <table style="width:100%; border-collapse: collapse;"> <tr><td>26:</td><td>9.6</td><td>↘</td></tr> <tr><td>27:</td><td>10.1</td><td>↘</td></tr> <tr><td>28:</td><td>10.2</td><td>→</td></tr> <tr><td>29:</td><td>9.6</td><td>←</td></tr> <tr><td>30:</td><td>9.1</td><td>←</td></tr> <tr><td colspan="2">Serie</td><td style="text-align: right;">47</td></tr> <tr><td colspan="2">Total</td><td style="text-align: right;">284</td></tr> </table>	26:	9.6	↘	27:	10.1	↘	28:	10.2	→	29:	9.6	←	30:	9.1	←	Serie		47	Total		284																		
21:	9.9	↘																																																												
22:	9.8	←																																																												
23:	10.4x	↘																																																												
24:	10.4x	↗																																																												
25:	8.9	↘																																																												
Serie		46																																																												
Total		237																																																												
26:	9.6	↘																																																												
27:	10.1	↘																																																												
28:	10.2	→																																																												
29:	9.6	←																																																												
30:	9.1	←																																																												
Serie		47																																																												
Total		284																																																												

<p>Prov</p>	<p>1: 10.5x ↘ 2: 8.2 ↓ 3: 9.3 ← 4: 8.7 ↗ 5: 10.0 ↗ 6: 9.4 → 7: 9.8 ↘ 8: 10.5x ↗ 9: 7.9 ↓ 10: 8.6 →</p> <p>Serie 88 Total 0</p>	<p>Prov</p>	<p>11: 10.4x ← 12: 7.9 → 13: 9.6 ↓</p> <p>Serie 26 Total 0</p>
<p>30 Skott</p>	<p>1: 10.2 ← 2: 9.1 ↓ 3: 9.3 ↓ 4: 9.3 → 5: 10.2 →</p> <p>Serie 47 Total 47</p>	<p>30 Skott</p>	<p>6: 10.0 → 7: 9.6 → 8: 8.1 ← 9: 9.7 ↓ 10: 8.3 →</p> <p>Serie 44 Total 91</p>
<p>30 Skott</p>	<p>11: 9.4 ↗ 12: 7.4 → 13: 9.7 ↗ 14: 8.3 → 15: 7.8 ↘</p> <p>Serie 40 Total 131</p>	<p>30 Skott</p>	<p>16: 9.0 ↓ 17: 5.7 ↓ 18: 7.9 ↓ 19: 9.9 ↗ 20: 7.0 ↑</p> <p>Serie 37 Total 168</p>
<p>30 Skott</p>	<p>21: 7.9 ↓ 22: 9.0 ← 23: 7.1 ↓ 24: 10.2 ↓ 25: 10.3 →</p> <p>Serie 43 Total 211</p>	<p>30 Skott</p>	<p>26: 10.0 ↗ 27: 8.9 ↓ 28: 9.1 → 29: 8.8 → 30: 8.5 ↑</p> <p>Serie 43 Total 254</p>

Prov 	1: 9.5 ↗ 2: 10.1 ↘ 3: 9.3 ↘ 4: 10.3x ↘ 5: 10.0 → 6: 10.4x ↘ 7: 10.7x ↗ 8: 10.4x → 9: 10.1 ↗ 10: 10.4x ← <hr/> Serie 98 Total 0	Prov 	11: 10.7x ← 12: 10.2 ↘ 13: 10.4x ↘ 14: 10.6x ↑ 15: 10.7x → <hr/> Serie 50 Total 0
30 Skott 	1: 10.2 → 2: 10.0 → 3: 9.6 ↑ 4: 9.8 ↗ 5: 10.1 ↗ <hr/> Serie 48 Total 48	30 Skott 	6: 9.1 ↘ 7: 10.1 ↗ 8: 9.0 ↑ 9: 9.8 ↗ 10: 10.3x ← <hr/> Serie 47 Total 95
30 Skott 	11: 10.5x → 12: 10.3x ↗ 13: 10.3 ↗ 14: 10.0 ↑ 15: 10.5x ↗ <hr/> Serie 50 Total 145	30 Skott 	16: 9.7 ↗ 17: 10.0 → 18: 10.5x ↗ 19: 9.3 ↘ 20: 9.4 ↗ <hr/> Serie 47 Total 192
30 Skott 	21: 10.0 ↘ 22: 10.2 ↗ 23: 10.5x ↘ 24: 10.2 ↘ 25: 10.1 ↘ <hr/> Serie 50 Total 242	30 Skott 	26: 10.3 ↗ 27: 10.0 ← 28: 10.4x ↘ 29: 10.6x → 30: 10.1 ↑ <hr/> Serie 50 Total 292

Skjuttag	Tavla	Dan-Ivan Karlsson	
1	5	Ramselefors	Vb
28.04.2019	Vindelnskottet 2019	Ramselefors SKF	
Prov 	1: 8.1 ↖ 2: 9.9 ↙ 3: 9.6 ↗ 4: 9.8 ↗ 5: 9.9 ↗ 6: 10.4x ↗ 7: 8.5 ↗ 8: 10.3 ↗ 9: 10.5x ↗ 10: 9.5 ↘ Serie 91 Total 0	Prov 	11: 9.8 ↗ Serie 9 Total 0
30 Skott 	1: 8.9 ← 2: 10.0 ← 3: 10.3 ← 4: 8.9 ↑ 5: 9.5 ↗ Serie 45 Total 45	30 Skott 	6: 10.0 ↑ 7: 9.4 ↑ 8: 10.4x ↗ 9: 8.8 ↖ 10: 8.8 ↘ Serie 45 Total 90
30 Skott 	11: 7.5 ↘ 12: 9.1 ↘ 13: 9.4 ↘ 14: 9.1 ↗ 15: 10.0 → Serie 44 Total 134	30 Skott 	16: 10.2 ↗ 17: 8.2 → 18: 8.8 ↘ 19: 9.1 ↗ 20: 9.2 ↗ Serie 44 Total 178
30 Skott 	21: 9.3 → 22: 10.0 ↗ 23: 10.1 ↗ 24: 8.8 ↖ 25: 10.7x ↘ Serie 47 Total 225	30 Skott 	26: 9.2 ↘ 27: 9.4 ↙ 28: 9.0 ↗ 29: 9.5 ↗ 30: 9.0 ↑ Serie 45 Total 270

 <p>Prov</p>	<table border="1" style="width:100%; border-collapse: collapse;"> <tr><td>1:</td><td>7.5</td><td>↖</td></tr> <tr><td>2:</td><td>9.3</td><td>↗</td></tr> <tr><td>3:</td><td>9.8</td><td>↗</td></tr> <tr><td>4:</td><td>10.4x</td><td>→</td></tr> <tr><td>5:</td><td>9.8</td><td>→</td></tr> <tr><td>6:</td><td>9.5</td><td>↘</td></tr> <tr><td>7:</td><td>9.6</td><td>↘</td></tr> <tr><td>8:</td><td>10.0</td><td>↖</td></tr> <tr><td>9:</td><td>10.0</td><td>↖</td></tr> <tr><td>10:</td><td>10.3x</td><td>↗</td></tr> <tr><td colspan="2">Serie</td><td>92</td></tr> <tr><td colspan="2">Total</td><td>0</td></tr> </table>	1:	7.5	↖	2:	9.3	↗	3:	9.8	↗	4:	10.4x	→	5:	9.8	→	6:	9.5	↘	7:	9.6	↘	8:	10.0	↖	9:	10.0	↖	10:	10.3x	↗	Serie		92	Total		0	 <p>30 Skott</p> <table border="1" style="width:100%; border-collapse: collapse;"> <tr><td>1:</td><td>10.5x</td><td>←</td></tr> <tr><td>2:</td><td>9.9</td><td>↗</td></tr> <tr><td>3:</td><td>10.8x</td><td>↘</td></tr> <tr><td>4:</td><td>9.1</td><td>↗</td></tr> <tr><td>5:</td><td>10.5x</td><td>↘</td></tr> <tr><td colspan="2">Serie</td><td>48</td></tr> <tr><td colspan="2">Total</td><td>48</td></tr> </table>	1:	10.5x	←	2:	9.9	↗	3:	10.8x	↘	4:	9.1	↗	5:	10.5x	↘	Serie		48	Total		48
1:	7.5	↖																																																									
2:	9.3	↗																																																									
3:	9.8	↗																																																									
4:	10.4x	→																																																									
5:	9.8	→																																																									
6:	9.5	↘																																																									
7:	9.6	↘																																																									
8:	10.0	↖																																																									
9:	10.0	↖																																																									
10:	10.3x	↗																																																									
Serie		92																																																									
Total		0																																																									
1:	10.5x	←																																																									
2:	9.9	↗																																																									
3:	10.8x	↘																																																									
4:	9.1	↗																																																									
5:	10.5x	↘																																																									
Serie		48																																																									
Total		48																																																									
 <p>30 Skott</p>	<table border="1" style="width:100%; border-collapse: collapse;"> <tr><td>6:</td><td>9.8</td><td>←</td></tr> <tr><td>7:</td><td>10.3x</td><td>↗</td></tr> <tr><td>8:</td><td>10.3</td><td>↘</td></tr> <tr><td>9:</td><td>10.2</td><td>↘</td></tr> <tr><td>10:</td><td>10.0</td><td>↘</td></tr> <tr><td colspan="2">Serie</td><td>49</td></tr> <tr><td colspan="2">Total</td><td>97</td></tr> </table>	6:	9.8	←	7:	10.3x	↗	8:	10.3	↘	9:	10.2	↘	10:	10.0	↘	Serie		49	Total		97	 <p>30 Skott</p> <table border="1" style="width:100%; border-collapse: collapse;"> <tr><td>11:</td><td>9.9</td><td>↗</td></tr> <tr><td>12:</td><td>9.2</td><td>↖</td></tr> <tr><td>13:</td><td>10.0</td><td>↗</td></tr> <tr><td>14:</td><td>9.8</td><td>↘</td></tr> <tr><td>15:</td><td>9.9</td><td>↖</td></tr> <tr><td colspan="2">Serie</td><td>46</td></tr> <tr><td colspan="2">Total</td><td>143</td></tr> </table>	11:	9.9	↗	12:	9.2	↖	13:	10.0	↗	14:	9.8	↘	15:	9.9	↖	Serie		46	Total		143															
6:	9.8	←																																																									
7:	10.3x	↗																																																									
8:	10.3	↘																																																									
9:	10.2	↘																																																									
10:	10.0	↘																																																									
Serie		49																																																									
Total		97																																																									
11:	9.9	↗																																																									
12:	9.2	↖																																																									
13:	10.0	↗																																																									
14:	9.8	↘																																																									
15:	9.9	↖																																																									
Serie		46																																																									
Total		143																																																									
 <p>30 Skott</p>	<table border="1" style="width:100%; border-collapse: collapse;"> <tr><td>16:</td><td>10.1</td><td>↘</td></tr> <tr><td>17:</td><td>10.5x</td><td>←</td></tr> <tr><td>18:</td><td>9.0</td><td>←</td></tr> <tr><td>19:</td><td>10.0</td><td>←</td></tr> <tr><td>20:</td><td>9.0</td><td>↖</td></tr> <tr><td colspan="2">Serie</td><td>48</td></tr> <tr><td colspan="2">Total</td><td>191</td></tr> </table>	16:	10.1	↘	17:	10.5x	←	18:	9.0	←	19:	10.0	←	20:	9.0	↖	Serie		48	Total		191	 <p>30 Skott</p> <table border="1" style="width:100%; border-collapse: collapse;"> <tr><td>21:</td><td>9.7</td><td>↖</td></tr> <tr><td>22:</td><td>8.6</td><td>←</td></tr> <tr><td>23:</td><td>10.6x</td><td>→</td></tr> <tr><td>24:</td><td>10.3</td><td>←</td></tr> <tr><td>25:</td><td>10.0</td><td>↗</td></tr> <tr><td colspan="2">Serie</td><td>47</td></tr> <tr><td colspan="2">Total</td><td>238</td></tr> </table>	21:	9.7	↖	22:	8.6	←	23:	10.6x	→	24:	10.3	←	25:	10.0	↗	Serie		47	Total		238															
16:	10.1	↘																																																									
17:	10.5x	←																																																									
18:	9.0	←																																																									
19:	10.0	←																																																									
20:	9.0	↖																																																									
Serie		48																																																									
Total		191																																																									
21:	9.7	↖																																																									
22:	8.6	←																																																									
23:	10.6x	→																																																									
24:	10.3	←																																																									
25:	10.0	↗																																																									
Serie		47																																																									
Total		238																																																									
 <p>30 Skott</p>	<table border="1" style="width:100%; border-collapse: collapse;"> <tr><td>26:</td><td>9.9</td><td>↖</td></tr> <tr><td>27:</td><td>9.4</td><td>↘</td></tr> <tr><td>28:</td><td>10.0</td><td>↗</td></tr> <tr><td>29:</td><td>10.5x</td><td>↗</td></tr> <tr><td>30:</td><td>10.7x</td><td>↗</td></tr> <tr><td colspan="2">Serie</td><td>48</td></tr> <tr><td colspan="2">Total</td><td>286</td></tr> </table>	26:	9.9	↖	27:	9.4	↘	28:	10.0	↗	29:	10.5x	↗	30:	10.7x	↗	Serie		48	Total		286																																					
26:	9.9	↖																																																									
27:	9.4	↘																																																									
28:	10.0	↗																																																									
29:	10.5x	↗																																																									
30:	10.7x	↗																																																									
Serie		48																																																									
Total		286																																																									

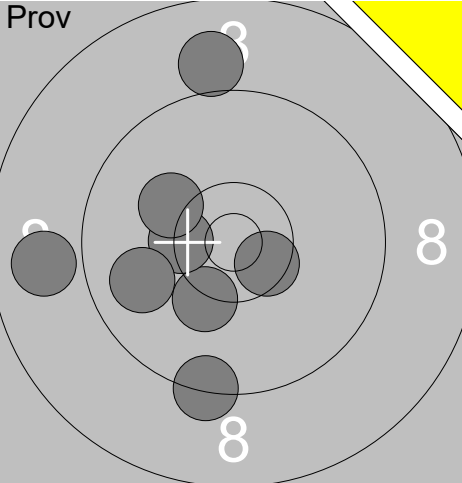
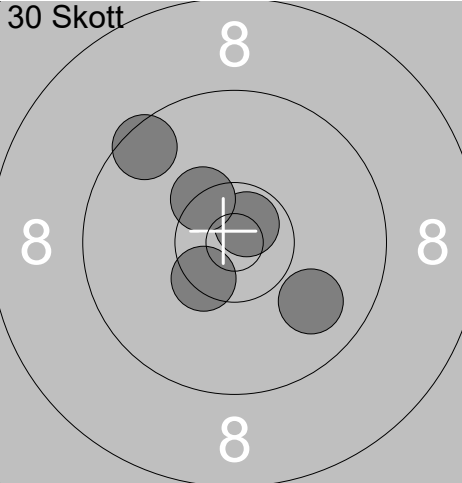
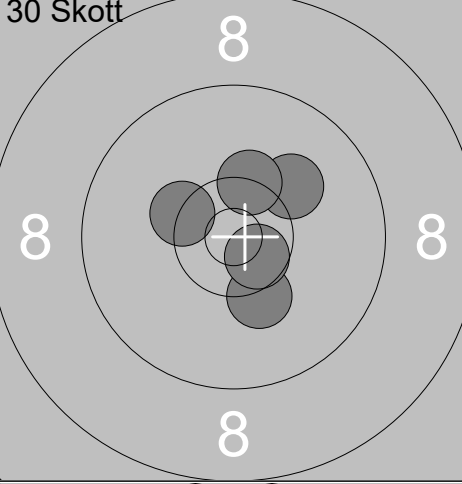
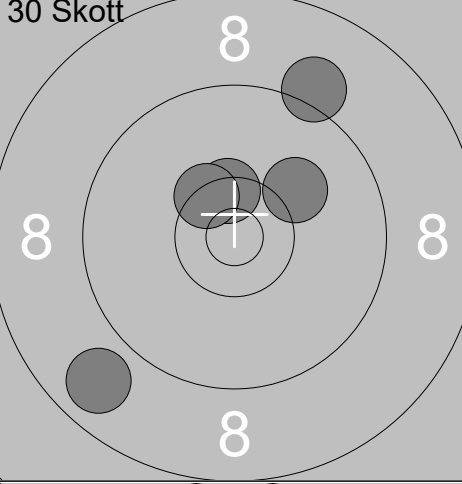
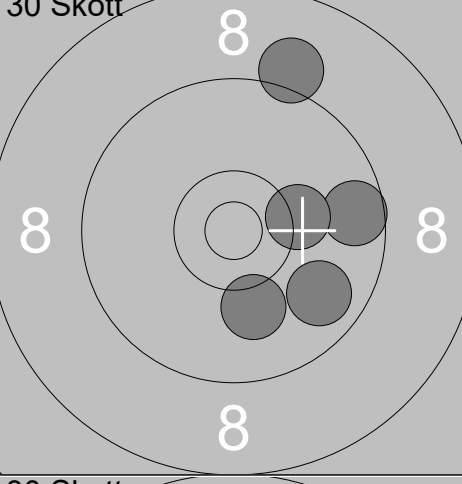
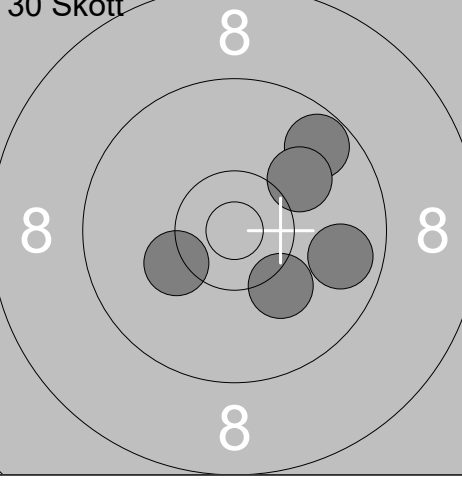
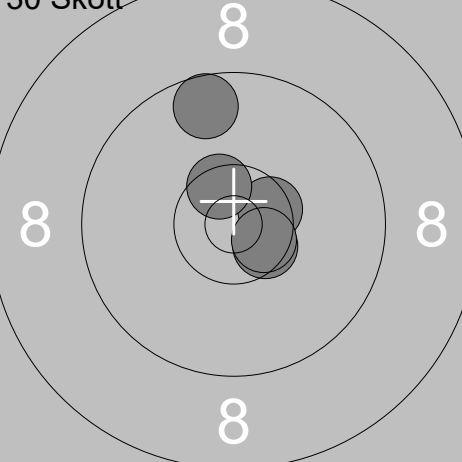
Skjuttag 1	Tavla 8	Jennifer Gustafsson	
Ramselefors		Ramselefors	Vb
28.04.2019	Vindelnskottet 2019	Ramselefors SKF	
Prov 	1: 10.3 ↘ 2: 9.0 ↗ 3: 10.4x ← 4: 8.9 ← 5: 10.2 ↗ 6: 9.3 ↘ 7: 10.5x ↘ 8: 9.9 ←	30 Skott 	1: 9.5 ↗ 2: 9.9 ↘ 3: 10.7x ↗ 4: 10.4x ↘ 5: 10.4x ↗
	Serie 75 Total 0		Serie 48 Total 48
30 Skott 	6: 10.3 ↘ 7: 10.6x ↘ 8: 10.1 ↗ 9: 10.3x ↗ 10: 10.3x ↗	30 Skott 	11: 10.4x ↗ 12: 10.1 ↗ 13: 10.4x ↗ 14: 9.1 ↗ 15: 8.8 ↘
	Serie 50 Total 98		Serie 47 Total 145
30 Skott 	16: 9.1 ↗ 17: 9.6 → 18: 9.8 ↘ 19: 10.1 ↘ 20: 10.2 →	30 Skott 	21: 9.7 ↗ 22: 10.1 ↗ 23: 9.8 → 24: 10.2 ↘ 25: 10.2 ←
	Serie 47 Total 192		Serie 48 Total 240
30 Skott 	26: 10.5x ↘ 27: 10.5x → 28: 10.5x ↗ 29: 9.6 ↗ 30: 10.6x ↘		
	Serie 49 Total 289		

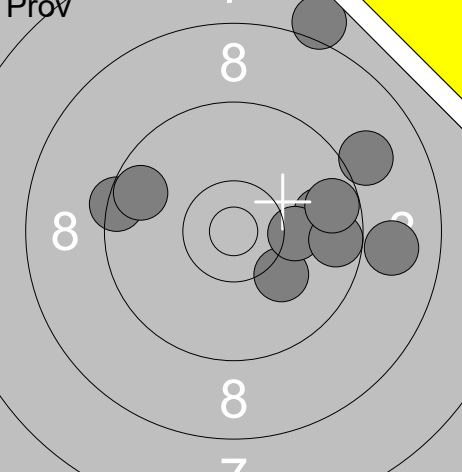
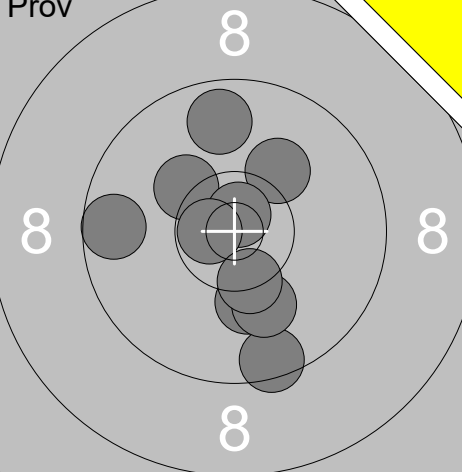
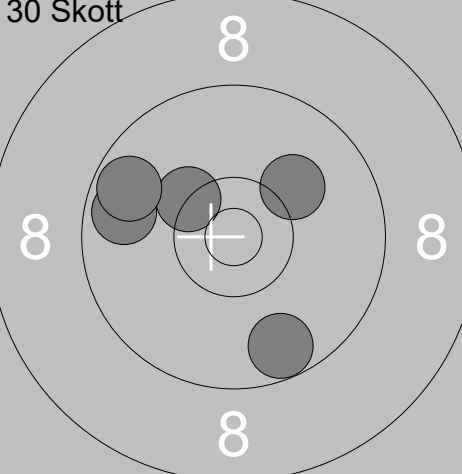
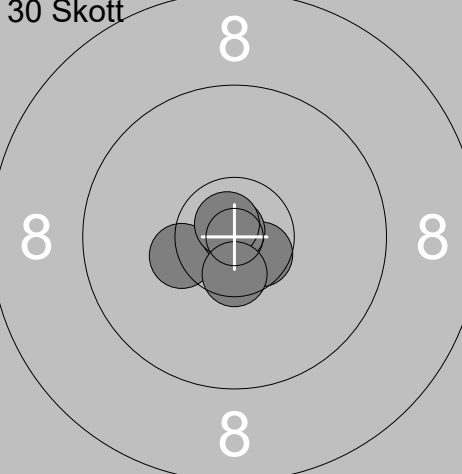
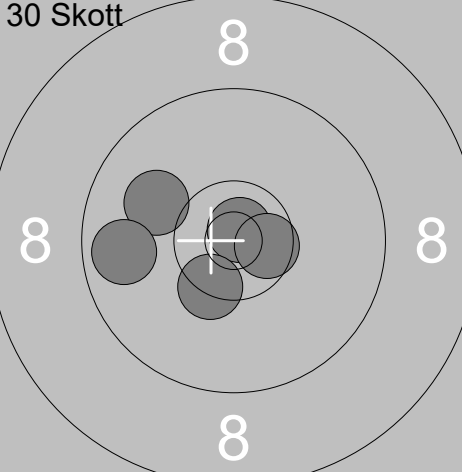
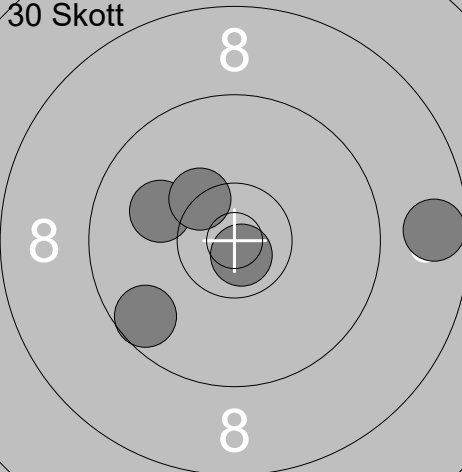
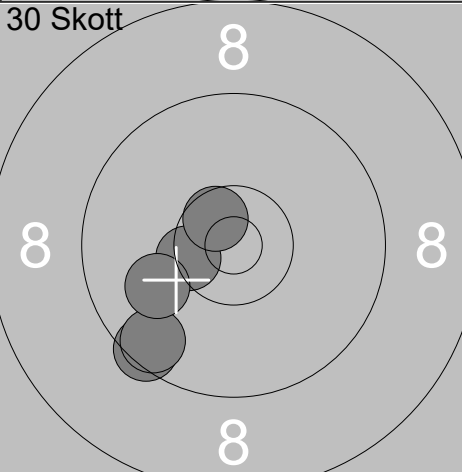
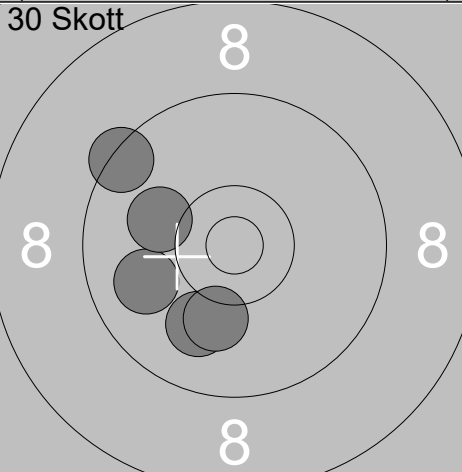
<p>Prov</p> 	<table border="1" style="width:100%; border-collapse: collapse;"> <tr><td>1:</td><td>8.9</td><td>→</td></tr> <tr><td>2:</td><td>10.1</td><td>↘</td></tr> <tr><td>3:</td><td>9.8</td><td>→</td></tr> <tr><td>4:</td><td>10.2</td><td>→</td></tr> <tr><td>5:</td><td>8.1</td><td>↗</td></tr> <tr><td>6:</td><td>9.4</td><td>←</td></tr> <tr><td>7:</td><td>9.0</td><td>↗</td></tr> <tr><td>8:</td><td>9.6</td><td>→</td></tr> <tr><td>9:</td><td>9.7</td><td>→</td></tr> <tr><td>10:</td><td>9.7</td><td>↖</td></tr> <tr><td colspan="2">Serie</td><td style="text-align: right;">90</td></tr> <tr><td colspan="2">Total</td><td style="text-align: right;">0</td></tr> </table>	1:	8.9	→	2:	10.1	↘	3:	9.8	→	4:	10.2	→	5:	8.1	↗	6:	9.4	←	7:	9.0	↗	8:	9.6	→	9:	9.7	→	10:	9.7	↖	Serie		90	Total		0	<p>Prov</p>  <table border="1" style="width:100%; border-collapse: collapse;"> <tr><td>11:</td><td>9.5</td><td>↓</td></tr> <tr><td>12:</td><td>9.7</td><td>↑</td></tr> <tr><td>13:</td><td>10.2</td><td>↓</td></tr> <tr><td>14:</td><td>10.1</td><td>↗</td></tr> <tr><td>15:</td><td>10.2</td><td>↗</td></tr> <tr><td>16:</td><td>10.8x</td><td>↑</td></tr> <tr><td>17:</td><td>10.1</td><td>↓</td></tr> <tr><td>18:</td><td>9.6</td><td>←</td></tr> <tr><td>19:</td><td>10.7x</td><td>←</td></tr> <tr><td>20:</td><td>10.4x</td><td>↓</td></tr> <tr><td colspan="2">Serie</td><td style="text-align: right;">97</td></tr> <tr><td colspan="2">Total</td><td style="text-align: right;">0</td></tr> </table>	11:	9.5	↓	12:	9.7	↑	13:	10.2	↓	14:	10.1	↗	15:	10.2	↗	16:	10.8x	↑	17:	10.1	↓	18:	9.6	←	19:	10.7x	←	20:	10.4x	↓	Serie		97	Total		0
1:	8.9	→																																																																								
2:	10.1	↘																																																																								
3:	9.8	→																																																																								
4:	10.2	→																																																																								
5:	8.1	↗																																																																								
6:	9.4	←																																																																								
7:	9.0	↗																																																																								
8:	9.6	→																																																																								
9:	9.7	→																																																																								
10:	9.7	↖																																																																								
Serie		90																																																																								
Total		0																																																																								
11:	9.5	↓																																																																								
12:	9.7	↑																																																																								
13:	10.2	↓																																																																								
14:	10.1	↗																																																																								
15:	10.2	↗																																																																								
16:	10.8x	↑																																																																								
17:	10.1	↓																																																																								
18:	9.6	←																																																																								
19:	10.7x	←																																																																								
20:	10.4x	↓																																																																								
Serie		97																																																																								
Total		0																																																																								
<p>30 Skott</p>  <table border="1" style="width:100%; border-collapse: collapse;"> <tr><td>1:</td><td>10.3x</td><td>↗</td></tr> <tr><td>2:</td><td>10.1</td><td>↗</td></tr> <tr><td>3:</td><td>9.7</td><td>←</td></tr> <tr><td>4:</td><td>9.7</td><td>↗</td></tr> <tr><td>5:</td><td>9.7</td><td>↘</td></tr> <tr><td colspan="2">Serie</td><td style="text-align: right;">47</td></tr> <tr><td colspan="2">Total</td><td style="text-align: right;">47</td></tr> </table>	1:	10.3x	↗	2:	10.1	↗	3:	9.7	←	4:	9.7	↗	5:	9.7	↘	Serie		47	Total		47	<p>30 Skott</p>  <table border="1" style="width:100%; border-collapse: collapse;"> <tr><td>6:</td><td>10.6x</td><td>↘</td></tr> <tr><td>7:</td><td>10.3x</td><td>←</td></tr> <tr><td>8:</td><td>10.9x</td><td>↑</td></tr> <tr><td>9:</td><td>10.8x</td><td>↗</td></tr> <tr><td>10:</td><td>10.5x</td><td>↓</td></tr> <tr><td colspan="2">Serie</td><td style="text-align: right;">50</td></tr> <tr><td colspan="2">Total</td><td style="text-align: right;">97</td></tr> </table>	6:	10.6x	↘	7:	10.3x	←	8:	10.9x	↑	9:	10.8x	↗	10:	10.5x	↓	Serie		50	Total		97																															
1:	10.3x	↗																																																																								
2:	10.1	↗																																																																								
3:	9.7	←																																																																								
4:	9.7	↗																																																																								
5:	9.7	↘																																																																								
Serie		47																																																																								
Total		47																																																																								
6:	10.6x	↘																																																																								
7:	10.3x	←																																																																								
8:	10.9x	↑																																																																								
9:	10.8x	↗																																																																								
10:	10.5x	↓																																																																								
Serie		50																																																																								
Total		97																																																																								
<p>30 Skott</p>  <table border="1" style="width:100%; border-collapse: collapse;"> <tr><td>11:</td><td>10.8x</td><td>↗</td></tr> <tr><td>12:</td><td>10.0</td><td>↖</td></tr> <tr><td>13:</td><td>9.7</td><td>←</td></tr> <tr><td>14:</td><td>10.6x</td><td>→</td></tr> <tr><td>15:</td><td>10.4x</td><td>↘</td></tr> <tr><td colspan="2">Serie</td><td style="text-align: right;">49</td></tr> <tr><td colspan="2">Total</td><td style="text-align: right;">146</td></tr> </table>	11:	10.8x	↗	12:	10.0	↖	13:	9.7	←	14:	10.6x	→	15:	10.4x	↘	Serie		49	Total		146	<p>30 Skott</p>  <table border="1" style="width:100%; border-collapse: collapse;"> <tr><td>16:</td><td>8.7</td><td>→</td></tr> <tr><td>17:</td><td>9.6</td><td>←</td></tr> <tr><td>18:</td><td>10.8x</td><td>↓</td></tr> <tr><td>19:</td><td>10.1</td><td>←</td></tr> <tr><td>20:</td><td>10.3x</td><td>↗</td></tr> <tr><td colspan="2">Serie</td><td style="text-align: right;">47</td></tr> <tr><td colspan="2">Total</td><td style="text-align: right;">193</td></tr> </table>	16:	8.7	→	17:	9.6	←	18:	10.8x	↓	19:	10.1	←	20:	10.3x	↗	Serie		47	Total		193																															
11:	10.8x	↗																																																																								
12:	10.0	↖																																																																								
13:	9.7	←																																																																								
14:	10.6x	→																																																																								
15:	10.4x	↘																																																																								
Serie		49																																																																								
Total		146																																																																								
16:	8.7	→																																																																								
17:	9.6	←																																																																								
18:	10.8x	↓																																																																								
19:	10.1	←																																																																								
20:	10.3x	↗																																																																								
Serie		47																																																																								
Total		193																																																																								
<p>30 Skott</p>  <table border="1" style="width:100%; border-collapse: collapse;"> <tr><td>21:</td><td>10.4x</td><td>←</td></tr> <tr><td>22:</td><td>9.5</td><td>↘</td></tr> <tr><td>23:</td><td>10.6x</td><td>↗</td></tr> <tr><td>24:</td><td>9.6</td><td>↘</td></tr> <tr><td>25:</td><td>10.0</td><td>←</td></tr> <tr><td colspan="2">Serie</td><td style="text-align: right;">48</td></tr> <tr><td colspan="2">Total</td><td style="text-align: right;">241</td></tr> </table>	21:	10.4x	←	22:	9.5	↘	23:	10.6x	↗	24:	9.6	↘	25:	10.0	←	Serie		48	Total		241	<p>30 Skott</p>  <table border="1" style="width:100%; border-collapse: collapse;"> <tr><td>26:</td><td>9.4</td><td>↖</td></tr> <tr><td>27:</td><td>10.0</td><td>↓</td></tr> <tr><td>28:</td><td>10.1</td><td>↓</td></tr> <tr><td>29:</td><td>9.9</td><td>←</td></tr> <tr><td>30:</td><td>10.1</td><td>←</td></tr> <tr><td colspan="2">Serie</td><td style="text-align: right;">48</td></tr> <tr><td colspan="2">Total</td><td style="text-align: right;">289</td></tr> </table>	26:	9.4	↖	27:	10.0	↓	28:	10.1	↓	29:	9.9	←	30:	10.1	←	Serie		48	Total		289																															
21:	10.4x	←																																																																								
22:	9.5	↘																																																																								
23:	10.6x	↗																																																																								
24:	9.6	↘																																																																								
25:	10.0	←																																																																								
Serie		48																																																																								
Total		241																																																																								
26:	9.4	↖																																																																								
27:	10.0	↓																																																																								
28:	10.1	↓																																																																								
29:	9.9	←																																																																								
30:	10.1	←																																																																								
Serie		48																																																																								
Total		289																																																																								

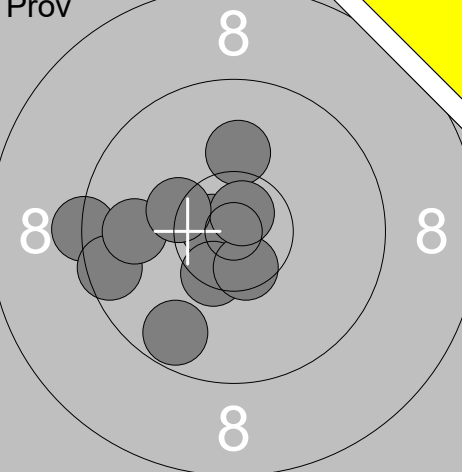
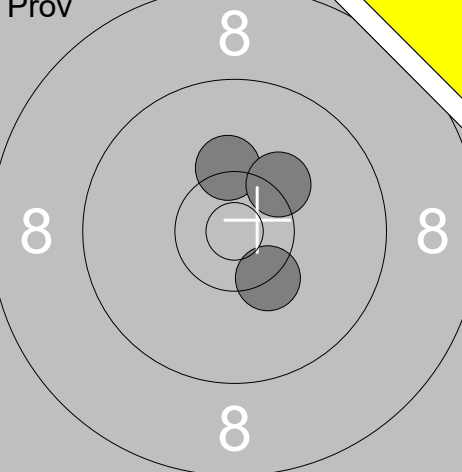
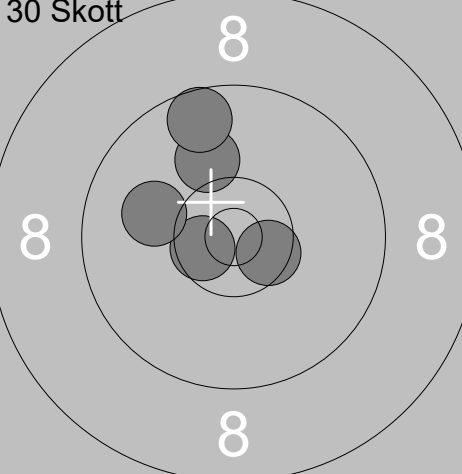
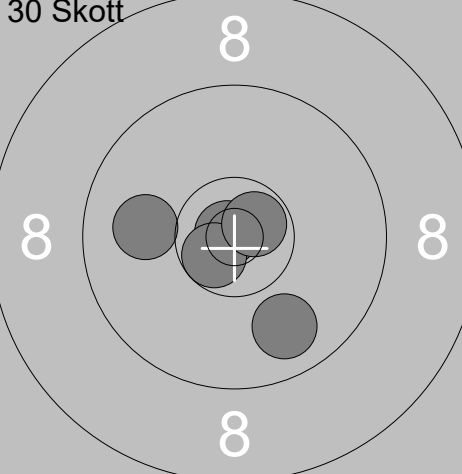
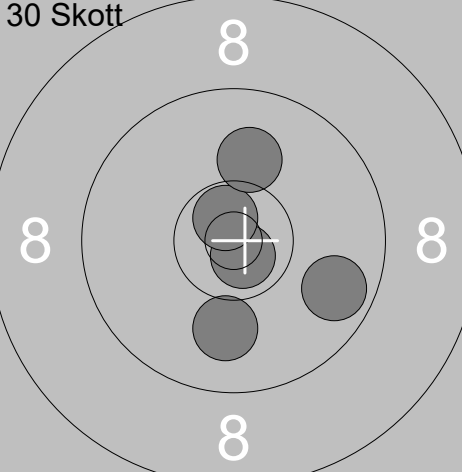
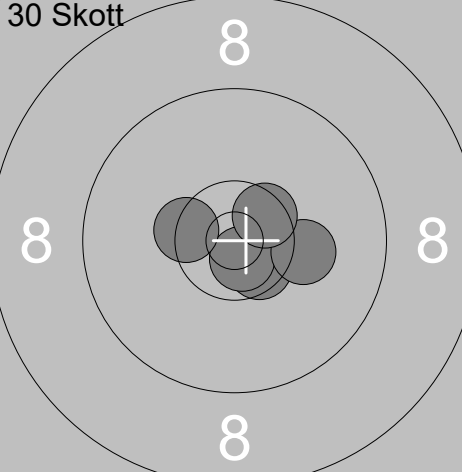
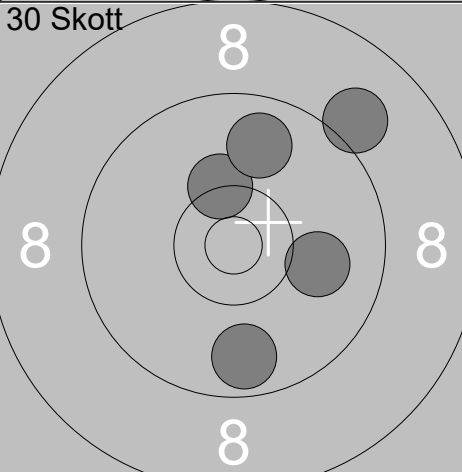
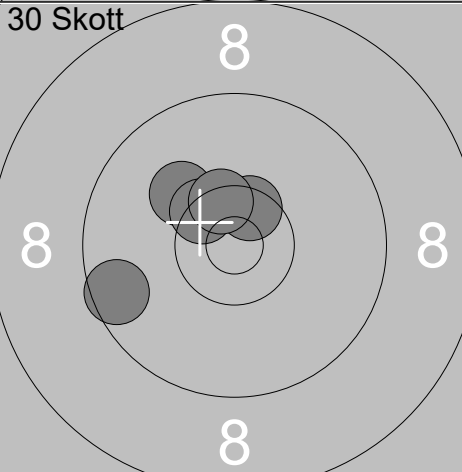
<p>Prov</p> 	<p>1: 9.3 ← 2: 9.5 ← 3: 9.7 ↘ 4: 10.1 ↑ 5: 10.7x ← 6: 9.9 ← 7: 10.4x ↘ 8: 10.5x ↘ 9: 10.7x ↗ 10: 10.3x ←</p> <p>Serie 96 Total 0</p>	<p>Prov</p> 	<p>11: 10.3x ↘ 12: 10.3 ↑ 13: 10.3 ↗</p> <p>Serie 30 Total 0</p>
<p>30 Skott</p> 	<p>1: 10.1 ↗ 2: 9.6 ↑ 3: 10.6x ← 4: 10.5x ↘ 5: 10.1 ←</p> <p>Serie 49 Total 49</p>	<p>30 Skott</p> 	<p>6: 9.8 ↘ 7: 10.9x ↖ 8: 10.0 ← 9: 10.7x ↘ 10: 10.7x ↗</p> <p>Serie 49 Total 98</p>
<p>30 Skott</p> 	<p>11: 10.0 ↘ 12: 9.7 ↘ 13: 10.8x ↘ 14: 10.7x ↗ 15: 10.1 ↑</p> <p>Serie 49 Total 147</p>	<p>30 Skott</p> 	<p>16: 10.6x ↘ 17: 10.7x ↘ 18: 10.2 → 19: 10.5x ↗ 20: 10.4x ←</p> <p>Serie 50 Total 197</p>
<p>30 Skott</p> 	<p>21: 9.1 ↗ 22: 10.3x ↑ 23: 9.8 ↑ 24: 9.7 ↘ 25: 10.0 →</p> <p>Serie 47 Total 244</p>	<p>30 Skott</p> 	<p>26: 10.1 ↗ 27: 10.4x ↖ 28: 10.5x ↗ 29: 9.6 ← 30: 10.4x ↑</p> <p>Serie 49 Total 293</p>

Skjutlag	Tavla	Mats Österlund	
1	11	Ramselefors	Vb
28.04.2019	Vindelnskottet 2019	Ramselefors SKF	
Prov	1: 9.6 ↗ 2: 10.6x ↘ 3: 10.2 ↗ 4: 9.1 ↘ 5: 8.7 ← 6: 9.2 ↘ 7: 9.4 ↘ 8: 9.2 ↙ 9: 10.3x ↘ Serie 83 Total 0	30 Skott	1: 10.3x ↑ 2: 8.9 ← 3: 10.4x ↗ 4: 10.7x ↗ 5: 9.6 ↘ Serie 47 Total 47
30 Skott	6: 8.2 ↘ 7: 9.7 ↘ 8: 9.9 ↑ 9: 10.3x ↘ 10: 10.8x ↑ Serie 46 Total 93	30 Skott	11: 8.7 ↘ 12: 8.1 ↘ 13: 10.0 ↘ 14: 10.0 ↑ 15: 9.2 ↘ Serie 45 Total 138
30 Skott	16: 9.4 ↗ 17: 10.3x ← 18: 9.8 ↗ 19: 10.7x ↘ 20: 9.9 ↗ Serie 47 Total 185	30 Skott	21: 10.3 ↘ 22: 10.6x ↑ 23: 9.4 ↘ 24: 10.1 ↗ 25: 9.5 ↘ Serie 48 Total 233
30 Skott	26: 10.3x ↘ 27: 10.6x ↘ 28: 8.3 ↗ 29: 10.7x ↘ 30: 10.8x ← Serie 48 Total 281		

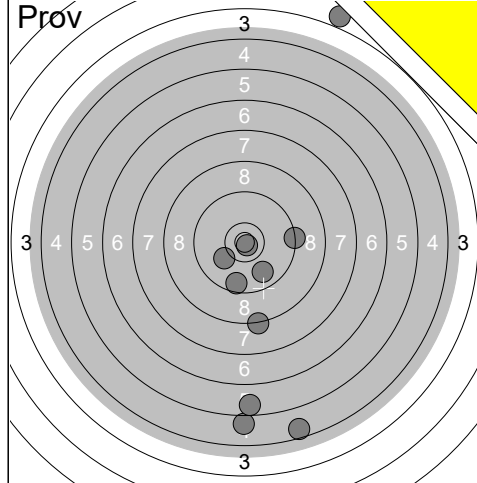

1:	2.9	↗
2:	5.0	↓
3:	4.6	↓
4:	5.6	↓
5:	9.8	↓
6:	8.3	↓
7:	9.3	→
8:	10.1	↖
9:	10.8x	↓
10:	9.6	↓
Serie		71
Total		0

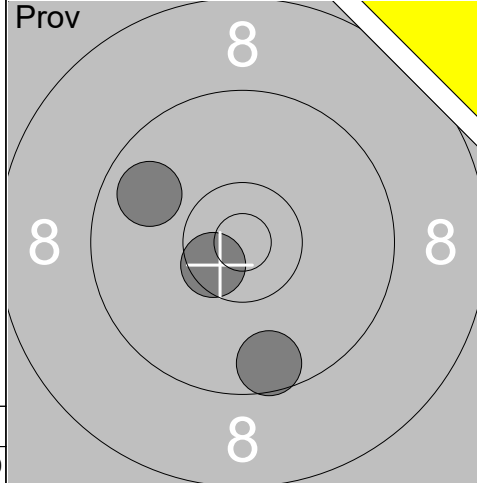

11:	9.8	↖
12:	10.5x	↖
13:	9.6	↓
Serie		28
Total		0

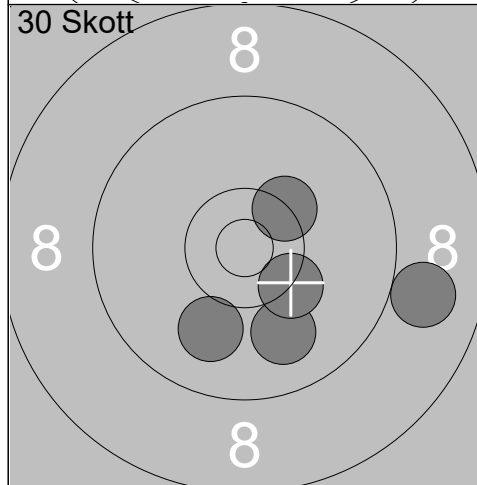

1:	10.3x	↗
2:	8.9	→
3:	10.0	↓
4:	9.9	↓
5:	10.3x	↓
Serie		47
Total		47

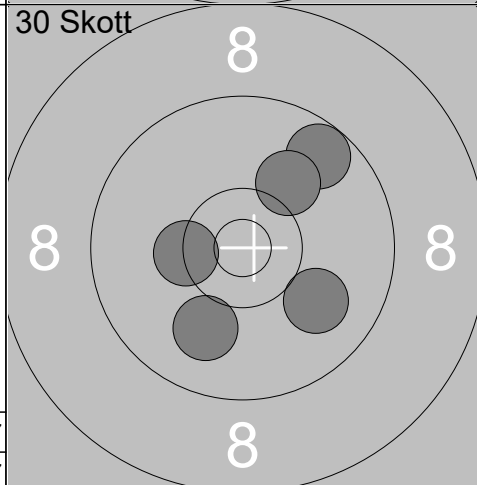

6:	10.0	↓
7:	9.7	↗
8:	10.1	↗
9:	10.3x	←
10:	10.0	↘
Serie		49
Total		96

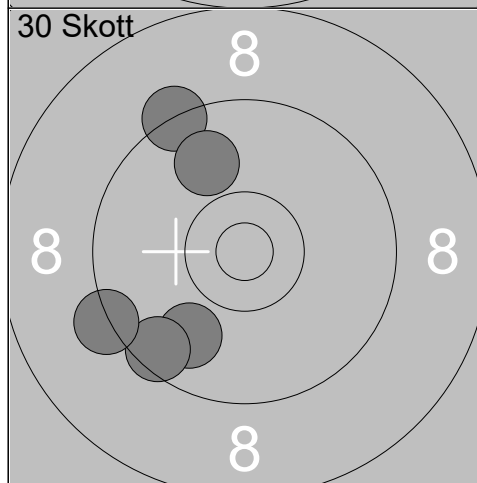

11:	9.9	↖
12:	9.3	↗
13:	9.9	↗
14:	9.5	↖
15:	9.3	↖
Serie		45
Total		141

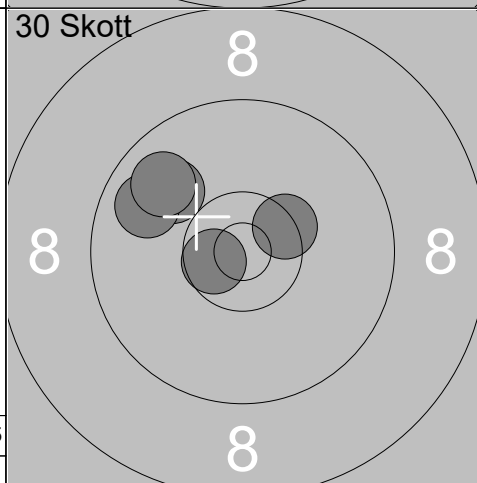

16:	9.9	↖
17:	9.8	↖
18:	10.6x	←
19:	10.4x	↗
20:	9.8	↗
Serie		47
Total		188

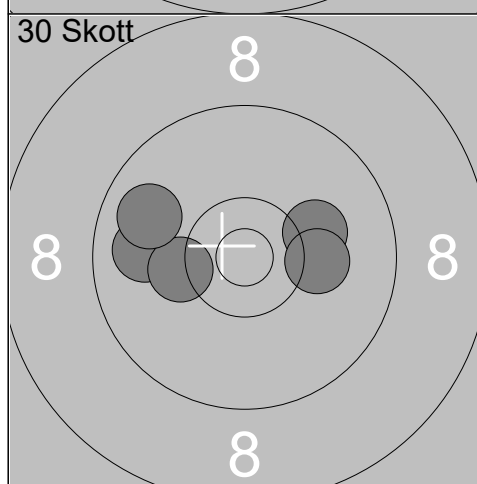

21:	10.1	→
22:	10.2	→
23:	9.9	←
24:	10.2	←
25:	9.8	↖
Serie		48
Total		236

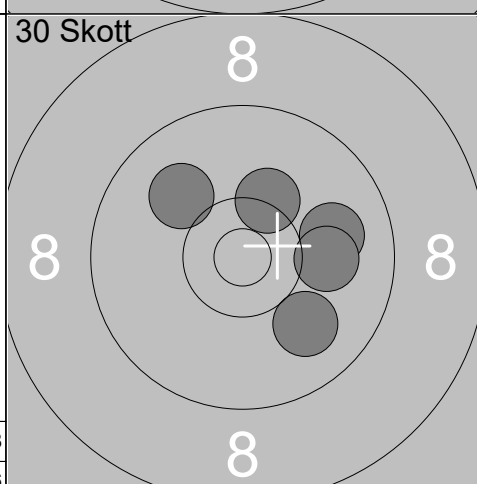

26:	10.0	→
27:	10.0	↖
28:	10.3	↗
29:	10.0	↓
30:	10.0	→
Serie		50
Total		286

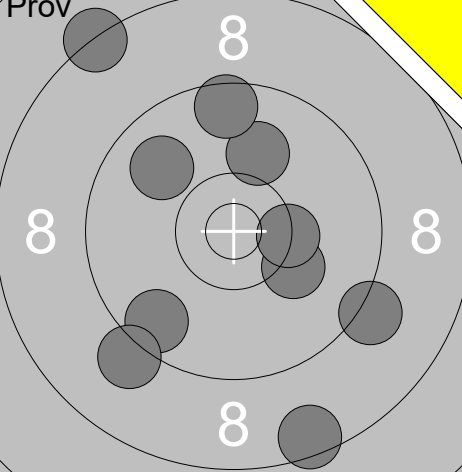
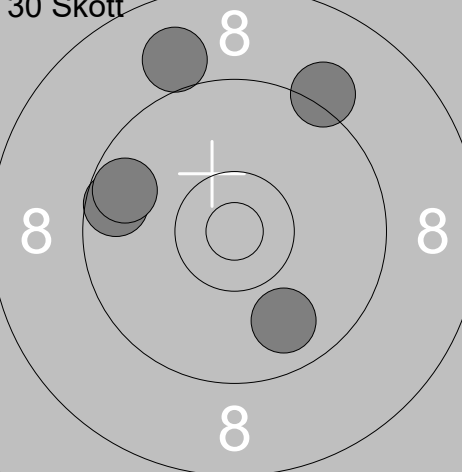
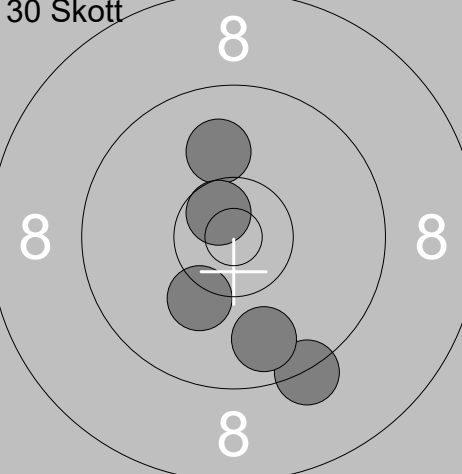
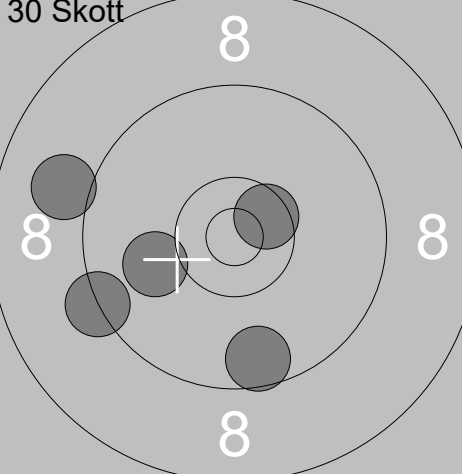
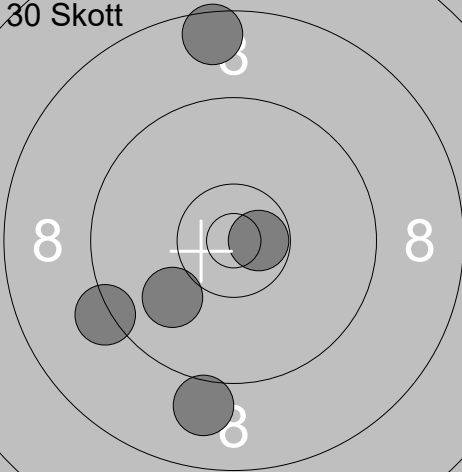
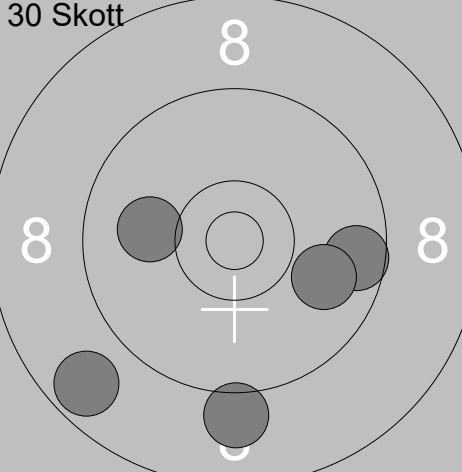
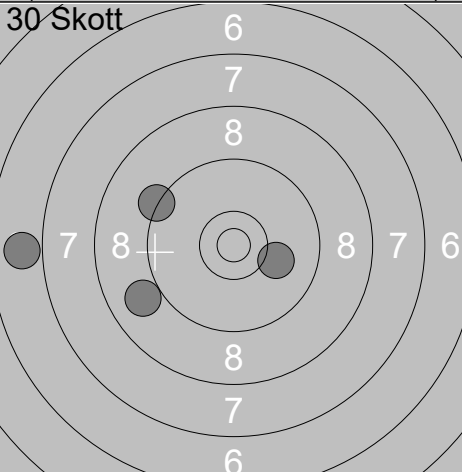
	<table style="width:100%; border-collapse: collapse;"> <tr><td>1: 8.5</td><td style="text-align:right;">↘</td></tr> <tr><td>2: 9.9</td><td style="text-align:right;">↗</td></tr> <tr><td>3: 10.0</td><td style="text-align:right;">↗</td></tr> <tr><td>4: 9.6</td><td style="text-align:right;">↘</td></tr> <tr><td>5: 9.2</td><td style="text-align:right;">↘</td></tr> <tr><td>6: 10.2</td><td style="text-align:right;">↘</td></tr> <tr><td>7: 9.1</td><td style="text-align:right;">↘</td></tr> <tr><td>8: 9.6</td><td style="text-align:right;">↗</td></tr> <tr><td>9: 8.3</td><td style="text-align:right;">↗</td></tr> <tr><td>10: 10.3x</td><td style="text-align:right;">→</td></tr> <tr><td colspan="2"><hr/></td></tr> <tr><td>Serie</td><td style="text-align:right;">91</td></tr> <tr><td>Total</td><td style="text-align:right;">0</td></tr> </table>	1: 8.5	↘	2: 9.9	↗	3: 10.0	↗	4: 9.6	↘	5: 9.2	↘	6: 10.2	↘	7: 9.1	↘	8: 9.6	↗	9: 8.3	↗	10: 10.3x	→	<hr/>		Serie	91	Total	0	 <table style="width:100%; border-collapse: collapse;"> <tr><td>1: 9.8</td><td style="text-align:right;">↘</td></tr> <tr><td>2: 9.2</td><td style="text-align:right;">↗</td></tr> <tr><td>3: 9.6</td><td style="text-align:right;">↖</td></tr> <tr><td>4: 9.0</td><td style="text-align:right;">↗</td></tr> <tr><td>5: 9.7</td><td style="text-align:right;">↖</td></tr> <tr><td colspan="2"><hr/></td></tr> <tr><td>Serie</td><td style="text-align:right;">45</td></tr> <tr><td>Total</td><td style="text-align:right;">45</td></tr> </table>	1: 9.8	↘	2: 9.2	↗	3: 9.6	↖	4: 9.0	↗	5: 9.7	↖	<hr/>		Serie	45	Total	45
1: 8.5	↘																																											
2: 9.9	↗																																											
3: 10.0	↗																																											
4: 9.6	↘																																											
5: 9.2	↘																																											
6: 10.2	↘																																											
7: 9.1	↘																																											
8: 9.6	↗																																											
9: 8.3	↗																																											
10: 10.3x	→																																											
<hr/>																																												
Serie	91																																											
Total	0																																											
1: 9.8	↘																																											
2: 9.2	↗																																											
3: 9.6	↖																																											
4: 9.0	↗																																											
5: 9.7	↖																																											
<hr/>																																												
Serie	45																																											
Total	45																																											
	<table style="width:100%; border-collapse: collapse;"> <tr><td>6: 10.2</td><td style="text-align:right;">↘</td></tr> <tr><td>7: 10.0</td><td style="text-align:right;">↗</td></tr> <tr><td>8: 10.6x</td><td style="text-align:right;">↗</td></tr> <tr><td>9: 9.3</td><td style="text-align:right;">↘</td></tr> <tr><td>10: 9.8</td><td style="text-align:right;">↘</td></tr> <tr><td colspan="2"><hr/></td></tr> <tr><td>Serie</td><td style="text-align:right;">48</td></tr> <tr><td>Total</td><td style="text-align:right;">93</td></tr> </table>	6: 10.2	↘	7: 10.0	↗	8: 10.6x	↗	9: 9.3	↘	10: 9.8	↘	<hr/>		Serie	48	Total	93	 <table style="width:100%; border-collapse: collapse;"> <tr><td>11: 9.6</td><td style="text-align:right;">↘</td></tr> <tr><td>12: 9.3</td><td style="text-align:right;">↖</td></tr> <tr><td>13: 10.0</td><td style="text-align:right;">↖</td></tr> <tr><td>14: 9.0</td><td style="text-align:right;">↖</td></tr> <tr><td>15: 10.5x</td><td style="text-align:right;">↗</td></tr> <tr><td colspan="2"><hr/></td></tr> <tr><td>Serie</td><td style="text-align:right;">47</td></tr> <tr><td>Total</td><td style="text-align:right;">140</td></tr> </table>	11: 9.6	↘	12: 9.3	↖	13: 10.0	↖	14: 9.0	↖	15: 10.5x	↗	<hr/>		Serie	47	Total	140										
6: 10.2	↘																																											
7: 10.0	↗																																											
8: 10.6x	↗																																											
9: 9.3	↘																																											
10: 9.8	↘																																											
<hr/>																																												
Serie	48																																											
Total	93																																											
11: 9.6	↘																																											
12: 9.3	↖																																											
13: 10.0	↖																																											
14: 9.0	↖																																											
15: 10.5x	↗																																											
<hr/>																																												
Serie	47																																											
Total	140																																											
	<table style="width:100%; border-collapse: collapse;"> <tr><td>16: 10.7x</td><td style="text-align:right;">→</td></tr> <tr><td>17: 9.2</td><td style="text-align:right;">↖</td></tr> <tr><td>18: 9.0</td><td style="text-align:right;">↘</td></tr> <tr><td>19: 8.6</td><td style="text-align:right;">↗</td></tr> <tr><td>20: 10.0</td><td style="text-align:right;">↖</td></tr> <tr><td colspan="2"><hr/></td></tr> <tr><td>Serie</td><td style="text-align:right;">46</td></tr> <tr><td>Total</td><td style="text-align:right;">186</td></tr> </table>	16: 10.7x	→	17: 9.2	↖	18: 9.0	↘	19: 8.6	↗	20: 10.0	↖	<hr/>		Serie	46	Total	186	 <table style="width:100%; border-collapse: collapse;"> <tr><td>21: 9.6</td><td style="text-align:right;">→</td></tr> <tr><td>22: 9.9</td><td style="text-align:right;">→</td></tr> <tr><td>23: 9.1</td><td style="text-align:right;">↘</td></tr> <tr><td>24: 10.0</td><td style="text-align:right;">↖</td></tr> <tr><td>25: 8.7</td><td style="text-align:right;">↖</td></tr> <tr><td colspan="2"><hr/></td></tr> <tr><td>Serie</td><td style="text-align:right;">45</td></tr> <tr><td>Total</td><td style="text-align:right;">231</td></tr> </table>	21: 9.6	→	22: 9.9	→	23: 9.1	↘	24: 10.0	↖	25: 8.7	↖	<hr/>		Serie	45	Total	231										
16: 10.7x	→																																											
17: 9.2	↖																																											
18: 9.0	↘																																											
19: 8.6	↗																																											
20: 10.0	↖																																											
<hr/>																																												
Serie	46																																											
Total	186																																											
21: 9.6	→																																											
22: 9.9	→																																											
23: 9.1	↘																																											
24: 10.0	↖																																											
25: 8.7	↖																																											
<hr/>																																												
Serie	45																																											
Total	231																																											
	<table style="width:100%; border-collapse: collapse;"> <tr><td>26: 9.0</td><td style="text-align:right;">↖</td></tr> <tr><td>27: 6.9</td><td style="text-align:right;">↖</td></tr> <tr><td>28: 10.1</td><td style="text-align:right;">↗</td></tr> <tr><td>29: 9.3</td><td style="text-align:right;">↗</td></tr> <tr><td>30: 0.0</td><td style="text-align:right;"></td></tr> <tr><td colspan="2"><hr/></td></tr> <tr><td>Serie</td><td style="text-align:right;">34</td></tr> <tr><td>Total</td><td style="text-align:right;">265</td></tr> </table>	26: 9.0	↖	27: 6.9	↖	28: 10.1	↗	29: 9.3	↗	30: 0.0		<hr/>		Serie	34	Total	265																											
26: 9.0	↖																																											
27: 6.9	↖																																											
28: 10.1	↗																																											
29: 9.3	↗																																											
30: 0.0																																												
<hr/>																																												
Serie	34																																											
Total	265																																											

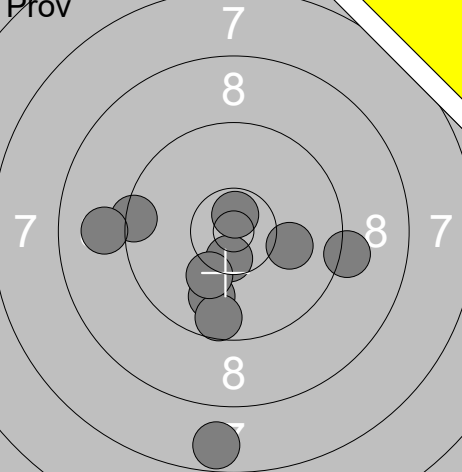
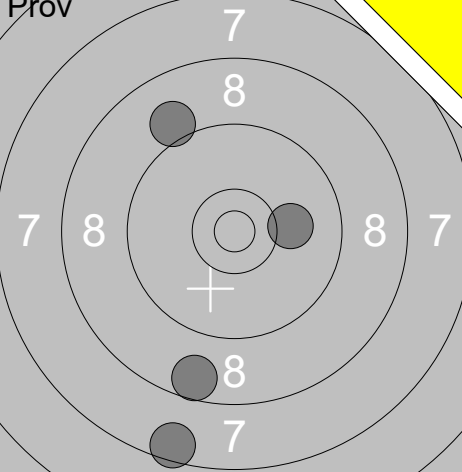
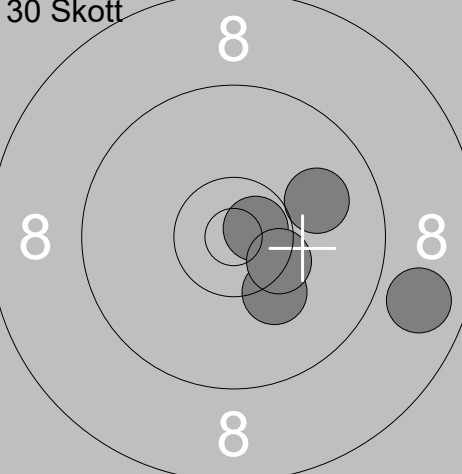
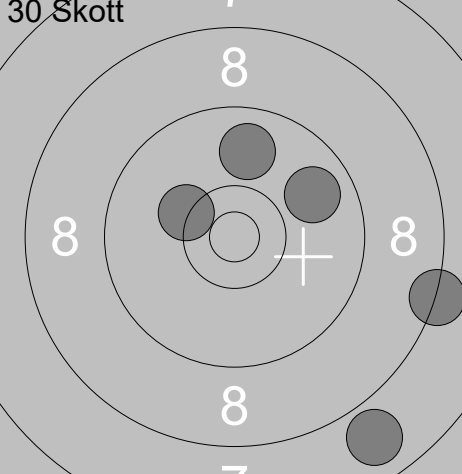
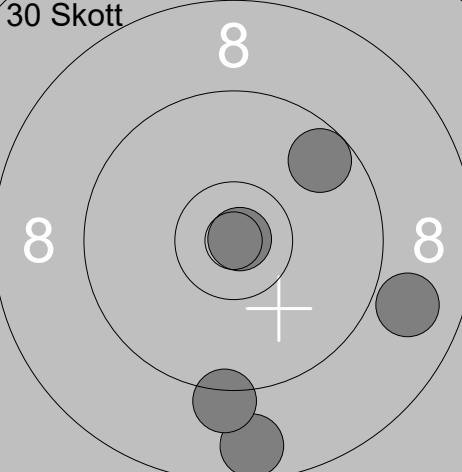
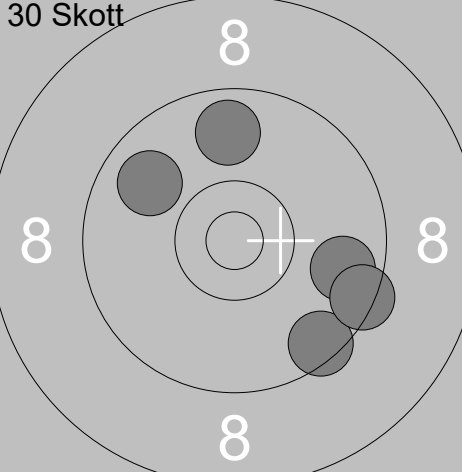
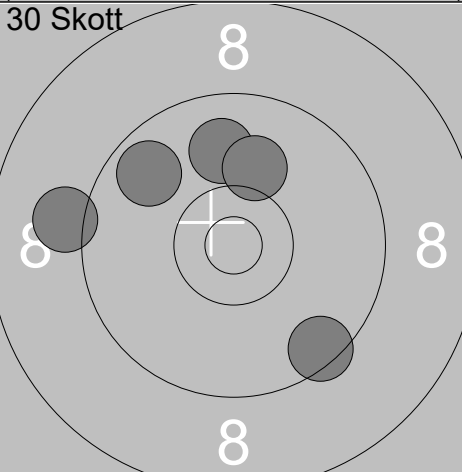
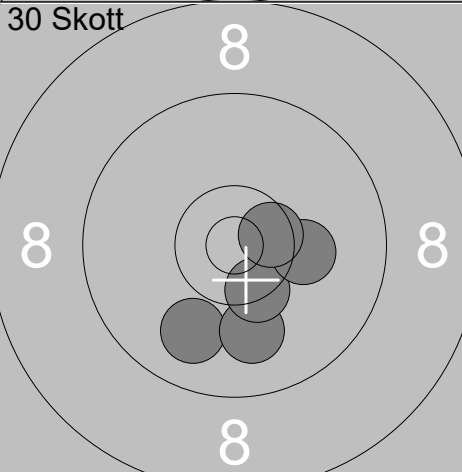
Prov 	1: 9.4 ← 2: 7.7 ↓ 3: 10.5x ↓ 4: 9.2 → 5: 9.0 ← 6: 10.1 → 7: 9.9 ↓ 8: 9.6 ↓ 9: 10.2 ↓ 10: 10.7x ↑ <hr/> Serie 92 Total 0	Prov 	11: 7.5 ↓ 12: 9.1 ↗ 13: 8.6 ↓ 14: 10.1 → <hr/> Serie 34 Total 0
30 Skott 	1: 10.2 ↓ 2: 10.7x → 3: 10.0 → 4: 10.4x → 5: 8.8 → <hr/> Serie 48 Total 48	30 Skott 	6: 10.3 ↖ 7: 7.9 ↓ 8: 9.8 → 9: 8.3 → 10: 9.9 ↑ <hr/> Serie 43 Total 91
30 Skott 	11: 10.9x → 12: 9.6 ↗ 13: 8.7 ↓ 14: 9.2 ↓ 15: 8.9 ↘ <hr/> Serie 44 Total 135	30 Skott 	16: 9.5 ↓ 17: 9.7 → 18: 9.4 → 19: 9.8 ↗ 20: 9.8 ↑ <hr/> Serie 45 Total 180
30 Skott 	21: 9.7 ↗ 22: 9.9 ↑ 23: 9.5 ↓ 24: 10.1 ↑ 25: 9.1 ← <hr/> Serie 46 Total 226	30 Skott 	26: 9.9 ↓ 27: 10.0 ↓ 28: 10.4x ↓ 29: 10.2 → 30: 10.5x → <hr/> Serie 49 Total 275

<p>Prov</p>	<p>1: 9.9 ↘ 2: 7.3 → 3: 9.5 ↑ 4: 9.4 → 5: 10.2 ↘ 6: 9.5 → 7: 10.5x → 8: 9.5 ↘ 9: 9.3 ↘ 10: 10.4x ↘</p> <p>Serie 91 Total 0</p>	<p>Prov</p>	<p>11: 8.9 ↘ 12: 9.5 ↘ 13: 10.3x ↘</p> <p>Serie 27 Total 0</p>
<p>30 Skott</p>	<p>1: 9.7 → 2: 9.5 ↘ 3: 9.5 → 4: 10.9x ↘ 5: 10.2 ↘</p> <p>Serie 47 Total 47</p>	<p>30 Skott</p>	<p>6: 9.9 ↘ 7: 10.0 ↘ 8: 9.9 ↑ 9: 9.9 ↘ 10: 9.6 →</p> <p>Serie 46 Total 93</p>
<p>30 Skott</p>	<p>11: 9.1 ↘ 12: 8.3 ↘ 13: 10.0 → 14: 10.1 ↘ 15: 9.7 ↘</p> <p>Serie 46 Total 139</p>	<p>30 Skott</p>	<p>16: 10.5x ↗ 17: 10.7x ↑ 18: 10.5x ↘ 19: 10.4x ↘ 20: 9.3 →</p> <p>Serie 49 Total 188</p>
<p>30 Skott</p>	<p>21: 9.6 ↘ 22: 10.1 ↘ 23: 9.2 ↗ 24: 9.0 ↘ 25: 10.1 ↖</p> <p>Serie 47 Total 235</p>	<p>30 Skott</p>	<p>26: 10.5x → 27: 10.7x ← 28: 9.5 ↖ 29: 9.7 ↗ 30: 9.1 →</p> <p>Serie 47 Total 282</p>

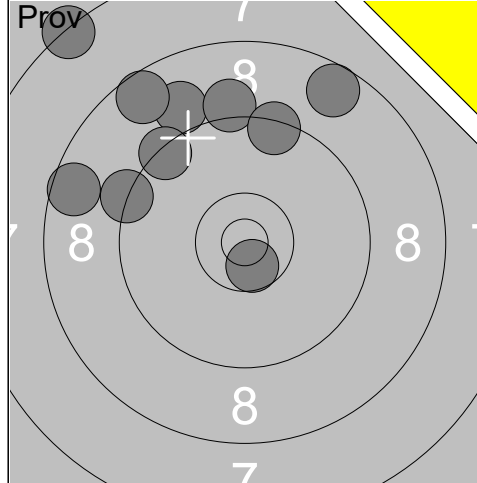

1:	8.6	↗
2:	7.3	↗
3:	9.0	↗
4:	9.1	↗
5:	9.4	↗
6:	10.6x	↘
7:	9.4	↗
8:	8.6	↖
9:	8.6	↗
10:	9.3	↖

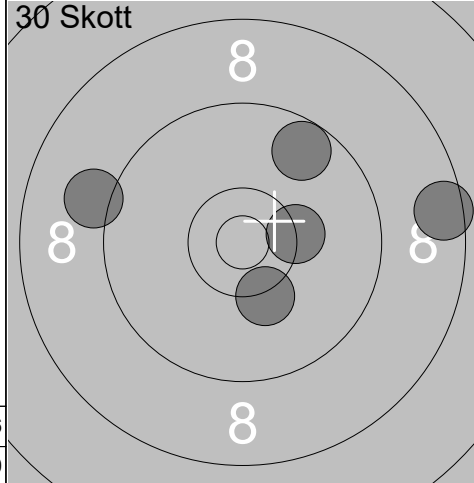

1:	9.7	↗
2:	8.5	→
3:	10.3x	→
4:	10.3	↘
5:	9.1	↖

Serie	86
Total	0

Serie	46
Total	46

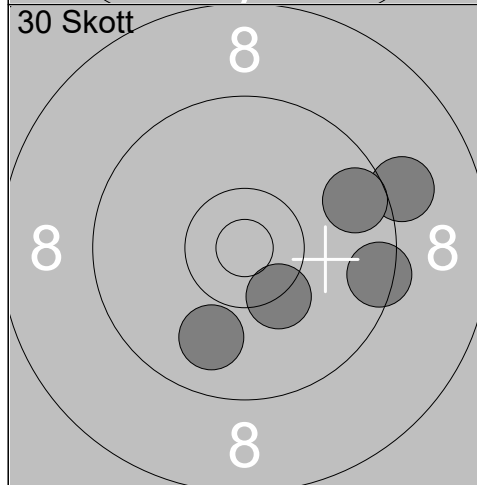

6:	9.1	→
7:	9.6	→
8:	10.3x	↘
9:	9.5	→
10:	9.9	↘

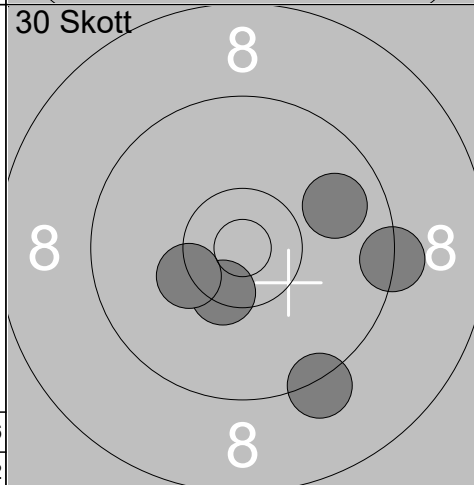

11:	9.2	↘
12:	9.8	→
13:	10.4x	↘
14:	9.3	→
15:	10.3x	↖

Serie	46
Total	92

Serie	47
Total	139

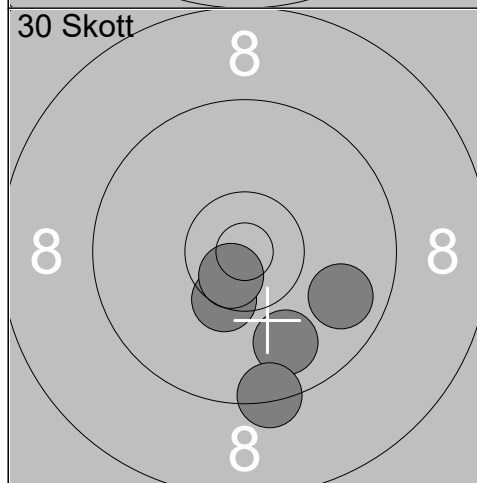

16:	9.8	→
17:	9.9	↘
18:	10.4x	↘
19:	9.4	↘
20:	10.6x	↘

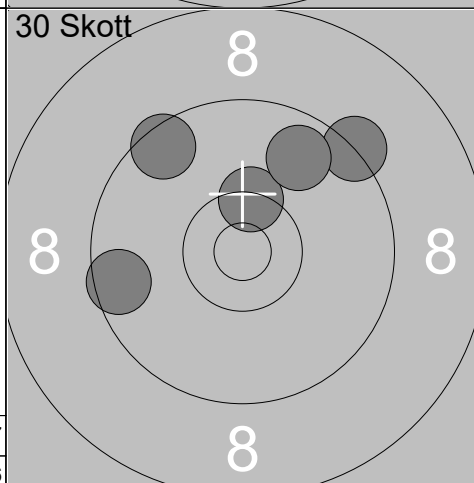

21:	9.5	↖
22:	10.4x	↑
23:	9.3	↗
24:	9.8	↗
25:	9.6	←

Serie	47
Total	186

Serie	46
Total	232

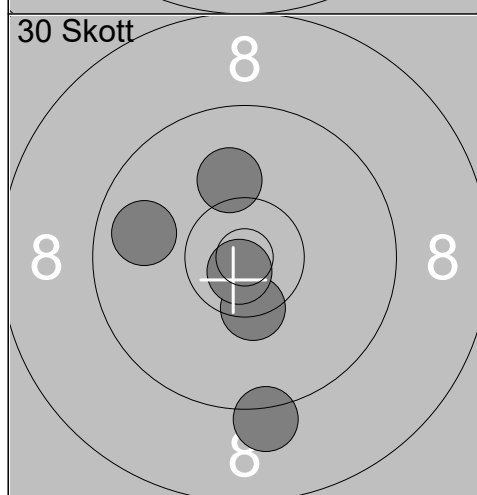

26:	9.8	←
27:	10.4x	↘
28:	10.8x	↘
29:	9.2	↘
30:	10.1	↗

Serie	48
Total	280

Skjutlag 2	Tavla 4	Hanna Augustsson	
Ramselefors		Vännäs	Vb
28.04.2019		Vindelnskottet 2019	Ramselefors SKF
	1: 2.4 ↘ 2: 4.2 ↘ 3: 4.2 ↘ 4: 6.5 ↘ 5: 6.3 ↘ 6: 7.4 ↘ 7: 7.1 ↘ 8: 9.6 ↑ 9: 7.3 ↑ 10: 9.3 → Serie 61 Total 0		11: 9.3 → 12: 9.1 ← 13: 10.8x ↓ 14: 9.9 ↙ 15: 10.2 ↗ 16: 9.2 ↗ 17: 9.5 ↑ 18: 10.5x ↓ 19: 9.9 → 20: 10.2 ↗ Serie 94 Total 0
	21: 10.5x → 22: 10.4x → Serie 20 Total 0		1: 9.8 → 2: 10.1 ↓ 3: 7.9 ← 4: 9.8 ← 5: 9.8 ← Serie 44 Total 44
	6: 9.7 → 7: 10.2 ↙ 8: 9.9 → 9: 9.4 ↑ 10: 9.4 → Serie 46 Total 90		11: 10.3 → 12: 10.8x → 13: 9.9 ← 14: 9.8 ↓ 15: 10.6x ↓ Serie 48 Total 138
	16: 9.3 ↓ 17: 10.5x ↓ 18: 9.0 ↓ 19: 9.3 ↓ 20: 9.5 ↓ Serie 46 Total 184		21: 9.5 → 22: 10.0 ↗ 23: 10.7x ↓ 24: 9.4 ↑ 25: 10.3x ↖ Serie 48 Total 232
	26: 9.4 ↑ 27: 9.5 ↓ 28: 9.4 ↑ 29: 10.3 ↓ 30: 10.1 ↓ Serie 47 Total 279		

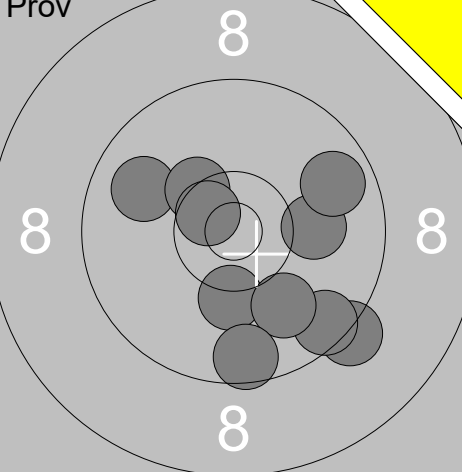
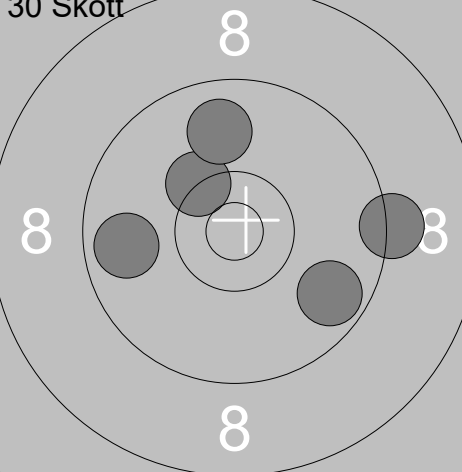
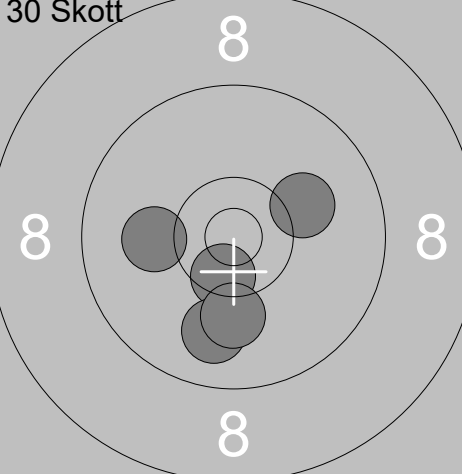
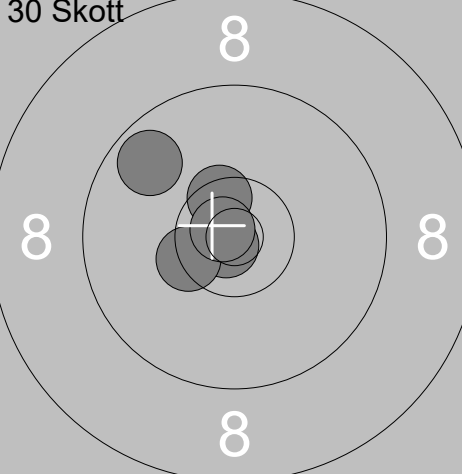
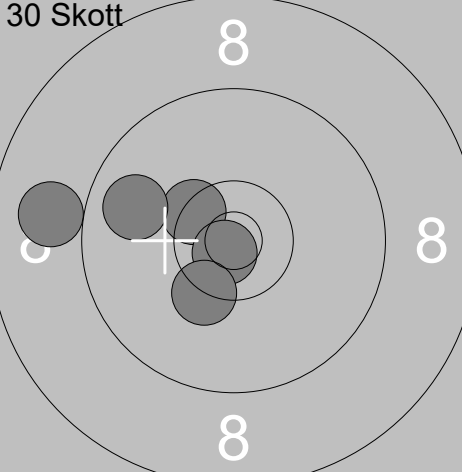
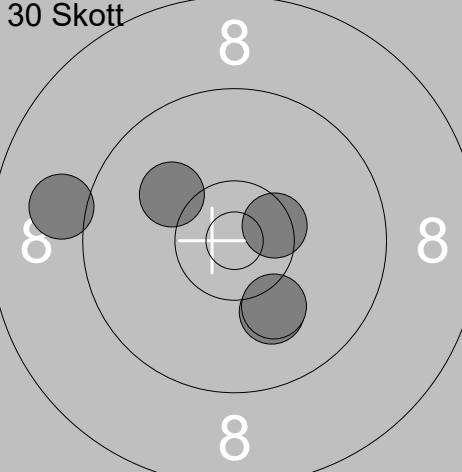
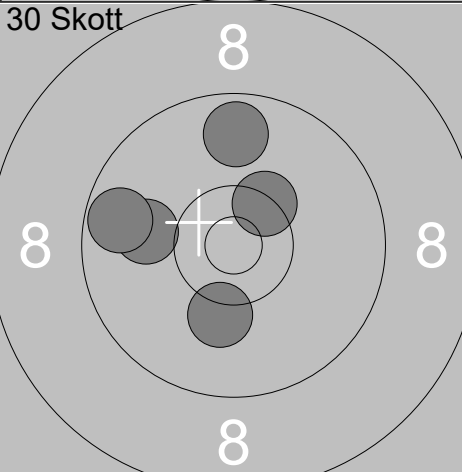
<p>Prov</p> 	<table style="width:100%; border-collapse: collapse;"> <tr><td>1:</td><td>9.9</td><td>↗</td></tr> <tr><td>2:</td><td>9.3</td><td>↘</td></tr> <tr><td>3:</td><td>10.1</td><td>→</td></tr> <tr><td>4:</td><td>10.3x</td><td>↗</td></tr> <tr><td>5:</td><td>9.8</td><td>→</td></tr> <tr><td>6:</td><td>10.2</td><td>↘</td></tr> <tr><td>7:</td><td>9.5</td><td>↘</td></tr> <tr><td>8:</td><td>10.0</td><td>↘</td></tr> <tr><td>9:</td><td>10.6x</td><td>↗</td></tr> <tr><td>10:</td><td>9.6</td><td>↓</td></tr> </table> <table style="width:100%; border-collapse: collapse;"> <tr><td>Serie</td><td style="text-align: right;">95</td></tr> <tr><td>Total</td><td style="text-align: right;">0</td></tr> </table>	1:	9.9	↗	2:	9.3	↘	3:	10.1	→	4:	10.3x	↗	5:	9.8	→	6:	10.2	↘	7:	9.5	↘	8:	10.0	↘	9:	10.6x	↗	10:	9.6	↓	Serie	95	Total	0	<p>30 Skott</p>  <table style="width:100%; border-collapse: collapse;"> <tr><td>1:</td><td>9.8</td><td>←</td></tr> <tr><td>2:</td><td>10.3x</td><td>↗</td></tr> <tr><td>3:</td><td>9.2</td><td>→</td></tr> <tr><td>4:</td><td>9.9</td><td>↑</td></tr> <tr><td>5:</td><td>9.7</td><td>↘</td></tr> </table> <table style="width:100%; border-collapse: collapse;"> <tr><td>Serie</td><td style="text-align: right;">46</td></tr> <tr><td>Total</td><td style="text-align: right;">46</td></tr> </table>	1:	9.8	←	2:	10.3x	↗	3:	9.2	→	4:	9.9	↑	5:	9.7	↘	Serie	46	Total	46
1:	9.9	↗																																																					
2:	9.3	↘																																																					
3:	10.1	→																																																					
4:	10.3x	↗																																																					
5:	9.8	→																																																					
6:	10.2	↘																																																					
7:	9.5	↘																																																					
8:	10.0	↘																																																					
9:	10.6x	↗																																																					
10:	9.6	↓																																																					
Serie	95																																																						
Total	0																																																						
1:	9.8	←																																																					
2:	10.3x	↗																																																					
3:	9.2	→																																																					
4:	9.9	↑																																																					
5:	9.7	↘																																																					
Serie	46																																																						
Total	46																																																						
<p>30 Skott</p> 	<table style="width:100%; border-collapse: collapse;"> <tr><td>6:</td><td>10.1</td><td>→</td></tr> <tr><td>7:</td><td>10.5x</td><td>↓</td></tr> <tr><td>8:</td><td>10.1</td><td>←</td></tr> <tr><td>9:</td><td>9.9</td><td>↓</td></tr> <tr><td>10:</td><td>10.1</td><td>↓</td></tr> </table> <table style="width:100%; border-collapse: collapse;"> <tr><td>Serie</td><td style="text-align: right;">49</td></tr> <tr><td>Total</td><td style="text-align: right;">95</td></tr> </table>	6:	10.1	→	7:	10.5x	↓	8:	10.1	←	9:	9.9	↓	10:	10.1	↓	Serie	49	Total	95	<p>30 Skott</p>  <table style="width:100%; border-collapse: collapse;"> <tr><td>11:</td><td>10.8x</td><td>↘</td></tr> <tr><td>12:</td><td>10.5x</td><td>↗</td></tr> <tr><td>13:</td><td>10.4x</td><td>←</td></tr> <tr><td>14:</td><td>10.8x</td><td>↗</td></tr> <tr><td>15:</td><td>9.7</td><td>↗</td></tr> </table> <table style="width:100%; border-collapse: collapse;"> <tr><td>Serie</td><td style="text-align: right;">49</td></tr> <tr><td>Total</td><td style="text-align: right;">144</td></tr> </table>	11:	10.8x	↘	12:	10.5x	↗	13:	10.4x	←	14:	10.8x	↗	15:	9.7	↗	Serie	49	Total	144															
6:	10.1	→																																																					
7:	10.5x	↓																																																					
8:	10.1	←																																																					
9:	9.9	↓																																																					
10:	10.1	↓																																																					
Serie	49																																																						
Total	95																																																						
11:	10.8x	↘																																																					
12:	10.5x	↗																																																					
13:	10.4x	←																																																					
14:	10.8x	↗																																																					
15:	9.7	↗																																																					
Serie	49																																																						
Total	144																																																						
<p>30 Skott</p> 	<table style="width:100%; border-collapse: collapse;"> <tr><td>16:</td><td>10.4x</td><td>↗</td></tr> <tr><td>17:</td><td>10.8x</td><td>↘</td></tr> <tr><td>18:</td><td>8.9</td><td>←</td></tr> <tr><td>19:</td><td>10.3x</td><td>↘</td></tr> <tr><td>20:</td><td>9.8</td><td>←</td></tr> </table> <table style="width:100%; border-collapse: collapse;"> <tr><td>Serie</td><td style="text-align: right;">47</td></tr> <tr><td>Total</td><td style="text-align: right;">191</td></tr> </table>	16:	10.4x	↗	17:	10.8x	↘	18:	8.9	←	19:	10.3x	↘	20:	9.8	←	Serie	47	Total	191	<p>30 Skott</p>  <table style="width:100%; border-collapse: collapse;"> <tr><td>21:</td><td>9.0</td><td>←</td></tr> <tr><td>22:</td><td>10.1</td><td>↗</td></tr> <tr><td>23:</td><td>10.5x</td><td>→</td></tr> <tr><td>24:</td><td>10.1</td><td>↓</td></tr> <tr><td>25:</td><td>10.1</td><td>↓</td></tr> </table> <table style="width:100%; border-collapse: collapse;"> <tr><td>Serie</td><td style="text-align: right;">49</td></tr> <tr><td>Total</td><td style="text-align: right;">240</td></tr> </table>	21:	9.0	←	22:	10.1	↗	23:	10.5x	→	24:	10.1	↓	25:	10.1	↓	Serie	49	Total	240															
16:	10.4x	↗																																																					
17:	10.8x	↘																																																					
18:	8.9	←																																																					
19:	10.3x	↘																																																					
20:	9.8	←																																																					
Serie	47																																																						
Total	191																																																						
21:	9.0	←																																																					
22:	10.1	↗																																																					
23:	10.5x	→																																																					
24:	10.1	↓																																																					
25:	10.1	↓																																																					
Serie	49																																																						
Total	240																																																						
<p>30 Skott</p> 	<table style="width:100%; border-collapse: collapse;"> <tr><td>26:</td><td>10.2</td><td>↓</td></tr> <tr><td>27:</td><td>9.7</td><td>↑</td></tr> <tr><td>28:</td><td>10.0</td><td>←</td></tr> <tr><td>29:</td><td>10.4x</td><td>↗</td></tr> <tr><td>30:</td><td>9.7</td><td>←</td></tr> </table> <table style="width:100%; border-collapse: collapse;"> <tr><td>Serie</td><td style="text-align: right;">48</td></tr> <tr><td>Total</td><td style="text-align: right;">288</td></tr> </table>	26:	10.2	↓	27:	9.7	↑	28:	10.0	←	29:	10.4x	↗	30:	9.7	←	Serie	48	Total	288																																			
26:	10.2	↓																																																					
27:	9.7	↑																																																					
28:	10.0	←																																																					
29:	10.4x	↗																																																					
30:	9.7	←																																																					
Serie	48																																																						
Total	288																																																						

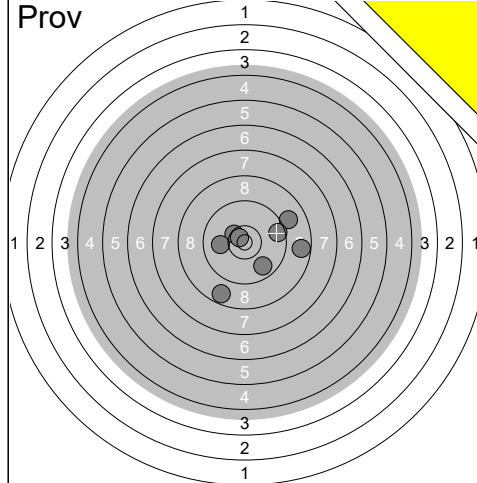

1:	9.0	→
2:	8.7	→
3:	8.7	↙
4:	10.4x	↗
5:	0.0	→
7:	9.6	→
8:	9.8	↘
9:	10.7x	↗
10:	10.0	←

Serie	73
Total	0

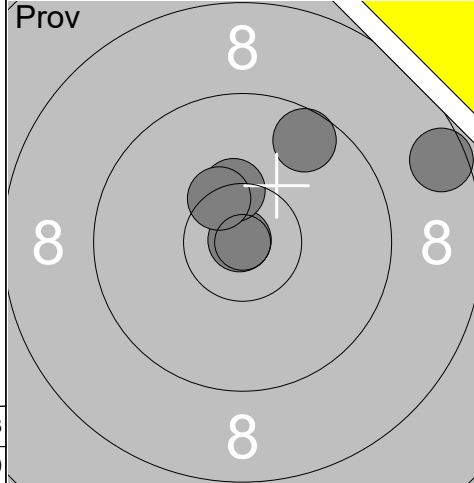

11:	9.6	↗
12:	10.9x	↖
13:	8.6	→
14:	10.4x	↑
15:	10.4x	↗

Serie	47
Total	0

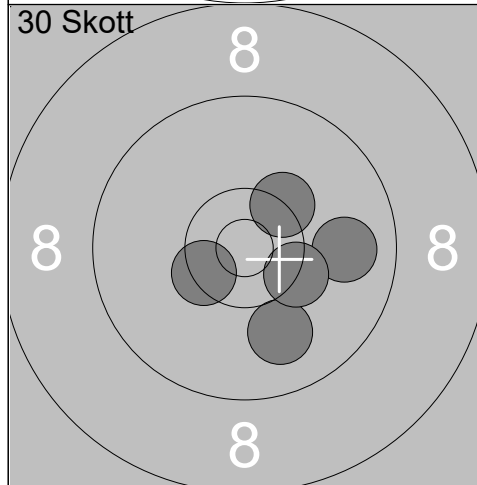

1:	9.9	→
2:	10.0	↘
3:	10.4x	↖
4:	10.3x	↘
5:	10.3x	↗

Serie	49
Total	49

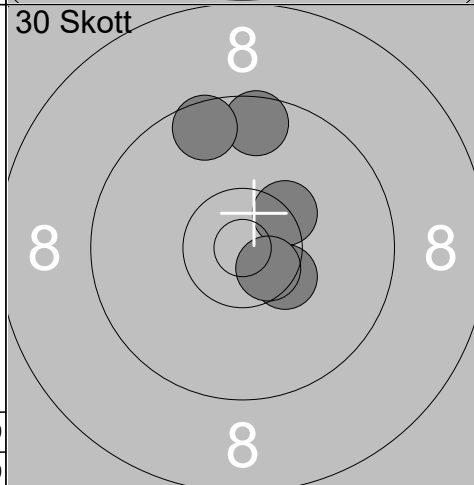

6:	10.4x	↗
7:	10.4x	↘
8:	10.6x	↘
9:	9.6	↑
10:	9.6	↑

Serie	48
Total	97

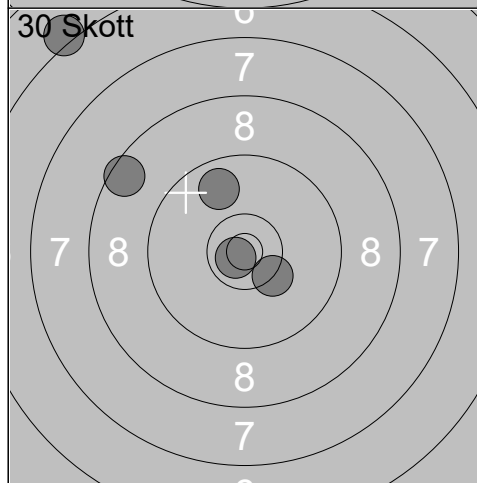

11:	10.3x	↘
12:	6.1	↗
13:	10.8x	↖
14:	8.5	↗
15:	9.8	↗

Serie	43
Total	140

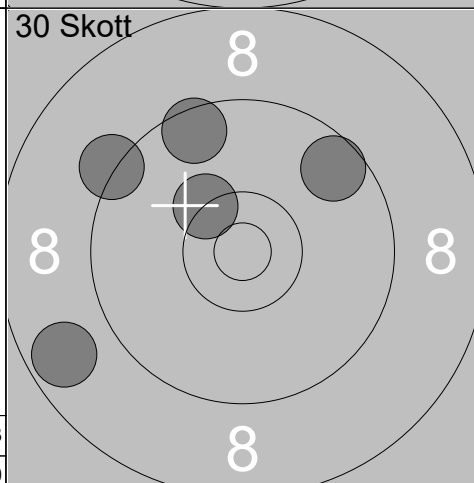

16:	9.5	↗
17:	9.6	↗
18:	8.7	↖
19:	9.3	↖
20:	10.3x	↗

Serie	45
Total	185

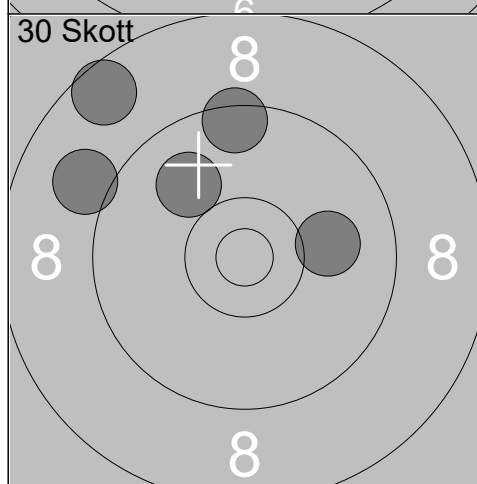

21:	9.0	↖
22:	9.5	↑
23:	10.0	→
24:	8.6	↗
25:	10.0	↗

Serie	46
Total	231

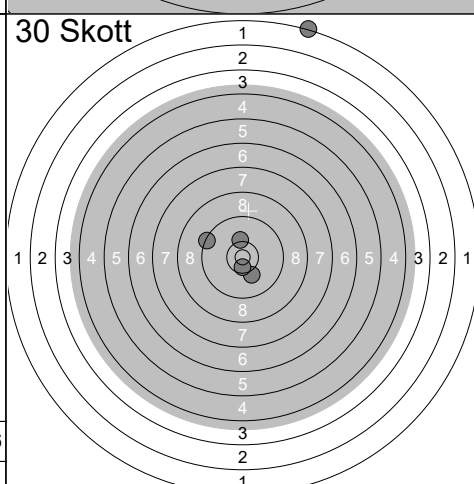

26:	10.2	↑
27:	10.1	↘
28:	10.5x	↘
29:	9.3	↖
30:	1.3	↑

Serie	40
Total	271

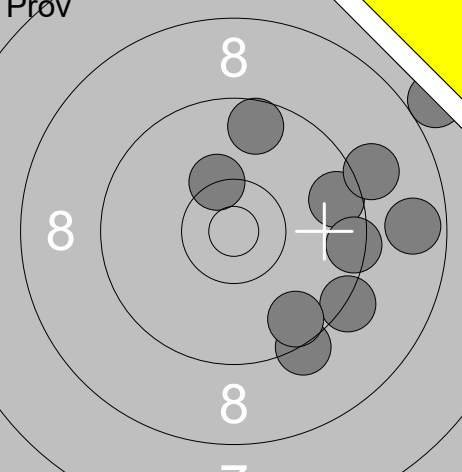
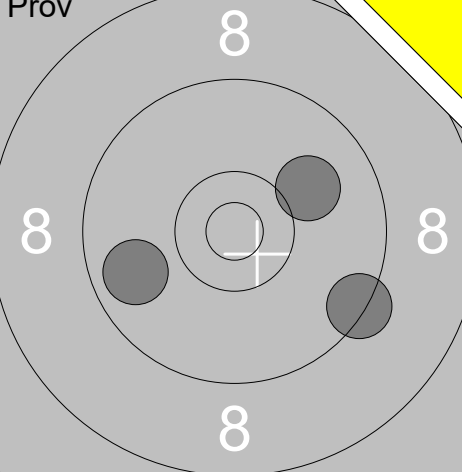
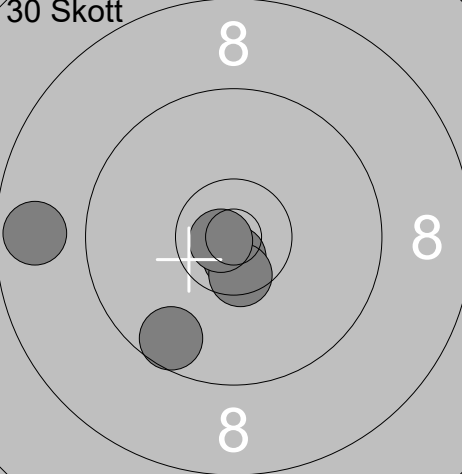
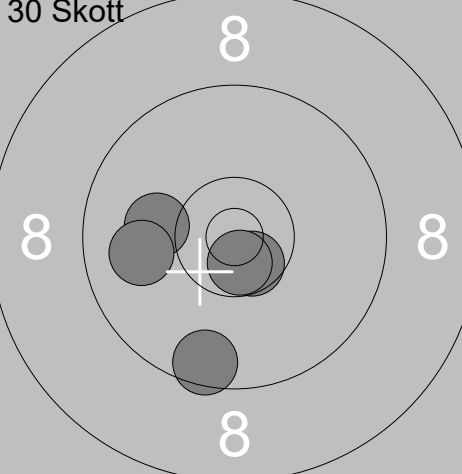
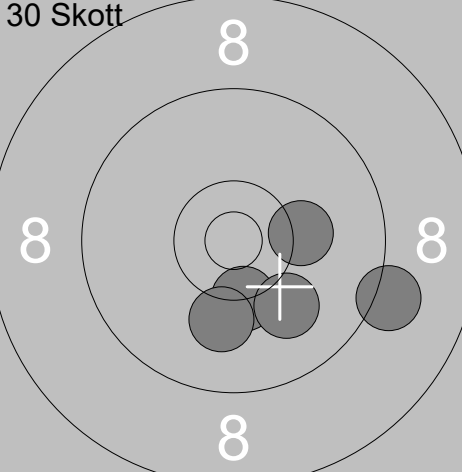
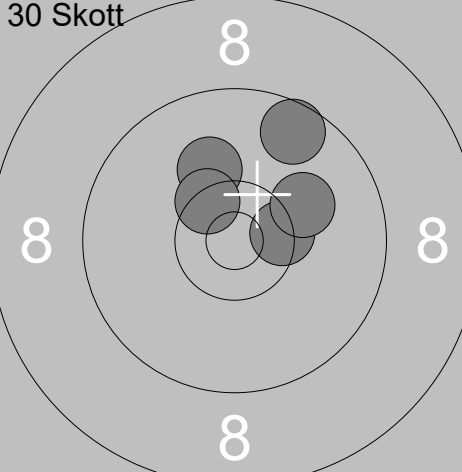
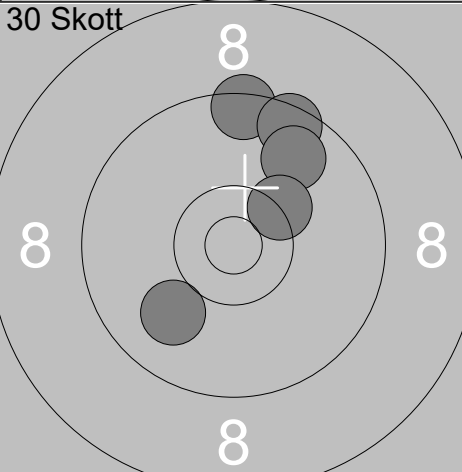
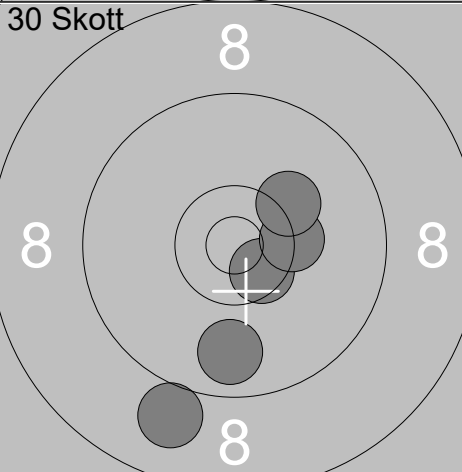
<p>Prov</p> 	<table border="1" style="width:100%; border-collapse: collapse;"> <tr><td>1:</td><td>8.0</td><td>↗</td></tr> <tr><td>2:</td><td>8.7</td><td>→</td></tr> <tr><td>3:</td><td>9.6</td><td>→</td></tr> <tr><td>4:</td><td>9.3</td><td>↘</td></tr> <tr><td>5:</td><td>9.4</td><td>→</td></tr> <tr><td>6:</td><td>9.3</td><td>↘</td></tr> <tr><td>7:</td><td>9.1</td><td>→</td></tr> <tr><td>8:</td><td>10.3x</td><td>↗</td></tr> <tr><td>9:</td><td>9.6</td><td>↗</td></tr> <tr><td>10:</td><td>9.6</td><td>↘</td></tr> <tr><td colspan="2">Serie</td><td style="text-align: right;">89</td></tr> <tr><td colspan="2">Total</td><td style="text-align: right;">0</td></tr> </table>	1:	8.0	↗	2:	8.7	→	3:	9.6	→	4:	9.3	↘	5:	9.4	→	6:	9.3	↘	7:	9.1	→	8:	10.3x	↗	9:	9.6	↗	10:	9.6	↘	Serie		89	Total		0	<p>Prov</p>  <table border="1" style="width:100%; border-collapse: collapse;"> <tr><td>11:</td><td>9.4</td><td>↘</td></tr> <tr><td>12:</td><td>9.8</td><td>↙</td></tr> <tr><td>13:</td><td>10.0</td><td>↗</td></tr> <tr><td colspan="2">Serie</td><td style="text-align: right;">28</td></tr> <tr><td colspan="2">Total</td><td style="text-align: right;">0</td></tr> </table>	11:	9.4	↘	12:	9.8	↙	13:	10.0	↗	Serie		28	Total		0
1:	8.0	↗																																																			
2:	8.7	→																																																			
3:	9.6	→																																																			
4:	9.3	↘																																																			
5:	9.4	→																																																			
6:	9.3	↘																																																			
7:	9.1	→																																																			
8:	10.3x	↗																																																			
9:	9.6	↗																																																			
10:	9.6	↘																																																			
Serie		89																																																			
Total		0																																																			
11:	9.4	↘																																																			
12:	9.8	↙																																																			
13:	10.0	↗																																																			
Serie		28																																																			
Total		0																																																			
<p>30 Skott</p>  <table border="1" style="width:100%; border-collapse: collapse;"> <tr><td>1:</td><td>9.6</td><td>↘</td></tr> <tr><td>2:</td><td>8.7</td><td>←</td></tr> <tr><td>3:</td><td>10.7x</td><td>↘</td></tr> <tr><td>4:</td><td>10.5x</td><td>↘</td></tr> <tr><td>5:</td><td>10.8x</td><td>←</td></tr> <tr><td colspan="2">Serie</td><td style="text-align: right;">47</td></tr> <tr><td colspan="2">Total</td><td style="text-align: right;">47</td></tr> </table>	1:	9.6	↘	2:	8.7	←	3:	10.7x	↘	4:	10.5x	↘	5:	10.8x	←	Serie		47	Total		47	<p>30 Skott</p>  <table border="1" style="width:100%; border-collapse: collapse;"> <tr><td>6:</td><td>10.1</td><td>←</td></tr> <tr><td>7:</td><td>10.6x</td><td>↘</td></tr> <tr><td>8:</td><td>10.7x</td><td>↘</td></tr> <tr><td>9:</td><td>9.6</td><td>↘</td></tr> <tr><td>10:</td><td>9.9</td><td>←</td></tr> <tr><td colspan="2">Serie</td><td style="text-align: right;">48</td></tr> <tr><td colspan="2">Total</td><td style="text-align: right;">95</td></tr> </table>	6:	10.1	←	7:	10.6x	↘	8:	10.7x	↘	9:	9.6	↘	10:	9.9	←	Serie		48	Total		95										
1:	9.6	↘																																																			
2:	8.7	←																																																			
3:	10.7x	↘																																																			
4:	10.5x	↘																																																			
5:	10.8x	←																																																			
Serie		47																																																			
Total		47																																																			
6:	10.1	←																																																			
7:	10.6x	↘																																																			
8:	10.7x	↘																																																			
9:	9.6	↘																																																			
10:	9.9	←																																																			
Serie		48																																																			
Total		95																																																			
<p>30 Skott</p>  <table border="1" style="width:100%; border-collapse: collapse;"> <tr><td>11:</td><td>9.2</td><td>↘</td></tr> <tr><td>12:</td><td>10.3x</td><td>↘</td></tr> <tr><td>13:</td><td>10.2</td><td>→</td></tr> <tr><td>14:</td><td>10.0</td><td>↘</td></tr> <tr><td>15:</td><td>10.1</td><td>↘</td></tr> <tr><td colspan="2">Serie</td><td style="text-align: right;">49</td></tr> <tr><td colspan="2">Total</td><td style="text-align: right;">144</td></tr> </table>	11:	9.2	↘	12:	10.3x	↘	13:	10.2	→	14:	10.0	↘	15:	10.1	↘	Serie		49	Total		144	<p>30 Skott</p>  <table border="1" style="width:100%; border-collapse: collapse;"> <tr><td>16:</td><td>10.1</td><td>↗</td></tr> <tr><td>17:</td><td>9.6</td><td>↗</td></tr> <tr><td>18:</td><td>10.4x</td><td>→</td></tr> <tr><td>19:</td><td>10.4x</td><td>↗</td></tr> <tr><td>20:</td><td>10.1</td><td>↗</td></tr> <tr><td colspan="2">Serie</td><td style="text-align: right;">49</td></tr> <tr><td colspan="2">Total</td><td style="text-align: right;">193</td></tr> </table>	16:	10.1	↗	17:	9.6	↗	18:	10.4x	→	19:	10.4x	↗	20:	10.1	↗	Serie		49	Total		193										
11:	9.2	↘																																																			
12:	10.3x	↘																																																			
13:	10.2	→																																																			
14:	10.0	↘																																																			
15:	10.1	↘																																																			
Serie		49																																																			
Total		144																																																			
16:	10.1	↗																																																			
17:	9.6	↗																																																			
18:	10.4x	→																																																			
19:	10.4x	↗																																																			
20:	10.1	↗																																																			
Serie		49																																																			
Total		193																																																			
<p>30 Skott</p>  <table border="1" style="width:100%; border-collapse: collapse;"> <tr><td>21:</td><td>9.4</td><td>↗</td></tr> <tr><td>22:</td><td>9.5</td><td>↗</td></tr> <tr><td>23:</td><td>9.8</td><td>↗</td></tr> <tr><td>24:</td><td>10.0</td><td>↙</td></tr> <tr><td>25:</td><td>10.3x</td><td>↗</td></tr> <tr><td colspan="2">Serie</td><td style="text-align: right;">47</td></tr> <tr><td colspan="2">Total</td><td style="text-align: right;">240</td></tr> </table>	21:	9.4	↗	22:	9.5	↗	23:	9.8	↗	24:	10.0	↙	25:	10.3x	↗	Serie		47	Total		240	<p>30 Skott</p>  <table border="1" style="width:100%; border-collapse: collapse;"> <tr><td>26:</td><td>10.5x</td><td>↘</td></tr> <tr><td>27:</td><td>10.3x</td><td>→</td></tr> <tr><td>28:</td><td>9.8</td><td>↘</td></tr> <tr><td>29:</td><td>10.2</td><td>↗</td></tr> <tr><td>30:</td><td>9.0</td><td>↘</td></tr> <tr><td colspan="2">Serie</td><td style="text-align: right;">48</td></tr> <tr><td colspan="2">Total</td><td style="text-align: right;">288</td></tr> </table>	26:	10.5x	↘	27:	10.3x	→	28:	9.8	↘	29:	10.2	↗	30:	9.0	↘	Serie		48	Total		288										
21:	9.4	↗																																																			
22:	9.5	↗																																																			
23:	9.8	↗																																																			
24:	10.0	↙																																																			
25:	10.3x	↗																																																			
Serie		47																																																			
Total		240																																																			
26:	10.5x	↘																																																			
27:	10.3x	→																																																			
28:	9.8	↘																																																			
29:	10.2	↗																																																			
30:	9.0	↘																																																			
Serie		48																																																			
Total		288																																																			

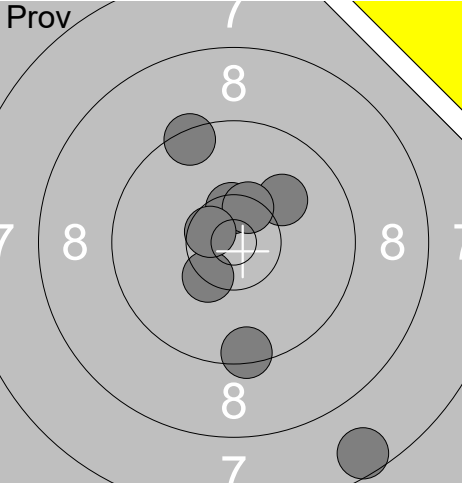
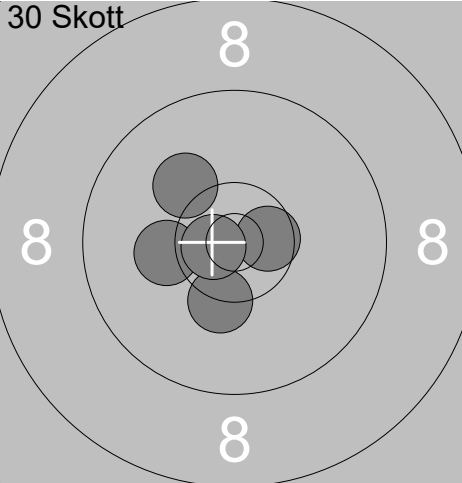
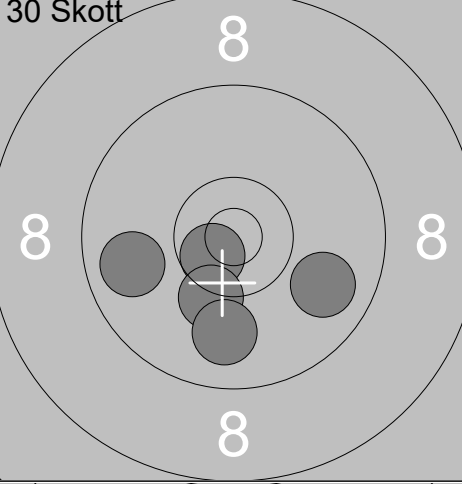
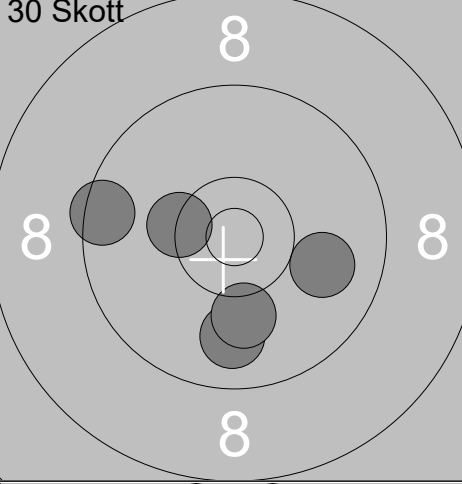
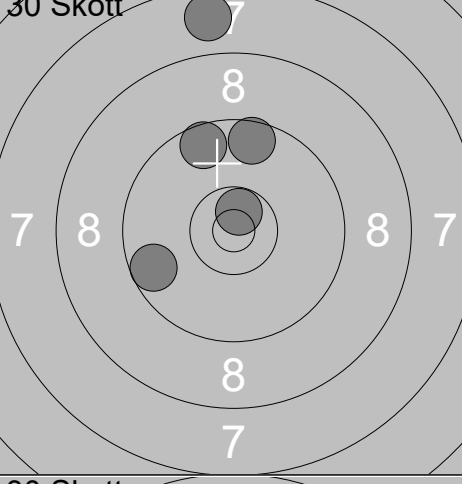
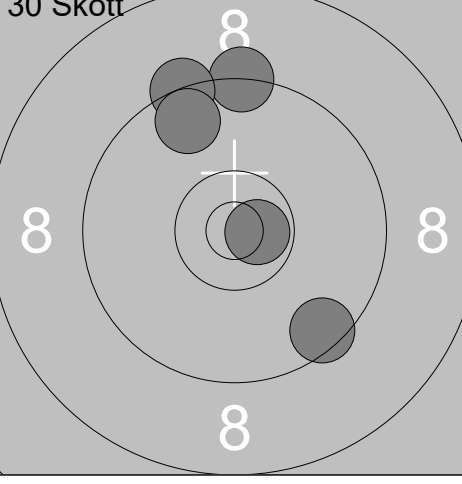
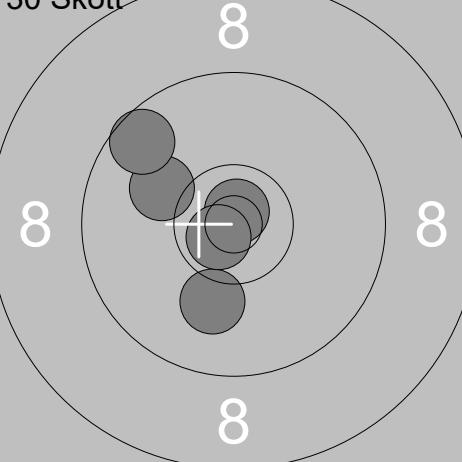
Skjutlag 2	Tavla 9	Håkan Lidman	
Ramselefors		Piteå	No
28.04.2019		Vindelnskottet 2019	Ramselefors SKF
Prov		1: 7.6 ↘ 2: 9.4 ↓ 3: 10.1 ↗ 4: 10.5x ↑ 5: 10.4x ↓ 6: 9.4 ↗ 7: 10.4x ↗ 8: 10.6x ↖	30 Skott 
	Serie 75	Total 0	1: 10.6x → 2: 10.2 ← 3: 10.1 ↗ 4: 10.3x ↓ 5: 10.7x ←
30 Skott		6: 10.6x ↖ 7: 9.8 ↗ 8: 10.2 ↓ 9: 9.9 ↓ 10: 9.8 ←	30 Skott 
	Serie 47	Total 97	11: 10.0 → 12: 9.9 ↓ 13: 9.5 ← 14: 10.3x ← 15: 10.1 ↓
30 Skott		16: 7.7 ↑ 17: 9.6 ← 18: 9.6 ↑ 19: 9.6 ↗ 20: 10.7x ↑	30 Skott 
	Serie 44	Total 189	21: 9.3 ↑ 22: 9.3 ↗ 23: 9.7 ↗ 24: 10.7x → 25: 9.5 ↓
30 Skott		26: 10.1 ↖ 27: 10.1 ↓ 28: 10.8x ↑ 29: 9.6 ↗ 30: 10.7x ↖	
	Serie 49	Total 284	

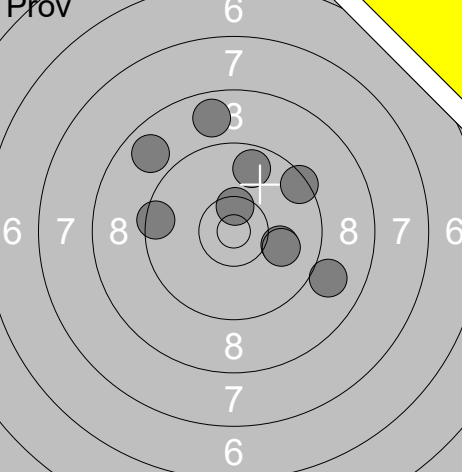
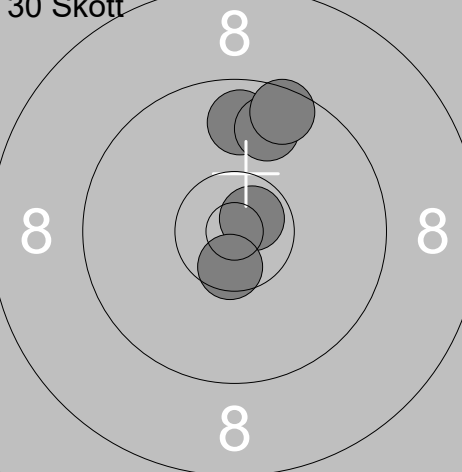
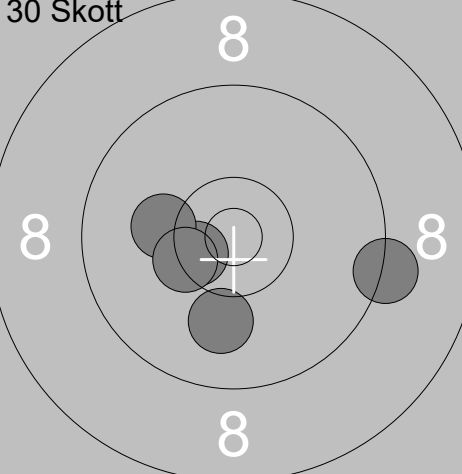
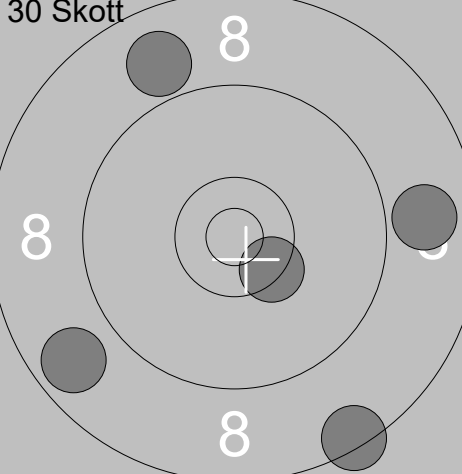
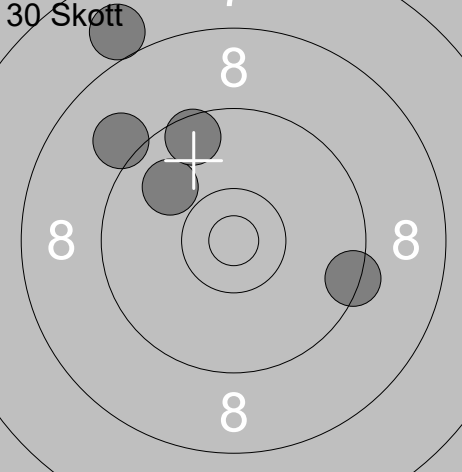
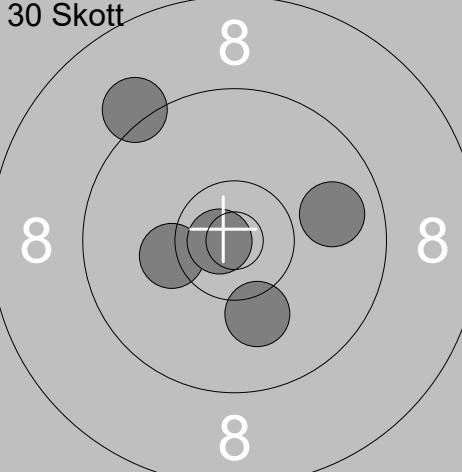
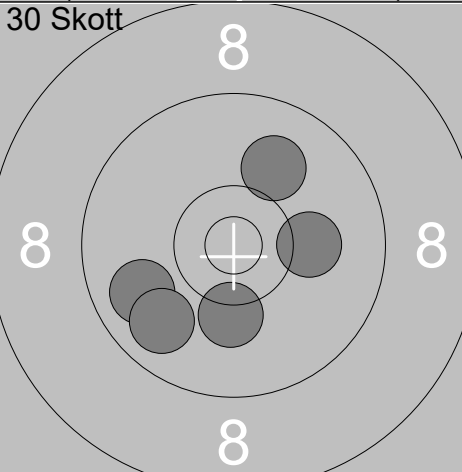
 <p>6 7 3 6 7 8 8 7 6 8 7 6</p>	<p>1: 5.5 ↗ 2: 9.4 ↗ 3: 9.0 ↘ 4: 8.8 ↑ 5: 9.5 ← 6: 9.7 ↑ 7: 10.5x ↑ 8: 10.0 ↘ 9: 8.8 ↗ 10: 10.0 ↘</p> <p>Serie 87 Total 0</p>	<p>30 Skott</p>  <p>8 8 8</p> <p>1: 9.8 ↑ 2: 9.8 ↑ 3: 9.6 ↑ 4: 10.7x ↗ 5: 10.6x ↓</p> <p>Serie 47 Total 47</p>
<p>30 Skott</p>  <p>8 8 8</p> <p>6: 10.5x ← 7: 10.2 ← 8: 10.4x ← 9: 10.0 ↓ 10: 9.3 →</p> <p>Serie 49 Total 96</p>	<p>30 Skott</p>  <p>8 8 8</p> <p>11: 10.4x ↘ 12: 8.7 ↙ 13: 8.9 → 14: 8.4 ↘ 15: 8.9 ↗</p> <p>Serie 42 Total 138</p>	
<p>30 Skott</p>  <p>8 8 8</p> <p>16: 9.9 ↗ 17: 8.0 ↗ 18: 9.4 ↘ 19: 9.1 ↗ 20: 9.6 ↗</p> <p>Serie 44 Total 182</p>	<p>30 Skott</p>  <p>8 8 8</p> <p>21: 9.2 ↗ 22: 9.9 → 23: 10.1 ↓ 24: 10.2 ← 25: 10.8x ←</p> <p>Serie 48 Total 230</p>	
<p>30 Skott</p>  <p>8 8 8</p> <p>26: 9.8 ← 27: 10.0 ↑ 28: 10.1 → 29: 9.8 ↙ 30: 10.2 ↓</p> <p>Serie 48 Total 278</p>		

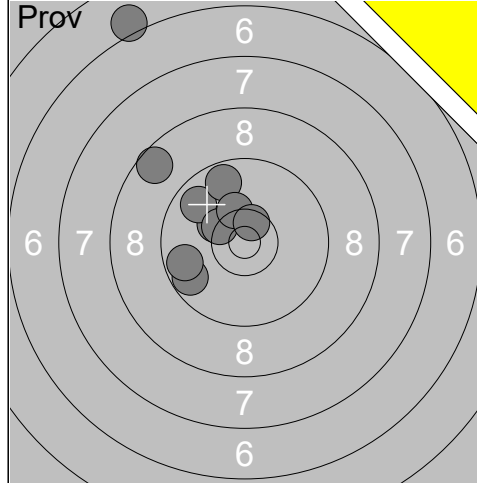

1:	6.1	↗
2:	8.6	↗
3:	10.3	↗
4:	9.8	↗
5:	10.4x	↗
6:	9.7	↗
7:	9.7	↖
8:	10.3x	↗
9:	9.7	↖
10:	10.5x	↗

Serie	90
Total	0

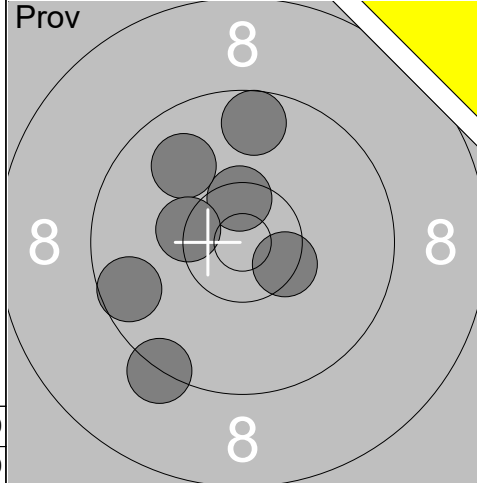

11:	9.3	↘
12:	9.6	↗
13:	10.5x	↗
14:	9.9	↗
15:	10.3x	↖
16:	10.4x	↘
17:	9.6	↖

Serie	66
Total	0

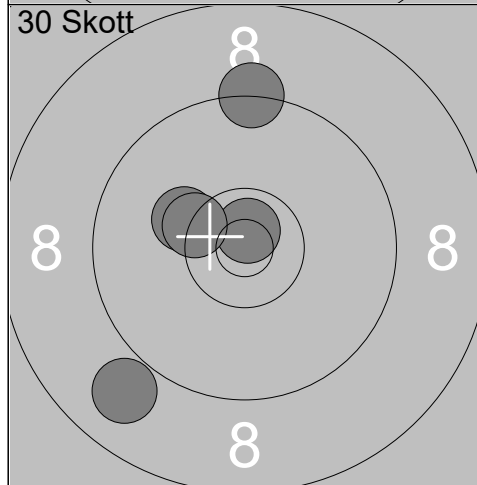

1:	9.3	↗
2:	10.2	↖
3:	10.8x	↗
4:	10.4x	↖
5:	8.9	↘

Serie	47
Total	47

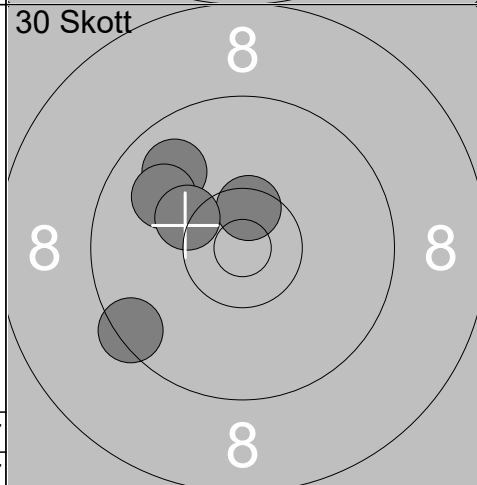

6:	9.4	↖
7:	9.8	↗
8:	9.9	↗
9:	10.5x	↗
10:	10.3	↖

Serie	47
Total	94

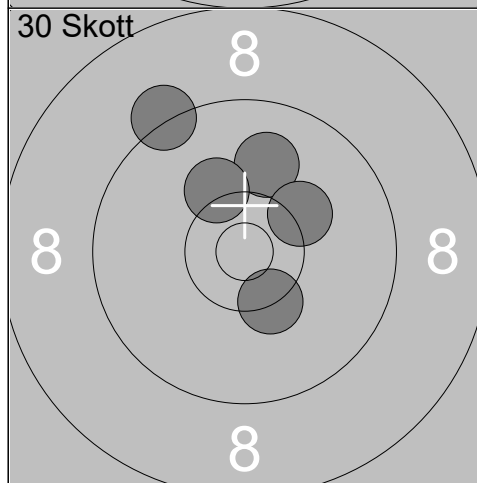

11:	10.0	↗
12:	9.3	↗
13:	10.3x	↘
14:	10.2	↗
15:	10.2	↗

Serie	49
Total	143

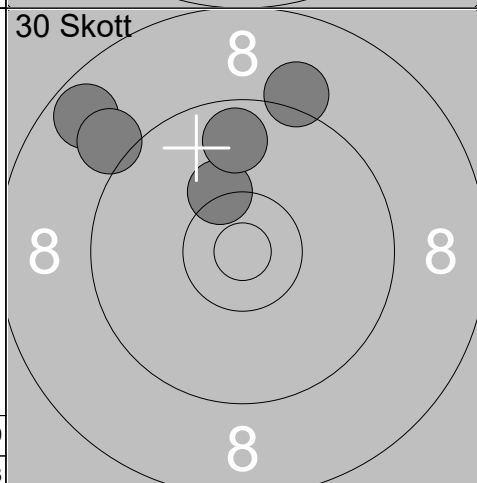

16:	10.3	↗
17:	8.7	↖
18:	9.1	↗
19:	9.1	↗
20:	9.7	↗

Serie	45
Total	188

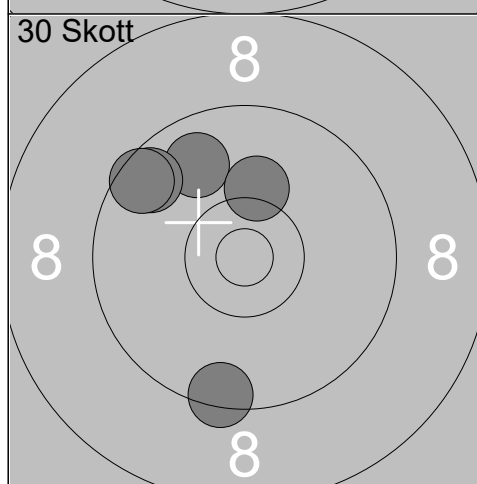

21:	9.8	↗
22:	9.6	↗
23:	9.4	↘
24:	9.6	↗
25:	10.2	↗

Serie	46
Total	234

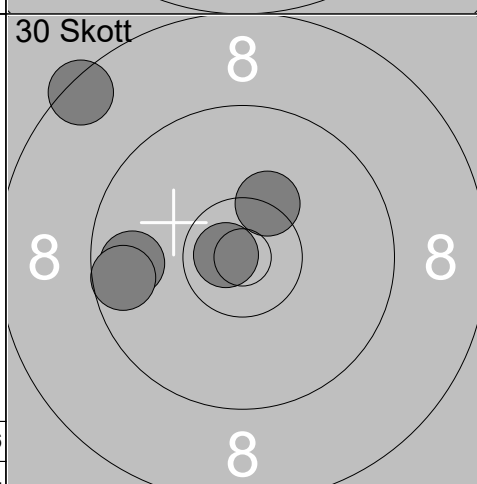

26:	9.7	↖
27:	10.8x	↖
28:	10.3x	↗
29:	8.4	↖
30:	9.6	↖

Serie	46
Total	280

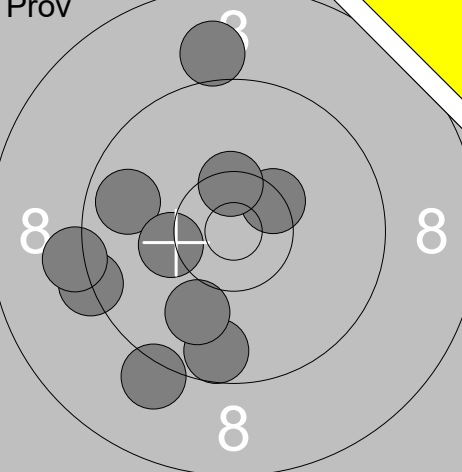
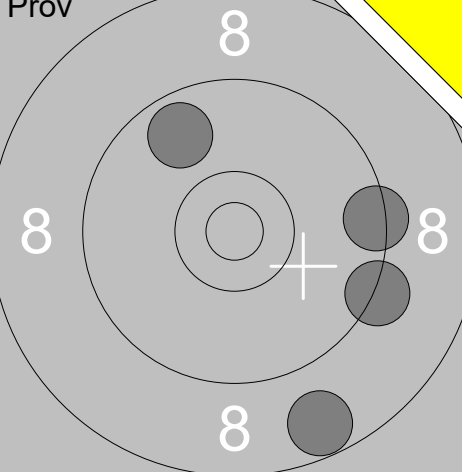
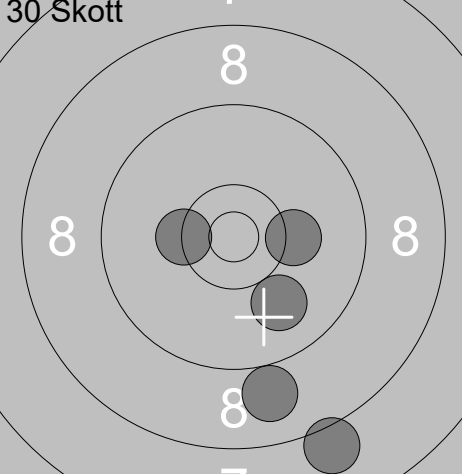
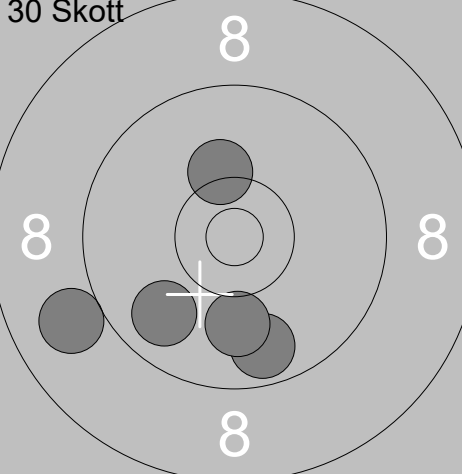
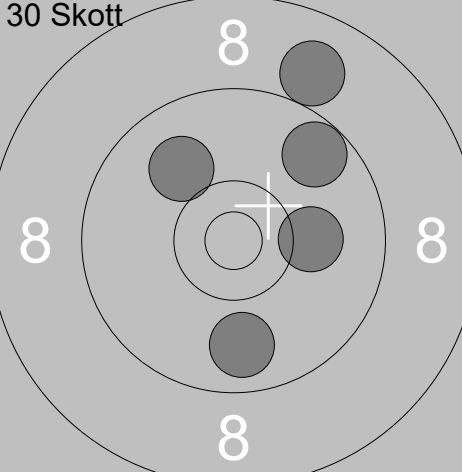
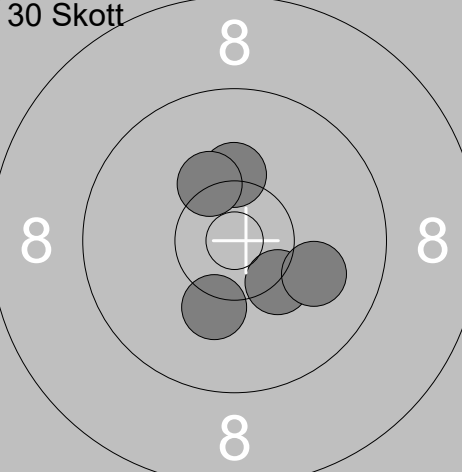
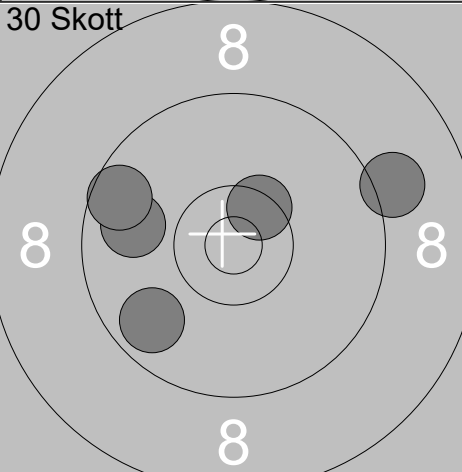
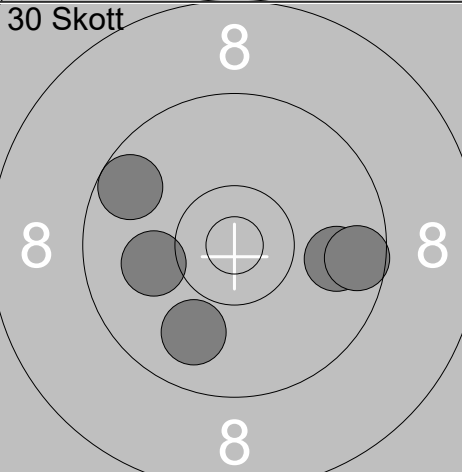
<p>Prov</p> 	<table border="1" style="width:100%; border-collapse: collapse;"> <tr><td>1:</td><td>9.0</td><td>↑</td></tr> <tr><td>2:</td><td>10.4x</td><td>↗</td></tr> <tr><td>3:</td><td>9.2</td><td>↘</td></tr> <tr><td>4:</td><td>9.6</td><td>↘</td></tr> <tr><td>5:</td><td>9.3</td><td>↙</td></tr> <tr><td>6:</td><td>10.0</td><td>↘</td></tr> <tr><td>7:</td><td>9.2</td><td>↙</td></tr> <tr><td>8:</td><td>9.8</td><td>↙</td></tr> <tr><td>9:</td><td>10.3</td><td>↙</td></tr> <tr><td>10:</td><td>10.4x</td><td>↑</td></tr> <tr><td colspan="2">Serie</td><td>94</td></tr> <tr><td colspan="2">Total</td><td>0</td></tr> </table>	1:	9.0	↑	2:	10.4x	↗	3:	9.2	↘	4:	9.6	↘	5:	9.3	↙	6:	10.0	↘	7:	9.2	↙	8:	9.8	↙	9:	10.3	↙	10:	10.4x	↑	Serie		94	Total		0	<p>Prov</p>  <table border="1" style="width:100%; border-collapse: collapse;"> <tr><td>11:</td><td>9.7</td><td>↗</td></tr> <tr><td>12:</td><td>8.7</td><td>↘</td></tr> <tr><td>13:</td><td>9.3</td><td>↘</td></tr> <tr><td>14:</td><td>9.4</td><td>→</td></tr> <tr><td colspan="2">Serie</td><td>35</td></tr> <tr><td colspan="2">Total</td><td>0</td></tr> </table>	11:	9.7	↗	12:	8.7	↘	13:	9.3	↘	14:	9.4	→	Serie		35	Total		0
1:	9.0	↑																																																						
2:	10.4x	↗																																																						
3:	9.2	↘																																																						
4:	9.6	↘																																																						
5:	9.3	↙																																																						
6:	10.0	↘																																																						
7:	9.2	↙																																																						
8:	9.8	↙																																																						
9:	10.3	↙																																																						
10:	10.4x	↑																																																						
Serie		94																																																						
Total		0																																																						
11:	9.7	↗																																																						
12:	8.7	↘																																																						
13:	9.3	↘																																																						
14:	9.4	→																																																						
Serie		35																																																						
Total		0																																																						
<p>30 Skott</p>  <table border="1" style="width:100%; border-collapse: collapse;"> <tr><td>1:</td><td>9.9</td><td>↘</td></tr> <tr><td>2:</td><td>10.2</td><td>→</td></tr> <tr><td>3:</td><td>10.3x</td><td>↙</td></tr> <tr><td>4:</td><td>8.9</td><td>↘</td></tr> <tr><td>5:</td><td>8.1</td><td>↘</td></tr> <tr><td colspan="2">Serie</td><td>45</td></tr> <tr><td colspan="2">Total</td><td>45</td></tr> </table>	1:	9.9	↘	2:	10.2	→	3:	10.3x	↙	4:	8.9	↘	5:	8.1	↘	Serie		45	Total		45	<p>30 Skott</p>  <table border="1" style="width:100%; border-collapse: collapse;"> <tr><td>6:</td><td>9.0</td><td>↙</td></tr> <tr><td>7:</td><td>9.7</td><td>↘</td></tr> <tr><td>8:</td><td>9.8</td><td>↙</td></tr> <tr><td>9:</td><td>10.0</td><td>↘</td></tr> <tr><td>10:</td><td>10.2</td><td>↑</td></tr> <tr><td colspan="2">Serie</td><td>47</td></tr> <tr><td colspan="2">Total</td><td>92</td></tr> </table>	6:	9.0	↙	7:	9.7	↘	8:	9.8	↙	9:	10.0	↘	10:	10.2	↑	Serie		47	Total		92													
1:	9.9	↘																																																						
2:	10.2	→																																																						
3:	10.3x	↙																																																						
4:	8.9	↘																																																						
5:	8.1	↘																																																						
Serie		45																																																						
Total		45																																																						
6:	9.0	↙																																																						
7:	9.7	↘																																																						
8:	9.8	↙																																																						
9:	10.0	↘																																																						
10:	10.2	↑																																																						
Serie		47																																																						
Total		92																																																						
<p>30 Skott</p>  <table border="1" style="width:100%; border-collapse: collapse;"> <tr><td>11:</td><td>9.8</td><td>↘</td></tr> <tr><td>12:</td><td>8.9</td><td>↑</td></tr> <tr><td>13:</td><td>10.0</td><td>↗</td></tr> <tr><td>14:</td><td>9.7</td><td>↗</td></tr> <tr><td>15:</td><td>10.1</td><td>→</td></tr> <tr><td colspan="2">Serie</td><td>46</td></tr> <tr><td colspan="2">Total</td><td>138</td></tr> </table>	11:	9.8	↘	12:	8.9	↑	13:	10.0	↗	14:	9.7	↗	15:	10.1	→	Serie		46	Total		138	<p>30 Skott</p>  <table border="1" style="width:100%; border-collapse: collapse;"> <tr><td>16:</td><td>10.3x</td><td>↘</td></tr> <tr><td>17:</td><td>10.0</td><td>→</td></tr> <tr><td>18:</td><td>10.2</td><td>↑</td></tr> <tr><td>19:</td><td>10.3</td><td>↗</td></tr> <tr><td>20:</td><td>10.2</td><td>↘</td></tr> <tr><td colspan="2">Serie</td><td>50</td></tr> <tr><td colspan="2">Total</td><td>188</td></tr> </table>	16:	10.3x	↘	17:	10.0	→	18:	10.2	↑	19:	10.3	↗	20:	10.2	↘	Serie		50	Total		188													
11:	9.8	↘																																																						
12:	8.9	↑																																																						
13:	10.0	↗																																																						
14:	9.7	↗																																																						
15:	10.1	→																																																						
Serie		46																																																						
Total		138																																																						
16:	10.3x	↘																																																						
17:	10.0	→																																																						
18:	10.2	↑																																																						
19:	10.3	↗																																																						
20:	10.2	↘																																																						
Serie		50																																																						
Total		188																																																						
<p>30 Skott</p>  <table border="1" style="width:100%; border-collapse: collapse;"> <tr><td>21:</td><td>10.5x</td><td>↗</td></tr> <tr><td>22:</td><td>9.8</td><td>↘</td></tr> <tr><td>23:</td><td>9.8</td><td>↙</td></tr> <tr><td>24:</td><td>9.6</td><td>↙</td></tr> <tr><td>25:</td><td>9.1</td><td>→</td></tr> <tr><td colspan="2">Serie</td><td>46</td></tr> <tr><td colspan="2">Total</td><td>234</td></tr> </table>	21:	10.5x	↗	22:	9.8	↘	23:	9.8	↙	24:	9.6	↙	25:	9.1	→	Serie		46	Total		234	<p>30 Skott</p>  <table border="1" style="width:100%; border-collapse: collapse;"> <tr><td>26:</td><td>9.8</td><td>→</td></tr> <tr><td>27:</td><td>9.6</td><td>→</td></tr> <tr><td>28:</td><td>9.7</td><td>↗</td></tr> <tr><td>29:</td><td>10.0</td><td>↙</td></tr> <tr><td>30:</td><td>9.9</td><td>↘</td></tr> <tr><td colspan="2">Serie</td><td>46</td></tr> <tr><td colspan="2">Total</td><td>280</td></tr> </table>	26:	9.8	→	27:	9.6	→	28:	9.7	↗	29:	10.0	↙	30:	9.9	↘	Serie		46	Total		280													
21:	10.5x	↗																																																						
22:	9.8	↘																																																						
23:	9.8	↙																																																						
24:	9.6	↙																																																						
25:	9.1	→																																																						
Serie		46																																																						
Total		234																																																						
26:	9.8	→																																																						
27:	9.6	→																																																						
28:	9.7	↗																																																						
29:	10.0	↙																																																						
30:	9.9	↘																																																						
Serie		46																																																						
Total		280																																																						

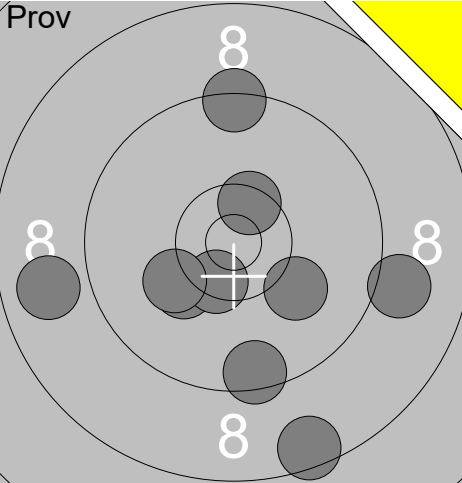
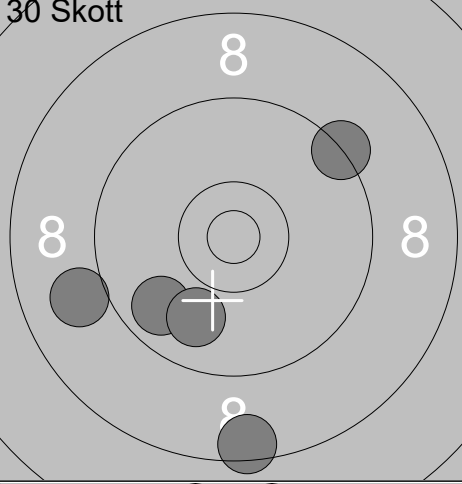
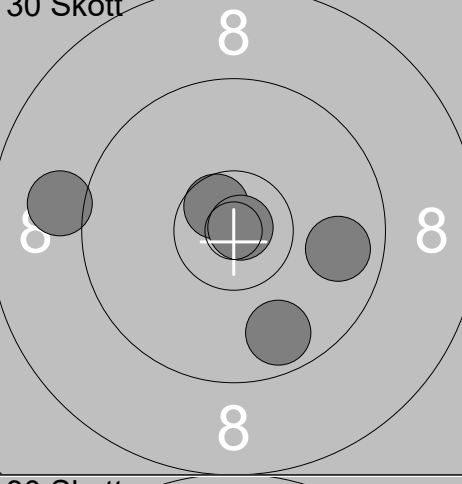
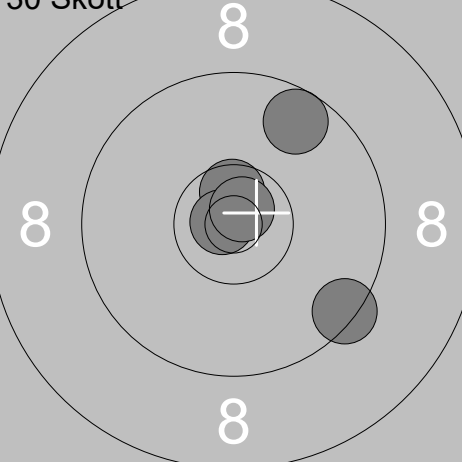
Skjutlag	Tavla	Helena Perkiömäki	
2	13	Ramselefors	Umeå
28.04.2019	Vindelnskottet 2019	Ramselefors SKF	
Prov		1: 9.4 ↑ 2: 8.5 ↓ 3: 9.0 → 4: 10.2 ↓ 5: 10.5x ↑ 6: 10.1 ↓ 7: 10.5x ↓ 8: 8.8 ← 9: 10.2 ← 10: 9.5 ↓	11: 9.5 ↓ 12: 9.4 ↓ 13: 10.2 ↗ 14: 9.7 ←
	Serie 93 Total 0		Serie 37 Total 0
30 Skott		1: 9.8 ↙ 2: 8.5 ↓ 3: 9.9 ↓ 4: 9.3 ↗ 5: 9.0 ←	6: 9.9 ↙ 7: 10.0 ← 8: 10.8x ← 9: 9.4 ↙ 10: 8.9 ↗
	Serie 44 Total 44		Serie 46 Total 90
30 Skott		11: 9.7 ↓ 12: 10.6x ↗ 13: 10.9x ↗ 14: 9.0 ← 15: 9.8 →	16: 10.1 ↗ 17: 9.8 → 18: 10.6x ← 19: 10.4x ↓ 20: 10.6x ↗
	Serie 47 Total 137		Serie 49 Total 186
30 Skott		21: 9.4 ↘ 22: 9.6 ↗ 23: 10.6x ↑ 24: 10.8x ← 25: 10.8x ↗	26: 10.1 ↙ 27: 9.0 ↗ 28: 10.2 ↗ 29: 10.4x ↗ 30: 9.9 →
	Serie 48 Total 234		Serie 48 Total 282

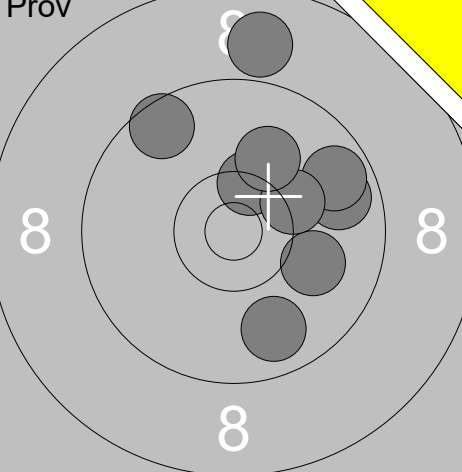
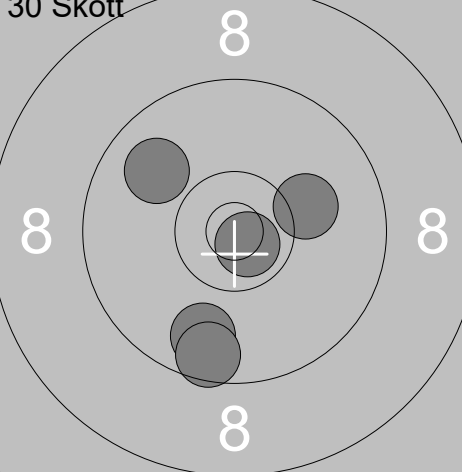
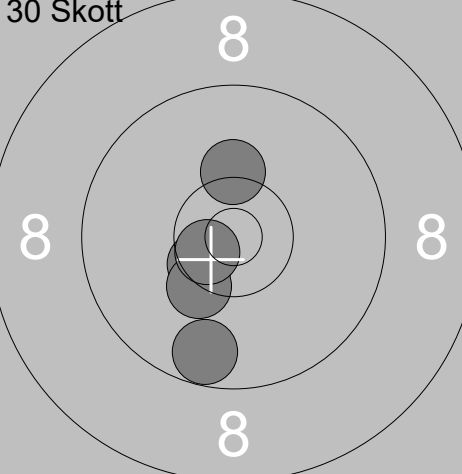
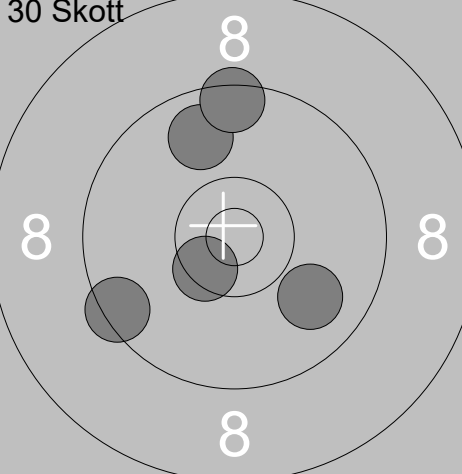
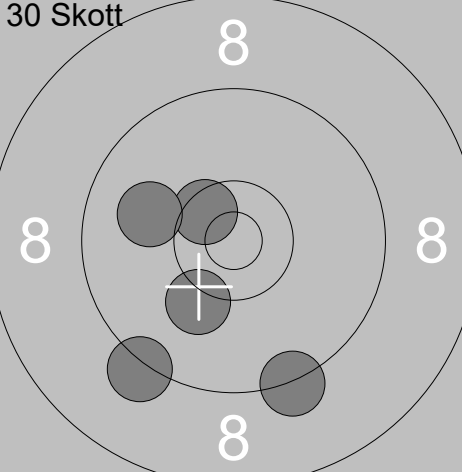
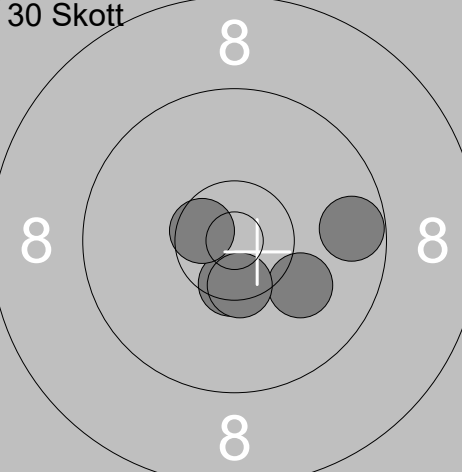
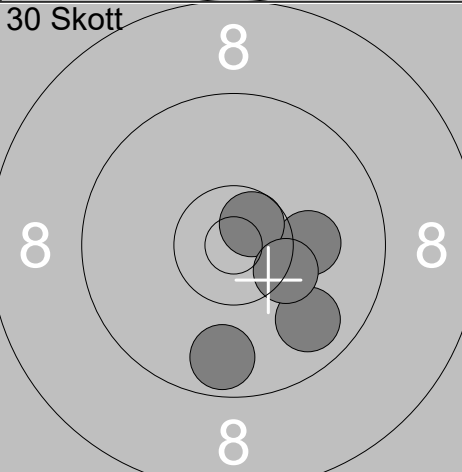
<p>Prov</p>  <p style="text-align: center;">8</p>	<p>1: 8.9 ↑</p> <p>2: 10.4x ↑</p> <p>3: 9.8 ↓</p> <p>4: 10.0 →</p> <p>5: 9.6 ↗</p> <p>6: 9.8 →</p> <p>7: 9.7 ↗</p> <p>8: 10.2 ↗</p> <p>9: 10.1 ↑</p> <hr/> <p>Serie 84</p> <p>Total 0</p>	<p>30 Skott</p>  <p style="text-align: center;">8</p>	<p>1: 9.8 ↓</p> <p>2: 9.9 ↖</p> <p>3: 10.8x ↓</p> <p>4: 10.1 →</p> <p>5: 9.6 ↓</p> <hr/> <p>Serie 47</p> <p>Total 47</p>
<p>30 Skott</p>  <p style="text-align: center;">8</p>	<p>6: 10.5x ↙</p> <p>7: 10.3x ↙</p> <p>8: 10.2 ↑</p> <p>9: 9.7 ↓</p> <p>10: 10.6x ↙</p> <hr/> <p>Serie 49</p> <p>Total 96</p>	<p>30 Skott</p>  <p style="text-align: center;">8</p>	<p>11: 9.8 ↑</p> <p>12: 10.5x ↙</p> <p>13: 9.9 ↘</p> <p>14: 9.5 ↙</p> <p>15: 9.5 ↑</p> <hr/> <p>Serie 46</p> <p>Total 142</p>
<p>30 Skott</p>  <p style="text-align: center;">8</p>	<p>16: 10.5x ↗</p> <p>17: 10.0 ↖</p> <p>18: 10.2 ↙</p> <p>19: 9.2 ↙</p> <p>20: 9.3 ↓</p> <hr/> <p>Serie 48</p> <p>Total 190</p>	<p>30 Skott</p>  <p style="text-align: center;">8</p>	<p>21: 10.5x ↓</p> <p>22: 10.6x ↖</p> <p>23: 10.1 ↘</p> <p>24: 10.5x ↓</p> <p>25: 9.7 →</p> <hr/> <p>Serie 49</p> <p>Total 239</p>
<p>30 Skott</p>  <p style="text-align: center;">8</p>	<p>26: 9.7 ↓</p> <p>27: 9.8 ↓</p> <p>28: 10.1 →</p> <p>29: 10.6x ↗</p> <p>30: 10.3x ↘</p> <hr/> <p>Serie 48</p> <p>Total 287</p>		

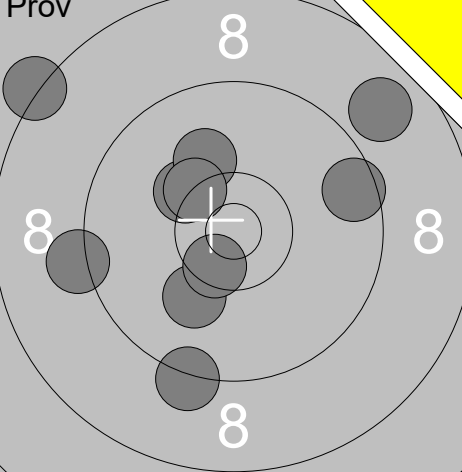
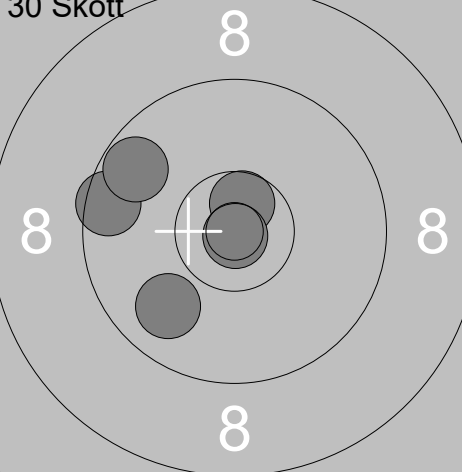
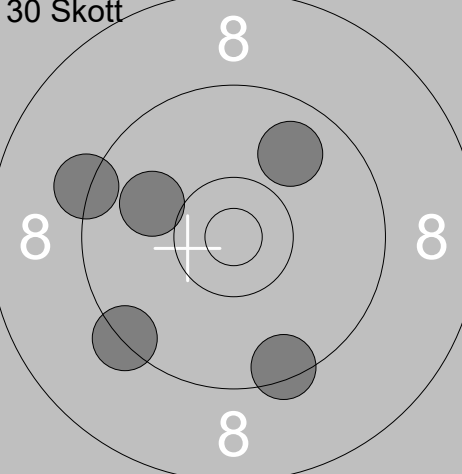
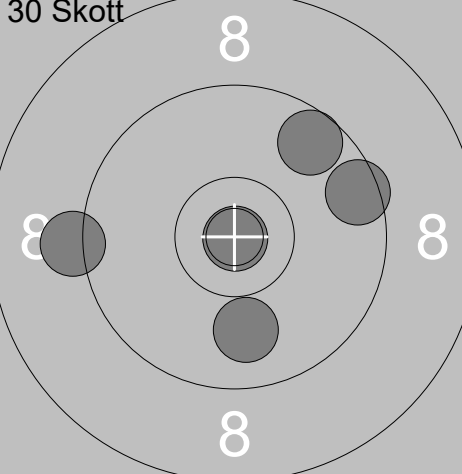
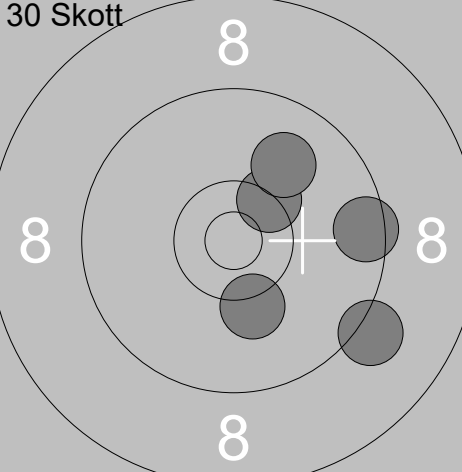
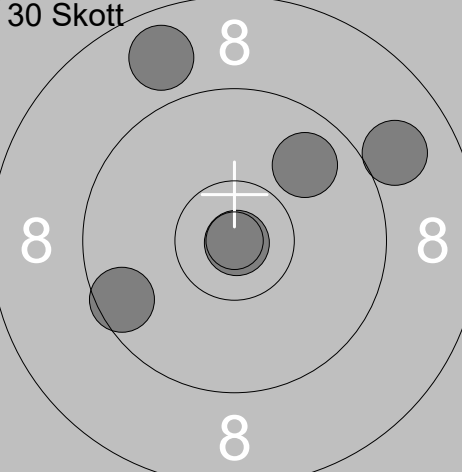
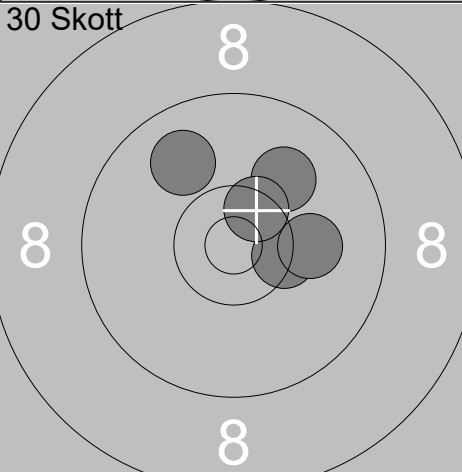
 <p style="text-align: center;">Prov</p>	<table style="width:100%; border-collapse: collapse;"> <tr><td>1:</td><td>8.8</td><td>↗</td></tr> <tr><td>2:</td><td>9.2</td><td>↓</td></tr> <tr><td>3:</td><td>9.5</td><td>→</td></tr> <tr><td>4:</td><td>10.1</td><td>↓</td></tr> <tr><td>5:</td><td>10.3</td><td>↗</td></tr> <tr><td>6:</td><td>9.2</td><td>←</td></tr> <tr><td>7:</td><td>10.5x</td><td>↓</td></tr> <tr><td>8:</td><td>10.1</td><td>↗</td></tr> <tr><td>9:</td><td>8.2</td><td>↗</td></tr> <tr><td>10:</td><td>10.3x</td><td>↗</td></tr> <tr><td colspan="2">Serie</td><td style="text-align: right;">93</td></tr> <tr><td colspan="2">Total</td><td style="text-align: right;">0</td></tr> </table>	1:	8.8	↗	2:	9.2	↓	3:	9.5	→	4:	10.1	↓	5:	10.3	↗	6:	9.2	←	7:	10.5x	↓	8:	10.1	↗	9:	8.2	↗	10:	10.3x	↗	Serie		93	Total		0	 <p style="text-align: center;">30 Skott</p> <table style="width:100%; border-collapse: collapse;"> <tr><td>1:</td><td>9.5</td><td>←</td></tr> <tr><td>2:</td><td>9.7</td><td>↖</td></tr> <tr><td>3:</td><td>9.9</td><td>↓</td></tr> <tr><td>4:</td><td>10.6x</td><td>↑</td></tr> <tr><td>5:</td><td>10.9x</td><td>↓</td></tr> <tr><td colspan="2">Serie</td><td style="text-align: right;">47</td></tr> <tr><td colspan="2">Total</td><td style="text-align: right;">47</td></tr> </table>	1:	9.5	←	2:	9.7	↖	3:	9.9	↓	4:	10.6x	↑	5:	10.9x	↓	Serie		47	Total		47
1:	8.8	↗																																																									
2:	9.2	↓																																																									
3:	9.5	→																																																									
4:	10.1	↓																																																									
5:	10.3	↗																																																									
6:	9.2	←																																																									
7:	10.5x	↓																																																									
8:	10.1	↗																																																									
9:	8.2	↗																																																									
10:	10.3x	↗																																																									
Serie		93																																																									
Total		0																																																									
1:	9.5	←																																																									
2:	9.7	↖																																																									
3:	9.9	↓																																																									
4:	10.6x	↑																																																									
5:	10.9x	↓																																																									
Serie		47																																																									
Total		47																																																									
 <p style="text-align: center;">30 Skott</p>	<table style="width:100%; border-collapse: collapse;"> <tr><td>6:</td><td>9.3</td><td>←</td></tr> <tr><td>7:</td><td>9.9</td><td>↗</td></tr> <tr><td>8:</td><td>10.0</td><td>←</td></tr> <tr><td>9:</td><td>9.4</td><td>↓</td></tr> <tr><td>10:</td><td>9.3</td><td>↓</td></tr> <tr><td colspan="2">Serie</td><td style="text-align: right;">46</td></tr> <tr><td colspan="2">Total</td><td style="text-align: right;">93</td></tr> </table>	6:	9.3	←	7:	9.9	↗	8:	10.0	←	9:	9.4	↓	10:	9.3	↓	Serie		46	Total		93	 <p style="text-align: center;">30 Skott</p> <table style="width:100%; border-collapse: collapse;"> <tr><td>11:</td><td>10.9x</td><td>↓</td></tr> <tr><td>12:</td><td>9.2</td><td>←</td></tr> <tr><td>13:</td><td>9.5</td><td>→</td></tr> <tr><td>14:</td><td>9.6</td><td>↗</td></tr> <tr><td>15:</td><td>9.9</td><td>↓</td></tr> <tr><td colspan="2">Serie</td><td style="text-align: right;">46</td></tr> <tr><td colspan="2">Total</td><td style="text-align: right;">139</td></tr> </table>	11:	10.9x	↓	12:	9.2	←	13:	9.5	→	14:	9.6	↗	15:	9.9	↓	Serie		46	Total		139															
6:	9.3	←																																																									
7:	9.9	↗																																																									
8:	10.0	←																																																									
9:	9.4	↓																																																									
10:	9.3	↓																																																									
Serie		46																																																									
Total		93																																																									
11:	10.9x	↓																																																									
12:	9.2	←																																																									
13:	9.5	→																																																									
14:	9.6	↗																																																									
15:	9.9	↓																																																									
Serie		46																																																									
Total		139																																																									
 <p style="text-align: center;">30 Skott</p>	<table style="width:100%; border-collapse: collapse;"> <tr><td>16:</td><td>9.5</td><td>→</td></tr> <tr><td>17:</td><td>10.4x</td><td>↗</td></tr> <tr><td>18:</td><td>10.2</td><td>↓</td></tr> <tr><td>19:</td><td>10.0</td><td>↗</td></tr> <tr><td>20:</td><td>9.2</td><td>↓</td></tr> <tr><td colspan="2">Serie</td><td style="text-align: right;">48</td></tr> <tr><td colspan="2">Total</td><td style="text-align: right;">187</td></tr> </table>	16:	9.5	→	17:	10.4x	↗	18:	10.2	↓	19:	10.0	↗	20:	9.2	↓	Serie		48	Total		187	 <p style="text-align: center;">30 Skott</p> <table style="width:100%; border-collapse: collapse;"> <tr><td>21:</td><td>9.6</td><td>←</td></tr> <tr><td>22:</td><td>9.0</td><td>↗</td></tr> <tr><td>23:</td><td>10.9x</td><td>↓</td></tr> <tr><td>24:</td><td>8.8</td><td>↑</td></tr> <tr><td>25:</td><td>9.8</td><td>↗</td></tr> <tr><td colspan="2">Serie</td><td style="text-align: right;">45</td></tr> <tr><td colspan="2">Total</td><td style="text-align: right;">232</td></tr> </table>	21:	9.6	←	22:	9.0	↗	23:	10.9x	↓	24:	8.8	↑	25:	9.8	↗	Serie		45	Total		232															
16:	9.5	→																																																									
17:	10.4x	↗																																																									
18:	10.2	↓																																																									
19:	10.0	↗																																																									
20:	9.2	↓																																																									
Serie		48																																																									
Total		187																																																									
21:	9.6	←																																																									
22:	9.0	↗																																																									
23:	10.9x	↓																																																									
24:	8.8	↑																																																									
25:	9.8	↗																																																									
Serie		45																																																									
Total		232																																																									
 <p style="text-align: center;">30 Skott</p>	<table style="width:100%; border-collapse: collapse;"> <tr><td>26:</td><td>10.4x</td><td>→</td></tr> <tr><td>27:</td><td>10.1</td><td>→</td></tr> <tr><td>28:</td><td>10.1</td><td>↗</td></tr> <tr><td>29:</td><td>10.5x</td><td>↗</td></tr> <tr><td>30:</td><td>9.9</td><td>↗</td></tr> <tr><td colspan="2">Serie</td><td style="text-align: right;">49</td></tr> <tr><td colspan="2">Total</td><td style="text-align: right;">281</td></tr> </table>	26:	10.4x	→	27:	10.1	→	28:	10.1	↗	29:	10.5x	↗	30:	9.9	↗	Serie		49	Total		281																																					
26:	10.4x	→																																																									
27:	10.1	→																																																									
28:	10.1	↗																																																									
29:	10.5x	↗																																																									
30:	9.9	↗																																																									
Serie		49																																																									
Total		281																																																									

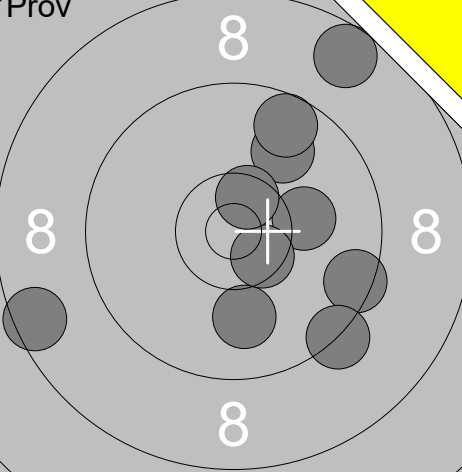
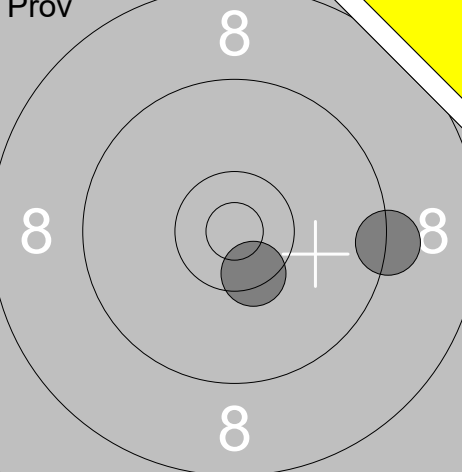
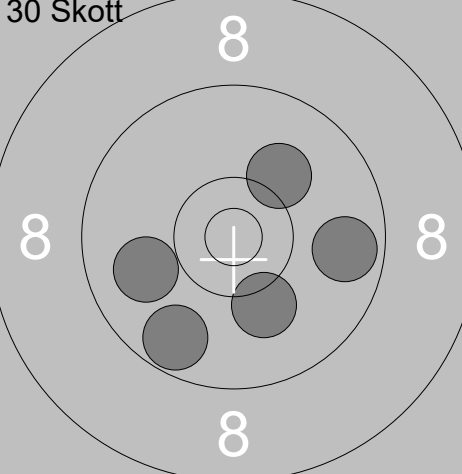
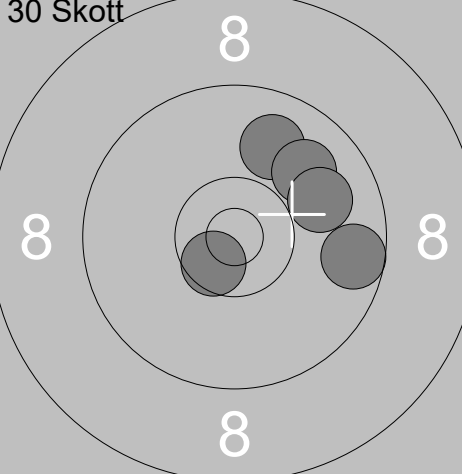
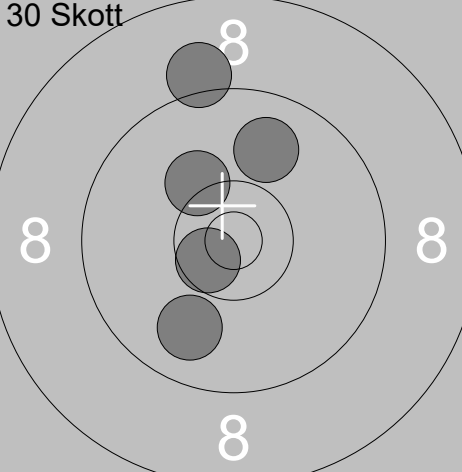
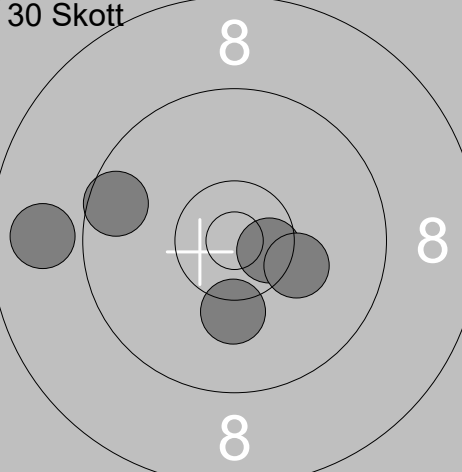
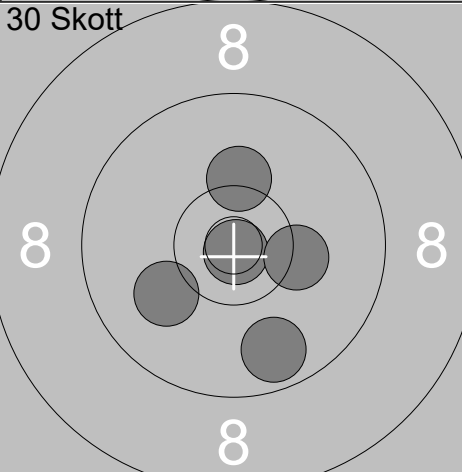
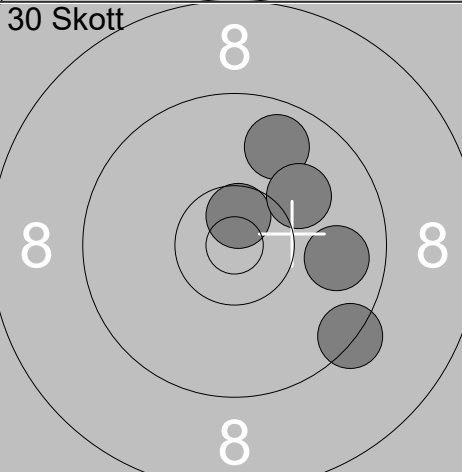
<p>Prov</p> 	<table border="1" style="width:100%; border-collapse: collapse;"> <tr><td>1:</td><td>8.6</td><td>↗</td></tr> <tr><td>2:</td><td>9.5</td><td>→</td></tr> <tr><td>3:</td><td>8.5</td><td>←</td></tr> <tr><td>4:</td><td>9.9</td><td>↗</td></tr> <tr><td>5:</td><td>9.3</td><td>↘</td></tr> <tr><td>6:</td><td>10.2</td><td>→</td></tr> <tr><td>7:</td><td>10.0</td><td>↓</td></tr> <tr><td>8:</td><td>10.5x</td><td>↘</td></tr> <tr><td>9:</td><td>9.6</td><td>↗</td></tr> <tr><td>10:</td><td>10.5x</td><td>↗</td></tr> <tr><td colspan="2">Serie</td><td>92</td></tr> <tr><td colspan="2">Total</td><td>0</td></tr> </table>	1:	8.6	↗	2:	9.5	→	3:	8.5	←	4:	9.9	↗	5:	9.3	↘	6:	10.2	→	7:	10.0	↓	8:	10.5x	↘	9:	9.6	↗	10:	10.5x	↗	Serie		92	Total		0	<p>Prov</p>  <table border="1" style="width:100%; border-collapse: collapse;"> <tr><td>11:</td><td>9.3</td><td>→</td></tr> <tr><td>12:</td><td>10.4x</td><td>↘</td></tr> <tr><td colspan="2">Serie</td><td>19</td></tr> <tr><td colspan="2">Total</td><td>0</td></tr> </table>	11:	9.3	→	12:	10.4x	↘	Serie		19	Total		0
1:	8.6	↗																																																
2:	9.5	→																																																
3:	8.5	←																																																
4:	9.9	↗																																																
5:	9.3	↘																																																
6:	10.2	→																																																
7:	10.0	↓																																																
8:	10.5x	↘																																																
9:	9.6	↗																																																
10:	10.5x	↗																																																
Serie		92																																																
Total		0																																																
11:	9.3	→																																																
12:	10.4x	↘																																																
Serie		19																																																
Total		0																																																
<p>30 Skott</p> 	<table border="1" style="width:100%; border-collapse: collapse;"> <tr><td>1:</td><td>10.1</td><td>↗</td></tr> <tr><td>2:</td><td>9.9</td><td>←</td></tr> <tr><td>3:</td><td>9.7</td><td>↘</td></tr> <tr><td>4:</td><td>10.1</td><td>↘</td></tr> <tr><td>5:</td><td>9.7</td><td>→</td></tr> <tr><td colspan="2">Serie</td><td>47</td></tr> <tr><td colspan="2">Total</td><td>47</td></tr> </table>	1:	10.1	↗	2:	9.9	←	3:	9.7	↘	4:	10.1	↘	5:	9.7	→	Serie		47	Total		47	<p>30 Skott</p>  <table border="1" style="width:100%; border-collapse: collapse;"> <tr><td>6:</td><td>9.9</td><td>↗</td></tr> <tr><td>7:</td><td>10.6x</td><td>↘</td></tr> <tr><td>8:</td><td>9.6</td><td>→</td></tr> <tr><td>9:</td><td>9.9</td><td>↗</td></tr> <tr><td>10:</td><td>9.9</td><td>→</td></tr> <tr><td colspan="2">Serie</td><td>46</td></tr> <tr><td colspan="2">Total</td><td>93</td></tr> </table>	6:	9.9	↗	7:	10.6x	↘	8:	9.6	→	9:	9.9	↗	10:	9.9	→	Serie		46	Total		93						
1:	10.1	↗																																																
2:	9.9	←																																																
3:	9.7	↘																																																
4:	10.1	↘																																																
5:	9.7	→																																																
Serie		47																																																
Total		47																																																
6:	9.9	↗																																																
7:	10.6x	↘																																																
8:	9.6	→																																																
9:	9.9	↗																																																
10:	9.9	→																																																
Serie		46																																																
Total		93																																																
<p>30 Skott</p> 	<table border="1" style="width:100%; border-collapse: collapse;"> <tr><td>11:</td><td>10.2</td><td>↖</td></tr> <tr><td>12:</td><td>9.1</td><td>↗</td></tr> <tr><td>13:</td><td>9.9</td><td>↗</td></tr> <tr><td>14:</td><td>10.6x</td><td>↘</td></tr> <tr><td>15:</td><td>9.9</td><td>↘</td></tr> <tr><td colspan="2">Serie</td><td>47</td></tr> <tr><td colspan="2">Total</td><td>140</td></tr> </table>	11:	10.2	↖	12:	9.1	↗	13:	9.9	↗	14:	10.6x	↘	15:	9.9	↘	Serie		47	Total		140	<p>30 Skott</p>  <table border="1" style="width:100%; border-collapse: collapse;"> <tr><td>16:</td><td>10.6x</td><td>→</td></tr> <tr><td>17:</td><td>8.9</td><td>←</td></tr> <tr><td>18:</td><td>10.2</td><td>↓</td></tr> <tr><td>19:</td><td>9.6</td><td>←</td></tr> <tr><td>20:</td><td>10.2</td><td>→</td></tr> <tr><td colspan="2">Serie</td><td>47</td></tr> <tr><td colspan="2">Total</td><td>187</td></tr> </table>	16:	10.6x	→	17:	8.9	←	18:	10.2	↓	19:	9.6	←	20:	10.2	→	Serie		47	Total		187						
11:	10.2	↖																																																
12:	9.1	↗																																																
13:	9.9	↗																																																
14:	10.6x	↘																																																
15:	9.9	↘																																																
Serie		47																																																
Total		140																																																
16:	10.6x	→																																																
17:	8.9	←																																																
18:	10.2	↓																																																
19:	9.6	←																																																
20:	10.2	→																																																
Serie		47																																																
Total		187																																																
<p>30 Skott</p> 	<table border="1" style="width:100%; border-collapse: collapse;"> <tr><td>21:</td><td>10.9x</td><td>↘</td></tr> <tr><td>22:</td><td>9.7</td><td>↘</td></tr> <tr><td>23:</td><td>10.0</td><td>↘</td></tr> <tr><td>24:</td><td>10.2</td><td>↗</td></tr> <tr><td>25:</td><td>10.3</td><td>→</td></tr> <tr><td colspan="2">Serie</td><td>49</td></tr> <tr><td colspan="2">Total</td><td>236</td></tr> </table>	21:	10.9x	↘	22:	9.7	↘	23:	10.0	↘	24:	10.2	↗	25:	10.3	→	Serie		49	Total		236	<p>30 Skott</p>  <table border="1" style="width:100%; border-collapse: collapse;"> <tr><td>26:</td><td>9.8</td><td>→</td></tr> <tr><td>27:</td><td>10.6x</td><td>↗</td></tr> <tr><td>28:</td><td>9.4</td><td>↘</td></tr> <tr><td>29:</td><td>9.8</td><td>↗</td></tr> <tr><td>30:</td><td>10.1</td><td>↗</td></tr> <tr><td colspan="2">Serie</td><td>47</td></tr> <tr><td colspan="2">Total</td><td>283</td></tr> </table>	26:	9.8	→	27:	10.6x	↗	28:	9.4	↘	29:	9.8	↗	30:	10.1	↗	Serie		47	Total		283						
21:	10.9x	↘																																																
22:	9.7	↘																																																
23:	10.0	↘																																																
24:	10.2	↗																																																
25:	10.3	→																																																
Serie		49																																																
Total		236																																																
26:	9.8	→																																																
27:	10.6x	↗																																																
28:	9.4	↘																																																
29:	9.8	↗																																																
30:	10.1	↗																																																
Serie		47																																																
Total		283																																																

<p>Prov</p>	<p>1: 8.3 ↗</p> <p>2: 10.6x ←</p> <p>3: 9.8 →</p> <p>4: 9.4 ↘</p> <p>5: 8.7 ↗</p> <p>6: 10.7x ↗</p> <p>7: 10.2 ←</p> <p>8: 6.2 ↘</p> <p>9: 10.0 ←</p> <p>10: 10.0 ↗</p>	<p>Prov</p>	<p>11: 10.8x ↗</p> <p>12: 10.3x ↑</p> <p>13: 9.6 ↗</p> <p>14: 10.5x ↖</p>
Serie 90		Serie 39	
Total 0		Total 0	
<p>30 Skott</p>	<p>1: 9.8 ↑</p> <p>2: 10.2 ↘</p> <p>3: 9.9 →</p> <p>4: 10.1 ↖</p> <p>5: 10.0 ↗</p>	<p>30 Skott</p>	<p>6: 9.5 ↖</p> <p>7: 10.2 →</p> <p>8: 9.9 ↗</p> <p>9: 10.4x ↗</p> <p>10: 10.3x ↖</p>
Serie 48		Serie 48	
Total 48		Total 96	
<p>30 Skott</p>	<p>11: 8.2 ↖</p> <p>12: 8.8 ↑</p> <p>13: 7.4 →</p> <p>14: 8.5 ↗</p> <p>15: 8.0 ↗</p>	<p>30 Skott</p>	<p>16: 9.9 ↘</p> <p>17: 9.1 ←</p> <p>18: 8.5 ↘</p> <p>19: 9.3 ↘</p> <p>20: 10.0 ↖</p>
Serie 39		Serie 45	
Total 135		Total 180	
<p>30 Skott</p>	<p>21: 8.9 ←</p> <p>22: 7.4 ←</p> <p>23: 8.8 ↖</p> <p>24: 8.9 ↘</p> <p>25: 8.7 ↗</p>	<p>30 Skott</p>	<p>26: 9.5 ←</p> <p>27: 8.4 ↖</p> <p>28: 9.2 ↗</p> <p>29: 9.4 ↗</p> <p>30: 9.2 ↗</p>
Serie 39		Serie 44	
Total 219		Total 263	

Skjutlag	Tavla	Beatrice Andersson	
3	2		
Ramselefors	Ramselefors		Vb
28.04.2019	Vindelnskottet 2019	Ramselefors SKF	
Prov 	1: 10.9x ↑ 2: 7.5 ↓ 3: 10.5x → 4: 9.2 ↓ 5: 8.2 ↓ 6: 7.9 ↗ 7: 7.6 ↓ 8: 9.8 ↑ 9: 8.5 ↓ 10: 7.9 ↓ Serie 82 Total 0	Prov 	11: 10.6x → 12: 10.6x → 13: 9.6 → 14: 9.3 ↓ Serie 38 Total 0
30 Skott 	1: 9.8 → 2: 9.4 → 3: 9.0 ← 4: 7.8 ↓ 5: 10.5x ↑ Serie 44 Total 44	30 Skott 	6: 8.4 ↓ 7: 8.4 ↓ 8: 9.9 → 9: 8.1 → 10: 10.0 ↗ Serie 43 Total 87
30 Skott 	11: 9.2 ↓ 12: 6.4 ↓ 13: 5.5 ↓ 14: 7.5 ↓ 15: 7.9 → Serie 34 Total 121	30 Skott 	16: 8.4 ↓ 17: 8.6 ← 18: 6.0 ← 19: 10.3 → 20: 9.6 ↓ Serie 41 Total 162
30 Skott 	21: 10.2 → 22: 10.6x ↑ 23: 8.1 ↓ 24: 2.8 ← 25: 8.1 → Serie 38 Total 200	30 Skott 	26: 7.6 → 27: 9.6 ↓ 28: 3.9 → 29: 9.5 ↓ 30: 3.5 → Serie 31 Total 231

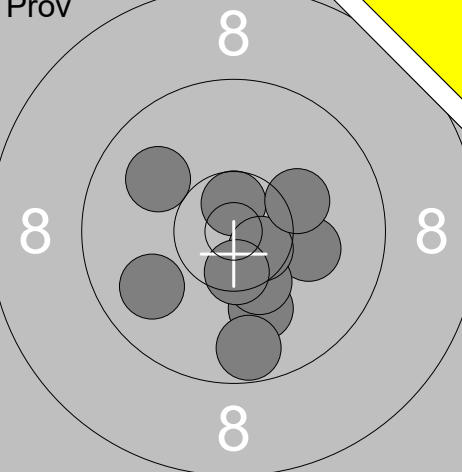
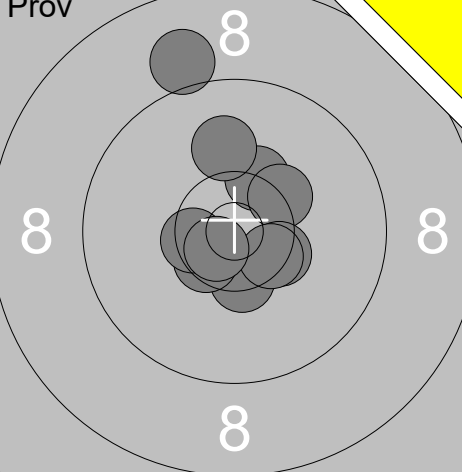
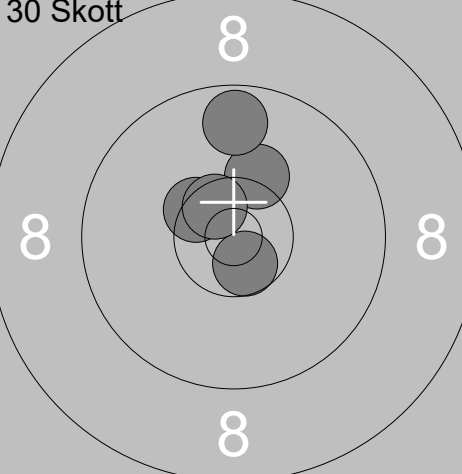
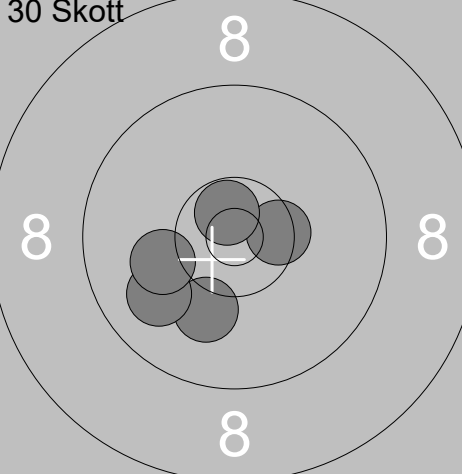
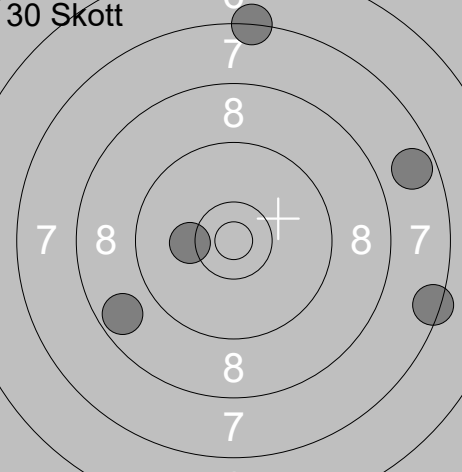
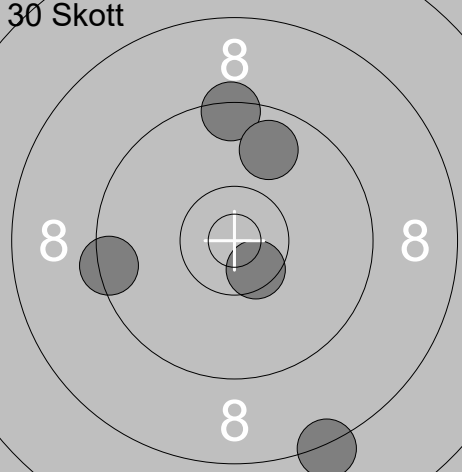
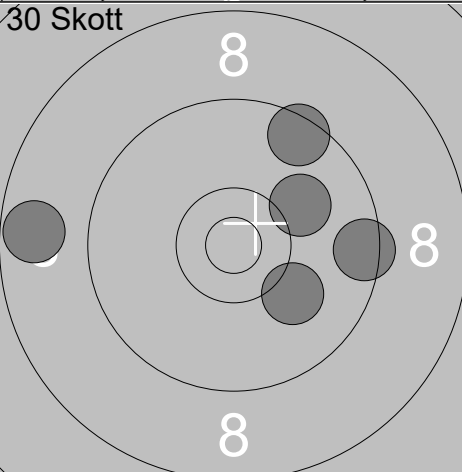
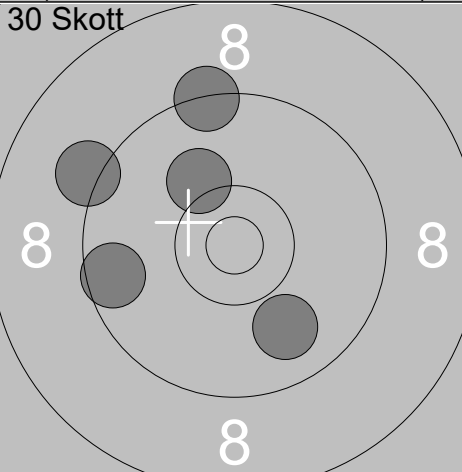

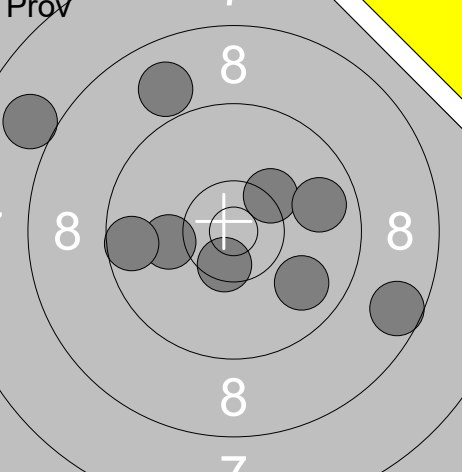
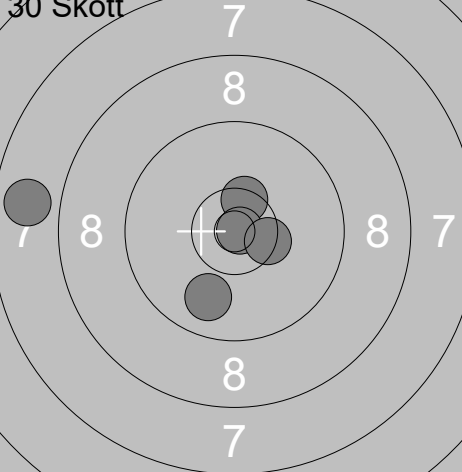
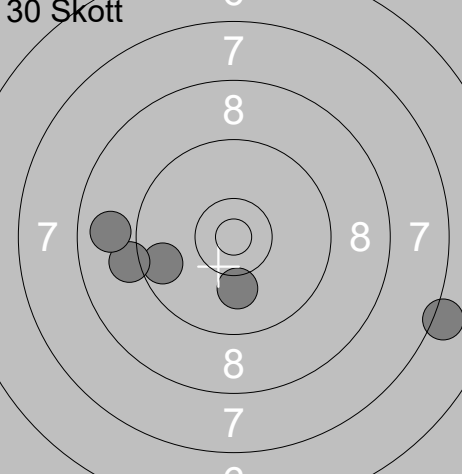
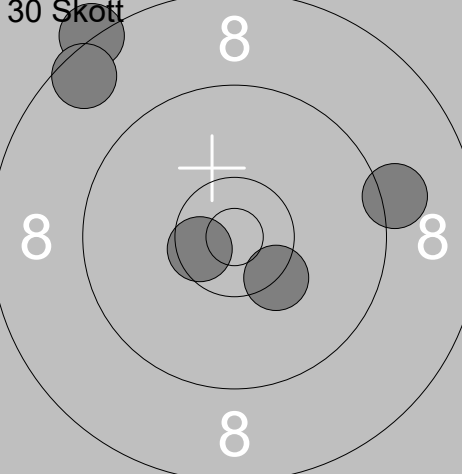
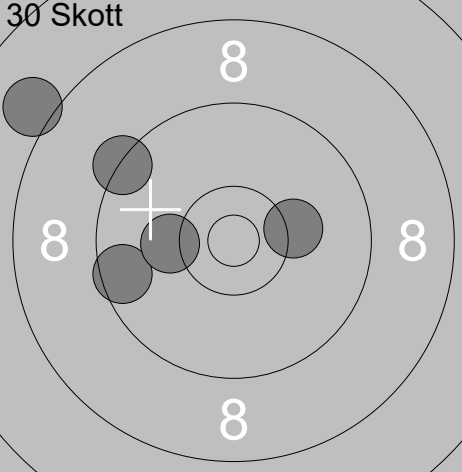
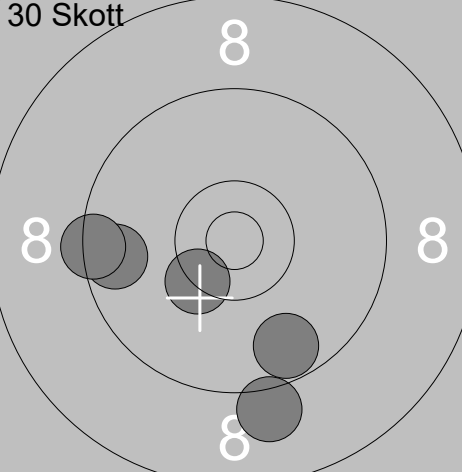
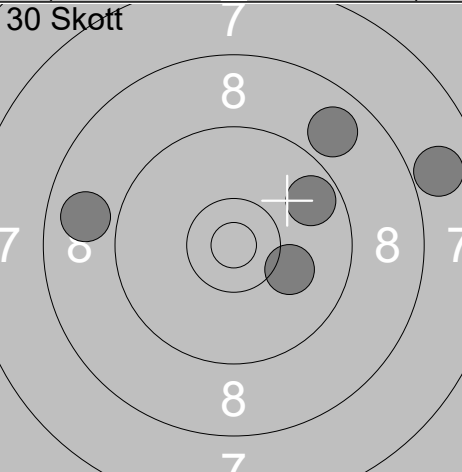
<p>Prov</p>  <table border="1" style="width:100%; border-collapse: collapse;"> <tr><td>1:</td><td>10.1</td><td>↓</td></tr> <tr><td>2:</td><td>9.9</td><td>↙</td></tr> <tr><td>3:</td><td>10.6x</td><td>↑</td></tr> <tr><td>4:</td><td>9.7</td><td>↓</td></tr> <tr><td>5:</td><td>10.1</td><td>→</td></tr> <tr><td>6:</td><td>10.3x</td><td>↘</td></tr> <tr><td>7:</td><td>10.0</td><td>↗</td></tr> <tr><td>8:</td><td>10.6x</td><td>↘</td></tr> <tr><td>9:</td><td>10.2</td><td>→</td></tr> <tr><td>10:</td><td>10.5x</td><td>↓</td></tr> <tr><td colspan="2">Serie</td><td style="text-align: right;">98</td></tr> <tr><td colspan="2">Total</td><td style="text-align: right;">0</td></tr> </table>	1:	10.1	↓	2:	9.9	↙	3:	10.6x	↑	4:	9.7	↓	5:	10.1	→	6:	10.3x	↘	7:	10.0	↗	8:	10.6x	↘	9:	10.2	→	10:	10.5x	↓	Serie		98	Total		0	<p>Prov</p>  <table border="1" style="width:100%; border-collapse: collapse;"> <tr><td>11:</td><td>10.4x</td><td>↓</td></tr> <tr><td>12:</td><td>10.5x</td><td>↙</td></tr> <tr><td>13:</td><td>10.3x</td><td>↑</td></tr> <tr><td>14:</td><td>10.0</td><td>↑</td></tr> <tr><td>15:</td><td>10.3x</td><td>↗</td></tr> <tr><td>16:</td><td>10.4x</td><td>→</td></tr> <tr><td>17:</td><td>10.5x</td><td>←</td></tr> <tr><td>18:</td><td>9.0</td><td>↑</td></tr> <tr><td>19:</td><td>10.5x</td><td>→</td></tr> <tr><td>20:</td><td>10.7x</td><td>↙</td></tr> <tr><td colspan="2">Serie</td><td style="text-align: right;">99</td></tr> <tr><td colspan="2">Total</td><td style="text-align: right;">0</td></tr> </table>	11:	10.4x	↓	12:	10.5x	↙	13:	10.3x	↑	14:	10.0	↑	15:	10.3x	↗	16:	10.4x	→	17:	10.5x	←	18:	9.0	↑	19:	10.5x	→	20:	10.7x	↙	Serie		99	Total		0
1:	10.1	↓																																																																							
2:	9.9	↙																																																																							
3:	10.6x	↑																																																																							
4:	9.7	↓																																																																							
5:	10.1	→																																																																							
6:	10.3x	↘																																																																							
7:	10.0	↗																																																																							
8:	10.6x	↘																																																																							
9:	10.2	→																																																																							
10:	10.5x	↓																																																																							
Serie		98																																																																							
Total		0																																																																							
11:	10.4x	↓																																																																							
12:	10.5x	↙																																																																							
13:	10.3x	↑																																																																							
14:	10.0	↑																																																																							
15:	10.3x	↗																																																																							
16:	10.4x	→																																																																							
17:	10.5x	←																																																																							
18:	9.0	↑																																																																							
19:	10.5x	→																																																																							
20:	10.7x	↙																																																																							
Serie		99																																																																							
Total		0																																																																							
<p>30 Skott</p>  <table border="1" style="width:100%; border-collapse: collapse;"> <tr><td>1:</td><td>10.4x</td><td>↖</td></tr> <tr><td>2:</td><td>10.6x</td><td>↓</td></tr> <tr><td>3:</td><td>10.2</td><td>↑</td></tr> <tr><td>4:</td><td>9.7</td><td>↑</td></tr> <tr><td>5:</td><td>10.6x</td><td>↗</td></tr> <tr><td colspan="2">Serie</td><td style="text-align: right;">49</td></tr> <tr><td colspan="2">Total</td><td style="text-align: right;">49</td></tr> </table>	1:	10.4x	↖	2:	10.6x	↓	3:	10.2	↑	4:	9.7	↑	5:	10.6x	↗	Serie		49	Total		49	<p>30 Skott</p>  <table border="1" style="width:100%; border-collapse: collapse;"> <tr><td>6:</td><td>10.1</td><td>↓</td></tr> <tr><td>7:</td><td>9.9</td><td>↙</td></tr> <tr><td>8:</td><td>10.5x</td><td>→</td></tr> <tr><td>9:</td><td>10.7x</td><td>↑</td></tr> <tr><td>10:</td><td>10.1</td><td>←</td></tr> <tr><td colspan="2">Serie</td><td style="text-align: right;">49</td></tr> <tr><td colspan="2">Total</td><td style="text-align: right;">98</td></tr> </table>	6:	10.1	↓	7:	9.9	↙	8:	10.5x	→	9:	10.7x	↑	10:	10.1	←	Serie		49	Total		98																														
1:	10.4x	↖																																																																							
2:	10.6x	↓																																																																							
3:	10.2	↑																																																																							
4:	9.7	↑																																																																							
5:	10.6x	↗																																																																							
Serie		49																																																																							
Total		49																																																																							
6:	10.1	↓																																																																							
7:	9.9	↙																																																																							
8:	10.5x	→																																																																							
9:	10.7x	↑																																																																							
10:	10.1	←																																																																							
Serie		49																																																																							
Total		98																																																																							
<p>30 Skott</p>  <table border="1" style="width:100%; border-collapse: collapse;"> <tr><td>11:</td><td>7.3</td><td>↑</td></tr> <tr><td>12:</td><td>7.7</td><td>→</td></tr> <tr><td>13:</td><td>7.4</td><td>→</td></tr> <tr><td>14:</td><td>10.2</td><td>←</td></tr> <tr><td>15:</td><td>8.7</td><td>↙</td></tr> <tr><td colspan="2">Serie</td><td style="text-align: right;">39</td></tr> <tr><td colspan="2">Total</td><td style="text-align: right;">137</td></tr> </table>	11:	7.3	↑	12:	7.7	→	13:	7.4	→	14:	10.2	←	15:	8.7	↙	Serie		39	Total		137	<p>30 Skott</p>  <table border="1" style="width:100%; border-collapse: collapse;"> <tr><td>16:</td><td>9.4</td><td>↑</td></tr> <tr><td>17:</td><td>9.8</td><td>↑</td></tr> <tr><td>18:</td><td>9.4</td><td>←</td></tr> <tr><td>19:</td><td>8.2</td><td>↓</td></tr> <tr><td>20:</td><td>10.5x</td><td>↘</td></tr> <tr><td colspan="2">Serie</td><td style="text-align: right;">45</td></tr> <tr><td colspan="2">Total</td><td style="text-align: right;">182</td></tr> </table>	16:	9.4	↑	17:	9.8	↑	18:	9.4	←	19:	8.2	↓	20:	10.5x	↘	Serie		45	Total		182																														
11:	7.3	↑																																																																							
12:	7.7	→																																																																							
13:	7.4	→																																																																							
14:	10.2	←																																																																							
15:	8.7	↙																																																																							
Serie		39																																																																							
Total		137																																																																							
16:	9.4	↑																																																																							
17:	9.8	↑																																																																							
18:	9.4	←																																																																							
19:	8.2	↓																																																																							
20:	10.5x	↘																																																																							
Serie		45																																																																							
Total		182																																																																							
<p>30 Skott</p>  <table border="1" style="width:100%; border-collapse: collapse;"> <tr><td>21:</td><td>9.5</td><td>↗</td></tr> <tr><td>22:</td><td>9.5</td><td>→</td></tr> <tr><td>23:</td><td>10.1</td><td>↗</td></tr> <tr><td>24:</td><td>8.7</td><td>←</td></tr> <tr><td>25:</td><td>10.1</td><td>↓</td></tr> <tr><td colspan="2">Serie</td><td style="text-align: right;">46</td></tr> <tr><td colspan="2">Total</td><td style="text-align: right;">228</td></tr> </table>	21:	9.5	↗	22:	9.5	→	23:	10.1	↗	24:	8.7	←	25:	10.1	↓	Serie		46	Total		228	<p>30 Skott</p>  <table border="1" style="width:100%; border-collapse: collapse;"> <tr><td>26:</td><td>10.2</td><td>↗</td></tr> <tr><td>27:</td><td>9.6</td><td>←</td></tr> <tr><td>28:</td><td>9.3</td><td>↑</td></tr> <tr><td>29:</td><td>9.9</td><td>↓</td></tr> <tr><td>30:</td><td>9.2</td><td>↖</td></tr> <tr><td colspan="2">Serie</td><td style="text-align: right;">46</td></tr> <tr><td colspan="2">Total</td><td style="text-align: right;">274</td></tr> </table>	26:	10.2	↗	27:	9.6	←	28:	9.3	↑	29:	9.9	↓	30:	9.2	↖	Serie		46	Total		274																														
21:	9.5	↗																																																																							
22:	9.5	→																																																																							
23:	10.1	↗																																																																							
24:	8.7	←																																																																							
25:	10.1	↓																																																																							
Serie		46																																																																							
Total		228																																																																							
26:	10.2	↗																																																																							
27:	9.6	←																																																																							
28:	9.3	↑																																																																							
29:	9.9	↓																																																																							
30:	9.2	↖																																																																							
Serie		46																																																																							
Total		274																																																																							

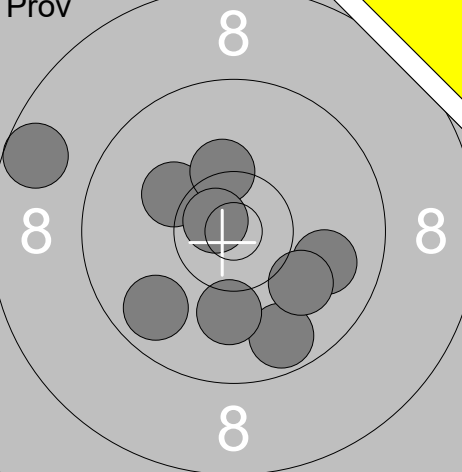
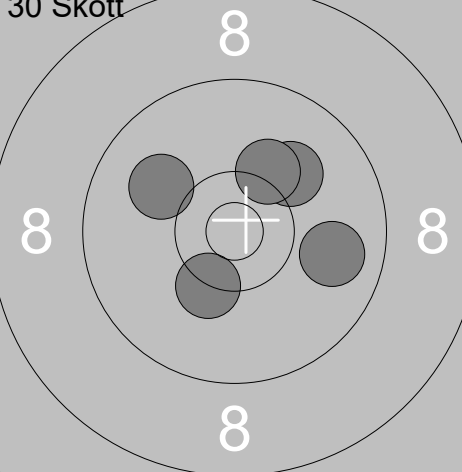
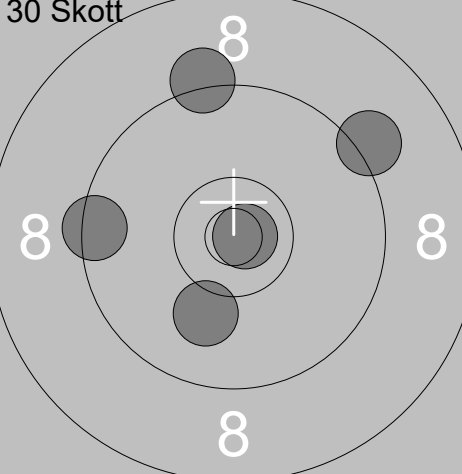
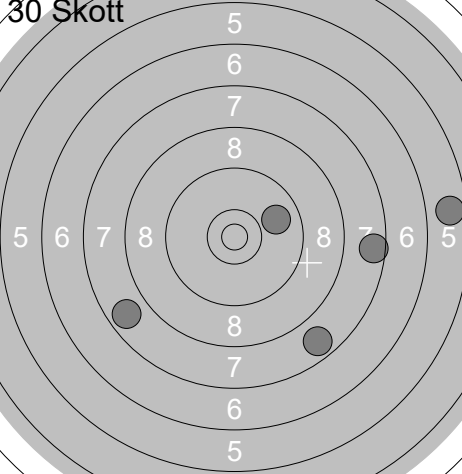
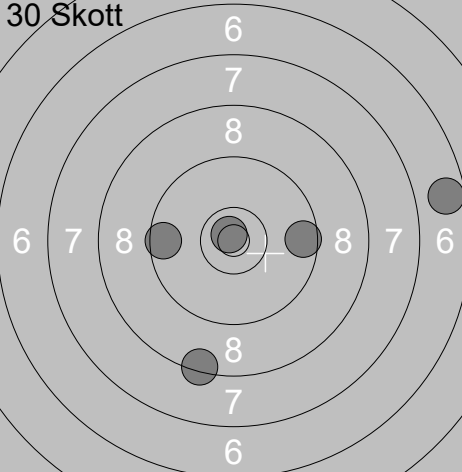
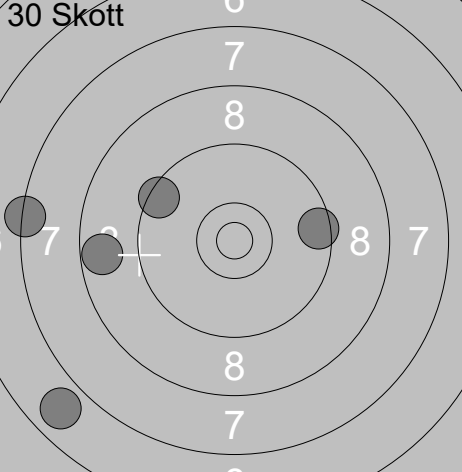
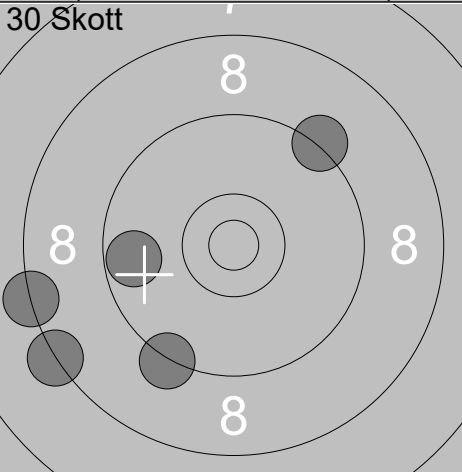
	<table border="1" style="width:100%; border-collapse: collapse;"> <tr><td>1:</td><td>10.3</td><td>↗</td></tr> <tr><td>2:</td><td>10.5x</td><td>↓</td></tr> <tr><td>3:</td><td>10.1</td><td>←</td></tr> <tr><td>4:</td><td>9.6</td><td>←</td></tr> <tr><td>5:</td><td>8.0</td><td>↗</td></tr> <tr><td>6:</td><td>9.9</td><td>↓</td></tr> <tr><td>7:</td><td>8.6</td><td>↘</td></tr> <tr><td>8:</td><td>8.9</td><td>↗</td></tr> <tr><td>9:</td><td>9.8</td><td>→</td></tr> </table>	1:	10.3	↗	2:	10.5x	↓	3:	10.1	←	4:	9.6	←	5:	8.0	↗	6:	9.9	↓	7:	8.6	↘	8:	8.9	↗	9:	9.8	→		<table border="1" style="width:100%; border-collapse: collapse;"> <tr><td>1:</td><td>10.5x</td><td>↗</td></tr> <tr><td>2:</td><td>7.8</td><td>←</td></tr> <tr><td>3:</td><td>10.9x</td><td>→</td></tr> <tr><td>4:</td><td>10.4x</td><td>→</td></tr> <tr><td>5:</td><td>9.9</td><td>↓</td></tr> </table>	1:	10.5x	↗	2:	7.8	←	3:	10.9x	→	4:	10.4x	→	5:	9.9	↓
1:	10.3	↗																																											
2:	10.5x	↓																																											
3:	10.1	←																																											
4:	9.6	←																																											
5:	8.0	↗																																											
6:	9.9	↓																																											
7:	8.6	↘																																											
8:	8.9	↗																																											
9:	9.8	→																																											
1:	10.5x	↗																																											
2:	7.8	←																																											
3:	10.9x	→																																											
4:	10.4x	→																																											
5:	9.9	↓																																											
	<table border="1" style="width:100%; border-collapse: collapse;"> <tr><td>6:</td><td>10.1</td><td>↓</td></tr> <tr><td>7:</td><td>9.7</td><td>←</td></tr> <tr><td>8:</td><td>9.1</td><td>←</td></tr> <tr><td>9:</td><td>8.9</td><td>←</td></tr> <tr><td>10:</td><td>7.1</td><td>→</td></tr> </table>	6:	10.1	↓	7:	9.7	←	8:	9.1	←	9:	8.9	←	10:	7.1	→		<table border="1" style="width:100%; border-collapse: collapse;"> <tr><td>11:</td><td>8.3</td><td>↗</td></tr> <tr><td>12:</td><td>8.6</td><td>↗</td></tr> <tr><td>13:</td><td>10.5x</td><td>←</td></tr> <tr><td>14:</td><td>10.3x</td><td>↓</td></tr> <tr><td>15:</td><td>9.2</td><td>→</td></tr> </table>	11:	8.3	↗	12:	8.6	↗	13:	10.5x	←	14:	10.3x	↓	15:	9.2	→												
6:	10.1	↓																																											
7:	9.7	←																																											
8:	9.1	←																																											
9:	8.9	←																																											
10:	7.1	→																																											
11:	8.3	↗																																											
12:	8.6	↗																																											
13:	10.5x	←																																											
14:	10.3x	↓																																											
15:	9.2	→																																											
	<table border="1" style="width:100%; border-collapse: collapse;"> <tr><td>16:</td><td>9.3</td><td>↗</td></tr> <tr><td>17:</td><td>9.6</td><td>←</td></tr> <tr><td>18:</td><td>8.0</td><td>↗</td></tr> <tr><td>19:</td><td>10.2</td><td>←</td></tr> <tr><td>20:</td><td>10.2</td><td>→</td></tr> </table>	16:	9.3	↗	17:	9.6	←	18:	8.0	↗	19:	10.2	←	20:	10.2	→		<table border="1" style="width:100%; border-collapse: collapse;"> <tr><td>21:</td><td>9.6</td><td>←</td></tr> <tr><td>22:</td><td>10.4x</td><td>↙</td></tr> <tr><td>23:</td><td>9.7</td><td>↓</td></tr> <tr><td>24:</td><td>9.1</td><td>↓</td></tr> <tr><td>25:</td><td>9.4</td><td>←</td></tr> </table>	21:	9.6	←	22:	10.4x	↙	23:	9.7	↓	24:	9.1	↓	25:	9.4	←												
16:	9.3	↗																																											
17:	9.6	←																																											
18:	8.0	↗																																											
19:	10.2	←																																											
20:	10.2	→																																											
21:	9.6	←																																											
22:	10.4x	↙																																											
23:	9.7	↓																																											
24:	9.1	↓																																											
25:	9.4	←																																											
	<table border="1" style="width:100%; border-collapse: collapse;"> <tr><td>26:</td><td>10.1</td><td>→</td></tr> <tr><td>27:</td><td>8.9</td><td>←</td></tr> <tr><td>28:</td><td>8.8</td><td>↗</td></tr> <tr><td>29:</td><td>7.9</td><td>→</td></tr> <tr><td>30:</td><td>9.7</td><td>↗</td></tr> </table>	26:	10.1	→	27:	8.9	←	28:	8.8	↗	29:	7.9	→	30:	9.7	↗																													
26:	10.1	→																																											
27:	8.9	←																																											
28:	8.8	↗																																											
29:	7.9	→																																											
30:	9.7	↗																																											

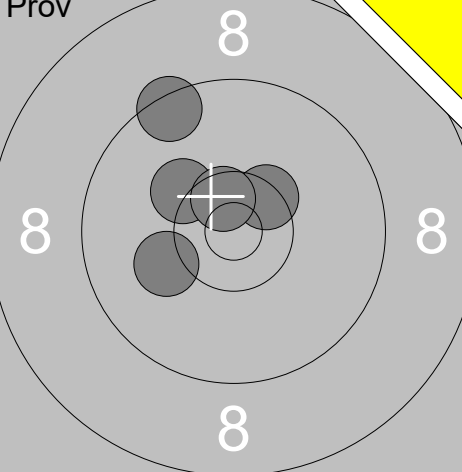
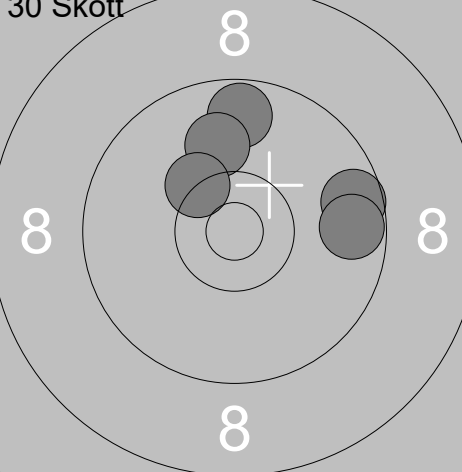
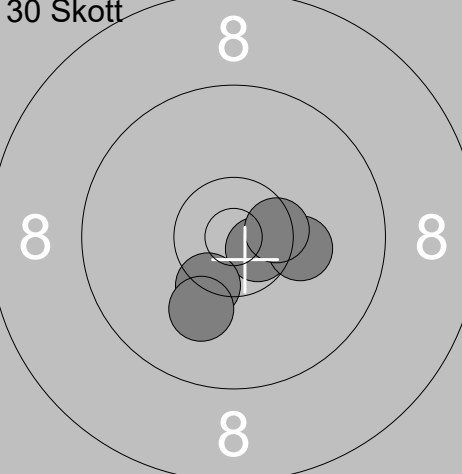
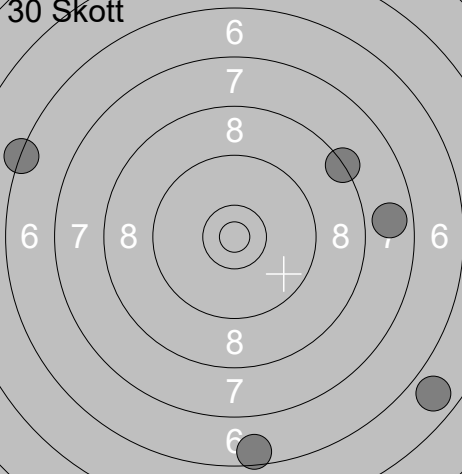
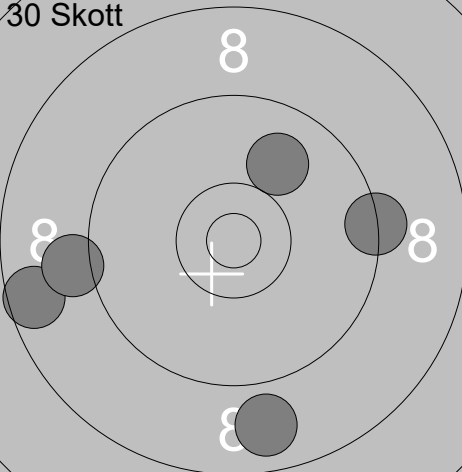
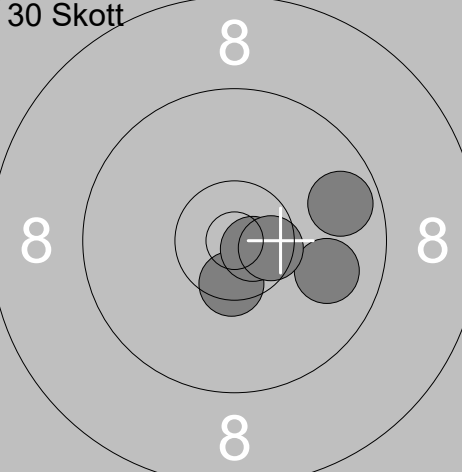
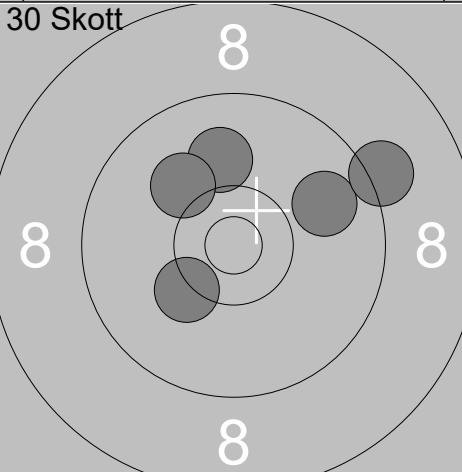
<p>Prov</p> 	<p>1: 8.6 ↖ 2: 10.2 ↗ 3: 9.9 → 4: 10.3x ↗ 5: 9.7 ↓ 6: 10.1 ↓ 7: 10.7x ↗ 8: 9.8 ↓ 9: 10.0 ↓</p> <p>Serie 85 Total 0</p>	<p>30 Skott</p>  <p>1: 10.3x ↓ 2: 10.0 ↖ 3: 10.1 ↗ 4: 10.2 ↗ 5: 9.9 →</p> <p>Serie 49 Total 49</p>
<p>30 Skott</p> 	<p>6: 9.2 ↗ 7: 9.4 ← 8: 10.8x → 9: 9.2 ↗ 10: 10.1 ↓</p> <p>Serie 47 Total 96</p>	<p>30 Skott</p>  <p>11: 9.9 ↗ 12: 5.7 → 13: 7.7 ↓ 14: 7.6 → 15: 7.8 ↖</p> <p>Serie 35 Total 131</p>
<p>30 Skott</p> 	<p>16: 6.7 → 17: 8.4 ↓ 18: 9.6 ← 19: 9.6 → 20: 10.8x ↗</p> <p>Serie 42 Total 173</p>	<p>30 Skott</p>  <p>21: 8.7 ← 22: 7.3 ← 23: 9.5 → 24: 9.5 ↖ 25: 6.8 ↖</p> <p>Serie 39 Total 212</p>
<p>30 Skott</p> 	<p>26: 9.7 ← 27: 8.3 ← 28: 9.3 ↗ 29: 9.3 ↓ 30: 8.3 ↖</p> <p>Serie 43 Total 255</p>	

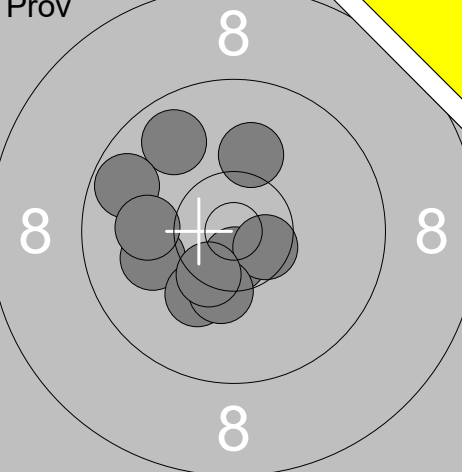
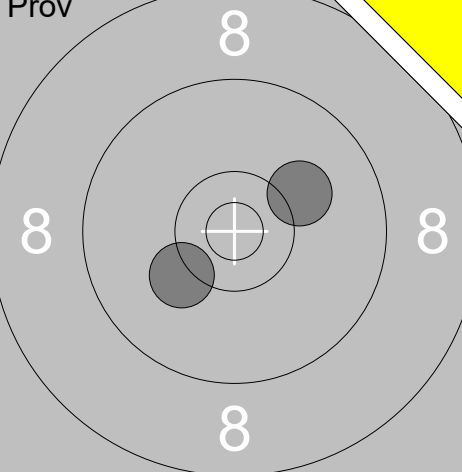
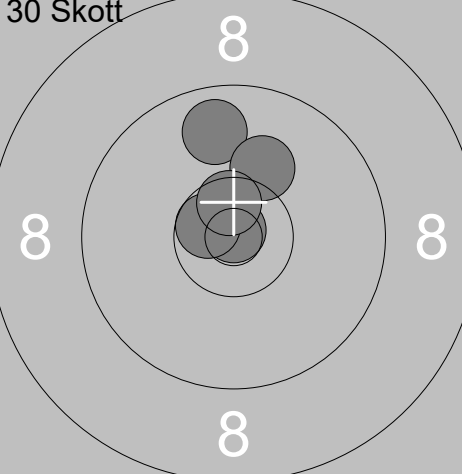
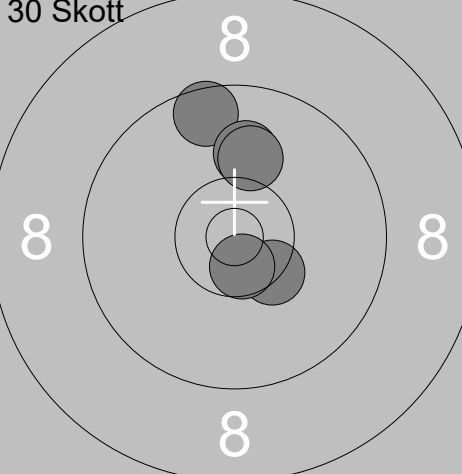
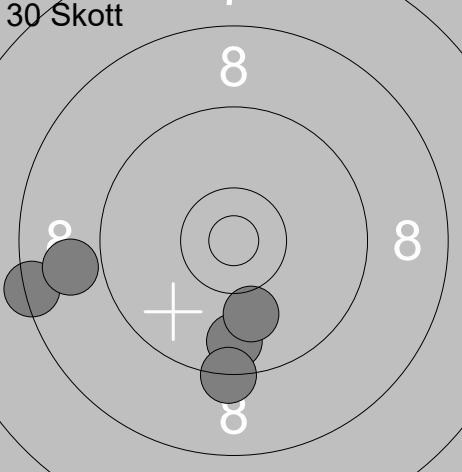
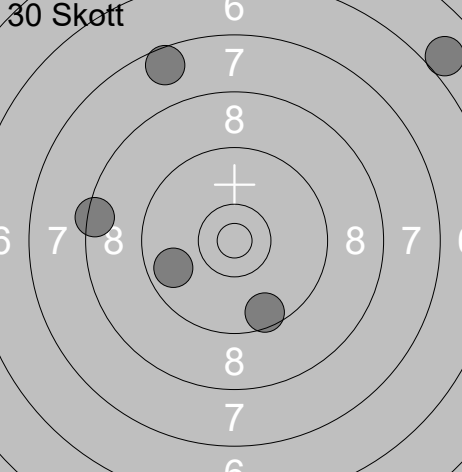
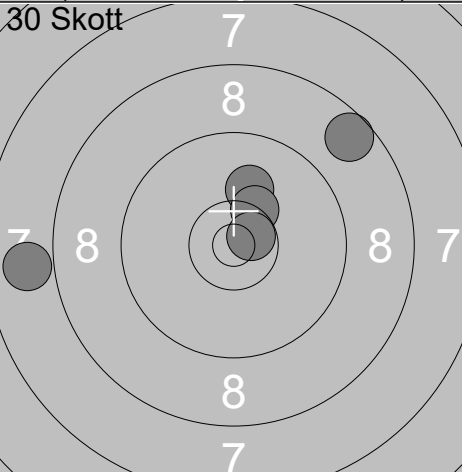
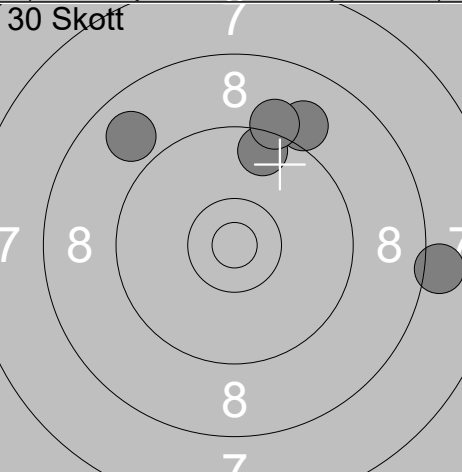
<p>Prov</p> 	<p>1: 10.2 ↖ 2: 10.4x ↗ 3: 9.4 ↖ 4: 10.1 ↖ 5: 10.6x ↖</p> <p>Serie 49 Total 0</p>	<p>30 Skott</p> 	<p>1: 9.7 ↑ 2: 10.0 ↑ 3: 9.6 → 4: 9.7 → 5: 10.3x ↖</p> <p>Serie 47 Total 47</p>
<p>30 Skott</p> 	<p>6: 10.7x → 7: 10.2 → 8: 10.4x ↓ 9: 10.5x → 10: 10.1 ↓</p> <p>Serie 50 Total 97</p>	<p>30 Skott</p> 	<p>11: 5.8 ↘ 12: 7.8 → 13: 6.6 ↓ 14: 6.3 ↖ 15: 8.3 ↗</p> <p>Serie 32 Total 129</p>
<p>30 Skott</p> 	<p>16: 9.3 → 17: 8.8 ↓ 18: 10.0 ↗ 19: 8.6 ↖ 20: 9.1 ↖</p> <p>Serie 44 Total 173</p>	<p>30 Skott</p> 	<p>21: 9.7 → 22: 9.9 → 23: 10.5x ↓ 24: 10.7x → 25: 10.6x →</p> <p>Serie 48 Total 221</p>
<p>30 Skott</p> 	<p>26: 9.9 → 27: 9.2 → 28: 10.0 ↑ 29: 10.1 ↖ 30: 10.2 ↖</p> <p>Serie 48 Total 269</p>		

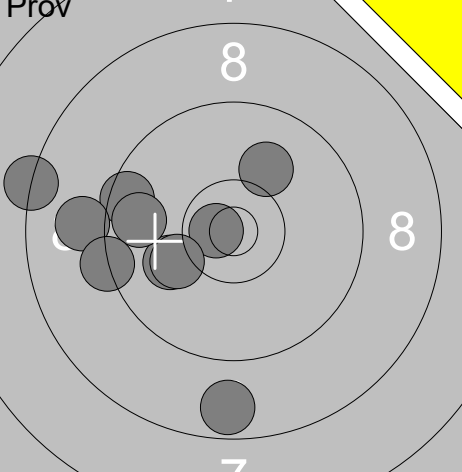
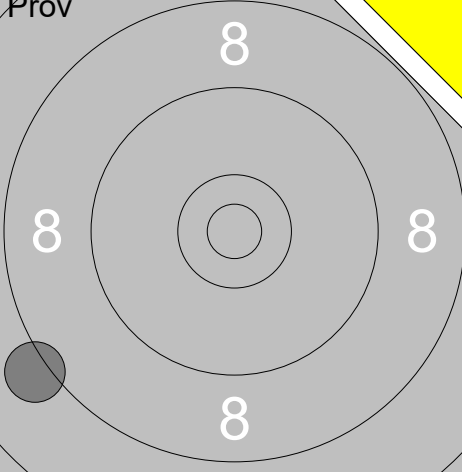
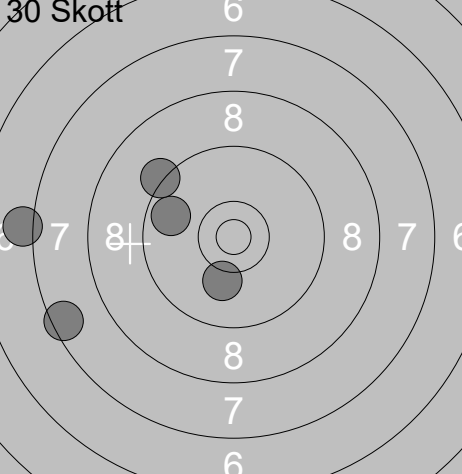
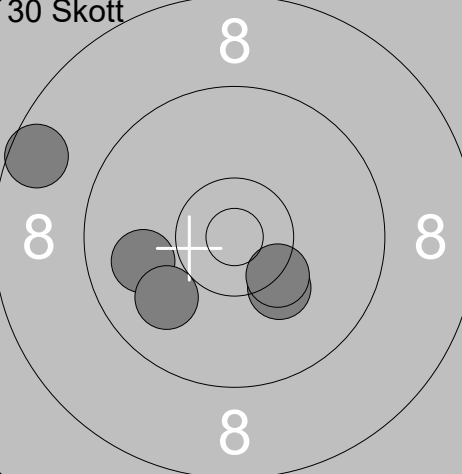
<p>Prov</p> 	<p>1: 9.8 ↗ 2: 10.0 ← 3: 9.7 ↗ 4: 10.1 ↑ 5: 10.6x ↓ 6: 10.2 ↓ 7: 10.6x ↘ 8: 10.3x ↓ 9: 10.4x ↓ 10: 10.0 ←</p> <p>Serie 98 Total 0</p>	<p>Prov</p> 	<p>11: 10.2 ↙ 12: 10.1 ↗</p> <p>Serie 20 Total 0</p>
<p>30 Skott</p> 	<p>1: 10.9x ↑ 2: 9.8 ↑ 3: 10.1 ↑ 4: 10.6x ↗ 5: 10.6x ↑</p> <p>Serie 49 Total 49</p>	<p>30 Skott</p> 	<p>6: 9.6 ↑ 7: 10.4x ↘ 8: 10.0 ↑ 9: 10.1 ↑ 10: 10.6x ↓</p> <p>Serie 49 Total 98</p>
<p>30 Skott</p> 	<p>11: 9.7 ↓ 12: 8.4 ← 13: 8.9 ← 14: 9.3 ↓ 15: 10.0 ↓</p> <p>Serie 44 Total 142</p>	<p>30 Skott</p> 	<p>16: 8.4 ← 17: 9.6 ↓ 18: 9.8 ← 19: 6.0 ↗ 20: 7.6 ↑</p> <p>Serie 39 Total 181</p>
<p>30 Skott</p> 	<p>21: 8.6 ↗ 22: 10.1 ↑ 23: 7.9 ← 24: 10.3x ↑ 25: 10.7x ↗</p> <p>Serie 45 Total 226</p>	<p>30 Skott</p> 	<p>26: 9.0 ↑ 27: 8.9 ↗ 28: 9.6 ↑ 29: 8.1 → 30: 9.2 ↑</p> <p>Serie 43 Total 269</p>

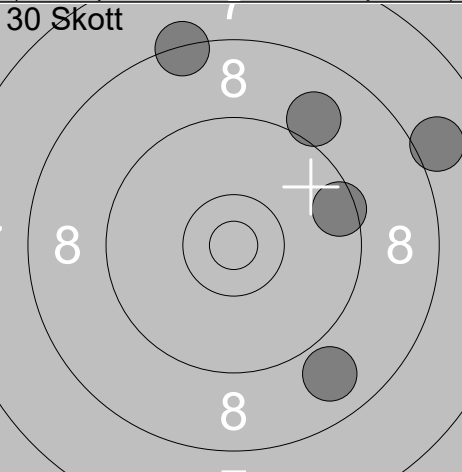
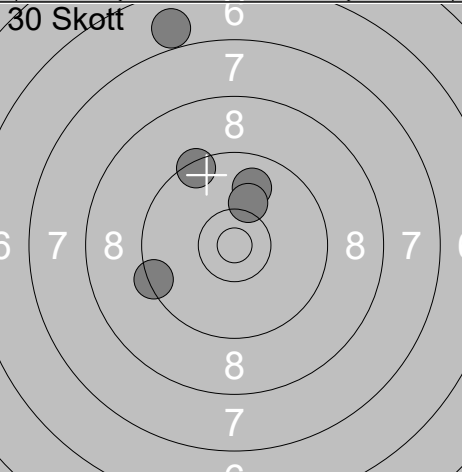
<p>Prov</p> 	<table border="1" style="width:100%; border-collapse: collapse;"> <tr><td>1:</td><td>10.1</td><td>↗</td></tr> <tr><td>2:</td><td>8.7</td><td>↓</td></tr> <tr><td>3:</td><td>8.3</td><td>←</td></tr> <tr><td>4:</td><td>10.1</td><td>←</td></tr> <tr><td>5:</td><td>10.7x</td><td>←</td></tr> <tr><td>6:</td><td>9.5</td><td>←</td></tr> <tr><td>7:</td><td>9.0</td><td>←</td></tr> <tr><td>8:</td><td>10.1</td><td>←</td></tr> <tr><td>9:</td><td>9.7</td><td>←</td></tr> <tr><td>10:</td><td>9.3</td><td>←</td></tr> <tr><td colspan="2">Serie</td><td style="text-align: right;">92</td></tr> <tr><td colspan="2">Total</td><td style="text-align: right;">0</td></tr> </table>	1:	10.1	↗	2:	8.7	↓	3:	8.3	←	4:	10.1	←	5:	10.7x	←	6:	9.5	←	7:	9.0	←	8:	10.1	←	9:	9.7	←	10:	9.3	←	Serie		92	Total		0	<p>Prov</p>  <table border="1" style="width:100%; border-collapse: collapse;"> <tr><td>11:</td><td>8.1</td><td>↙</td></tr> <tr><td colspan="2">Serie</td><td style="text-align: right;">8</td></tr> <tr><td colspan="2">Total</td><td style="text-align: right;">0</td></tr> </table>	11:	8.1	↙	Serie		8	Total		0
1:	10.1	↗																																													
2:	8.7	↓																																													
3:	8.3	←																																													
4:	10.1	←																																													
5:	10.7x	←																																													
6:	9.5	←																																													
7:	9.0	←																																													
8:	10.1	←																																													
9:	9.7	←																																													
10:	9.3	←																																													
Serie		92																																													
Total		0																																													
11:	8.1	↙																																													
Serie		8																																													
Total		0																																													
<p>30 Skott</p> 	<table border="1" style="width:100%; border-collapse: collapse;"> <tr><td>1:</td><td>9.7</td><td>←</td></tr> <tr><td>2:</td><td>10.1</td><td>↓</td></tr> <tr><td>3:</td><td>7.5</td><td>←</td></tr> <tr><td>4:</td><td>7.1</td><td>←</td></tr> <tr><td>5:</td><td>9.2</td><td>↗</td></tr> <tr><td colspan="2">Serie</td><td style="text-align: right;">42</td></tr> <tr><td colspan="2">Total</td><td style="text-align: right;">42</td></tr> </table>	1:	9.7	←	2:	10.1	↓	3:	7.5	←	4:	7.1	←	5:	9.2	↗	Serie		42	Total		42	<p>30 Skott</p>  <table border="1" style="width:100%; border-collapse: collapse;"> <tr><td>6:</td><td>10.2</td><td>↓</td></tr> <tr><td>7:</td><td>9.9</td><td>←</td></tr> <tr><td>8:</td><td>10.0</td><td>←</td></tr> <tr><td>9:</td><td>8.6</td><td>↗</td></tr> <tr><td>10:</td><td>10.3x</td><td>↘</td></tr> <tr><td colspan="2">Serie</td><td style="text-align: right;">47</td></tr> <tr><td colspan="2">Total</td><td style="text-align: right;">89</td></tr> </table>	6:	10.2	↓	7:	9.9	←	8:	10.0	←	9:	8.6	↗	10:	10.3x	↘	Serie		47	Total		89			
1:	9.7	←																																													
2:	10.1	↓																																													
3:	7.5	←																																													
4:	7.1	←																																													
5:	9.2	↗																																													
Serie		42																																													
Total		42																																													
6:	10.2	↓																																													
7:	9.9	←																																													
8:	10.0	←																																													
9:	8.6	↗																																													
10:	10.3x	↘																																													
Serie		47																																													
Total		89																																													
<p>30 Skott</p> 	<table border="1" style="width:100%; border-collapse: collapse;"> <tr><td>11:</td><td>6.6</td><td>←</td></tr> <tr><td>12:</td><td>9.4</td><td>→</td></tr> <tr><td>13:</td><td>7.1</td><td>↓</td></tr> <tr><td>14:</td><td>8.5</td><td>↙</td></tr> <tr><td>15:</td><td>8.5</td><td>↗</td></tr> <tr><td colspan="2">Serie</td><td style="text-align: right;">38</td></tr> <tr><td colspan="2">Total</td><td style="text-align: right;">127</td></tr> </table>	11:	6.6	←	12:	9.4	→	13:	7.1	↓	14:	8.5	↙	15:	8.5	↗	Serie		38	Total		127	<p>30 Skott</p>  <table border="1" style="width:100%; border-collapse: collapse;"> <tr><td>16:</td><td>9.3</td><td>↙</td></tr> <tr><td>17:</td><td>9.9</td><td>↑</td></tr> <tr><td>18:</td><td>7.2</td><td>←</td></tr> <tr><td>19:</td><td>8.4</td><td>→</td></tr> <tr><td>20:</td><td>9.1</td><td>↑</td></tr> <tr><td colspan="2">Serie</td><td style="text-align: right;">42</td></tr> <tr><td colspan="2">Total</td><td style="text-align: right;">169</td></tr> </table>	16:	9.3	↙	17:	9.9	↑	18:	7.2	←	19:	8.4	→	20:	9.1	↑	Serie		42	Total		169			
11:	6.6	←																																													
12:	9.4	→																																													
13:	7.1	↓																																													
14:	8.5	↙																																													
15:	8.5	↗																																													
Serie		38																																													
Total		127																																													
16:	9.3	↙																																													
17:	9.9	↑																																													
18:	7.2	←																																													
19:	8.4	→																																													
20:	9.1	↑																																													
Serie		42																																													
Total		169																																													
<p>30 Skott</p> 	<table border="1" style="width:100%; border-collapse: collapse;"> <tr><td>21:</td><td>8.0</td><td>↗</td></tr> <tr><td>22:</td><td>9.5</td><td>→</td></tr> <tr><td>23:</td><td>8.3</td><td>↑</td></tr> <tr><td>24:</td><td>8.9</td><td>↓</td></tr> <tr><td>25:</td><td>9.0</td><td>↗</td></tr> <tr><td colspan="2">Serie</td><td style="text-align: right;">42</td></tr> <tr><td colspan="2">Total</td><td style="text-align: right;">211</td></tr> </table>	21:	8.0	↗	22:	9.5	→	23:	8.3	↑	24:	8.9	↓	25:	9.0	↗	Serie		42	Total		211	<p>30 Skott</p>  <table border="1" style="width:100%; border-collapse: collapse;"> <tr><td>26:</td><td>9.9</td><td>↑</td></tr> <tr><td>27:</td><td>9.4</td><td>←</td></tr> <tr><td>28:</td><td>6.9</td><td>↑</td></tr> <tr><td>29:</td><td>9.4</td><td>↗</td></tr> <tr><td>30:</td><td>10.2</td><td>↑</td></tr> <tr><td colspan="2">Serie</td><td style="text-align: right;">43</td></tr> <tr><td colspan="2">Total</td><td style="text-align: right;">254</td></tr> </table>	26:	9.9	↑	27:	9.4	←	28:	6.9	↑	29:	9.4	↗	30:	10.2	↑	Serie		43	Total		254			
21:	8.0	↗																																													
22:	9.5	→																																													
23:	8.3	↑																																													
24:	8.9	↓																																													
25:	9.0	↗																																													
Serie		42																																													
Total		211																																													
26:	9.9	↑																																													
27:	9.4	←																																													
28:	6.9	↑																																													
29:	9.4	↗																																													
30:	10.2	↑																																													
Serie		43																																													
Total		254																																													

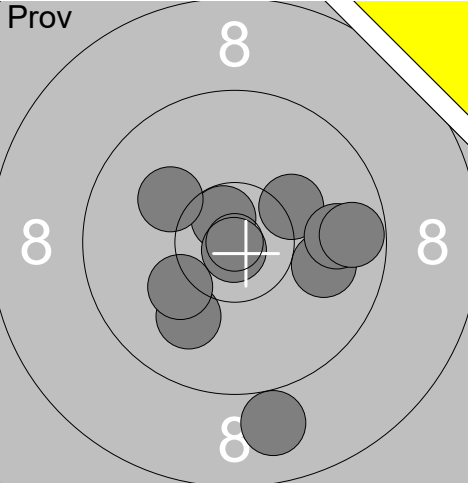
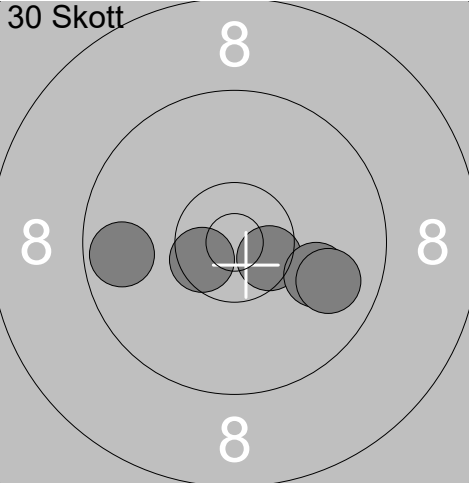
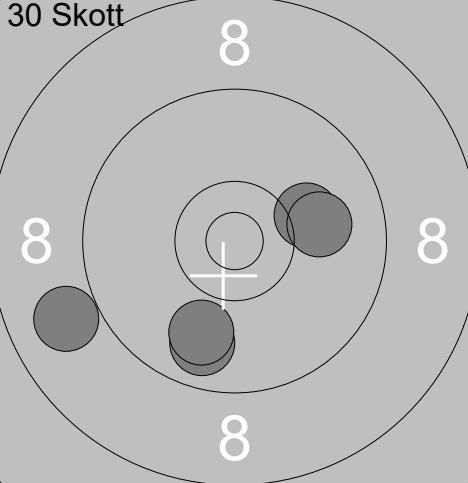
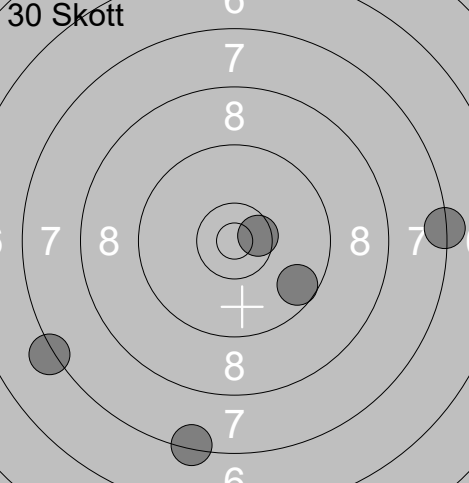
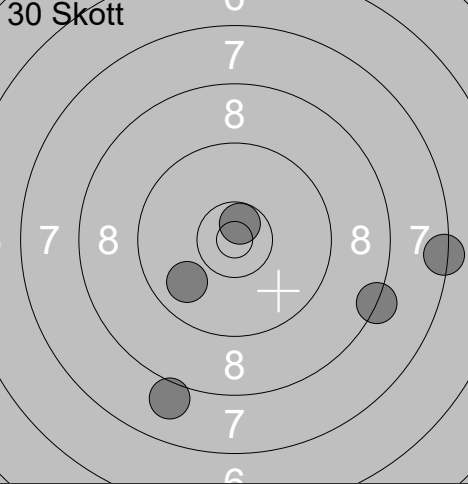
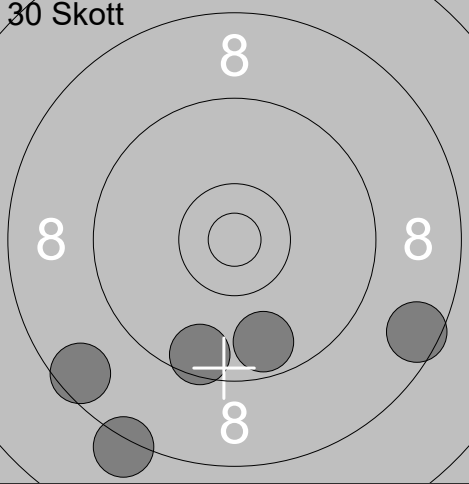
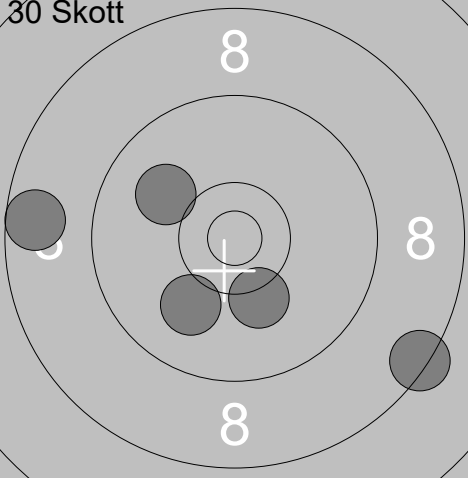
Skjutlag 4	Tavla 7	Roger Andersson	
Ramselefors	S 3		No
28.04.2019	Vindelnskottet 2019	Ramselefors SKF	
Prov		1: 10.2 ↗ 2: 8.9 ↓ 3: 9.9 → 4: 9.8 → 5: 10.7x ↗ 6: 10.0 ↓ 7: 10.2 ← 8: 10.9x ↓ 9: 9.7 → 10: 10.1 ↗ Serie 95 Total 0	30 Skott
			
			1: 10.5x ↗ 2: 10.0 → 3: 9.8 → 4: 10.5x ← 5: 9.7 ← Serie 48 Total 48
30 Skott		6: 8.9 ← 7: 10.1 → 8: 10.0 → 9: 9.8 ↓ 10: 9.9 ↓ Serie 46 Total 94	30 Skott
			
			11: 7.2 ← 12: 7.3 → 13: 10.5x → 14: 9.6 → 15: 7.4 ↓ Serie 40 Total 134
30 Skott		16: 7.4 → 17: 10.7x ↗ 18: 8.0 ↓ 19: 8.3 → 20: 9.9 ← Serie 42 Total 176	30 Skott
			
			21: 8.6 → 22: 8.6 ← 23: 9.7 ↓ 24: 9.5 ↓ 25: 8.2 ↓ Serie 42 Total 218
30 Skott		26: 10.0 ↓ 27: 8.6 ← 28: 8.4 ↓ 29: 10.2 ↓ 30: 10.0 ↗ Serie 46 Total 264	

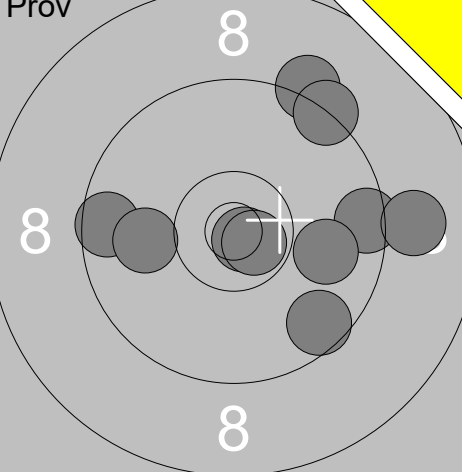
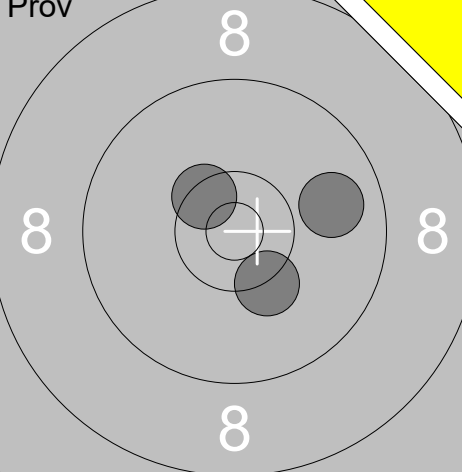
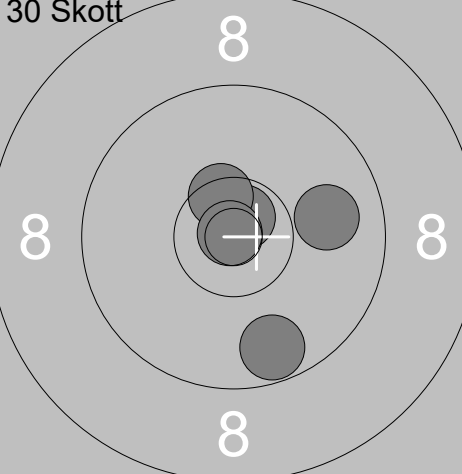
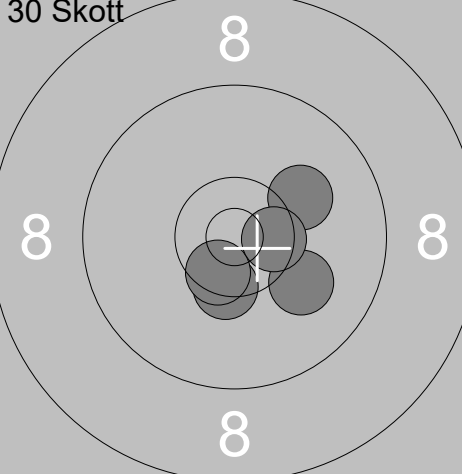
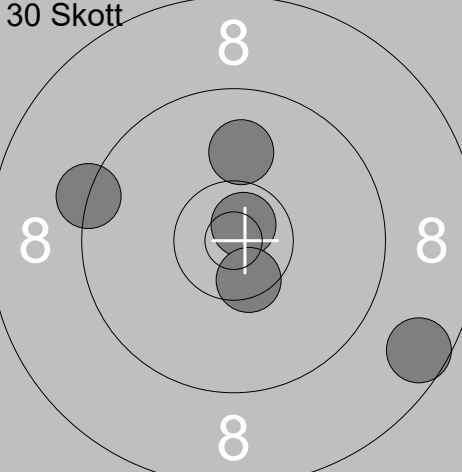
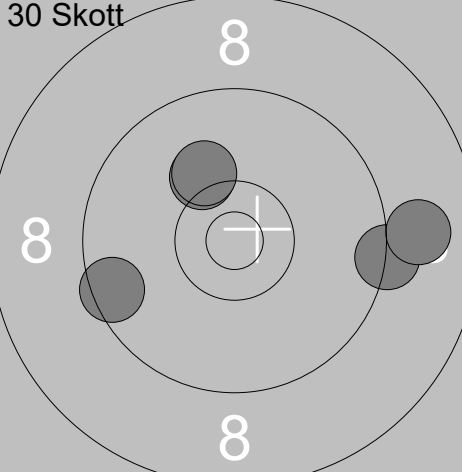
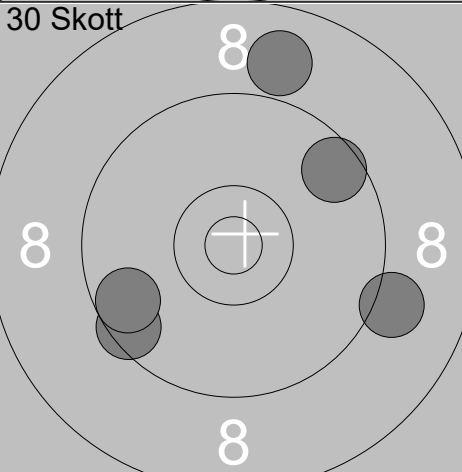
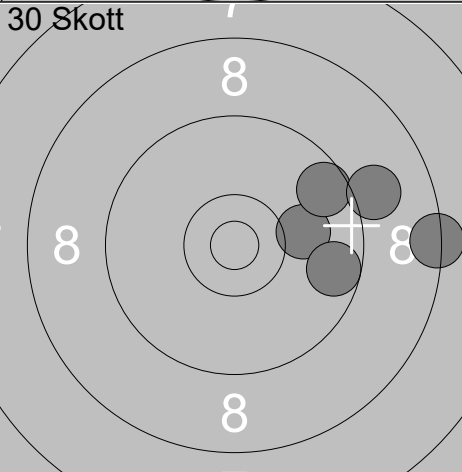
<p>Prov</p> 	<table style="width:100%; border-collapse: collapse;"> <tr><td>1:</td><td>9.6</td><td>↘</td></tr> <tr><td>2:</td><td>9.5</td><td>→</td></tr> <tr><td>3:</td><td>9.9</td><td>→</td></tr> <tr><td>4:</td><td>9.0</td><td>→</td></tr> <tr><td>5:</td><td>9.2</td><td>↗</td></tr> <tr><td>6:</td><td>10.8x</td><td>↘</td></tr> <tr><td>7:</td><td>9.3</td><td>↗</td></tr> <tr><td>8:</td><td>9.6</td><td>←</td></tr> <tr><td>9:</td><td>10.0</td><td>←</td></tr> <tr><td>10:</td><td>10.7x</td><td>↘</td></tr> </table> <table style="width:100%; border-collapse: collapse; margin-top: 5px;"> <tr><td style="border-top: 1px solid black;">Serie</td><td style="border-top: 1px solid black; text-align: right;">93</td></tr> <tr><td style="border-top: 1px solid black;">Total</td><td style="border-top: 1px solid black; text-align: right;">0</td></tr> </table>	1:	9.6	↘	2:	9.5	→	3:	9.9	→	4:	9.0	→	5:	9.2	↗	6:	10.8x	↘	7:	9.3	↗	8:	9.6	←	9:	10.0	←	10:	10.7x	↘	Serie	93	Total	0	<p>Prov</p> 	<table style="width:100%; border-collapse: collapse;"> <tr><td>11:</td><td>9.9</td><td>→</td></tr> <tr><td>12:</td><td>10.3</td><td>↘</td></tr> <tr><td>13:</td><td>10.4x</td><td>↗</td></tr> </table> <table style="width:100%; border-collapse: collapse; margin-top: 5px;"> <tr><td style="border-top: 1px solid black;">Serie</td><td style="border-top: 1px solid black; text-align: right;">29</td></tr> <tr><td style="border-top: 1px solid black;">Total</td><td style="border-top: 1px solid black; text-align: right;">0</td></tr> </table>	11:	9.9	→	12:	10.3	↘	13:	10.4x	↗	Serie	29	Total	0
1:	9.6	↘																																																
2:	9.5	→																																																
3:	9.9	→																																																
4:	9.0	→																																																
5:	9.2	↗																																																
6:	10.8x	↘																																																
7:	9.3	↗																																																
8:	9.6	←																																																
9:	10.0	←																																																
10:	10.7x	↘																																																
Serie	93																																																	
Total	0																																																	
11:	9.9	→																																																
12:	10.3	↘																																																
13:	10.4x	↗																																																
Serie	29																																																	
Total	0																																																	
<p>30 Skott</p> 	<table style="width:100%; border-collapse: collapse;"> <tr><td>1:</td><td>10.7x</td><td>↗</td></tr> <tr><td>2:</td><td>10.5x</td><td>↗</td></tr> <tr><td>3:</td><td>9.9</td><td>→</td></tr> <tr><td>4:</td><td>9.7</td><td>↘</td></tr> <tr><td>5:</td><td>10.9x</td><td>↗</td></tr> </table> <table style="width:100%; border-collapse: collapse; margin-top: 5px;"> <tr><td style="border-top: 1px solid black;">Serie</td><td style="border-top: 1px solid black; text-align: right;">48</td></tr> <tr><td style="border-top: 1px solid black;">Total</td><td style="border-top: 1px solid black; text-align: right;">48</td></tr> </table>	1:	10.7x	↗	2:	10.5x	↗	3:	9.9	→	4:	9.7	↘	5:	10.9x	↗	Serie	48	Total	48	<p>30 Skott</p> 	<table style="width:100%; border-collapse: collapse;"> <tr><td>6:</td><td>10.1</td><td>↗</td></tr> <tr><td>7:</td><td>10.4x</td><td>↘</td></tr> <tr><td>8:</td><td>10.5x</td><td>↘</td></tr> <tr><td>9:</td><td>10.1</td><td>↘</td></tr> <tr><td>10:</td><td>10.5x</td><td>→</td></tr> </table> <table style="width:100%; border-collapse: collapse; margin-top: 5px;"> <tr><td style="border-top: 1px solid black;">Serie</td><td style="border-top: 1px solid black; text-align: right;">50</td></tr> <tr><td style="border-top: 1px solid black;">Total</td><td style="border-top: 1px solid black; text-align: right;">98</td></tr> </table>	6:	10.1	↗	7:	10.4x	↘	8:	10.5x	↘	9:	10.1	↘	10:	10.5x	→	Serie	50	Total	98									
1:	10.7x	↗																																																
2:	10.5x	↗																																																
3:	9.9	→																																																
4:	9.7	↘																																																
5:	10.9x	↗																																																
Serie	48																																																	
Total	48																																																	
6:	10.1	↗																																																
7:	10.4x	↘																																																
8:	10.5x	↘																																																
9:	10.1	↘																																																
10:	10.5x	→																																																
Serie	50																																																	
Total	98																																																	
<p>30 Skott</p> 	<table style="width:100%; border-collapse: collapse;"> <tr><td>11:</td><td>10.7x</td><td>↗</td></tr> <tr><td>12:</td><td>9.3</td><td>←</td></tr> <tr><td>13:</td><td>10.5x</td><td>↘</td></tr> <tr><td>14:</td><td>8.6</td><td>↘</td></tr> <tr><td>15:</td><td>10.0</td><td>↑</td></tr> </table> <table style="width:100%; border-collapse: collapse; margin-top: 5px;"> <tr><td style="border-top: 1px solid black;">Serie</td><td style="border-top: 1px solid black; text-align: right;">47</td></tr> <tr><td style="border-top: 1px solid black;">Total</td><td style="border-top: 1px solid black; text-align: right;">145</td></tr> </table>	11:	10.7x	↗	12:	9.3	←	13:	10.5x	↘	14:	8.6	↘	15:	10.0	↑	Serie	47	Total	145	<p>30 Skott</p> 	<table style="width:100%; border-collapse: collapse;"> <tr><td>16:</td><td>10.2</td><td>↗</td></tr> <tr><td>17:</td><td>9.3</td><td>→</td></tr> <tr><td>18:</td><td>10.1</td><td>↗</td></tr> <tr><td>19:</td><td>9.5</td><td>←</td></tr> <tr><td>20:</td><td>9.0</td><td>→</td></tr> </table> <table style="width:100%; border-collapse: collapse; margin-top: 5px;"> <tr><td style="border-top: 1px solid black;">Serie</td><td style="border-top: 1px solid black; text-align: right;">47</td></tr> <tr><td style="border-top: 1px solid black;">Total</td><td style="border-top: 1px solid black; text-align: right;">192</td></tr> </table>	16:	10.2	↗	17:	9.3	→	18:	10.1	↗	19:	9.5	←	20:	9.0	→	Serie	47	Total	192									
11:	10.7x	↗																																																
12:	9.3	←																																																
13:	10.5x	↘																																																
14:	8.6	↘																																																
15:	10.0	↑																																																
Serie	47																																																	
Total	145																																																	
16:	10.2	↗																																																
17:	9.3	→																																																
18:	10.1	↗																																																
19:	9.5	←																																																
20:	9.0	→																																																
Serie	47																																																	
Total	192																																																	
<p>30 Skott</p> 	<table style="width:100%; border-collapse: collapse;"> <tr><td>21:</td><td>9.5</td><td>↖</td></tr> <tr><td>22:</td><td>9.7</td><td>↖</td></tr> <tr><td>23:</td><td>9.1</td><td>→</td></tr> <tr><td>24:</td><td>8.9</td><td>↑</td></tr> <tr><td>25:</td><td>9.6</td><td>↗</td></tr> </table> <table style="width:100%; border-collapse: collapse; margin-top: 5px;"> <tr><td style="border-top: 1px solid black;">Serie</td><td style="border-top: 1px solid black; text-align: right;">44</td></tr> <tr><td style="border-top: 1px solid black;">Total</td><td style="border-top: 1px solid black; text-align: right;">236</td></tr> </table>	21:	9.5	↖	22:	9.7	↖	23:	9.1	→	24:	8.9	↑	25:	9.6	↗	Serie	44	Total	236	<p>30 Skott</p> 	<table style="width:100%; border-collapse: collapse;"> <tr><td>26:</td><td>10.1</td><td>→</td></tr> <tr><td>27:</td><td>8.4</td><td>→</td></tr> <tr><td>28:</td><td>9.6</td><td>↗</td></tr> <tr><td>29:</td><td>9.7</td><td>→</td></tr> <tr><td>30:</td><td>9.0</td><td>→</td></tr> </table> <table style="width:100%; border-collapse: collapse; margin-top: 5px;"> <tr><td style="border-top: 1px solid black;">Serie</td><td style="border-top: 1px solid black; text-align: right;">45</td></tr> <tr><td style="border-top: 1px solid black;">Total</td><td style="border-top: 1px solid black; text-align: right;">281</td></tr> </table>	26:	10.1	→	27:	8.4	→	28:	9.6	↗	29:	9.7	→	30:	9.0	→	Serie	45	Total	281									
21:	9.5	↖																																																
22:	9.7	↖																																																
23:	9.1	→																																																
24:	8.9	↑																																																
25:	9.6	↗																																																
Serie	44																																																	
Total	236																																																	
26:	10.1	→																																																
27:	8.4	→																																																
28:	9.6	↗																																																
29:	9.7	→																																																
30:	9.0	→																																																
Serie	45																																																	
Total	281																																																	

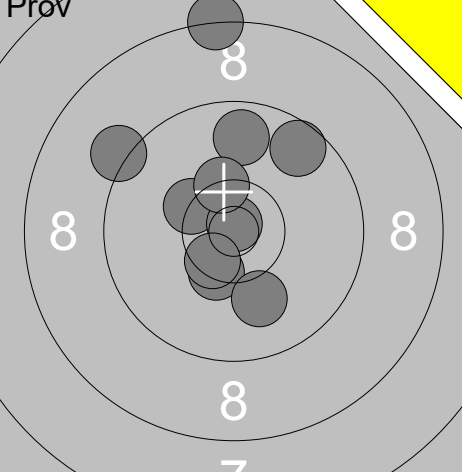
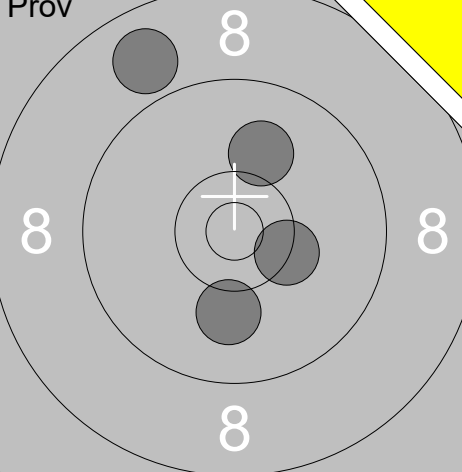
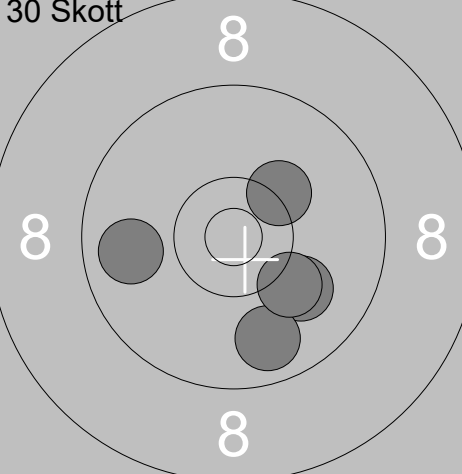
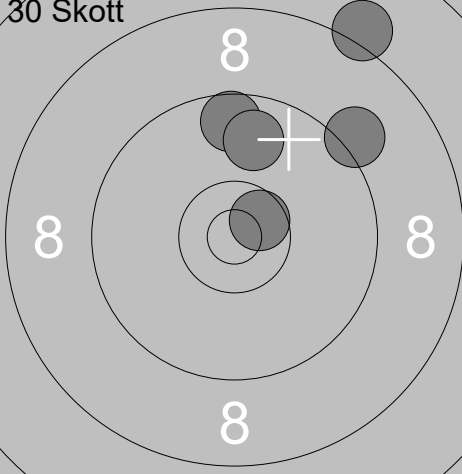
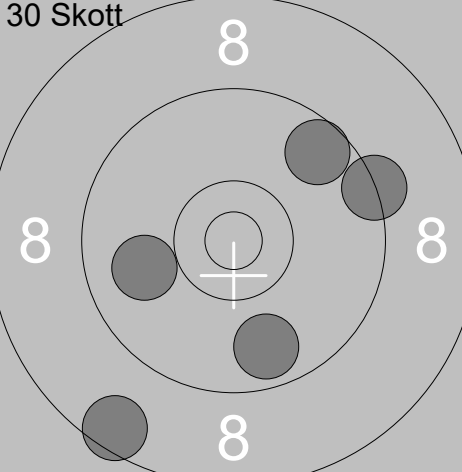
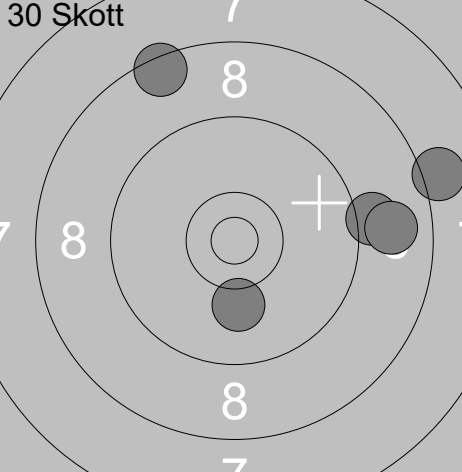
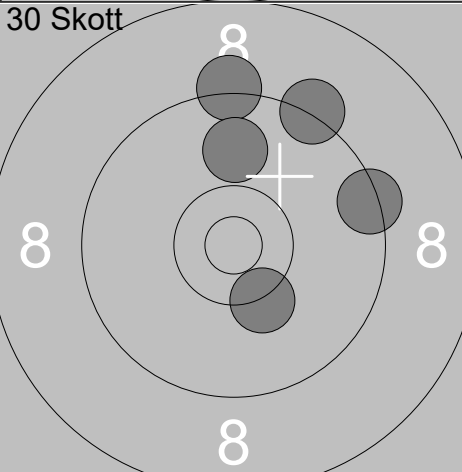
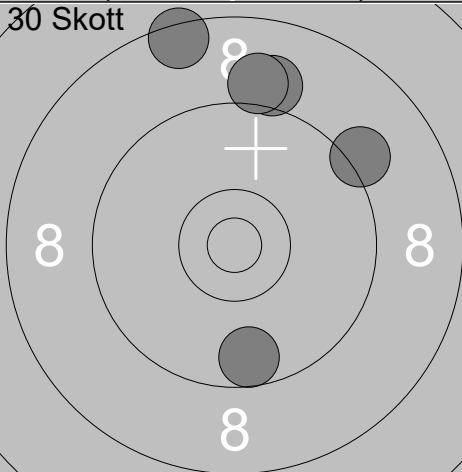

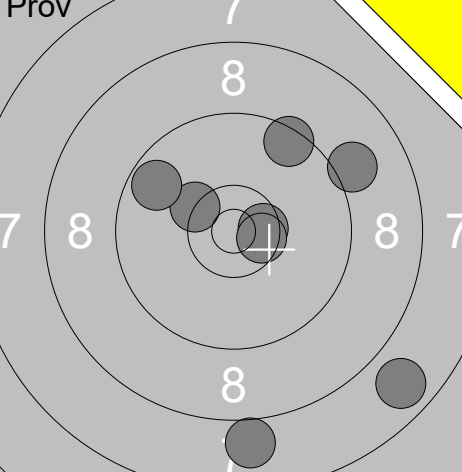
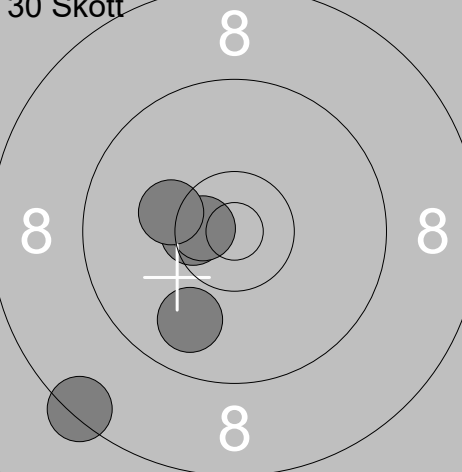
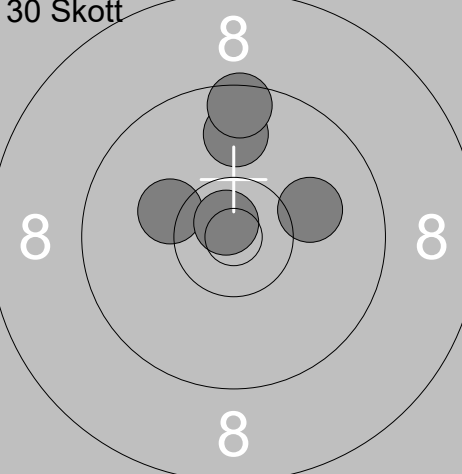
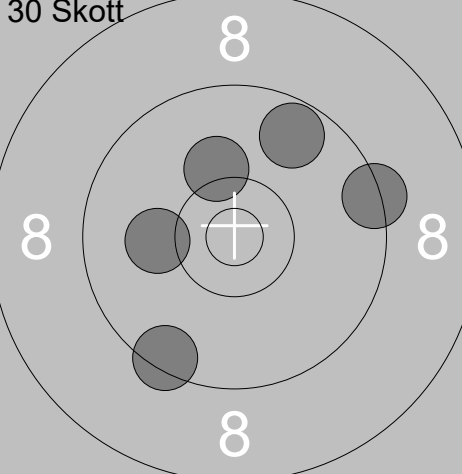
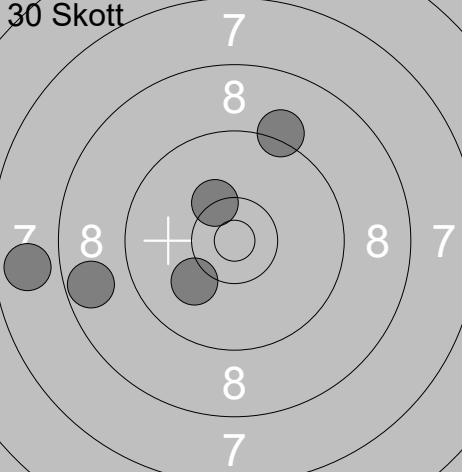
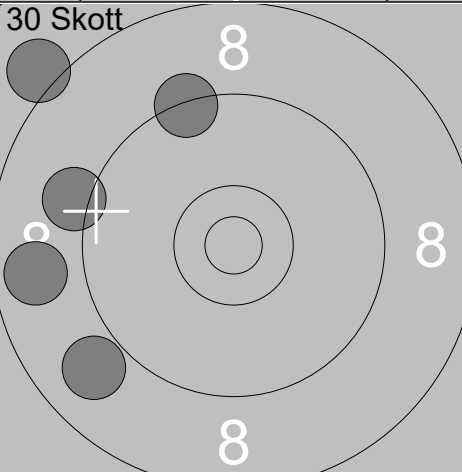
<p>Prov</p> 	<table border="1" style="width:100%; border-collapse: collapse;"> <tr><td>1:</td><td>9.2</td><td>↖</td></tr> <tr><td>2:</td><td>10.4x</td><td>↘</td></tr> <tr><td>3:</td><td>10.3x</td><td>↖</td></tr> <tr><td>4:</td><td>8.3</td><td>↑</td></tr> <tr><td>5:</td><td>10.9x</td><td>↑</td></tr> <tr><td>6:</td><td>10.0</td><td>↘</td></tr> <tr><td>7:</td><td>9.8</td><td>↑</td></tr> <tr><td>8:</td><td>10.5x</td><td>↘</td></tr> <tr><td>9:</td><td>9.6</td><td>↗</td></tr> <tr><td>10:</td><td>10.4x</td><td>↑</td></tr> <tr><td colspan="2">Serie</td><td>95</td></tr> <tr><td colspan="2">Total</td><td>0</td></tr> </table>	1:	9.2	↖	2:	10.4x	↘	3:	10.3x	↖	4:	8.3	↑	5:	10.9x	↑	6:	10.0	↘	7:	9.8	↑	8:	10.5x	↘	9:	9.6	↗	10:	10.4x	↑	Serie		95	Total		0	<p>Prov</p>  <table border="1" style="width:100%; border-collapse: collapse;"> <tr><td>11:</td><td>8.9</td><td>↖</td></tr> <tr><td>12:</td><td>10.3x</td><td>→</td></tr> <tr><td>13:</td><td>10.1</td><td>↑</td></tr> <tr><td>14:</td><td>10.1</td><td>↘</td></tr> <tr><td colspan="2">Serie</td><td>38</td></tr> <tr><td colspan="2">Total</td><td>0</td></tr> </table>	11:	8.9	↖	12:	10.3x	→	13:	10.1	↑	14:	10.1	↘	Serie		38	Total		0
1:	9.2	↖																																																						
2:	10.4x	↘																																																						
3:	10.3x	↖																																																						
4:	8.3	↑																																																						
5:	10.9x	↑																																																						
6:	10.0	↘																																																						
7:	9.8	↑																																																						
8:	10.5x	↘																																																						
9:	9.6	↗																																																						
10:	10.4x	↑																																																						
Serie		95																																																						
Total		0																																																						
11:	8.9	↖																																																						
12:	10.3x	→																																																						
13:	10.1	↑																																																						
14:	10.1	↘																																																						
Serie		38																																																						
Total		0																																																						
<p>30 Skott</p> 	<table border="1" style="width:100%; border-collapse: collapse;"> <tr><td>1:</td><td>10.0</td><td>↘</td></tr> <tr><td>2:</td><td>10.3</td><td>↗</td></tr> <tr><td>3:</td><td>9.8</td><td>↘</td></tr> <tr><td>4:</td><td>10.1</td><td>↘</td></tr> <tr><td>5:</td><td>9.8</td><td>←</td></tr> <tr><td colspan="2">Serie</td><td>48</td></tr> <tr><td colspan="2">Total</td><td>48</td></tr> </table>	1:	10.0	↘	2:	10.3	↗	3:	9.8	↘	4:	10.1	↘	5:	9.8	←	Serie		48	Total		48	 <table border="1" style="width:100%; border-collapse: collapse;"> <tr><td>6:</td><td>9.6</td><td>↑</td></tr> <tr><td>7:</td><td>8.1</td><td>↗</td></tr> <tr><td>8:</td><td>9.8</td><td>↑</td></tr> <tr><td>9:</td><td>10.6x</td><td>↗</td></tr> <tr><td>10:</td><td>9.1</td><td>↗</td></tr> <tr><td colspan="2">Serie</td><td>45</td></tr> <tr><td colspan="2">Total</td><td>93</td></tr> </table>	6:	9.6	↑	7:	8.1	↗	8:	9.8	↑	9:	10.6x	↗	10:	9.1	↗	Serie		45	Total		93												
1:	10.0	↘																																																						
2:	10.3	↗																																																						
3:	9.8	↘																																																						
4:	10.1	↘																																																						
5:	9.8	←																																																						
Serie		48																																																						
Total		48																																																						
6:	9.6	↑																																																						
7:	8.1	↗																																																						
8:	9.8	↑																																																						
9:	10.6x	↗																																																						
10:	9.1	↗																																																						
Serie		45																																																						
Total		93																																																						
<p>30 Skott</p> 	<table border="1" style="width:100%; border-collapse: collapse;"> <tr><td>11:</td><td>9.7</td><td>↘</td></tr> <tr><td>12:</td><td>8.5</td><td>↘</td></tr> <tr><td>13:</td><td>9.9</td><td>←</td></tr> <tr><td>14:</td><td>9.3</td><td>→</td></tr> <tr><td>15:</td><td>9.6</td><td>↗</td></tr> <tr><td colspan="2">Serie</td><td>44</td></tr> <tr><td colspan="2">Total</td><td>137</td></tr> </table>	11:	9.7	↘	12:	8.5	↘	13:	9.9	←	14:	9.3	→	15:	9.6	↗	Serie		44	Total		137	<p>30 Skott</p>  <table border="1" style="width:100%; border-collapse: collapse;"> <tr><td>16:</td><td>9.1</td><td>→</td></tr> <tr><td>17:</td><td>8.1</td><td>→</td></tr> <tr><td>18:</td><td>10.1</td><td>↘</td></tr> <tr><td>19:</td><td>8.9</td><td>→</td></tr> <tr><td>20:</td><td>8.5</td><td>↖</td></tr> <tr><td colspan="2">Serie</td><td>43</td></tr> <tr><td colspan="2">Total</td><td>180</td></tr> </table>	16:	9.1	→	17:	8.1	→	18:	10.1	↘	19:	8.9	→	20:	8.5	↖	Serie		43	Total		180												
11:	9.7	↘																																																						
12:	8.5	↘																																																						
13:	9.9	←																																																						
14:	9.3	→																																																						
15:	9.6	↗																																																						
Serie		44																																																						
Total		137																																																						
16:	9.1	→																																																						
17:	8.1	→																																																						
18:	10.1	↘																																																						
19:	8.9	→																																																						
20:	8.5	↖																																																						
Serie		43																																																						
Total		180																																																						
<p>30 Skott</p> 	<table border="1" style="width:100%; border-collapse: collapse;"> <tr><td>21:</td><td>9.4</td><td>→</td></tr> <tr><td>22:</td><td>10.3</td><td>↘</td></tr> <tr><td>23:</td><td>9.2</td><td>↑</td></tr> <tr><td>24:</td><td>9.9</td><td>↑</td></tr> <tr><td>25:</td><td>9.3</td><td>↗</td></tr> <tr><td colspan="2">Serie</td><td>46</td></tr> <tr><td colspan="2">Total</td><td>226</td></tr> </table>	21:	9.4	→	22:	10.3	↘	23:	9.2	↑	24:	9.9	↑	25:	9.3	↗	Serie		46	Total		226	<p>30 Skott</p>  <table border="1" style="width:100%; border-collapse: collapse;"> <tr><td>26:</td><td>9.0</td><td>↑</td></tr> <tr><td>27:</td><td>9.2</td><td>↗</td></tr> <tr><td>28:</td><td>9.6</td><td>↘</td></tr> <tr><td>29:</td><td>8.5</td><td>↖</td></tr> <tr><td>30:</td><td>9.0</td><td>↑</td></tr> <tr><td colspan="2">Serie</td><td>44</td></tr> <tr><td colspan="2">Total</td><td>270</td></tr> </table>	26:	9.0	↑	27:	9.2	↗	28:	9.6	↘	29:	8.5	↖	30:	9.0	↑	Serie		44	Total		270												
21:	9.4	→																																																						
22:	10.3	↘																																																						
23:	9.2	↑																																																						
24:	9.9	↑																																																						
25:	9.3	↗																																																						
Serie		46																																																						
Total		226																																																						
26:	9.0	↑																																																						
27:	9.2	↗																																																						
28:	9.6	↘																																																						
29:	8.5	↖																																																						
30:	9.0	↑																																																						
Serie		44																																																						
Total		270																																																						

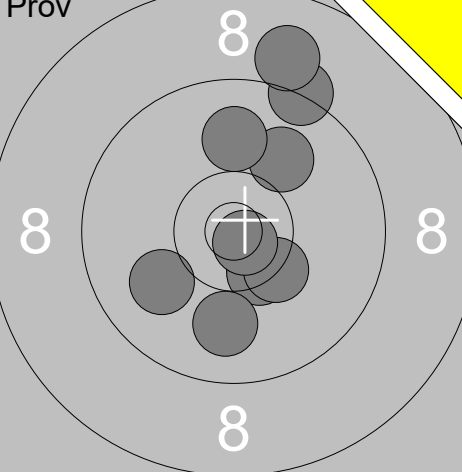
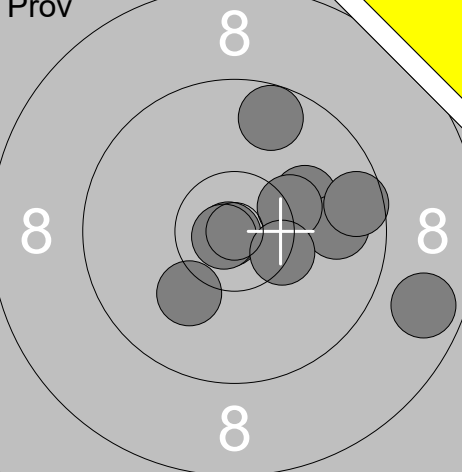
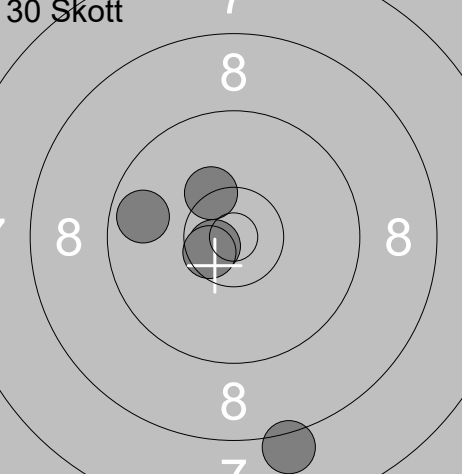
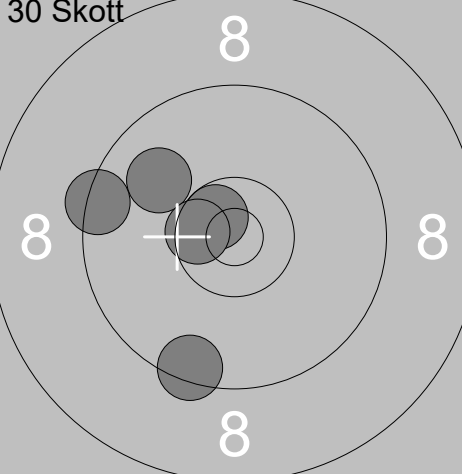
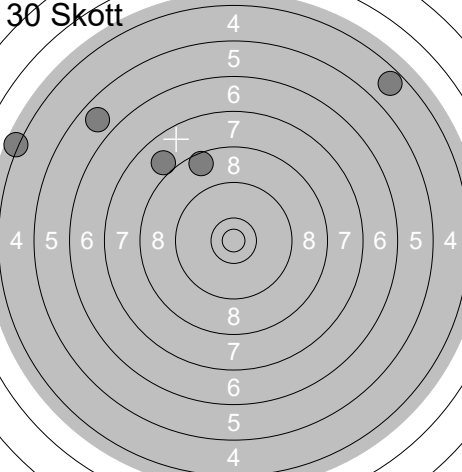
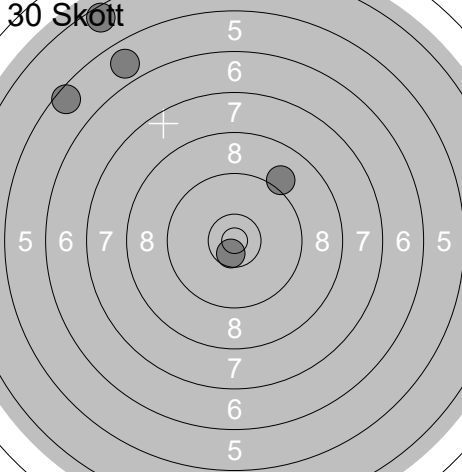
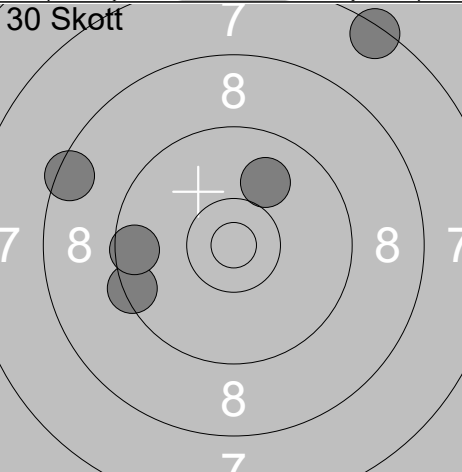
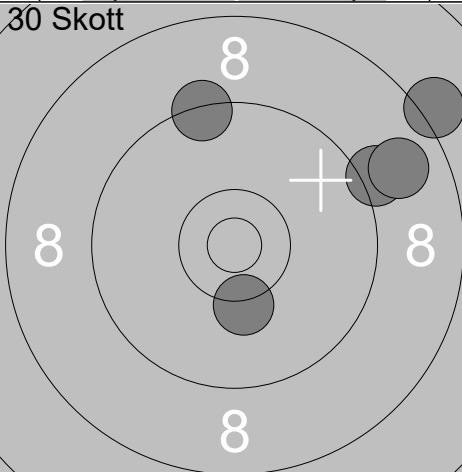
 <p>7 8 8 7 8</p>	<p>1: 7.8 ↘ 2: 8.0 ↓ 3: 9.5 ↗ 4: 10.3x ↗ 5: 9.7 ↗ 6: 9.1 ↗ 7: 10.5x → 8: 10.5x →</p> <p>Serie 72 Total 0</p>	<p>30 Skott</p>  <p>8 8 8</p> <p>6: 10.1 → 7: 10.2 ↗ 8: 10.8x ↗ 9: 9.8 ↑ 10: 9.5 ↑</p> <p>Serie 48 Total 95</p>	<p>1: 10.5x ← 2: 9.9 ↓ 3: 8.4 ↓ 4: 10.6x ← 5: 10.2 ←</p> <p>Serie 47 Total 47</p>
<p>30 Skott</p>  <p>8 8 8</p> <p>11: 9.4 → 12: 9.4 ↓ 13: 10.1 ← 14: 9.7 ↗ 15: 10.2 ↑</p> <p>Serie 48 Total 95</p>	<p>30 Skott</p>  <p>8 8 8</p> <p>16: 8.9 ← 17: 8.6 ← 18: 10.1 → 19: 8.1 ← 20: 8.2 ←</p> <p>Serie 42 Total 184</p>	<p>11: 9.4 → 12: 9.4 ↓ 13: 10.1 ← 14: 9.7 ↗ 15: 10.2 ↑</p> <p>Serie 47 Total 142</p>	<p>30 Skott</p>  <p>7 8 8 7 8 7</p> <p>21: 9.2 ↑ 22: 7.8 ← 23: 8.7 ← 24: 10.3x ↗ 25: 10.1 ↓</p> <p>Serie 44 Total 228</p>
<p>30 Skott</p>  <p>8 8 8</p> <p>26: 8.8 ← 27: 8.1 ↗ 28: 8.9 ↓ 29: 9.3 ↗ 30: 9.1 ←</p> <p>Serie 42 Total 270</p>			

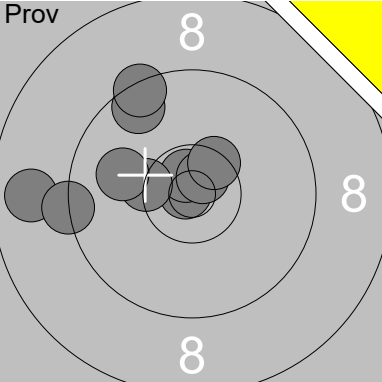
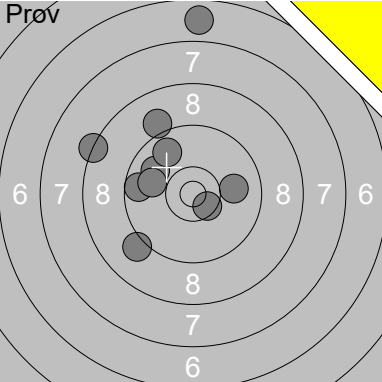
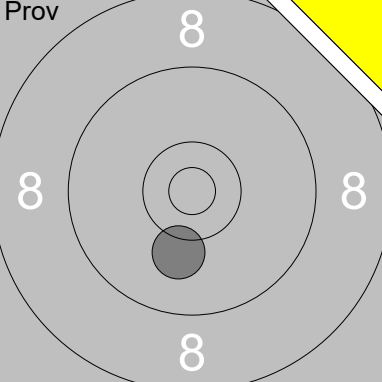
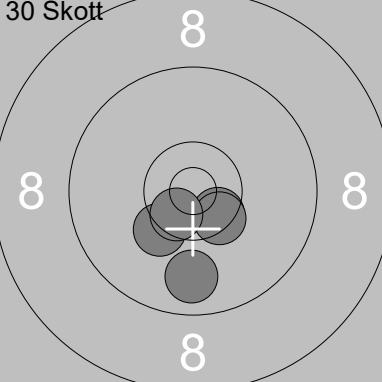
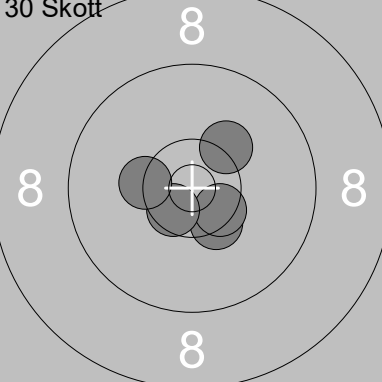
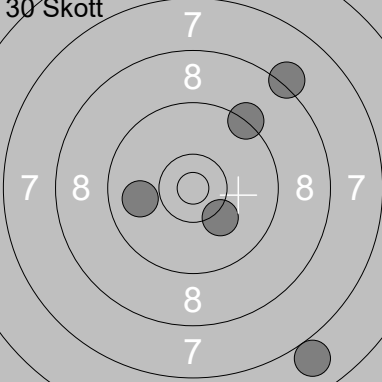
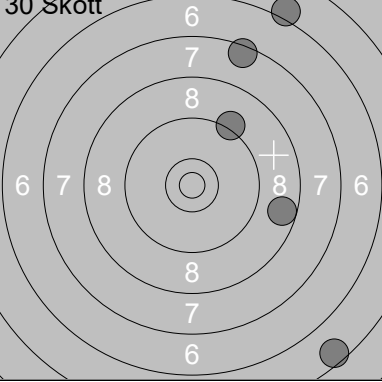
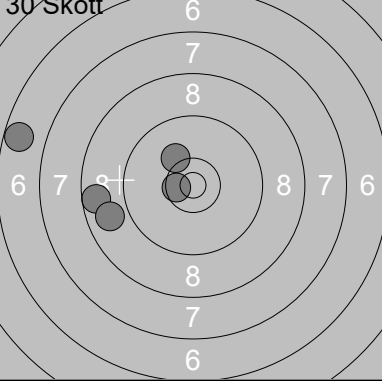
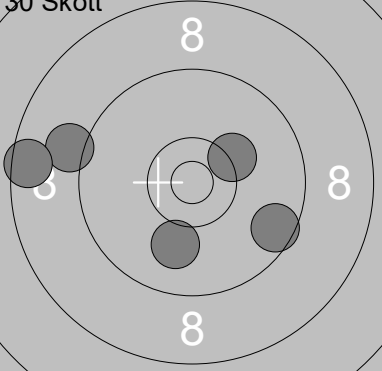
Prov 	1: 9.3 ↗ 2: 9.0 ↗ 3: 10.5x ↘ 4: 10.4x ↘ 5: 10.0 ↗ 6: 9.9 ↘ 7: 9.9 ↗ 8: 10.0 ↖ 9: 10.3x ↘ 10: 10.8x ↘ <hr/> Serie 96 Total 0	Prov 	11: 10.9x ↖ 12: 10.1 ↗ 13: 9.8 → 14: 9.6 → 15: 8.7 → 16: 10.8x ↖ 17: 10.3x ↗ 18: 10.1 ↘ 19: 9.7 ↗ 20: 10.4x ↘ <hr/> Serie 95 Total 0
30 Skott 	1: 10.7x ↖ 2: 10.3x ↗ 3: 8.1 ↘ 4: 10.6x ↖ 5: 9.7 ↖ <hr/> Serie 47 Total 47	30 Skott 	6: 9.4 ↘ 7: 9.9 ↗ 8: 10.7x ↗ 9: 10.5x ↖ 10: 9.4 ↖ <hr/> Serie 47 Total 94
30 Skott 	11: 8.0 ↗ 12: 4.2 ↖ 13: 4.7 ↗ 14: 5.8 ↗ 15: 8.6 ↗ <hr/> Serie 29 Total 123	30 Skott 	16: 5.8 ↗ 17: 5.5 ↗ 18: 9.1 ↗ 19: 4.6 ↗ 20: 10.6x ↘ <hr/> Serie 33 Total 156
30 Skott 	21: 9.4 ↖ 22: 10.0 ↗ 23: 7.4 ↗ 24: 8.5 ↖ 25: 9.6 ↖ <hr/> Serie 43 Total 199	30 Skott 	26: 9.1 ↗ 27: 8.1 ↗ 28: 8.9 ↗ 29: 10.2 ↘ 30: 9.4 ↗ <hr/> Serie 44 Total 243

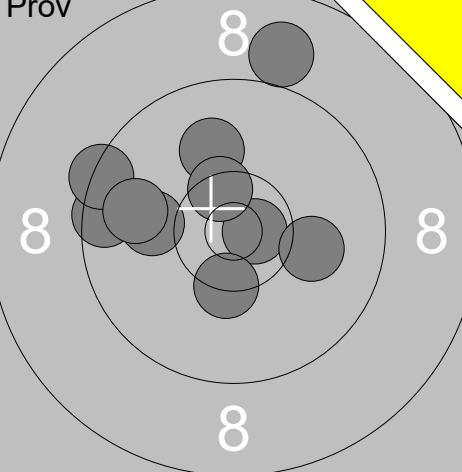
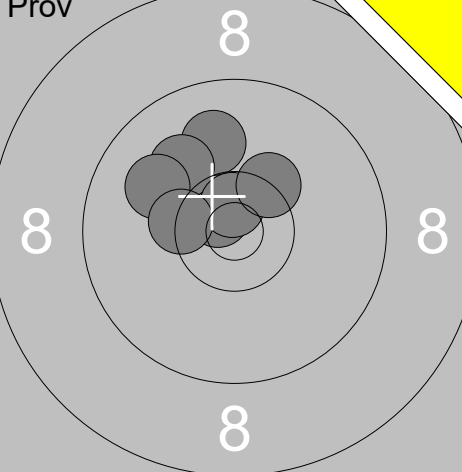
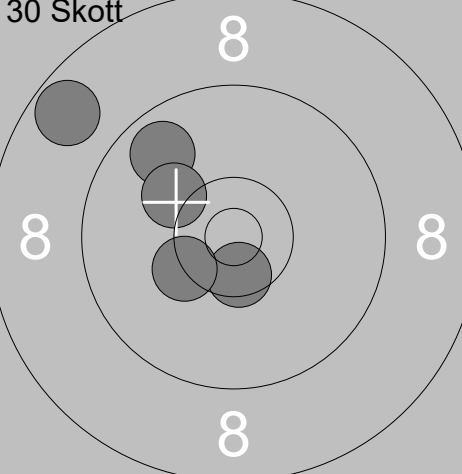
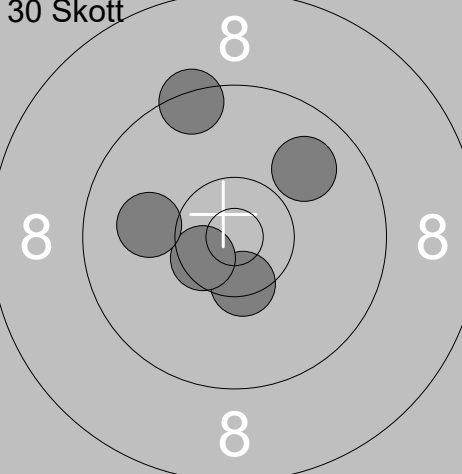
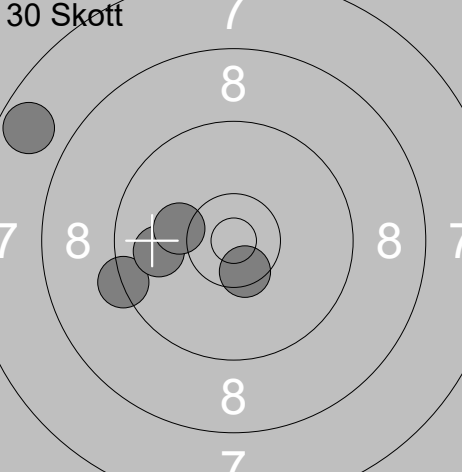
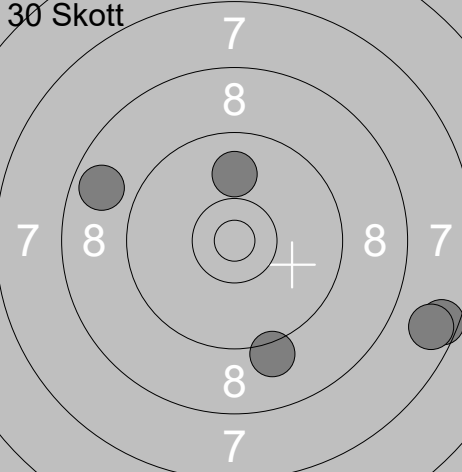
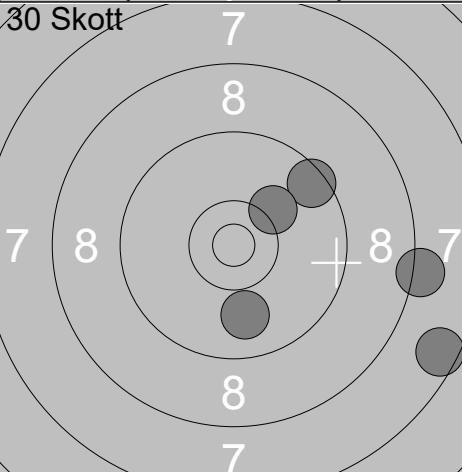
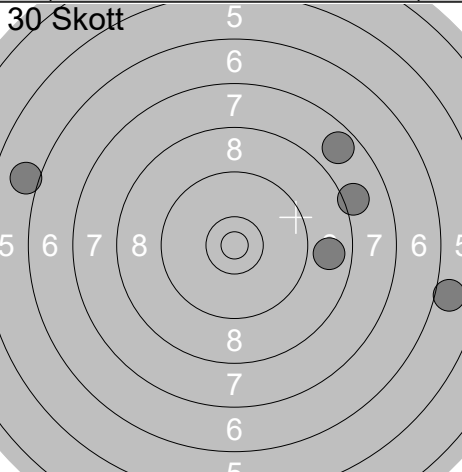
Skjuttag 4	Tavla 12	Hanna Johansson			
Ramselefors		Umeå		Vb	
28.04.2019		Vindelnskottet 2019		Ramselefors SKF	
Prov 	1: 10.9x 2: 10.7x 3: 9.6 4: 10.7x 5: 10.3x 6: 9.4 7: 10.0 8: 8.8 9: 10.4x 10: 9.3	← ↑ ↑ ↗ ← ↑ ← ← ↗ ←	Prov 	11: 6.8 12: 9.1 13: 10.0 14: 9.9 15: 9.8 16: 9.1 17: 9.6 18: 8.3 19: 10.5x 20: 9.9	↑ ↗ → ↗ ↗ ↘ ← ↗ ↘ ←
Serie 95		Total 0		Serie 88	
Total 0		Total 0		Total 0	
Prov 	21: 10.1	↓	30 Skott 	1: 9.8 2: 10.5x 3: 10.3 4: 10.4x 5: 10.6x	↓ ↘ ↘ ↘ ↘
Serie 10		Total 0		Serie 49	
Total 0		Total 49		Total 49	
30 Skott 	6: 10.4x 7: 10.5x 8: 10.6x 9: 10.2 10: 10.3x	↘ ↘ ↘ ↗ ←	30 Skott 	11: 6.9 12: 9.3 13: 9.9 14: 8.2 15: 10.2	↘ ↗ ← ↗ ↘
Serie 50		Total 99		Serie 42	
Total 99		Total 141		Total 141	
30 Skott 	16: 5.6 17: 9.2 18: 8.7 19: 6.1 20: 7.5	↘ ↗ → ↗ ↑	30 Skott 	21: 6.7 22: 10.6x 23: 8.6 24: 8.8 25: 10.2	← ← ← ← ↗
Serie 35		Total 176		Serie 42	
Total 176		Total 218		Total 218	
30 Skott 	26: 10.3 27: 9.1 28: 8.5 29: 10.0 30: 9.6	↗ ← ← ↘ ↘			
Serie 46		Total 264			
Total 264					

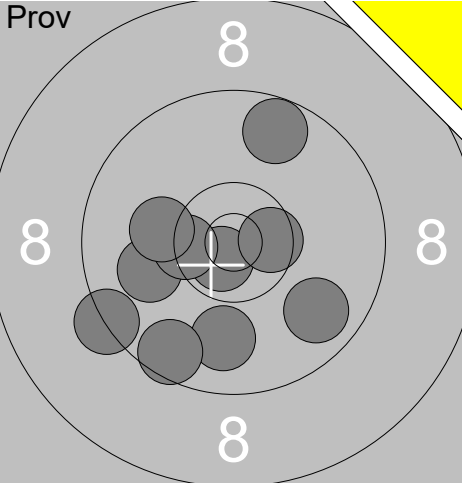
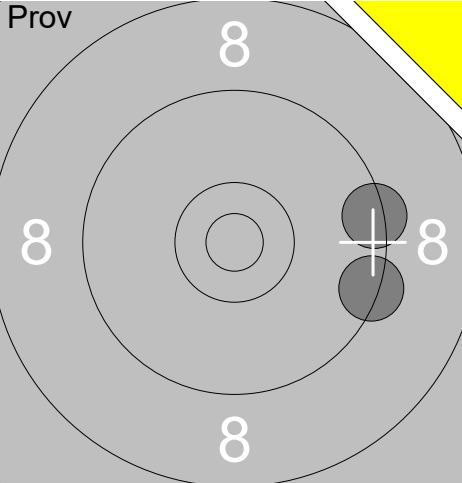
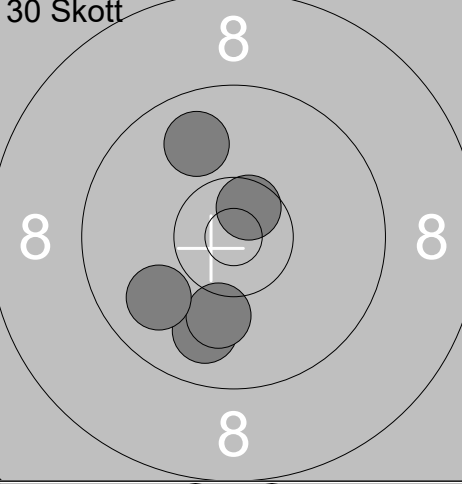
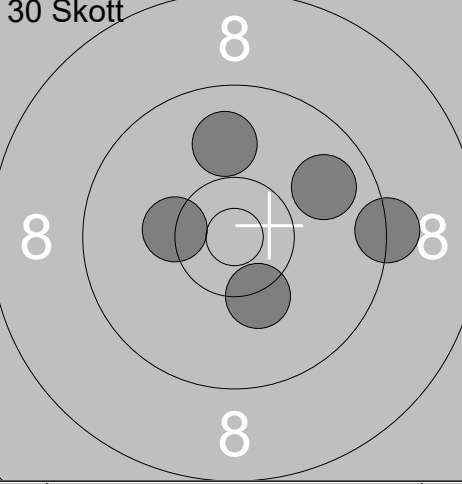
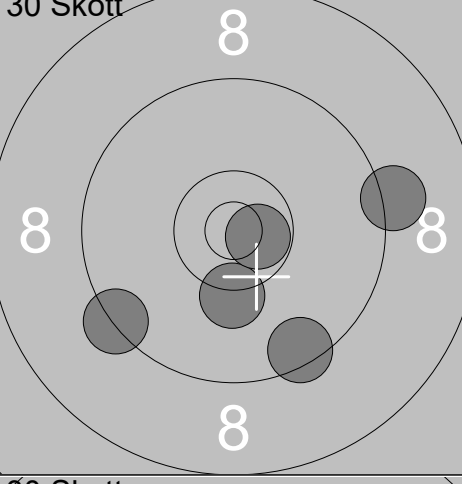
<p>Prov</p>  <p style="text-align: center;">8</p>	<p>1: 10.7x →</p> <p>2: 9.5 ←</p> <p>3: 10.4x ↓</p> <p>4: 9.4 ↗</p> <p>5: 10.0 ↗</p> <p>6: 10.5x ↗</p> <p>7: 10.1 ←</p> <p>8: 10.1 →</p> <p>9: 9.0 ↗</p> <p>10: 9.9 ←</p> <hr/> <p>Serie 96</p> <p>Total 0</p>	<p>Prov</p>  <p style="text-align: center;">8</p>	<p>11: 10.7x ↖</p> <p>12: 10.0 ↗</p> <p>13: 10.1 ↗</p> <p>14: 10.7x ↗</p> <p>15: 10.0 ↖</p> <p>16: 10.4x ←</p> <p>17: 10.3x ↗</p> <hr/> <p>Serie 70</p> <p>Total 0</p>
<p>30 Skott</p>  <p style="text-align: center;">8</p>	<p>1: 9.8 ↗</p> <p>2: 10.5x ↓</p> <p>3: 10.3x ←</p> <p>4: 8.7 ↗</p> <p>5: 10.2 ↗</p> <hr/> <p>Serie 47</p> <p>Total 47</p>	<p>30 Skott</p>  <p style="text-align: center;">8</p>	<p>6: 9.4 ↗</p> <p>7: 10.4x ↓</p> <p>8: 10.5x ←</p> <p>9: 9.9 ↗</p> <p>10: 10.0 ←</p> <hr/> <p>Serie 48</p> <p>Total 95</p>
<p>30 Skott</p>  <p style="text-align: center;">7</p>	<p>11: 7.7 ↖</p> <p>12: 9.3 ←</p> <p>13: 9.9 ←</p> <p>14: 10.2 ←</p> <p>15: 10.5x ↓</p> <hr/> <p>Serie 45</p> <p>Total 140</p>	<p>30 Skott</p>  <p style="text-align: center;">7</p>	<p>16: 7.5 →</p> <p>17: 8.8 ←</p> <p>18: 9.1 ↓</p> <p>19: 7.7 →</p> <p>20: 9.9 ↗</p> <hr/> <p>Serie 40</p> <p>Total 180</p>
<p>30 Skott</p>  <p style="text-align: center;">7</p>	<p>21: 9.9 ↓</p> <p>22: 8.2 →</p> <p>23: 9.5 ↗</p> <p>24: 10.2 ↗</p> <p>25: 7.6 →</p> <hr/> <p>Serie 43</p> <p>Total 223</p>	<p>30 Skott</p>  <p style="text-align: center;">5</p>	<p>26: 6.0 ←</p> <p>27: 7.7 ↗</p> <p>28: 8.1 →</p> <p>29: 6.0 →</p> <p>30: 8.8 →</p> <hr/> <p>Serie 35</p> <p>Total 258</p>

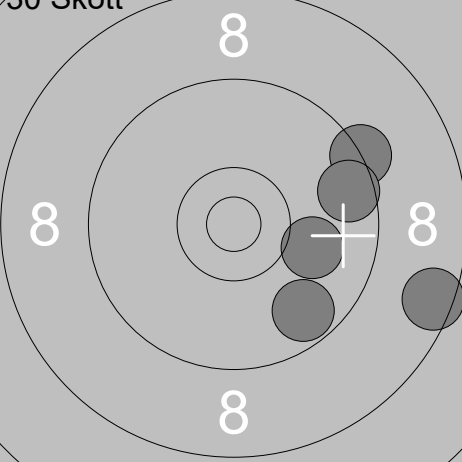
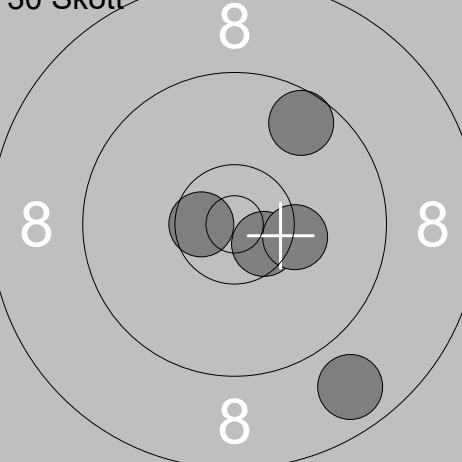
Skjutlag 4	Tavla 14	Lars Möllsten	
Ramselefors	Umeå		Vb
28.04.2019	Vindelnskottet 2019	Ramselefors SKF	
Prov 	1: 9.3 ↙ 2: 9.8 ↘ 3: 9.9 ↓ 4: 10.0 ← 5: 10.7x ↘ 6: 10.5x → 7: 10.4x ← 8: 9.6 ↓ 9: 10.2 ← 10: 9.7 ↑	Prov 	11: 9.4 → 12: 9.4 →
	Serie 95 Total 0		Serie 18 Total 0
30 Skott 	1: 9.9 ↓ 2: 10.6x ↗ 3: 10.1 ↓ 4: 9.9 ↙ 5: 9.9 ↗	30 Skott 	6: 9.8 ↗ 7: 9.9 ↑ 8: 9.3 → 9: 10.3 ↓ 10: 10.3x ←
	Serie 47 Total 47		Serie 47 Total 94
30 Skott 	11: 9.3 ↙ 12: 10.2 ↓ 13: 9.2 → 14: 9.5 ↘ 15: 10.7x →	30 Skott 	16: 9.5 ↗ 17: 10.8x ↑ 18: 7.7 ← 19: 7.7 ↗ 20: 8.8 ↘
	Serie 47 Total 141		Serie 41 Total 182
30 Skott 	21: 10.0 → 22: 9.7 ↘ 23: 9.3 ↗ 24: 9.6 → 25: 8.5 ↘	30 Skott 	26: 8.8 ↘ 27: 9.6 ↗ 28: 10.6x ↘ 29: 10.6x ← 30: 10.3 →
	Serie 45 Total 227		Serie 47 Total 274

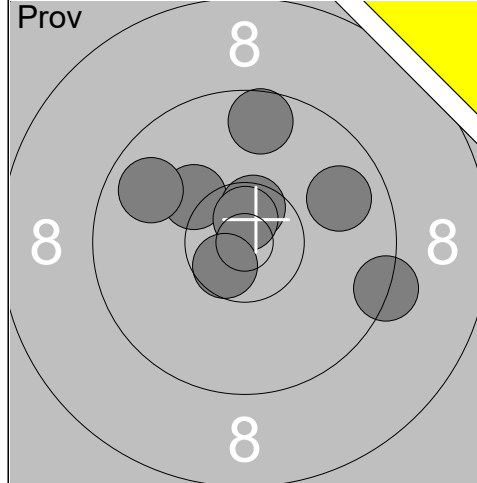

1:	10.2	↖
2:	10.6x	↑
3:	10.7x	↑
4:	9.8	→
5:	9.6	↑
6:	10.6x	↙
7:	9.3	→
8:	9.8	↖

Serie	76
Total	0

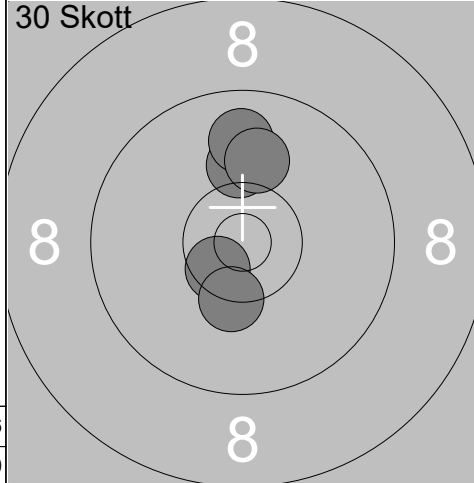

1:	10.1	↑
2:	9.8	↑
3:	10.6x	↙
4:	10.3x	↓
5:	10.1	↑

Serie	49
Total	49

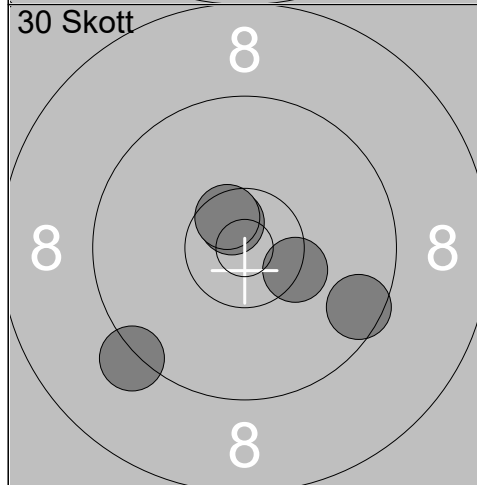

6:	9.6	↘
7:	10.6x	↖
8:	10.6x	↖
9:	9.2	↙
10:	10.3x	↘

Serie	48
Total	97

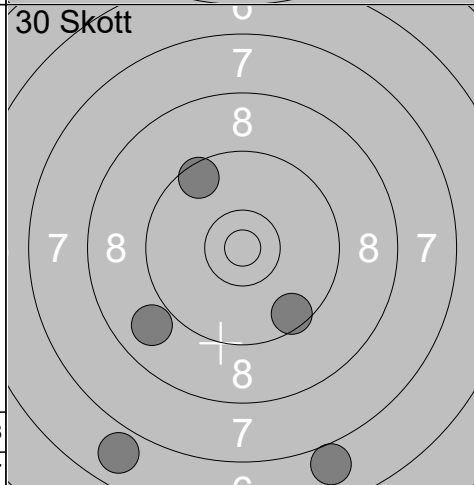

11:	6.9	↙
12:	9.5	↖
13:	7.0	↘
14:	8.9	↙
15:	9.5	↘

Serie	39
Total	136

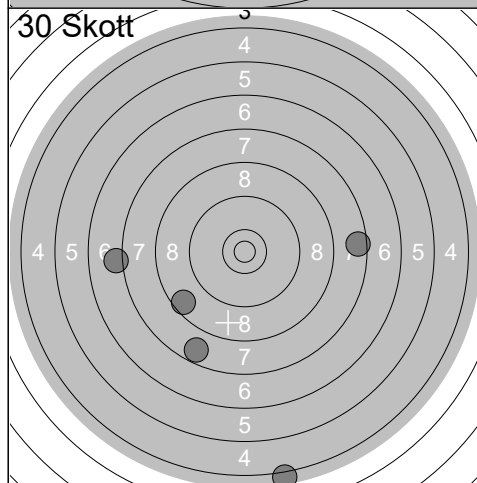

16:	7.1	←
17:	4.1	↓
18:	7.6	→
19:	7.7	↙
20:	8.6	↙

Serie	33
Total	169

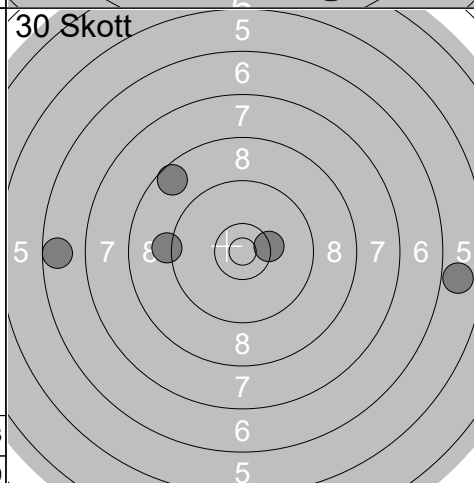

21:	8.6	↖
22:	10.3x	→
23:	9.2	←
24:	6.6	←
25:	5.9	→

Serie	38
Total	207

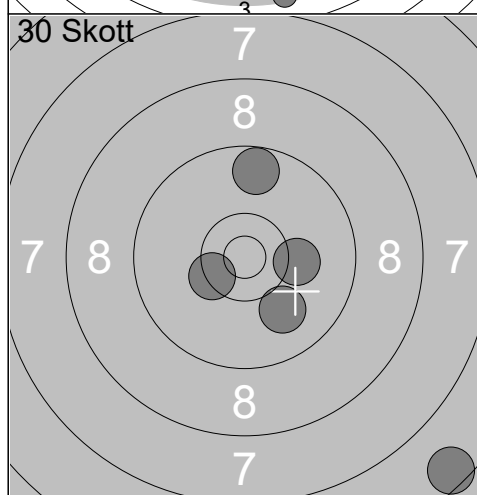

26:	9.7	↑
27:	10.4x	↙
28:	6.5	↘
29:	10.0	↘
30:	10.2	→

Serie	45
Total	252

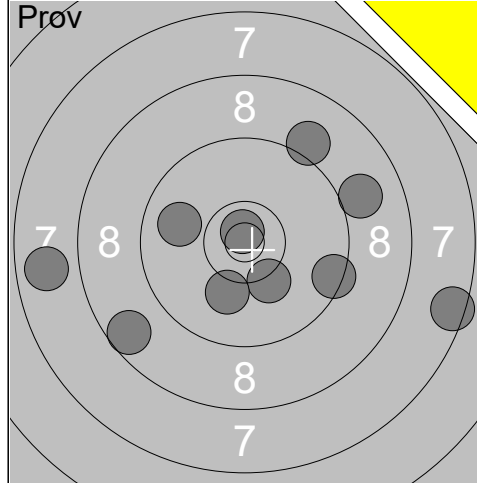

1:	8.6	↙
2:	7.5	→
3:	7.8	←
4:	9.1	↗
5:	9.4	→
6:	10.2	↘
7:	10.1	↘
8:	10.8x	↗
9:	9.0	→
10:	9.9	←

Serie	88
Total	0

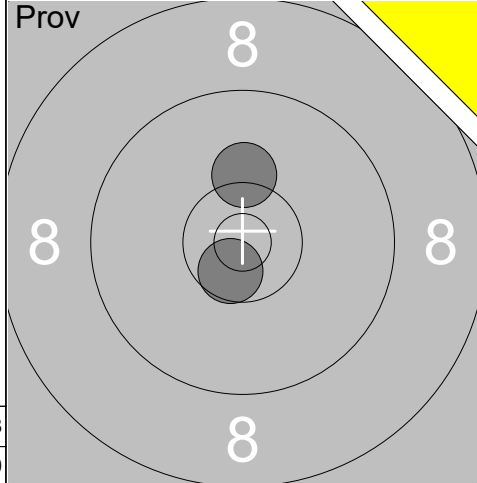

11:	10.2	↑
12:	10.6x	↘

Serie	20
Total	0

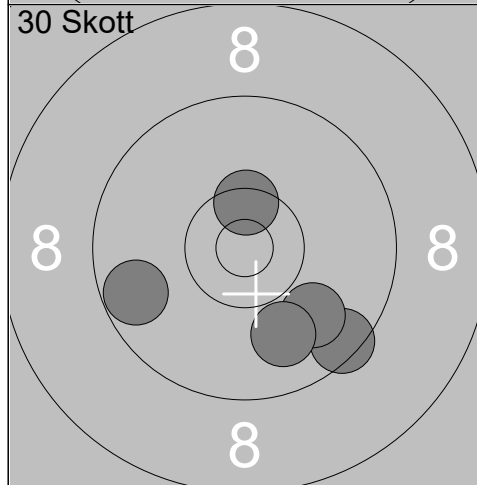

1:	9.5	↘
2:	9.7	←
3:	9.9	↘
4:	9.9	↘
5:	10.5x	↑

Serie	46
Total	46

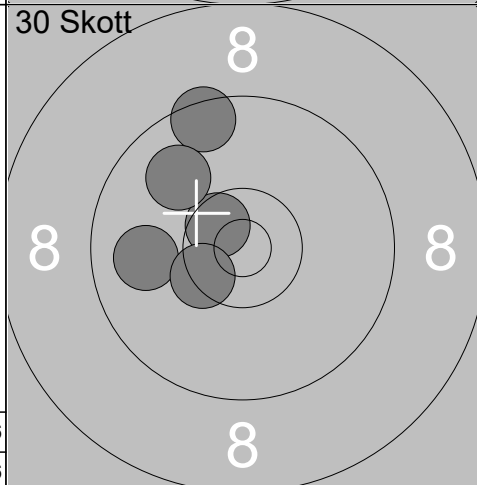

6:	10.6x	↗
7:	9.5	↗
8:	9.9	←
9:	9.9	↗
10:	10.4x	↙

Serie	47
Total	93

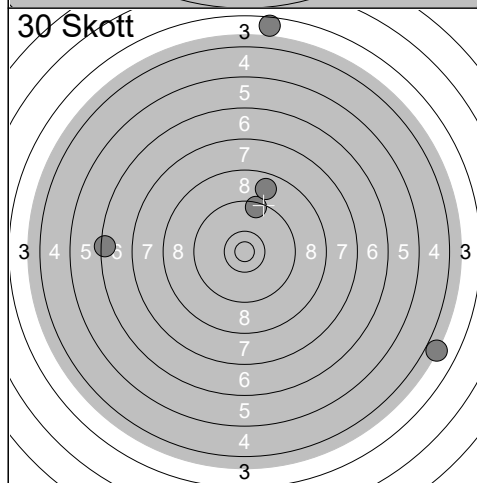

11:	3.9	↘
12:	6.4	←
13:	9.5	↑
14:	8.8	↑
15:	3.6	↑

Serie	29
Total	122

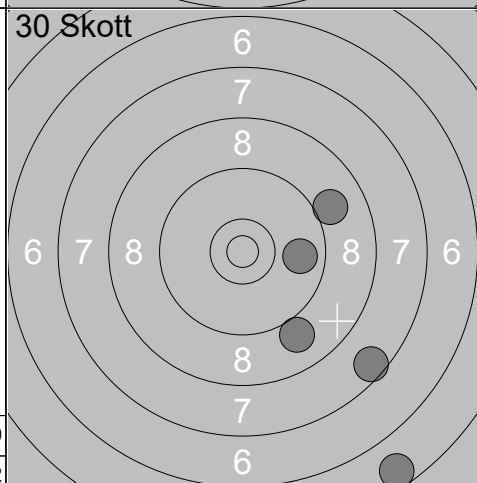

16:	9.0	↗
17:	5.6	↘
18:	9.8	→
19:	9.0	↘
20:	7.6	↘

Serie	39
Total	161

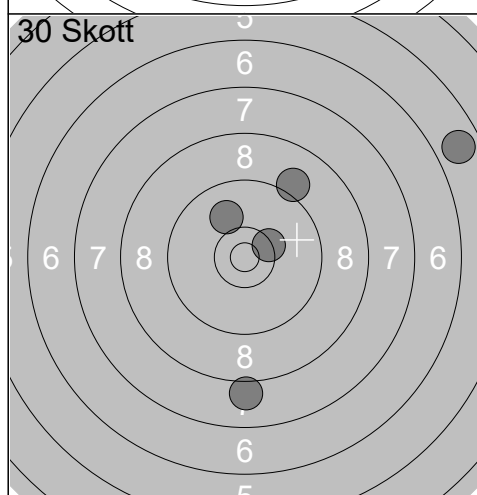

21:	10.4x	↗
22:	9.1	↗
23:	5.8	→
24:	10.0	↗
25:	8.0	↘

Serie	42
Total	203

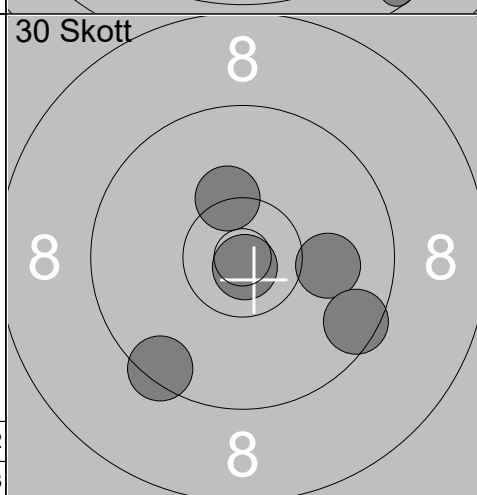

26:	10.3x	↑
27:	10.8x	↘
28:	9.4	↙
29:	10.0	→
30:	9.5	↘

Serie	48
Total	251