

1:	9.1	↘
2:	10.0	↙
3:	10.7x	↙
Serie		29.0
Total		241.0

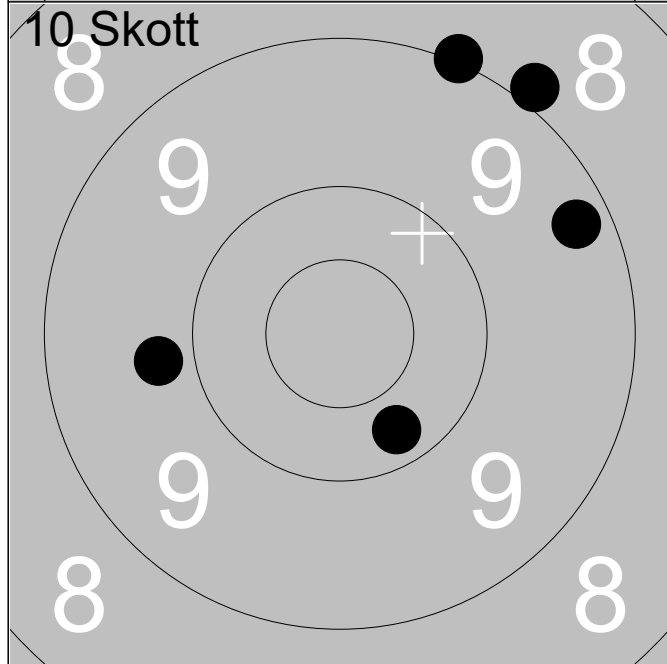

1:	9.3	→
2:	9.8	←
3:	9.0	↑
4:	8.9	↗
5:	10.2	↘
Serie		45.0
Total		286.0

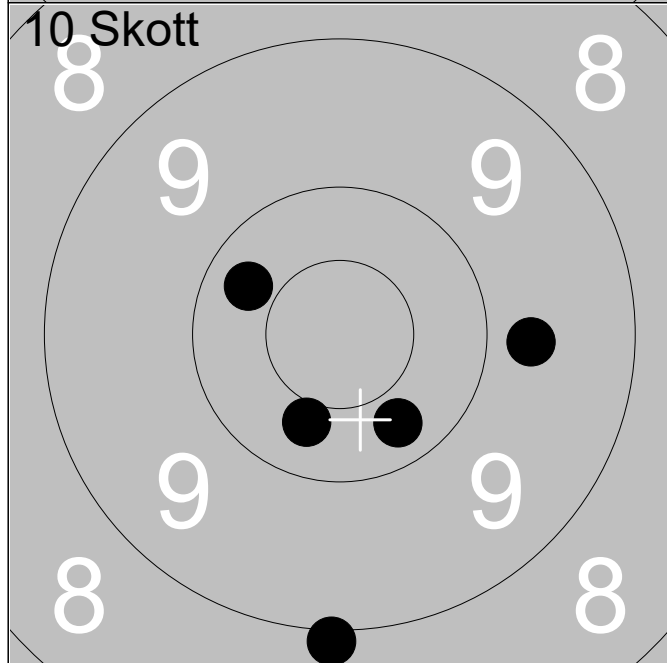

6:	10.3	↘
7:	9.7	→
8:	9.0	↘
9:	10.3	↗
10:	10.4	↘
Serie		48.0
Total		334.0

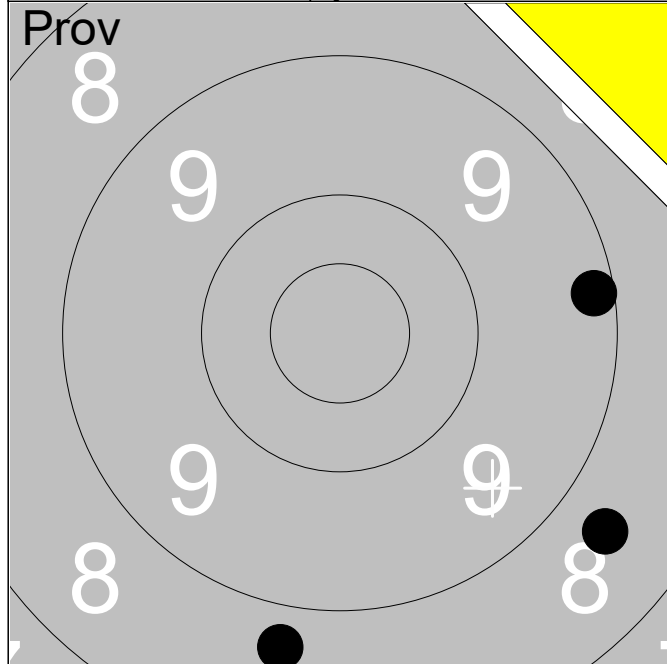

	1:	9.2	→
	2:	8.6	↘
	3:	8.7	↓
Serie			25.0
Total			240.0

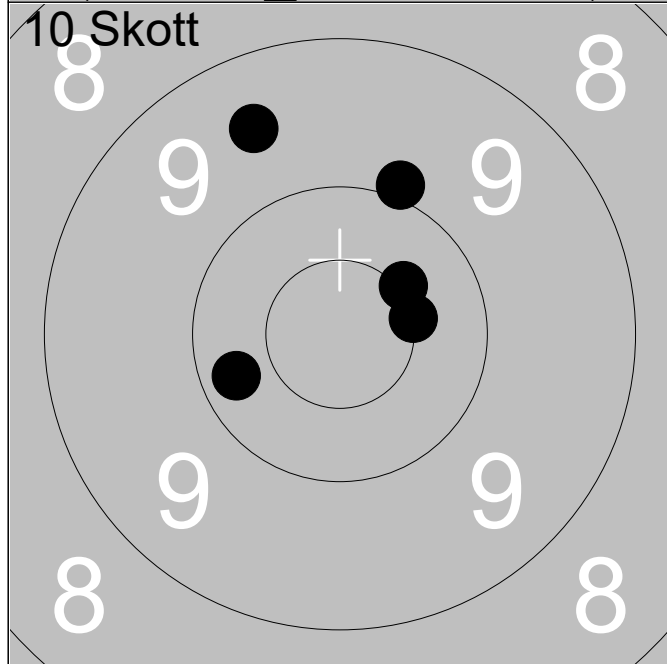

	1:	10.3	←
	2:	9.5	↑
	3:	9.9	↑
	4:	10.4x	↗
	5:	10.5x	→
Serie			48.0
Total			288.0

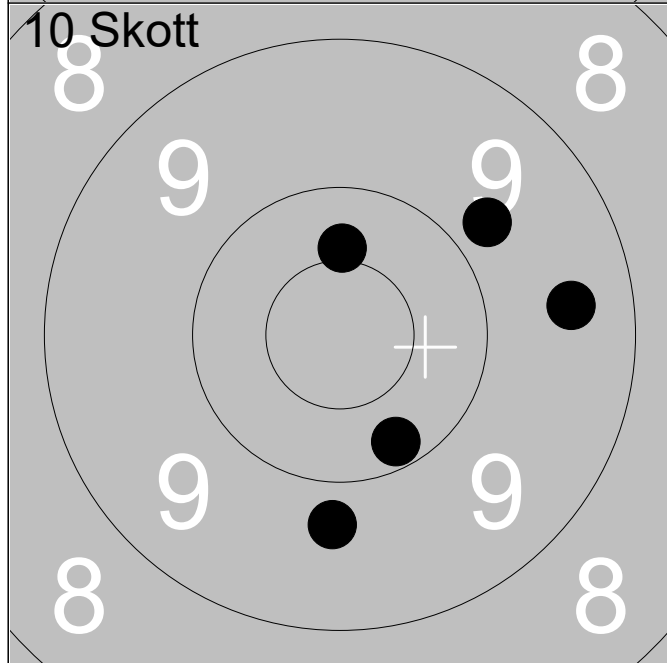

	6:	10.4	↑
	7:	9.8	↗
	8:	9.5	→
	9:	10.2	↓
	10:	9.7	↓
Serie			47.0
Total			335.0

13.07.2023	Björkskottet 2023	Ramselefors SKF
------------	-------------------	-----------------

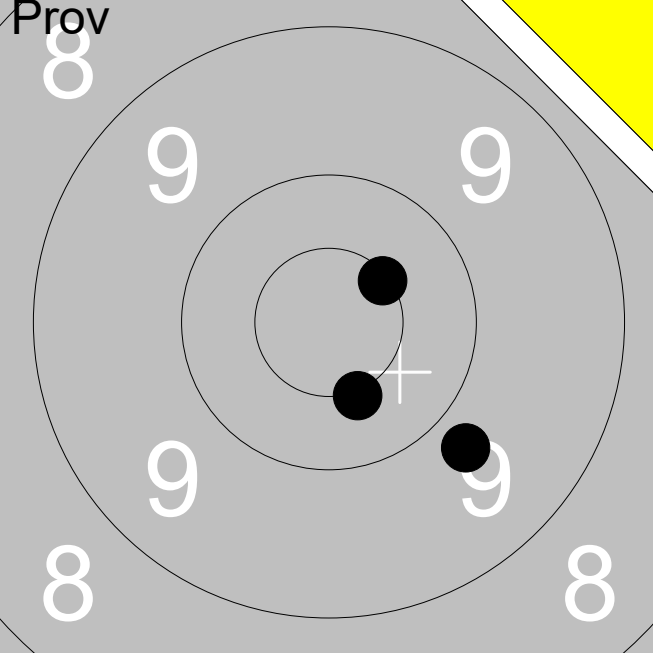
<div style="text-align: left; padding-left: 5px;">Prov</div> 	<table style="width:100%; border-collapse: collapse;"> <tr><td style="width:10%;">1:</td><td style="width:40%;">10.5x</td><td style="width:50%; text-align: right;">↗</td></tr> <tr><td>2:</td><td>9.8</td><td style="text-align: right;">↘</td></tr> <tr><td>3:</td><td>10.5x</td><td style="text-align: right;">↘</td></tr> </table>	1:	10.5x	↗	2:	9.8	↘	3:	10.5x	↘
1:	10.5x	↗								
2:	9.8	↘								
3:	10.5x	↘								
<table style="width:100%; border-collapse: collapse;"> <tr> <td style="width:45%;">Serie</td> <td style="width:55%; text-align: right;">29.0</td> </tr> </table>		Serie	29.0							
Serie	29.0									
<table style="width:100%; border-collapse: collapse;"> <tr> <td style="width:45%;">Total</td> <td style="width:55%; text-align: right;">238.0</td> </tr> </table>		Total	238.0							
Total	238.0									

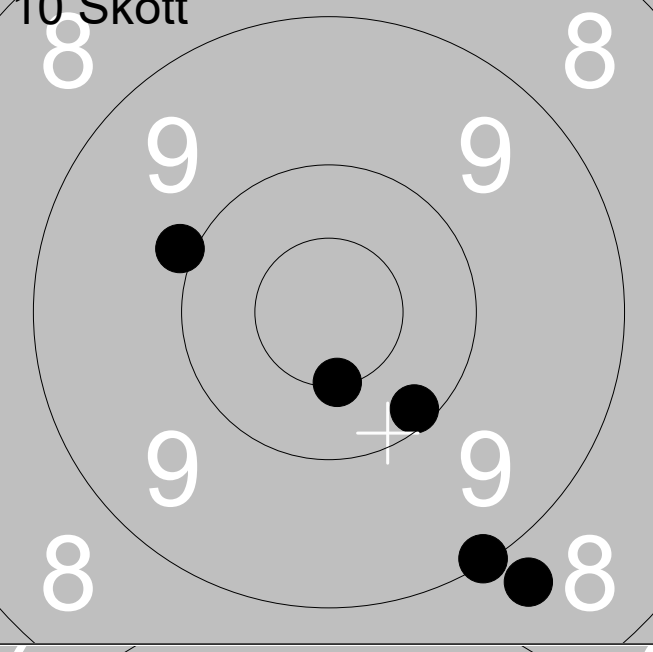
<div style="text-align: left; padding-left: 5px;">10 Skott</div> 	<table style="width:100%; border-collapse: collapse;"> <tr><td style="width:10%;">1:</td><td style="width:40%;">9.9</td><td style="width:50%; text-align: right;">↗</td></tr> <tr><td>2:</td><td>8.8</td><td style="text-align: right;">↘</td></tr> <tr><td>3:</td><td>10.5x</td><td style="text-align: right;">↘</td></tr> <tr><td>4:</td><td>9.1</td><td style="text-align: right;">↘</td></tr> <tr><td>5:</td><td>10.1</td><td style="text-align: right;">↘</td></tr> </table>	1:	9.9	↗	2:	8.8	↘	3:	10.5x	↘	4:	9.1	↘	5:	10.1	↘
1:	9.9	↗														
2:	8.8	↘														
3:	10.5x	↘														
4:	9.1	↘														
5:	10.1	↘														
<table style="width:100%; border-collapse: collapse;"> <tr> <td style="width:45%;">Serie</td> <td style="width:55%; text-align: right;">46.0</td> </tr> </table>		Serie	46.0													
Serie	46.0															
<table style="width:100%; border-collapse: collapse;"> <tr> <td style="width:45%;">Total</td> <td style="width:55%; text-align: right;">284.0</td> </tr> </table>		Total	284.0													
Total	284.0															

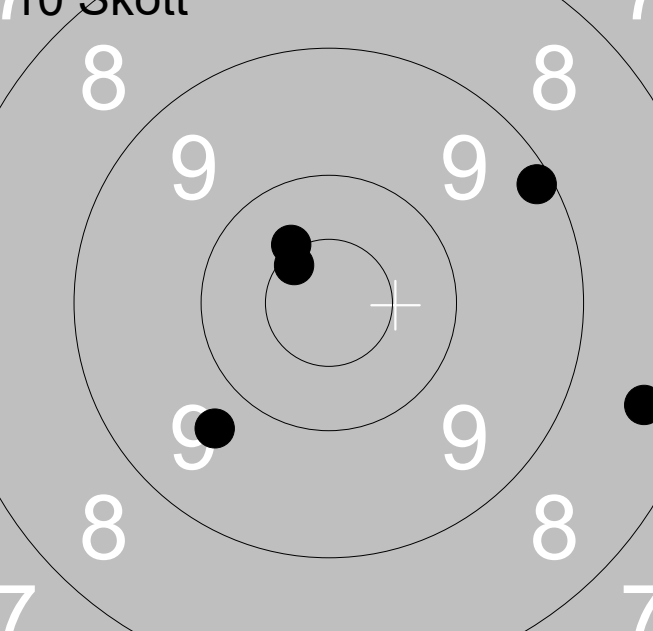
<div style="text-align: left; padding-left: 5px;">10 Skott</div> 	<table style="width:100%; border-collapse: collapse;"> <tr><td style="width:10%;">6:</td><td style="width:40%;">10.4x</td><td style="width:50%; text-align: right;">↗</td></tr> <tr><td>7:</td><td>10.6x</td><td style="text-align: right;">↗</td></tr> <tr><td>8:</td><td>8.4</td><td style="text-align: right;">↘</td></tr> <tr><td>9:</td><td>9.2</td><td style="text-align: right;">↗</td></tr> <tr><td>10:</td><td>9.7</td><td style="text-align: right;">↘</td></tr> </table>	6:	10.4x	↗	7:	10.6x	↗	8:	8.4	↘	9:	9.2	↗	10:	9.7	↘
6:	10.4x	↗														
7:	10.6x	↗														
8:	8.4	↘														
9:	9.2	↗														
10:	9.7	↘														
<table style="width:100%; border-collapse: collapse;"> <tr> <td style="width:45%;">Serie</td> <td style="width:55%; text-align: right;">46.0</td> </tr> </table>		Serie	46.0													
Serie	46.0															
<table style="width:100%; border-collapse: collapse;"> <tr> <td style="width:45%;">Total</td> <td style="width:55%; text-align: right;">330.0</td> </tr> </table>		Total	330.0													
Total	330.0															

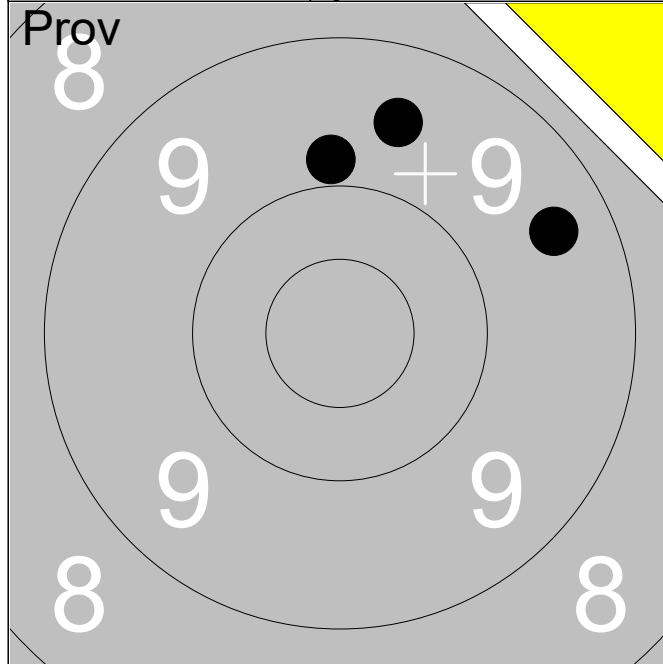

1:	9.4	→
2:	9.5	↑
3:	9.8	↑
Serie		27.0
Total		235.0

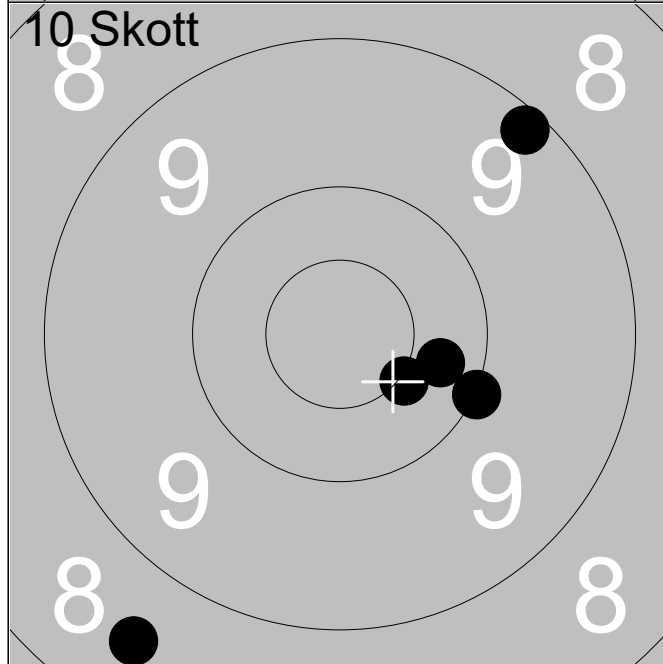

1:	8.5	↙
2:	10.3	→
3:	9.2	↗
4:	10.5x	↘
5:	10.0	→
Serie		47.0
Total		282.0

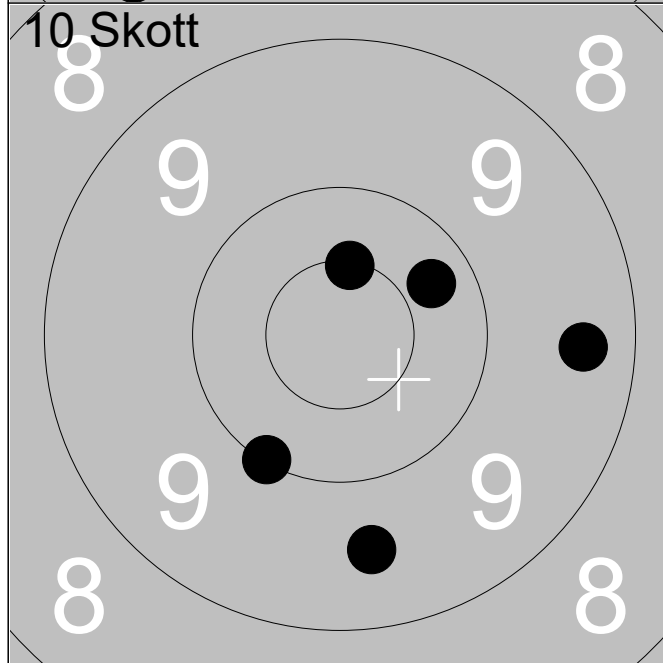

6:	10.0	↙
7:	10.5x	↑
8:	9.4	→
9:	10.3	↗
10:	9.6	↘
Serie		48.0
Total		330.0

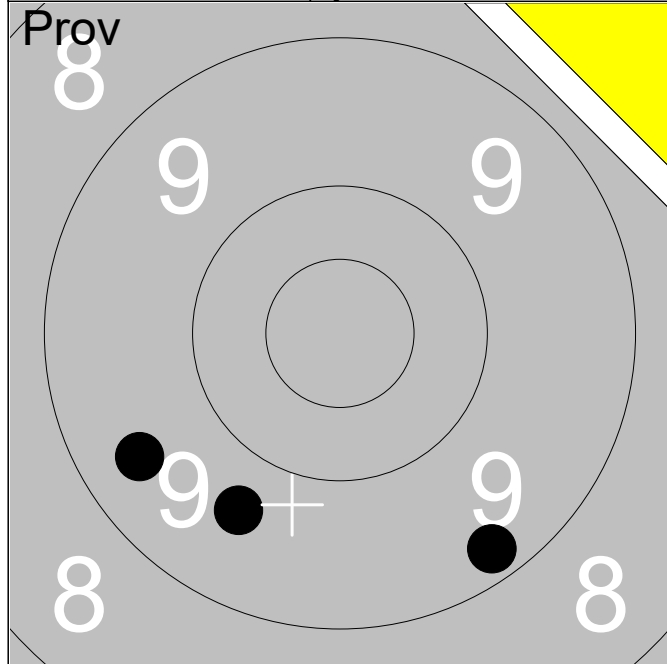

1:	9.4	↙
2:	9.7	↙
3:	9.2	↘
Serie		27.0
Total		231.0

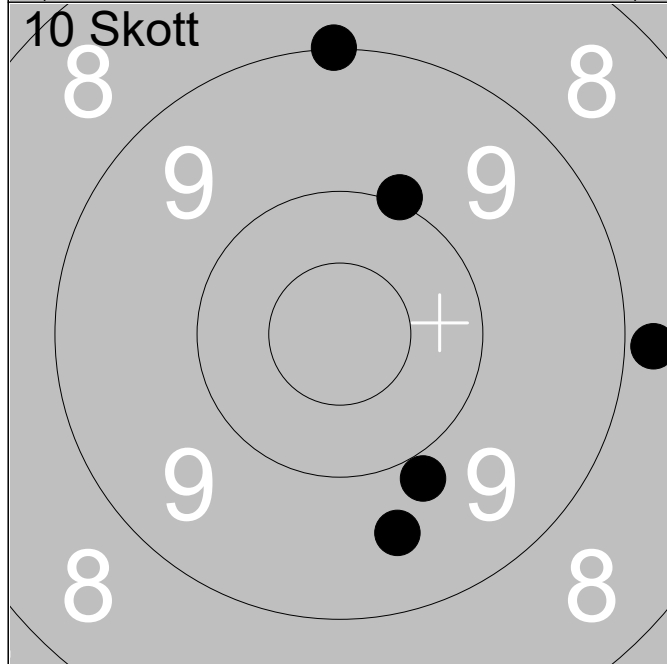

1:	8.8	→
2:	9.0	↑
3:	10.0	↗
4:	9.9	↘
5:	9.6	↘
Serie		45.0
Total		276.0

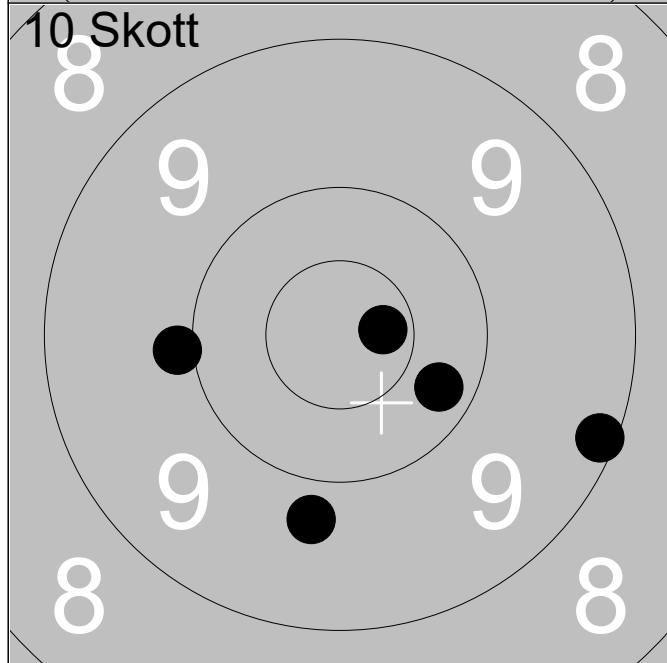

6:	9.1	→
7:	10.2	↘
8:	9.9	←
9:	9.8	↘
10:	10.7x	→
Serie		47.0
Total		323.0

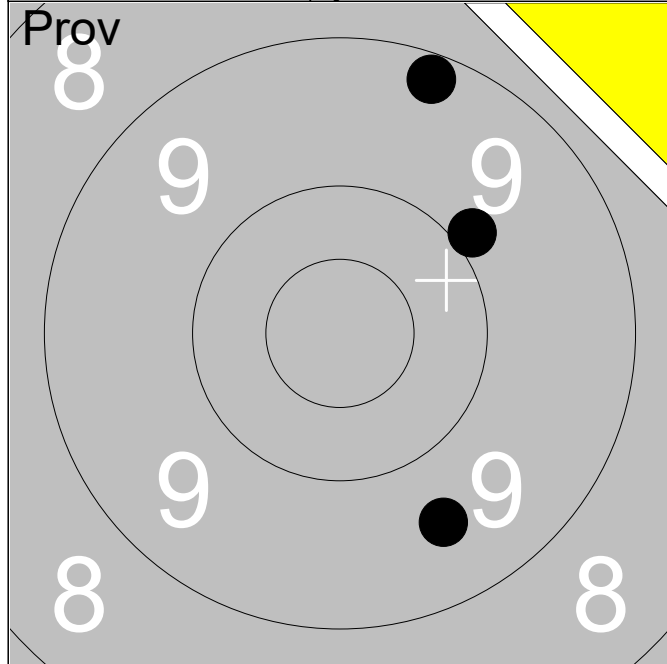

	1:	9.2		↑
	2:	9.6		↓
	3:	9.9		↗

Serie	27.0
Total	230.0

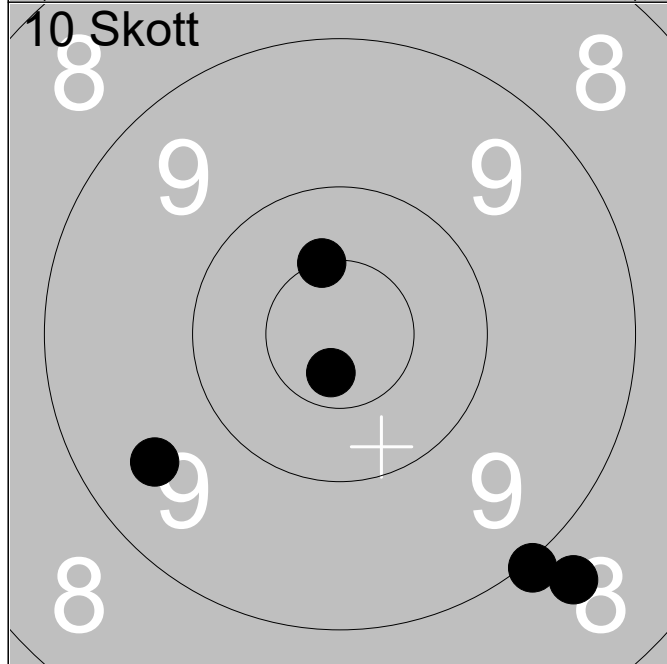

	1:	10.7x		↓
	2:	10.5x		↑
	3:	9.5		↙
	4:	9.0		↓
	5:	8.7		↓

Serie	46.0
Total	276.0

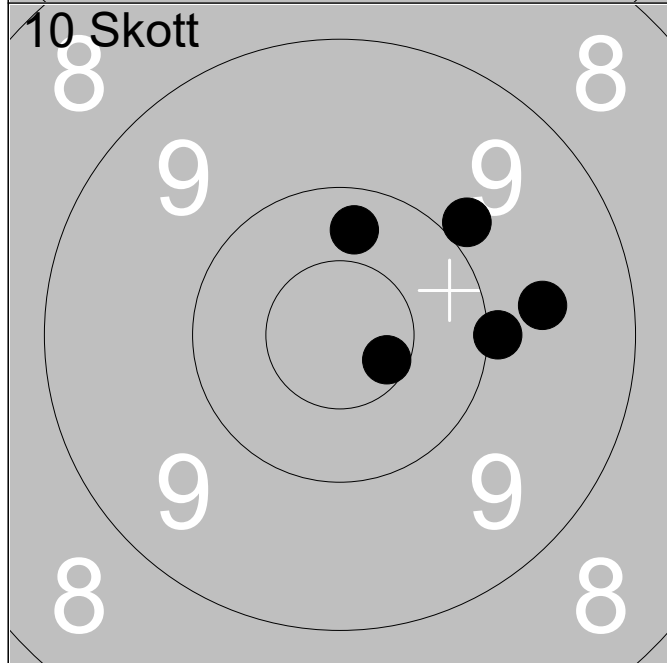

	6:	10.6x		↘
	7:	10.0		→
	8:	9.9		↗
	9:	9.6		→
	10:	10.3		↑

Serie	48.0
Total	324.0

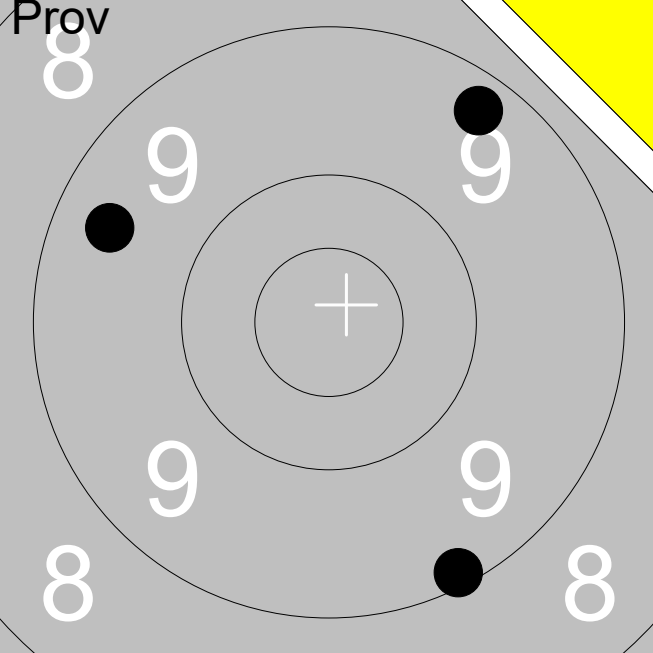
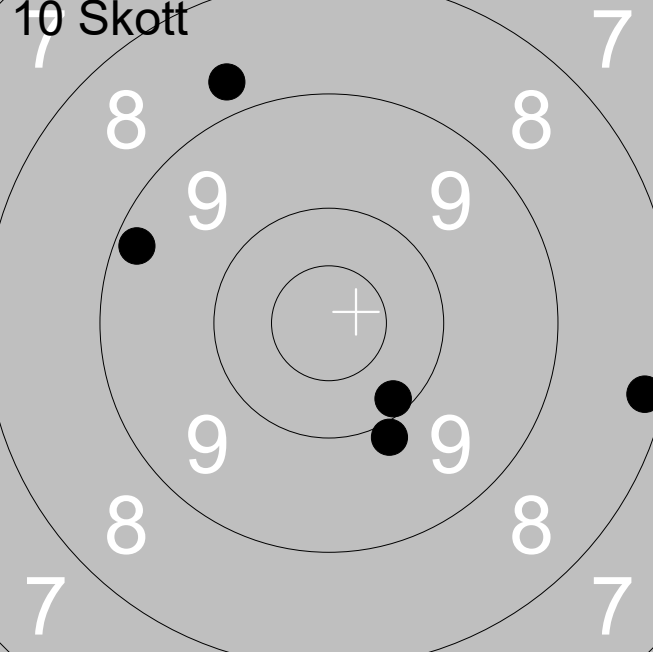
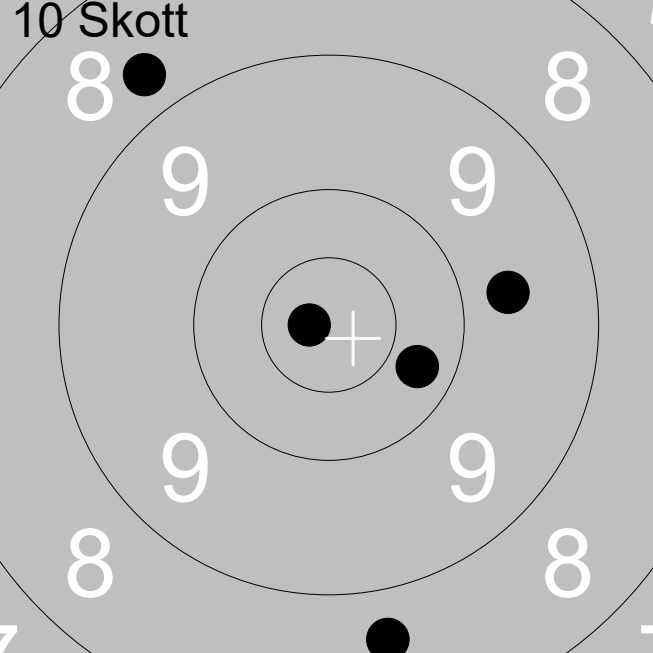
13.07.2023	Björkskottet 2023	Ramselefors SKF	
Prov 		1: 9.4	↗
		2: 9.3	↗
		3: 9.1	↘
		Serie	27.0
		Total	227.0
10 Skott 		1: 9.2	↗
		2: 9.9	↘
		3: 10.1	↘
		4: 8.7	↗
		5: 8.2	↘
		Serie	44.0
		Total	271.0
10 Skott 		6: 8.7	↗
		7: 9.7	→
		8: 10.8x	←
		9: 10.3	↘
		10: 8.7	↘
		Serie	45.0
		Total	316.0

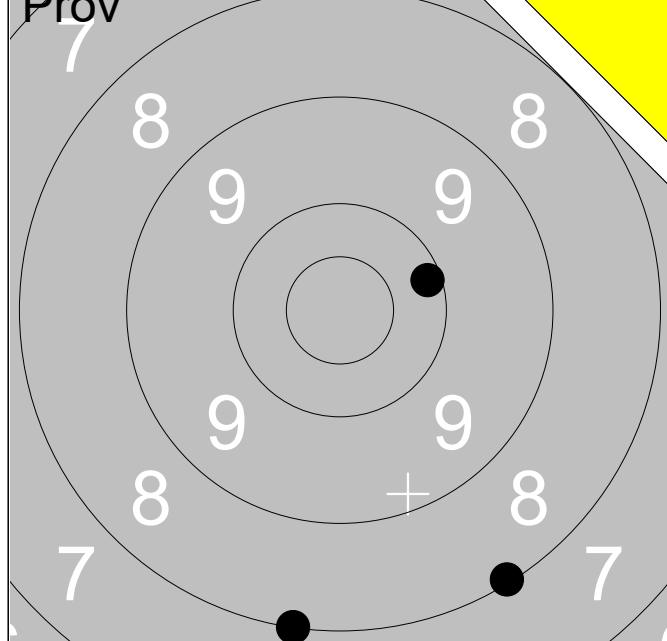

	1:	10.1	→
	2:	8.0	↓
	3:	8.1	↓
Serie			26.0
Total			226.0

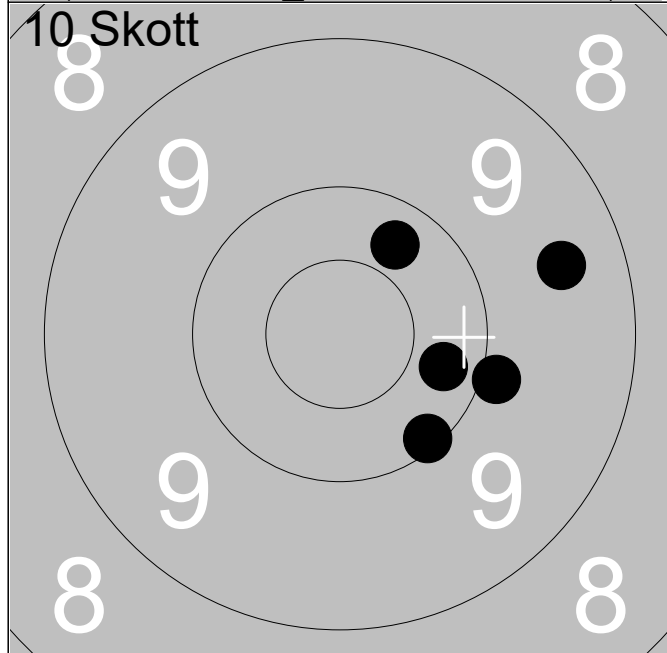

	1:	10.1	↓
	2:	9.9	→
	3:	10.3	↗
	4:	10.3	→
	5:	9.5	→
Serie			48.0
Total			274.0

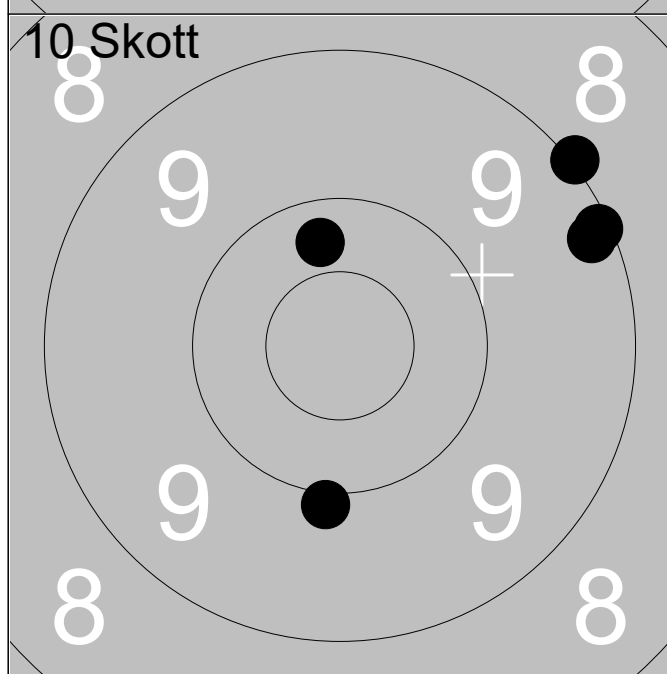

	6:	9.2	↗
	7:	9.0	↗
	8:	10.3	↑
	9:	10.0	↓
	10:	9.1	↗
Serie			47.0
Total			321.0

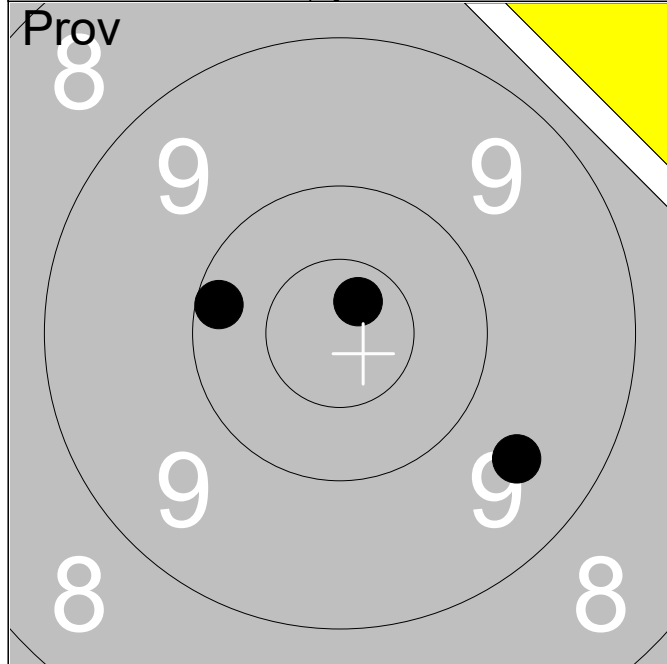

1:	9.6	↘
2:	10.7x	↗
3:	10.2	↖
Serie		29.0
Total		225.0

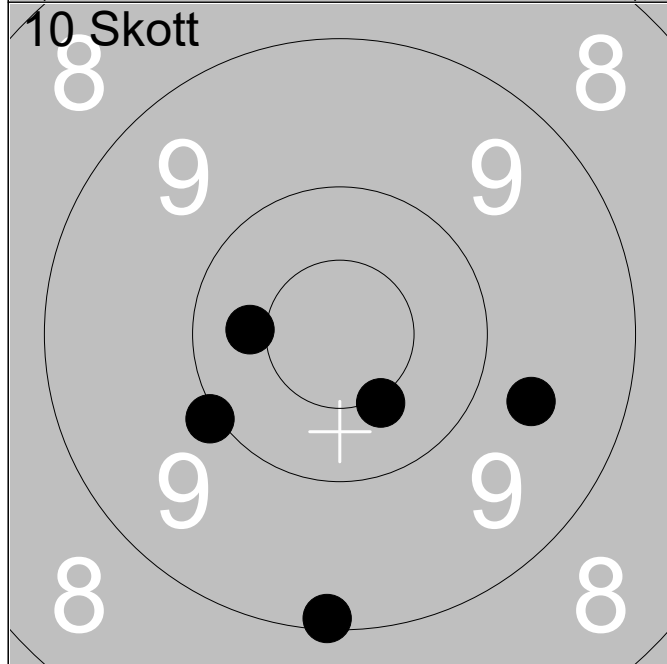

1:	9.1	↓
2:	9.7	↗
3:	10.4x	↘
4:	10.4	↖
5:	10.0	↙
Serie		48.0
Total		273.0

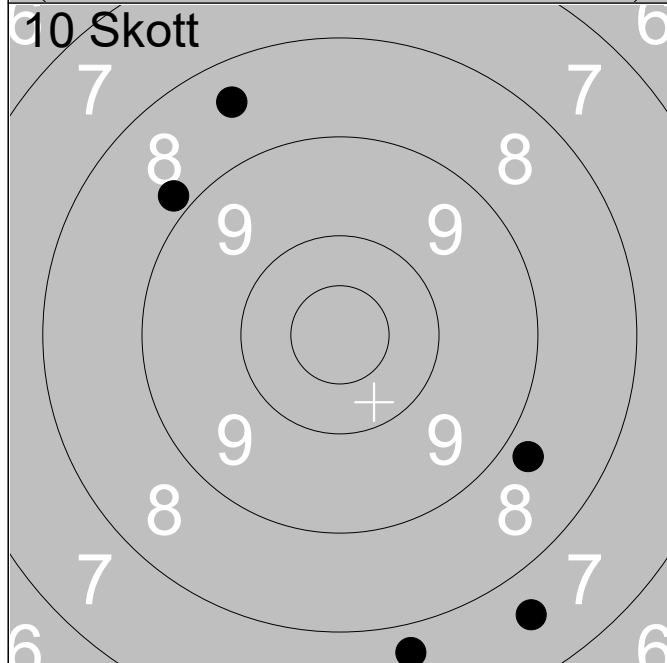

6:	8.8	↘
7:	8.8	↗
8:	7.7	↘
9:	8.4	↗
10:	7.6	↘
Serie		38.0
Total		311.0

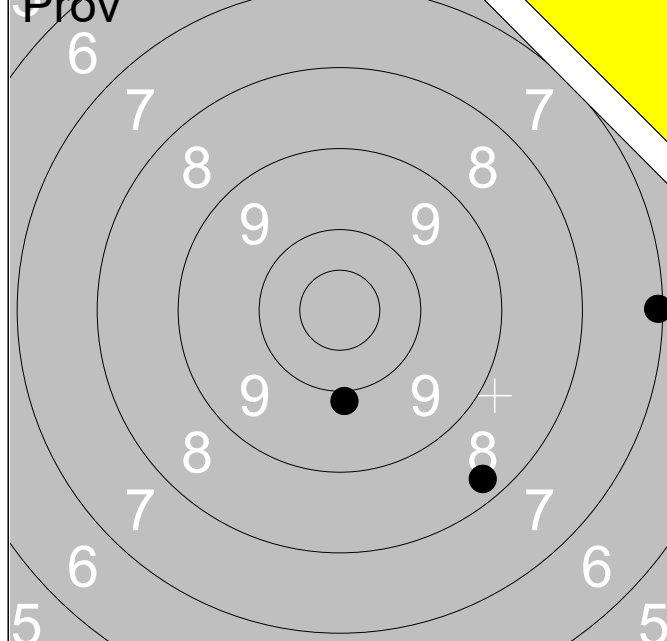

1:	7.1	→
2:	8.3	↘
3:	9.9	↓
Serie		24.0
Total		224.0

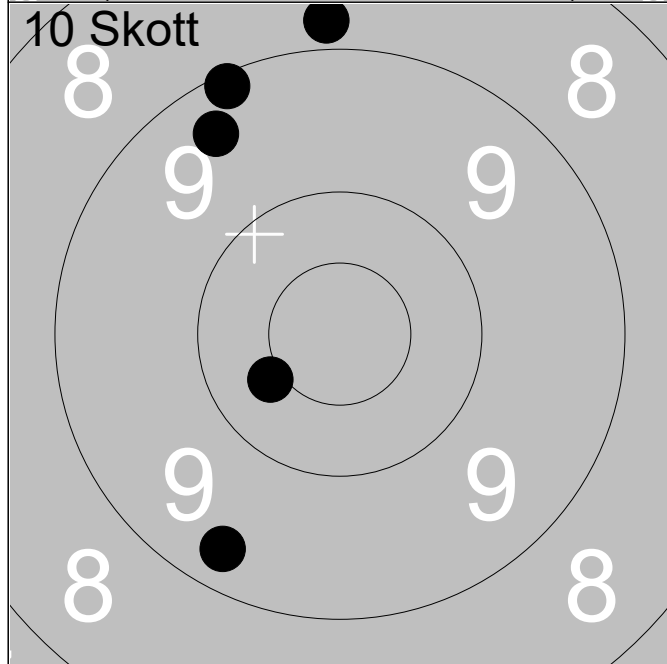

1:	10.4	↙
2:	9.4	↗
3:	8.8	↑
4:	9.1	↗
5:	9.3	↘
Serie		45.0
Total		269.0

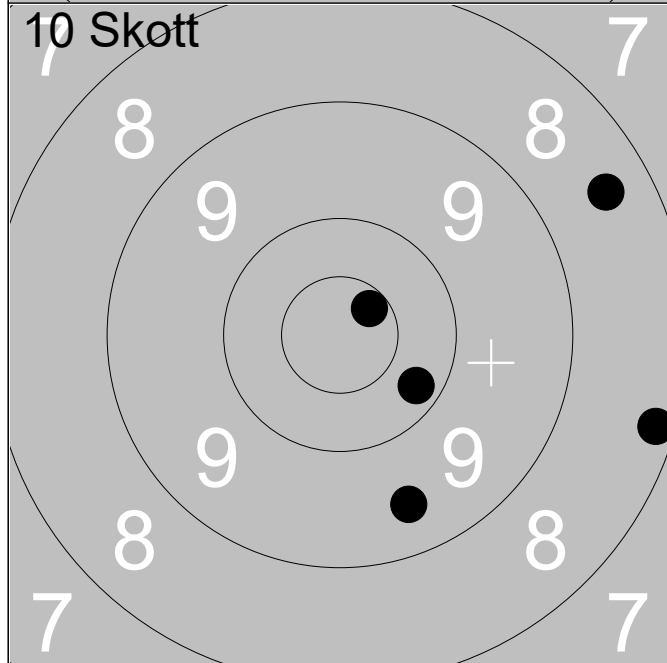

6:	10.6x	↗
7:	10.2	↘
8:	8.4	↗
9:	8.2	→
10:	9.5	↓
Serie		45.0
Total		314.0

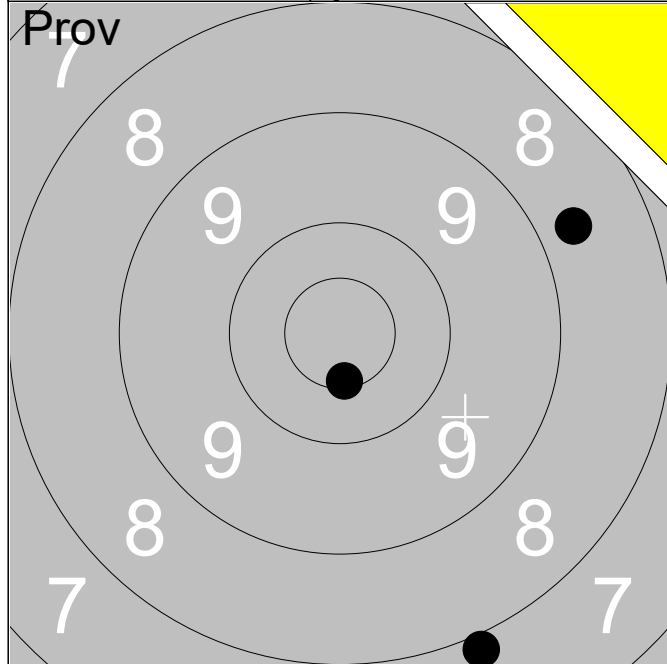

1:	8.7	→
2:	10.5x	↓
3:	7.9	↓
Serie		25.0
Total		223.0

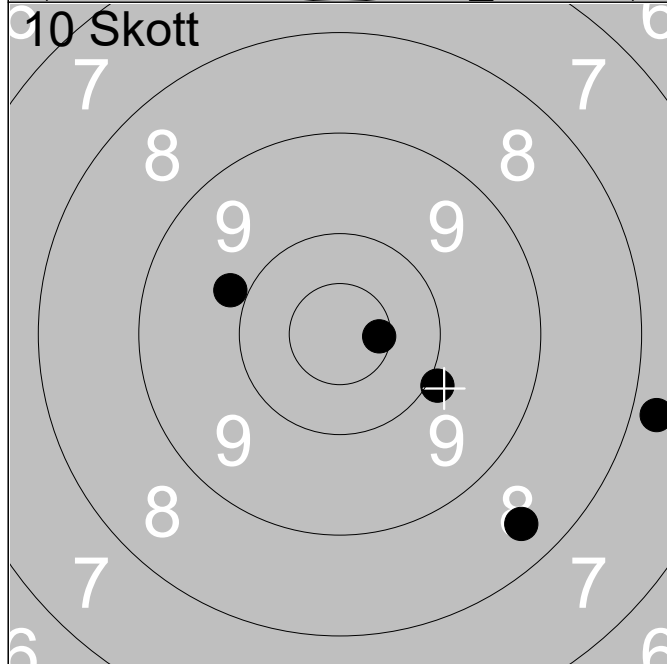

1:	10.6x	→
2:	9.9	↓
3:	9.9	↗
4:	7.8	→
5:	8.4	↓
Serie		43.0
Total		266.0

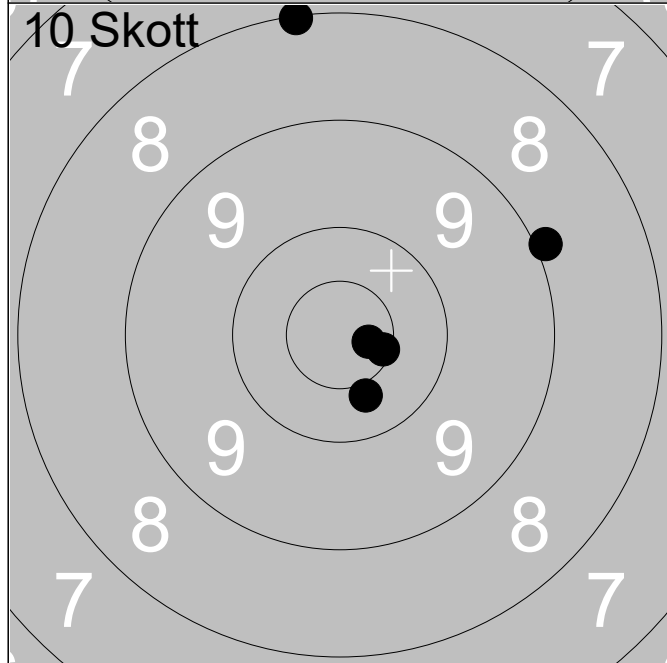

6:	10.6x	→
7:	10.7x	→
8:	10.4	↓
9:	8.9	↗
10:	8.1	↑
Serie		46.0
Total		312.0

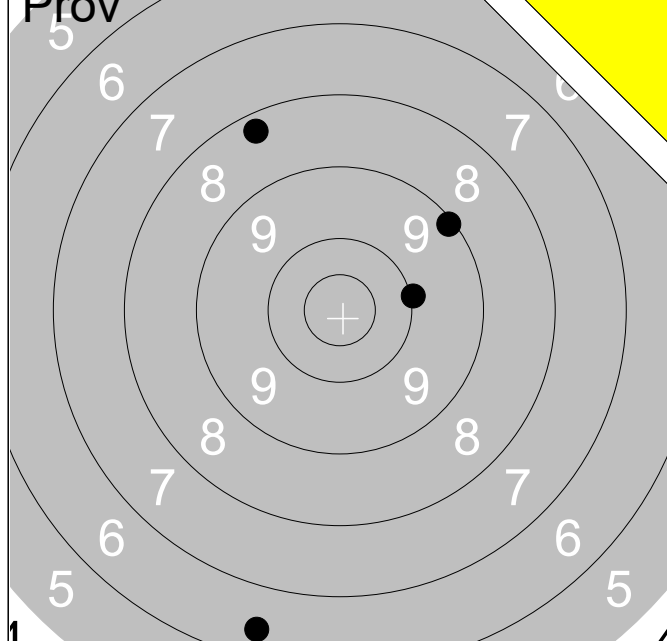

	1:	10.0	→
	2:	8.3	↑
	3:	6.4	↓
	4:	9.1	↗
Serie			33.0
Total			223.0

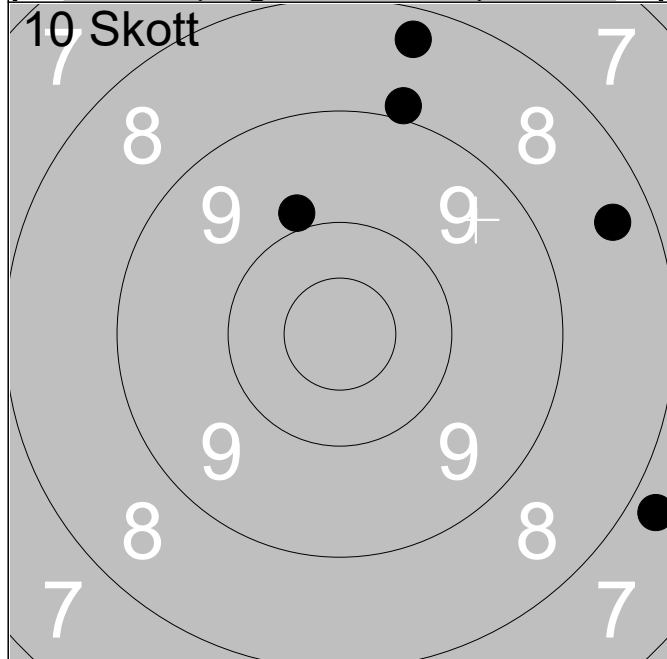

	1:	7.8	↘
	2:	8.3	↑
	3:	9.9	↑
	4:	8.9	↑
	5:	8.4	↗
Serie			40.0
Total			263.0

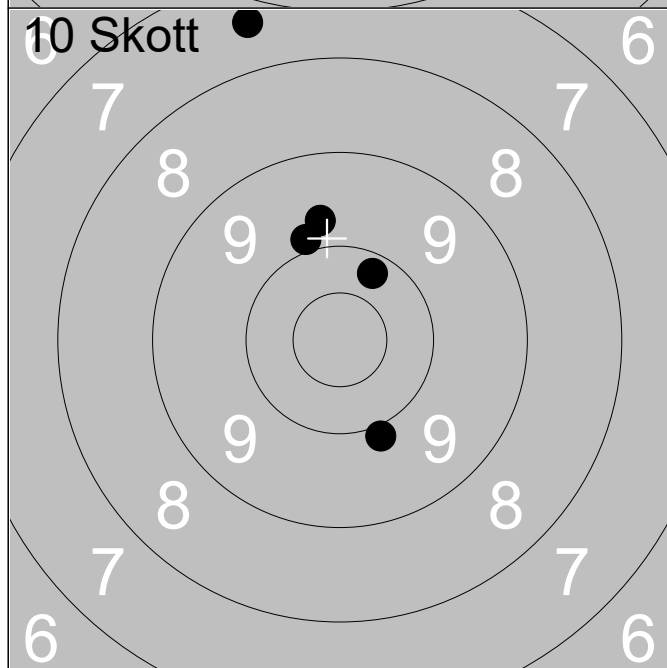

	6:	9.7	↑
	7:	10.2	↗
	8:	7.5	↑
	9:	9.9	↑
	10:	9.9	↓
Serie			44.0
Total			307.0

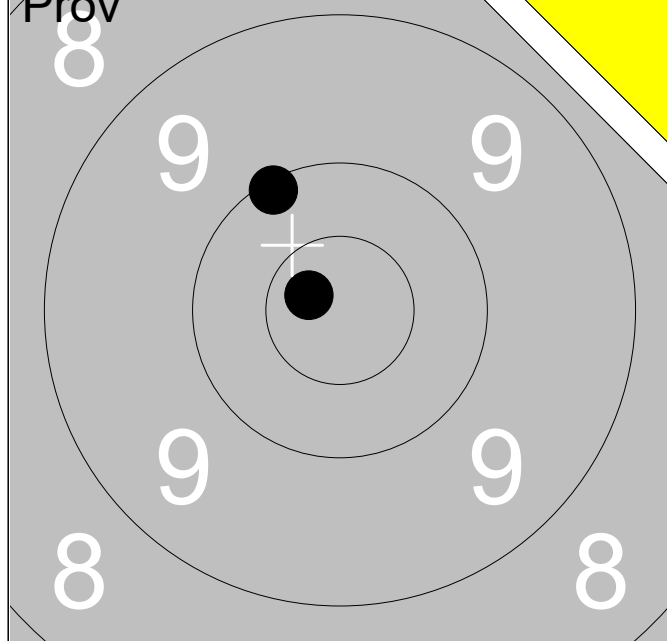

	1:	10.1	↗
	2:	10.7x	↖
Serie			20.0
Total			212.0

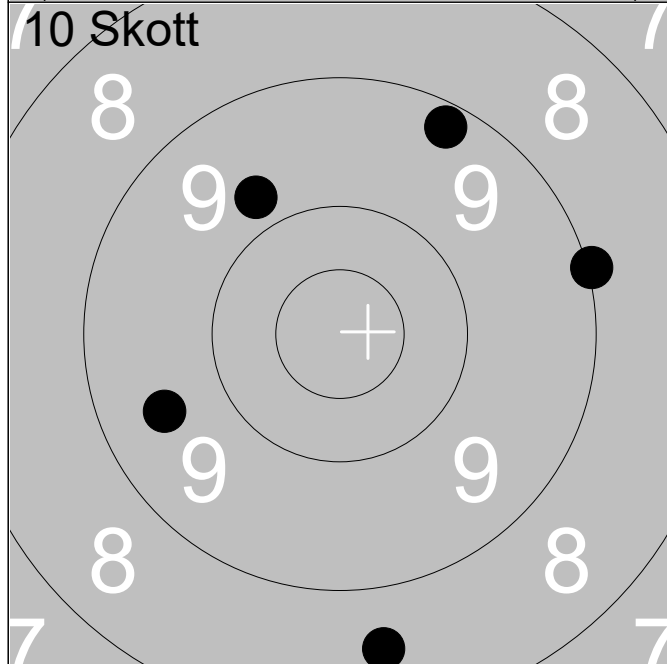

	1:	8.5	↓
	2:	9.5	↖
	3:	9.2	↗
	4:	9.8	↖
	5:	9.0	→
Serie			44.0
Total			256.0

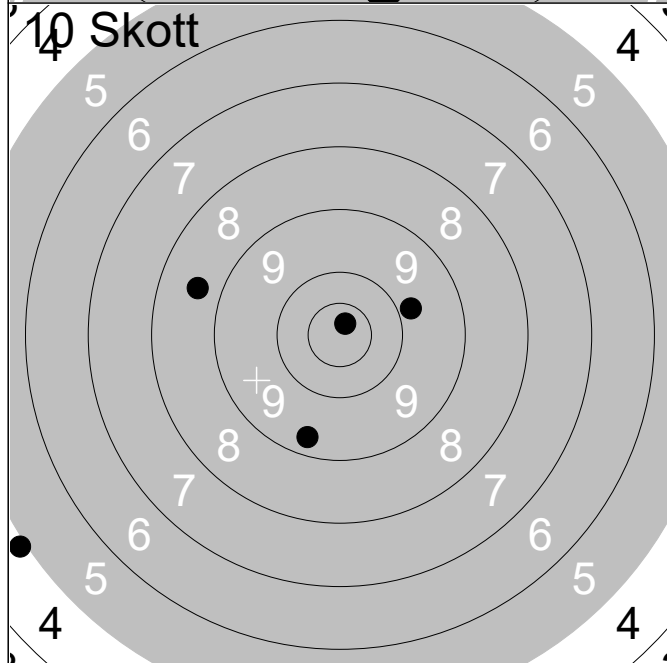

	6:	9.8	→
	7:	4.9	↖
	8:	10.8x	↗
	9:	9.3	↓
	10:	8.6	↖
Serie			40.0
Total			296.0

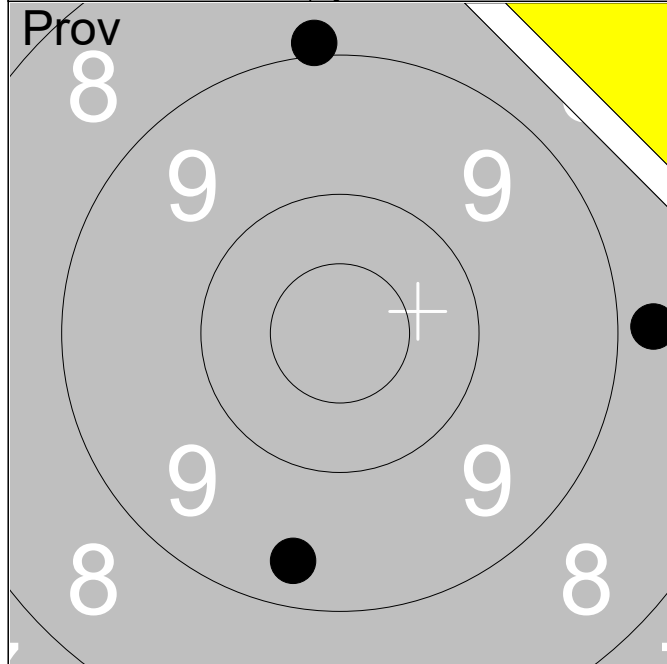

	1:	8.9	↑
	2:	9.4	↓
	3:	8.8	→
Serie			25.0
Total			207.0

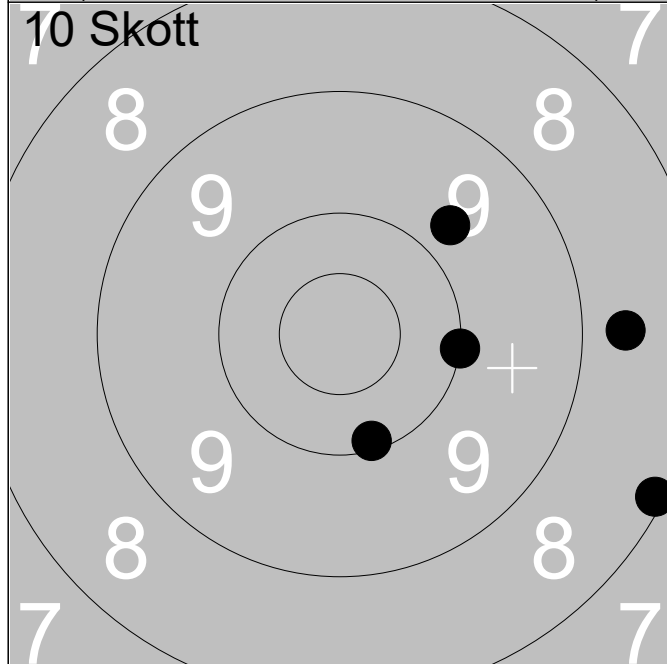

	1:	8.1	↘
	2:	9.7	↗
	3:	10.1	↓
	4:	8.7	→
	5:	10.0	→
Serie			45.0
Total			252.0

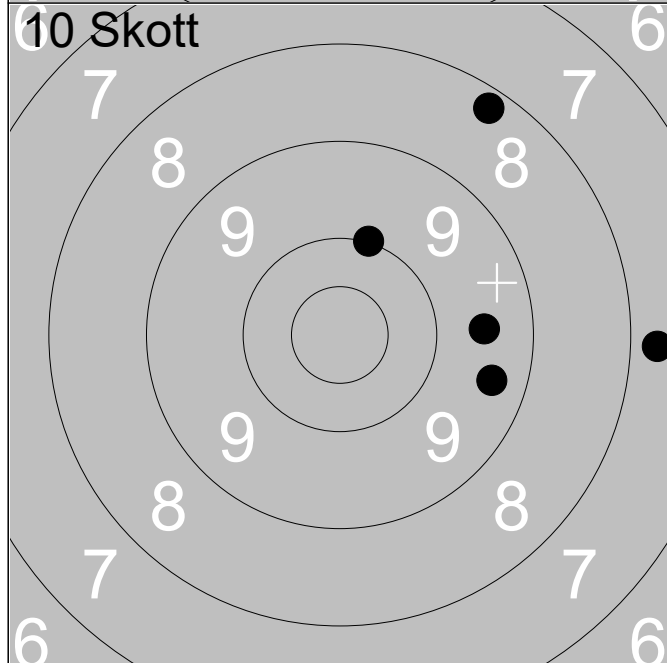

	6:	8.2	↗
	7:	9.5	→
	8:	10.0	↑
	9:	7.8	→
	10:	9.4	→
Serie			43.0
Total			295.0

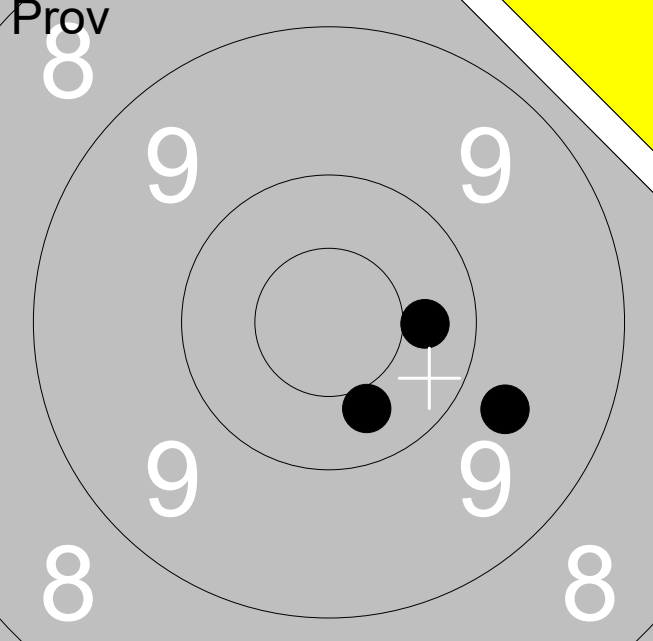
<p style="font-size: 1.5em; font-weight: bold; margin:0;">Prov</p> 	<table style="width:100%; border-collapse: collapse;"> <tr> <td style="width:10%; text-align: right;">1:</td> <td style="width:15%;">10.4</td> <td style="width:10%; text-align: right;">→</td> </tr> <tr> <td style="text-align: right;">2:</td> <td>10.4</td> <td style="text-align: right;">↓</td> </tr> <tr> <td style="text-align: right;">3:</td> <td>9.7</td> <td style="text-align: right;">↘</td> </tr> </table> <hr/> <table style="width:100%; border-collapse: collapse;"> <tr> <td style="width:80%;">Serie</td> <td style="text-align: right;">29.0</td> </tr> <tr> <td>Total</td> <td style="text-align: right;">239.0</td> </tr> </table>	1:	10.4	→	2:	10.4	↓	3:	9.7	↘	Serie	29.0	Total	239.0
1:	10.4	→												
2:	10.4	↓												
3:	9.7	↘												
Serie	29.0													
Total	239.0													

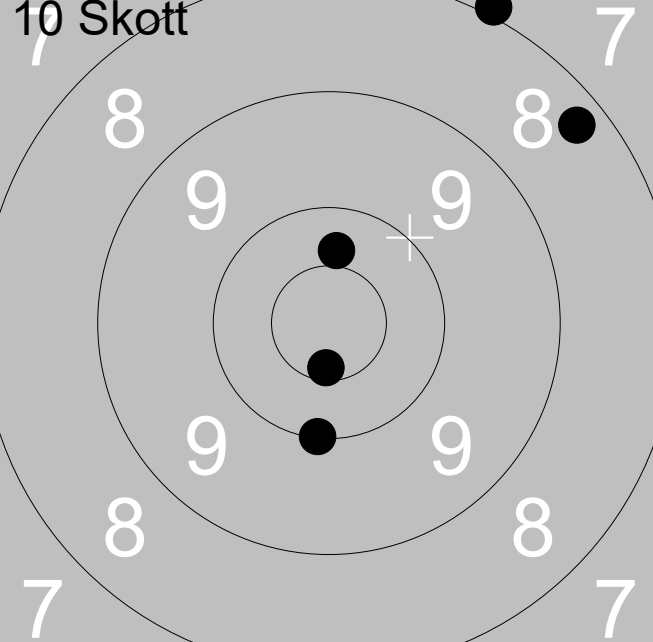
<p style="font-size: 1.5em; font-weight: bold; margin:0;">10 Skott</p> 	<table style="width:100%; border-collapse: collapse;"> <tr> <td style="width:10%; text-align: right;">1:</td> <td style="width:15%;">10.0</td> <td style="width:10%; text-align: right;">↓</td> </tr> <tr> <td style="text-align: right;">2:</td> <td>10.6x</td> <td style="text-align: right;">↓</td> </tr> <tr> <td style="text-align: right;">3:</td> <td>10.4</td> <td style="text-align: right;">↑</td> </tr> <tr> <td style="text-align: right;">4:</td> <td>8.3</td> <td style="text-align: right;">↗</td> </tr> <tr> <td style="text-align: right;">5:</td> <td>8.0</td> <td style="text-align: right;">↑</td> </tr> </table> <hr/> <table style="width:100%; border-collapse: collapse;"> <tr> <td style="width:80%;">Serie</td> <td style="text-align: right;">46.0</td> </tr> <tr> <td>Total</td> <td style="text-align: right;">285.0</td> </tr> </table>	1:	10.0	↓	2:	10.6x	↓	3:	10.4	↑	4:	8.3	↗	5:	8.0	↑	Serie	46.0	Total	285.0
1:	10.0	↓																		
2:	10.6x	↓																		
3:	10.4	↑																		
4:	8.3	↗																		
5:	8.0	↑																		
Serie	46.0																			
Total	285.0																			

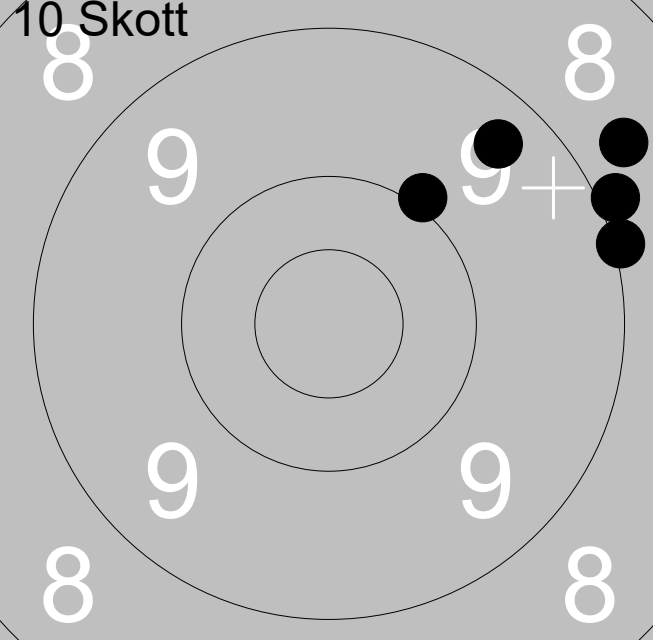
<p style="font-size: 1.5em; font-weight: bold; margin:0;">10 Skott</p> 	<table style="width:100%; border-collapse: collapse;"> <tr> <td style="width:10%; text-align: right;">6:</td> <td style="width:15%;">10.0</td> <td style="width:10%; text-align: right;">↗</td> </tr> <tr> <td style="text-align: right;">7:</td> <td>9.0</td> <td style="text-align: right;">→</td> </tr> <tr> <td style="text-align: right;">8:</td> <td>8.7</td> <td style="text-align: right;">↗</td> </tr> <tr> <td style="text-align: right;">9:</td> <td>9.4</td> <td style="text-align: right;">↗</td> </tr> <tr> <td style="text-align: right;">10:</td> <td>8.9</td> <td style="text-align: right;">→</td> </tr> </table> <hr/> <table style="width:100%; border-collapse: collapse;"> <tr> <td style="width:80%;">Serie</td> <td style="text-align: right;">44.0</td> </tr> <tr> <td>Total</td> <td style="text-align: right;">329.0</td> </tr> </table>	6:	10.0	↗	7:	9.0	→	8:	8.7	↗	9:	9.4	↗	10:	8.9	→	Serie	44.0	Total	329.0
6:	10.0	↗																		
7:	9.0	→																		
8:	8.7	↗																		
9:	9.4	↗																		
10:	8.9	→																		
Serie	44.0																			
Total	329.0																			

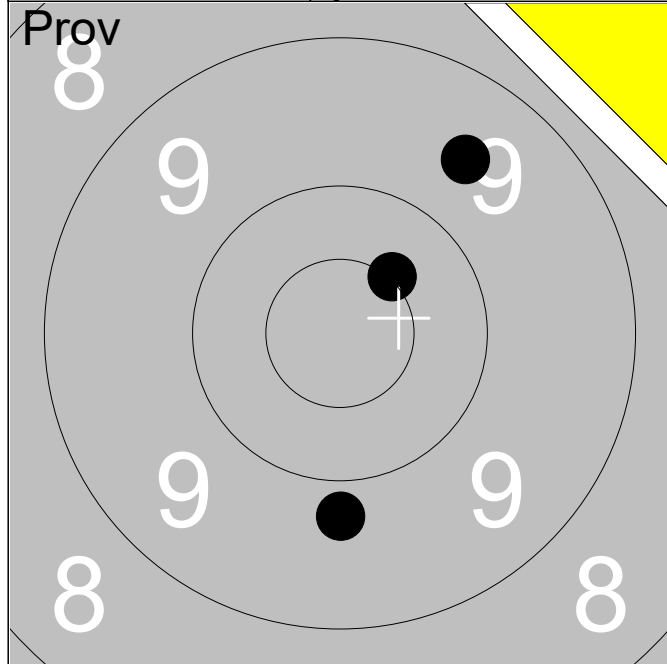

1:	10.5x	↗
2:	9.6	↗
3:	9.8	↓
Serie		28.0
Total		235.0

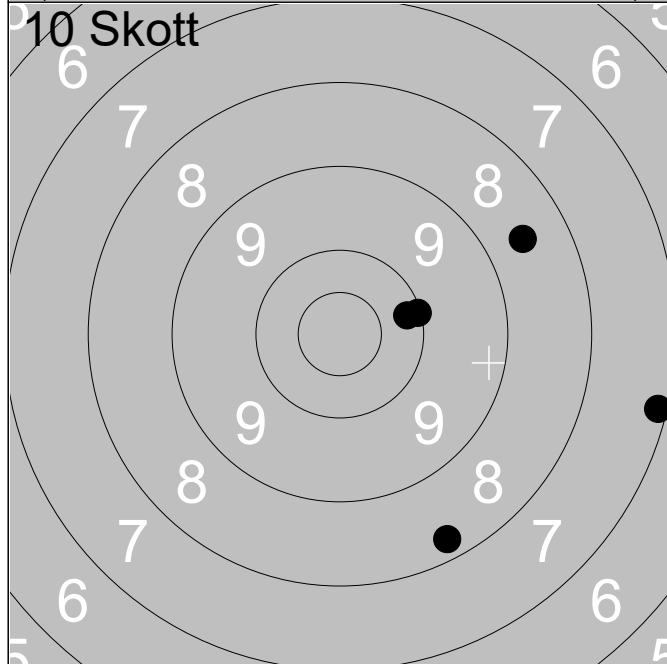

1:	10.1	→
2:	7.1	→
3:	8.3	↓
4:	8.6	↗
5:	10.2	→
Serie		43.0
Total		278.0

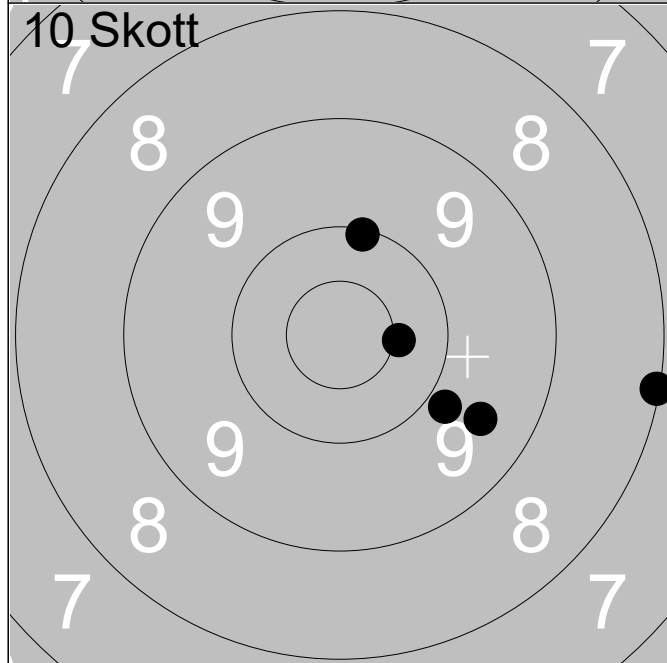

6:	10.1	↑
7:	10.4x	→
8:	9.9	↘
9:	8.1	→
10:	9.5	↘
Serie		46.0
Total		324.0

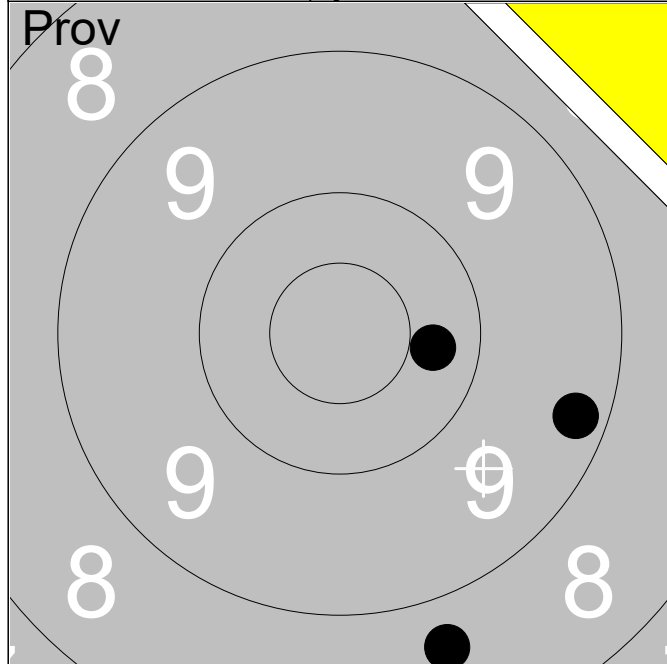

	1:	8.7	↘
	2:	9.3	→
	3:	10.3	→
Serie			27.0
Total			231.0

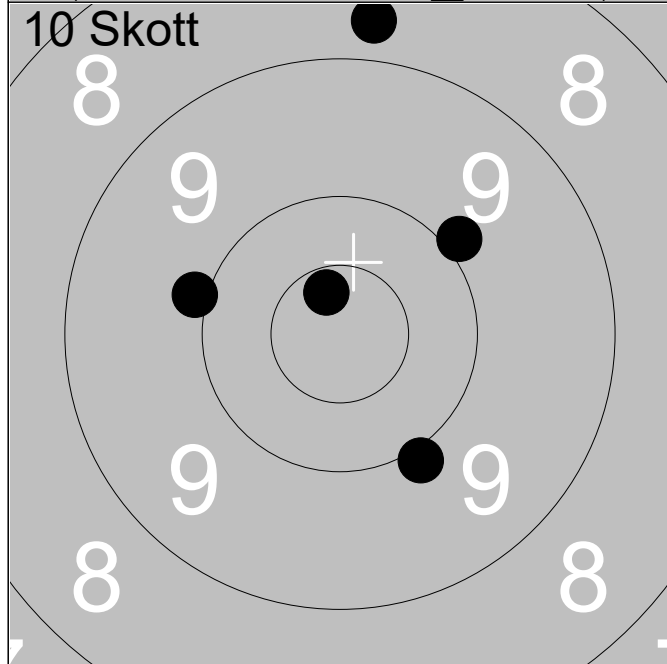

	1:	9.9	←
	2:	8.7	↑
	3:	9.9	↘
	4:	9.9	↗
	5:	10.7x	↑
Serie			45.0
Total			276.0

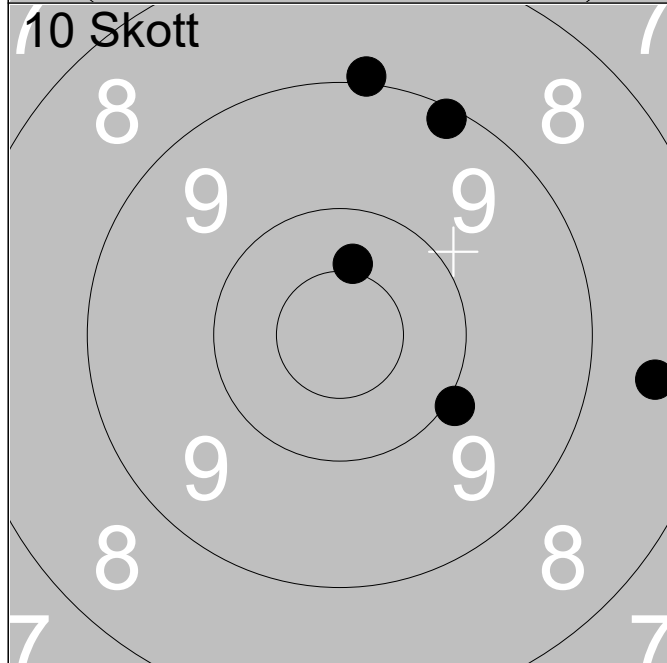

	6:	10.0	↘
	7:	10.4x	↑
	8:	9.1	↗
	9:	9.0	↑
	10:	8.5	→
Serie			46.0
Total			322.0

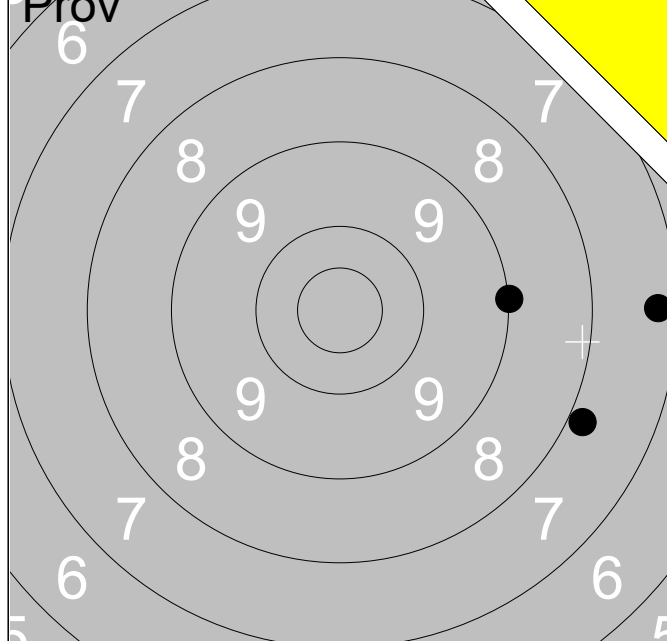

1:	7.2	→
2:	7.9	→
3:	9.0	→
Serie		23.0
Total		231.0

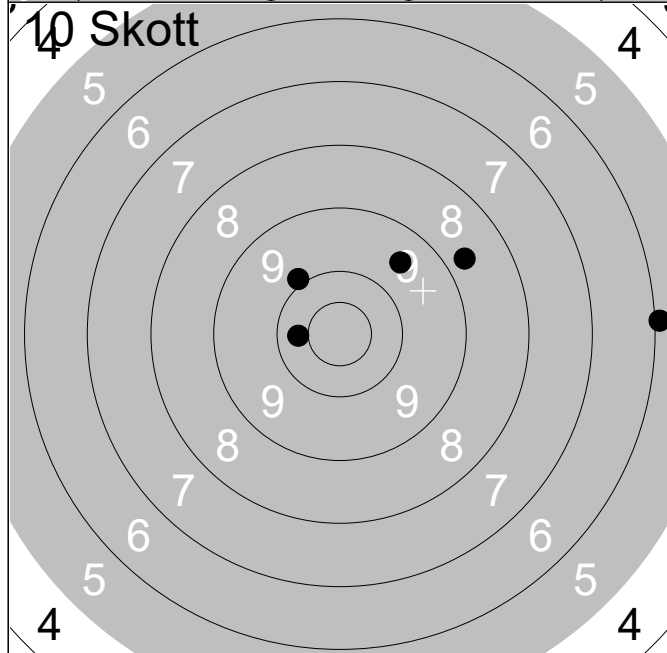

1:	10.3	←
2:	9.9	↖
3:	9.5	↗
4:	6.0	→
5:	8.7	↗
Serie		42.0
Total		273.0

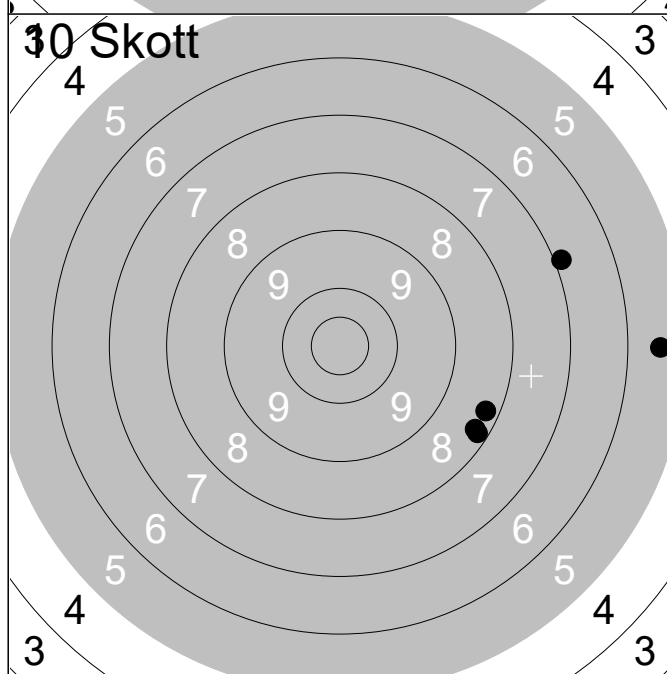

6:	6.9	↗
7:	5.5	→
8:	8.3	↘
9:	8.2	↘
10:	8.3	↘
Serie		35.0
Total		308.0

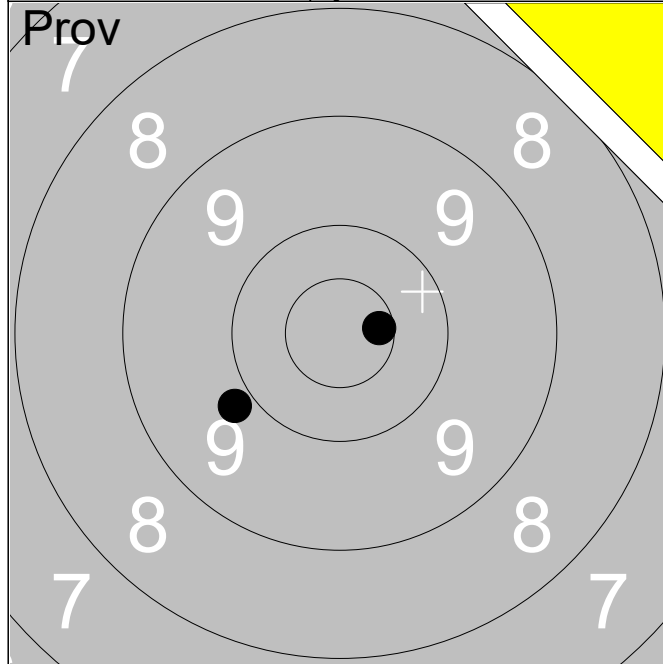

	1:	10.6x	→
	2:	9.8	↙
	3:	7.6	↗
Serie			26.0
Total			230.0

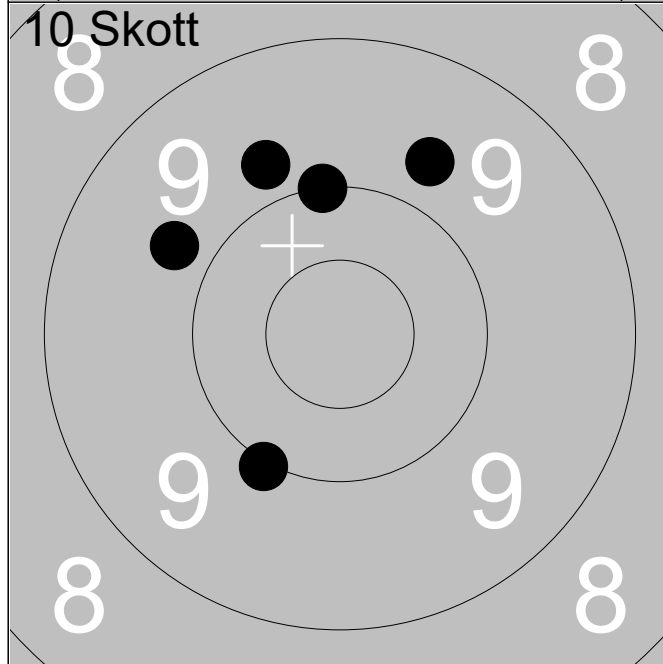

	1:	9.7	↗
	2:	9.8	↖
	3:	10.0	↘
	4:	9.8	↙
	5:	10.0	↕
Serie			47.0
Total			277.0

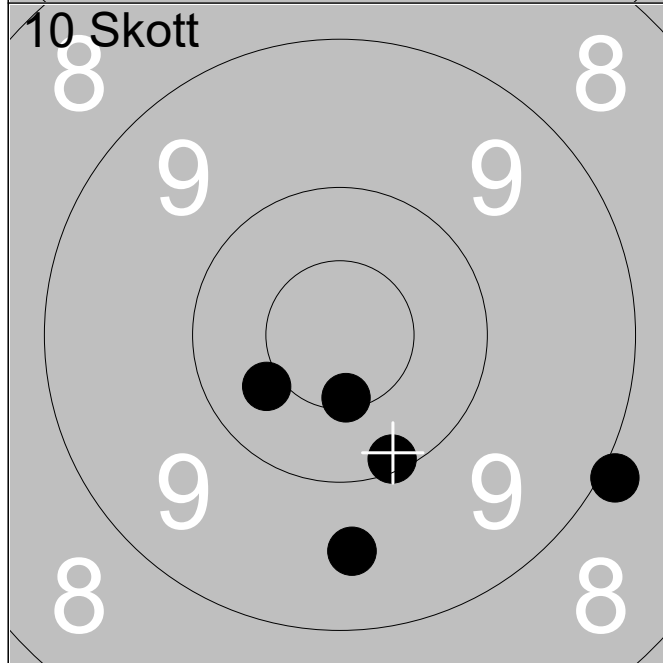

	6:	10.4	↙
	7:	8.9	↘
	8:	9.6	↓
	9:	10.1	↘
	10:	10.6x	↓
Serie			47.0
Total			324.0

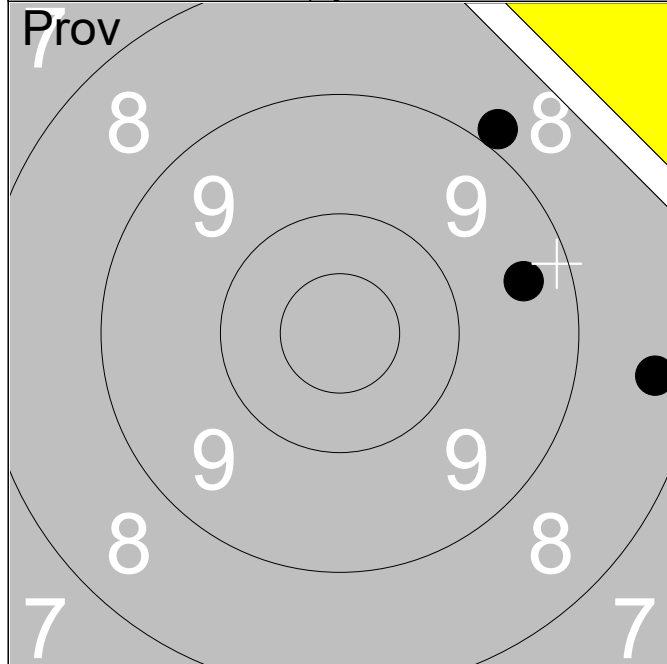

1:	9.4	→
2:	8.4	→
3:	8.9	↗

Serie	25.0
Total	229.0

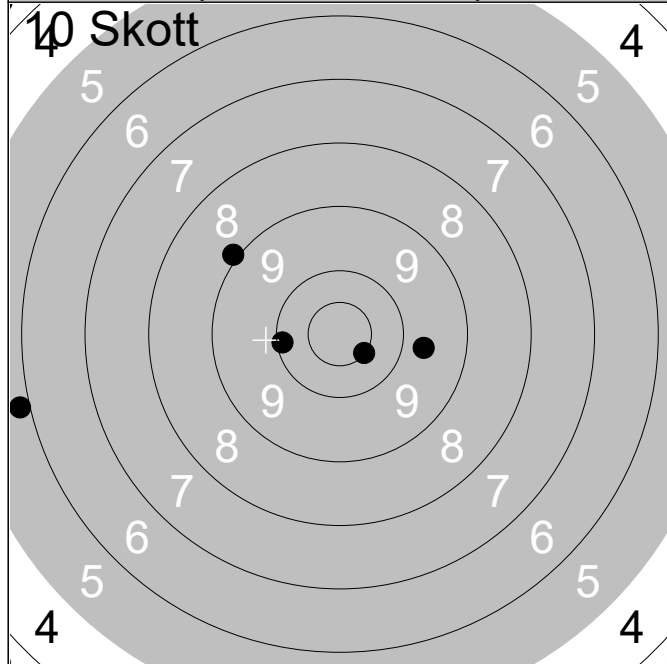

1:	8.9	↗
2:	10.5x	↓
3:	10.1	←
4:	5.9	←
5:	9.7	→

Serie	42.0
Total	271.0

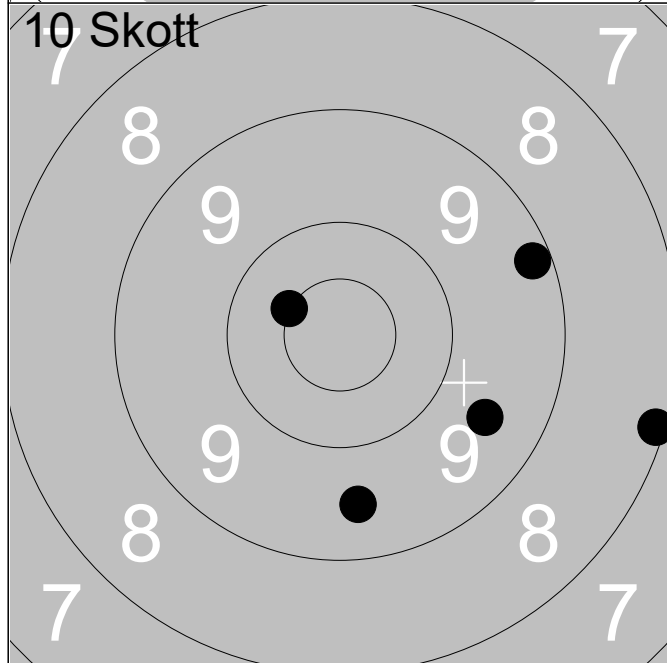

6:	9.2	→
7:	9.5	↓
8:	8.1	→
9:	10.5x	↗
10:	9.5	↓

Serie	45.0
Total	316.0

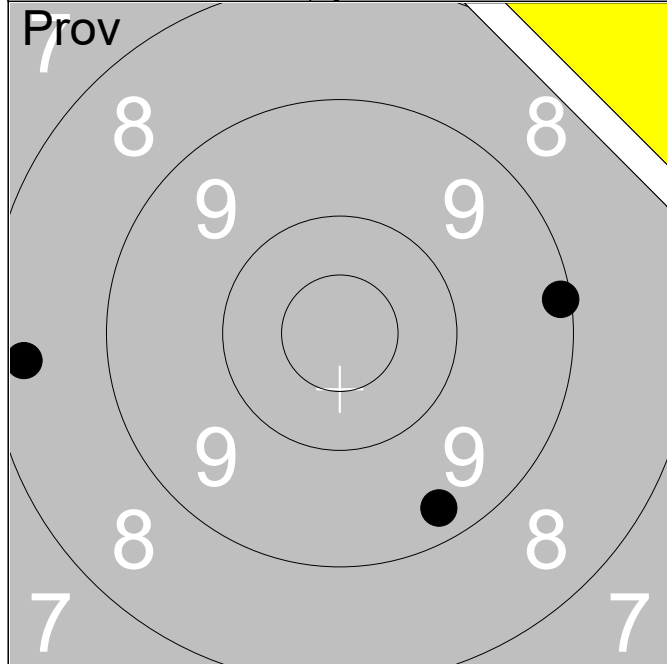

	1:	9.1	→
	2:	9.3	↓
	3:	8.3	←
Serie			26.0
Total			228.0

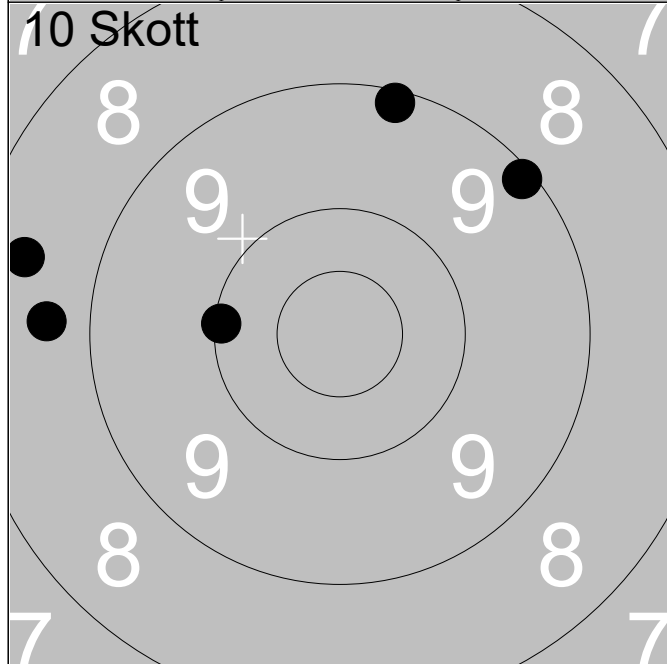

	1:	8.4	←
	2:	8.7	←
	3:	10.1	←
	4:	9.1	↗
	5:	9.1	↑
Serie			44.0
Total			272.0

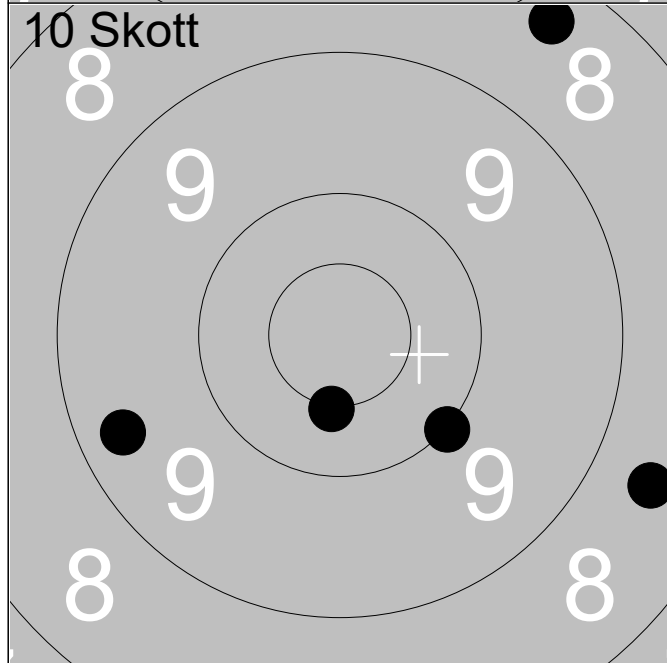

	6:	8.4	↗
	7:	10.5x	↓
	8:	9.3	←
	9:	8.6	→
	10:	10.0	↓
Serie			45.0
Total			317.0

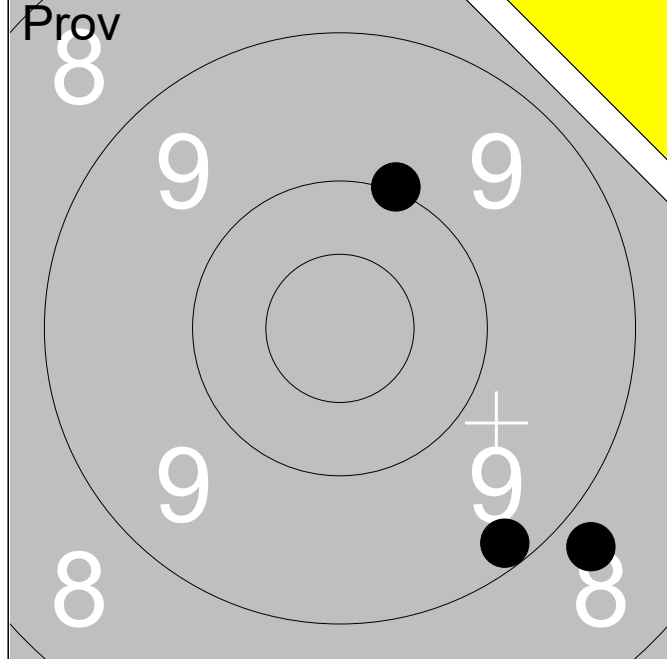

1:	8.8	↘
2:	9.2	↘
3:	10.0	↗
Serie		27.0
Total		227.0

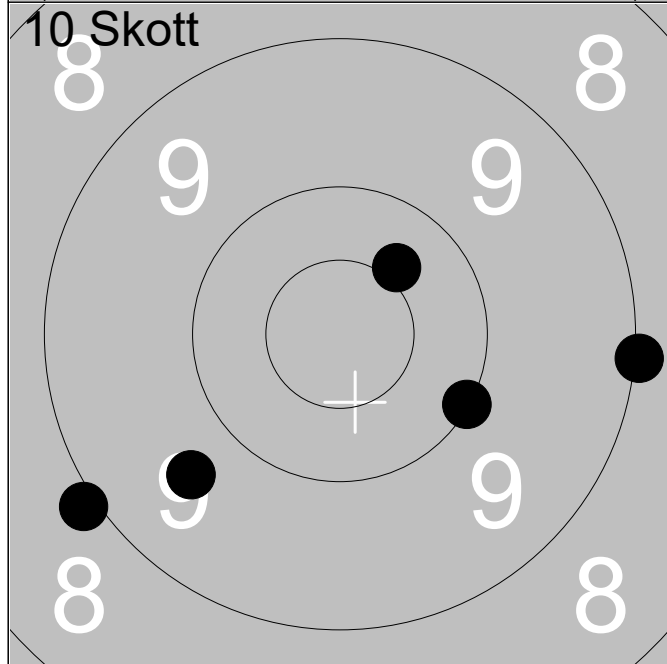

1:	9.6	↙
2:	9.0	→
3:	8.9	↙
4:	10.0	↘
5:	10.4	↗
Serie		46.0
Total		273.0

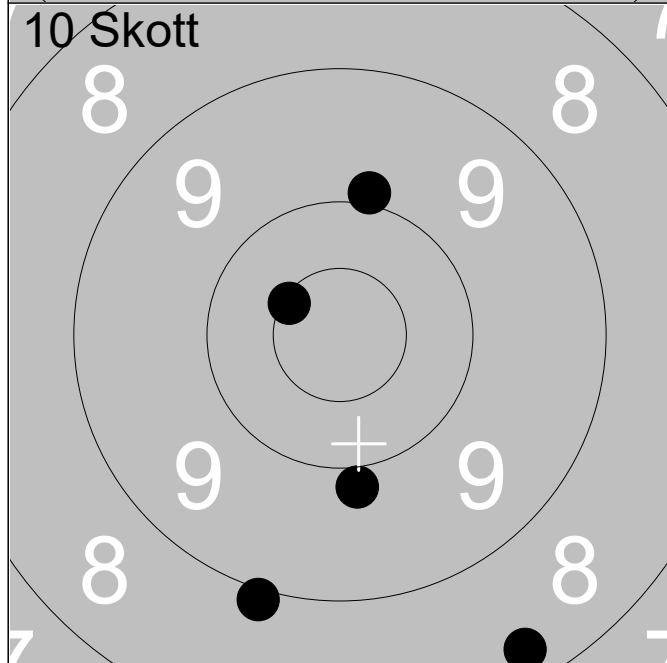

6:	8.3	↘
7:	10.5x	↗
8:	9.9	↘
9:	8.9	↘
10:	9.9	↗
Serie		44.0
Total		317.0

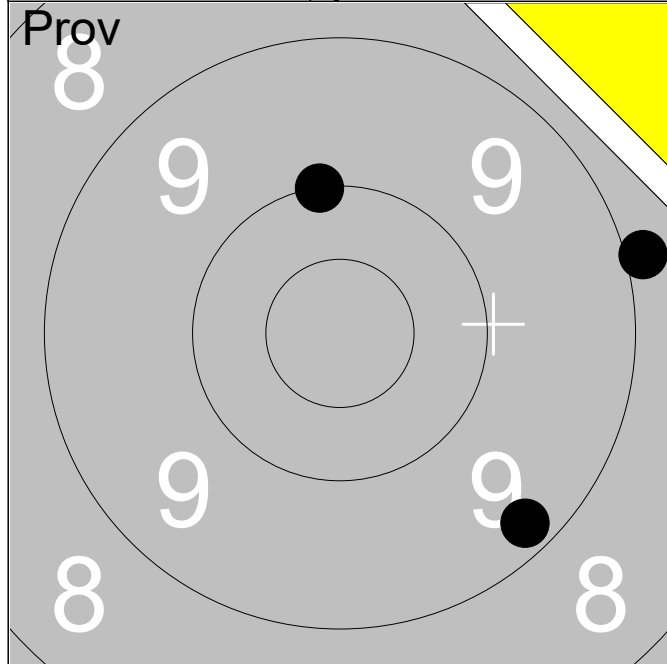

1:	8.9	→
2:	9.2	↘
3:	10.0	↑

Serie	27.0
Total	227.0

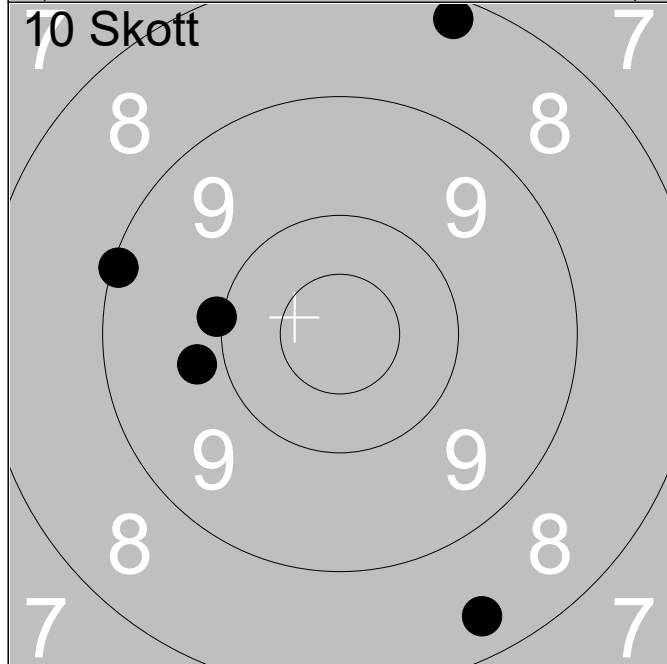

1:	8.2	↑
2:	9.1	←
3:	8.4	↘
4:	10.0	←
5:	9.8	←

Serie	44.0
Total	271.0

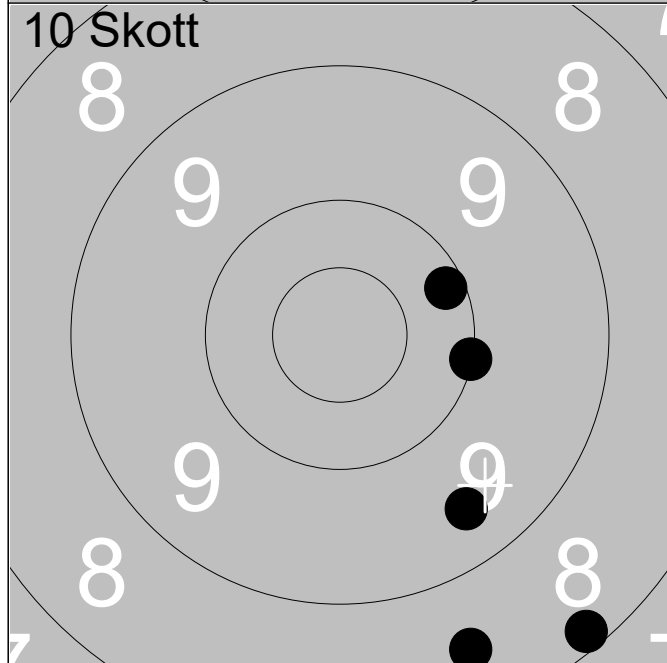

6:	8.2	↘
7:	10.0	→
8:	10.2	→
9:	8.5	↘
10:	9.4	↘

Serie	45.0
Total	316.0

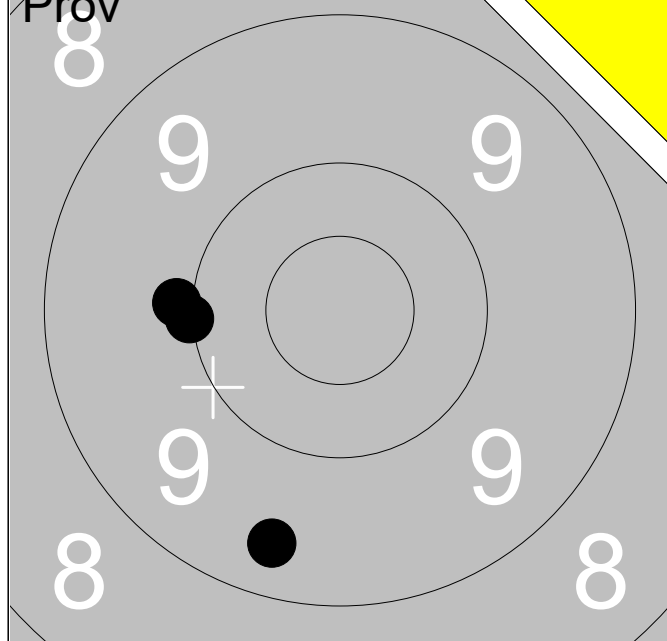

1:	9.9	←
2:	10.0	←
3:	9.4	↓
Serie		28.0
Total		226.0

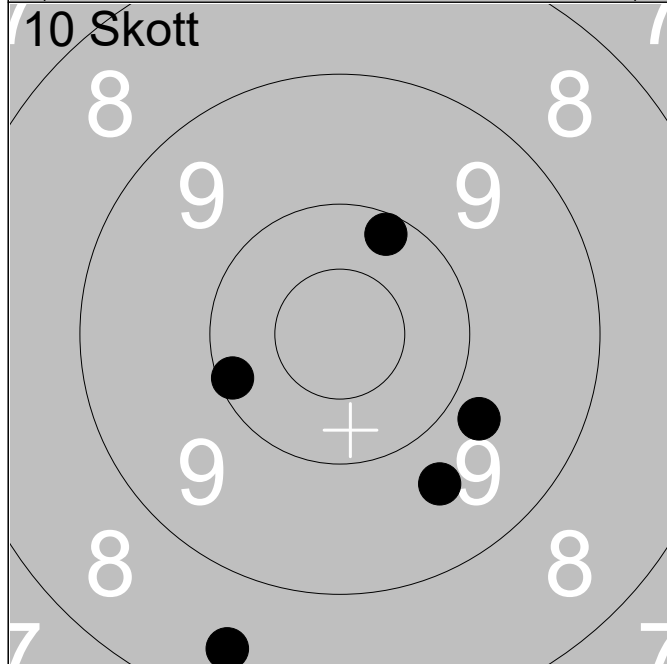

1:	10.2	↑
2:	9.6	↓
3:	9.8	↓
4:	10.1	←
5:	8.5	↓
Serie		46.0
Total		272.0

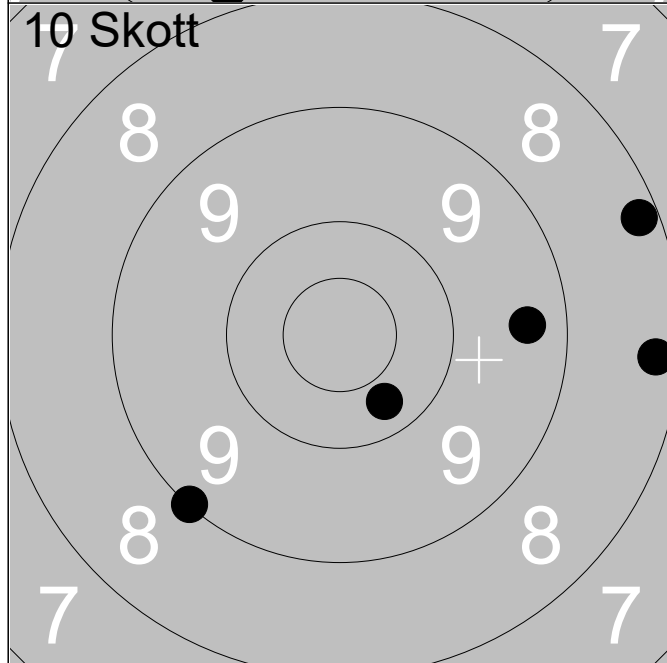

6:	9.0	↙
7:	8.2	→
8:	9.4	→
9:	8.2	→
10:	10.3	↓
Serie		44.0
Total		316.0

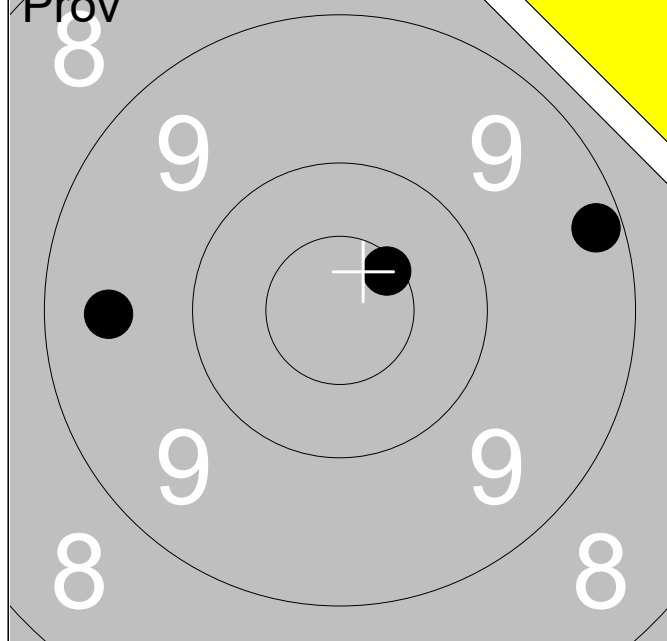

1:	9.2	→
2:	9.5	←
3:	10.6x	↗
Serie		28.0
Total		220.0

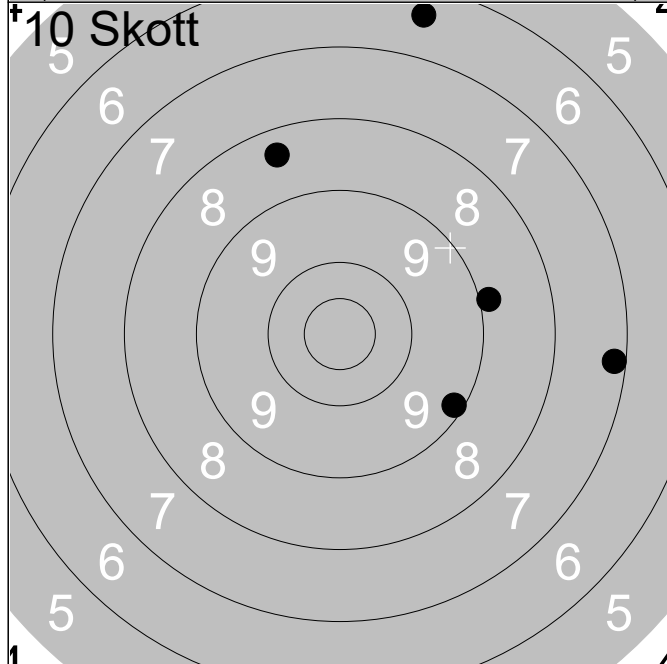

1:	6.4	↑
2:	7.2	→
3:	8.4	↑
4:	8.9	→
5:	9.2	↘
Serie		38.0
Total		258.0

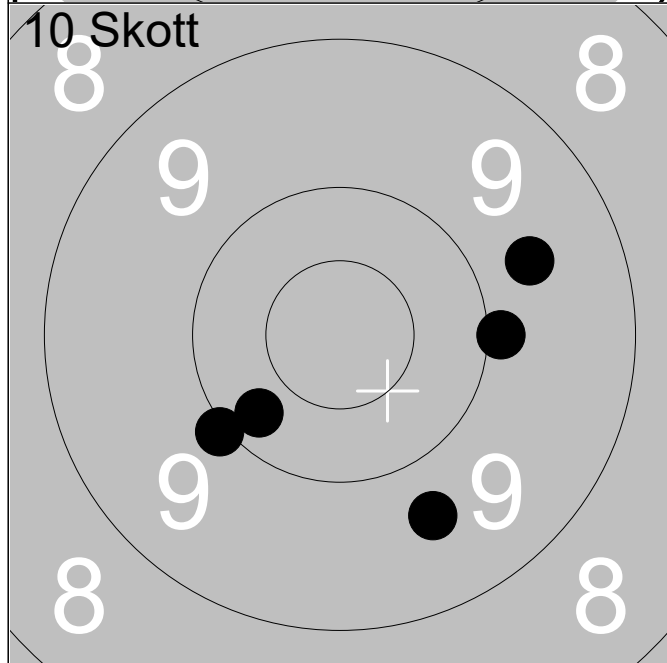

6:	9.7	→
7:	10.2	↙
8:	10.0	↙
9:	9.9	→
10:	9.7	↘
Serie		47.0
Total		305.0

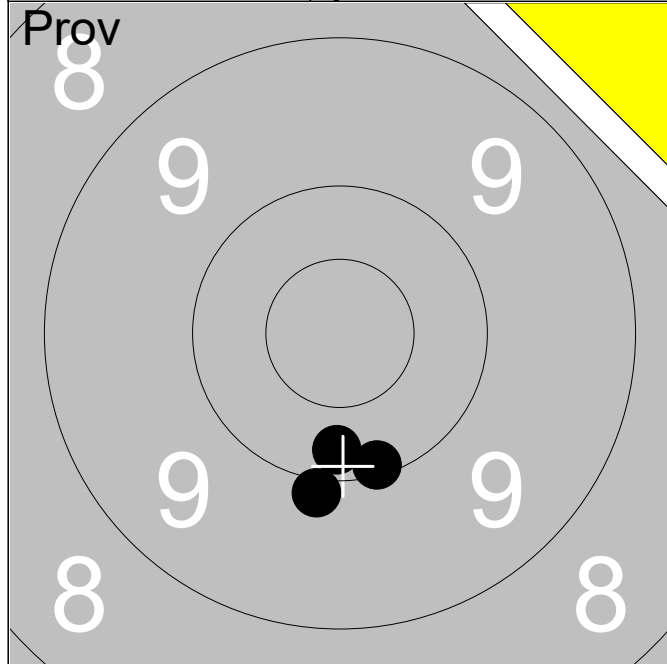

	1:	10.2	↓
	2:	9.9	↓
	3:	10.1	↓
Serie			29.0
Total			220.0

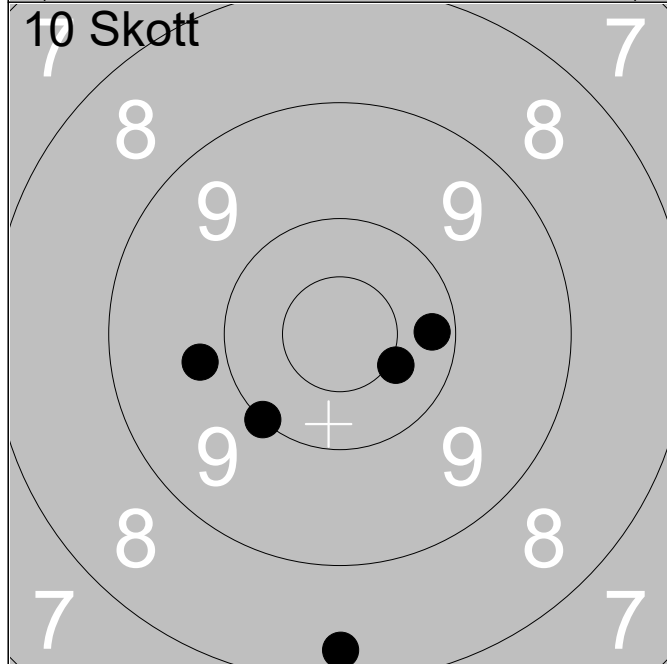

	1:	8.3	↓
	2:	10.0	↙
	3:	10.2	→
	4:	10.4x	↘
	5:	9.8	←
Serie			47.0
Total			267.0

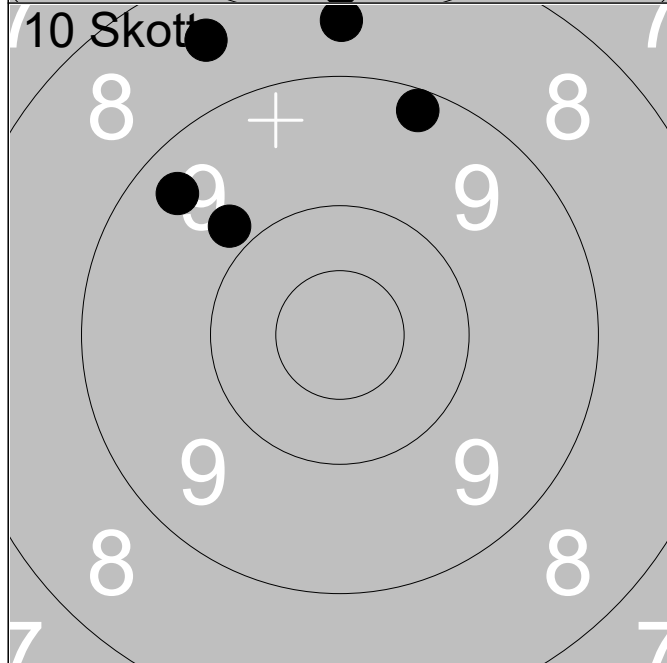

	6:	9.2	↑
	7:	9.8	↖
	8:	8.6	↑
	9:	8.5	↗
	10:	9.4	↘
Serie			43.0
Total			310.0

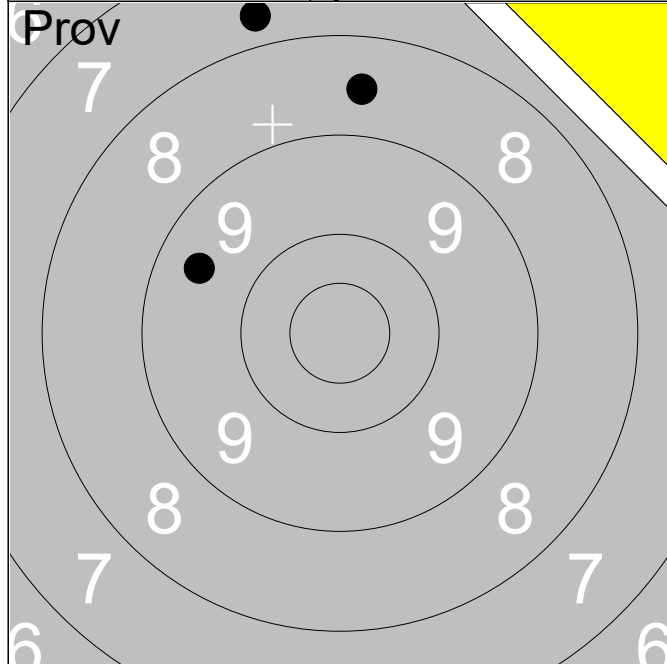

1:	7.7	↑
2:	8.6	↑
3:	9.5	↖

Serie	24.0
Total	220.0

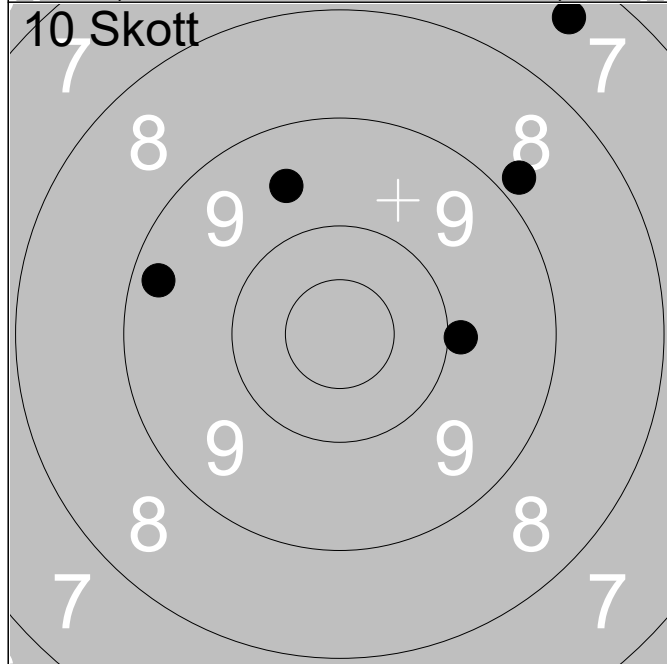

1:	9.3	↖
2:	8.8	↗
3:	7.4	↗
4:	9.9	→
5:	9.6	↑

Serie	42.0
Total	262.0

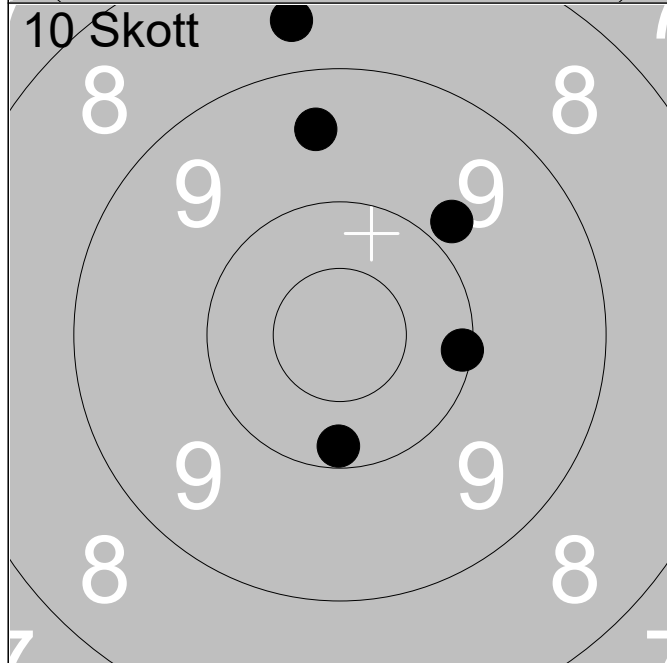

6:	9.8	↗
7:	10.1	→
8:	8.6	↑
9:	10.2	↓
10:	9.5	↑

Serie	46.0
Total	308.0

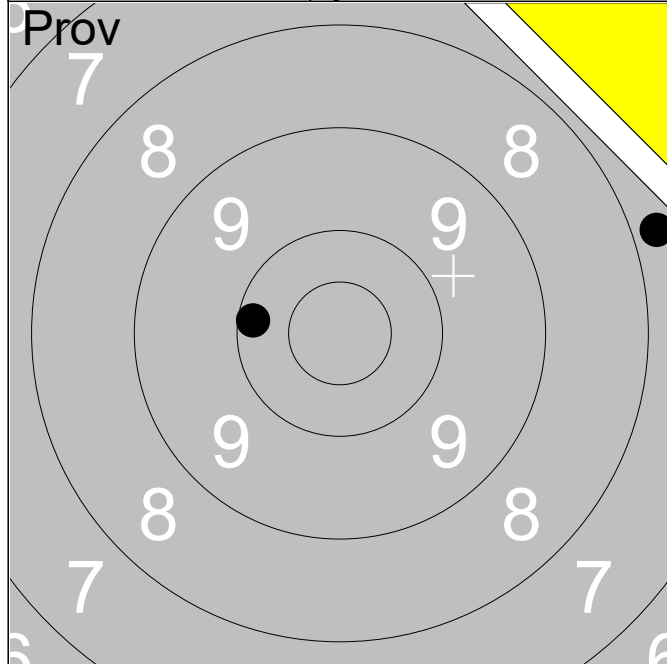

	1:	10.2	←
	2:	7.8	→
Serie			17.0
Total			216.0

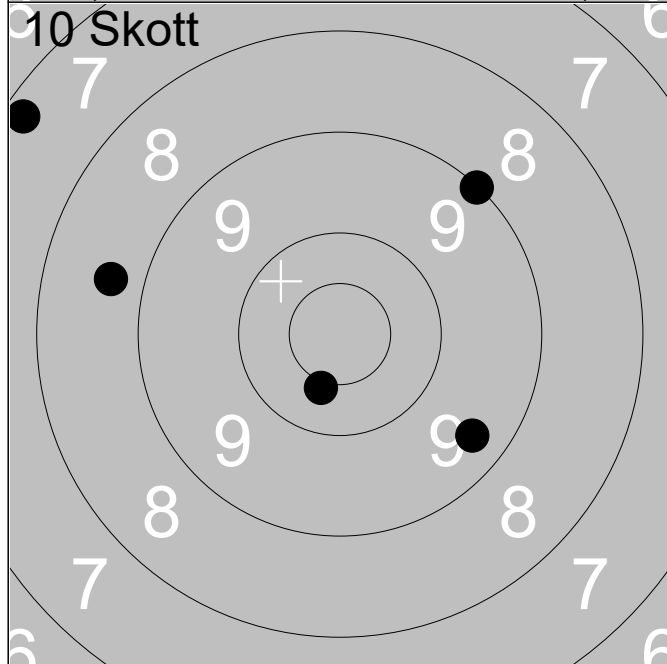

	1:	9.0	↗
	2:	10.4x	↘
	3:	7.2	↗
	4:	8.7	←
	5:	9.4	↘
Serie			43.0
Total			259.0

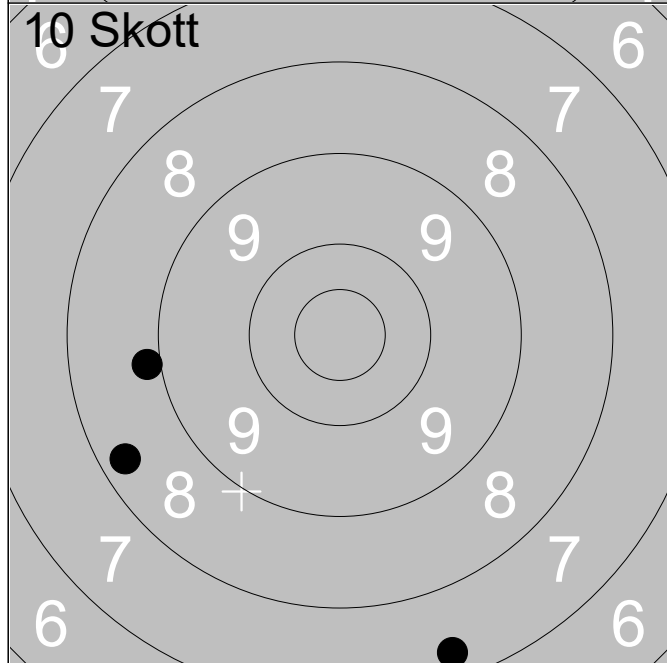

	6:	7.3	↘
	7:	8.3	←
	8:	8.9	←
Serie			23.0
Total			282.0

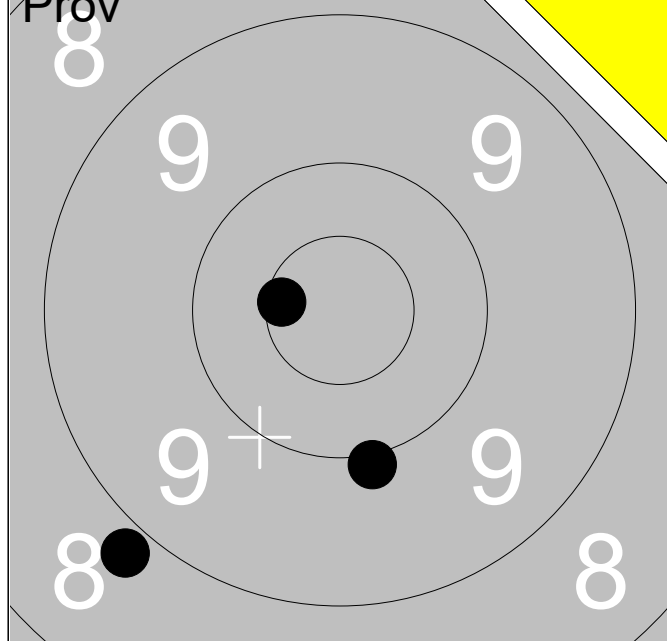

	1:	10.0	↓
	2:	8.8	↙
	3:	10.6x	←
Serie			28.0
Total			216.0

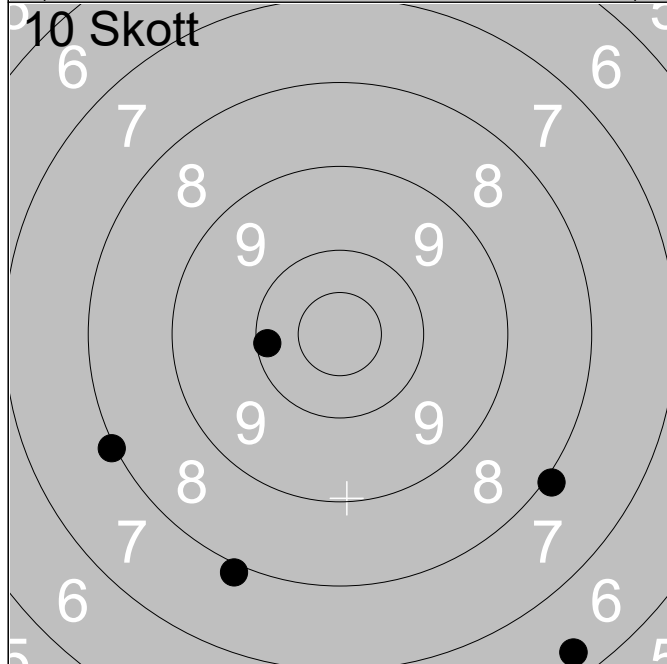

	1:	6.3	↓
	2:	7.9	↙
	3:	8.0	↘
	4:	10.1	←
	5:	8.0	↙
Serie			39.0
Total			255.0

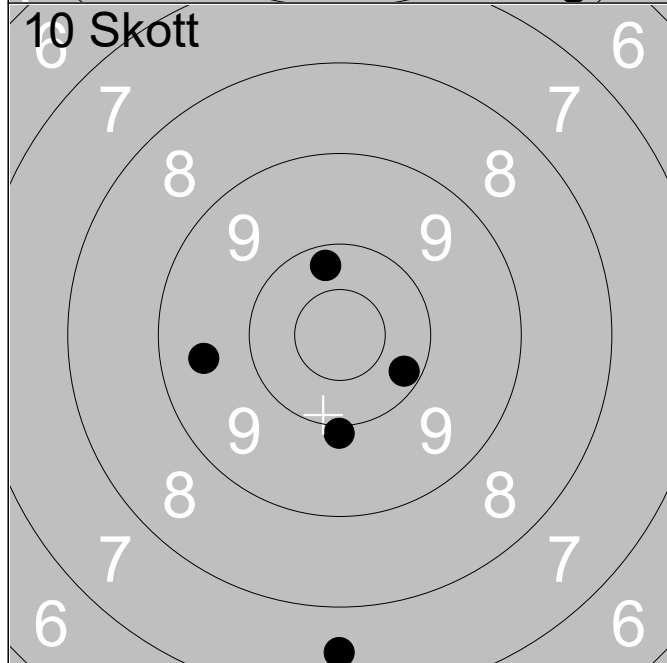

	6:	7.5	↓
	7:	10.2	↘
	8:	10.2	↑
	9:	9.5	←
	10:	9.9	↓
Serie			45.0
Total			300.0

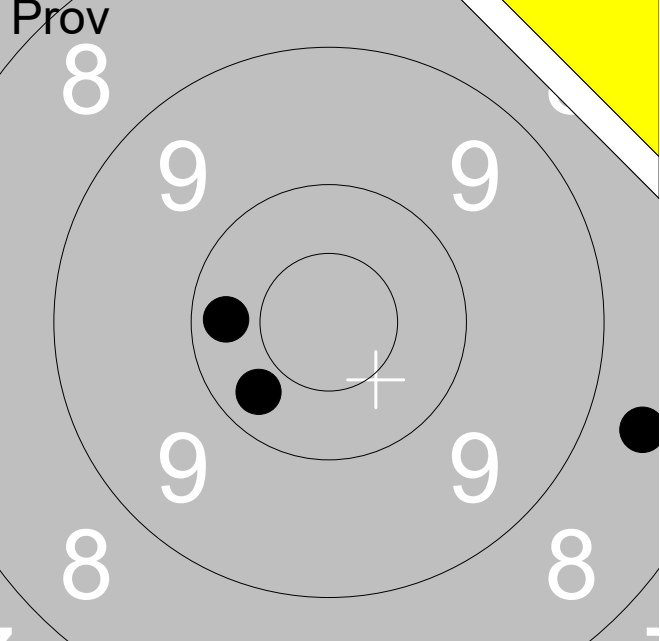
Prov 	1:	8.6	→
	2:	10.3	↙
	3:	10.3	←
	Serie		28.0
Total		212.0	

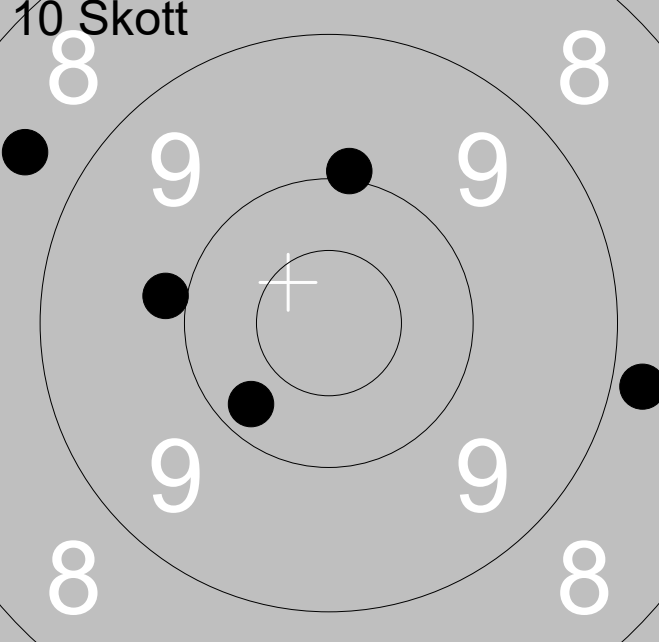
10 Skott 	1:	10.0	↑
	2:	8.8	→
	3:	10.2	↙
	4:	8.6	↗
	5:	9.9	←
	Serie		45.0
Total		257.0	

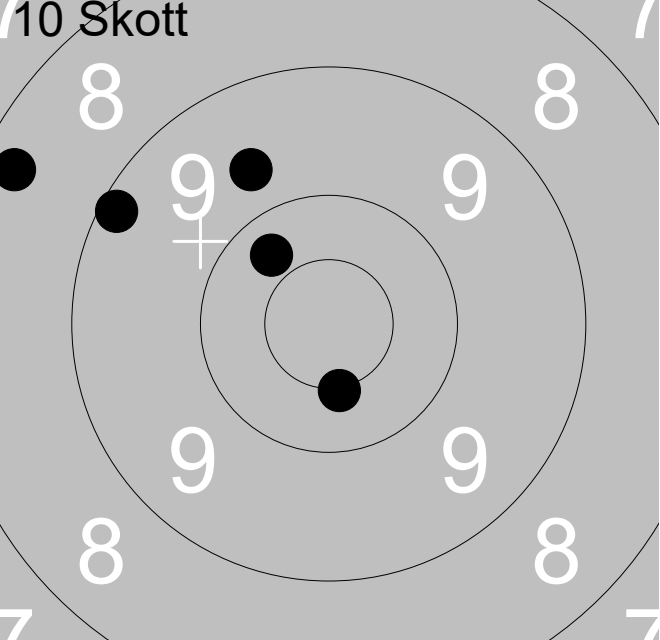
10 Skott 	6:	8.3	↗
	7:	10.5x	↘
	8:	9.7	↗
	9:	9.2	↗
	10:	10.3	↗
	Serie		46.0
Total		303.0	

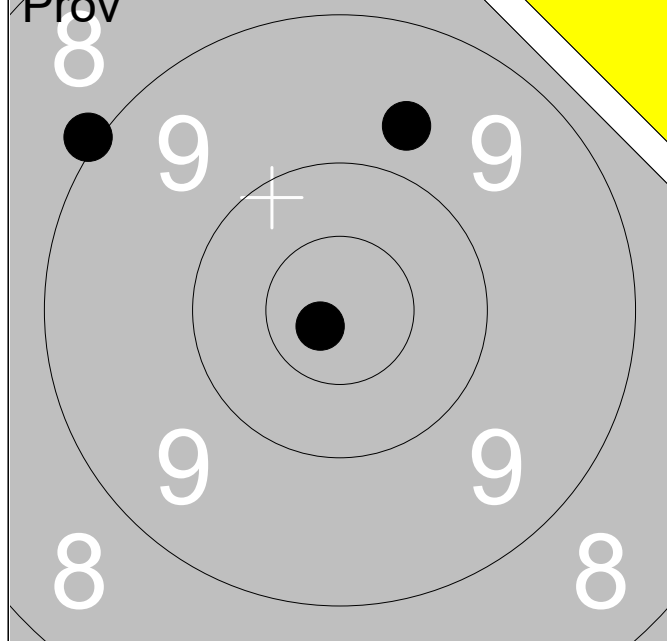

1:	9.0	↖
2:	9.7	↑
3:	10.8x	↙
Serie		28.0
Total		207.0

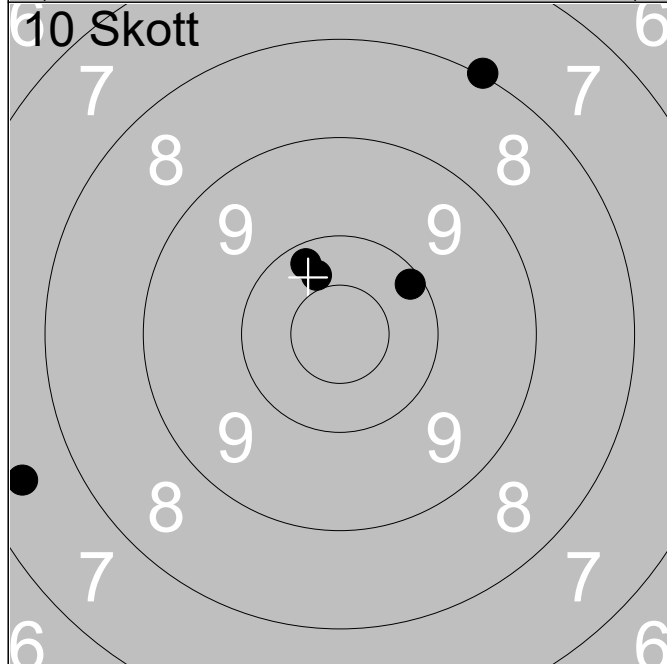

1:	10.2	↖
2:	10.4	↖
3:	8.0	↗
4:	7.5	↙
5:	10.1	↗
Serie		45.0
Total		252.0

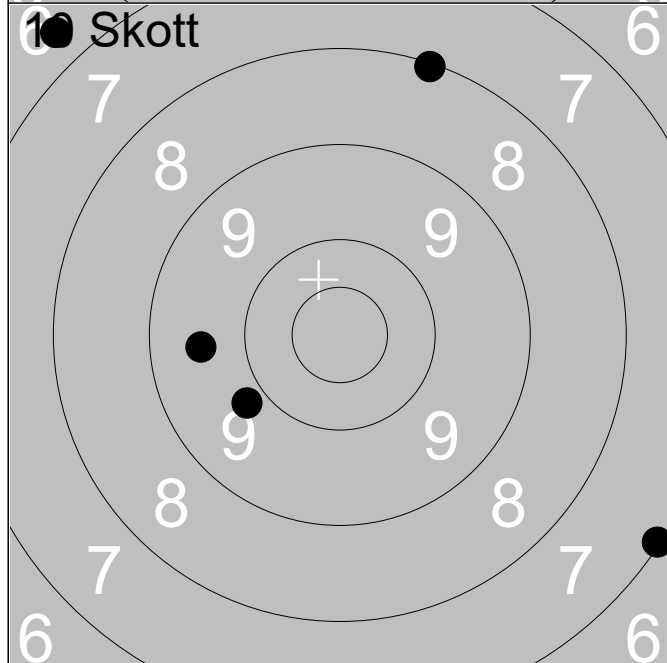

6:	9.8	↙
7:	8.1	↑
8:	7.1	↘
9:	9.6	↙
10:	6.7	↗
Serie		39.0
Total		291.0

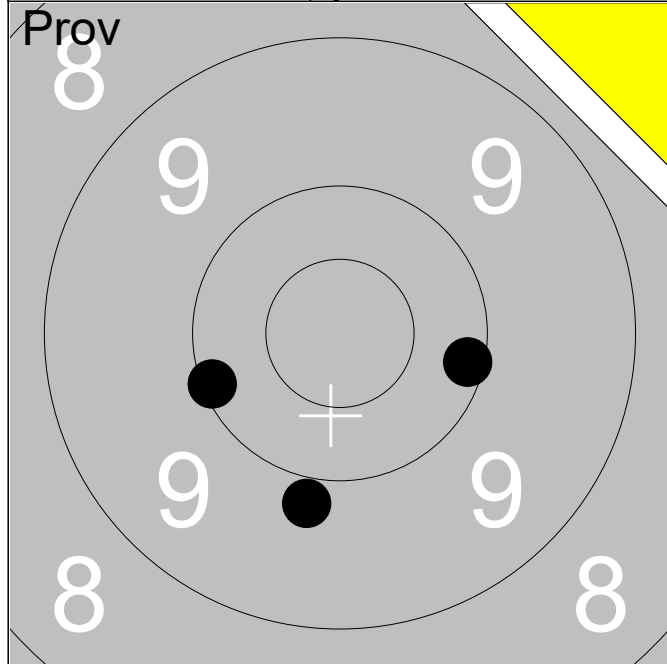

1:	10.1	→
2:	9.9	↓
3:	10.1	←
Serie		29.0
Total		205.0

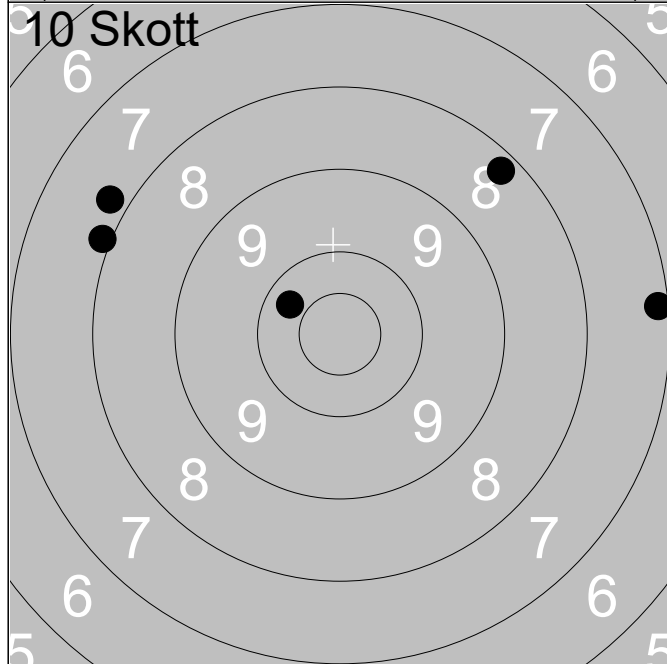

1:	7.8	↖
2:	10.3	↖
3:	8.2	↗
4:	7.9	←
5:	7.1	→
Serie		39.0
Total		244.0

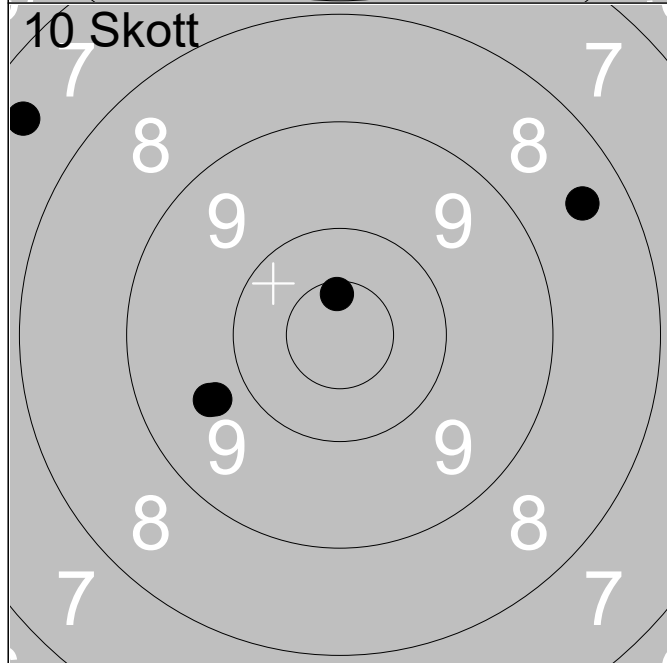

6:	7.4	↖
7:	9.7	←
8:	8.4	↗
9:	9.7	←
10:	10.6x	↑
Serie		43.0
Total		287.0

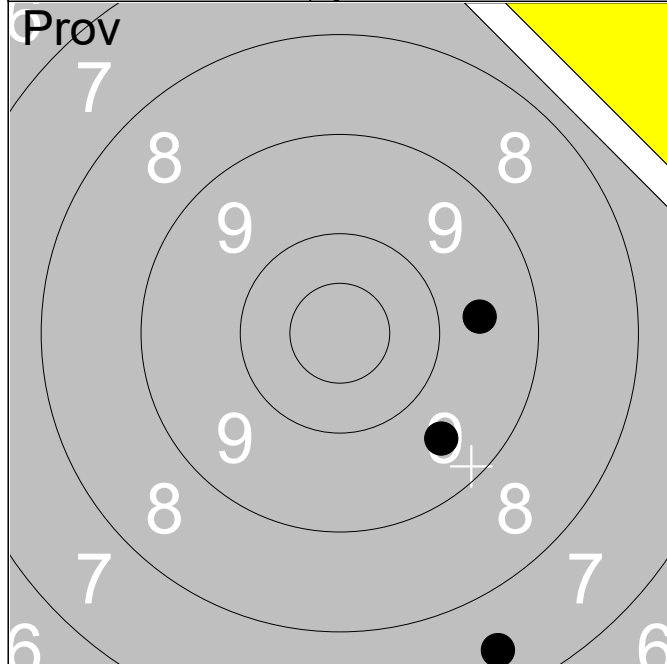

	1:	7.5			↘
	2:	9.6			↘
	3:	9.6			→
Serie					25.0
Total					236.0

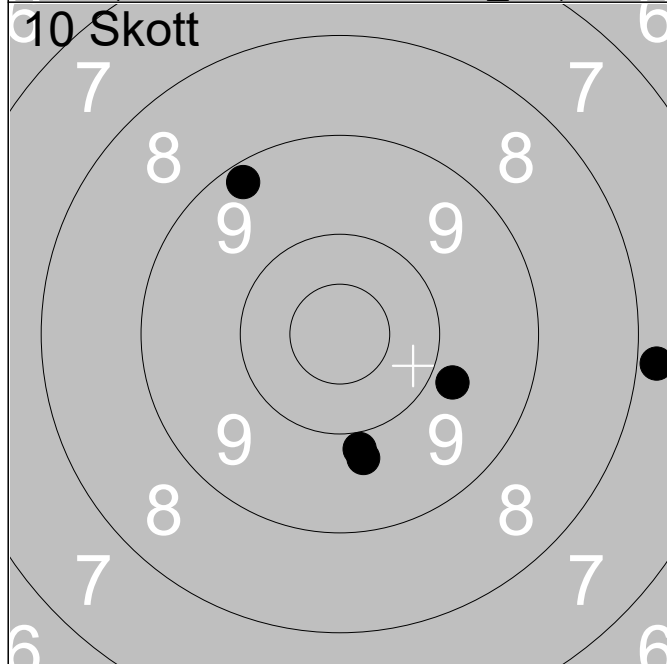

	1:	9.2			↗
	2:	7.8			→
	3:	9.8			↘
	4:	9.8			↘
	5:	9.9			↘
Serie					43.0
Total					279.0

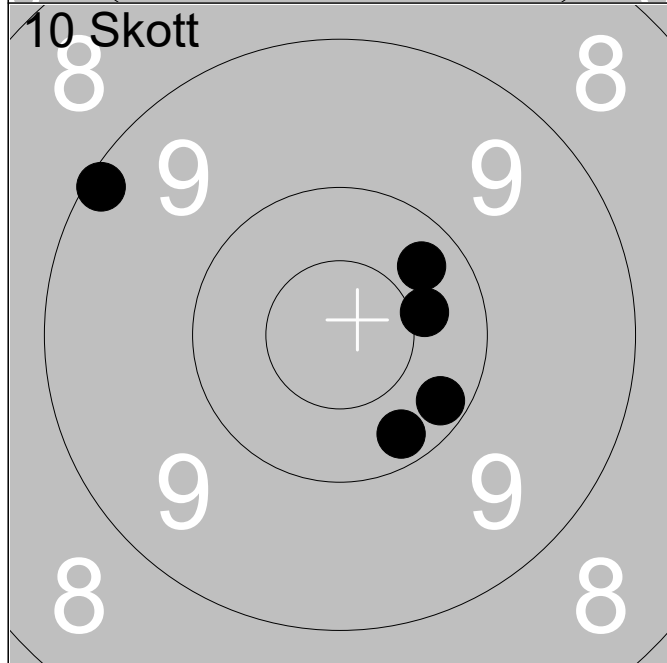

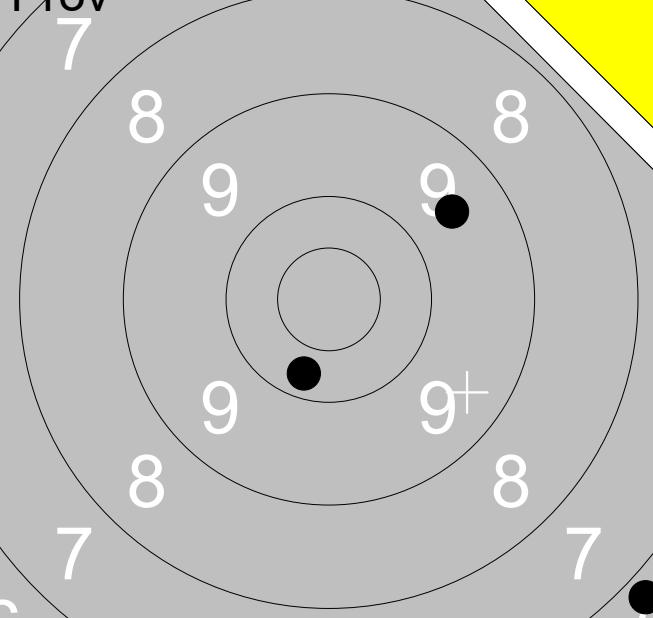

	6:	10.2			↘
	7:	10.4			→
	8:	10.3			↗
	9:	10.2			↘
	10:	9.1			↗
Serie					49.0
Total					328.0

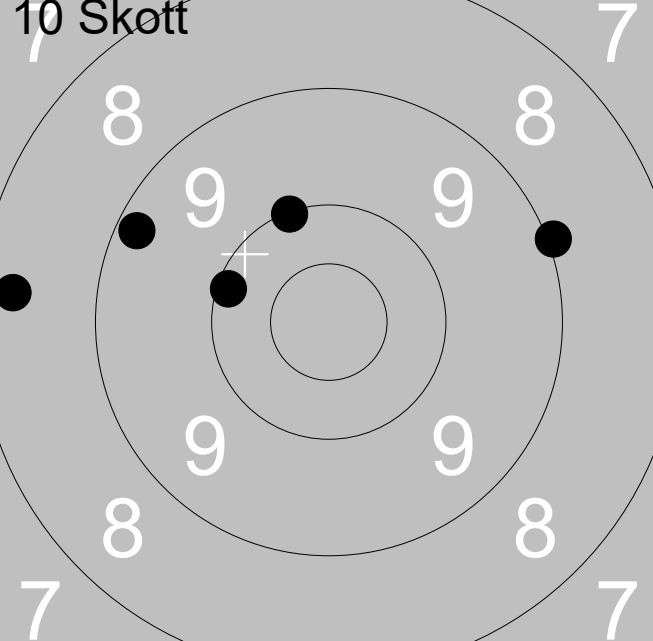
Prov 	1:	6.8	↘
	2:	9.6	↗
	3:	10.2	↘
	Serie		25.0
Total		228.0	

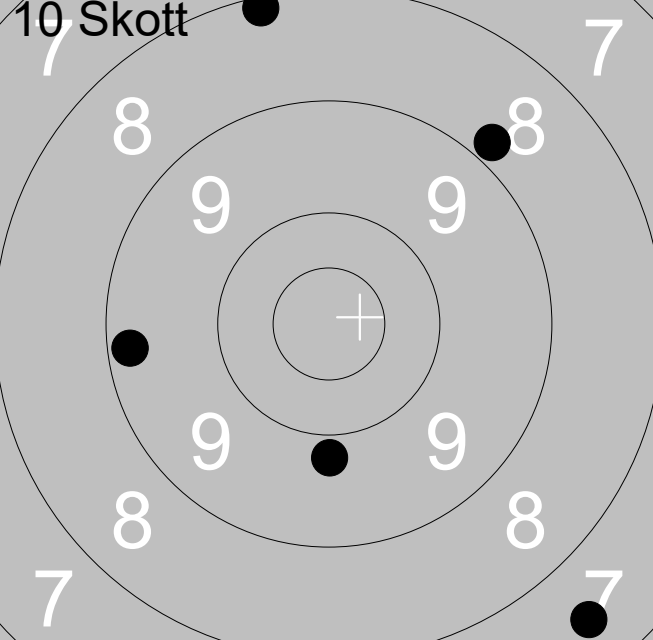
10 Skott 	1:	9.2	↖
	2:	9.0	↗
	3:	10.0	↖
	4:	10.1	↖
	5:	8.3	↖
	Serie		46.0
Total		274.0	

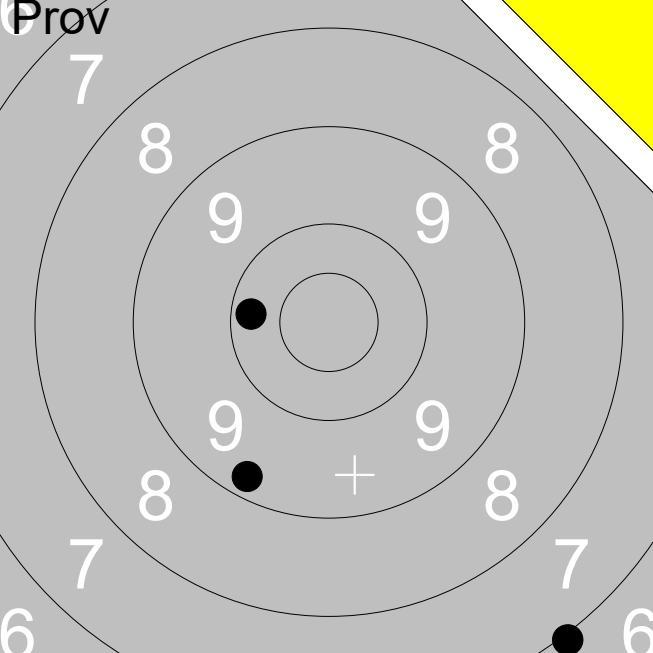
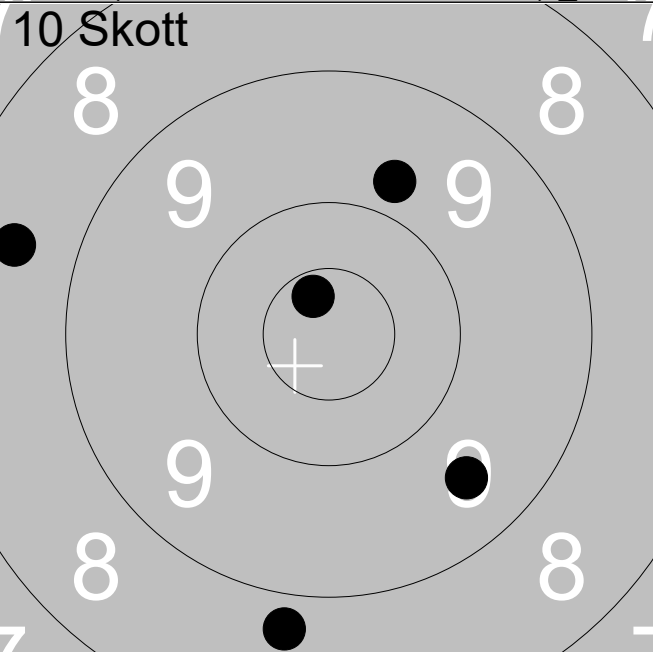
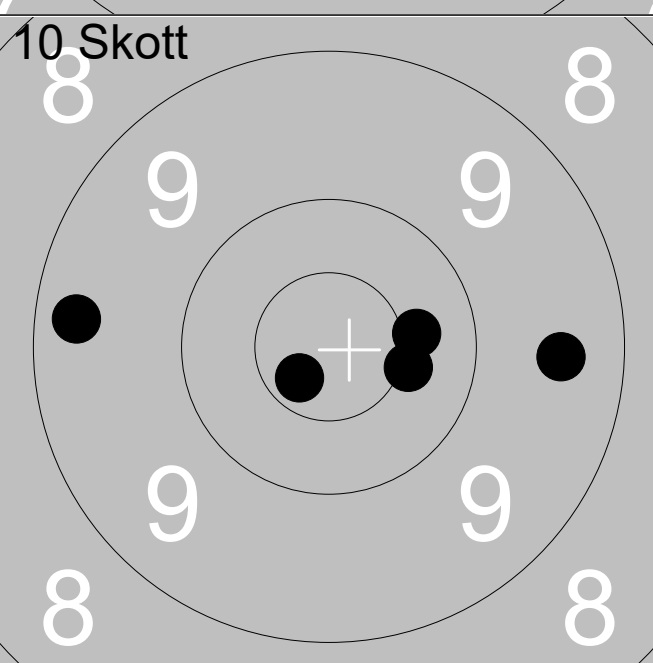
10 Skott 	6:	9.2	↖
	7:	8.1	↖
	8:	8.8	↗
	9:	7.5	↘
	10:	9.8	↘
	Serie		41.0
Total		315.0	

13.07.2023	Björkskottet 2023	Ramselefors SKF
		1: 9.3 ↘
		2: 10.2 ←
		3: 7.0 ↘
		Serie 26.0
		Total 227.0
		Serie 44.0
		1: 9.8 ↗
		2: 8.8 ↘
		3: 8.5 ←
		4: 10.7x ↗
		5: 9.5 ↘
		Serie 48.0
		Total 271.0
		Serie 48.0
		6: 9.3 ←
		7: 10.4 →
		8: 10.4x →
		9: 9.5 →
		10: 10.7x ↘
		Serie 48.0
		Total 319.0
		Serie 48.0

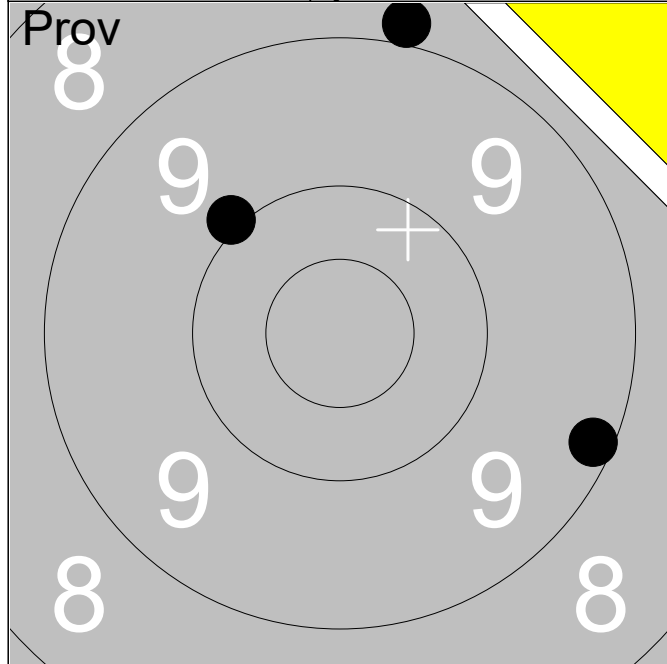

1:	8.9	↑
2:	10.0	↗
3:	9.2	↘
Serie		27.0
Total		227.0

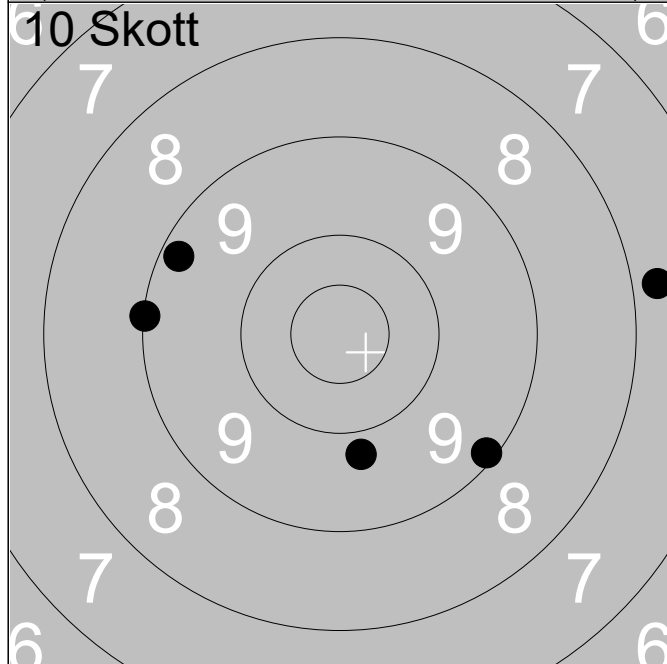

1:	9.1	←
2:	7.8	→
3:	9.1	↘
4:	9.2	↗
5:	9.8	↘
Serie		43.0
Total		270.0

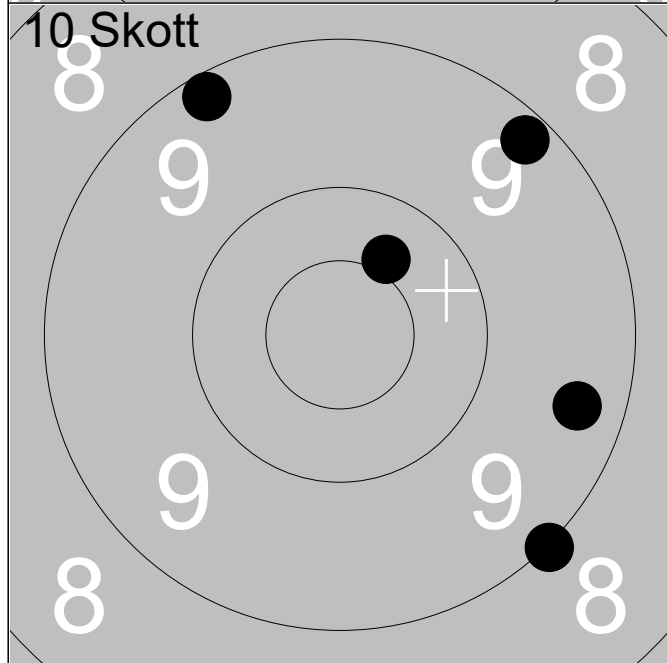

6:	9.2	↗
7:	9.2	↗
8:	10.4	↗
9:	9.0	↘
10:	9.4	→
Serie		46.0
Total		316.0

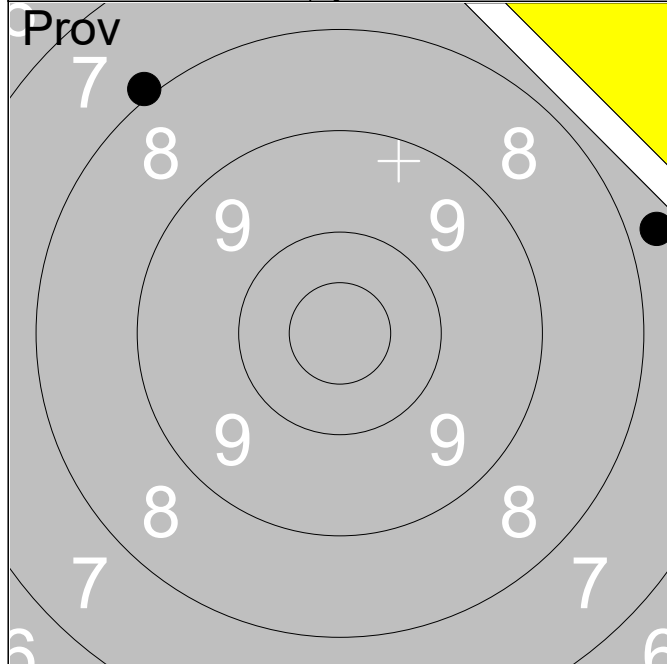

	1:	7.9	↖
	2:	7.7	→

Serie	14.0
Total	226.0

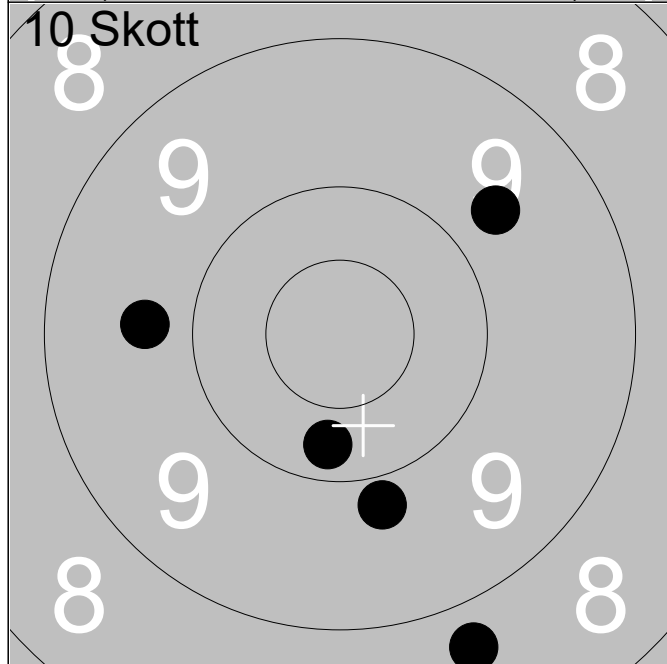

	1:	9.7	←
	2:	10.3	↓
	3:	9.8	↓
	4:	8.7	↓
	5:	9.7	↗

Serie	45.0
Total	271.0

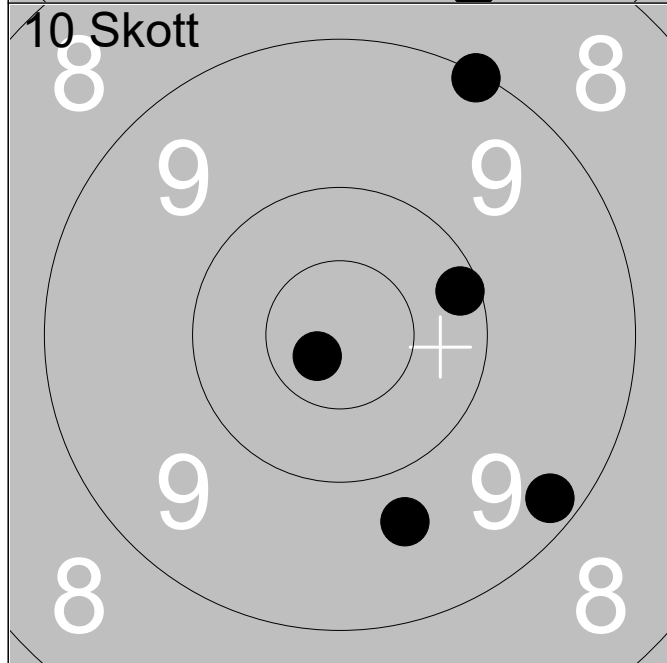

	6:	9.1	↗
	7:	10.1	→
	8:	9.2	↘
	9:	9.7	↓
	10:	10.8x	↖

Serie	47.0
Total	318.0

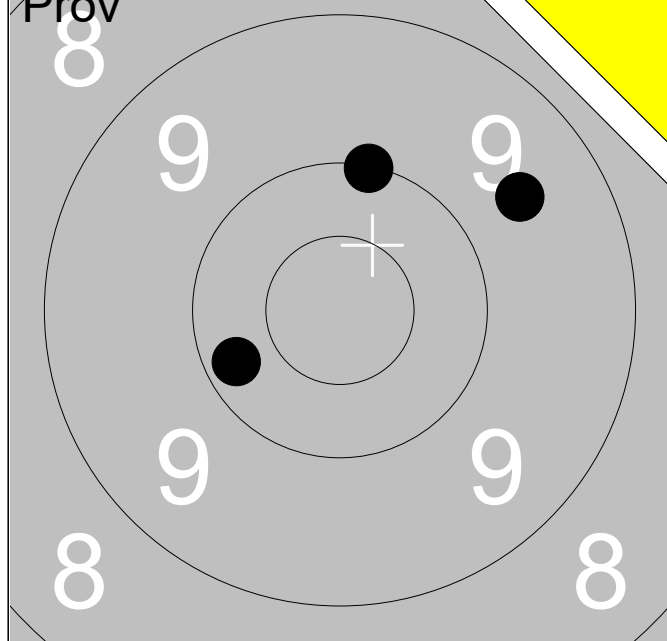

	1:	9.6	↗
	2:	10.0	↑
	3:	10.2	↖
Serie			29.0
Total			226.0

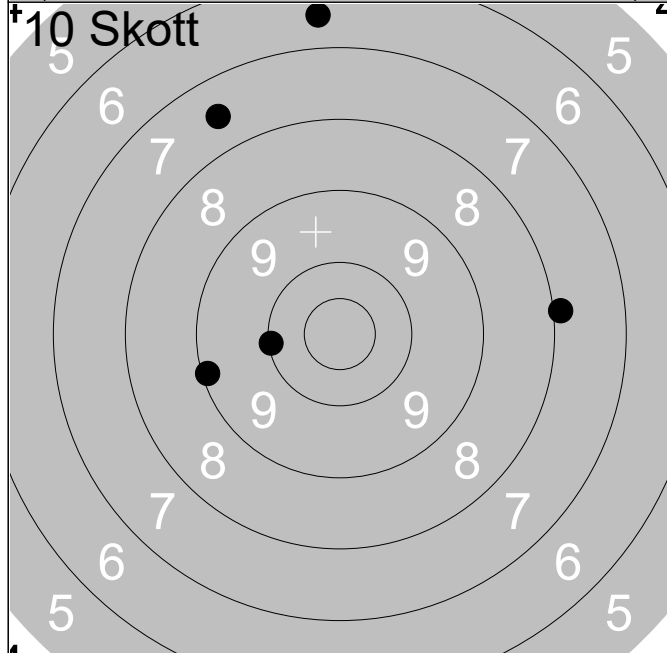

	1:	6.6	↑
	2:	7.5	↖
	3:	7.9	→
	4:	9.1	↖
	5:	10.1	↖
Serie			39.0
Total			265.0

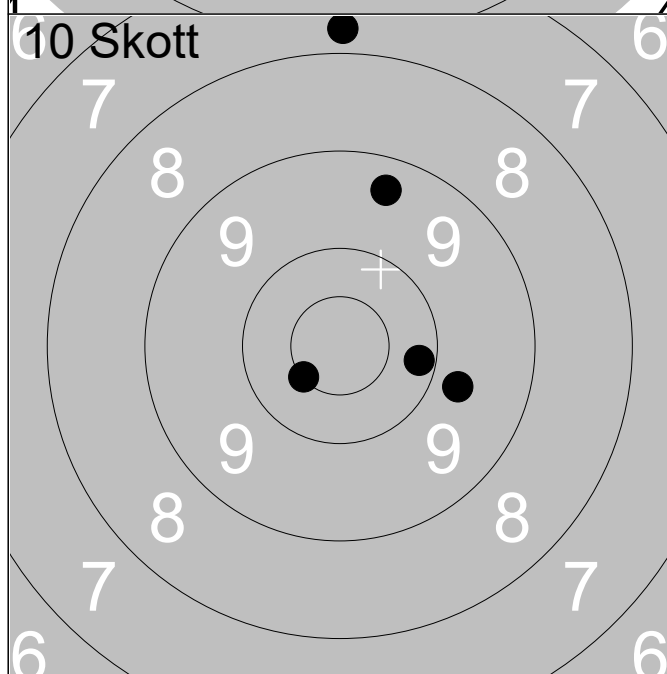

	6:	7.8	↑
	7:	10.2	→
	8:	9.4	↑
	9:	9.8	→
	10:	10.5x	↖
Serie			45.0
Total			310.0

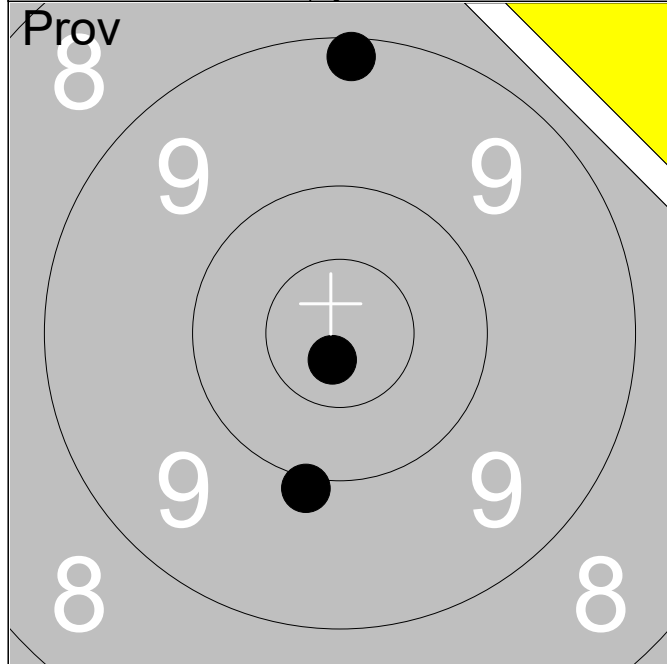

1:	10.8x	↓
2:	9.2	↑
3:	10.0	↓
Serie		29.0
Total		225.0

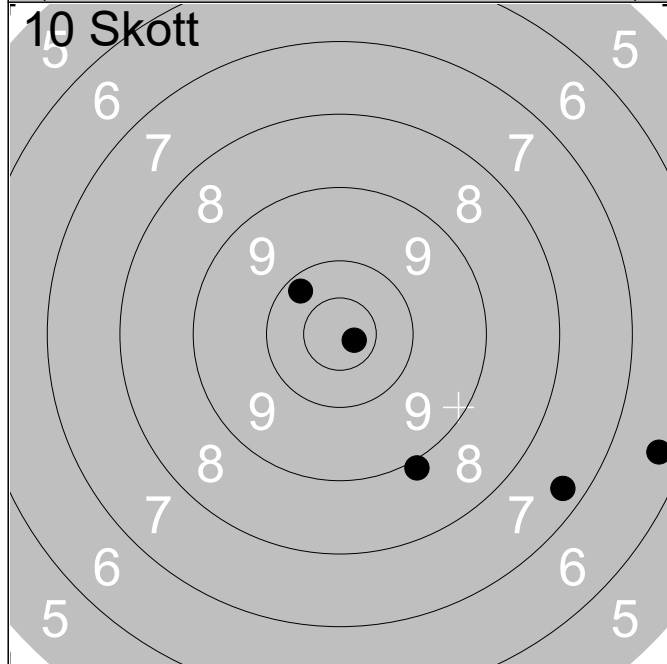

1:	7.3	↘
2:	6.4	→
3:	8.9	↘
4:	10.8x	↘
5:	10.2	↗
Serie		41.0
Total		266.0

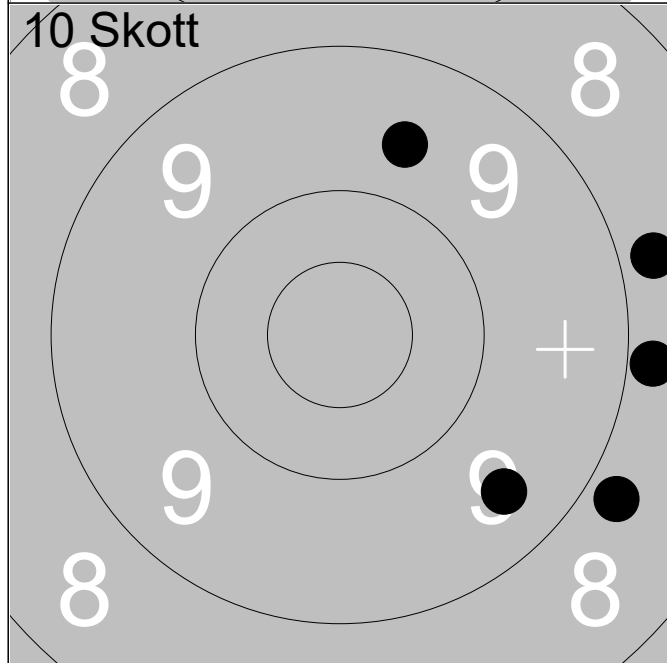

6:	8.8	↘
7:	9.5	↘
8:	8.8	→
9:	9.6	↑
10:	8.9	→
Serie		42.0
Total		308.0

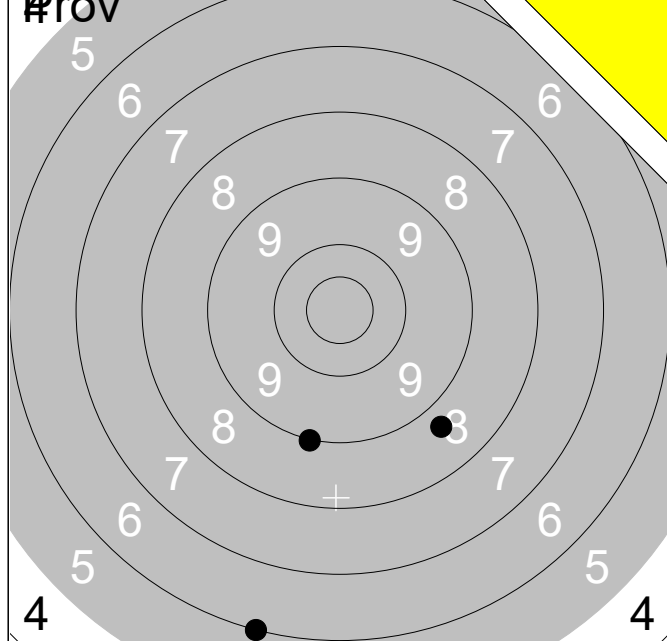

	1:	9.0	↓
	2:	8.7	↓
	3:	6.0	↓
Serie			23.0
Total			225.0

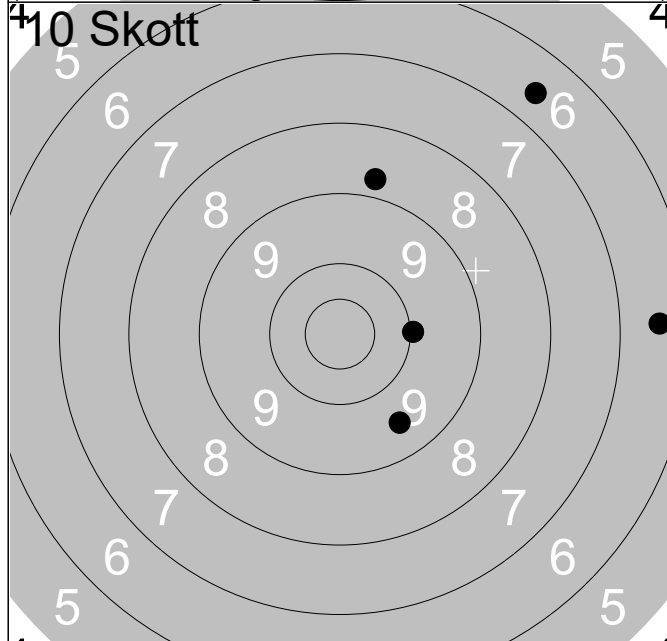

	1:	9.5	↓
	2:	10.0	→
	3:	6.5	→
	4:	6.6	↗
	5:	8.8	↑
Serie			39.0
Total			264.0

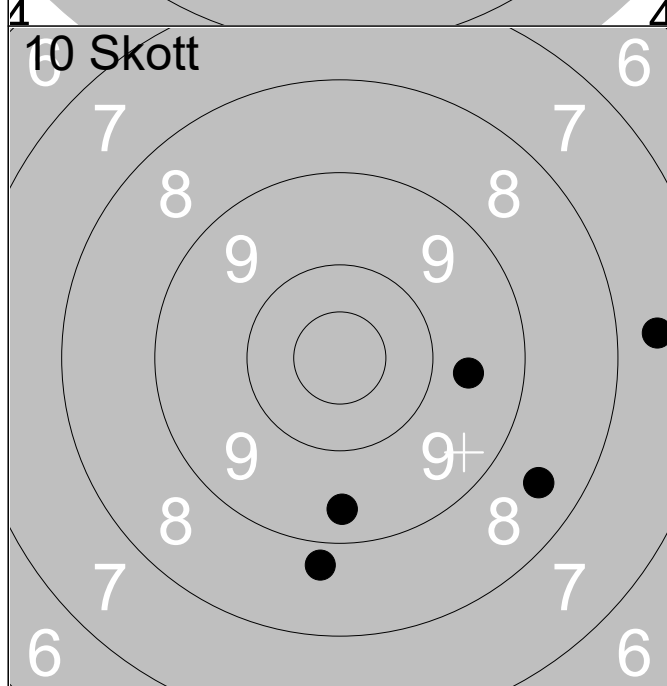

	6:	7.6	→
	7:	8.5	↓
	8:	8.8	↓
	9:	9.4	↓
	10:	9.6	→
Serie			41.0
Total			305.0

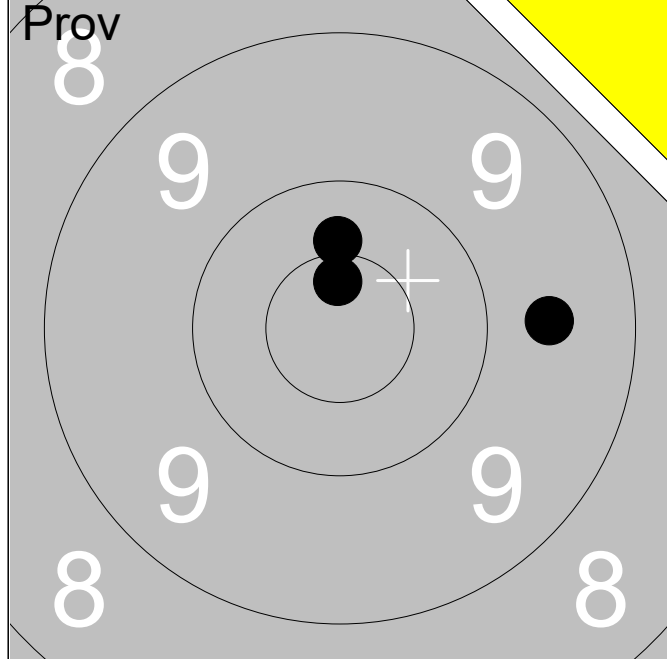

	1:	9.6	→
	2:	10.7x	↑
	3:	10.4	↑
Serie			29.0
Total			223.0

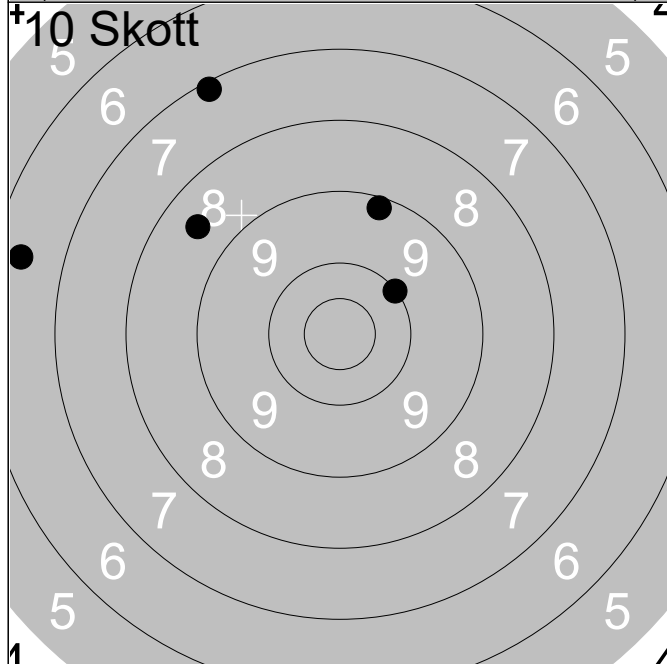

	1:	7.1	↖
	2:	6.4	←
	3:	9.2	↑
	4:	8.5	↖
	5:	10.0	↗
Serie			40.0
Total			263.0

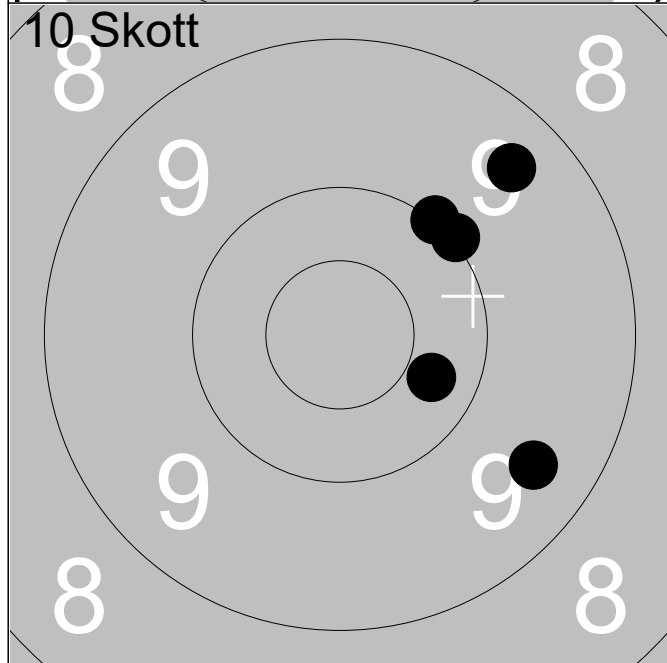

	6:	9.4	↗
	7:	10.0	↗
	8:	10.3	→
	9:	9.5	↘
	10:	10.0	↗
Serie			48.0
Total			311.0

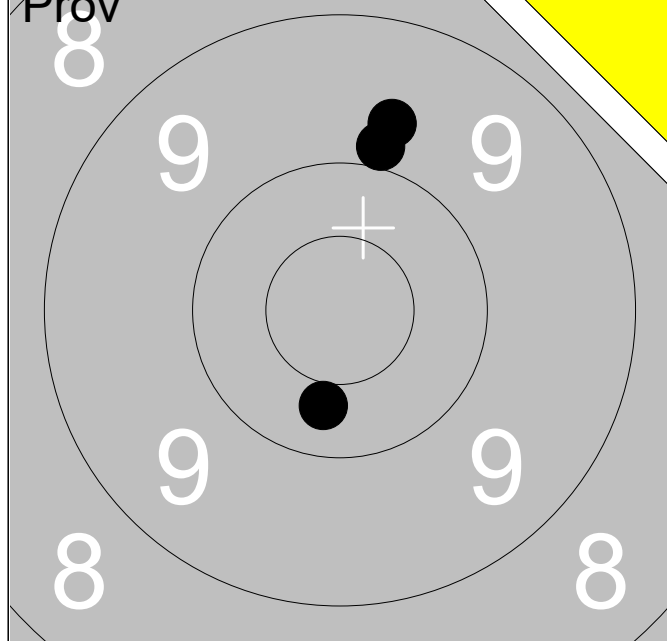

	1:	9.7	↑
	2:	9.9	↑
	3:	10.3	↓
Serie			28.0
Total			222.0

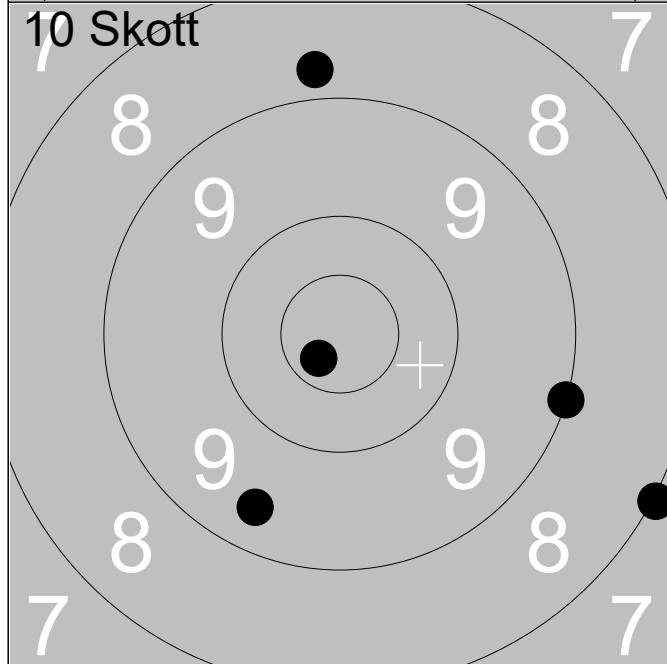

	1:	10.7x	↙
	2:	9.0	→
	3:	8.8	↑
	4:	9.4	↘
	5:	8.0	→
Serie			44.0
Total			266.0

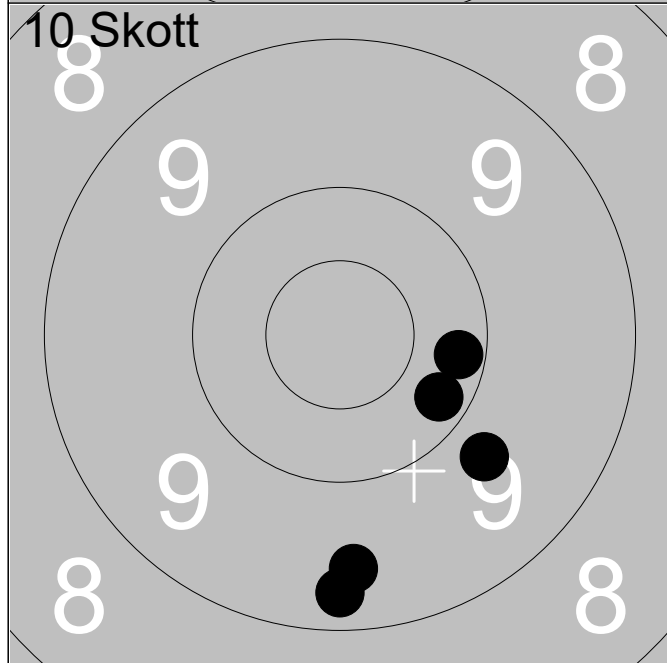

	6:	9.3	↓
	7:	10.2	↘
	8:	9.4	↓
	9:	10.2	→
	10:	9.8	↘
Serie			47.0
Total			313.0

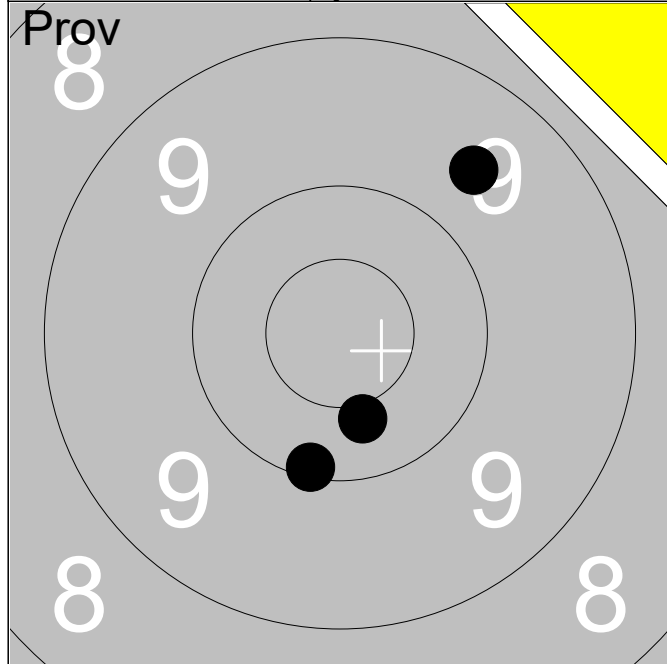

	1:	10.1	↓
	2:	10.4	↓
	3:	9.6	↗
Serie			29.0
Total			222.0

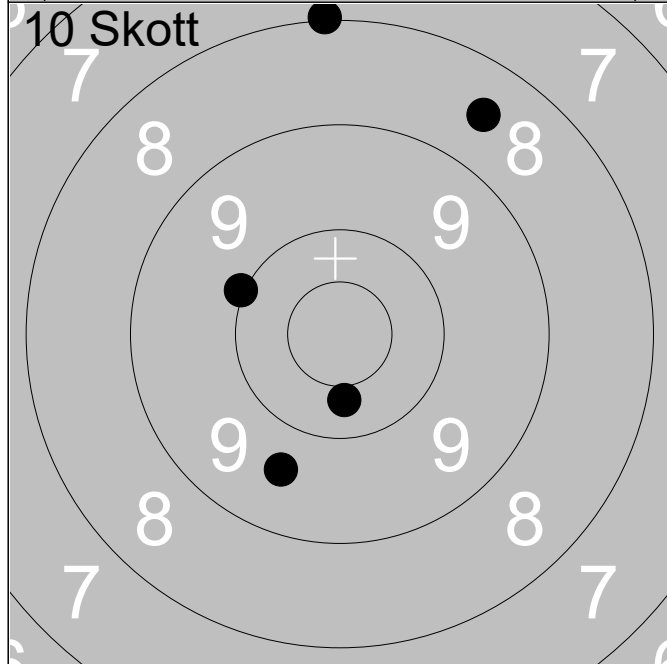

	1:	10.0	↖
	2:	8.5	↗
	3:	8.0	↑
	4:	10.4	↓
	5:	9.6	↘
Serie			45.0
Total			267.0

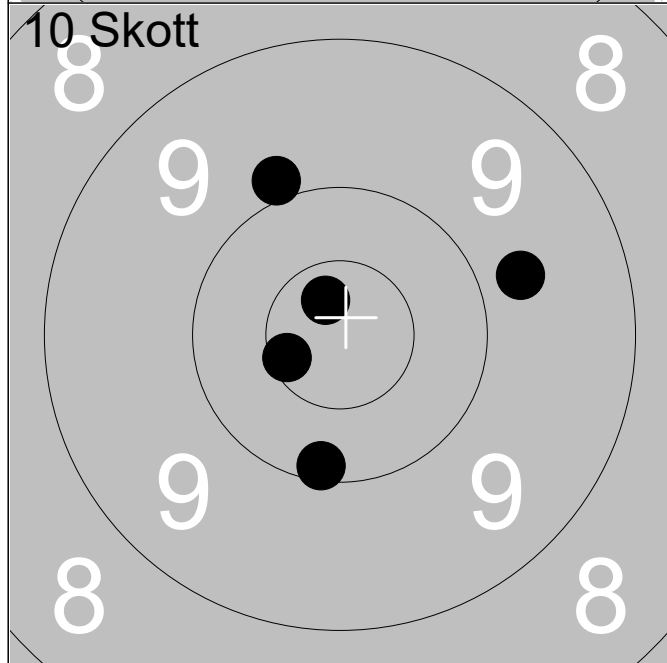

	6:	10.1	↓
	7:	9.9	↗
	8:	10.7x	↗
	9:	9.7	→
	10:	10.6x	↖
Serie			48.0
Total			315.0

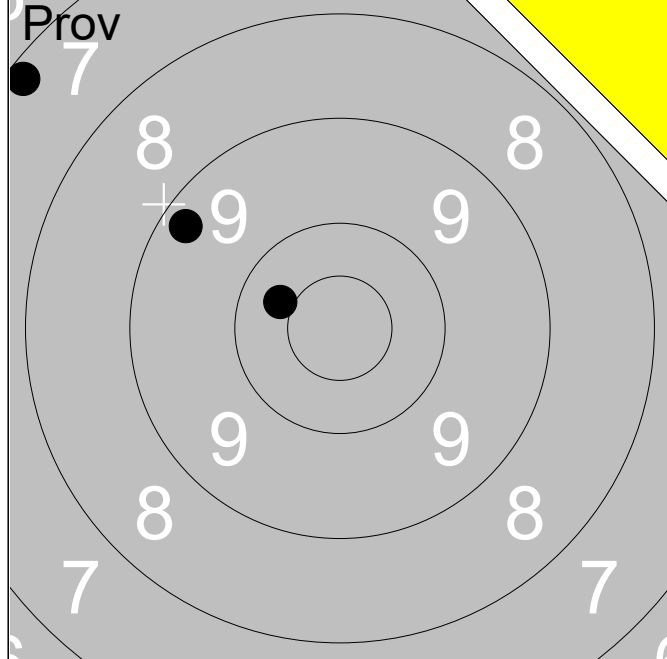

	1:	10.4	↗
	2:	9.3	↗
	3:	7.2	↗
Serie			26.0
Total			219.0

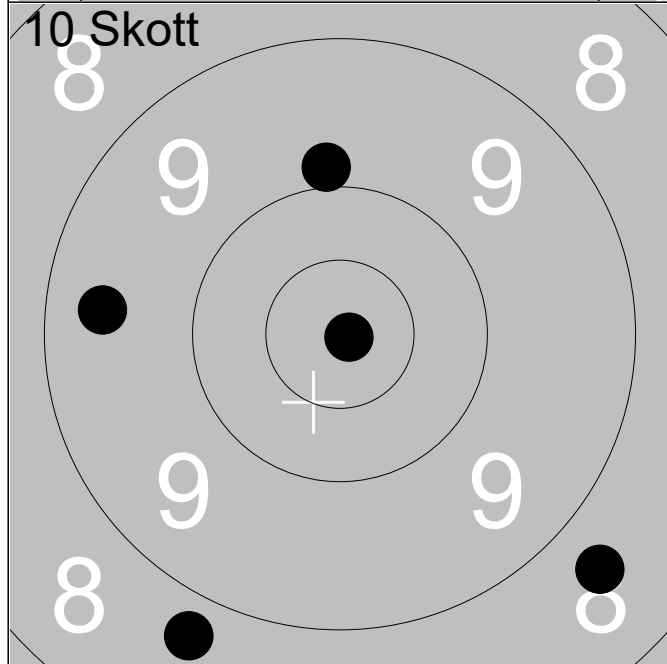

	1:	9.9	↑
	2:	8.7	↘
	3:	8.7	↘
	4:	9.4	←
	5:	10.9x	→
Serie			44.0
Total			263.0

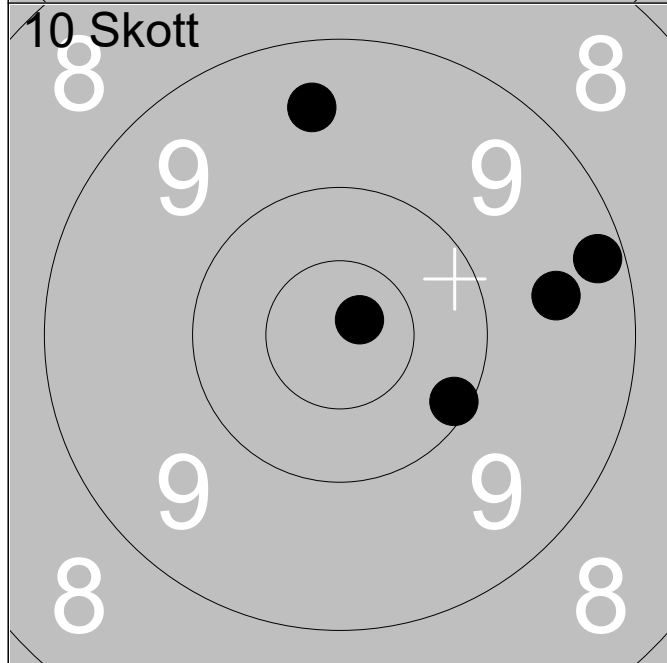

	6:	9.5	↑
	7:	10.8x	↗
	8:	9.5	→
	9:	9.2	→
	10:	10.1	→
Serie			47.0
Total			310.0

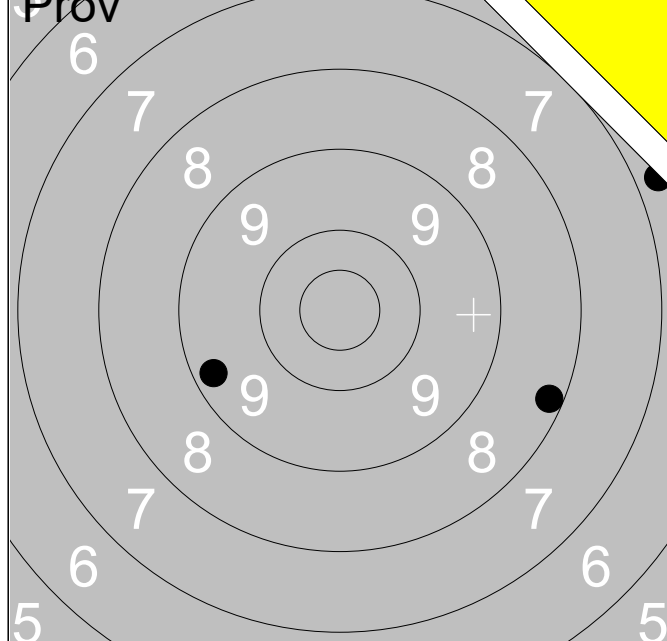

	1:	9.3	↙
	2:	8.2	→
	3:	6.7	→
Serie			23.0
Total			219.0

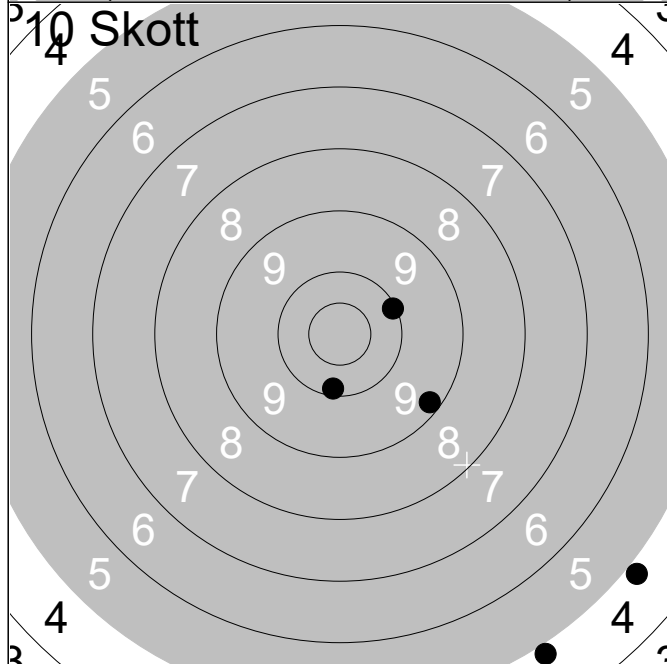

	1:	4.9	↘
	2:	10.1	↗
	3:	4.8	↘
	4:	10.1	↘
	5:	9.2	↘
Serie			37.0
Total			256.0

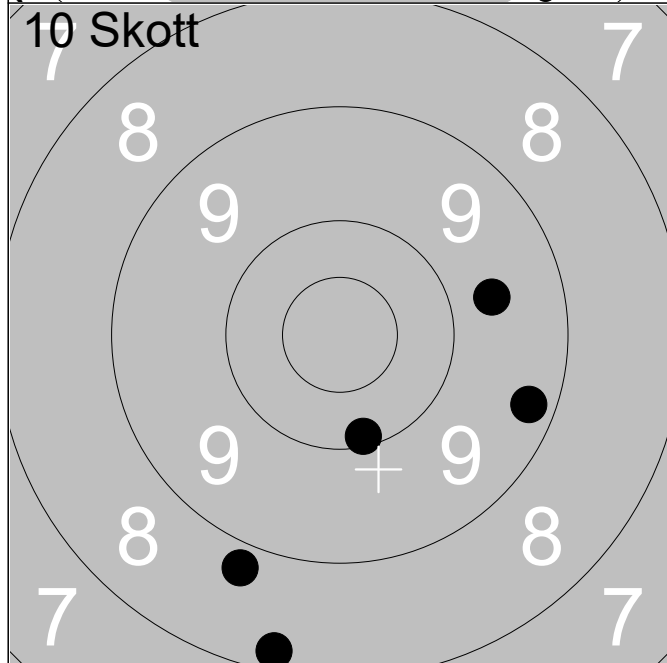

	6:	9.7	→
	7:	8.2	↘
	8:	9.3	→
	9:	10.1	↘
	10:	8.8	↘
Serie			44.0
Total			300.0

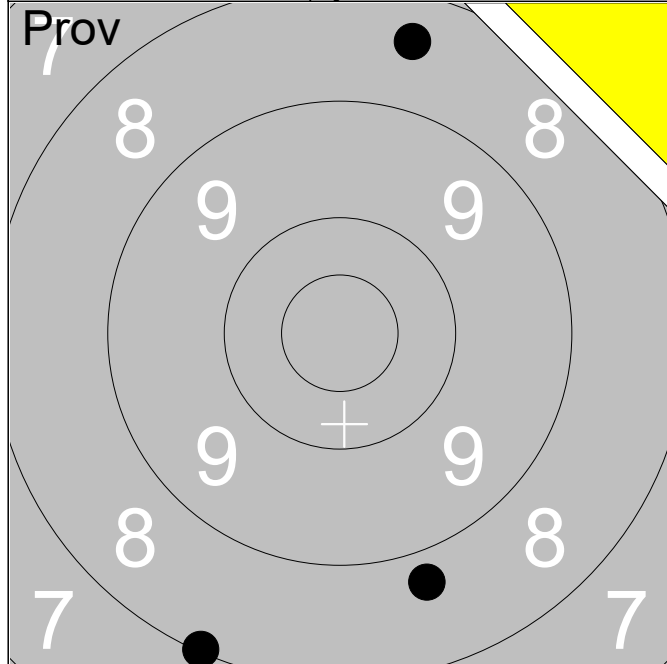

1:	8.4	↑
2:	8.1	↓
3:	8.8	↓
Serie		24.0
Total		215.0

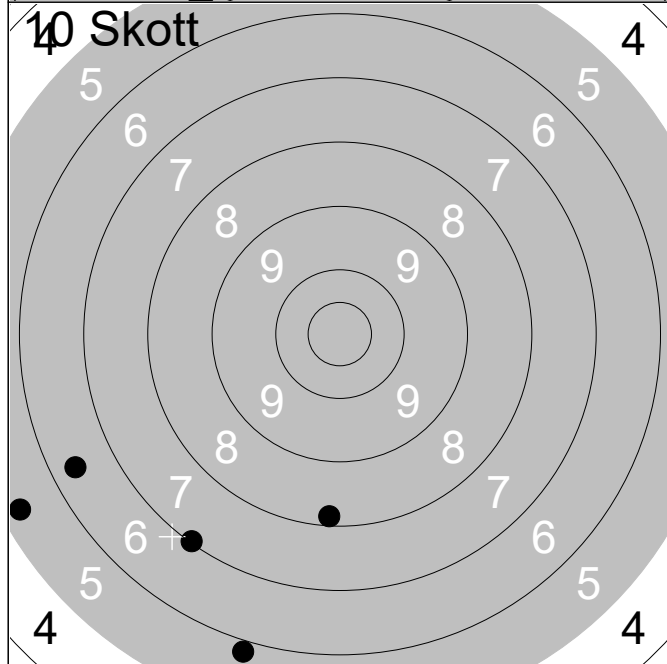

1:	5.8	↓
2:	6.4	←
3:	7.1	↓
4:	5.3	←
5:	8.2	↓
Serie		31.0
Total		246.0

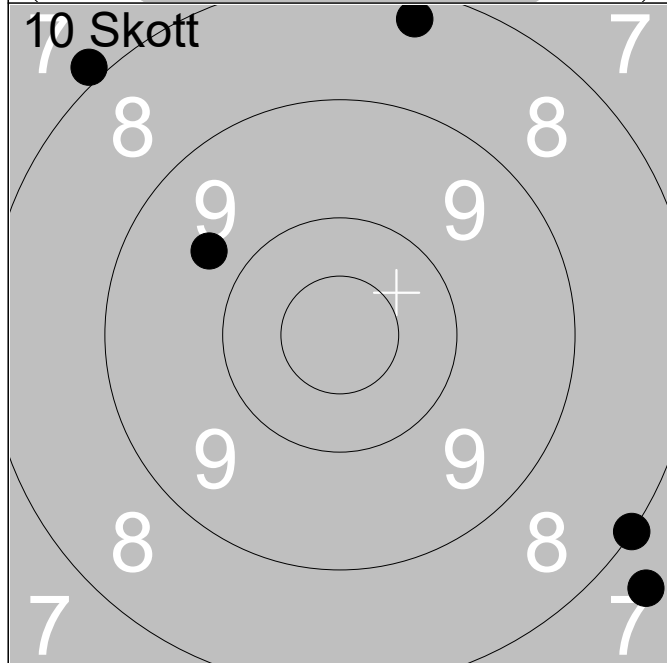

6:	7.6	↓
7:	9.7	↗
8:	8.3	↑
9:	7.9	↗
10:	8.0	↓
Serie		39.0
Total		285.0

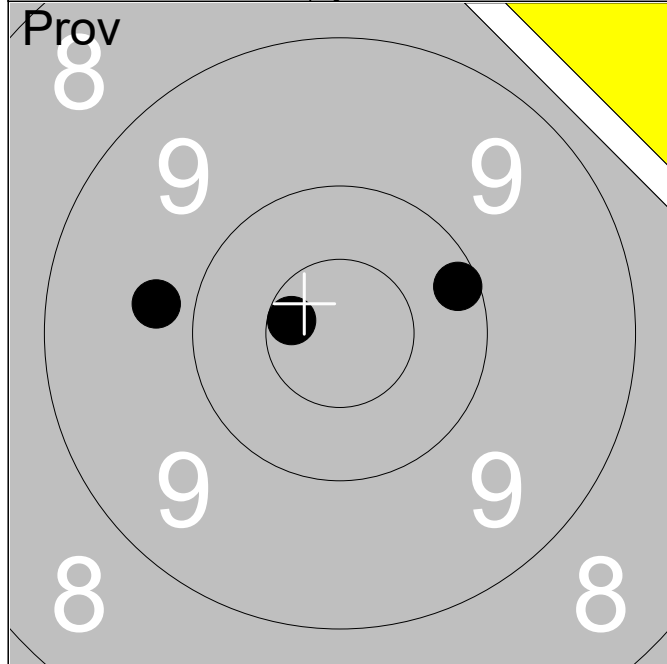

1:	9.8	←
2:	10.2	→
3:	10.6x	←
Serie		29.0
Total		225.0

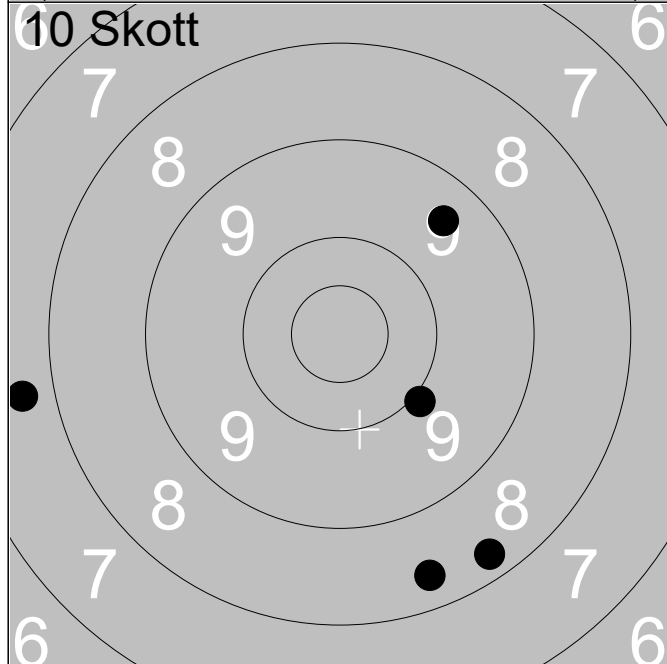

1:	7.7	←
2:	9.4	↗
3:	8.4	↓
4:	10.0	↓
5:	8.3	↓
Serie		42.0
Total		267.0

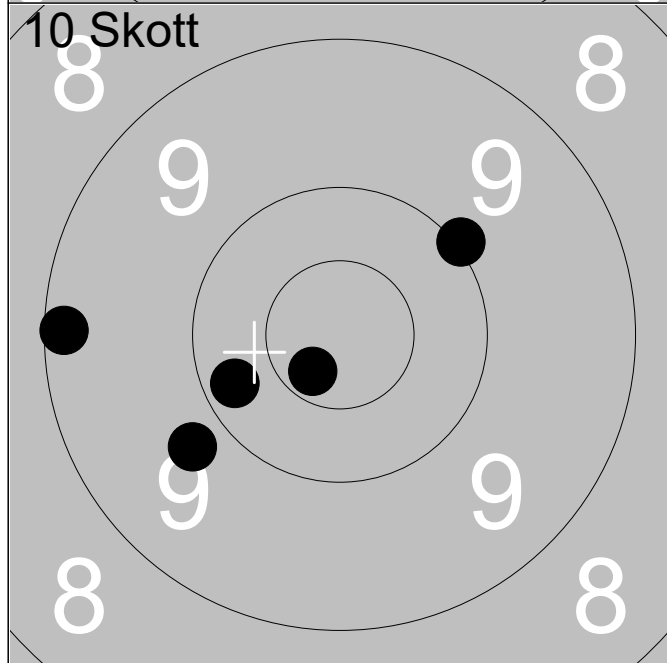

6:	9.2	←
7:	10.7x	↙
8:	9.8	↙
9:	10.2	←
10:	10.0	↗
Serie		48.0
Total		315.0

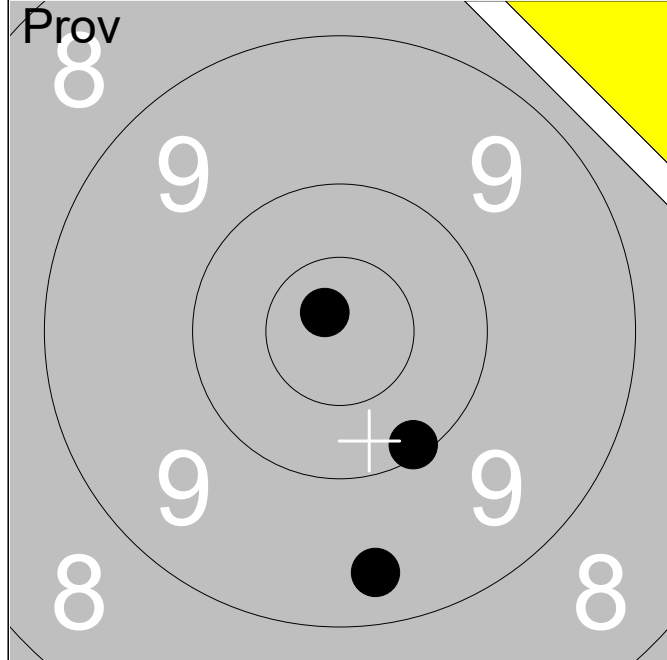

1:	10.8x	↗
2:	10.1	↘
3:	9.4	↘
Serie		29.0
Total		225.0

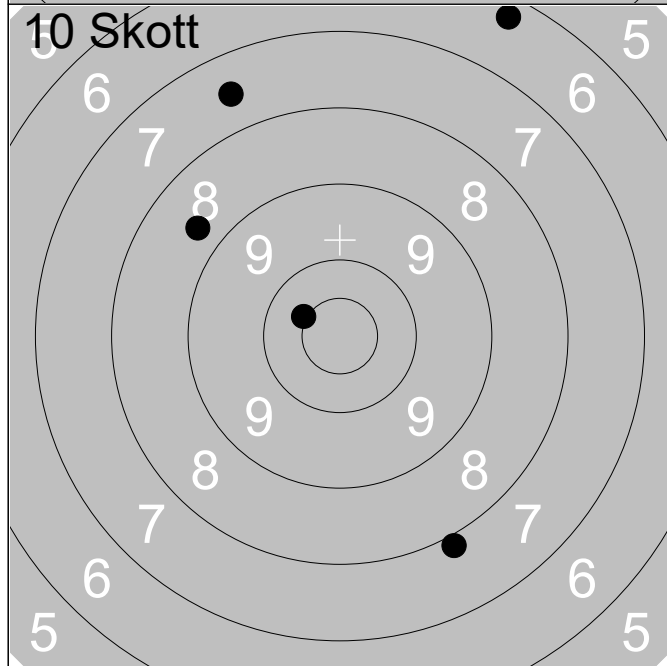

1:	6.3	↗
2:	10.4x	↗
3:	8.7	↗
4:	7.5	↗
5:	7.9	↘
Serie		38.0
Total		263.0

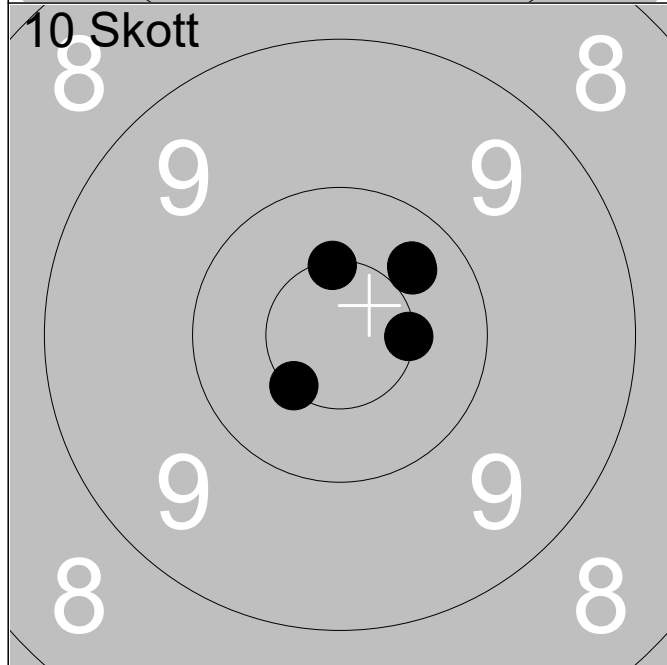

6:	10.3	↗
7:	10.5x	↑
8:	10.3	↗
9:	10.5x	↘
10:	10.5x	→
Serie		50.0
Total		313.0

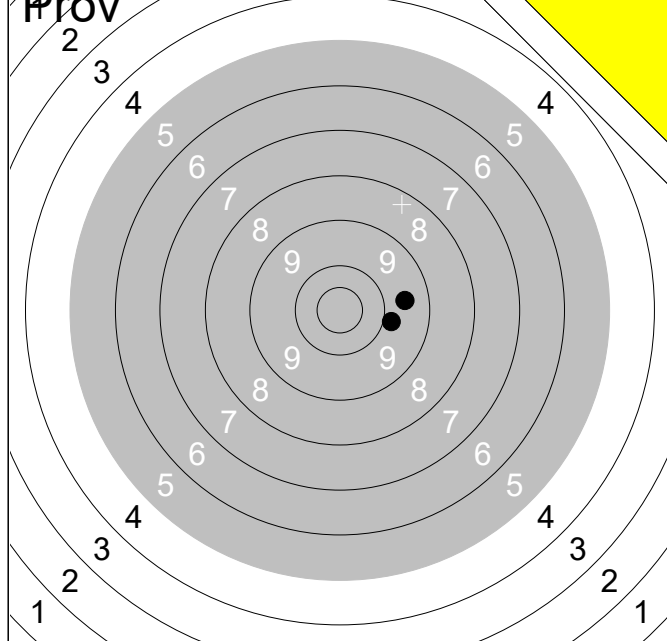

	1:	9.9	→
	2:	9.6	→
	3:	3.7	↑
Serie			21.0
Total			217.0

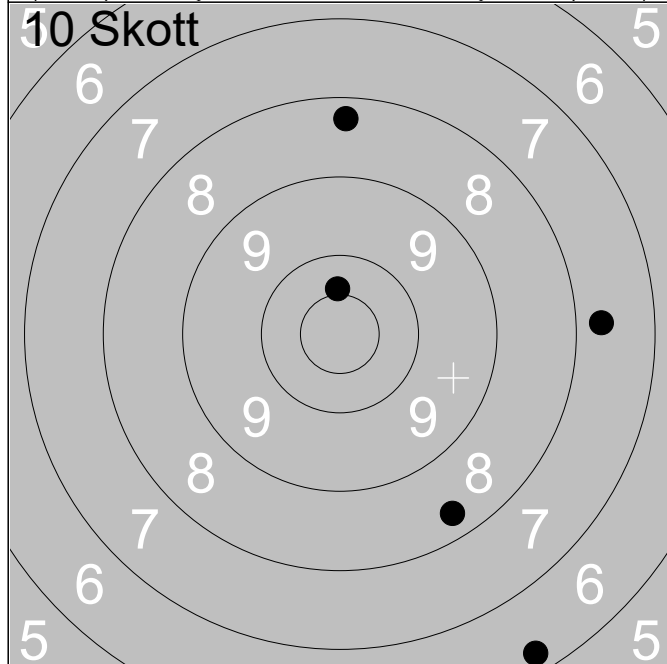

	1:	8.3	↑
	2:	10.4	↑
	3:	6.3	↓
	4:	8.3	↓
	5:	7.7	→
Serie			39.0
Total			256.0

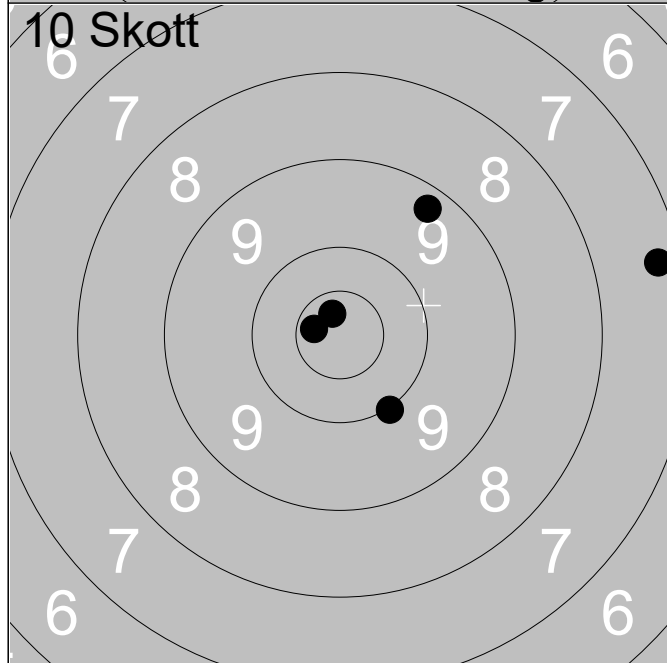

	6:	7.3	→
	7:	10.7x	←
	8:	10.0	↓
	9:	10.7x	↑
	10:	9.3	↗
Serie			46.0
Total			302.0

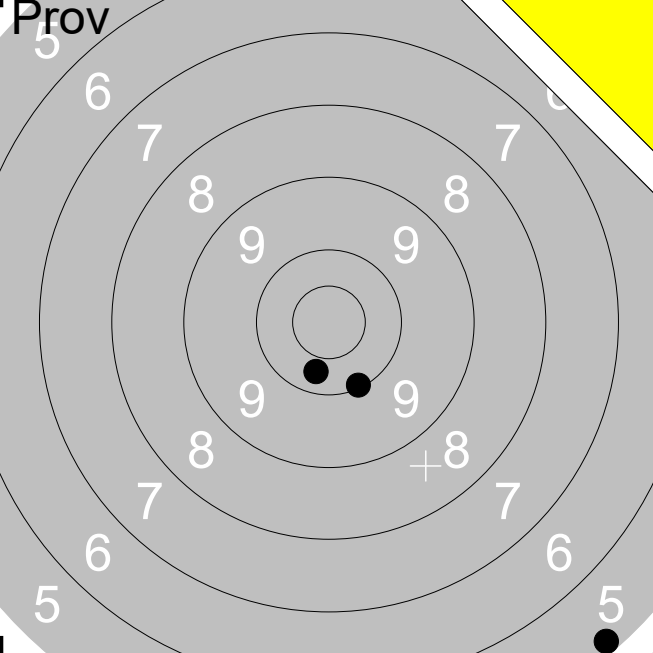
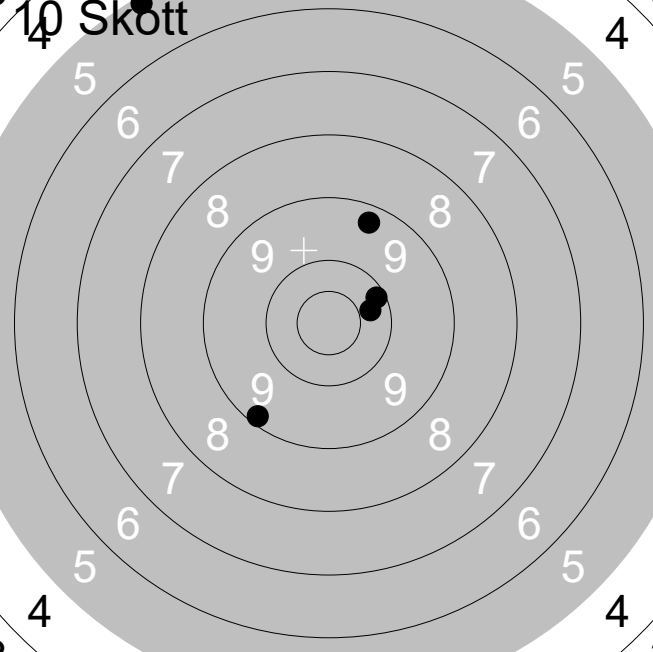
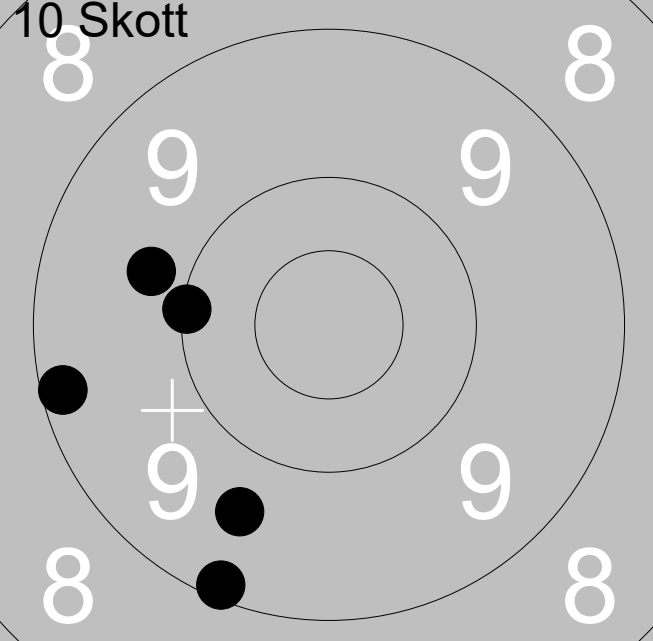
13.07.2023	Björkskottet 2023	Ramselefors SKF	
Prov 	1:	10.3	↓
	2:	10.1	↓
	3:	5.2	↓
	Serie		25.0
Total			210.0
10 Skott 	1:	9.2	↙
	2:	9.3	↑
	3:	5.1	↖
	4:	10.3	→
	5:	10.1	↗
	Serie		43.0
Total			253.0
10 Skott 	6:	9.8	↖
	7:	9.2	↖
	8:	9.6	↓
	9:	10.1	↖
	10:	9.1	↓
	Serie		46.0
Total			299.0

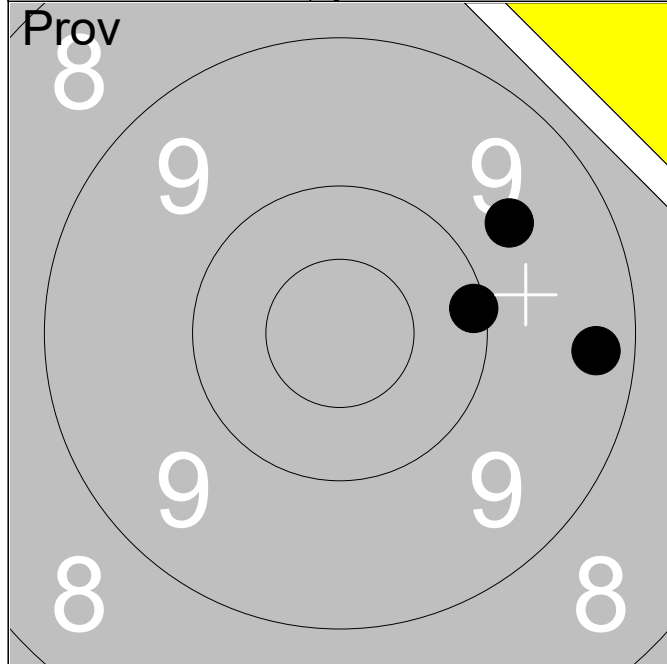

1:	9.3	→
2:	9.7	↗
3:	10.1	→
Serie		28.0
Total		207.0

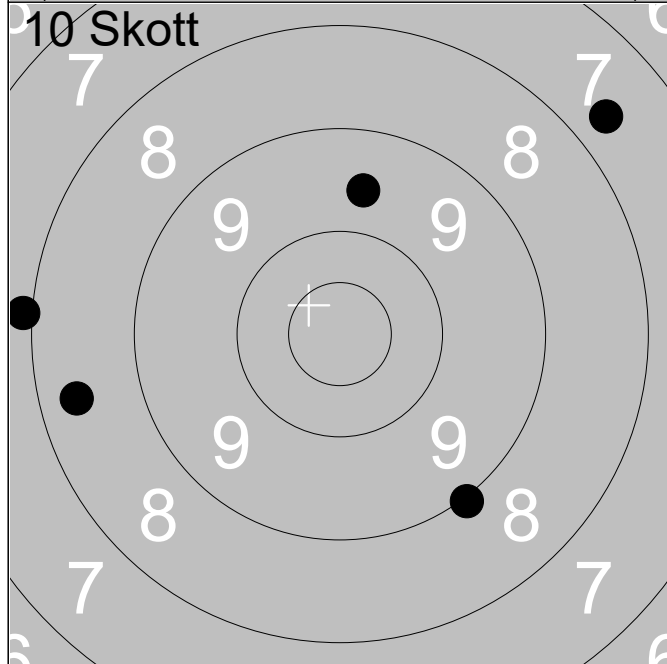

1:	7.7	↗
2:	9.0	↘
3:	8.4	←
4:	7.9	←
5:	9.6	↑
Serie		40.0
Total		247.0

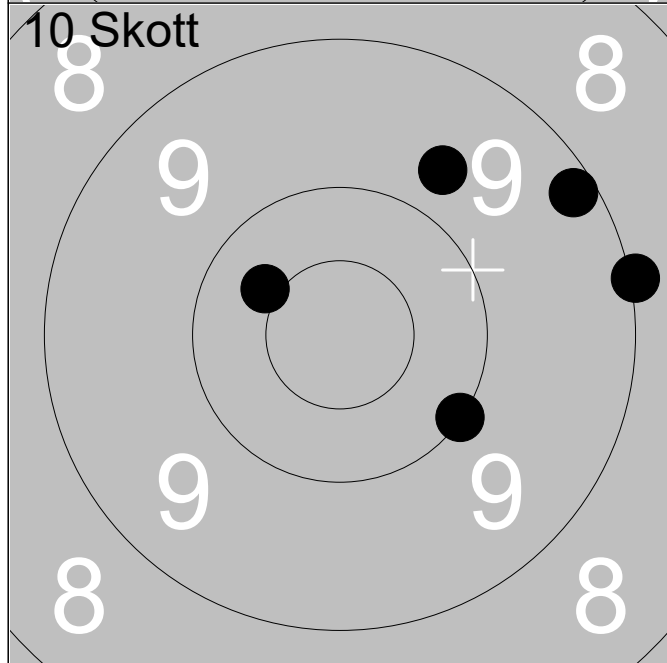

6:	10.4	↖
7:	9.2	↗
8:	9.7	↗
9:	10.0	↘
10:	9.0	→
Serie		47.0
Total		294.0

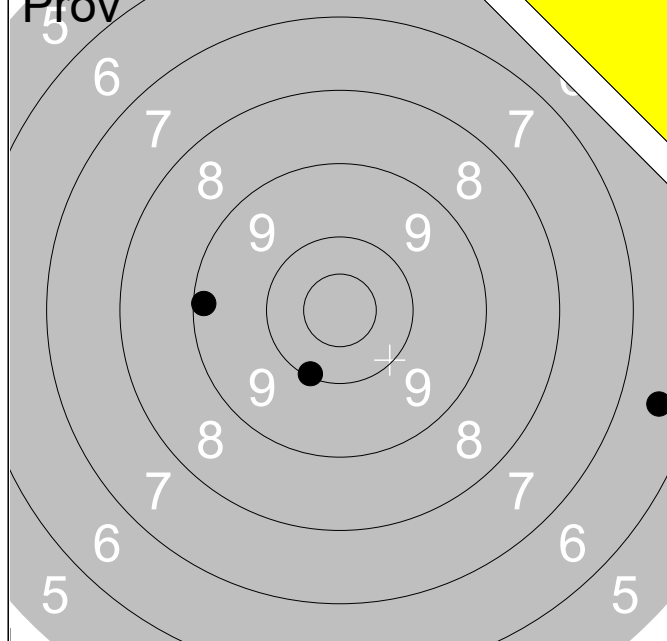

1:	9.2	←
2:	10.1	↓
3:	6.5	→
Serie		25.0
Total		207.0

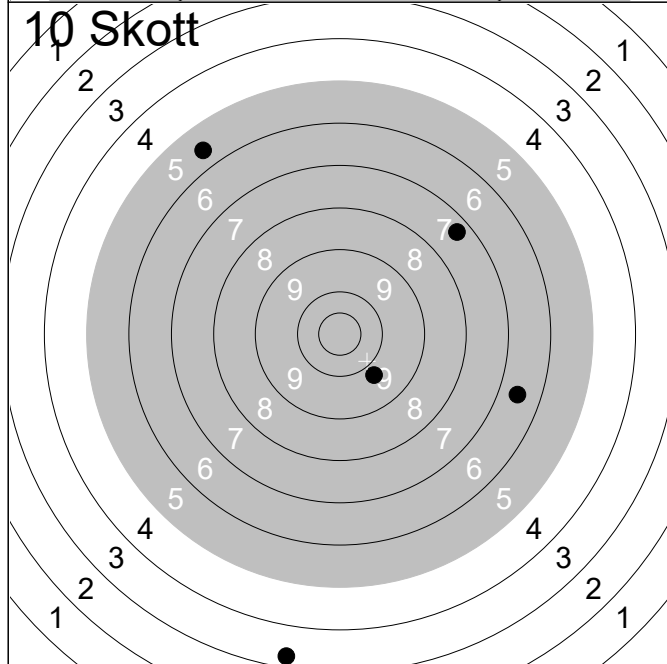

1:	3.3	↓
2:	5.6	↗
3:	9.8	↓
4:	7.4	↗
5:	6.6	→
Serie		30.0
Total		237.0

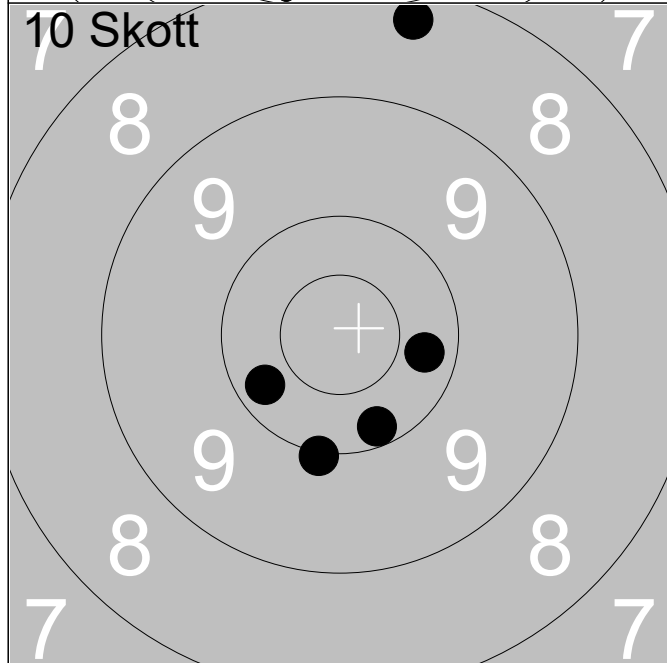

6:	8.3	↑
7:	10.2	←
8:	10.0	↓
9:	10.2	↓
10:	10.3	→
Serie		48.0
Total		285.0

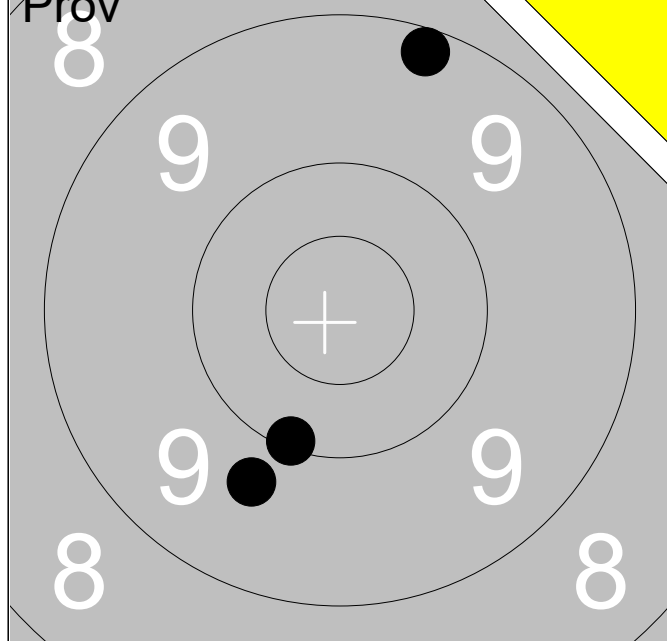

1:	9.2	↗
2:	10.1	↘
3:	9.7	↘
Serie		28.0
Total		207.0

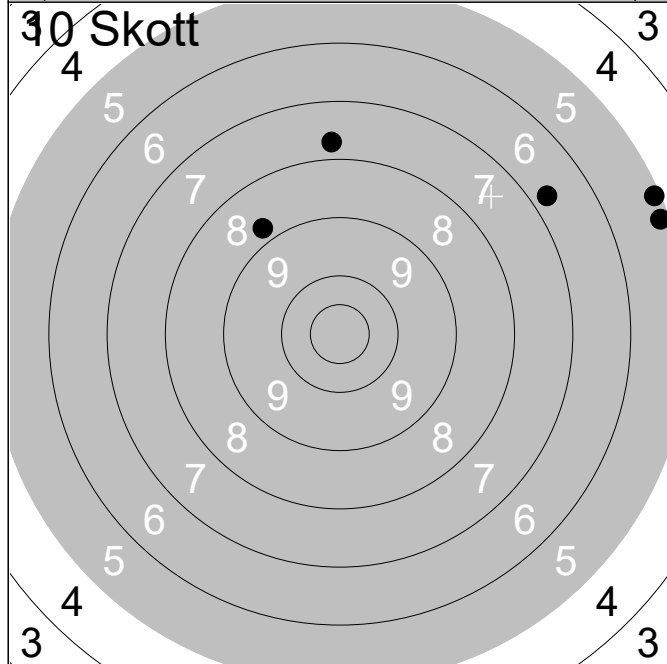

1:	5.1	↗
2:	5.2	↗
3:	6.8	↗
4:	8.8	↖
5:	7.7	↗
Serie		31.0
Total		238.0

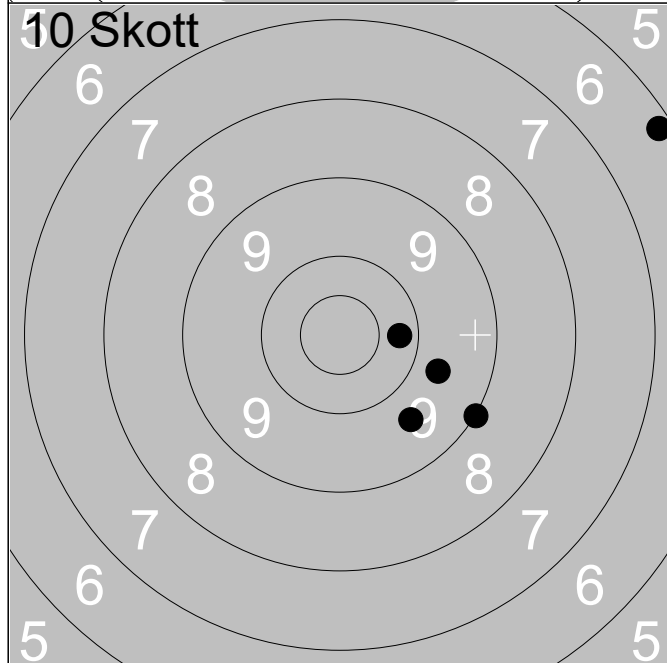

6:	6.2	↗
7:	10.2	→
8:	9.6	↘
9:	9.7	→
10:	9.0	↘
Serie		43.0
Total		281.0

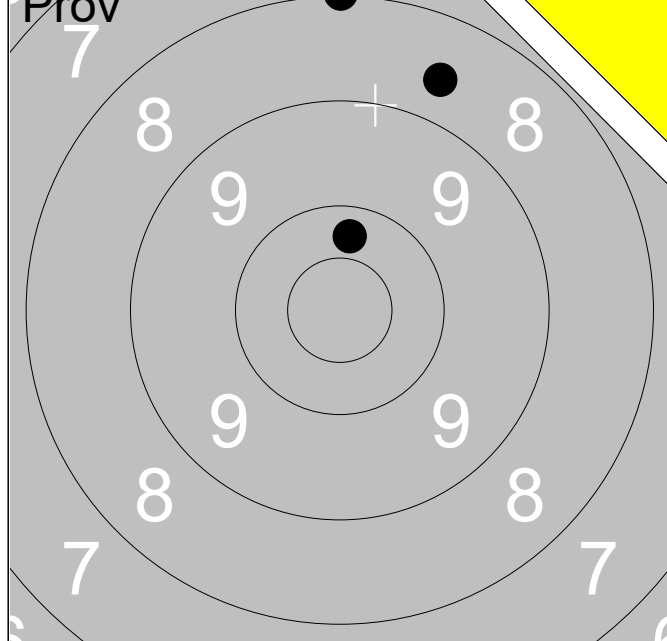

1:	8.6	↗
2:	10.3	↑
3:	8.0	↑
Serie		26.0
Total		205.0

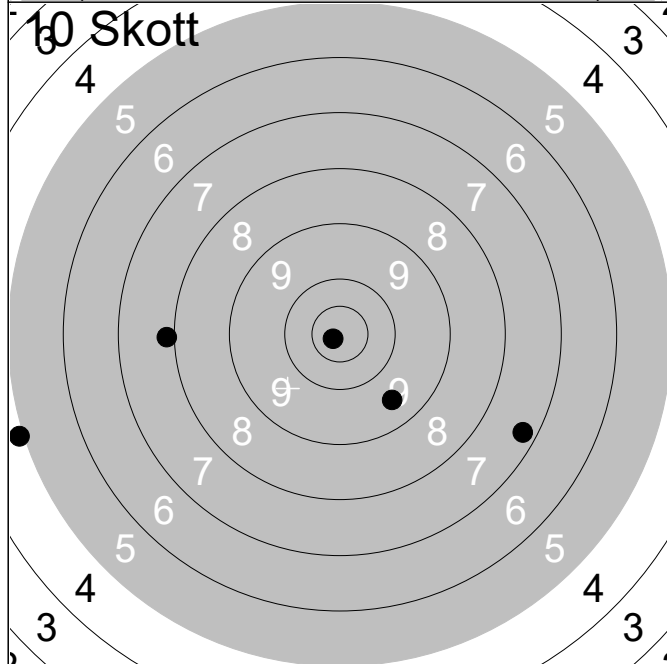

1:	7.3	↘
2:	4.9	←
3:	7.9	←
4:	9.5	↘
5:	10.8x	↙
Serie		37.0
Total		242.0

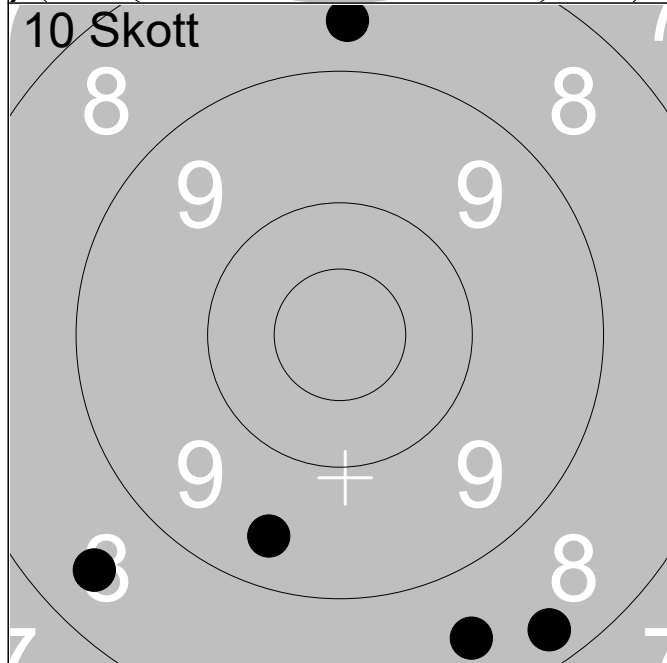

6:	8.5	↙
7:	8.3	↘
8:	8.5	↘
9:	8.6	↑
10:	9.4	↘
Serie		41.0
Total		283.0

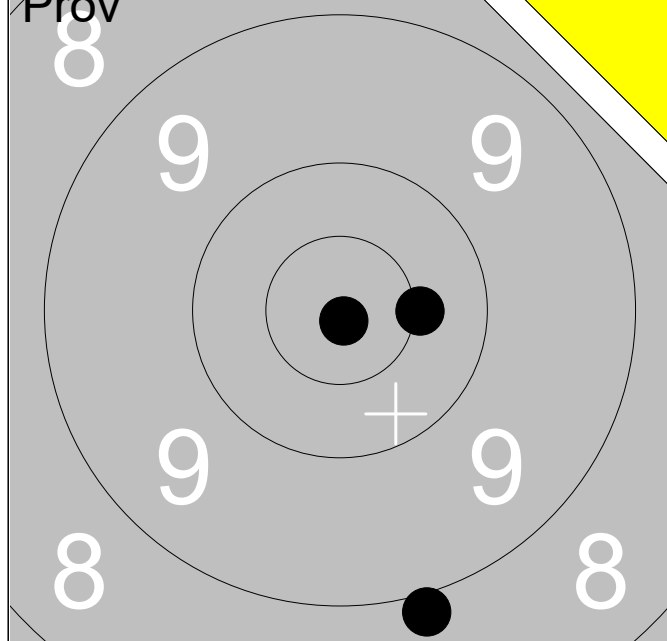

1:	10.9x	↓
2:	10.4x	→
3:	8.9	↓
Serie		28.0
Total		203.0

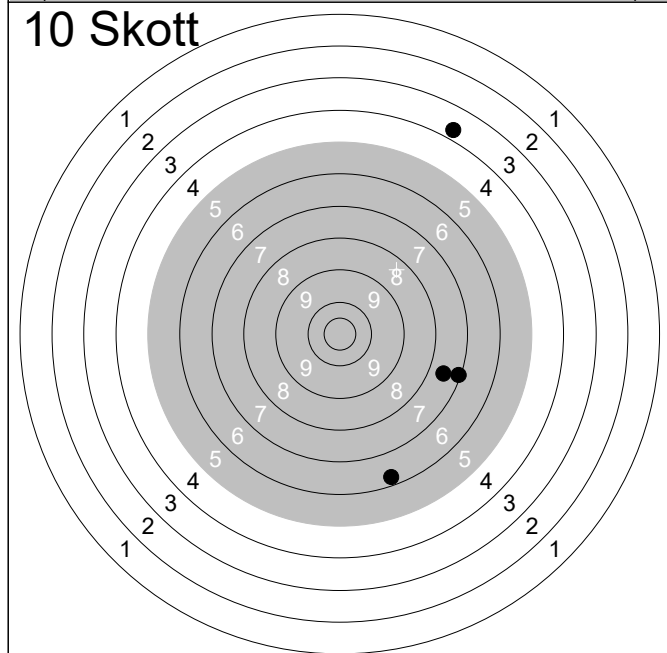

1:	6.3	↓
2:	0.0	↑
3:	3.7	↗
4:	7.1	→
5:	7.6	↘
Serie		23.0
Total		226.0

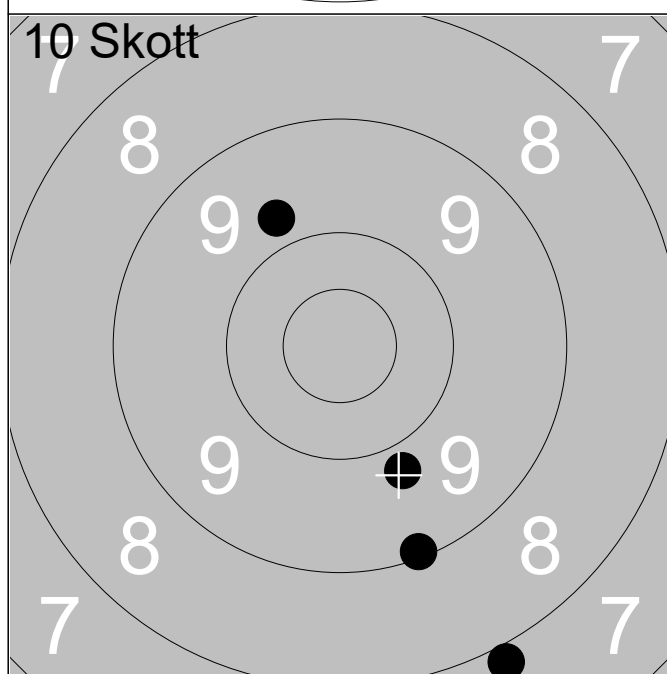

6:	7.9	↓
7:	9.8	↗
8:	9.1	↓
9:	9.8	↓
Serie		34.0
Total		260.0

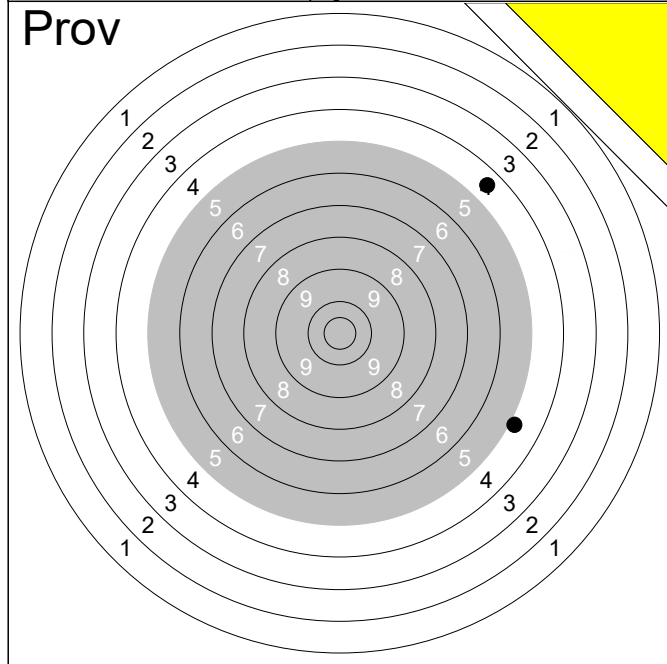

1:	4.9	→
2:	0.0	↗
3:	4.5	↗
<hr/>		
Serie		8.0
Total		192.0

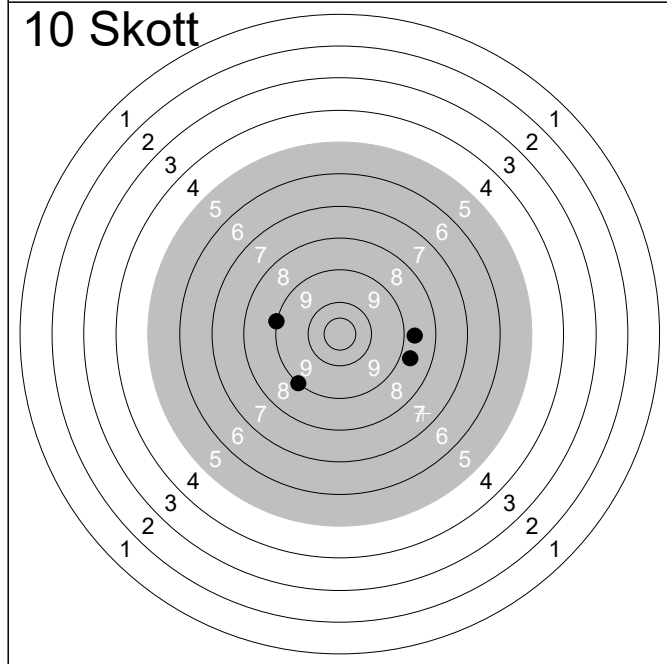

1:	8.7	→
2:	8.7	→
3:	0.0	↘
4:	9.0	←
5:	9.0	↙
<hr/>		
Serie		34.0
Total		226.0

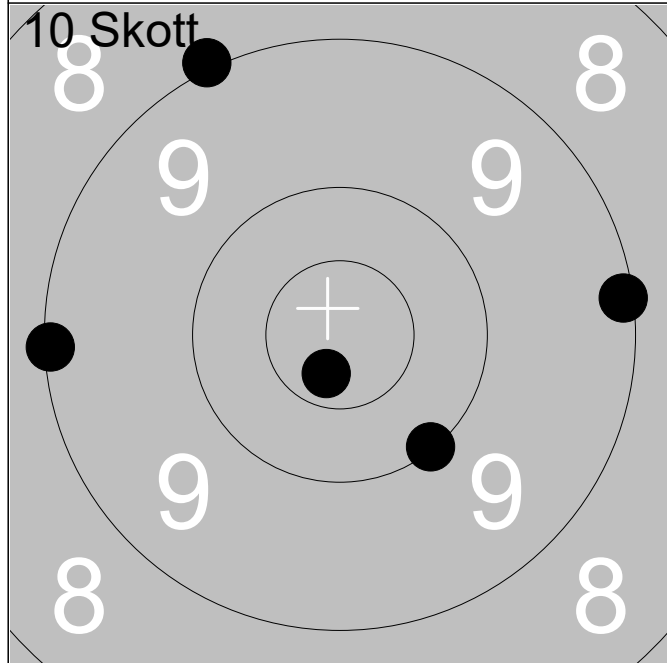

6:	9.1	←
7:	10.7x	↘
8:	10.0	↘
9:	9.0	↗
10:	9.1	→
<hr/>		
Serie		47.0
Total		273.0